



AALBORG UNIVERSITY
DENMARK

Aalborg Universitet

Architectural Quality of Low Energy Houses

Lauring, Michael; Marsh, Rob

Published in:
Passivhus Norden 2008 Conference Proceedings

Publication date:
2008

Document Version
Publisher's PDF, also known as Version of record

[Link to publication from Aalborg University](#)

Citation for published version (APA):
Lauring, M., & Marsh, R. (2008). Architectural Quality of Low Energy Houses. In *Passivhus Norden 2008 Conference Proceedings: Den første nordiske passivhuskonferanse* (pp. 126-133). SINTEF.

General rights

Copyright and moral rights for the publications made accessible in the public portal are retained by the authors and/or other copyright owners and it is a condition of accessing publications that users recognise and abide by the legal requirements associated with these rights.

- Users may download and print one copy of any publication from the public portal for the purpose of private study or research.
- You may not further distribute the material or use it for any profit-making activity or commercial gain
- You may freely distribute the URL identifying the publication in the public portal -

Take down policy

If you believe that this document breaches copyright please contact us at vbn@aub.aau.dk providing details, and we will remove access to the work immediately and investigate your claim.

1st Nordic passive house conference Passivhus Norden 2008

April 2 and 3 in Trondheim, Norway

This is the first conference in a Nordic series of seminars on passive houses.

Themes for the conference is passive houses and: zero emission, energy scenarios, architecture, solar- and bio energy, standardization, certification, technology, components, economy, occupant focus, indoor climate, exemplary projects, marketing, innovation.

SCIENTIFIC COMMITTEE

Inger Andresen, SINTEF Buildings and Infrastructure (NO)
Tor Helge Dokka, SINTEF Buildings and Infrastructure (NO)
Michael Klinski, the Norwegian State Housing Bank (NO)
Anne Grete Hestnes, the Norwegian University of Science and Technology (NO)
Per Heiselberg, University of Aalborg (DK)
Søren Pedersen, Passivhus.dk (DK)
Rikka Holopainen, VTT (FI)
Timo Kalema, Tampere University (FI)
Maria Wall, Lund University (SE)
Hans Eek, Passivhuscentrum (SE)
Ivana Kildsgaard, IVL Swedish Environmental Research Institute (SE)
Åsa Wahlstrøm, SP Technical Research Institute of Sweden (SE)

ORGANIZING COMMITTEE

Anne Gunnarshaug Lien, Enova
Anne Guri Selnæs, Enova
Are Rødsjø, the Norwegian State Housing Bank
Helene Slagstad, the Norwegian State Housing Bank
Lene Frosthammer, the Norwegian State Housing Bank
Inger Andresen, SINTEF Buildings and Infrastructure
Tor Helge Dokka, SINTEF Buildings and Infrastructure
Anne Grete Hestnes, the Norwegian University of Science and Technology

www.passivhusnorden.com

Passivhus Norden 2008, April 2

SESSION 1: *Experiences from passive house projects*

Chair: Professor Maria Wall, Lund University

13:00 Torben Thyregod Jensen, Pia Thomsen

SOLTAG, a development project focusing on: Energy, Architecture, Daylight & Indoor Climate8

13:30 Ulla Janson

Experiences from three Swedish passive house projects.....15

14:00 Peder Vejsig Pedersen,

The first experiences in Denmark with passive house design and use of architecturally optimised solar roofs.....22

14:30 Riikka Holopainen, Juhani Laine, Mikko Saari, Mika Airaksela, Tuomi Jouni

MERA Multi-storey Building - Finnish Passive House28

SESSION 2: *Passive house components and solutions*

Chair: Professor Per Heiselberg, Aalborg University

13:00 Jørn Stene

CO2 Heat Pump System for Space Heating and Hot Water Heating in Low-Energy Houses and Passive Houses36

13:30 Henrik Davidsson, Bengt Perers, Björn Karlsson

Performance of a multifunctional PV/T hybrid solar window.....44

14:00 Tor Helge Dokka, Leif Amdahl

Forenklet og kostnadseffektiv vannbåren varme skreddersydd til passivhus-leiligheter.....52

14:30 Jørn Stene, Tore Hjerkin.

High-Efficiency Heat Pump Water Heater System for Apartment Buildings of Passive House Standard.....57

SESSION 3: *Scenarios and feasibility studies*

Chair: Senior Architect Michael Klinski, Husbanken

13:00 Timo Kalema, Petri Pylsy

Low-energy house concepts for Nordic countries.....66

13:30 Marit Thyholt, Tore Wigenstad

Fjernvarmens rolle i fremtidens energieffektive boliger.74

14:00 David N. Benjamin

The renovation of existing buildings to passive house standards: A literature review81

14:30 Bjørn Jenssen Wachenfeldt, Igor Sartori

Midt-Norge som pilotregion for passivhus satsing: Potensialstudie82

SESSION 4: Experiences from design and construction of passive houses

Chair: Riikka Holopainen, VTT Technical Research Centre Finland

15:30 Olav Langenkamp The first certified passive house in Denmark	94
15:50 Maria Wall, Ulla Janson Apartment buildings as passive houses in Värnamo, Sweden	97
16:15 Bengt Michalsen, Georg Orvedal Planlegging og bygging av passivhus i Lierbyen, Lier Kommune	103
16:40 Michael Klinski; Lars K. Halleraker, Harald Ringstad Det første sertifiserte passivhus i Norge	111
17:05 Petra Vladykova, Carsten Rode, Toke Rammer Nielsen, Søren Pedersen Passive Houses for Arctic Climates	118

SESSION 5: Planning and architecture

Chair: Architect Stein Stoknes

15:30 Michael Luring, Rob Marsh Architectural quality of low energy houses	126
15:50 Anne Kirkegaard Bejder, Poul Henning Kirkegaard, Henrik Brohus, Anna Marie Fisker MCDM in practice – an architectural point of view	134
16:10 Søren Riis Dietz, Mette Maren Maltha "Omgivelsernes indflydelse på design af passivhuse – hvordan optimeres design strategien, så også strukturplaner og bebyggelsesplaner fremtidssikres?"	144
16:40 Olav Langenkamp Igangværende passivhusprojekter, Aarhus Arkitekterne	150
17:05 Knut Selberg Passivhus, layout og iboende egenskaper for energiøkonomisering	151

SESSION 6: Environmental analysis and user perspective

Chair: Ivana Kildsgaard, IVL Swedish Environmental Research Institute

15:30 Anna Joelsson, Leif Gustavsson The need for a life cycle perspective on the passive house concept	162
15:50 Charlotta Isaksson Learning to Live in a Passive House	169
15:10 Kristina Mjörnell, Jesper Arfvidsson, Svein Ruud, Pernilla Johansson, Joakim Norén, Lars-Erik Harderup, Anna Jarnehammar Framtidens trähus – Energieffektiva med god innemiljö. Future Timber Framed Houses - Energy Efficient with Good Indoor Environment	171
16:40 Wiktoria Glad, Fredrik Karlsson, Kajsa Ellegård, Ewa Wäckelgård Sociotekniska studier av lågenergihus	176
17:05 Leif Gustavsson, Anna Joelsson Multi-storey wood buildings in a life cycle perspective	184

Passivhus Norden 2008, April 3

SESSION 7: Workshop on *Market and strategy*

Chair: Dr.ing. Anne G. Lien, Enova and Architect Are Rødsjø, Husbanken

10:30 Erwin Mlecnik

Marketing of Passive Houses: Experiences from the Low Countries194

10:45 Kersten Bonnén

Markedskommunikationsstrategier for lavenergihuse: Skal man tale til forbrugernes hjerte eller hjerne?204

11:00 Ann Kristin Kvelheim, Enova

Enova's market strategy for passive houses

11:15 Eva Ekrem, Bård Haugen, Åslaug Hennissen

Hvordan selge passivhus211

11:30 Trond Haavik, Synnøve Aabrekk, Edward Prendergast

Hvordan markedsføre energieffektive boliger?213

11:45 Discussion

SESSION 8: Workshop on *Training and education*

Chair: Professor Anne Grete Hestnes, NTNU

10:30 Magnar Berge

Klimahuset ved Høgskolen i Bergen222

10:45 Magne Våge, Henrik Kofoed Nielsen, Bengt Michalsen

Planlegging og bygging av passivhus i Grimstad226

Short presentations from University of Aalborg, University of Lund, University of Tampere and Norwegian University of Science and Technology234

11:00 Maria Wall

Education at Lund University

11:15 Per Heiselberg

Education at Aalborg University

11:30 Timo Kalema

Education at Tampere University

11:45 Anne Grete Hestnes

Education at NTNU

12:00 Discussion

SESSION 9: Workshop on Standardization and certification

Chair, Dr. Berthold Kaufmann, Passivehaus Institute

10:30 Susanne Dyrbøl, Kirsten Engelund Thomsen, Kim B. Wittchen

Member State approach towards a strategy for passive/very low-energy Buildings236

10:45 Jyri Nieminen, Riikka Holopainen, Kimmo Lylykangas

Concepts and market acceptance of a cold climate Passive House242

11:00 Inger Andresen and Tor Helge Dokka, Thor Endre Lexow

New Norwegian Standard for Low Energy and Passive Houses250

11:45 Åsa Wahlström, Svein Ruud, Martin Erlandsson, Jonas Norrman, Eje Sandberg, Maria Wall, Hans Eek

A Classification of Passive House for Swedish Conditions256

12:00 Søren Pedersen, Passivhus.dk

Certification in Denmark..260

SESSION 10: Planning and design of passive house projects

Chair: Søren Pedersen, Passivhus.dk

14:00 Svein H. Ruud, Kristina Mjörnell, Åsa Wahlström

SQUARE –A Quality Assurance MANAGEMENT system FOR retrofitting with good indoor ENVIRONMENT and energy efficiency.....262

14:30 Robert Nøsen, Erling Bakkemo, Åslaug Hennissen

Fremtidens hus i dag269

15:00 Helena Bülow-Hübe

Analys av förutsättningar och begränsningar vid utformning av skolor, förskolor och äldreboenden som passivhus i Sverige.....272

15:30 Tor Helge Dokka, Kjetil Helland

Løvåshagen: Norges første lavblokkprosjekt med passivhusstandard283

SESSION 11: Planning and design of passive houses

Chair: Hans Eek, Passivhuscentrum.se

14:00 Charlotte Højmark, Flemming Hoff Jakobsen

KomfortHusene, 10 different single family houses under construction.....292

14:30 Odd Karl Steinsvik

I-Box 120 – Norges første passivhus300

15:00 Igor Sartori, Bjørn J. Wachsfeldt

Case study on retrofit of a Norwegian school: possible to achieve the passive house standard?301

15:30 David Benjamin

Experience with the design process for almost passive houses for low cost housing in the extreme cold climates of North America: Lessons for Scandinavia?.....309

SESSION 12: *Passive house components and solutions*

Chair: Jørn Stene, SINTEF Energy Research

14:00 Bengt Hellström	
Impact of window properties on the heating demand of a passive house	312
14:30 Hans Martin Mathisen, Monica Berner, Johan Halvarsson, Sten Olaf Hanssen	
Behovsstyrt ventilasjon av passivhus – Forskriftskrav og brukerbehov	320
15:00 Matthias Haase, Inger Andresen, Berit Time, Tore Kvande, Anne Grete Hestnes	
Energy-efficient office buildings in Norway – from low energy standard to passive house standard	328
15:30 Inger Andresen, Klaus Ellehauge, Björn Karlsson, Jyri Nieminen	
Solar heating systems for passive houses in the Nordic countries – An Overview	336

Session 1

Experiences from passive house projects

Torben Thyregod Jensen, Pia Thomsen

SOLTAG, a development project focusing on: Energy, Architecture,
Daylight & Indoor Climate. 8

Ulla Janson

Experiences from three Swedish passive house projects..... 15

Peder Vejsig Pedersen,

The first experiences in Denmark with passive house design and use of
architecturally optimised solar roofs. 22

Riikka Holopainen, Juhani Laine, Mikko Saari, Mika Airaksela,

Tuomi Jouni

MERA Multi-storey Building - Finnish Passive House 28

SOLTAG, a development project focusing on: Energy, Architecture, Daylight & Indoor Climate.

Torben Thyregod Jensen,
VELUX A/S, Ådalsvej 99, 2970 Hørsholm – Phone: +45 4516 4784,
E-mail: torben.thyregod@velux.com

Pia Thomsen
VELUX A/S, Ådalsvej 99, 2970 Hørsholm – Phone: +45 4516 4763
E-mail: pia.thomsen@velux.com

1 Abstract

EU has published an Action Plan on Energy Efficiency [COM (2006) 545] which contains information about how the Commission wants to develop a strategy for low energy and passive houses. The EU Commission's most recent environmental initiative has been to develop directives to limit CO₂ emissions from buildings and to secure supply of energy for future citizens.

The EPBD [Directive 2002/91/EC] describes the frameworks for energy consumption in the buildings. The frameworks are to be implemented in national legislation and new standards that will serve to achieve significant energy savings in buildings.

In several European countries the directive has contributed to energy savings of 25-30% in relation to former requirements for new buildings. Further energy savings are expected in 2010 and again in 2015. This will result in a major reduction in energy consumption in new buildings over 10 years. The new rules will also influence the building components market and the use of renewable energy.

The energy crises in the 1970'ies caused wish of saving energy in the building stock; and a lot of new buildings were constructed with very small window areas and thick walls. VELUX wishes to clarify that it is possible to build energy efficient with focus on daylight, fresh air and quality of life for the people living in the buildings.

SOLTAG answers the call for zero-energy, CO₂-neutral housing of the future. By use of thermal solar energy and upgrading the use of solar cells, we can achieve an energy consumption of 0 kWh/m² for heating.



2 Introduction

Based on the climate changes and the security of energy supply, EU and others have initiated a number of programmes, which are going to demonstrate physically the building of posterity and uncover the possibilities for this sector. Under the 6. frame work programme a project DemoHouse was founded, having the target to demonstrate the renovation on the existing buildings in 9 European countries. In this context VELUX will participate actively in the creation of future attic dwellings with focus on energy, architecture, living comfort and environment.

Together with the other partners: Nielsen and Rubow, CENERGIA and Kuben Byfornyelse, VELUX made a demonstration project on CO₂ neutral housing that has formed a part of the demo house programme.

SOLTAG is based on the latest know-how in sustainable construction. The architecture exploits the best energy-optimising building components and incorporates the prefabricated elements so that the construction technology is correctly applied and the elements speak the same design language. The various building components, each with its own energy function, are used to strengthen and contribute to a holistic solution featuring a healthy indoor climate in contemporary energy-balanced architecture built to respond to people.

3 Method

Energy need for heating.

The window area of SOLTAG is 28% of the floor area, almost double that of standard window areas. The north-facing windows are super low-energy windows with a U_w -value of 1.0-1.2 W/m²K, while the south-facing windows are standard windows with a U_w -value of 1.5 W/m²K and which, in addition to providing good daylight illumination also allow solar heat to pass through the window.

Room heating	30 kWh/m ²
Hot water	15 kWh/m ²
Cooling <small>(6 kWh/m², in DK converted to primary energy by a factor of 2.5)</small>	15 kWh/m ²
Total energy need <small>(Ventilation summer: 0.9l/s/m²(air change), no sun screening)</small>	60 kWh/m²

By using this passive solar heat during the heating season, the need for heating is reduced.

Figure 1: Energy demand for SOLTAG

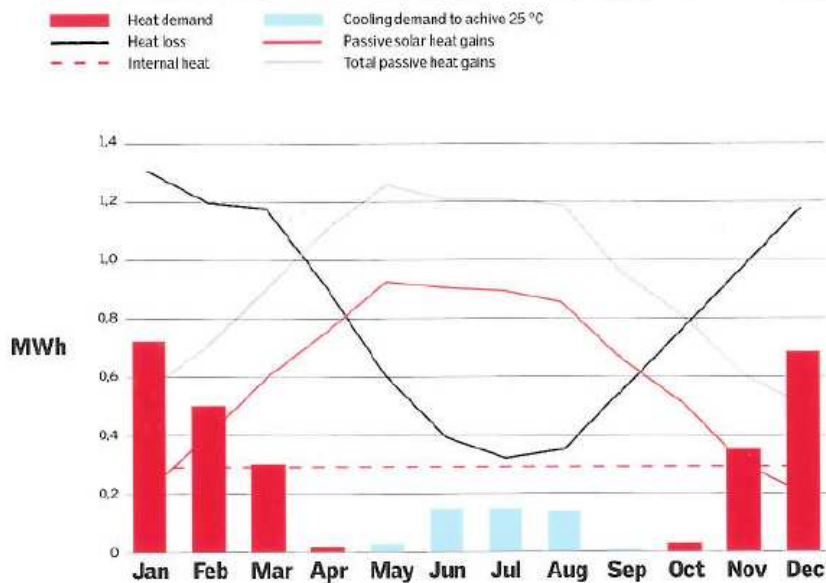

This figure shows how the passive solar heating through the windows contributes to reducing the need for heating. For example, if the passive solar heating delivers 0.6 MWh in March and internal heat delivers 0.3 MWh, it means that the need for supplementary heating is only 0.3 MWh.

The energy requirements of the building have been minimized through low energy constructions and strategically design of the house. The energy that is needed for the house is collected from the roof surface either through solar panels, PV or preheated air for the air heat pump.

Energy need for hot water.

SOLTAG is designed as a home for 2 people, so the energy need for hot water constitutes app. 1500 kWh, equivalent to 15 kWh/m².

Energy need for ventilation, heat pump etc.

The energy need for ventilation, heat pump etc. depends on which ventilation and solar shading strategy is chosen for the home during the summer months. As a starting point, summer ventilation of 0.9 l/s/m² has been chosen, which means that during the summer there will be periods when the indoor temperature exceeds 25°C resulting in a need for cooling. This need for cooling can be met in several ways. If mechanical cooling is chosen, the need is 6 kWh/m². As mechanical cooling is created through using the electrical power, consumption must be corrected, resulting in a consumption of 15kWh/m².

It is possible to avoid using energy for cooling by ensuring that the indoor temperature does not exceed 25°C. In northern climates mechanical cooling can be avoided by means of natural ventilation and/or solar shading.

If a ventilation flow of 1.6 l/s/m² is provided, corresponding to the air being changed approx. 1.9 times per hour, the need for mechanical ventilation can be avoided. Energy consumption for mechanical cooling is 0 kWh/m².

Another method of reducing the indoor temperature is to establish external sun screening, which is activated according to need, i.e. when the sun shines and the indoor temperatures are high. Simply by using the sun screening on south-facing windows, the need for cooling is reduced to 1.6 kWh/m². By increasing the ventilation flow slightly, this can be reduced further to 0 kWh/m².

Heating System

The heating system used in SOLTAG is underfloor heating, which uses heat from solar panels and an air heat pump. The air for the heat pump circulates from the base to the ridge of the roof where it is pre-heated before being fed into the pump; here, the heat in the air is used to heat the water for the underfloor heating.

Principle

The principle behind SOLTAG is that during the year solar energy is collected via the solar panels (thermal) and solar cells (PV), which are installed on the roofing panels. The energy, which is collected as electricity, is transmitted to the electricity grid, from where it is drawn as and when required, primarily in the winter months. The energy consumption for hot water is largely covered by thermal solar energy panels of 2m², that produce domestic hot water and under-floor heating.

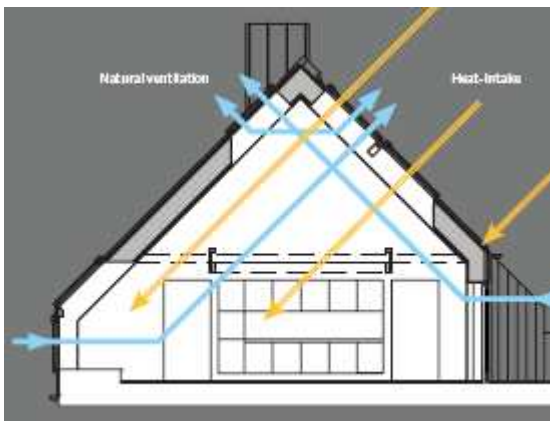

The energy system is well designed and integrated.

The 3.5 m² solar cell panel on the SOLTAG unit roof generates the electricity to run the pumps and ventilators. A compact, built-in heat-recovery ventilation unit and a mechanical ventilator transfer the heat from the spent, heated air to now fresh air taken from outside; 90% of the heat is recycled. A solid climate screen, with strategically placed low energy windows, 350 mm of insulation in the walls and 400 mm in the roof and an airtight construction with no cold bridges, keeps the heat in.

An extra 14 m² of solar cells panels can generate enough electricity to meet the needs of the pumps and ventilators for the entire winter energy.

The prefabricated demo apartment has been erected at VELUX A/S, Hørsholm DK, but was first used for public demonstration purposes until end March 2006. We think that seeing is believing and with the demo apartment, it is possible to measure the energy used and experience the living comfort of the building.

The house is still open for visits by delegations.

4 Results

SOLTAG has its own life and generates nourishment for the residents' comfort. The 45° saddle roof faces south, so the thermal solar panels and solar cells on the large roof area are put to full use.

The roof reaches skywards while protecting its living space below. The home naturally integrates its many energy mechanisms. SOLTAG has many sluices and energy aggregates for air and electricity intake, but this circulation is so unobtrusive that there is room for people. The pumps and ventilation system are at the heart of the house, assembled in a closed core area at the centre of the house. The air ducts are hidden under the roof and the solar cells and panels are incorporated in the roofing panels. People are in focus and the home creates the setting for a good life.

The home is constructed from modules designed and fitted out as prefabricated kits. The modules are installed quickly, which minimises the nuisance factor for residents in the buildings where SOLTAG is built on. The

modules can be connected to existing building or constructed for new buildings. The modules are custom-made and adapted for each different project, with consideration the building context and financial resources.



SOLTAG's prefabricated modules are manufactured under optimum conditions in the production hall then transported to the building site.

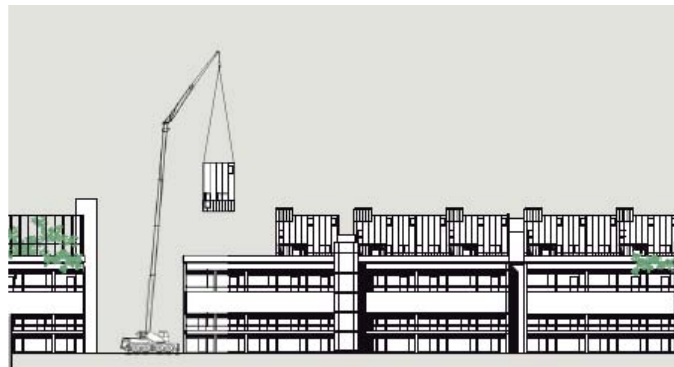

Modules for SOLTAG are joined to form a housing unit.

The attic dwelling can be the most interesting place in the house with evenly distributed light and contact with the sky. The basic dwelling is a two-room apartment of 84 m². The home comprises two basic modules that fit together. One module contains the main installations and kitchen, bathroom, hall and bedroom. The other module consists of dining and living area with an open loft-style area. The north-facing frontage has an external gallery, which provides the most flexible access. To the south, it has a cantilevered balcony that fully exploits the depth of the house.



Floor Plan: An 84 m² SOLTAG housing unit.

The home is build by using the six steps to reduce energy consumption formula:

1. Prefabricated constructions without cold bridges and with good air tightness.
2. Use of heat recovery ventilation (HRV) with low electricity use.
3. Low energy windows towards the south to use passive heat radiation. Super low energy windows towards the north for maximum insulation.
4. Use of an adapted energy supply for heating and DHW. By use of a small air and solar roof based heat pump, a good energy quality is obtained and at the same time separate energy supply is avoided.
5. Use of a solar heated domestic hot water (DHW) system to obtain 50% reduction of the energy for DHW.
6. Use of photovoltaic (PV) modules to reach a desired or even a climate-neutral low-energy level.

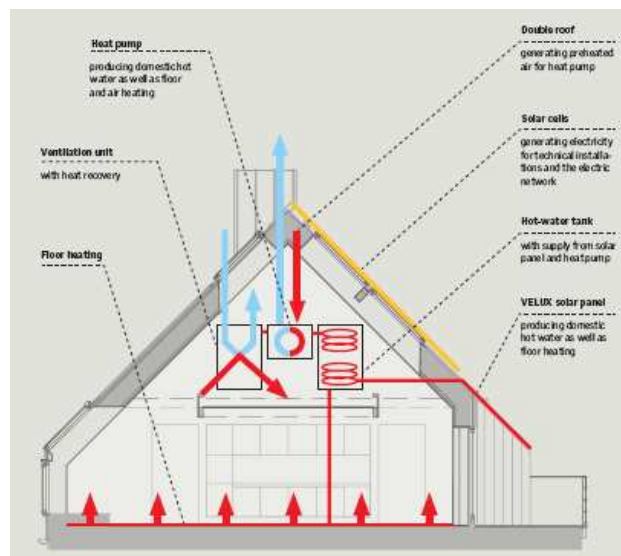

SOLTAG is devised as a home that runs itself and is independent of external heating systems.

5 Conclusions

Through the project it has been demonstrated that we can meet the future demand of CO₂ neutral housing like the ones in UK by 2016 and other countries also intend to follow.

It is possible to build a low energy house with lots of daylight, natural ventilation, of high quality, good architecture and with low energy consumption.

SOLTAG demonstrates the trends and sense in creating multi-disciplinary development. If we consider all the aspects of a building, there will be no diverging overlaps. Building functions will supplement each other and produce new combinations of high intelligence, sheer strength and quality by harnessing the sun, light and air.

SOLTAG rethinks building design as prefabricated building elements that integrate various disciplines and can be linked to or incorporated into modern architecture.



6 References

[COM (2006) 545]

COM (2006) 545 final. Action Plan for Energy Efficiency: Realising the Potential.

[Directive 2002/91/EC]

EPBD Directive 2002/91/EC of the European Parliament and of the Council on the energy performance of buildings.

[www.soltag.net]

The official SOLTAG website

[SOLTAG [Energy Housing]]

SOLTAG [Energy Housing], VELUX 2006

[Energy Facts]

Energy Facts, VELUX 2007

Experiences from three Swedish passive house projects.

Ulla Janson

Avd. För Energi och ByggnadsDesign, Box 118 221 00 Lund Sverige,

tel: 0046 46 222 7347, fax: 0046 46 222 4719, e-post: ulla.janson@ebd.lth.se

Introduction

The energy needed for heating buildings needs to decrease dramatically. Passive houses are a good solution for decreasing the need of energy for heating and at the same time keep a high indoor comfort. As a part of a research project funded by the Swedish Energy Agency, three new passive house projects have been built in Sweden. The main purpose with the research is to see what knowledge and components that are needed to build passive houses in Sweden. A good way of doing this is to follow actual building projects. These three demonstration projects have been followed from the beginning of the project with discussions with the client, through the planning and building process. After the tenants have moved in the buildings will be evaluated regarding actual energy consumption and comfort among the tenants. Support has been given when it has been needed for example with simulations of energy demand, purchasing of components and education. Experiences and ideas have been given continuously from all participants in the project. Everyone, from consultants to carpenters, has been given their experiences.

Värnamo, Oxtorget

The first demonstration project was finished in the summer 2006. In Värnamo 40 rental apartments were built as a part of the public housing sector, see Figure 1.



Figure 1: Apartment building in Värnamo, Oxtorget

The apartments are in five buildings in two or two and a half storeys. The apartments are heated by air and each apartment has its own air-to-air heat exchanger. Solar panels on all five buildings contribute to the supply of domestic hot water. Additional heat for the heating battery in the air unit and for domestic hot water is supplied by electricity. The load bearing structure is made of concrete cast on site. The outer wooden walls and wooden roof construction is made at site.

The U-values of the construction in Oxtorget is presented in Table 1. At the time of purchasing, it was difficult to find windows and outer doors with low U-values on the Swedish market. Therefore the U-values of the windows are somewhat higher than in the other passive house projects. To be able to achieve an outer door with the required U-value of $0.6 \text{ W/m}^2, \text{ K}$, the client designed and developed an outer door for this project and had it made at one of Sweden's largest door producers.

Table 1: U-values of the building envelope parts

Building envelope	U-value (W/m ² K)
Ground floor (excl. foundation)	0.09
Exterior walls	0.095
Roof	0.07
Windows, average	0.94
Door	0.60

The buildings have been simulated in DEROB-LTH to see the need of energy for heating. The model of the house is shown in Figure 2.

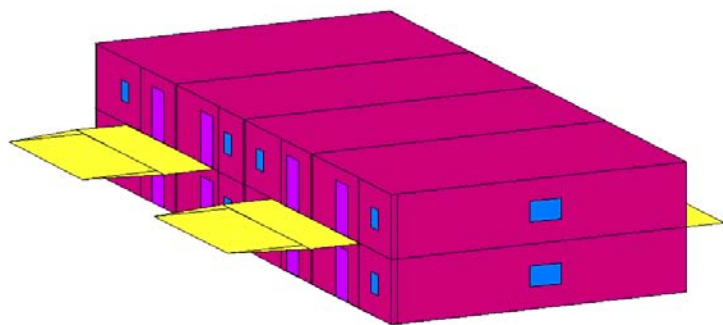

Figure 2: Building simulation in DEROB-LTH

With an indoor temperature of 20°C the peak load for space heating is calculated to 8.3 W/m². The space heating demand is then calculated to 9.8 kWh/m²a. If the indoor temperature is 22°C the peak load for space heating is calculated to 9.1 W/m² and the space heating demand is calculated to 12.8 kWh/m²a. The constructions are designed to avoid thermal bridges. Small thermal bridges might anyway occur in the junctions between parts of the construction. Energy demand caused by these thermal bridges is not included in the calculated result.

The tenants moved in to the apartments in the summer 2007. Measurements of actual energy consumption started at the same time as the tenants moved in. The average total bought energy (heating, domestic hot water, house hold electricity and electricity for common area) is measured to 67 kWh/m²,a. The energy used for heating is approximately 14 kWh/m², a, where most of the tenants tend to have a higher indoor temperature than 20°C.

One first questionnaire was sent out to the tenants during 2007 regarding indoor comfort. This questionnaire will be followed of interviews with the tenants during 2008.

Frillesås, Karl Johans väg

The passive house project in Frillesås contains of 12 rental apartments; see Figure 3, and is built as a part of the public housing sector.



Figure 3: Apartment building in Frillesås

The tenants moved in to the apartments in December 2006. The apartments are heated by air and each apartment has an air-to-air heat exchanger. Solar panels and district heating gives additional heat for the apartment and domestic hot water. The solar panels are placed on the roof of a separate building, see Figure 4.



Figure 4: Solar panels in Frillesås

The outer wooden walls, the roof and the load bearing construction is prefabricated and completed on site.

The U-values used in the constructions in the Frillesås project are shown in Table 2.

Table 2: U-values of the building envelope parts

Building envelope	U-value (W/m ² K)
Ground floor (excl. foundation)	0.11
Exterior walls	0.11
Roof	0.08
Windows, average	0.85
Entry door	1.0

It was not possible to buy the entry door used in the project in Värnamo. Instead, a glazed vestibule was built outside the entrance, to ensure low thermal losses, see Figure 5.



Figure 5: Glazed vestibules in Frillesås

The peak load for space heating and need for energy for heating was calculated in DEROB-LTH. With an indoor temperature of 20°C the peak load for space heating was calculated to 8.5 W/m² and the energy needed for space heating was calculated to 9.6 kWh/m²a. When simulating the building with an indoor temperature of 22°C, the peak load for space heating was calculated to 9.4 W/m² and the energy needed for space heating was calculated to 12.6 kWh/m²a. Additional energy demand caused by thermal bridges must be added to the calculated result. The simulations were based on placing the heating battery after the heat exchanger. Since the battery in reality was placed before the heat exchanger, the space heating demand and the peak load will be higher than the simulated values. Measurement of actual energy use started in February 2007 and has now just been finished. Evaluation of the measured results has just started.

Lidköping, Villa Malmborg

Villa Malmborg in Lidköping is the first one family house built as a passive house in Sweden. The house is in two storeys with a total living area of 170 m², see Figure 6.



Figure 6: Villa Malmborg

The house is heated by air and has an air-to-air heat exchanger. Additional heat for the air-heating battery and for domestic hot water is supplied by district heating. The house is made of wood and all parts are prefabricated.

Many different constructions were used in DEROB-LTH, to find the optimal solution with insulation thickness and window placements. The final construction had U-values as shown in Table 3.

Table 3: U-values used in the construction

Building envelope	U-value (W/m ² K)
Ground floor	0.10
Exterior walls	0.09
Roof	0.07
Windows, average	0.85
Entry door	1.0

If the indoor temperature was set in the simulations to 20°C the peak load for space heating was calculated to 9.2 W/m² and the energy needed for space heating was calculated to 15.2 kWh/m²a. When simulating the building with an indoor temperature of 22°C the peak load for space heating is calculated to 10.1 W/m² and the energy needed for space heating is calculated to 19.6 kWh/m²a. Additional energy demand caused by thermal bridges should be added to the calculated result. Measurement of actual energy use started in February 2008.

Experiences from the building process

Planning

When building passive houses it is important to work together, both in the planning group and in the building team. In the planning process it is important for the architect to keep a close dialogue with for instance the HVAC-consultant to ensure enough space for ducts, insulation and agree on a good placement of the ventilation unit. The construction of the building needs to be considered early in the planning process, to make sure that the construction is actually buildable. The architect and constructor here also need to have an on-going dialogue with the carpenter. Not thought through constructions will take long time to build on site and the original construction might be replaced by the carpenters to an easier construction that might not be the best solution for the project.

An educational visit early in the project has been seen as something very positive in all projects. To be able to see how a passive house works and that it is nothing special has made the carpenters more relaxed. It is of major importance that all carpenters know what a passive house is and how it works. A day of education in the beginning, where for instance the importance of air tightness is explained, saves both money and time in the project.

Leadership

As a client it is important to have set up well defined building requirements for the planning team to work against. The client – or a project leader – needs to have done his homework well and must easily answer questions that occurs, both in the planning- and in the building process. The project leader or the local manager on the working site needs to have the authority to take own decisions. Waiting for answers both cause frustration and waste time in the project.

It is also very important that the project leader is a good listener and early can discover if something is wrong in the working group. The project leader must understand, and therefore communicate, signals indicating new or unexpected conditions that might cause problems. Experiences in these demonstration projects show that one important thing that prevents these unexpected incidents being discovered is that people hope to solve their own problems. The person it concerns tries as long as possible to keep the problem to himself and not ask for help or advice. It has been found very hard to admit a mistake or a lack of knowledge. To make it easier to ask for advice early, it is very important to have an open climate in the working group where signals like this are received in a good way. The project leader must focus on finding the best solutions for the project, not finding the scapegoat.

Well accomplished passive house projects are seen as good reference projects and are used as a base in future projects. The proud carpenters with their straight backs are priceless as advertisers that there is nothing complicated with building passive houses.

More components suitable for passive houses needed on the Swedish market

To get larger scale production of passive houses in Sweden, more components suitable for passive houses need to be available on the Swedish market. Examples of such components are:

- Supply air unit with heat exchanger – right now there is almost only one supply air device model that is used in all passive houses in Sweden. The competition must increase both for development, e.g. for devices with a lower need of electricity for fans, but also to get the prices down.
- Supply and exhaust air devices – the devices used in passive houses must be suitable to use with variable air temperatures and variable air flows. These devices could with advantage have a good design.
- To avoid too thick outer walls, new insulation materials can be used. These super-insulation materials must be further developed for instance to be suitable for storage on building sites and to decrease the costs of these materials.

- The numbers of windows with low U-values on the Swedish market are increasing. Further development of these important components is however necessary. There are only a handful of window producers on the Swedish market today, which is a very pleasant development during the last two years. These windows need to be more easily available on the building markets, so people can buy energy efficient windows without having to wait during a longer (i.e. too long) ordering process. Otherwise it is often more easy to buy the cheapest window available. If the products are easy to buy, the demand for energy efficient windows will increase and the prices can be lower. This is important also for the private home owners.
- There is a lack of entrance doors suitable for passive houses on the Swedish market. The one used in one of the demonstration projects is not available on the market. A development of entrance doors with low U-values is necessary.
- A combination of a heat exchanger and a heat pump – a compact unit- is very common in passive houses in Germany. The compact units deliver heat both to domestic hot water and to the supply air. The heat pump takes heat from both the exhaust air after the heat exchanger or from the outdoor air. There are at the moment no compact units developed for colder climates.

Right expectations

Demonstration projects are a good way to gain knowledge about passive houses. It is also very important to give the client the right expectations. No passive house construction will be good enough if you expect to get something else.

[Janson 2008] Janson, Ulla, *Passive houses in Sweden, Experiences from design and construction phase*. Licentiate thesis. Report EBD-H—08/9, Energy and Building Design, Lund University (2008).

The first experiences in Denmark with passive house design and use of architecturally optimised solar roofs

Peder Vejsig Pedersen

Director, M.sc.

Cenergia Energy Consultants

Herlev Hovedgade 195, st., 2730 Herlev, Denmark

Phone: +45 44 66 00 99, fax: +45 44 66 01 36, e-mail: pvp@cenergia.dk, www.cenergia.dk

Abstract

The first Danish passive house building project, Rønnebækhave II in Næstved approximately 100 km south of Copenhagen, was finished in February 2006 [1].

The project included a small two storey housing block with 8 apartments.

Builder was the Danish housing association Domea, and Cenergia Energy Consultants was responsible for the overall energy design which included use of a small ground coupled heat pump and use of solar DHW heating, as well as use of 5 kWp roof integrated PV modules which on a yearly basis should be able to cover the electricity use for the heat pump.

Monitoring of the energy use in the dwellings since the beginning 2007 has confirmed a low energy use in accordance with what was expected based on calculations.

The same concept with use of a solar energy roof to match the yearly energy use for operation was used in the SOLTAG project where a CO₂ neutral rooftop apartment was developed and exhibited in Copenhagen from the summer 2005 in a co-operation between the Velux company, Kuben Urban Renewal Denmark, Rubow Architects and Cenergia Energy Consultants, here according to the Danish low energy class 1 standard, (see also www.soltag.net).

And it has now been decided to realise a SOLTAG passive house project with 24 dwellings in Roskilde, about 35 km west of Copenhagen, based on this experience.

1. Rønnebækhave II in Næstved, the first passive housing project in Denmark

The Danish passive house project Rønnebækhave II in Næstved comprises a small housing block with 8 apartments realised according to the German passive house principles (fig. 1.1.).

The project was realised with support from the EU-Resurgence programme (www.resurgence.info) and it was connected to the “Builders for Sustainability” co-operation connected to the Danish Agency for Commerce and Housing.

Builder was the Danish housing association Domea with Suenson Architects as architect and with civil engineer Peder Vejsig Pedersen from Cenergia as initiator and responsible for the energy design. Erection of the passive housing project in Rønnebækhave II in Næstved was finished by February 2006.

To be able to live up to the German room heating demand which should not exceed 15 kWh/m², year it was necessary to purchase low energy windows from Germany with a documented U-value of 0.8 W/m² °C (manufacture Haußler), and an individual only 26 cm thick heat recovery unit R200, from the Danish ventilation company EcoVent, (see fig. 1.2.) was placed in a small technical room to enable a “dry” heat recovery efficiency of 85 % together with a very low electricity use.

EcoVent utilises a Danish produced air to air heat exchanger which clearly has a better performance than imported HRV heat exchangers which have “dry” heat recovery efficiencies around 72 – 75 % measured at the Technological Institute in Denmark except a Dutch plastic heat exchanger which is 82 % efficient but have a too high electricity use for the fans.

For two of the apartments in Rønnebækhave II ventilation air is preheated in the ground.

The apartments utilise a 28 m² shared solar DHW system from Arcon Solar Heating and individual 240 litre DHW tanks. Besides is used a ground coupled shared heat pump from IVT/Bosch in combination with air heating and floor heating. This is matched by PV electricity from a 5 kWp PV system in the roof on a yearly basis. (Gaia Solar manufacturer), so a CO₂ neutral design is obtained.

In fig. 1.3. is illustrated the energy frame value for the project. To this can be added that with a calculated energy use for heating and DHW of 23 kWh/m², year only $23/3.5 = 6.5$ kWh/m², year will be needed of electricity for the heat pump with a COP of 3.5. This is the same as the yearly PV production of the PV-modules which is 4250 kWh or 6.6 kWh/m², year.

The experiences with the passive housing project in Næstved has been very good, and here it can be mentioned that especially the balanced HRV systems have been very popular with the tenants where actually two families claim that they have avoided asthmatic symptoms since moving into the apartments.

Due to the limited knowledge concerning passive houses in Denmark, and the general policy concerning energy, at the time of erection it was very difficult to get the project financed and it was also difficult to get funding for monitoring and follow-up. However, it has been possible to realise monitoring since the spring of 2007 where also an extra electricity meter was installed for the heat pump so it was possible to document the actual COP value. The measurements document that it has been possible to obtain results very near to what was expected from calculations with an energy use for heating and DHW near 20-25 kWh/m², year.

Concerning practical operation experiences they have overall been good although there was a problem with a too simple floor heating control which had to be replaced to include temperature monitoring of the floor as basis of a good control.

Besides a problem of missing over temperature control of the solar DHW systems have also been mended.



Fig. 1.1.
50 m² PV-modules in Rønnebækhave II is mounted in the roof facing south in connection to a solar collector area of 28 m².



Fig. 1.2.
Heat recovery unit from EcoVent placed in a small technique room in the dwelling.

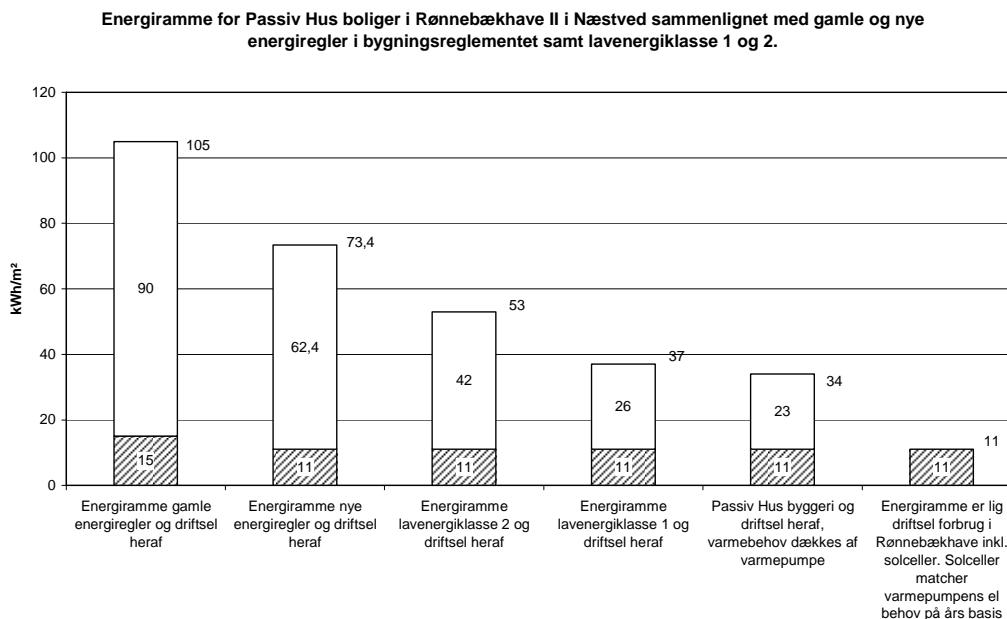

Table 1.1.
Energy frame for Passive House dwellings in Rønnebækshave II in Næstved. Here compared to low energy class 2 and 1 inclusive a passive house standard.

2. The SOLTAG prefabricated CO₂ neutral rooftop dwelling

A prototype of a new CO₂ neutral rooftop dwelling, which was build according to the new Danish low energy class 1 standard, was exhibited at Ørestaden in Copenhagen from August 2005 until the spring 2006 (see fig. (2.1)).

The prototype development has been supported by the EU-Demohouse project, The Copenhagen Urban Ecology Fund, The Danish Energy Agency and Elkraft-PSO together with a group of sponsors lead by the Velux company from Denmark. Co-ordination of the project has been facilitated by Cenergia and Kuben Urban Renewal Denmark, who together with Velux and Rubow Architects have developed the prototype housing unit. The innovative solar roof with air solar collector and PV-panels has been made by Roofing.dk/Ruukki and Danish Solar Energy, while the innovative heating and ventilation system has been made by Gilleje Cooling&Energy together with EcoVent.

The prefabricated rooftop dwelling was manufactured by the Danish company Jytas. (See also www.soltag.net)[5.6].



Fig. 2.1.
Prefabricated SOLTAG CO₂ neutral rooftop dwelling exhibited in Ørestad, Copenhagen from August 2005 till the spring 2006. It is now situated at Velux headquarters in Hørsholm.

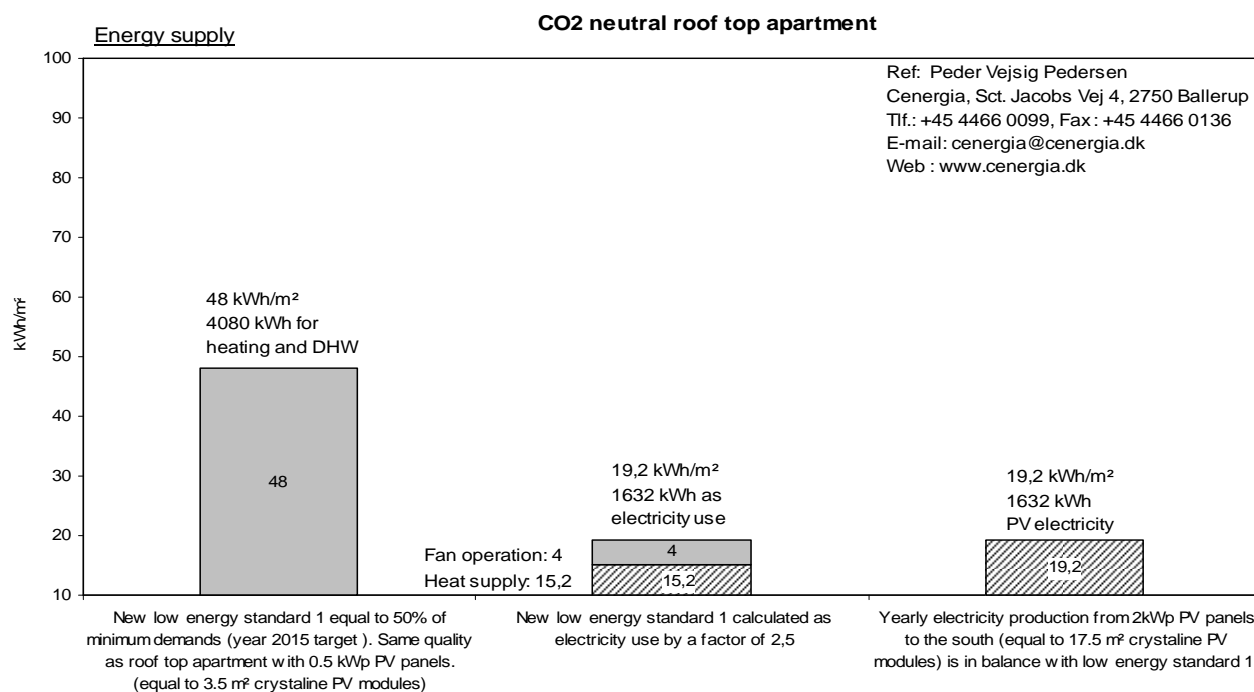

Table 2.1.
Energy balance of SOLTAG CO₂ neutral rooftop apartment.

The CO₂ neutral rooftop dwelling was designed according to an

“Energy Quality Design” philosophy: 6 steps to reduce energy consumption

1.	Prefabricated constructions without cold bridges and with a good airtightness. (Better than 0.6 l/s,m2 as natural ventilation rate)
2.	Use of heat recovery ventilation (HRV) with low electricity use. Extra costs of item 1 and 2 are only 10.000 – 15.000 DKK per apartment (1.350 – 2.000 Euro), based on use of a new thin EcoVent HRV unit which is easy to integrate. This is considered the cheapest way of obtaining the new Danish 2006 low energy demands with a 25 – 30% reduction in energy use. Experience from realised Danish housing projects has shown that item 1 + 2 alone can lead to a 50% reduction of the yearly heating bill and an improved indoor air climate without moisture problems.
3.	Use of low energy windows with a good daylighting transparency and at the same time avoidance of overheating problems.
4.	Use of solar domestic hot water (DHW) system to obtain a 50-65% reduction of the energy use for DHW. Extra costs 10.000 – 25.000 DKK per apartment (1.350 – 3.300 Euro).
5	Use of Photovoltaic (PV) modules to reach a desired or even a climate-neutral low-energy level. With 0.5 kWp PV panels, equal to 3.5 m² crystalline PV modules, a low energy class 1 quality can be obtained for the rooftop dwelling (50 % better than building regulations demand). Extra costs today 20.000 DKK (2.700 Euro). With an extra 2.0 kWp PV panels, equal to 14 m² crystalline PV modules, a zero energy and climate neutral energy design can be obtained on a yearly basis. Extra costs today 100.000 DKK (13.300 Euro). The use of PV energy is considered a very interesting energy option, because we know that we need to depend on renewables in the future and also because there has been a trend of a 50% price reduction in a 7 year period. In Germany 30.000 new jobs have been created in this industry in the last few years.

6. Use of an adapted energy supply for heating and DHW.
For a low-energy class 1 housing unit you only need a very small energy supply level on a yearly basis. All existing energy supply options can in principle be used (gas furnace, district heating, a small heat pump or electric heating). When a small air and solar roof based heat pump is used you obtain a good energy “quality” and at the same time avoid a separate energy supply (besides electricity). A competitive investment cost of the energy supply system at around 25.000 – 30.000 DKK per apartment (3.300 – 4.000 Euro) is possible. In any case it is very important to avoid heat losses from the energy supply system because a normal-size heat loss will mean a much higher relative percentage in low-energy dwellings.

3. SOLTAG power roofing and new CO₂ neutral passive house – housing project in Roskilde

Based on the very good results from the realised SOLTAG CO₂ neutral rooftop apartment (receiving the Danish Energy Saving Price 2005 and the Energy Globe Award for Denmark 2006), and which is now placed at the entrance to the Velux company headquarters in Denmark, it has now been decided to go into the development of a modular system for SOLTAG power roofs which can incorporate all necessary functions (PV electricity, solar thermal, daylight, ventilation, insulation etc.).

At present Velux already have modular systems for their roof windows and solar thermal collectors but a modular system which can also be used for PV production is missing.



Fig



Bredablik SOLTAG passive house design.

3.1 Soltag prototype.

During 2007 a SOLTAG power roofing secretariat has been established at Rubow Architects in Copenhagen and besides the actual work on developing new SOLTAG power roofing solutions on a new passive housing project (Bredablik) with 24 dwellings has been prepared to be established in Roskilde near Copenhagen. Here it is the idea to utilise a new developed SOLTAG power roofing system as basis of making the housing project CO₂ neutral.

The here mentioned activities and the general work on passive housing and SOLTAG designs are also very important in relation to a new Danish co-ordinated, EU-Concerto project, Green Solar Cities, where there will be demonstration activities in Valby in Copenhagen as well as in Salzburg in Austria. (See www.greensolarcities.com) [2], [4], [7], [8].

4. Proposed low energy classes for passive houses in Denmark

The German passive house standard is with respect to energy use for room heating a very strong tool to realise low energy building projects in the future where heating of a housing unit can actually be obtained by help of air heating. This can be done from the air you will anyway supply through your balanced heat recovery ventilation system (with 10 W/m² in energy supply).

In the same way the new Danish energy frame value system can also be considered as a strong tool to support low energy building. Here you calculate the energy frame value by adding the energy use for heating and domestic hot water together with the electricity use for operation, where the last item is first multiplied by 2.5 to take into account the higher primary energy value of electricity.

This is especially true for the new introduced minimum demand values combined with the use of the low energy classes 2 and 1 which at the same time are presented as the expected new minimum demands in year 2010 and 2015.

Since the passive house standard for room heating with 15 kWh/m², year is approximately 40 % better than the typical room heating level, connected to low energy class 1, then it is suggested that the low energy class level that is connected to a passive house design should also be better than low energy class 1. One idea could e.g. be to propose 3 improved low energy classes connected to passive house projects. This could e.g. be:

- A: 50 % of low energy class 1
- B: 33 % better than low energy class 1
- C: 25 % better than low energy class 1.

Here B represents an improved level which has the same increase in the energy frame value as low energy class 1 has compared to low energy class 2.

As an example of how this would work we can look at a 160 m² house which according to the Danish energy rules has an energy frame value of 70 kWh/m², year + 2200/(area) m² = 84 kWh/m², year which means that low energy class 1 will be 42 kWh/m², year. If we then choose a passive house low energy class B then the energy frame value can be calculated as: 42 kWh/m², year x 0.67 = 28 kWh/m², year with 15 kWh/m², year for room heating and use of domestic hot water with 6 kWh/m², year inclusive of solar DHW heating. Then there is only left: 28 – 15 – 6 = 7 kWh/m² year for electricity use for operation of pumps and fans.

To be able to have a reasonable value of 4 kWh/m², year for electricity use for operation equal to 10 kWh/m², year the difference of 10 – 7 = 3 kWh/m², year can be covered by help of PV-modules. This is equal to 480 kWh/year or in electricity 480/2.5 = 192 kWh/year. This can be covered by 0.25 kWp PV-modules equal to 1.5 – 2.5 m² PV-modules.

References

1. Pedersen, P. Vejsig (2006). CO₂ neutral low energy housing by help of PV- modules ISBN nr.: 978-87-90314-40-8.
2. Pedersen, P. Vejsig, Ingeborg Strassl (2008). Green Solar Cities. Paper for International Solar Cities Conference 2008 in Adelaide, Australia.
3. Pedersen, P. Vejsig (2002). Solenergi og Byøkologi, Nyt Teknisk forlag
4. Pedersen, P. Vejsig (2007), *Green Solar Cities*, Description of the EU-Concerto II project, Cenergia, Herlev, Denmark
5. Pedersen, P. Vejsig (2007), *Solar low energy building in Denmark*, SB07 Conference – Torino – Italy, 7th – 8th June 2007, Cenergia, Herlev, Denmark.
6. Pedersen, P. Vejsig (2006), *SOLTAG CO₂ Neutral Rooftop Apartment*, Cenergia, Herlev, Denmark.
7. Pedersen, P. Vejsig (2005), *PV and Architecture – Solar City Copenhagen*, Solar City Copenhagen, Cenergia, Herlev, Denmark.

MERA Multi-storey Building - Finnish Passive House

Riikka Holopainen, Juhani Laine & Mikko Saari, VTT Technical Research Centre of Finland
Mika Airaksela, Rakennusliike Reponen Oy
Jouni Tuomi, Meptek Oy

Technical Research Centre of Finland, VTT has co-ordinated the development of building technology that cuts the amount of energy required for heating in a block of flats by 70 per cent. The first apartment constructed with passive house technology was completed in the city of Espoo Finland, in 2005. Building of an entire block of flats utilising the same technology is scheduled to begin in 2008 and many more are in design phase.

Research on low-energy building in Finland has mainly focused on single-family houses. VTT is now co-ordinating work aimed at creating the prerequisites for the productisation of passive house building. VTT has been supervising research and development activities in which the requirements set for apartments clearly exceeded the current living comfort and technical building standards. VTT and a network of several companies have designed exterior walls, balcony doors and windows with excellent thermal insulation properties, as well as an integrated ventilation-heat recovery system that removes the need for radiators in the apartment. Currently, the building product and construction industries mainly settle for meeting the minimum criteria set for the field.



Figure 1. The first MERA apartment building constructed with passive house technology was completed in the city of Espoo Finland, in 2005.

MERA Building Concept

MERA is a new generation apartment house concept aiming at 30% heating energy consumption compared to present practice with apartment buildings. MERA is also the first multi-storey project where ventilation heating concept has been adopted in Finland. The five-storey concept building was built in Espoo 2005 (20 apartments, 1650 m²). The building has been monitored during one year. The results prove the targeted energy saving and good indoor air quality.

The MERA concept includes new innovative solutions:

- Ventilation heating unit with counter flow heat recovery, integrated optical freezing control and air heating coil for district heat, and DC fans.
- Prefabricated passive house concrete sandwich elements including brick tile facade.
- High performance wooden window with two sealed units (measured U = 0,80 W/m²K, glazing U = 0,5 W/m²K)

Performance /Indoor air	
Indoor air quality classification	S1 and S2
Emission rating of surface materials	M1
Cleanness classification of construction work	P1 and P2
Heating demand	
Heating power demand	15 – 25 W/m ²
Energy consumption of space heating	20 – 30 kWh/m ²
Ventilation heating	
Annual heat recovery efficiency ¹⁾	60 %
Supply air maximum temperature	50 °C
Ventilation sound levels	
Living room, bed rooms	22 dB(A)
Kitchen, bathroom, sauna	25 dB(A)
Specific fan power	1.3 kW/(m ³ /s)
1) Demand driven anti-freeze system	

Table 1. Technical specification of the MERA building.

The placement of the kitchen and wet areas in the passive house apartment helps avoid the heat losses due to the customary long pipelines. Particular care was taken during construction to make the joints between the building elements, windows and doors airtight and avoid thermal bridges. All these details contribute to the overall reduction in heating energy consumption (Figure 2 and 3).

Reference building 100 %

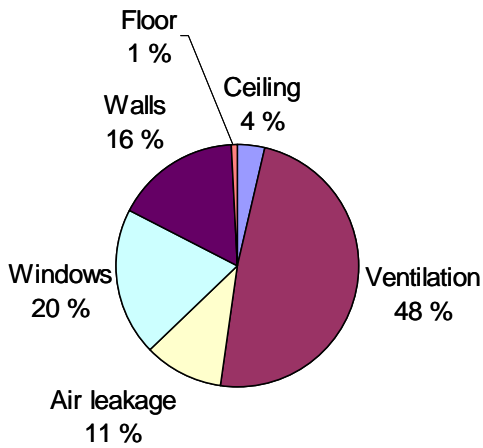

MERA building 31 %

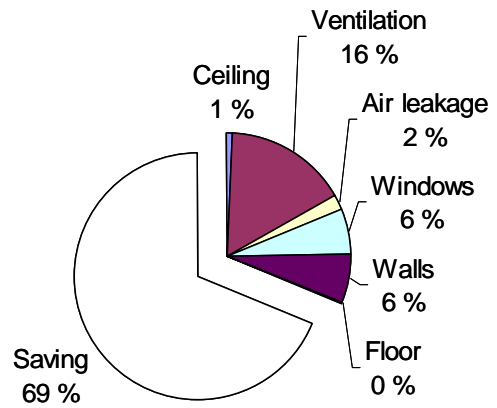

Figure 2. Reduction of space heating energy consumption in MERA building compare to reference building.

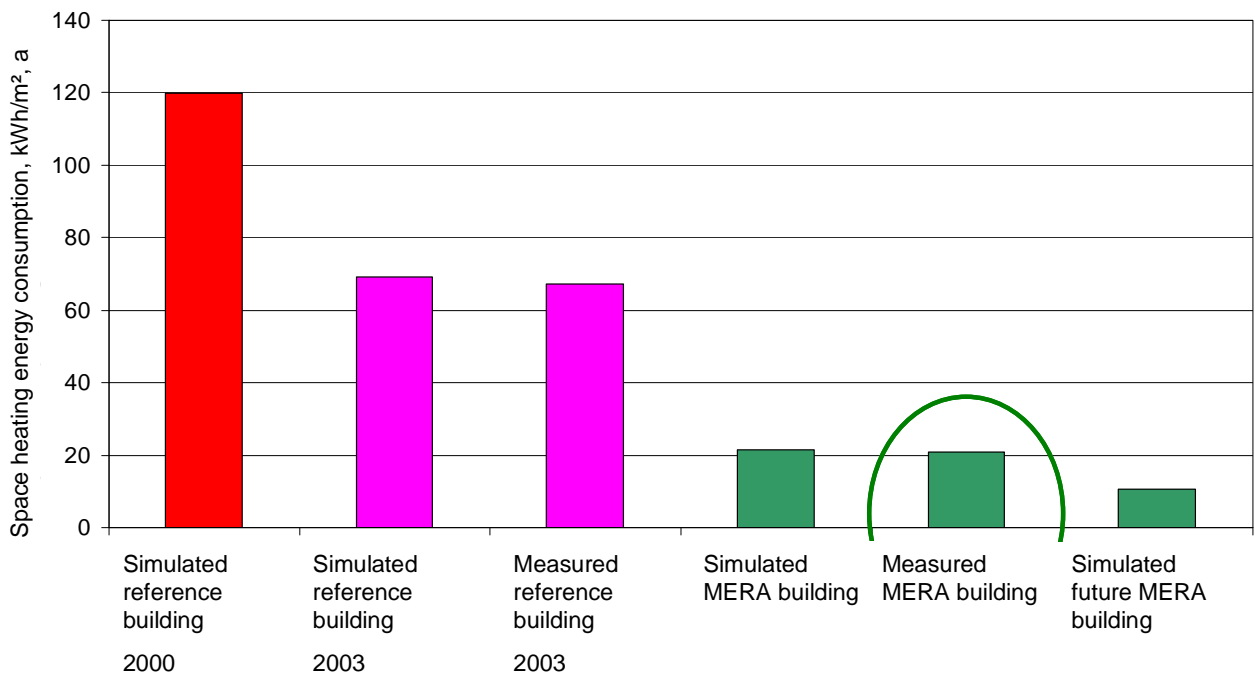

Figure 3. Simulated and measured heating energy consumption of MERA building.

Temperature control in MERA building

The passive house apartment built in Espoo exploits the heat generated by the occupants and the household equipment. This heat is recovered with the new ventilation heat recovery and heating system (Figure 4). Thus external energy, produced with the same system, is only required for heating during two or three months a year (Figure 5). In the summer the apartment is kept cool as a combined result of structural solutions and ventilation (Figure 6).

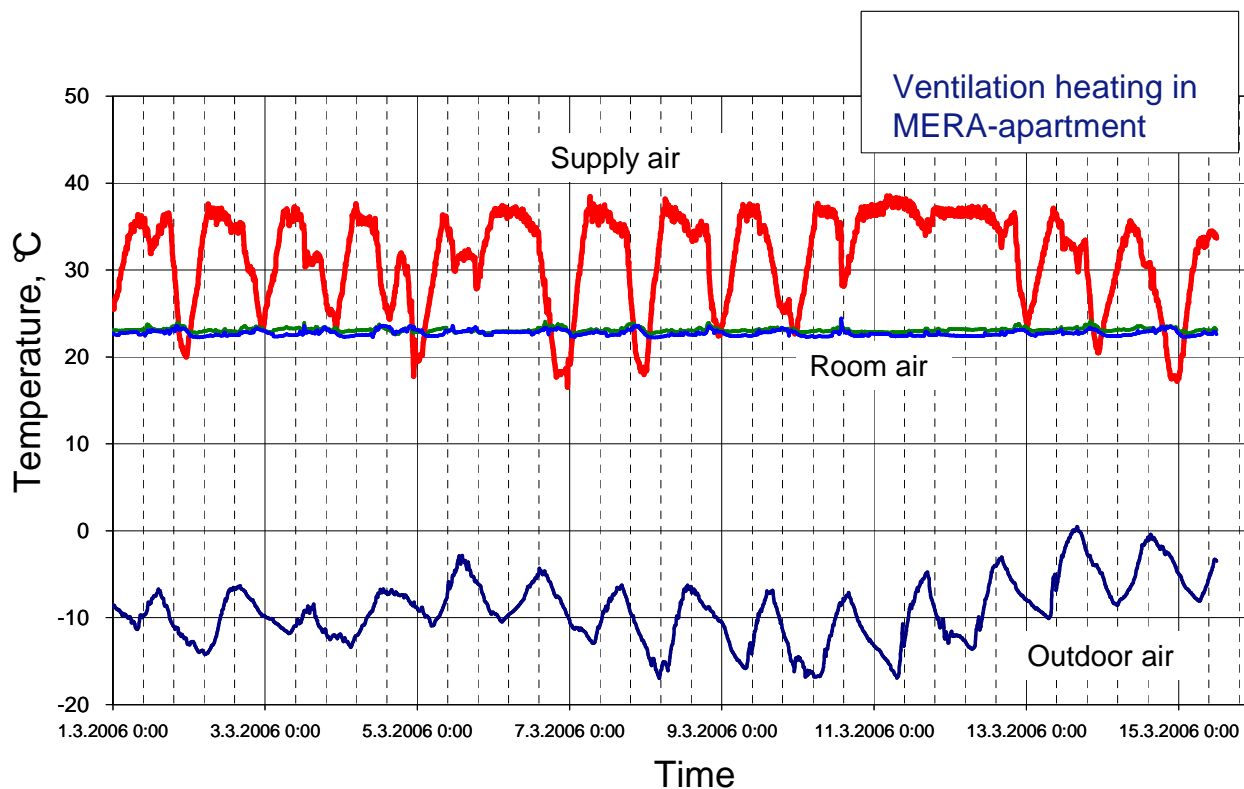

Figure 4. Measured temperatures of MERA ventilation heating system in Espoo.

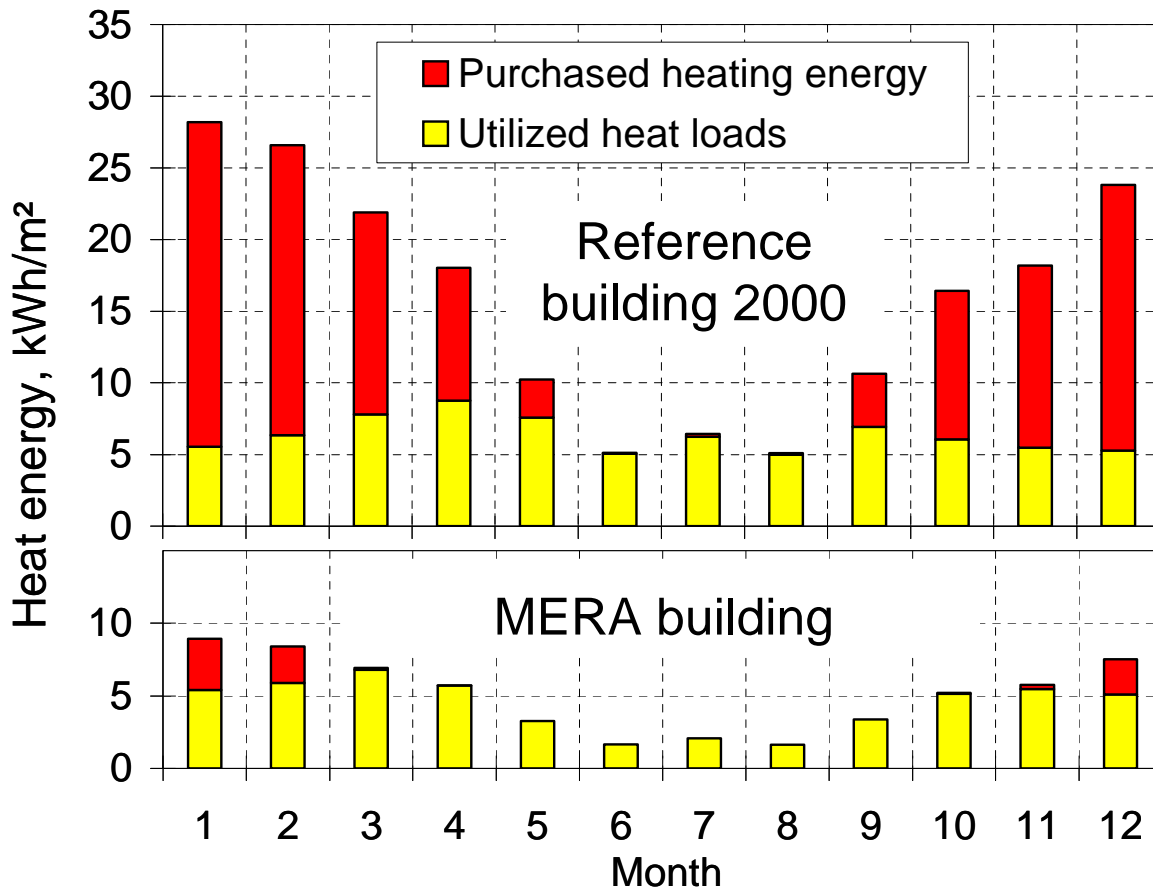

Figure 5. Massive structures are utilized as daily heat storage in the MERA building. Purchased heating energy is needed only three months a year.

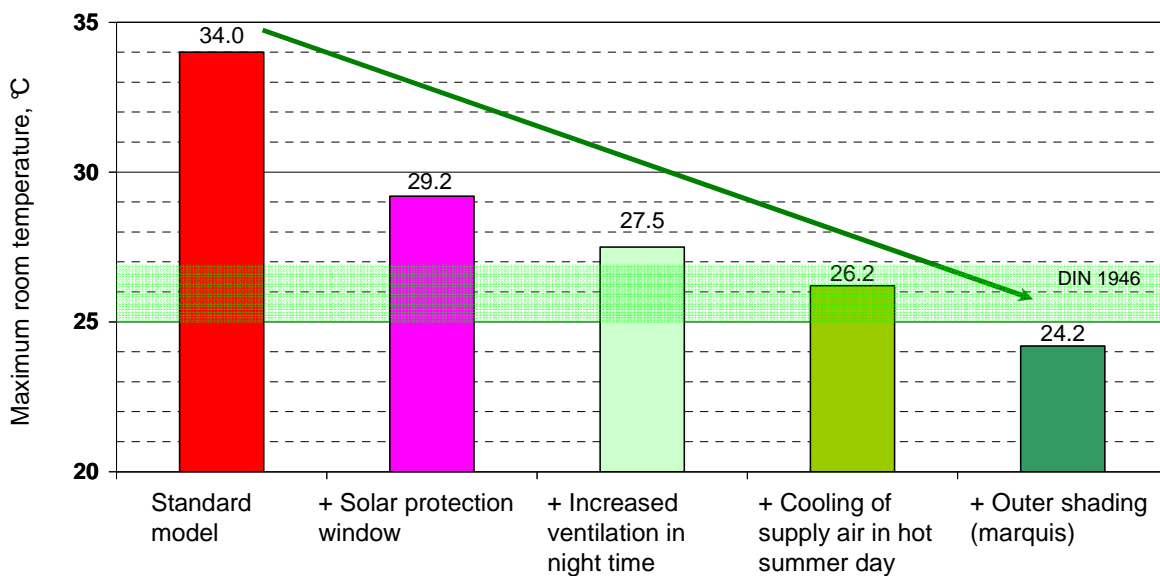

Figure 6. In the summer the MERA apartment is kept cool as a combined result of passive solutions and ventilation.

Construction costs and savings

Passive house technology only increases the construction cost by some one or two per cent, which will be soon covered by long-term savings in heating energy consumption. Compared with building construction according to current standards, the savings in heating costs achieved in one block of flats built with passive house technology would total 50,000 Euro in ten years, if energy prices continue to rise by three to six per cent annually (Figure 7). With the same price increase rate, the savings accrued in 50 years would total 400,000 to 1,000,000 Euro. Passive houses received the best energy performance classification of energy performance certificates for buildings.

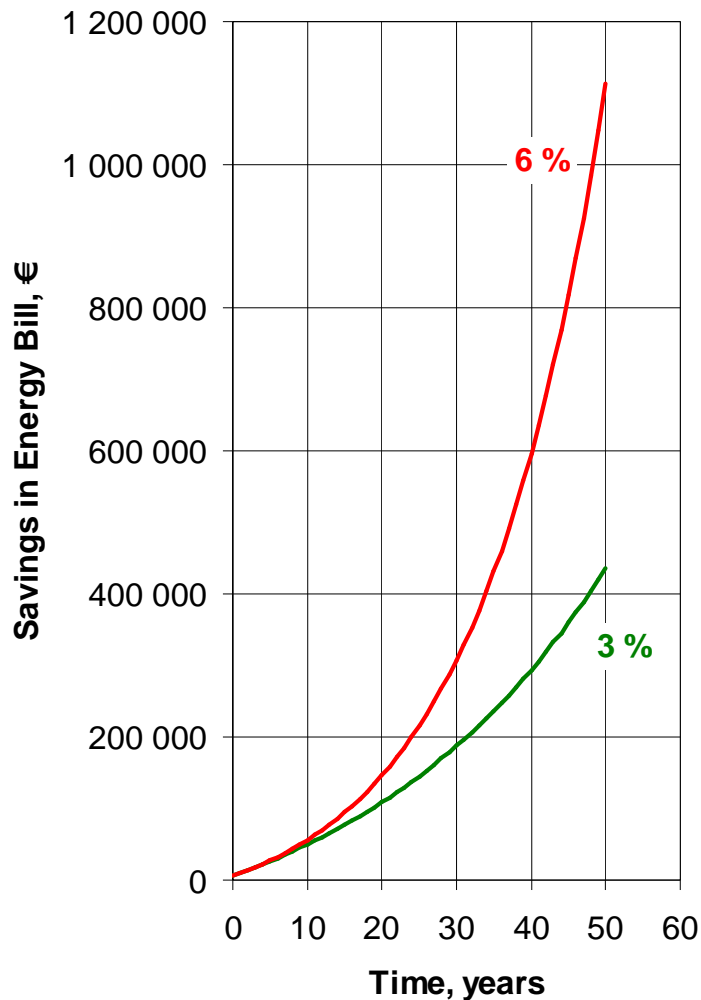

Figure 7. Calculated savings in energy bill of MERA building when energy prices go up by 3 or 6 % per year.

Energy saving potential

Energy efficient building with an inexpensive lifespan would also be extremely profitable in terms of national economy. If new residential buildings were constructed using the new passive house technology, the savings achieved would correspond to the annual district heating consumption in the City of Helsinki (currently 7.2 TWh) by 2030 (Figure 8).

For an individual corporation producing thousands of apartments annually - such as Helsinki City, SATO and VVO – passive houses would become a highly profitable investment in less than ten years.

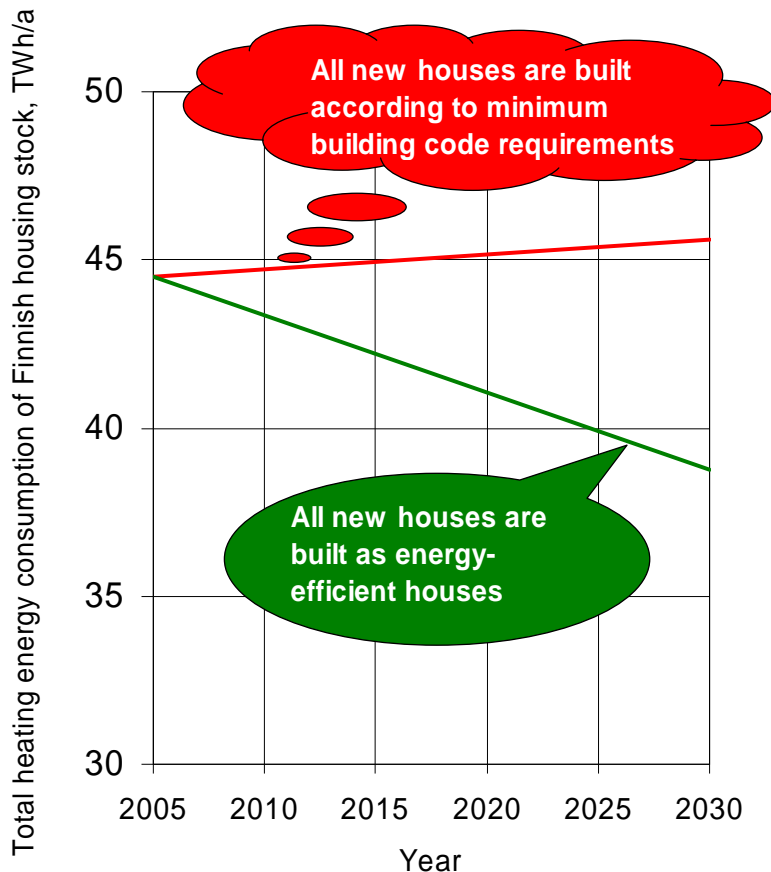

Figure 8. Heating energy saving potential in Finnish housing stock during next 25 years.

Acknowledgement

The low-energy apartment was developed by VTT, Mikkeli University Of Applied Sciences (Mamk), Rakennusliike Reponen Oy, Meptek Oy and Skaala Windows and Doors. The project also received funding from Tekes, the Finnish Funding Agency for Technology and Innovation.

Session 2

Passive house components and solutions

Jørn Stene

CO₂ Heat Pump System for Space Heating and Hot Water Heating in Low-Energy Houses and Passive Houses36

Henrik Davidsson, Bengt Perers, Björn Karlsson

Performance of a multifunctional PV/T hybrid solar window44

Tor Helge Dokka, Leif Amdahl

Forenklet og kostnadseffektiv vannbåren varme skreddersydd til passivhus-leiligheter52

Jørn Stene, Tore Hjerkin.

High-Efficiency Heat Pump Water Heater System for Apartment Buildings of Passive House Standard.....57

CO₂ Heat Pump System for Space Heating and Hot Water Heating in Low-Energy Houses and Passive Houses

J. Stene

SINTEF Energy Research, Dept. of Energy Processes
Kolbjørn Hejes vei 1D, 7465 Trondheim, Norway
Jorn.Stene@sintef.no

Low-energy and passive houses are superinsulated and air-tight buildings where the space heating demand is considerably lower than that of buildings constructed in accordance with prevailing buildings codes. Due to the low space heating demand, the annual heating demand for domestic hot water (DHW) typically constitutes 50 to 85% of the total annual heating demand for the residence.

A heat pump system can be used to cover the heating demands in low-energy houses and passive houses. The heat pump can be designed as a stand-alone system, i.e. a heat pump water heater in combination with a separate unit for space heating, or be an integrated unit for combined space heating and hot water heating. Due to compact design, the latter system is most likely to achieve the lowest investment and installation costs and with that the best profitability.

Integrated residential heat pump systems using carbon dioxide (CO₂, R744) as a working fluid can achieve a high Coefficient of Performance (COP) due to the unique characteristics of the CO₂ heat pump cycle. Integrated CO₂ heat pumps for combined space heating and hot water heating can be designed to utilize different heat sources such as ground, exhaust ventilation air, ambient air or a combination of exhaust ventilation air and ambient air.

Different integrated CO₂ heat pump systems have been investigated, focusing on the design of the heat rejection heat exchanger (gas cooler) and the DHW system. It was found that a counter-flow tripartite CO₂ gas cooler in combination with an external single-shell DHW tank and a low-temperature heat distribution system would enable production of DHW from 60 to 85°C without electric reheating, and contribute to the highest possible COP for the CO₂ heat pump system. The Seasonal Performance Factor (SPF) for a prototype brine-to-water CO₂ heat pump was calculated on the basis of extensive laboratory measurements and compared with the performance of a state-of-the-art high-efficiency brine-to-water heat pump. At DHW heating demand ratios above approx. 50%, the CO₂ heat pump outperformed the state-of-the-art heat pump. Consequently, an integrated CO₂ heat pump system equipped with a tripartite gas cooler represents a promising, high-efficiency system for combined space heating and DHW heating in low-energy and passive houses. The results presupposes the use of a low-temperature space heating system and optimized design of the DHW tank in order to minimize thermodynamic losses caused by mixing of hot/cold water and conductive heat transfer inside the tank.

1. Heating Demands in Low-Energy and Passive Houses

In low-energy houses and passive houses the space heating demand and the ventilation loss have been greatly reduced compared to houses constructed in accordance with prevailing building codes. This has been made possible by better insulated and more air-tight building envelopes, advanced ventilation systems with high-efficiency heat recovery and utilization of passive solar heating. Since the DHW heating demand remains more or less constant, the annual heating demand for DHW typically constitutes 50 to 85% of the total annual heating

demand in Scandinavian residences. I.e. the annual DHW heating demand ratio ranges from 0.50 to 0.85 [Breembroek and Dieleman, 2001].

Figure 1 shows, as an example, the calculated monthly space heating demand and DHW heating demand [kWh/month] for a 104 m² semi-detached house of different standards in Oslo, Norway [Dokka and Hermstad, 2006]. The different standards of the building envelope correspond to a house constructed according the Norwegian building codes of 1997 (BF97), a low-energy house (Energy rating B), a passive house (Energy rating A) and a passive house+ (Energy rating A+). The average monthly DHW heating demand is about 335 kWh/month (4,000 kWh/year), which is the estimated average value for Norwegian homes [Breembroek and Dieleman, 2001].

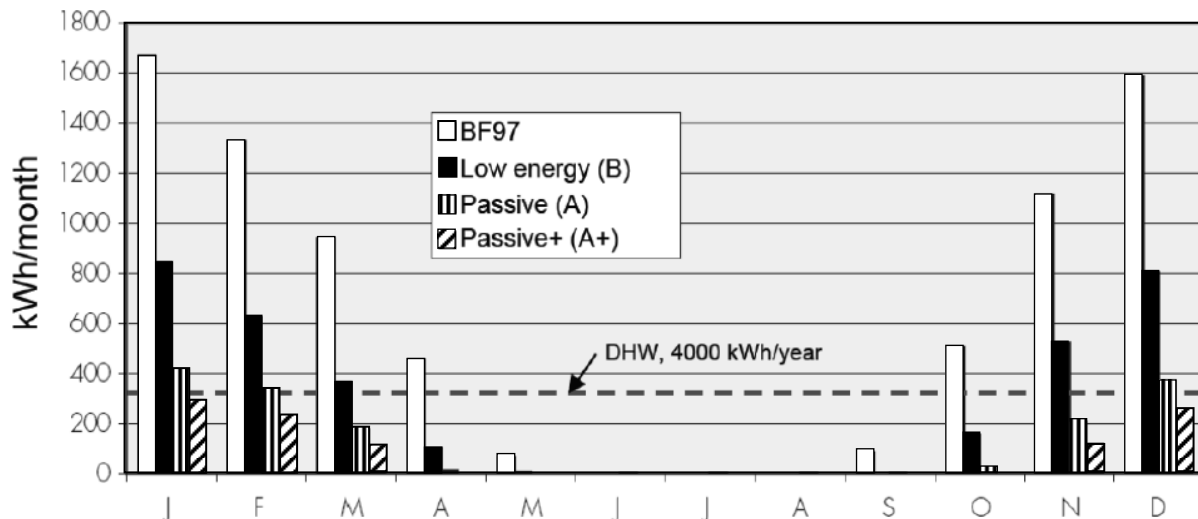

Figure 1 Example – Calculated monthly space heating demand and DHW heating demand for a 104 m² semi-detached house in Oslo, Norway constructed according to different building standards [Dokka and Hermstad, 2006].

The house constructed according to BF97 has an annual space heating period of 9 month/year, while the space heating periods for the low-energy house (B), the passive house (A) and the passive house+ (A+) are about 7, 6 and 5 months, respectively. The monthly heating demand for DHW is equal to or higher than the monthly space heating demands during the entire year for the passive houses (A and A+), while the monthly space heating demand is higher than the average DHW heating demand during roughly 4 month per year for a low-energy house (B). Consequently, it is important that heat pump systems for low-energy and passive houses are designed for high energy efficiency in DHW mode.

2. Analysis of Integrated Residential CO₂ Heat Pump Systems

A heat pump system can be used to cover the heating demands in low-energy houses and passive houses. The heat pump system can be designed as a stand-alone system, i.e. a heat pump water heater in combination with a separate unit for space heating, or be an integrated unit for combined space heating and hot water heating. Due to compact design, the latter system is most likely to achieve the lowest investment and installation costs and with that the best profitability. There exists a large number of designs for integrated heat pump systems with conventional working fluids, and the main differences are related to the design and operation of the DHW system. The most common systems are double-shell tank system, desuperheater system, shuttle-valve system and two-stage DHW system.

2.1 Main Characteristics of CO₂ Heat Pumps

Carbon dioxide (CO₂, R744) is one of the few non-toxic, non-flammable working fluids that neither contributes to ozone depletion nor global warming. CO₂ therefore represents an interesting long-term alternative to the

commonly used HFC working fluids. CO₂ has excellent thermophysical properties, and by utilizing these properties by means of optimized component and system design for the heat pump unit, the DHW system and the heat distribution system, high energy efficiency can be achieved.

CO₂ has an especially low critical temperature (31.1°C) and high critical pressure (73.8 bar). As a consequence, the operating pressure in CO₂ heat pump systems will typically be 5 to 10 times higher than that of standard heat pumps, i.e. 20 to 40 bar in the evaporator and 80 to 130 bar during heat rejection. Due to the low critical temperature most CO₂ heat pumps operate in a so-called *transcritical cycle* with evaporation at subcritical pressure and heat rejection at supercritical pressure ($p > 73.8$ bar). Unlike a subcritical heat pump cycle, heat is not given off by means of condensation of the working fluid in a condenser but by cooling of high-pressure CO₂ gas in a heat exchanger (gas cooler). The temperature drop for the CO₂ gas during heat rejection is denoted the *temperature glide*. Figure 2 shows the principle of the transcritical CO₂ heat pump cycle in a Temperature-Enthalpy (T-h) diagram.

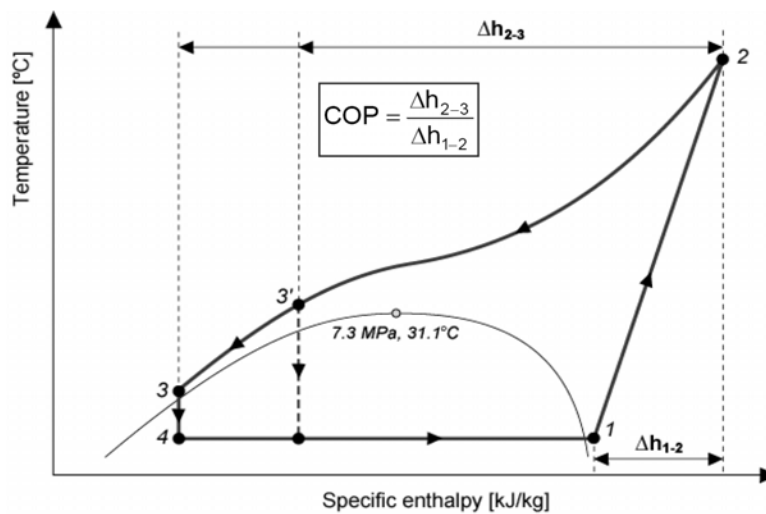

Figure 2 The transcritical CO₂ heat pump cycle in a T-h diagram. 1-2: Compression, 2-3: Heat rejection in a gas cooler, 3-4: Expansion/throttling, 4-1: Evaporation.

The main factors that determine the Coefficient of Performance (COP) for a single-stage CO₂ heat pump are the evaporation temperature, the overall isentropic efficiency for the compressor, the optimum gas cooler pressure, the CO₂ outlet temperature in the gas cooler, and possible recovery of expansion energy by means of an ejector or an expander.

Since the discharge gas temperature from the compressor in a CO₂ heat pump cycle is relatively high (>80°C), a CO₂ heat pump can meet high-temperature heating demands. However, in order to achieve a high COP for a CO₂ heat pump system, it is essential that *useful heat* is rejected over a large temperature range, resulting in a large enthalpy difference for the CO₂ in the gas cooler ($h_2 - h_3$) and a relatively low CO₂ temperature (t_3) before the expansion/throttling valve. This in turn presupposes a relatively low inlet water temperature in the gas cooler, i.e. a low return temperature in the (hydraulic) heat distribution system and/or a low inlet water temperature from the DHW tank.

The input power to the compressor is more or less proportional to the gas cooler pressure, i.e. the higher the gas cooler pressure, the lower the COP. Consequently, CO₂ heat pumps should preferably be designed for a moderate optimum gas cooler pressure.

Integrated heat pump systems (IHPS) provide both space heating and hot water heating, and the heat is normally rejected to a hydronic heat distribution system. An integrated heat pump system can be designed for high energy efficiency, but in the design process there will always be a trade-off between technical solutions that reduce the thermodynamic losses in the system, and first costs.

The main operating modes of an integrated CO₂ heat pump system are:

- *DHW mode* – heating of domestic hot water (DHW)
- *SH mode* – space heating
- *Combined mode* – simultaneous space heating and DHW heating

2.2 Testing and Evaluation of a Prototype CO₂ Heat Pump System

A 6.5 kW prototype brine-to-water CO₂ heat pump system for space heating and DHW heating has been extensively tested and analyzed (Stene, 2004/2006). A large number of different gas cooler configurations were evaluated, and it was found that *an external counter-flow tripartite gas cooler for preheating of DHW, low-temperature space heating and reheating of DHW*, would enable production of DHW in the required temperature range from 60 to 85°C, and contribute to the highest possible COP for the heat pump unit. Figure 3 shows the principle of the integrated CO₂ heat pump system.

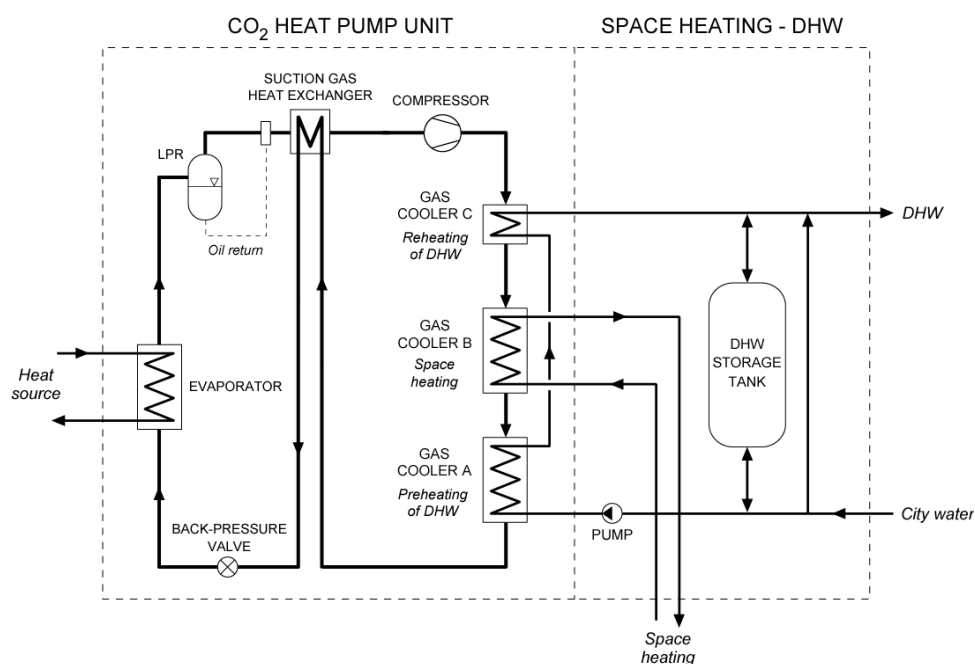

Figure 3 Principle design of the prototype brine-to-water integrated CO₂ heat pump system.

The prototype CO₂ heat pump unit was equipped with a hermetic rolling piston compressor, a tripartite counter-flow tube-in-tube gas cooler and a counter-flow tube-in-tube suction gas heat exchanger. An expansion valve (back-pressure valve) and a low-pressure liquid receiver (LPR) were used to control the pressure in the tripartite gas cooler. Gas cooler units A and C were connected to an unvented single-shell DHW storage tank and an inverter controlled pump by means of a closed water loop. Gas cooler unit B was connected to a low-temperature hydronic heat distribution system.

The integrated CO₂ heat pump unit was tested in three different operating modes. 1) Simultaneous space heating and DHW heating (*Combined mode*), 2) Hot water heating (*DHW mode*) and 3) Space heating (*SH mode*). During tapping of DHW, hot water was delivered at the tapping site, while cold city water entered the bottom of the DHW tank. During charging of the DHW tank in the Combined and DHW modes, the cold city water from the bottom of the DHW tank was pumped through gas cooler units A and C, heated to the set-point temperature, and returned at the top of the tank. The CO₂ system was tested at 40/35°C, 35/30°C or 33/28°C supply/return temperature in the SH system, and 60°C, 70°C or 80°C in the DHW system.

The heat rejection processes in the three different operating modes are illustrated in temperature-enthalpy diagrams in Figure 4. The supply/return temperature for the floor heating system were 35/30°C, while the city

water temperature and the set-point for the DHW were 6.5 and 70°C, respectively. In the Combined mode, the so-called *DHW heating capacity ratio* was about 45%, which means that 45% of the total heating capacity of the tripartite gas cooler was used for hot water heating.

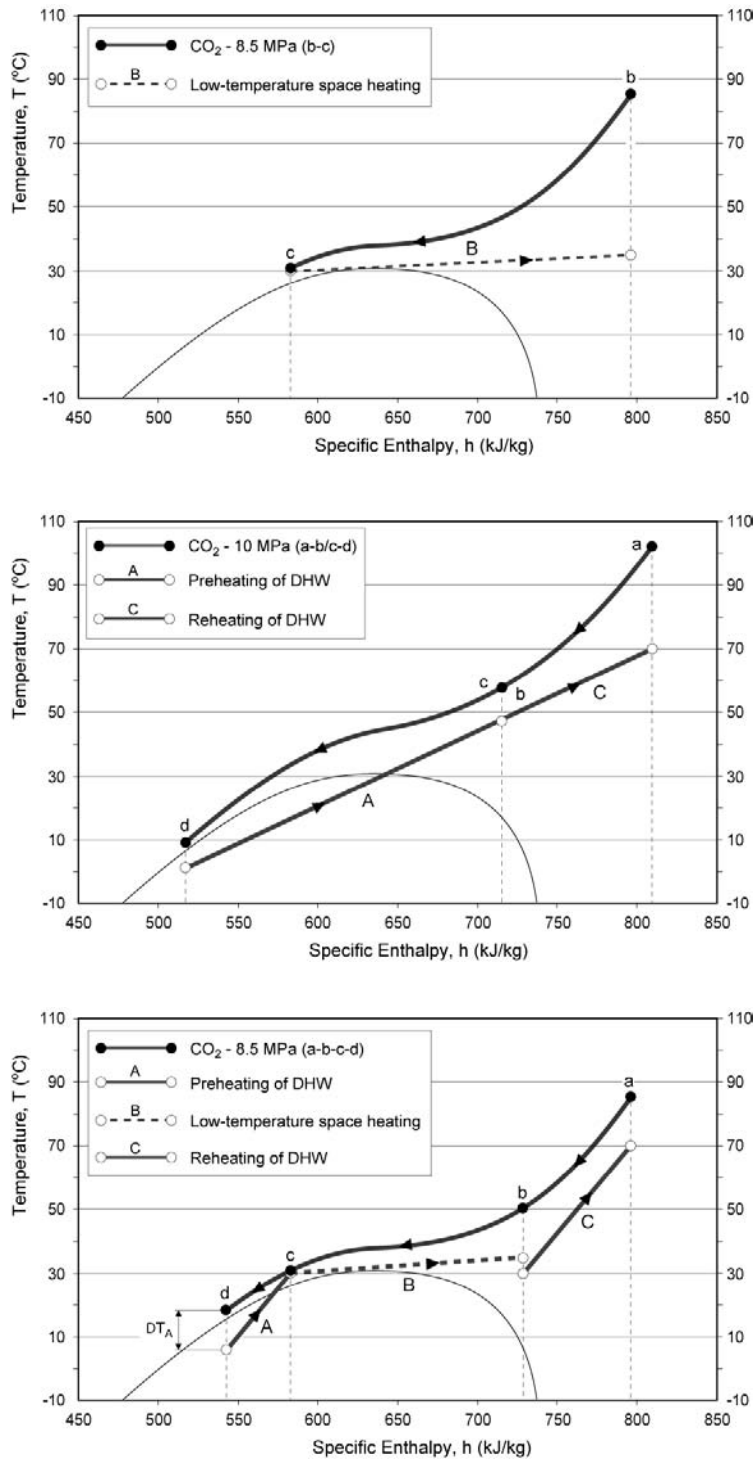

Figure 4 Example – Illustration of the heat rejection process for an integrated CO₂ heat pump in Space heating (SH) mode (35/30°C), DHW mode (70°C) and Combined mode (35/30°C, 70°C). The optimum gas cooler pressures were 85 and 100 bar.

The COP in the Combined mode was 2-10% higher than that of DHW mode due to the moderate optimum gas cooler pressure (85-95 bar) and the relatively low CO₂ outlet temperature from the tripartite gas cooler caused by the excellent temperature fit between the CO₂ and the water.

The COP in the SH mode was 20-30% lower than that of the Combined mode. This was a result of the poor temperature fit between the CO₂ and the water, and the fact that the CO₂ outlet temperature from the gas cooler was limited by the relatively high return temperature in the space heating system.

2.3 Comparison of Seasonal Energy Efficiency

The Seasonal Performance Factor (SPF) for the prototype CO₂ heat pump unit and a state-of-the-art high-efficiency brine-to-water heat pump was calculated, assuming constant inlet brine temperature for the evaporator (0°C) and constant temperature levels in the space heating system (35/30°C) and the DHW system (10/60°C). An improved CO₂ heat pump unit with 10% higher COP than the prototype system was also investigated in order to demonstrate the future potential of the CO₂ system. Higher COP can be achieved by using a more energy efficient compressor, optimizing the tripartite gas cooler or replacing the throttling valve by an ejector. The latter is capable of increasing the COP by typically 10 to 20% (Stene, 2004). For the CO₂ heat pump systems, the thermodynamic losses in the DHW tank due to mixing and internal conductive heat transfer were not included when calculating the SPF.

Table 1 shows the measured COPs for the heat pump systems at the selected operating conditions.

Table 1 Measured COPs for the brine-to-water heat pump systems.

Prototype CO₂ heat pump	<ul style="list-style-type: none"> • COP = 3.0 – SH mode at 35/30°C • COP = 3.8 – DHW mode at 10/60°C – no electric reheating • COP = 3.9 – Combined mode at 35/30°C and 10/60°C
Improved CO₂ heat pump	<ul style="list-style-type: none"> • COP = 3.3 – SH mode at 35/30°C • COP = 4.2 – DHW mode at 10/60°C – no electric reheating • COP = 4.3 – Combined mode at 35/30°C and 10/60°C
State-of-the-art heat pump	<ul style="list-style-type: none"> • COP = 4.8 – SH mode at 35/30°C • COP = 3.0 – DHW mode at 10/60°C – no electric reheating

Table 1 shows that the integrated CO₂ heat pumps and the state-of-the-art heat pump have reversed COP characteristics, i.e. the CO₂ units achieve the highest COP during operation in the DHW mode and the Combined mode, whereas the state-of-the-art unit achieves the highest COP in the SH mode.

Figure 5 shows the calculated SPFs for the three residential heat pump systems during monovalent operation presented as a function of the seasonal DHW heating demand ratio.

At low DHW heating demand ratios, the state-of-the-art heat pump was more efficient than the CO₂ systems due to their poor COP during operation in the SH mode. At increasing DHW heating demand ratios, the SPFs of the CO₂ systems were gradually improved, since an increasing part of the heating demand was covered by operation in the Combined mode and the DHW mode. On the other hand, the SPF for the state-of-the-art heat pump dropped quite rapidly with increasing DHW heating demand, since the COP during operation in the DHW mode was about 35% lower than that of the SH mode.

At the actual operating conditions, the break-even for the prototype CO₂ system occurred at a DHW heating demand ratio around 60%, whereas the break-even for the improved CO₂ system was about 10 percentage points lower.

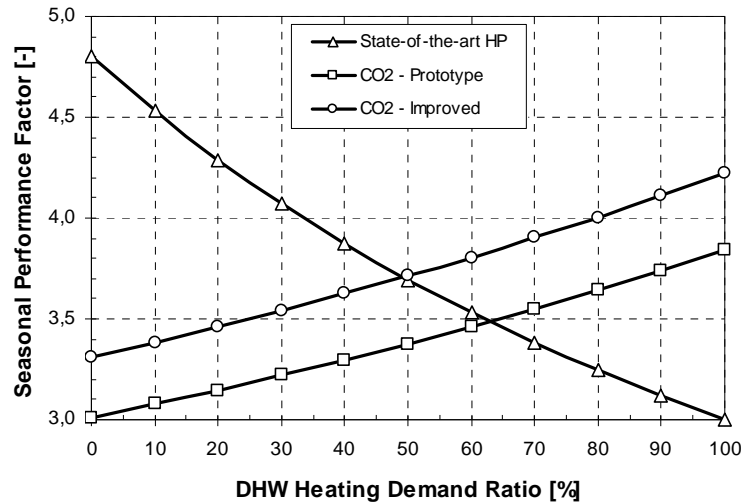

Figure 5 Calculated SPF during monovalent operation for a high-efficiency state-of-the-art heat pump, the prototype CO₂ heat pump and an improved CO₂ heat pump.

In existing houses where the DHW heating demand ratio typically ranges from 10 to 30%, a state-of-the-art high-efficiency heat pump system will be more energy efficient than an integrated single-stage CO₂ heat pump system. However, *in low-energy houses and passive houses, where the DHW heating demand ratio ranges from 50 to 80%, an integrated CO₂ heat pump system with a tripartite gas cooler will outperform the most energy efficient heat pump systems on the market.*

At 70% DHW heating demand ratio, the COP for the improved CO₂ heat pump is about 3.9. This corresponds to a net energy saving of about 75% compared with a direct electric heating system.

2.4 CO₂ Heat Pumps in Passive Houses – Application Example

A CO₂ heat pump system with a tripartite gas cooler for heating of low-energy houses and passive houses can be designed to utilize different heat sources. In Germany 40-50% of all passive houses are using an integrated heat pump system for space heating and hot water heating [Bühning, 2005]. The most common heat source is ventilation air, often in combination with ambient that is preheated in a ground heat exchanger (GHE¹). Figure 6 shows a principle sketch of a residential CO₂ heat pump system for a passive house using ventilation air and ambient air as heat sources (Viessmann, 2008).

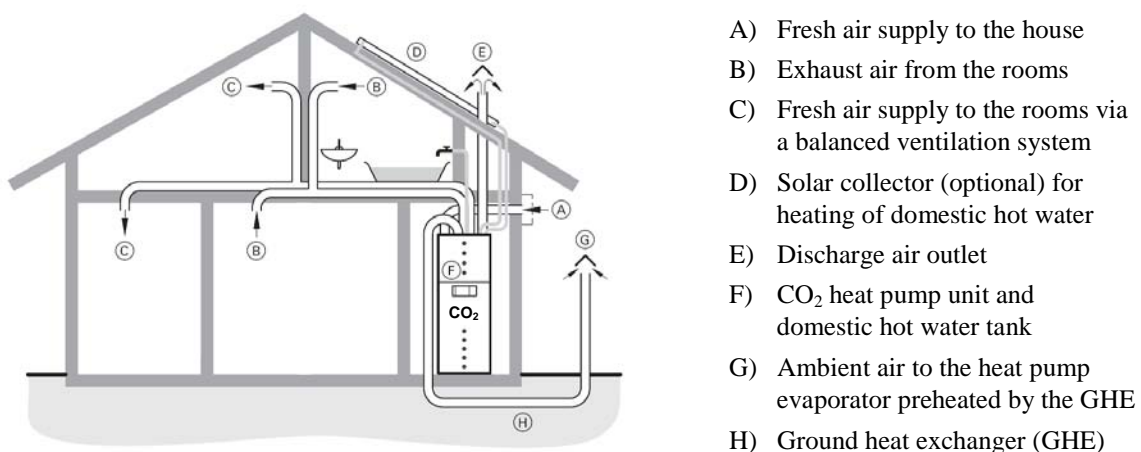

Figure 6 Example – CO₂ heat pump installation in a passive house (Viessmann, 2008).

¹ GHE – Approx. 15 meter long OD 200 mm plastic tube located around the house at about 1 meter below ground level

Ground (soil) is also a heat source of current interest for CO₂ heat pumps in low-energy and passive houses. In these systems the evaporator tubes (direct system) or a OD 40 mm PE tube with circulating anti-freeze fluid (indirect system) is installed horizontally in the ground about 0.8-1.5 meter below the ground level. Due to the relatively low heating capacity of the heat pump unit in a passive house (2-3 kW), a relatively small ground space is required for the ground-heat exchanger.

3. Conclusion

Integrated residential heat pump systems using carbon dioxide (CO₂, R744) as a working fluid can achieve high energy efficiency due to the unique characteristics of the CO₂ heat pump cycle. Different integrated CO₂ heat pump systems have been investigated, focusing on the design of the heat rejection heat exchanger (gas cooler) and the DHW system. It was found that a counter-flow tripartite CO₂ gas cooler in combination with an external single-shell hot water tank and a low-temperature heat distribution system, would enable production of DHW from 60 to 85°C without electric reheating and contribute to the highest possible COP for the CO₂ heat pump system. The Seasonal Performance Factor (SPF) for a prototype brine-to-water CO₂ heat pump was calculated on the basis of laboratory measurements and compared with the performance of a high-efficiency state-of-the-art brine-to-water heat pump unit. At DHW heating demand ratios above approximately 50%, the CO₂ heat pump system outperformed the state-of-the-art heat pump system. Consequently, integrated CO₂ heat pump systems equipped with a tripartite gas cooler represent a promising, high-efficiency system for combined space heating and DHW heating in low-energy houses and passive houses. In passive houses the most interesting heat sources includes ground (direct expansion system), ventilation air or a combination of ventilation air and ambient air.

4. References

- Breembroek, G., Dieleman, M., 2001: *Domestic Heating and Cooling Distribution and Ventilation Systems and their Use with Residential Heat Pumps*. IEA Heat Pump Centre Analysis Report HPC-AR8. ISBN 90-72741-40-8.
- Bühring, A., 2005: Bühring, A., 2005: *Development and Measurement of Compact Heating and Ventilation Devices with Integrated Exhaust Air Heat Pump for High-Performance Houses*. Proceedings fra 8. IEA Heat Pump Conference, Las Vegas, USA, May 30 – June 2, 2005.
- Dokka, T.H., Hermstad, K., 2006: *Energieffektive boliger for framtiden – en håndbok for planlegging av passivhus og lavenergihus (Energy Efficient Houses for the Future – A Handbook for Planning of Passive Houses and Low-Energy Houses)*. Norwegian final report from ECBCS Annex 38, Sustainable Solar Housing. SINTEF Building and Infrastructure.
- Stene, J., 2004: *Residential CO₂ Heat Pump System for Combined Space Heating and Hot Water Heating*. Doctoral Thesis at the Norwegian University of Technology and Science, Dept. of Energy and Process Engineering, 2004:53. ISBN 82-471-6316-0.
- Stene, J., 2006: *Residential CO₂ Heat Pumps for Combined Space Heating and Hot Water Heating – System Design, Test Procedures and Calculation of SPF*. Report no. TR A6102. SINTEF Energy Research, Norway.
- Viessmann, 2008: *Compact Energy Tower für das Passivhaus – Vitotres 343*. Information from Viessmann Werke GmbH&Co KG, Germany

Performance of a multifunctional PV/T hybrid solar window

Henrik Davidsson, Bengt Perers and Björn Karlsson
Div. of Energy and Building Design, Dept. of Architecture and Built Environment
P.O. Box 118, S-22100 Sweden

Abstract

A PV/T collector have been developed and evaluated at the department of Energy and Building Design at the Technical University of Lund, LTH in Sweden. The PV/T, a “multifunctional solar window” made of PV cells laminated on solar absorbers, is placed in a window behind the glazing. The solar window is built into a single family house, Solgården, in Älvkarleö outside Gävle in the eastern part of Sweden. To reduce the costs of the solar electricity, reflectors have been placed in the construction to focus the radiation onto the solar cells. In this way expensive solar cells can be replaced by considerably cheaper reflector material. The tiltable reflectors give the user a possibility to control the amount of radiation being transmitted into the building. The reflectors can also be used to reduce the thermal losses through the window.

A model for electric and hot water production was developed. The simulation program, in Excel, can perform yearly energy simulations where different effects such as shading of the cells or the glazing effects can be included or excluded. The simulation can be run with the reflectors in an active, up right, position or with the reflectors in a passive, horizontal, position. The simulation program was calibrated against a prototype window placed in Lund in the south of Sweden and against the solar window in Solgården. The calculation model serves as a basis for the module written for the simulation program TRNSYS. A “TRNSYS-deck” was built and calibrated for the building Solgården.

Yearly simulations of the energy balance for a house with the solar window was compared to simulations where the 16m² solar window was replaced with an 8m² normal window. The results show that the annual amount of auxiliary energy is lower with a developed solar window, including low-e coating on the glazing, compared to the normal window case. The developed solar window has considerable lower U-values than the existing solar window.

Introduction

Solar electricity is today too expensive to compete with regular grid electricity. One technique to reduce the price per kWh for the solar electricity is to use reflector material to focus light onto the PV cells. Since the reflectors are considerably cheaper compared to the PV cells the price per kWh can be reduced. Further price reduction is possible if the solar modules can be build into the house construction and thus saving frames and glazing of the module, alternatively roofing materials etc. can be replaced by solar modules. Since the efficiency of the PV cells decreases with high temperature there is also a need to keep the cells as cold as possible. Active cooling on the back of the cells gives both cool PV cells and hot water for domestic use.

The solar window [Fieber 2005] seen in figure 1 below benefits from all of these advantages. Apart from the stated benefits with a solar window there are also thermal advantages. Using an efficient control mechanism to control the tiltable reflectors gives the possibility to control the amount of radiation transmitted into the building. During the summer the reflectors can be put in a vertical position to block the sun and during the winter the reflectors can be tilted to a horizontal position to allow passive heating of the building.

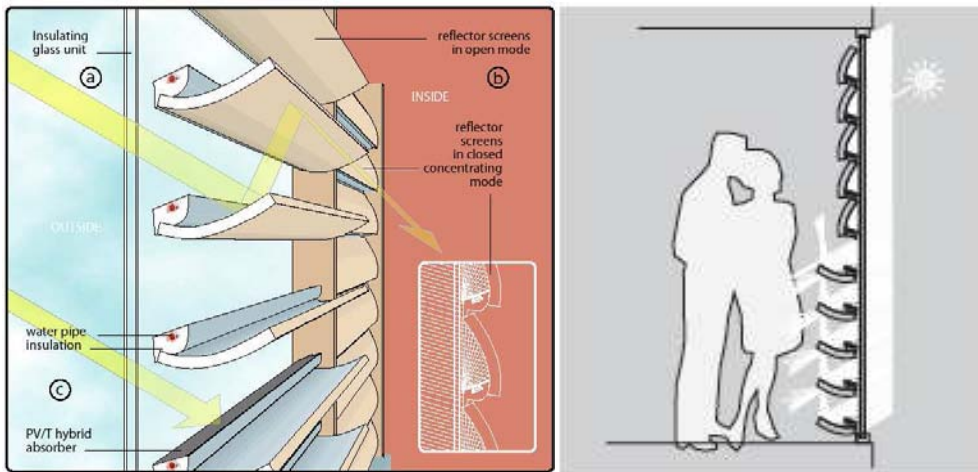

Figure 1. The solar window lets light into the building when the reflectors are folded backwards. If the reflectors are closed there is no light let through the window.

The building, Solgården [Larsson 2005] in figure 2, where the solar window has been installed is constructed by prefabricated Expanded PolyStyrene, EPS-blocks [Hellgren]. The walls are a sandwich construction made of, from the outside, stucco or wooden panel, EPS, plywood and gypsum. The building is airtight to allow the heat recovery unit to function fully. The total window area of the building is 30.2 m² of which 20 m² is directed to the south side. The south direction gives high output for the solar window and a high passive solar fraction. The reflector gives the required sun shade during the summer. The lack of heavy elements in the outer walls is compensated with heavy internal walls. The cardiac wall made of bricks and the concrete slab works as heat storage to even out the temperature differences between night time and day time. A sketch of the building blocks can be seen in figure 3 below. The numbered parts in figure 3 are the different components making up the building skin.



Figure 2. The low energy house Solgården in Älvkarleö, Sweden.

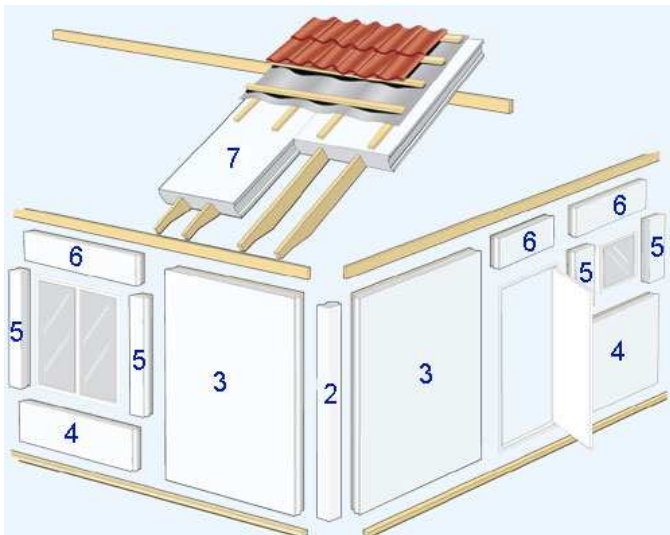

Figure 3. Building technique for Solgård.

The energy system for Solgård is shown in figure 4. It is build up around a 620 l large Bio-Sol-Panna from Stocksbroverken [Stocksbro]. A pellet burner placed on the tank supplies heat to the building during periods of low radiation. The hot water produced in the solar window is exchanged in the storage tank, and the electricity produced is stored in the battery bank of approximately 10 kWh. All the household appliances are as electrically efficient as possible, including low energy lightening.

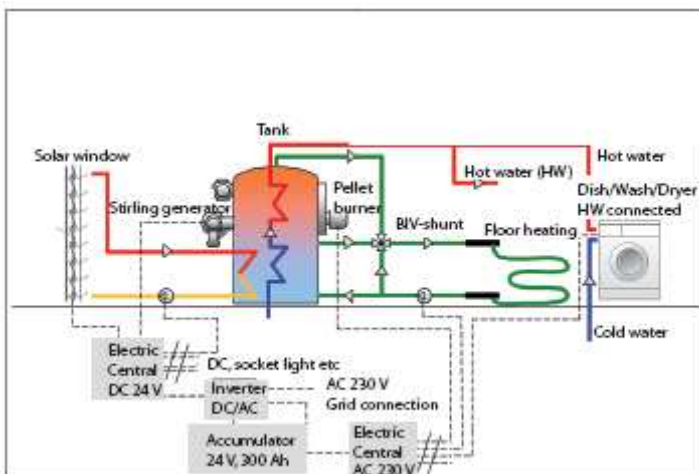

Figure 4. The energy system of Solgård.

The model

A prototype of the solar window was evaluated during 2006 in Lund. The prototype consists of five series connected absorbers with foldable reflectors. The top absorber is laminated with PV cells of a size of 62.5 mm*125 mm. The geometric concentration factor, i.e. relation between glazed area and absorber area is 2.45. The optical axis of the parabolic reflectors is directed 15° above the horizon with focus on the front edge of the absorber. This means that radiation that impinges on the reflector from angulars above 15° over the horizon is reflected onto the absorber, light below 15° is reflected out. An antireflective double glass is placed in front of the absorbers. The prototype, build into an EPS box can be seen in figure 5.

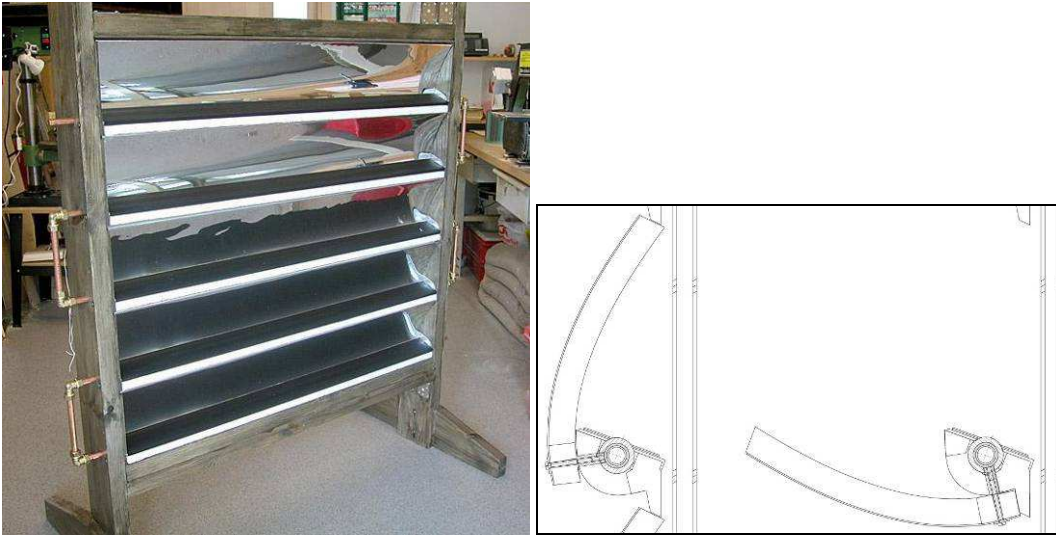

Figure 5. The prototype of the solar window. To the right is a sketch showing how the reflectors can be tilted up or down.

A CR10 Campbell logger was used to collect data consisting of global and diffuse radiation, temperature in and out of the window, the ambient temperature and the water flow through the window. The temperature measurement used a PT100 sensor. The current and the voltage generated by the PV cells was measured and collected in a CR1000 Campbell logger.

The mathematical model that was constructed calculates the amount of heat and electricity produced in the window. It also calculates the fraction of the thermal losses that are radiated into the room and the fraction that is lost to the outside. In order to carry out the calculation the radiation was divided in three parts. One part that hits the absorber directly, P_{direct} , one part that hits the reflector before hitting the absorber, $P_{\text{reflector}}$, and one diffuse part, P_{diffuse} . The calculation for the hot water production was calculated in a similar way, adding a part to the equation to model the thermal losses. Mathematically the equations can be written as below. See figure 6 for explanation.

- $P_{\text{direct}} = I_b * T_{\text{glass}}(\Theta_1) * \alpha_{\text{pv}}(\Theta_2) * f_{\text{shading}}(\Theta_3) * A_{\text{cell}} * \eta_{\text{pv}} * \cos(\Theta_2)$ (1)
- $P_{\text{reflector}} = I_b * f_{\text{glass}}(\Theta_1) * \alpha_{\text{pv}}(\Theta_4) * f_{\text{reflector}}(\Theta_5) * A_{\text{reflector}} * \eta_{\text{pv}} * R_{\text{reflector}} * \cos(\Theta_5)$ (2)
- $P_{\text{diffuse}} = I_{\text{diffuse}} * C$ (3)
- $P_{\text{total}} = P_{\text{direct}} + P_{\text{reflector}} + P_{\text{diffuse}}$ (4)

Where I_b and I_{diffuse} are the beam radiation and the diffuse radiation against the window. T_{glass} is a function that describes the transmission through the glazing as a function of the angle of incidence, α_{pv} describes the angular dependence of the absorption of the PV cells, and f_{shading} describes the shading of the PV cells caused by the window frame. $f_{\text{reflector}}$ is a correction factor for the shadow effects for the radiation which is reflected. This function includes the shading of the reflector. The angles Θ_1 to Θ_5 are different incidence angles for the beam towards the components of the solar window. A_{cell} and $A_{\text{reflector}}$ are the areas of the PV cell and the reflector respectively. η_{pv} and $R_{\text{reflector}}$ are the efficiency of the solar cells and the reflectance of the reflector. C is a response function for the diffuse light. P_{total} is the total power delivered by the window.

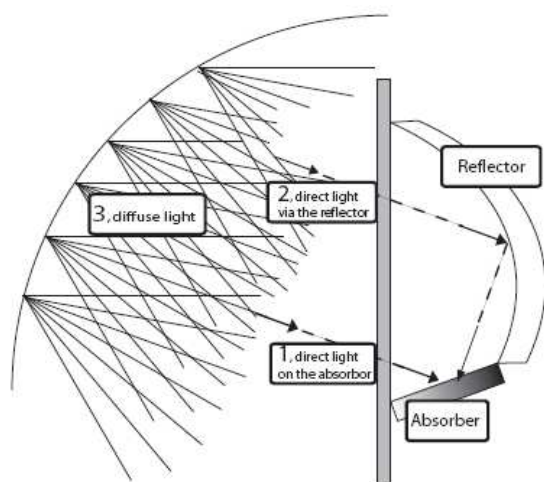

Figure 6. The radiation on the glazing was divided into three parts. Part 1 is the radiation hitting the absorber, part 2 is the direct radiation that goes via the reflector and part 3 is the diffuse radiation.

The angular dependence of the PV cells was measured and a polynomial was adjusted to fit the experiment. The angular dependence of the glazing and the shading of the PV cells were calculated theoretically. All of the limiting factors were adjusted to polynomials for easy computation.

A validation of the model can be seen in figure 7 below. The three different days were chosen to illustrate different situations. The blue graph is a simulation from the 6:th of August with the reflector in vertical, active, position. The simulation and the measurement are in good agreement apart from a few points. The discrepancy is due to usage of two different loggers for monitoring the IV-characteristics and the irradiation. Since the two clocks of the loggers were unsynchronized problems could arise in cloudy conditions. If the IV-curve was measured at a cloudless moment and the irradiance was measured during a cloudy moment the result from the simulation differ from the measurement. The measurement made the 3:rd of November with the reflector in a vertical position and the measurement made the 25:th of August with the reflectors in a horizontal, passive, position both show good correlation to simulations. Both days were chosen because of clear weather.

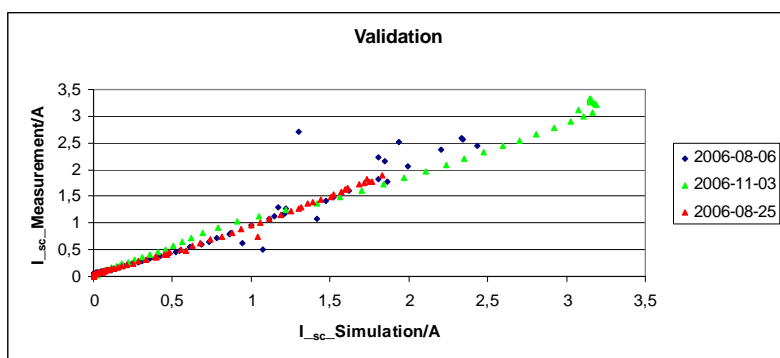

Figure 7. Correlation between measurements on the y-axis and simulations on the x-axis. The measurements 2006-08-06 and 2006-11-03 are both with the reflector in a vertical, active, position and the measurement 2006-08-25 is with the reflector in a horizontal, inactive, position.

Results of solar window component simulations

Yearly simulations were made for the solar window and for two simulated flat PV-modules. The PV-modules were simulated in the same way as the solar window but without shading and reflector. Both simulations with the PV-modules were made with 20° incline to the horizontal. The first simulation was made with the module on a wall and the second was made with the module on a roof. When located on a roof at a low tilt the diffuse radiation is larger compared to a module on a wall due to the fact that the module can see a larger part of the

sky. The result is shown in figure 8 below. All of the three simulations use the same glazing. The increase of power from the direct radiation hitting the absorber is due to less shading of the PV modules compared to the solar window. Note that the increase of the diffuse radiation from the roof mounted module almost compensates the reflector contribution in the solar window.

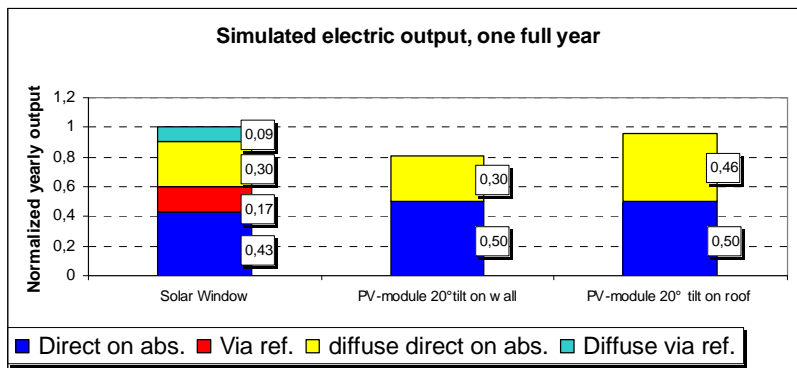

Figure 8. Simulated yearly electrical output for the solar window and a module in 20° tilt on a wall and on a roof. The blue part shows the power that comes from the direct radiation that hits the absorber without first hitting the reflector. The red part shows the direct radiation that hits the reflector before hitting the absorber. In yellow is the diffuse contribution and the light blue is the diffuse contribution that goes via the reflector before hitting the absorber.

To study the limiting factors in the solar window a simulation was carried out where the factors $f_{\text{glass}}(\Theta_1)$, $f_{\text{pv}}(\Theta_2)$ and $f_{\text{shading}}(\Theta_3)$ in equation 1 was set to 1. The simulation result shown in figure 9 below only contains the direct radiation. The reflector was put in a horizontal, inactive position. Since the angular dependence of the PV cells is large only for high angles the impact of setting $f_{\text{pv}}(\Theta_2)$ to 1 will be small, the shading is already apparent for high solar angles. If the shading effects can be removed completely the yearly output would increase by about 12% and if the glazing is omitted the increase would be as much as 19%. This clearly shows the importance of choosing the best glazing and not placing the PV cells in such a position where the shading is too large. It might even be better to have one cell less if the shading caused by the window frame on the outer cells is large.

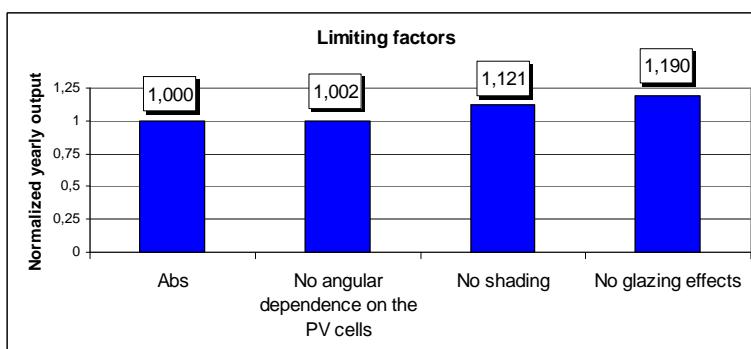

Figure 9. The different limiting effects on the solar window are subsequently removed and the yearly electrical output is simulated.

Result, TRNSYS system simulations

A TRNSYS deck was developed to simulate the window in a realistic environment. A simplified version of the deck can be seen in figure 10. The deck was calibrated against collected data. The weather data used was for Gävle, 20 km east of Älvkarleö.

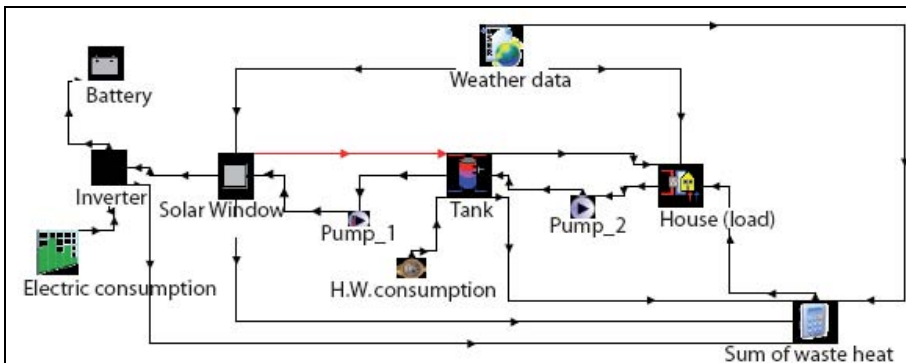

Figure 10. A simple survey of the TRNSYS-deck. To make the figure more clear the connections, printers etc. was removed from the deck.

Simulations were carried out for one full year. The yearly distribution of the solar energy produced in the solar window can be seen in figure 11 below. Since solar heating has thermal losses there is a minimum of irradiation required before the pump starts and heat can be delivered to the storage tank. PV cells however, deliver a fraction of electric energy whether the irradiation is low or high. This results in an equally large energy production during the winter for hot water and electric energy. During the summer the thermal energy delivered is about seven times larger compared to the delivered electric energy. Figure 11 also shows the constant energy production between May and August. This is due to the high angle of inclination for the solar window. If a lower angle is used the total annual production would be larger but with a much higher fraction during the summer. The risk of boiling of the water in the tank increases with lower inclinations. The high angle of inclination is compensated with a larger window. In this way a large fraction of the domestic hot water is obtained by solar power even during the spring and the autumn.

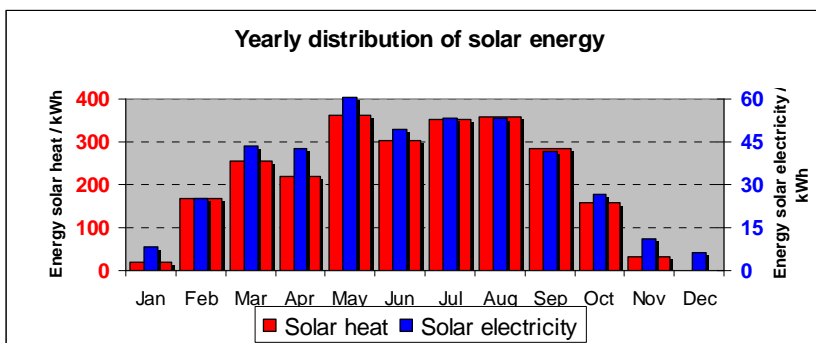

Figure 11. Annual distribution of solar energy. The solar heat is in red and the solar electricity is in blue, the right y-axis. and $1.3 \text{ W/m}^2\text{K}$ if the reflectors are closed and the normal window was assumed to have a U-value of $1.1 \text{ W/m}^2\text{K}$. The normal window was chosen to be 8 m^2 to model a conventional south facade. To optimize the electric output of the solar window the glazing is anti reflection treated and does not have any radiation blocking low emittans coatings, which tend to decrease the transmittance. This is the one of the reasons for the relatively high U-value of the solar window. A simulation was also performed for a case where a low emittans coating was put on the glazing. Choosing a coating material with a high transmittance such as SnO_2 the electric energy production will only be affected marginally. The heat losses will however be suppressed. The simulation was made where the U-value was assumed to decrease to $1.5 \text{ W/m}^2\text{K}$ for the open mode and to $0.6 \text{ W/m}^2\text{K}$ for the closed mode. The transmitted radiation was assumed to reduce by 12% due to the low emittans coating. These simulations can be seen in figure 12 below. The normal window case is marked "Reference" in the figure. The results show that the developed window saves 1400 kWh compared to the reference window.

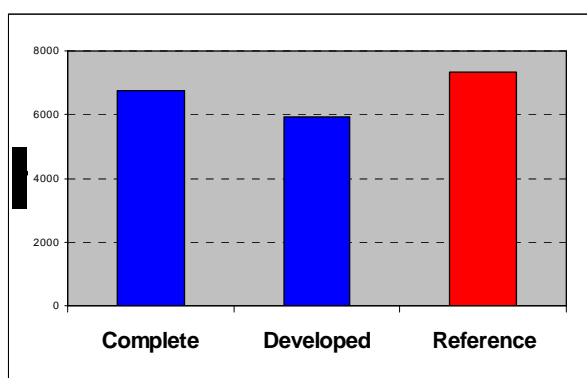

Figure 12. Simulated energy need for the complete solar window compared to a developed and a reference window. The low emittans coated window is marked developed in the figure.

Discussion and conclusion

The developed simulation model shows to be in good agreement with measured data. The developed solar window was also compared to a case with the reference window including a 5 m² solar collector and a 4 m² PV module, both placed on the roof of the house. In order to have a distribution of the hot water production that is similar to the production of the solar window, a tilt of 80° was chosen. The result from the simulation is shown in figure 13. The reference case including the solar collector and the PV module needs about 1000 kWh less auxiliary compared to the house with the developed solar window. The reason for this is that a normal window can be used for passive heating of the building at the same time as thermal heat is being produced in the solar collector placed on the roof. This is not possible for the solar window where the utilized passive heating competes with the hot water and electric production. Opening the reflectors, putting them in a passive position, means not only passive heating but also low hot water production and high U-value of the window. Closing the reflectors means not only low U-value for the window and high hot water production, but also no passive heating for the building. The simulation for the reference case is however slightly optimistic since no solar shading was used. This will definitely be required to avoid over heating of the building. Solar shading will decrease the passive heating and thus lead to a larger auxiliary need. A well designed solar protection can however minimize this effect.

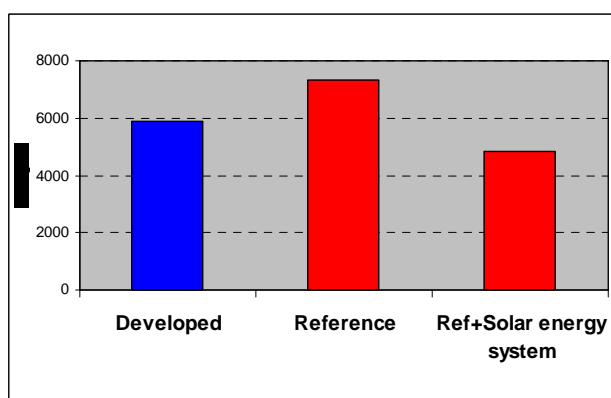

Figure 13. Simulated energy need for the developed window compared to a reference window and a reference window including a solar collector and a PV module placed on the roof of the building.

References

- Fieber, Andreas, Building Integration of Solar Energy, A Multifunction Approach, report EBD-T—05/3 (2005)
 Larsson, Stefan, Bygg snålt med egen energi, ISBN 9173331031 (2005)
 Hellgren www.davidhellgren.se
 Stocksbro www.stocksbro.se

Forenklet og kostnadseffektiv vannbåren varme skreddersydd til passivhus-leiligheter

Tor Helge Dokka, SINTEF Byggforsk, 7465 Trondheim, Norge
Leif Amdahl, Norsk VVS forening, Postboks 2843 Tøyen, 0608 OSLO

Problemstilling

I flere større leilighetsprosjekter de siste årene har det blitt en konflikt mellom det å bygge lavenergiboliger eller passivhus, og samtidig ha et vannbårent oppvarmingsanlegg [Thyholt 2006]. Utbyggere og entreprenører framholder ofte at ekstrakostnadene ved bygge med lavt varmebehov samtidig med å benytte vannbårene oppvarmingsanlegg ikke er regningssvarende.

I en passivhus-leilighet med meget lavt og variabelt varmebehov vil også et konvensjonelt vannbårent varmeanlegg, for eksempel med gulvvarme i de fleste gulv, være meget vanskelig å regulere nøyaktig. Treghten i et gulvvarmesystem vil kunne føre til periodevis overoppvarming, og lite energieffektiv drift. Gulvvarme i leiligheter der det er lite isolasjon under varmesjiktet, slik det ofte er i etasjeskillere i leiligheter, vil også kunne føre til at mye av varmen tilføres leilighetene under, med tilhørende dårlig systemvirkingsgrad for varmeanlegget. Ved bruk av vannbårene radiatorer unngår man mye av disse ulempene.



Figur 1: Konvensjonell vannbåren gulvvarme i oppholdsrom, brukes i mange leilighetsprosjekter i dag.

Forutsetning for forenkling av varmesystem

Det er mulig med en betydelig forenkling av varmeanlegget i leilighetsprosjekter, men dette forutsetter en rekke tiltak på klimaskjermen og ventilasjonsanlegget:

- Balansert ventilasjon med temperert innblåsning (ikke lavere enn 15-16 °C). Avtrekksventilasjon eller naturlig ventilasjon der kald uteluft trekkes inn gjennom ventiler i klimaskjermen vil kreve distribuerte oppvarmingsenheter i de fleste rom for å oppnå god komfort. Varmetapet ved avtrekks- eller naturlig ventilasjon fører også til et stort varmetap som må kompenseres med betydelig oppvarmningseffekt.
- Kraftig reduksjon av infiltrasjon (luftlekkasjer) gjennom utettheter i klimaskjermen. Infiltrasjon kan både føre til trekkproblemer og et betydelig forhøyet oppvarmingsbehov, som begge er uforenelig med forenkling av oppvarmingsanlegget.
- Redusert transmisjon- og kuldebrotap. Det er meget viktig at ytterkonstruksjoner (vegg, gulv, tak) er meget godt isolert, og at kuldebroer er tilnærmet eliminert. Dette vil gi høye overflatetemperaturer (ingen kalde gulv) som er en forutsetning for å unngå distribuerte oppvarmingsenheter i hvert rom, og ved yttervegg (perimeteroppvarming).
- Superisolerte vinduer, glassfelt og balkongdører. Et vanlig komfortproblem i mange boliger er kaldras fra vinduer og store glassflater. Dette kan unngås ved å plassere oppvarmingsenheter under vinduer/glassflater (konvensjonell løsning), eller ved å bruke veldig godt isolerte vinduer/glassflater.



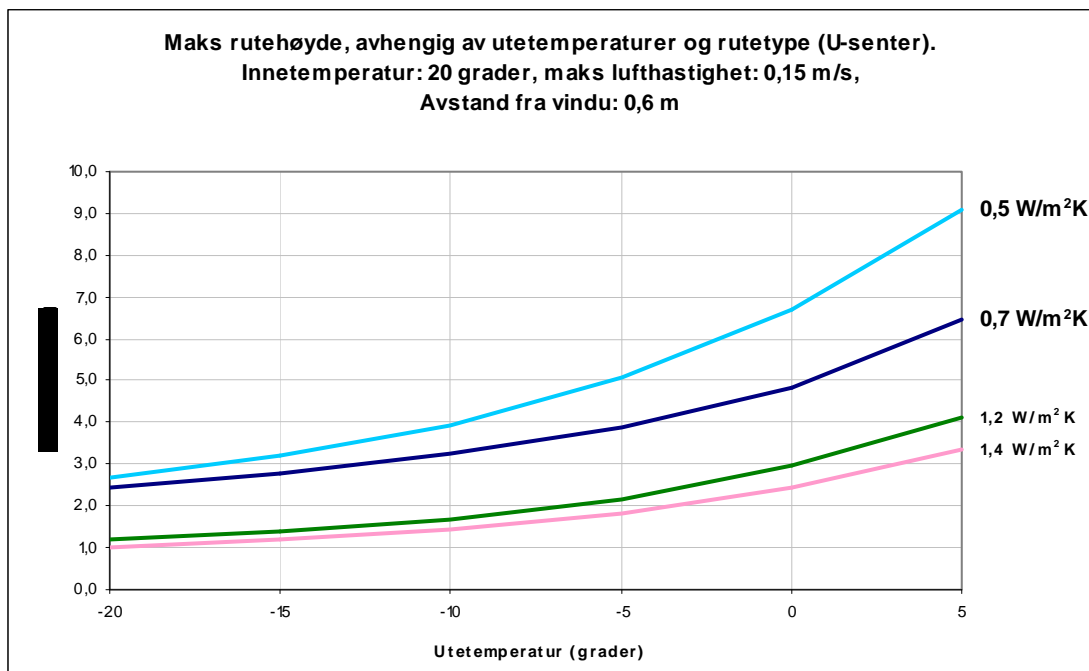

Ved forenkling av varmeanlegget, er man derfor nødt til å bruke godt isolerte glassflater. Figur 2 angir maksimal høyde på vindusrute som funksjon av U-verdi på rute og utetemperatur, for å unngå kaldrasproblemer (over 0.15 m/s).

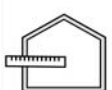

Figur 2: Maksimal høyde på vindusrute/glassflate som funksjon av U-verdi rute og utetemperaturen. Basert på [Heiselberg 1994]. Figur: Marit Thyholt.

Samlet gir dette overflatetemperaturen nære lufttemperaturen, ingen kaldrasproblemer og ingen trekkproblemer pga. infiltrasjon og ventilasjon. I tillegg fører det til en jevn temperatur i hele leiligheten, selv uten oppvarmingsenheter i hvert rom. Tabell 1 angir anbefalte spesifikasjoner for å kunne forenkle varmeanlegget. Ved å bygge etter passivhus-spesifikasjoner [Andresen 2008] vil spesifikasjonene i tabell 1 være automatisk oppfylt.

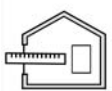
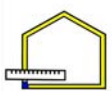
Tabell 1: Anbefalte krav for å kunne forenkle varmesystemet i leilighetsprosjekter.

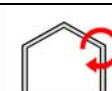
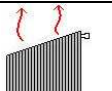
	Spesifikasjon	Krav
	Maksimal U-verdi yttervegg og yttertak	0.15 W/m ² K
	Maksimal U-verdi gulv	0.12 W/m ² K
	Maksimal U-verdi vinduer Maksimal U-verdi glassrute (midtfelt)	0.90 W/m ² K 0.60 W/m ² K
	Normert kuldebroverdi ihht. NS3031 Maksimal lineær kuldebroverdi	0.02 W/m ² K 0.05 W/mK
	Luftlekkasjer, maksimalt lekkasjetall ved 50 Pa.	0.60 oms/t
	Balansert ventilasjon, minimum innblåsningstemperatur	15 °C
	Oppvarmingsbehov, maksimalt effektbehov	15 W/m ²

Forenklet varmesystem

Radiator som dekker varmebehovet

Med tiltak som beskrevet over der man kan unngå oppvarmingsenheter i hvert rom, og også under vinduer eller i perimetersoner (langs yttervegg), har man mulighet til å dekke hele varmebehovet i leiligheten med en sentral plassert radiator. Dette vil være tilstrekkelig for leiligheter opp til 90-100 m² på et plan. For større leiligheter eller leiligheter over flere plan, kan man fortsatt gjøre betydelige forenklinger, men man må trolig ha flere radiatorer.

Komfortvarme på bad

I de aller fleste norske leilighetsprosjekter er det et komfortkrav med gulvarme på bad. I mange leilighetsprosjekter som har vannbåren varme, blir det allikevel brukt elektriske varmekabler for å unngå å ha to temperaturnivåer: et for gulvvarme i bad (30 -35 °C) og et for radiatorsystemet (60-90 °C). Med nye gulvvarmerør som nå er på markedet (se figur 3) er det mulig å bruke samme temperaturnivå (60-65 °C) på både radiator og gulvvarme, og dermed forenkle varmesystemet. Disse varmerørene er *litt* isolert slik at overflatetemperaturen på baderomsgulvet blir den samme selv med turtemperatur på 60-65 °C, som om man brukte vanlig gulvvarmerør (type PEX) med turtemperaturer på 30-35 °C.



Figur 3: Gulvvarmerør med isolerende kappe som kan brukes med turtemperatur opp til 70 °C. Bilde: www.rotex.com.au.

En naturlig plassering av radiator er da på utsiden av baderomsvegg, mot stue eller entre (som er åpen mot stue/andre oppholdsrom), se figur 4. Dette gir et enkelt, kompakt og meget kostnadseffektivt varmeanlegg med meget korte rørstrekk. Med et temperaturnivå på 60-70 °C som er vanlig temperaturnivå for varmt tappevann, er det også mulig å bruke en enkeltmantlet bereder som illustrert i figur 4. Dette gir ytterligere en besparelse, da man kan bruke samme temperaturnivå på både radiator, gulvvarme og varmt tappevann. Et annet viktig grep for å bringe kostnadene ned ved slike løsninger, er å redusere antall komponenter som bygges inn i anlegget. En kommer fort dit at det ene drar det andre med seg. Eksempelvis nevnes ekspansjonssystemet. Dersom man velger lukket ekspansjonskar, må det installeres sikkerhetsventiler, i tillegg til selve karet. Videre må systemet tilknyttes vannledningsnettet for oppfylling og etterfylling. Dette krever sluseventil og kikkran. Hver for seg små beløp, men i sum nok til å forrykke økonomien i løsningen.

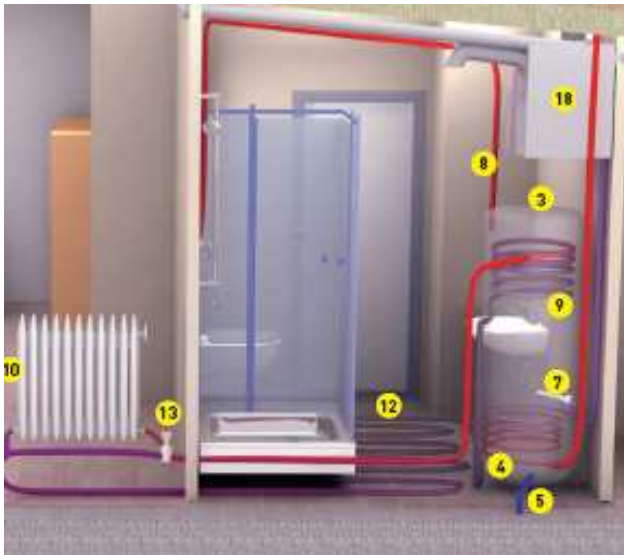

Figur 4: Viser radiator og gulvvarme, sammenkoblet i samme varmesløyfe, med plassering av radiator på yttersiden av baderomsvegg mot stue. Illustrasjon: Tor Åsmund Evjen.

Løsning i Løvåshagen prosjektet

I forbindelse med leilighetsprosjektet Løvåshagen i Bergen med 28 passivhus-leiligheter [Dokka 2008] er det anvendt en ny type vannbårent oppvarmingsanlegg basert på tankegangen beskrevet over. Anlegget er skreddersydd det lave oppvarmingsbehovet i leilighetene.

På grunn av meget godt isolerte konstruksjoner, superisolerte vinduer, og eliminerte kuldebroer og luftlekkasjer, er det ikke behov for oppvarmingskilder under vinduer eller på yttervegger.

For passivhusene i Løvåshagen er det derfor tilpasset et kompakt vannbårent anlegg med vannbåren gulvvarme på bad og en radiator på yttersiden av baderomsveggen (vender mot entre/stue). Radiatoren er dimensjonert slik at den dekker varmebehovet i alle andre rom i leiligheten, og har en installert effekt på mellom 900 og 1300 W. Gulvvarmesløyfen og radiatorsløyfen er koblet i serie (ett rørs-system), og har samme temperaturnivå (55-60 °C) for å forenkle systemet. For å unngå høye overflatetemperaturer på badegulvet benyttes en isolert type vannrør i baderomsgulvet. Både radiator og baderomsvarme styres av termostatventiler. En optimalisert

akkumulator/bereder på 300 liter, som plasseres på bad i hver leilighet, er også utviklet for prosjektet. Denne maksimerer energiopptak fra solfangere på tak, samt gir optimal drift av det vannbårne oppvarmingsanlegget.

Det vannbårne oppvarmingssystemet er kostnadsberegnet til å være kun litt dyrere enn et elektrisk oppvarmingssystem med panelovn og elektriske varmekabler.

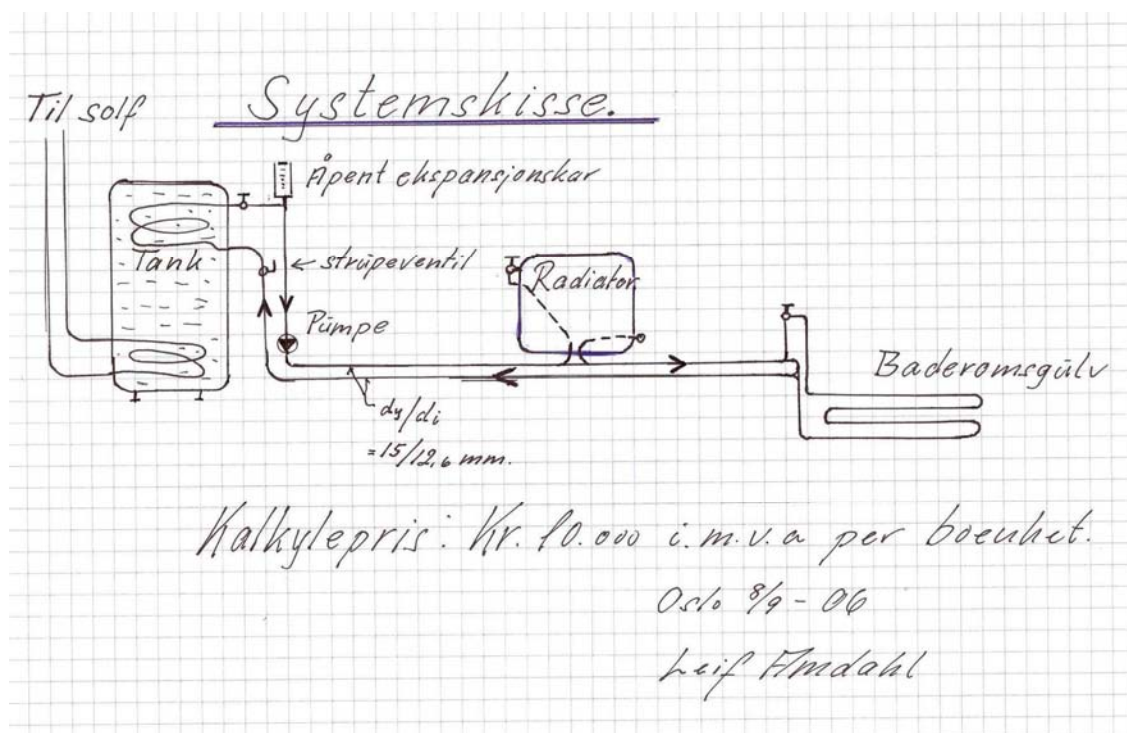

Figur 5: Systemskisse av varmesystemet i Løvåshagen-prosjektet. Illustrasjon: Leif Amdahl.

Referanser

- [Thyholt 2006] Thyholt, M. (2006), Varmeforsyning til lavenergiboliger i områder med fjernvarmekonsesjon. Analyser av CO₂-utslipp og forsyningssikkerhet for elektrisitet. PhD-avhandling, NTNU
- [Heiselberg 1994] Heiselberg P., "Draught risk from cold vertical surfaces", Building and Environment, 29, pp. 297 – 301, 1994
- [Andresen 2008] Andresen I, Dokka TH, Lexow T, "New Norwegian Standard for Low Energy and Passive Houses" Paper Passivhus Norden 2008, Trondheim.
- [Dokka 2008] Dokka TH, Helland K, "Løvåshagen: Norges første lavblokkprosjekt med passivhusstandard", Paper Passivhus Norden 2008, Trondheim

High-Efficiency Heat Pump Water Heater System for Apartment Buildings of Passive House Standard

J. Stene

SINTEF Energy Research, Department of Energy Processes
Kolbjørn Hejes vei 1D, 7465 Trondheim, Norway
jorn.stene@sintef.no

T. Hjerkin

Multiconsult AS, Section Thermal Systems
Nesttunbrekka 95, 5221 Nesstun, Norway
tore.hjerkin@multiconsult.no

“Bergen og Omegn Boligbyggelag” is about to construct a number of apartment buildings of passive house standard at Damsgårdssundet in Bergen, Norway. The total energy demand for domestic hot water (DHW) heating for one of the buildings with 40 flats has been estimated to be 170,000 kWh/year, i.e. 4,250 kWh/flat. In passive houses the annual energy demand for heating of DHW typically constitutes 70 to 85% of the total annual heating demand of the building. It was therefore regarded as interesting to carry out an in-depth study of a centralized heat pump water heater system.

Four different heat pump designs were simulated in order to find the maximum theoretical coefficient of performance (COP). The simulations showed that a heat pump water heater using carbon dioxide (CO₂, R744) as working fluid will achieve about 20% higher COP than high-efficiency state-of-the-art heat pump systems using R134a or R290 (propane) as working fluid. CO₂ is also a non-flammable and non-toxic fluid that does not contribute to global warming as the HFC working fluids.

An in-depth analysis was carried out for a 26 kW CO₂ heat pump water heater system. Four different heat sources were evaluated, including ambient air, sea water, ground water and grey water (waste water). The CO₂ heat pump unit was simulated with CSIM, which is an advanced simulation tool for design and optimization of CO₂ heat pump and air conditioning systems. The calculated COP for a CO₂ heat pump water heater using 7°C groundwater as heat source was about 3.8 when supplying 70°C hot water. This corresponds to a *net energy saving of about 70-75%* compared to state-of-the-art electric immersion heaters in single-shell hot water tanks.

The calculated maximum allowable investment cost for the CO₂ heat pump water heater system was about €125,000 when assuming an average COP of 3.5, 6% real interest rate, 15 years system lifetime and an electricity price of approx. 0.1 €/kWh. Due to the high energy efficiency, the excellent profitability and the favourable environmental properties of CO₂, CO₂ heat pump water heaters are regarded as a very promising alternative for centralized hot water heating in apartment buildings and block of flats of low-energy and passive house standard. Air-to-water CO₂ heat pump water heaters in the capacity range from about 5 to 30 kW are now available from several Japanese manufacturers.

1. Domestic Hot Water Demand in Apartment Buildings

“Bergen og Omegn Boligbyggelag” is about to construct a number of apartment buildings of passive house standard at Damsgårdssundet in Bergen, Norway with about 300 flats. An in-depth analysis has been carried out for one of the buildings with 40 flats in order to develop the most energy efficient design for a centralized heat pump water heater (HPWH) system.

Figure 1 shows a sketch of the 2nd floor of the apartment building has been analyzed (Hjerkin, 2007).

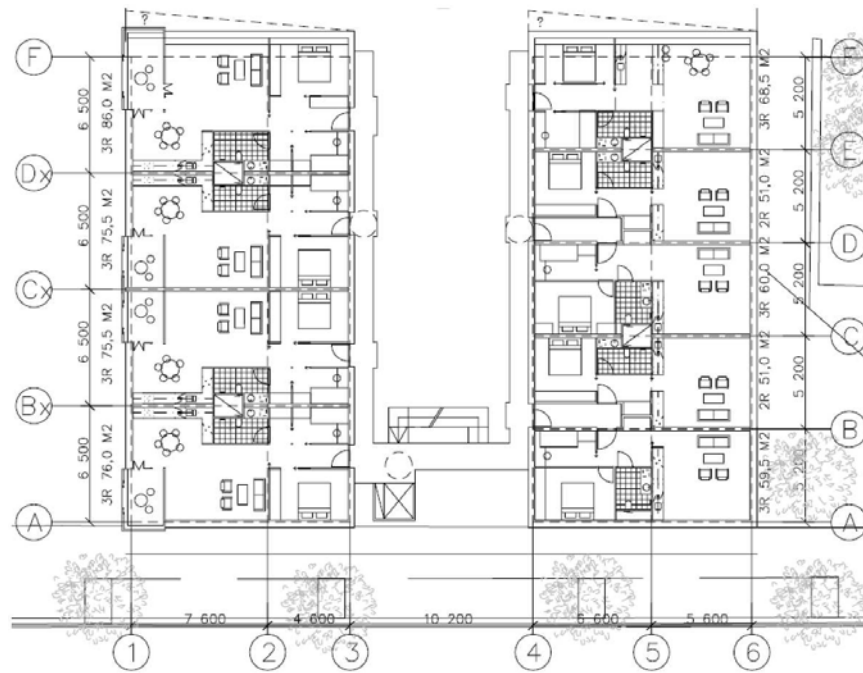

Figure 1 Sketch of the 2nd floor of the apartment building [Hjerkinn, 2007].

Domestic hot water (DHW) is normally used for washbasins, bath-tubs, showers, washing up, cleaning etc. If an energy efficient heat pump is being used for DHW production, DHW can be supplied to washing/dish-washing machines and thereby reduce the electricity demand for the building.

The energy demand for heating of DHW was estimated to be approx. *170,000 kWh/year*, i.e. about 12 kWh per 24 hours and 4,220 kWh/year for each flat. The calculated annual energy demand for heating of DHW (*E*) was based on Eq. 1.1, where *p* is the number of residents for each flat (in average 2 persons), and 620 kWh/year is the total annual DHW heating demand for one washing machine and one dish-washing machine [Hjerkinn, 2007].

$$E = [4,300 + 700 \cdot (p - 3) + 620] \text{ kWh/year} = [4,300 - 700 + 620] = 4,220 \text{ kWh/year} \quad (1.1)$$

The required heating capacity for the HPWH was estimated to be 26 kW. The capacity was calculated assuming 18 hours operating period per 24 hours for the heat pump unit and the application of DHW storage tanks to cover large momentary DHW demands. The city water temperature and the average DHW temperature at the tapping sites was 5°C and 45°C, respectively.

Based on 26 kW heating capacity for the HPWH (*E*) and a minimum and a maximum DHW storage temperature of 55 and 70°C, respectively, the total volume for the DHW storage tanks was calculated using Eq. 1.2. *Q* is the maximum DHW energy demand over an estimated period of 2.8 hours (*t*) and *a* is the calculated accumulation factor for the DHW storage tanks (Hjerkinn, 2007).

$$V = \left(\frac{Q - E \cdot t}{a} \right) = \frac{300 \text{ kWh} - (26 \text{ kW} \cdot 2.8 \text{ h})}{0.06 \text{ kWh/l}} \approx 3,800 \text{ litres} \quad (1.2)$$

Figure 2 shows the 24 hour DHW consumption diagram for the apartment building, with the maximum DHW demand between 16-19 o'clock in the evening (approx. 3 hours maximum, ref. Eq. 1.2).

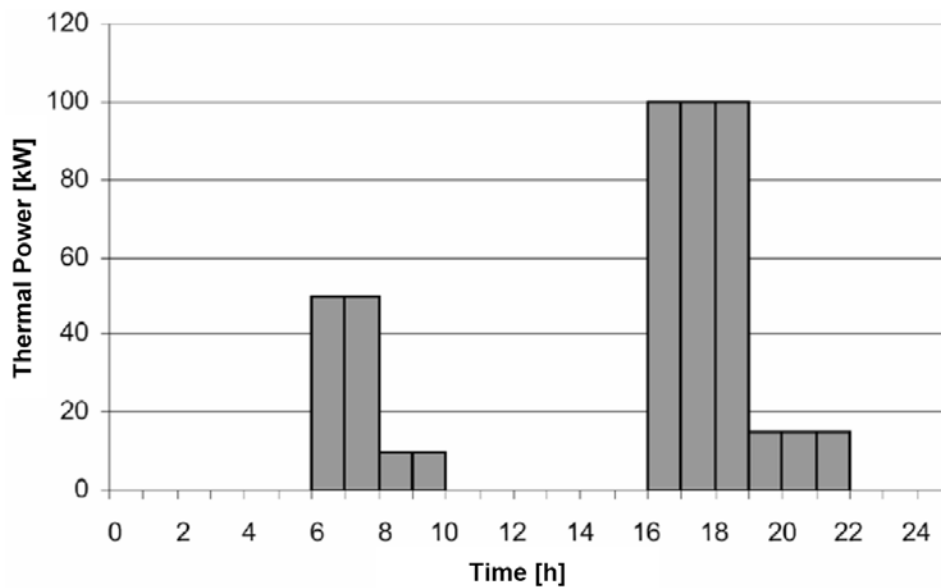

Figure 2 24 hours DHW consumption diagram for the apartment building [Hjerkin, 2007].

2. Evaluation of Different Heat Pump Water Heater Systems

2.1 Heat Exchanger Design and Configuration

Four different heat pump water heater (HPWH) systems were simulated and optimized in order to determine the maximum Coefficient of Performance (COP²) at varying evaporation temperature (-10 to +10°C), varying inlet water temperature (5 to 30°C) and varying outlet water temperature (60 to 85°C). The HPWH units were as follows:

- System 1 – Heat pump with condenser and desuperheater
- System 2 – Heat pump with condenser, desuperheater and subcooler
- System 3 – Heat pump with condenser, desuperheater and suction gas heat exchanger
- System 4 – CO₂ heat pump with a single gas cooler

Heat pumps for low- and medium-temperature space heating reject heat in a single condenser by condensation of the working fluid at virtually constant temperature and pressure. In order to enable production of DHW in the required temperature range (60-80°C) and still achieve a relatively high COP for the heat pump, state-of-the-art HPWH systems are always equipped with a desuperheater and possibly a subcooler. A *desuperheater* is a heat exchanger that is cooling down the hot exhaust gas from the compressor for reheating of DHW, while a *subcooler* is a heat exchanger that is cooling down the working fluid from the condenser (condensate) for preheating of DHW. Many HPWH systems are also using a combination of a desuperheater and a *suction gas heat exchanger*. The latter heat exchanger transfers heat from the hot working fluid after the condenser (condensate) to the cold suction gas at the compressor inlet, and increases the exhaust gas temperature, the superheating enthalpy and the COP of the heat pump.

Figure 3 shows an example of a cooling curve of the working fluid and a heating curve of the water for a HPWH in a Temperature-Enthalpy diagram (T-h diagram). In this case the water is being heated from 5 to 70°C (Hjerkin, 2007).

² COP – The ratio of the heating capacity of a heat pump (Q) and the input power to the compressor (P), $COP=(Q/P)$. The higher the evaporation temperature/pressure and the lower the condensation temperature/pressure, the higher the COP.

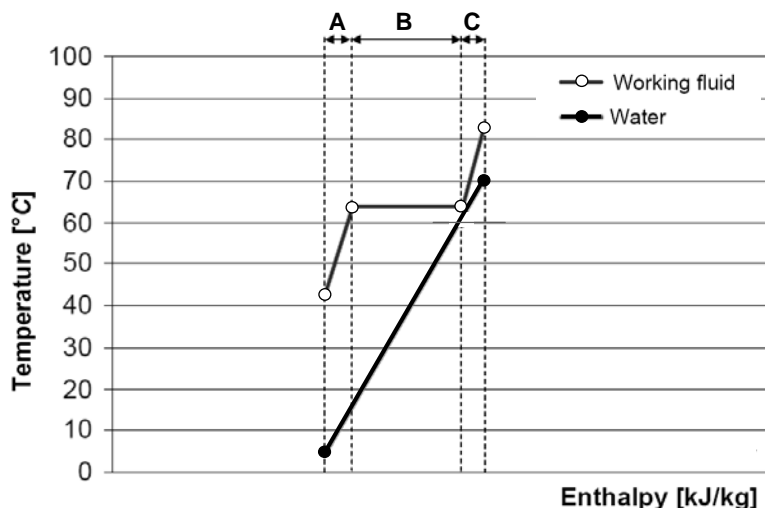

Figure 3 Sequential heat rejection in a subcooler (A), condenser (B) and desuperheater (C) in a heat pump water heater (HPWH) for heating of water from 5 to 70°C (Hjerkin, 2007).

Heat pump systems using carbon dioxide (CO₂, R744) as working fluid, represent a new and promising technology, e.g. for HPWH systems. CO₂ is a non-flammable and non-toxic fluid that does not contribute to global warming as the HFC working fluids, i.e. GWP³=0. Due to the unique thermophysical properties of CO₂, high energy efficiency can be achieved if the heat pump system is correctly designed and operated in order to utilize the properties of the fluid. Due to the low critical temperature of CO₂ (31.1°C), a CO₂ heat pump water heater will be operating in a so-called transcritical heat pump cycle where heat is rejected by cooling of CO₂ vapour at supercritical pressure in a single counter-flow gas cooler. Typical temperature profiles for CO₂ and water in a CO₂ gas cooler for hot water heating is shown in Figure 5, Chapter 2.2.

2.2 Computer Simulations and Optimization

With reference to Chapter 2.2, heat pump systems no. 1-3 were simulated with both R134a and R290 (propane) as working fluids since these fluids have a sufficiently high condensation temperature (60 to 70°C) when using components and auxiliary equipment with standard 25 bar pressure rating.

In order to attain equal boundary conditions for the four different heat pump units, the various heat exchanger combinations were simulated with equal maximum UA-values, which limited the size and heat transfer efficiency of the heat exchangers. The UA-value ranged from 1,800 to 2,400 W/K, and the higher the UA-value the lower the condensation temperature. Consequently, the highest COP was achieved when using an UA-value of 2,400 W/K.

Figure 4 shows the calculated maximum COP for the different HPWH systems as a function of the evaporation temperature, t_E (Hjerkin, 2007). In the calculations it was assumed a max. UA-value of 2,100 W/K for the condenser and gas cooler, 5 K superheated vapour from the evaporator, 5°C inlet water temperature and 70°C hot water temperature. The overall isentropic efficiencies for the compressors were calculated on the basis on typical efficiency curves from laboratory measurements.

The R744 HPWH system achieved in average 20% higher COP than the state-of-the-art units with R134a and R290 due to higher compressor efficiency and the excellent temperature fit in the gas cooler between the CO₂ and the water. The latter affected the average temperature during heat rejection and thereby the COP of the system. Figure 5 shows the heating and cooling curves for water and CO₂ at 12 and 70°C inlet and outlet water temperature, respectively (Hjerkin, 2007).

³ Global Warming Potential – GWP=0 for CO₂ when it is used as a working fluid in a heat pump.

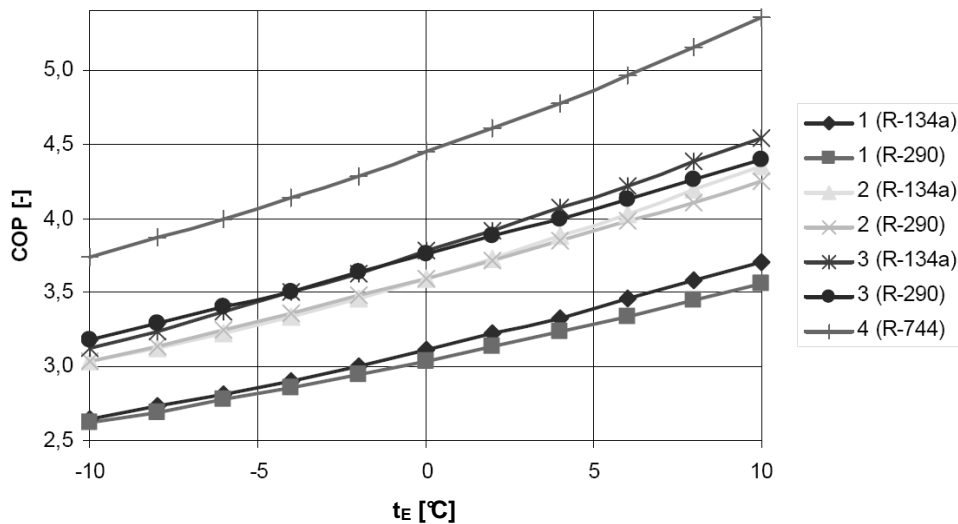

Figure 4 Calculated COP as a function of the evaporation temperature t_E (Hjerkinn, 2007).

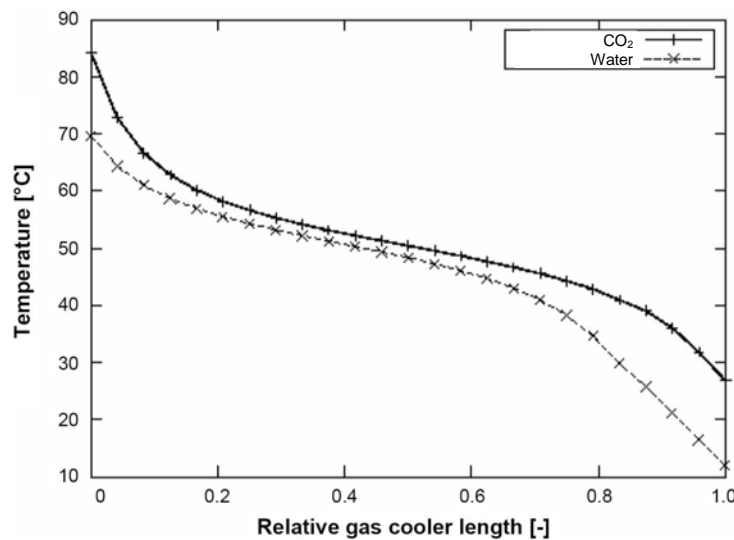

Figure 5 Calculated temperature profiles for CO_2 and water in the gas cooler (Hjerkinn, 2007).

For the state-of-the-art HPWH systems with R134a or R290 as working fluid, *System 2* (condenser, desuperheater and suction gas heat exchanger) and *System 3* (subcooler, condenser, desuperheater) achieved more or less the same COP at varying operating conditions. *System 1* (condenser and desuperheater) achieved roughly 15% lower COP than System 2 and 3. The main reason for the lower COP was that System 1 operated at a higher condensation temperature due to poorer temperature fit between the water the working fluid in the different heat exchangers.

It was decided to use the CO_2 heat pump water system for the apartment buildings in Bergen, since the heat pump achieved the highest COP, was able to cover the entire hot water demand up to 70-90°C and the fact that CO_2 represent an environmentally friendly working fluid due to its zero GWP value.

3 Design and Evaluation of a CO₂ Heat Pump Water Heater

With reference to Chapter 1, the CO₂ heat pump water heater (HPWH) was designed for 26 kW heating capacity at 12°C inlet city water temperature, 70°C DHW temperature and 3 K difference between the outlet CO₂ and the inlet city water in the gas cooler. The isentropic and volumetric efficiency of the compressor was 0.70 and 0.75, respectively (Hjerkin, 2007).

3.1 Component and System Design

The heat pump evaporator was designed for four different heat sources of current interest:

- Ambient air (DOT⁴=-10°C, t_{ave}⁵=7.8°C in Bergen)
- Seawater (indirect system design, 0°C average temperature)
- Groundwater (7°C average temperature in Bergen)
- Grey water (waste water from the apartment building, 20°C average temperature)

For ambient air the evaporator was a fin-in-tube heat exchanger with copper tubes and aluminium fins with 12 mm spacing. For seawater, groundwater and grey water the selected evaporator was a 60 bar plate heat exchanger. Furthermore, the CO₂ heat pump unit was equipped with a reciprocating compressor with 150 bar pressure rating, a 140 bar counter-flow plate heat exchanger as gas cooler, a counter-flow tube-in-tube suction gas heat exchanger, an automatic back-pressure valve (expansion valve) and a low-pressure receiver (LPR). The expansion valve and the LPR was used for optimization of the pressure in the gas cooler at varying operating conditions.

The inlet water temperature in the gas cooler has a considerable impact on the COP of a CO₂ HPWH, and the lower the temperature the higher the COP. A low inlet water temperature leads to a low CO₂ outlet temperature from the gas cooler and with that a large enthalpy difference during heat rejection. Figure 6 shows simulated relative COPs for a CO₂ HPWH unit at varying inlet water temperature and 60 and 80°C DHW temperature. By increasing the inlet water temperature from 5°C to 15 and 25°C at 60°C DHW temperature, the COP was reduced by 10 and 25%, respectively (Stene, 2004).

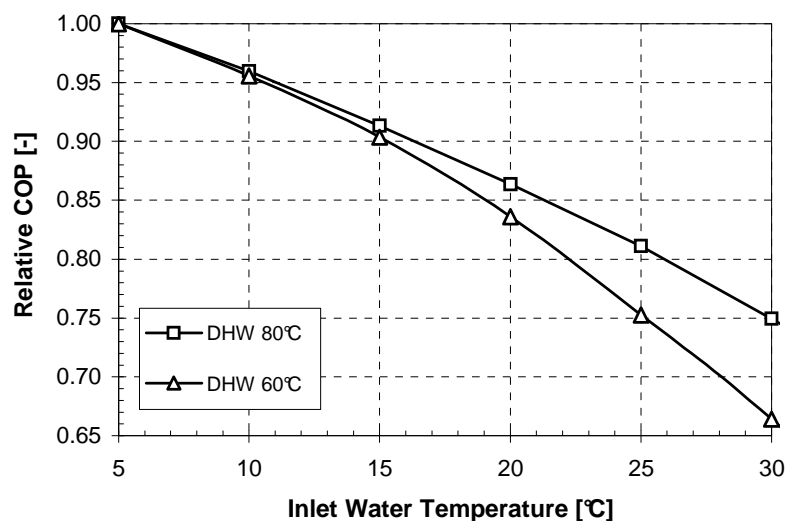

Figure 6 Simulated relative COPs for a CO₂ HPWH as a function of the inlet water temperature to the gas cooler at 60 and 80°C set-point temperature for the DHW (Stene, 2004).

⁴ Design Outdoor Temperature (DOT) – The lowest 3-day temperature during a 30-year period

⁵ Average ambient air temperature during the year

The DHW storage system for a CO₂ heat pump water heater should preferably use relatively small diameter tanks storage tanks connected in series in order to minimize conductive heat transfer between the DHW and the city water in the tanks. Efficient diffusers are also recommended at the tank inlets in order to minimize the water velocity and consequent mixing of hot and cold water. Figure 7 shows a principle drawing of the DHW system for the 26 kW CO₂ HPWH including four 1,000 litres single-shell storage tanks and an inverter controlled pump (Hjerkinn, 2007).

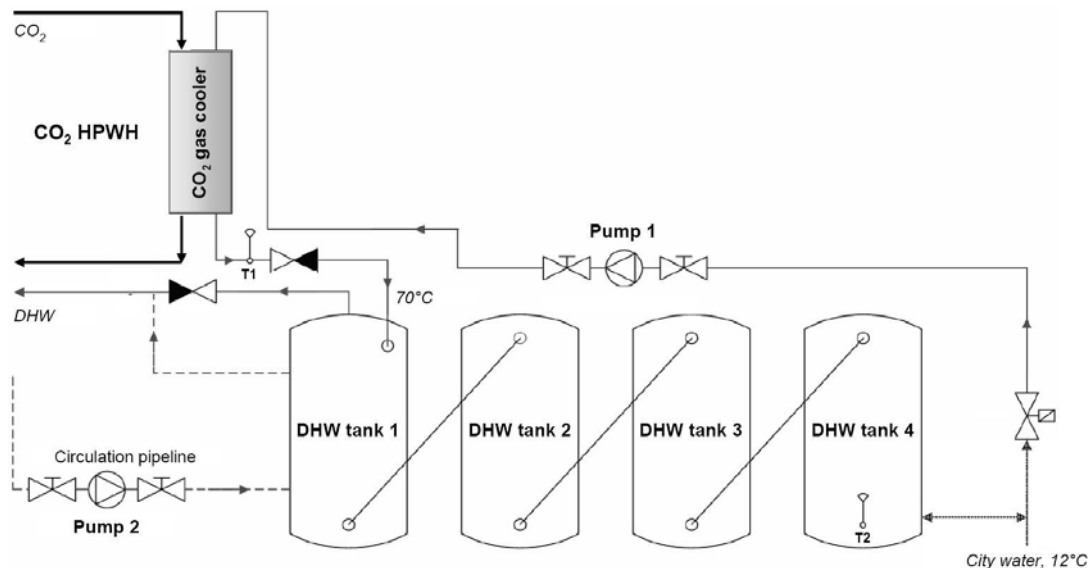

Figure 7 Principle sketch of the DHW system connected to the CO₂ HPWH (Hjerkinn, 2007).

3.2 Control Strategy

The DHW system was designed as a closed unvented (pressurized) system, where DHW tank 4 was connected to the city water supply (cold mains) and DHW tank 1 was connected to the tapping sites.

During the tapping periods, cold city water flows into the bottom of DHW tank 4 whereas the same amount of hot water is flowing from the top of DHW tank 1 to the tapping sites. The CO₂ heat pump will normally run during the tapping periods. An inverter controlled pump (Pump 1) circulates the cold city water to the gas cooler, where the water is being heated to the set-point temperature (T1) before it enters the top of DHW tank 1. When the tapping period has ceased the CO₂ heat pump will be running as long as the water temperature (T2) at the bottom of DHW tank 4 is lower than the set-point temperature (70°C). The gas cooler pressure for the CO₂ heat pump unit is continuously optimized in order to achieve the maximum COP for the heat pump at varying operating condition.

3.3 Simulations – COP and Profitability

The 26 kW CO₂ heat pump water heater (HPWH) was simulated in CSIM (Skaugen, 2002), which is an advanced computer programme developed at NTNU-SINTEF for optimization of CO₂ heat pumps.

When using groundwater at 7°C as the heat source, the calculated COP for the CO₂ HPWH was approx. 3.8. This corresponds to an *energy saving of about 70-75%* compared to a conventional DHW system with electric immersion heaters, and it is roughly 20-25 percentage points higher than that of a DHW system based on solar collectors and electric heaters for supplementary heating.

The maximum permissible investment cost (MPI) for the CO₂ HPWH system was calculated using the following boundary conditions:

- Annual heating demand: 170,000 kWh/year
- Heat pump, average COP: 3.5 – conservative value
- Real interest rate: 6%
- Economic lifetime: 15 years
- Electricity price: 0.1 €/kWh (0.75 NOK/kWh)
- Reference DHW system: Electric immersion heaters

The calculated maximum permissible investment cost was about €125,000 or 4,800 €/kW. It was therefore concluded that the CO₂ HPWH system will be a very profitable installation.

4. Summary and conclusion

“Bergen og Omegn Boligbyggelag” is about to construct a number of apartment buildings of passive house standard at Damsgårdssundet in Bergen, Norway. The total energy demand for hot water heating for one of the buildings with 40 flats has been estimated to be about 170.000 kWh/year, i.e. 4,250 kWh/year for each flat.

Four different heat pump designs were simulated in order to find the maximum theoretical coefficient of performance (COP). The simulations showed that a heat pump water heater using carbon dioxide (CO₂ as working fluid) will achieve about 20% higher COP than high-efficiency state-of-the-art heat pump systems. CO₂ is a non-flammable, non-toxic and environmentally friendly working fluid

An in-depth analysis was carried out for a 26 kW CO₂ heat pump water heater system. Four different heat sources were evaluated, including ambient air, sea water, ground water and grey water (waste water). The CO₂ heat pump unit was simulated with CSIM, which is an advanced simulation tool for design and optimization of CO₂ heat pump and air conditioning systems. The calculated COP for a CO₂ heat pump water heater using 7°C groundwater as heat source was about 3.8 when supplying 70°C hot water. This corresponds to a *net energy saving of about 70-75%* compared to state-of-the-art electric immersion heaters in single-shell hot water tanks. This is roughly 20-25 percentage points higher than that of Norwegian/Nordic DHW systems based on solar collectors and electric heaters for supplementary heating.

The calculated maximum allowable investment cost for the CO₂ heat pump water heater system was about €125,000 when assuming an average COP of 3.5, 6% real interest rate, 15 years system lifetime and an electricity price of approx. 0.1 €/kWh. Due to the high energy efficiency, the excellent profitability and the favourable environmental properties of CO₂, CO₂ heat pump water heaters are regarded as a very promising alternative for centralized hot water heating in apartment buildings and block of flats of low-energy and passive house standard. Air-to-water CO₂ heat pump water heaters in the capacity range from about 5 to 30 kW are now available from several Japanese manufacturers.

5. References

- Hjerkinn, T., 2007: *Analysis of Heat Pump Water Heater Systems for Low-Energy Block of Flats* (in Norwegian with English summary). Master thesis at the Norwegian University of Science and Technology (NTNU), Dept. of Energy and Process Engineering. EPT-M-2007-24.
- Skaugen, G., 2002. *Investigation of Transcritical CO₂ Vapour Compression Systems by Simulation and Laboratory Experiments*. Doctoral Thesis at the Norwegian University of Science and Technology (NTNU), Dept. of Energy and Process Engineering, 2002-141. ISBN 82-471-5536-2.
- Stene, J., 2004: *Residential CO₂ Heat Pump System for Combined Space Heating and Hot Water Heating*. Doctoral Thesis at the Norwegian University of Technology and Science, Dept. of Energy and Process Engineering, 2004:53. ISBN 82-471-6316-0.

⁶ 100 NOK = approx. 8.0 € (February 2008)

Session 3

Scenarios and feasibility studies

Timo Kalema, Petri Pylsy Low-energy house concepts for Nordic countries.....	66
Marit Thyholt, Tore Wigenstad Fjernvarmens rolle i fremtidens energieffektive boliger.....	74
David N. Benjamin The renovation of existing buildings to passive house standards: A literature review	81
Bjørn Jenssen Wachenfeldt, Igor Sartori Midt-Norge som pilotregion for passivhus satsing: Potensialstudie	82

Low-energy house concepts for Nordic countries

Timo Kalema, Tampere University of Technology

Petri Pylsy, Tampere University of Technology

Abstract

In Nordic countries low-energy and passive houses are mostly individuals designed for a certain building site and use. However, in order to increase the amount of low-energy houses it should be possible for builders to buy buildings with certain energy performance and costs. This paper presents results of a project, in which these concepts were developed for the use of building manufactures.

The annual energy use for heating for single-family houses fulfilling the new Finnish building regulations is in the weather conditions of South-Finland approximately 140 kWh/m²/a in which the share of hot water heating is 35 kWh/m²/a. This energy use is obtained with the new reference U-values for the exterior envelope, a 30 % efficiency for heat recovery from exhaust air and using for the tightness of the envelope the value $n_{50} = 4$ 1/h.

Concepts including the thermal insulation of the building's envelope as well as the main features of the heating and the ventilating systems for achieving an energy consumption for heating of 100 – 20 kWh/m²/a are analyzed. The analysis includes calculation of energy consumption for heating and the total costs including the investment and the energy costs. In addition an energy performance grading according to the new Finnish certification system has been calculated.

Without the use of a heat pump the lowest reasonable energy consumption for heating approximately is 60 kWh/m²/a. In this case the U-values of the insulated structures are approximately 0.10 W/Km² and that of the windows 0.85 W/Km². The average efficiency of the heat recovery must be high (70 %) and the envelope tight ($n_{50} = 0.6$ 1/h). Depending on the interest and the repayment time the allowable extra investment cost for this kind of low-energy house is approximately 20 000 €.

With the use of various heat pumps the energy consumption for heating can be reduced up to approximately 30 kWh/m²/a. In this case the allowable extra investment cost is approximately 35 000 €.

Introduction

It has been studied by calculations the following concepts for decreasing the energy consumption for heating of single-family houses:

good thermal insulation and tightness of the envelope

efficient heat recovery from exhaust air

various heat pumps as energy saving heating systems

Calculations are made for a 130 m² single-family house using the weather data of Helsinki. The energy performance grading is calculated using the weather data of Middle-Finland (Jyväskylä), which is the official weather for this purpose. The starting point of calculations is a house fulfilling the present Finnish building regulations. The basic values for energy price are the present ones and a certain increase of energy price is assumed. The basic real interest of calculations is 3 % and the calculation period is 30 years.

Four cases according the thermal insulation level of the envelope have been analysed. The specific transmission heat losses for the four cases are from 104 to 51 W/K. For all levels of thermal insulation four tightness levels of the envelope (n_{50}) varying from 4 to 0.6 1/h have been used. For the annual efficiency of the heat recovery three values varying from 0.30 to 0.70 have been used.

The heat pumps studied are exhaust air, outdoor air and ground heat pumps. The last ones can have either a ground coil or a drilled well as a heat source. Exhaust air and outdoor air heat pumps cover only a part of the heating load. The basic heat source can be either electric heating or district heating.

Finland has taken into use from the beginning of the year 2008 an energy performance grading for buildings. The grade is calculated from the total use of heating energy as the sum of the energy use for space and hot water heating and for the space cooling (Q_{sh} , Q_{kwh} , Q_{sc}), the heat losses of technical systems (heating and hot water devices) Q_{hl} and the electricity consumption of technical equipment E_{eq} divided by the gross floor area A_{gf} . The heat generation efficiency is not taken into account otherwise, but as heat losses of the heat generation system.

Equation for calculating **the energy performance grade (ET) or the total use of heating energy/gross floor area** is

$$ET = \frac{Q_{sh} + Q_{hwh} + Q_{sc} + Q_{hl} + E_{eq}}{A_{gf}} \quad (1)$$

Energy performance grade A is defined so, that the value of ET is less than 150 kWh/m²/a. Buildings just fulfilling the building regulations usually have an energy performance grade D, in which the total use of heating energy is 190 – 230 kWh/m²/a.

The following quantities for energy (Chapter 6) have been used:

- **Energy use for heating** is a net energy for space and hot water heating
- **Energy consumption for heating** is the purchased heating energy (fuel, electricity). It is calculated from the former by using a generation efficiency (coefficient of performance for heat pumps)
- **Total use of heating energy** is a quantity used in the Finnish energy certification system. It includes the energy quantities of Eq. 1. However, it does not take into account the energy saving due to a heat pump and not the flue gas heat loss of a boiler. Therefore electric heating systems having small heat losses of technical equipment have the best grading.

The results for energy are presented as specific values calculated per floor area. The specific values for the two first energy quantities are calculated for a fixed interior floor area and for the last one according to the Finnish system for a gross floor area, which includes the area taken by the insulation of exterior walls.

Input data of calculations

In the basic case of calculations (Case 1) the U-values of the components of the exterior envelope are according to the present Finnish reference values of building regulations. In addition to this three better thermally insulated envelopes (Cases 2 – 4) have been studied (Table 1).

The interior floor area of the single-family house studied is 130 m². Figure 1 presents the simple floor plan used in the analysis. The windows' area/floor area is 12 %. The windows are mainly facing towards south (53 %) and towards north (38 %). Table 2 presents their total solar transmission coefficients. The house is a wood frame house having a massive floor and its thermal capacity/floor area is 70 Wh/(m²K).

When improving the thermal insulation of the envelope the gross floor area calculated according to the outer dimensions increases from Case 1 to Case 4 by approximately 9 % due to thicker thermal insulation layers in exterior walls. This means that the increase of the floor area improves itself the calculated energy performance by 9 %. Naturally the improvement of the thermal insulation improves the energy performance much more.

The hot water consumption is 200 dm³/day and the internal heat gains 7.5 W/m² on the average. The annual mean exterior temperature is 4.3 °C and the solar radiation on a horizontal surface 936 kWh/m²/a (weather data of Helsinki).

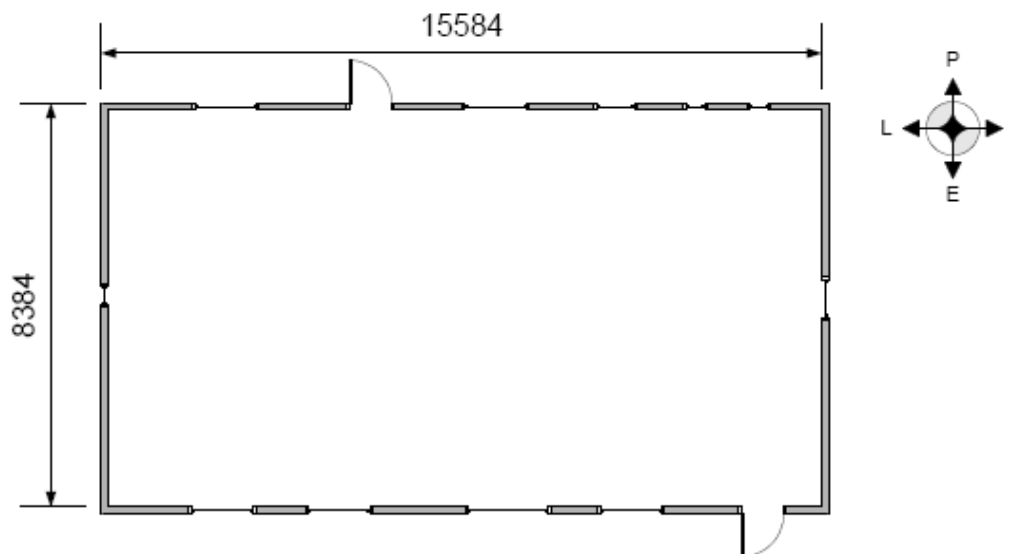

Figure 1. Simple floor plan of the single-family house studied.

Table 3 presents the heating systems studied, their investment costs and their estimated service costs for a 30 years period. Table 3 also includes the energy prices used and their somehow arbitrary estimated rates of increase. It has been estimated that the price of heating oil increases noticeably more rapidly than that of electricity or district heating.

The investment costs include the energy source, a water based floor heating for heat distribution (not in electric heating) and a separate hot water storage (electric heating). Electric heating, district heating, oil heating and heat pump heating using a drilled well as a heat source are basic heating systems, which can alone manage the full heating load. Air-to-air heat pumps and exhaust air heat pumps are additional heat sources for reducing the energy consumption.

For the annual efficiency of the heat recovery from exhaust air to supply air three values (30 %, 55 % and 70 %) are used and for the tightness of the building's envelope four values ($n_{50} = 4, 2, 1$ and 0.6 1/h). The basic value for real interest is 3% and that for the calculation period 30 a.

The energy performance grading for the cases studied is calculated according to the Finnish system. It includes default values (Table 4) for internal heat gains and rather high values for the electricity consumption of technical equipment and for the heat losses of technical systems.

Table 1. U-values for the exterior envelope for the four cases studied.

Construction	Case 1* U-value W/Km^2	Case 2 U-value W/Km^2	Case 3 U-value W/Km^2	Case 4 U-value W/Km^2
Exterior wall	0.24	0.18	0.12	0.10
Ground floor	0.24	0.15	0.12	0.10
Ceiling	0.15	0.15	0.09	0.08
Window, exterior doors	1.4	1.4	1.1	0.85

* Exterior envelope insulated according the present building regulations

Table 2. Properties of the envelope, windows and the gross floor-area.

	Unit	Case 1	Case 2	Case 3	Case 4
Specific heat loss	W/K	103,8	85,8	61,8	50,8
Average U-value	W/Km^2	0.27	0.22	0.16	0.13
Gross floor area	m^2	142	145	151	155
Relative gross floor area	%	100	102	106	109
Solar transmission of windows		0.567	0.567	0.567	0.45

Table 3. Properties of heating systems, their investment and service costs and energy price for a 30 years period.

System	Efficiency %	Investment cost €	Service cost €	Energy price s/kWh	Increase of energy price %/a
Electric heating (radiators)	100	2700	100	8.5	2.5
District heating	100	6400	800	5.2	2.5
Air-to-water heat pump	200	2600	1200	8.5	2.5
Exhaust air heat pump	220	6000	2100	8.5	2.5
Drilled well heat pump	250	12300	2100	8.5	2.5
Oil heating	85	6900	2700	7.2	7
Hot water heater (electric heating)	100	700	600	8.5	2.5
Water based floor heating		3700	800		

Table 4. Default values for electricity consumption of technical equipment, heat losses of technical systems and internal heat gains for a small house. Finnish energy certificate system.

Energy	$kWh/m^2/a$
Electricity for technical equipment	50
Heat losses of technical systems	26
Internal heat gains	66

Results

The energy use for heating for the single-family houses studied for the Helsinki weather including the space heating and that of hot water heating is from 140 to 55 $kWh/m^2/a$ calculated per interior floor area. The share of hot water heating in these numbers is 35 $kWh/m^2/a$ and the share of space heating 105 – 20 $kWh/m^2/a$. With the thermal insulation level of present building regulations (Case 1) the energy use for heating is 140 – 105 $kWh/m^2/a$. With the use of a very tight envelope and a heat recovery system with a high efficiency the energy use for heating can be reduced approximate by 35 $kWh/m^2/a$ (30 %). With the best level of thermal insulation

(Case 4) the energy use for heating is 85 – 55 kWh/m²/a. Also in this case the use of the best tightness and the best heat recovery reduce the energy use for heating by 35 kWh/m²/a.

The following effects on the energy use for space heating can be seen from Figure 2:

- The effect of the tightness between the best and the worst envelope is approximately 10 - 15 kWh/m²/a
- The effect of the efficiency of the heat recovery system between the best and the worst heat exchanger is approximately 20 kWh/m²/a
- The effect of the envelope's thermal insulation is at its maximum 50 kWh/m²/a.

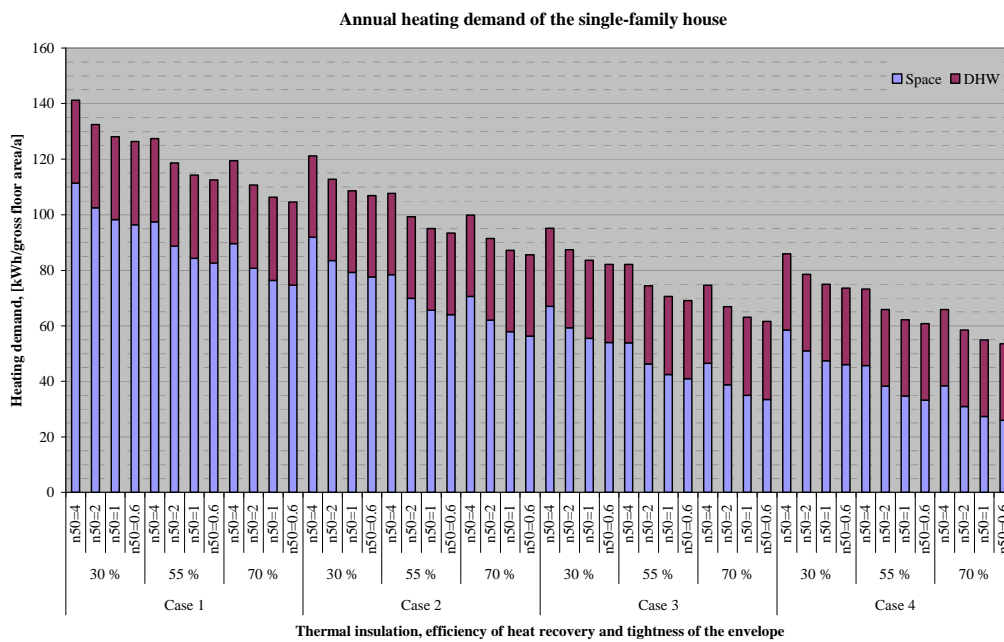

Figure 2. Energy use for heating/interior floor area of the single-family house depending on the thermal insulation of the envelope, the efficiency of the heat recovery and the tightness of the envelope.

The energy consumption for heating/interior floor area (energy consumed in the building as electricity, district heating or fuel) has a very high spread, 180 – 20 kWh/m²/a (Figure 3). The lowest energy consumption is obtained with heat pumps having a drilled well as a heat source. The boilers have the highest energy consumption due to flue gas heat losses.

The total use of heating energy/gross floor area, the official Finnish energy grading (ET), calculated using the values of building regulations (Table 4) is from 230 to 120 kWh/m²/a (Figure 4). These are high values when compared e.g. with the energy consumption of the passive house definition, which is 15 kWh/m²/a for space heating or when compared with the heating energy consumption of Figure 3.

There are two reasons for the high total use of heating energy. First the energy use for space heating in the Finnish climate is approximately a double compared with that of Central-Europe. Second the values used for the electricity consumption and for the heat losses of technical systems are default values of Finnish building regulations. These values are rather high because they are on the safe side and they are meant for the analysis of conventional buildings. It is clear that when buildings are very well insulated and when their total use of heating energy reduces then also the heat losses of technical systems and their electricity consumption reduce. This effect has been taken roughly into account in our calculations by reducing the electricity consumption and the heat losses of technical systems by 50 % from the values of Table 4 for the Cases 3 and 4 having the best insulated envelopes. This change also decreases internal heat gain by approximately 16 kWh/m²/a in water based heat distribution systems.

The energy performance grading (Table 5) for the buildings studied is from D to A (Figure 4) according to the Finnish system. The grading does not take into account the energy saving due to a heat pump and not the flue gas heat loss of a boiler. Therefore electric heating systems having small heat losses in technical equipment have the best grading.

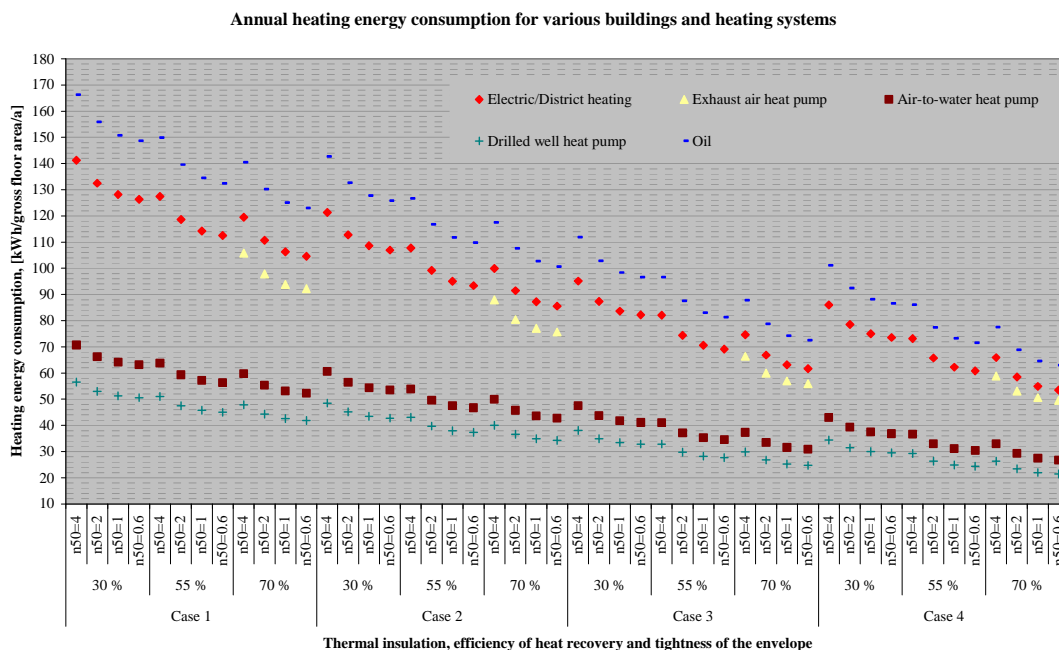

Figure 3. Energy consumption for space and hot water heating for various buildings and heating systems.

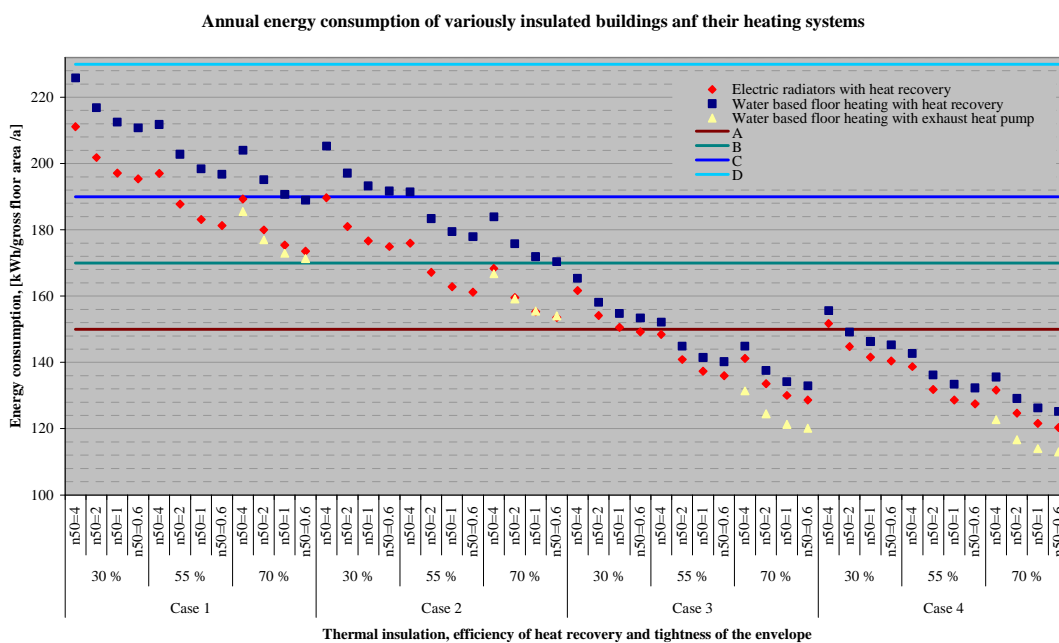

Figure 4. Total use of heating energy /gross floor area (ET) and energy performance grading of variously insulated buildings and their heating systems. Jyväskylä weather.

An allowable additional cost due to energy saving measures depends on the annual energy saving obtained. The highest energy savings are obtained in buildings having heat pumps utilizing drilled wells as heat sources. The smallest energy savings are in buildings having as an energy saving measure only the improvement of the heat recovery system or the tightness of the envelope. When the real interest is 3 % and the calculation period 30 years the allowable additional cost can be 0 ... 40 000 € for improving the energy performance from the level of building regulations.

Table 5. Finnish energy performance grading for single-family houses.

Energy performance grading	Total use of heating energy* (ET)/ gross floor area <i>kWh/m²/a</i>
A	< 150
B	150 ... 170
C	170...190
D	190...230
E	230...270
F	270...320
G	>320

* Energy use includes space and hot water heating and electricity consumption and heat losses of technical equipment.

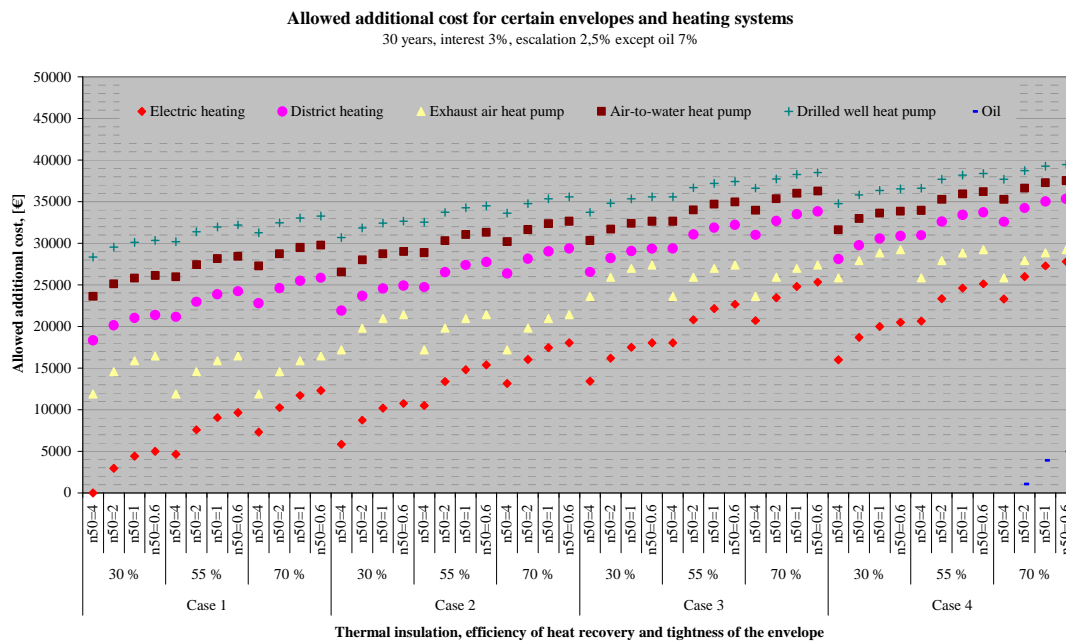

Figure 5. Allowed additional costs for certain level of buildings' thermal insulation and tightness of envelope as well as for certain heating systems.

Conclusions

It can be designed low-energy single family houses for Finnish climate conditions having an energy use for space and hot water heating approximately 50 – 100 kWh/m²/a. A low energy use for heating is obtained with a good thermal insulation, an efficient heat recovery from exhaust air and a good tightness of the envelope. The total use of heating energy including the heat losses and the electricity consumption of technical equipment for these buildings is 120 – 180 kWh/m²/a corresponding to the Finnish energy performance grades A – C. These numbers don't include the possible energy saving obtained with heat pumps. With the use of ground or drilled well heat pumps the electricity consumption of heat pumps is 30 – 60 kWh/m²/a. Depending on the energy saving obtained compared with buildings constructed according to the present building regulations the additional investment costs of the low-energy houses can be up to 40 000 € higher than those of the buildings just fulfilling the requirements.

References

Pylsy, P., Development of low-energy house concepts for single-family houses. Diploma work. Tampere University of Technology. Tampere 2008 (still under work).

Calculation of buildings' energy consumption and heating effect. Guidelines 2007. Ministry of Environment. Helsinki 2007.

Energy performance of buildings. Guidelines and orders 2007. Ministry of Environment. Helsinki 2007.

Thermal insulation of buildings. Orders 2007. Ministry of Environment. Helsinki 2007.

Dof-Energy. www.dof.fi

Promotion of European passive houses. www.europeanpassivehouses.org

ISO/DIS 13790 (2005). Thermal Performance of Buildings – Calculation of Energy Use for Space Heating and Cooling, ISO TC 163/SC 2. International Organization for Standardisation. Geneva.

Definitions

- Energy use for heating** Net energy for space and hot water heating. The energy use for space heating is calculated by using the principles of ISO FDIS 13790. In this paper this quantity is calculated per interior floor area.
- Energy consumption for heating** Energy use for heating divided by the efficiency (coefficient of performance for heat pumps) of the heat generating system. Calculated per interior floor area.
- Total use of heating energy** Includes the energy use for heating, the heat loss of technical systems and the electricity consumption of technical equipment. Calculated per gross floor area (outside dimensions) according to the official Finnish system.

Fjernvarmens rolle i fremtidens energieffektive boliger

Marit Thyholt, SINTEF Byggforsk, Alfred Getz vei 3, 7465 Trondheim
Tore Wigenstad, SINTEF Byggforsk, Alfred Getz vei 3, 7465 Trondheim

Sammendrag

Sett i lys av et stadig mindre energibehov til romoppvarming i ny boligmasse, er det gjennomført en spørreundersøkelse blant norske fjernvarmeprodusenter for å kartlegge i hvilken grad disse anser at lavere varmebehov vil påvirke deres beslutninger med hensyn til å kunne levere fjernvarme til slike områder. Målet med undersøkelsen har vært å belyse om myndighetenes målsetninger om økt satsing på fjernvarme og redusert varmebehov i ny boligmasse kan være motstridende. Undersøkelsen anses også å ha høy nytteverdi i forhold til økt kunnskap om utfordringer knyttet til kombinasjon av energieffektivitet og mer bruk av fornybar energi. Slik kunnskap er nødvendig i arbeidet med å redusere barrierer for gjennomføring av begge disse tiltakene.

Av svarene fra undersøkelsen kan en generelt si at alle fjernvarmeselskapene som deltok i undersøkelsen forventer at mer energieffektiv boligmasse vil ha betydning for deres beslutninger mht å kunne levere fjernvarme til slike områder. Resultatet innebærer at det er en motsetning mellom de nasjonale målene om lavere varmebehov i ny boligmasse og økt bruk av fjernvarme.

2. Bakgrunn

2.1 Motstridende nasjonale virkemidler

Lavere varmebehov i nye boliger er en nasjonal målsetning. Skjerpede krav i reviderte tekniske forskrifter til varmebehov, samt bygging av lavenergi¹- og passivhus², bidrar til denne målsetningen. En ønsket konsekvens er at varmebehovet i nye utbyggingsområder blir vesentlig redusert sammenlignet med varmebehovet i de områdene som har blitt utbygget inntil i dag. Myndighetene har også en målsetning om at bruken av fjernvarme skal økes. Lavere varmebehov reduserer imidlertid lønnsomheten ved å føre frem fjernvarme, og vil således kunne påvirke den nasjonale satsingen på økt bruk av fjernvarme. Dette er et aspekt som ikke har vært vurdert, verken i forbindelse med nye forskriftskrav eller i tilknytning til myndighetenes incentivordninger rundt bygging av lavenergi- og passivhus. Ei heller i klimaforliket på Stortinget i januar er dette motsetningsforholdet vurdert.

2.2 Energieffektivisering

I Norge er det siden tusenårsskiftet skjedd en stor endring i interessen for bygging av lavenergi- og passivhus. I følge Husbanken var det i januar 2006 var rundt 3000 lavenergi- eller passivhusboliger enten under planlegging, bygging eller allerede bygget. Ett år etter var tilsvarende tall omlag 10.000 boliger. Det var spesielt etter den kalde og tørre vinteren mellom 2002 og 2003, da prisene for elektrisitet til husholdningene ble rekordhøye (SSB, 2008), at interessen for bygging av denne type boliger økte. Norske myndigheter har også som målsetning at nye boliger skal bli mer energieffektive. Nye og atskillig skjerpede energikrav for boliger ble innført i tekniske forskrifter i 2007 (KRD, 2007). Sammenlignet med forskriften fra 1997 innebærer denne skjerpelsen omlag 60 % redusert energibehov til romoppvarming og oppvarming av ventilasjonsluft³. I januar 2008 inngikk regjeringen og tre opposisjonspartier på Stortinget et klimaforlik, hvor partene ble enige om at erfaringene med

¹ Boliger med et årlig energibehov i størrelsesorden 100 - 130 kWh/m². Til sammenligning utgjør årlig energibehov for boliger bygget etter tekniske forskrifter fra 1997 ca 180 kWh/m².

² Boliger med et årlig energibehov i størrelsesorden 80 kWh/m², og et årlig oppvarmingsbehov rundt 20 kWh/m²

³ Reduksjonen på 60 % forutsetter mekanisk avtrekksventilasjon for 1997-nivået

passivhus skal følges opp, og at det skal vurderes å innføre krav om passivhusstandard for alle nybygg innen 2020 (Regjeringen, 2008). Statsforetaket Enova, som eies av Olje- og Energidepartementet, bidrar med økonomisk støtte til energieffektivisering i bygningsmassen. I tillegg har Husbanken, som med sine tilskuddsordninger har vært en viktig pådriver i arbeidet med å fremme bygging av lavenergi- og passivhusboliger, som målsetning at antall boliger med halvert energibehov skal utgjøre 50 % av all nybygging i 2010 sammenlignet med forskriftskravene fra 1997 (Husbanken, 2008).

I figur 1 er årlig energibehov for en typisk boligblokk⁴ illustrert, avhengig av hvilken energistandard bygget har. Figuren illustrerer samtidig endringen i varmemarkedet over tid. For boligblokk med passivhusstandard er det forutsatt at 40 % av varmtvannsbehovet er dekket via solfangeranlegg. Eksempelvis vil en bolig med lavenergistandard ha et samlet varmebehov, inkludert oppvarming av tappevann, i størrelsesorden rundt 40 % av tilsvarende varmebehov for en bolig bygget i henhold til minstekravene fra 1997. For passivhus i dette tilfellet er tilsvarende tall ca 25 %.

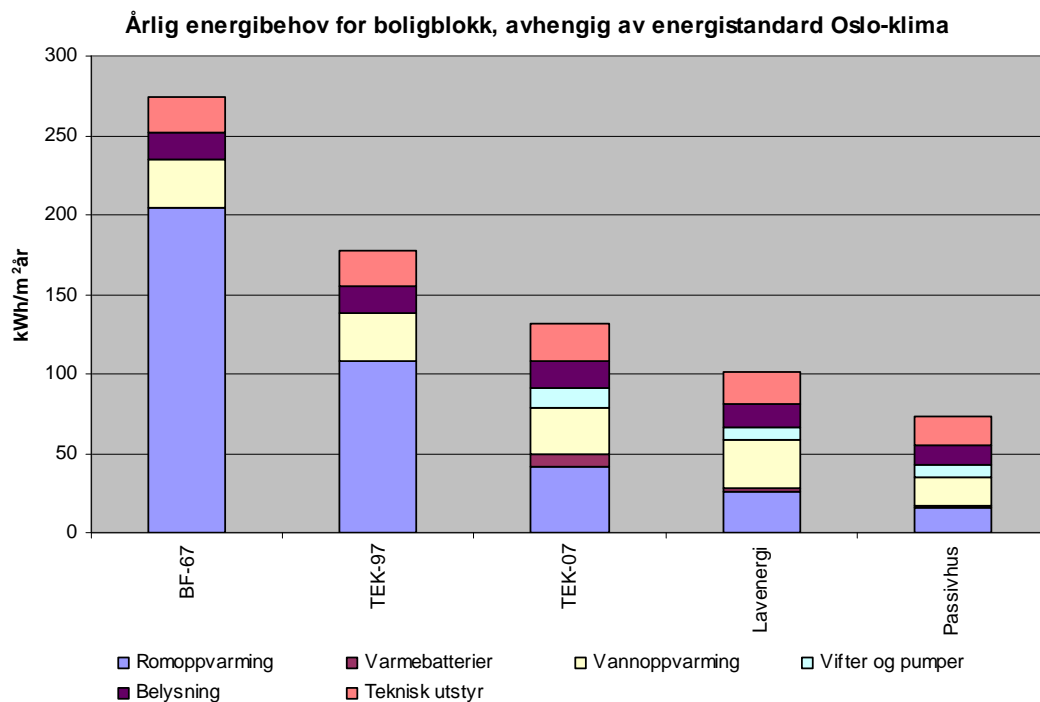

Figur 1. Spesifikk årlig energibehov (levert/kjøpt energi) for en boligblokk (tenkt case). "BF-67" tilsvarer standard i henhold til byggeforskrift fra 1967. "TEK-97" og "TEK-07" tilsvarer standard i henhold til tekniske forskrifter fra henholdsvis 1997 og 2007. "Lavenergi" og "Passivhus" tilsvarer lavenergistandard og passivhus-standard.

I figur 2 er det vist hvordan energibehovet til romoppvarming i samme boligblokk som i figur 1 kan variere over året, avhengig av bygningens energistandard. Figuren illustrerer også at varmebehovet over året svinger vesenlig mindre for lavenergi- og passivhus enn boliger bygget frem til nå.

⁴ Boligblokk med tre etasjer, totalt 1200 m² oppvarmet bruksareal. Oslo-klima.

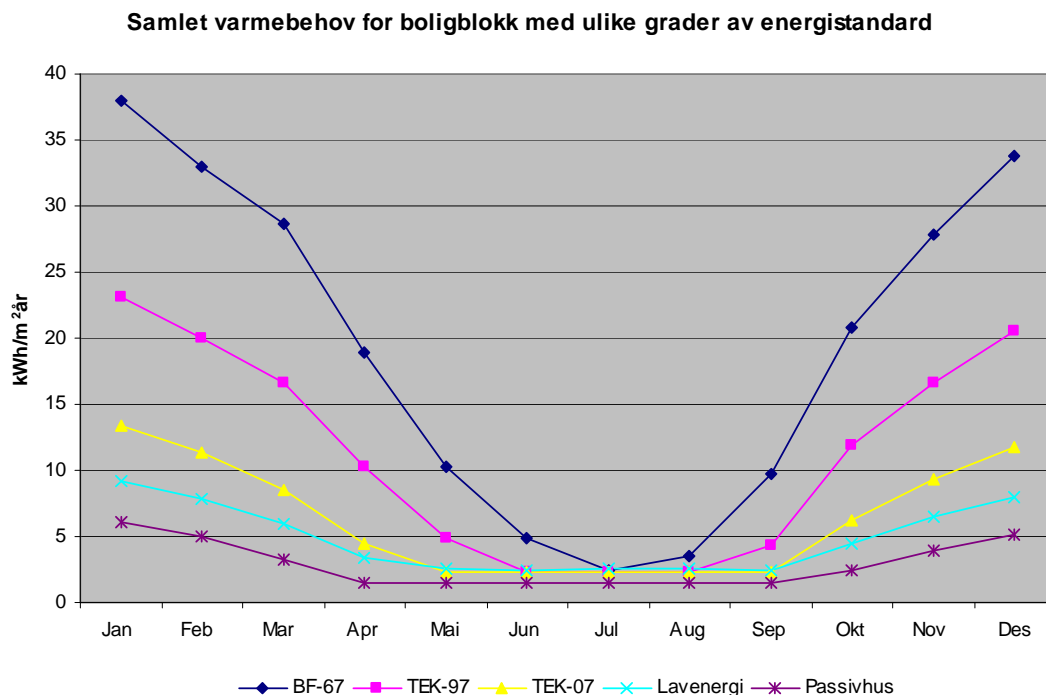

Figur 2. Varmebehov per måned (gitt per m² oppvarmet bruksareal) for boligblokk i Oslo-klima, med ulike energistandarder. Inkludert varmebehov til tappevann.

2.3 Økt bruk av fjernvarme

Myndighetene har også målsetning om økt bruk av fjernvarme. Enova har eksempelvis målsetning om 4 TWh økt varmeproduksjon innen 2010 (med referanse 2001) basert på andre energibærere enn fossile brenslere og elektrisitet. Fjernvarme sorterer under denne satsingen, og økonomiske støtteordninger skal bidra til å nå målet. I klimaforliket fra januar 2008 mellom regjeringen og tre opposisjonspartier ble partene enige om at vilkårene for utbygging av fjernvarme må styrkes (Regjeringen, 2008). Det samfunnsmessige motivet for økt utbygging av fjernvarmekapasiteten er en mer miljøvennlig og energifleksibel energiforsyning. For å sikre det økonomiske grunnlaget for utbygging og drift av slike anlegg kan kommunen i henhold til Tekniske forskrifter § 8-23 (KRD, 2007) kreve at bygninger som oppføres innenfor et konsesjonsområde for fjernvarme, tilknyttes fjernvarmenettet.

2.3.1 Vannbåren varme

Krav om varmeanlegg som kan tilknyttes fjernvarmeanlegg har i flere utbyggingsprosjekter vist seg å komme i konflikt med bygging av lavenergiboliger (Thyholt, 2006). Utbyggerne av disse prosjektene fant at kostnadene knyttet til vannbasert varmeanlegg for romoppvarming, i tillegg til frivillige energispareiltak, totalt ble for høye til å gi akseptabel lønnsomhet i byggeprosjektet. Utbyggerne ønsket heller å benytte et rimeligere elektrisk varmeanlegg. Det var derfor ikke selve tilknytningsplikten som ble opplevd som problematisk, men heller kravet om romoppvarmingsanlegg som kan tilknyttes fjernvarmeanlegg.

Mer kostnadseffektive vannbaserte varmesystemer, tilpasset lavere varmebehov, er nå under utvikling og utprøving i Norge (Fossdal, 2007). Denne produktutviklingen er et resultat av at det i flere byggeprosjekter har vært demonstrert betydelig motvilje mot å investere i vannbaserte varmeanlegg i boliger med lavt varmebehov. Mer kostnadseffektive vannbaserte varmeanlegg vil i større grad kunne bidra til at slike anlegg kan erstatte elektrisk oppvarming i boliger med lavt oppvarmingsbehov. En konsekvens vil sannsynligvis også være at utbyggere av boliger med lavt varmebehov i større grad enn hva som har vært demonstrert til nå finner at lavenergi og fjernvarme lar seg kombinere.

I februar 2008 la regjeringen ved Miljøverndepartementet frem forslag om en helt ny plandel av plan- og bygningsloven. I henhold til dette forslaget vil den nye loven gi lokale myndigheter muligheten til å stille krav

om tilrettelegging for at bygninger og anlegg skal forsynes med vannbåren varme. Dette innebærer at kommunen kan fastsette slikt krav i kommuneplanen og følge opp kravet når det utarbeides reguleringsplaner og utbyggingsavtaler for konkrete utbyggingsprosjekter (MD, 2008). Regjeringen legger opp til at loven kan tre i kraft fra 1. juli 2009. Krav om tilrettelegging for vannbåren varme i nye utbyggingsområder vil også bidra til at boligutbyggere i fremtidens lavenergibebyggelse ikke lenger vil sette lavenergiltak opp mot fjernvarmetilknytning i sin planlegging.

I flere nye lavenergi- og passivhus som nå planlegges eller er under bygging, baseres deler av varmforsyningen til boligene på fornybar energi⁵. Et eksempel på dette er Løvåshagen BL i Bergen, hvor det skal benyttes solfangeranlegg på tak (Husbanken, 2007b). For slike utbyggingsområder vil også fjernvarme være aktuelt der det foreligger tilknytningsplikt (i områder med fjernvarmekonsesjon), med tilhørende krav om varmeanlegg som kan tilknyttes fjernvarmenettet. For bydelen Damsgårdsundet i Bergen, hvor det planlegges bygging av lavenergiboliger, planlegges bruk av fjernvarme i kombinasjon med sol fra solfangeranlegg (Husbanken, 2007a).

2.3.2 Lønnsomhet for fremføring av fjernvarme

I årene fremover kan vi vente oss flere store utbyggingsprosjekter med lavenergi- eller passivhusstandard innenfor byområder hvor det er konsesjon for fjernvarme. I slike områder vil kommunen måtte vurdere eventuell tilknytningsplikt til fjernvarmeanlegg. Slike vurderinger er som oftest basert på om fjernvarmeprodusenten finner det lønnsomt og ønskelig å føre frem fjernvarme til slike områder. Lavere varmebehov vil imidlertid påvirke lønnsomheten ved å føre frem fjernvarme til nye boligområder. Konsekvenser av dårligere lønnsomhet kan være at fjernvarmeprodusenten finner det mindre økonomisk interessant å levere fjernvarme til nye boligområder, sammenlignet med dagens situasjon⁶. Dersom fjernvarmeprodusenten avstår fra å levere fjernvarme, eller avstår fra å søke konsesjon for nye områder, kan elektrisk oppvarming i stedet bli resultatet. Dette vil være i strid med myndighetenes målsetning om redusert bruk av elektrisitet til varmeformål. Men også varme basert på solfanger-, biobrensel- og varmepumpeanlegg kan være alternative løsninger.

I områder hvor en fjernvarmeprodusent har konsesjon, har produsenten i henhold til energilovens § 5-5 adgang til å kreve tilknytningsgebyr (OED, 2007). Praktiseringen av denne avgiften varierer i dag mellom de ulike fjernvarmeselskapene. Dårligere lønnsomhet ved å føre frem fjernvarme vil kunne bidra til at fjernvarmeprodusentene i større grad enn i dag tar i bruk slikt gebyr som kompensasjon for lavere fremtidige inntekter. Økt bruk av slik avgift, eller høyere avgift, vil samtidig innebære økte kostnader for boligutbygger, som vil komme i tillegg til de ekstra byggekostnadene som er nødvendige for å oppnå lavere varmebehov.

Faktorer som for fjernvarmeprodusenten i en viss grad kan kompensere for lavere lønnsomhet på grunn av redusert varmeetterspørsel, kan være:

- Vaskemaskiner som benytter varmt tappevann kan i fremtiden bli mer vanlig. Her kan fjernvarme benyttes.
- I områder med fjernvarme, som er typisk byer og større tettsteder, er tomteutnyttelsen i dag ofte svært høy. Dette bidrar til mer konsentrert boligareal
- Investeringskostnadene i spisslastanlegg i fjernvarmeproduksjonen vil kunne reduseres som følge av jevnere varmeetterspørsel over året
- Prisen på fjernvarme følger prisen på alternative energivarer hos kundene. Økte energipriser vil dermed også kunne resultere i økte fjernvarmepriser og høyere fortjenestemargin.
- Økonomiske støtteordninger
- Ta i bruk tilknytningsavgift

⁵ Inkluderer ikke elektrisitet basert på fornybar energi

⁶ Regler rundt tilknytningsplikt (og leveringsplikt), og kommunens aksept fra å gi dispensasjon fra eventuelt vedtatt tilknytningsplikt, er selvfølgelig en faktor som kan påvirke et slikt valg.

3. Spørreundersøkelse

3.1 Gjennomføring av spørreundersøkelsen

Sett i lys av et stadig mindre energibehov til romoppvarming i ny boligmasse, er det gjennomført en spørreundersøkelse blant norske fjernvarmeprodusenter for å kartlegge hvordan disse vurderer fremtidig fjernvarmeleveranse til nye boligområder. Målet med undersøkelsen har vært å belyse om myndighetenes målsetninger om økt bruk av fjernvarme og redusert varmebehov i ny boligmasse kan være motstridende. Undersøkelsen anses også å ha høy nytteverdi i forhold til økt kunnskap om utfordringer knyttet til kombinasjon av energieffektivitet og mer bruk av fornybar energi. Slik kunnskap er nødvendig i arbeidet med å redusere barrierer for gjennomføring av begge disse tiltakene.

Spørreundersøkelsen ble gjennomført blant syv (7) norske fjernvarmeselskaper, som samlet representerer ca 70 % av den totale årlige fjernvarmeproduksjonen i Norge. Resultatene fra undersøkelsen som presenteres her, er basert på svar fra 6 av disse selskapene. Svar fra det siste selskapet kommer for sent til å inngå i denne publikasjonen, men vil inngå i resultatene som presenteres under passivhuskonferansen i april 2008. Undersøkelsen ble gjennomført i februar i 2008.

Det var kun gitt ett spørsmål som primært var ønsket besvart. Det ble også presisert at det var ønskelig at svaret ble utdypet slik at resultatet fra undersøkelsen lettere kunne forstås og forklares. Det ble i tillegg oppfordret til å komme med informasjon og kommentarer som ikke direkte berørte det stilte spørsmålet, men som har relevans for å få økt kunnskap om problemstillingen.

Følgende spørsmål ble stilt:

I hvilken grad anser fjernvarmeprodusenten at lavere oppvarmingsbehov (romoppvarming og oppvarming av ventilasjonsluft) i ny boligmasse vil endre selskapets beslutninger med hensyn til leveranse av fjernvarme til nye boligområder? Spørsmålet forutsetter at kommunen ikke krever tilknytningsplikt dersom fjernvarmeprodusenten ikke ønsker dette.

Vennligst sett kryss fra 1 (ingen betydning) til 5 (svært stor betydning).

1 **2** **3** **4** **5**

Andre kommentarer til den belyste problemstillingen.

Stikkord:

- Vil tilknytningsavgift bli aktuelt for å kompensere for lavere inntekter?
- Vil andelen av fornybar energi og avfall i fjernvarmeproduksjonen øke i årene fremover?
- I hvilken grad erfarer fjernvarmeprodusenten at det har vært motstand mot tilknytning til fjernvarmenettet i byggeprosjekter med lavenergiboliger – og hva har eventuelt argumentene fra boligutbyggere vært?
- Erfarer fjernvarmeprodusenten at kommunen krever at vedtatt tilknytningsplikt opprettholdes, selv om produsenten ikke ønsker dette for bestemte områder?
- Andre kommentarer

3.2 Resultater fra spørreundersøkelsen

I tabellen under fremkommer hvordan fjernvarmeselskapene som deltok i undersøkelsen vurderer spørsmålet om betydningen av lavere varmebehov i ny boligmasse for fremtidig leveranse av fjernvarme til slike boligområder.

Tabell 1. Antall svar for de ulike svaralternativene. 1=ingen betydning, 5=svært stor betydning.

Svaralternativ	1	2	3	4	5
Antall	0	1	3	1	1

Fjernvarmeselskapene begrunner sine svar på følgende måte (kobling mellom svaralternativ og begrunnelse er ikke vist):

- *”Utbyggingskostnaden for fjernvarme er så høy at med mindre kWh å fordele utbyggingen på så vil det bli ulønnsomt med fjernvarme til boliger.”*
- *”Lønnsomheten i denne typen tilknytninger er i utgangspunktet dårlig pga. generelt høye tilknytningskostnader (rør- og gravekostnader) og liten energiomsetning. Selskapet vurderer allerede i dag småhus-/eneboligmarkedet som til dels ulønnsomt og lite interessant i vår utbyggingsstrategi. Legges det på den annen side til rette med gode støtteordninger for tilknytning, så kan dette kompensere for lavt og lavere oppvarmingsbehov. Det samme vil være tilfelle dersom betalingsviljen til kundene høynes ved at alternativ energipris (strøm, olje) forblir på et høyt nivå, eventuelt med offentlige avgifter som virkemiddel.”*
- *”Enhver utbygging av fjernvarmenett krever et behov for energi som vil gjøre investeringen fra fjernvarmeselskapet lønnsom på sikt. Minsker behovet pr boenhet betraktelig, kreves det at boligområdet er av en størrelse som veier opp for dette.”*
- *”Antallet kvadratmeter vil kompensere for bortfallet av energiforbruk i det enkelte bygg. Over tid kan endringen imidlertid få større betydning.”*
- *”Det vil være den totale økonomien som bestemmer om ett nytt boligfelt vil bli utbygd med fjernvarme. Både total utnyttelsesgrad (dvs. enebolig, rekkehus eller blokk) og forventet kWh/m² vil bli lagt til grunn. Marginen mellom energisalg og energikjøp skal dekke investering i nett og sentraler, drift og gi avkastning. Hvis investeringen økes må marginen økes. Dvs økte energipriser eller en gunstig energikilde.”*
- *”Fjernvarmeselskapets utbygging omfatter mange typer boligfelter og det er derfor umulig å svare presist på spørsmålet. I prinsippet er det likevel slik at dersom varmetettheten blir lav nok vil det kunne være aktuelt å la være å tilknytte det til fjernvarmenettet. På den annen side vil støtte som skal utløse ulønnsom fjernvarmeutbygging være med på å oppveie for dette til en viss grad.”*

I spørreundersøkelsen ble det også oppfordret til å komme med informasjon eller kommentarer som ikke direkte berørte det konkrete spørsmålet som ble gitt, men som er relevant for problemstillingen. Denne tilleggsinformasjonen er ikke referert her.

4. Konklusjon

Av svarene oppsummert i tabellen kan en generelt si at alle fjernvarmeselskapene som deltok i undersøkelsen forventer at mer energieffektiv boligmasse har betydning for deres beslutninger mht å kunne levere fjernvarme til boligområder med lavt varmebehov. I hvilken grad varierer imidlertid, men 5 av 6 gir svaralternativ 3 (en del betydning) eller høyere (høy eller svært høy betydning). Fjernvarmeselskapene som har deltatt i undersøkelsen representerer omlag 65 % av den totale fjernvarmeproduksjonen i Norge. På bakgrunn av dette, og de svarene som er gitt, kan en konkludere med at det er en motsetning mellom de nasjonale målene om lavere varmebehov i ny boligmasse og økt bruk av fjernvarme⁷. For å oppnå myndighetenes målsetning om økt bruk av fjernvarme, synliggjør resultatet også at det er behov for tiltak⁸ for å sikre lønnsomheten knyttet til fremføring av fjernvarme til nye boligområder med lavt varmebehov.

⁷ Undersøkelsen er ikke lagt opp slik at motsetningsforholdet kan tallfestes på noen måte. Til dette kreves en mye mer omfattende studie, inkludert økonomiske lønnsomhetsanalyser.

⁸ Eksempelvis økonomiske støtteordninger, kostnadseffektivisering knyttet til produksjon og distribusjon av fjernvarme og infrastruktur for fjernvarme.

Referanser

- Fossdal, S. (2007), Enkle vannbårne systemer for lavenergiboliger. SINTEF Byggforsk, Prosjekt-/arkivnummer: 9995.,
- Husbanken (2007a),
www.husbanken.no/Venstremeny/Universell%20utforming/~media/Venstremeny/Universell%20utforming/Bergen070524c.ashx.
- Husbanken (2007b),
www.lavenergiboliger.no/hb/lavenergi.nsf/viewProsjekter/1EE135C08687D533C12572DB003A7F38?OpenDocument.
- Husbanken (2008), <http://www.lavenergiboliger.no>.
- KRD (2007), Tekniske forskrifter til plan- og bygningsloven. 1997. Ajourført med endringer, senest ved forskrift av 26. januar 2007 nr. 96. Kommunal- og regionaldepartementet,
- MD (2008), Ot.prp. nr. 32 (2007-2008). Om lov om planlegging og byggesaksbehandling (plan- og bygningsloven) (plandelen). Miljøverndepartementet,
- OED (2007), Lov om produksjon, omforming, overføring, omsetning, fordeling og bruk av energi m.m (energiloven). Sist endret i 2007. Olje- og energidepartementet,
- Regjeringen (2008), Avtale om klimaforlik. Januar, 2008
- SSB (2008), <http://www.ssb.no/emner/10/08/10/elkraftpris/>. Januar, 2008
- Thyholt, M. (2006), Varmeforsyning til lavenergiboliger i områder med fjernvarmekonsesjon. Analyser av CO₂-utslipp og forsyningsikkerhet for elektrisitet. PhD-avhandling, Norges teknisk-naturvitenskapelige universitet

The renovation of existing buildings to passive house standards: A literature review

David N. Benjamin, PhD, Sivilarkitekt, MNAL LEED AP, Fridtjof Nansens Pl. 9, 0160 Oslo, Norge

Most of the buildings we will inhabit 40 years hence already exist, yet by 2050 the world needs to have a climate neutral infrastructure, or at least to reduce climate gas emissions to about 80% under 1990 levels. Since world building activity accounts for about 38% of all primary energy consumption (The Inter Academy Council, 2007), policies and implementation mechanisms are needed to significantly increase the energy efficiency of the existing structures of today, even up to passive house standards. (see the portal <http://www.passiv.de>). This upgrading process should begin immediately as modifying the building stock will take many years, and at the same time, upgrading buildings is a relatively simple procedure compared to other climate policy initiatives, such as changing people's energy use patterns or decoupling Gross Domestic Product from primary energy use.

The literature on the modification of existing buildings to passive house standards is mostly still available on the web, concerning general articles on the subject and case studies. Three papers from the Passivhaus Institut in Darmstadt, in German, provide more detailed information on the technical aspects of passive house upgrades. (*Lüftung bei Bestandssanierung: Lösungsvarianten, Einsatz von Passivhaustechnologien bei der Altbau-Modernisierung*, and *Faktor 4 auch bei sensiblen Altbauten: Passivhauskomponenten + Innendämmung*, available at <http://www.passiv.de>) Hopefully these papers will soon be translated into English. The same portal also provides case studies of those existing structures that have been certified as passive houses. Several other sources online and in print do provide information relevant to the energy efficiency upgrading of buildings. This paper looks at a selection of these sources from the United States, Canada, the U.K., the EU, and Scandinavia. Other programs relevant to this upgrade imperative to passive house standard include the BRITA in PuBs website, part of the EU Intelligent Energy program, which has also held one international conference on the subject (<http://edit.brita-in-pubs.eu/> and <http://www.brita-in-pubs.com/summary.html>), and the BRE program for existing structures, especially Victorian buildings, focused on the United Kingdom (www.brepress.com).

The buildings are as of February 2008 made up of three single family houses, three apartment houses, one day care center, and one small office/administration building, all but one of them in Germany and one in Austria. This stands in stark contrast to the popularity of building new passive houses, about 15,000 at last count and rising every day. This situation highlights the need for national architectural, engineering, and building contractor associations, together with national and regional policymakers and politicians, to find ways to bring more incentives to bear on the economic actors making the facility procurement decisions so that existing facility upgrades are prioritized. Coupling the benefits of increased thermal and visual comfort and lower incidence of toxic vectors, leading to enhanced worker productivity or domestic comfort from the passive house standard, for the housing or service sectors, may help to drive decision makers to invest in this energy efficiency standard when they look at the disposition of capital assets.

Midt-Norge som pilotregion for passivhus satsing: Potensialstudie

Bjørn Jenssen Wachenfeldt¹ og Igor Sartori²

¹ SINTEF Byggforsk, Avdeling Bygninger, 7465 Trondheim, Norge

² NTNU, Institutt for Byggekunst, Historie og Teknologi, 7491 Trondheim

Sammendrag

Ifølge Statnett er de største utfordringene for utviklingen av det sentrale kraftnettet i Norge i dag knyttet til at det forventes betydelig forbruksøkning i Midt-Norge, samtidig som det er stor usikkerhet knyttet til eventuell ny produksjon i området. Faktorer som bidrar til at forbruket øker er høy aktivitet i bygningssektoren og flere nye industriprosjekter i regionen. Dersom forbruksøkningen blir som forventet vil dette nødvendiggjøre kostnadskrevenne tiltak på forsyningsiden. Det er derfor spesielt interessant å undersøke regionale tiltak som kan bidra til at forbruksøkning begrenses eller unngås.

I denne artikkelen er det gjennomført en analyse for å undersøke i hvor stor grad en storstilt satsing på passivhus og energieffektiv rehabilitering av eksisterende boliger i Midt-Norge vil redusere det forventede kraftforbruket. Følgende scenarier frem mot år 2035 er beregnet: "Basis", "Energidirektivet", "Passivhus satsing", "Overgang til termiske energibærere", "Passivhus satsing + termiske energibærere", "Satsing på varmepumper" og "Passivhus satsing + varmepumper".

Resultatene for de ulike scenarier viser store variasjoner i forventet forbruk av elektrisitet og termiske energibærere i boligsektoren i Midt-Norge. Av de enkeltstående tiltak vurdert i denne studien er det passivhus satsingen som vil gi størst effekt både når det gjelder reduksjon av elektrisitetsforbruk og forbruk av termiske energibærere i

Midt-Norsk boligmasse. Overgang til mer bruk av termiske energibærere til oppvarming vil også bidra betydelige reduksjoner i elektrisitetsforbruket, men vil samtidig øke det totale energiforbruket. Økningen skyldes dårligere virkningsgrad for oppvarmingssystemene en ved direkte bruk av elektrisitet.

Gjennom å kombinere satsingen på passivhus teknologi med bruk av andre energibærere enn elektrisitet til oppvarming er det beregnet at elektrisitetsforbruket i Midt-Norske boliger vil reduseres fra 3,75 TWh i år 2000 til 2,74 TWh i år 2035. Dette utgjør en reduksjon på ca. 1 TWh eller 27 %. Avhengig av hva som gjøres i forhold til næringsbygg, og utviklingen i industri, transport og energisektoren, kan dette bidra til å eliminere behovet for ny kraftproduksjon i Midt-Norge og forsterkning av overføringskapasitet inn til regionen i uoverskuelig fremtid. Strategier for å bedre energiytelsen til boligsektoren bør derfor inngå som en av flere viktige elementer i Midt-Norges fremtidige energi- og miljøpolitikk.

Introduksjon

Ifølge Statnett er de største utfordringene for utviklingen av det sentrale kraftnettet i Norge i dag knyttet til betydelig forbruksøkning i Midt-Norge, samtidig som det er stor usikkerhet knyttet til eventuell ny produksjon i området. Dette vil nødvendiggjøre store investeringer på forsyningsiden. Alle tiltak som kan begrense forbruksveksten vil kunne bidra til å begrense behovet for forsterkning av overføringskapasitet og etablering av ny kraftproduksjon.

Av hensyn til miljø og samfunnsøkonomi er det derfor spesielt interessant å se på tiltak som kan begrense forbruksveksten i Midt-Norge. Denne artikkelen tar for seg potensialet for å redusere veksten i elektrisitetsforbruk og øvrig energiforbruk i Midt-Norge i forbindelse med nybygging og rehabilitering av boligene i regionen. Konsekvensene av satsing på passivhus teknologi og alternativer til elektrisitet som oppvarmingskilde er analysert spesielt.

Metode

Historisk forbruk av energivarer og aktiviteter (areal, produsert enhet e.l.) kan benyttes til å trendfremskrive den videre utvikling og på denne måten etablere et basisscenario, som igjen gir grunnlag for å vurdere andre alternative scenario.

Energibruken for de forskjellige energibærerne E_i kan uttrykkes som produktet av aktivitet (A_i) og intensitet (I_i):

$$E_i = A_i \cdot I_{ij} \quad (1)$$

der aktiviteten A_i er definert som antall m² bruksareal (BRA) for bygningstype i , mens intensiteten I_{ij} er definert som årlig mengde levert energi per m² BRA for bygningstype i og energikilde j [kWh/m²·år].

Boligmassen

Her representerer parameteren A i ligning (1) boligmassen, inkludert fritidsboliger. Den historiske utviklingen av den Norske boligmassen er tidligere analysert i forbindelse med utvikling av et nasjonalt planleggingsverktøy for energiplanlegging [i]. Flere datakilder ble analysert i forbindelse med dette arbeidet [ii,iii,iv,v].

Den historiske utviklingen av boligmassen i Midt-Norge er ikke analysert i detalj, men analyse av data fra GAB-registeret [v] viser at brutto areal av boligmassen i region Midt-Norge (Møre og Romsdal, Sør-Trøndelag og Nord-Trøndelag) i år 2005 utgjorde 11 % av boligmassens totale brutto areal i Norge. I analysene gjennomført her er det antatt at utviklingen av boligmassen i Midt-Norge etter år 2005 vil følge utviklingen i resten av landet.

Energiintensitet for en gjennomsnittsbolig

Referansenivå for *energiintensitet per bruksareal*, I , for eksisterende leiligheter og småhus er hentet fra en utredning av energimerkeordning for boliger i Norge [vi]. Energiintensitet per bruksareal for fritidsboliger er hentet fra en tidligere analyse [vii]. Behovet for levert energi til en eksisterende gjennomsnittsbolig fremkommer ved å vekte disse verdiene i forhold til deres respektive andel av boligmassen.

Når det gjelder nybygg er det i forbindelse med innførsel av energidirektivet i Norge gjennomført en revisjon av Teknisk forskrift til byggverk og produkter (TEK 97- Rev. 2007). Det er i den forbindelse etablert en ny metode for beregning av bygningers energiytelse. Metoden er dokumentert gjennom en ny norsk standard, NS3031:2007 [viii]. I den reviderte forskriften er det etablert *energirammer* som angir maksimalt tillatte netto energibehov for den aktuelle bygningstypen, beregnet etter NS3031:2007. I forbindelse med fastsettelse av energirammene er det gjennomført beregninger for typiske nye leiligheter og småhus som akkurat tilfredsstill minimumskravene [ix]. Netto spesifikt energibehov for et gjennomsnittlig ny bolig fremkommer, på samme måte som behovet for levert energi til en eksisterende gjennomsnittsbolig, ved å vekte resultatene fra disse beregningene i forhold til bygningstypenes respektive andel av boligmassen.

Tabell 1 Beregnet energibudsjett for en ny og eksisterende gjennomsnittsbolig. Tallene er per oppvarmet del av bruksareal.

Energibudsjett - gjennomsnittsbolig	Eksisterende		Ny	
	spesifikt behov for levert energi [kWh/m ² /år]	Andel av total [%]	spesifikt netto energibehov [kWh/m ² /år]	Andel av total [%]
1a Romoppvarming	135	63 %	37	30 %
1b Ventilasjonsvarme	0	0 %	6	5 %
2 Varmt vann	37	18 %	30	25 %
3 Vifter og pumper	1	0 %	8	7 %
4 Belysning	17	8 %	17	14 %
5 Teknisk utstyr	23	11 %	23	19 %
6 Kjøling	0	0 %	0	0 %
Totalt	213	100 %	121	100 %

Det resulterende behovet for levert energi til en eksisterende gjennomsnittsbolig, og netto energibehov for en ny gjennomsnittsbolig, er vist i Tabell 1. Merk at vi også har tatt hensyn til boligmassen av fritidsboliger i disse beregningene.

Energistatistikk

Data for stasjonært forbruk av energivarer for private husholdninger er gitt av energiregnskapet til SSB [x]. Statistikken gir tall på forbruket av hver enkelt energikilde.

Ved å dividere det totale forbruket på *brutto areal* av boligmassen fås *tilført energi per brutto areal* for en gjennomsnittsbolig. Denne energiintensiteten varierer noe fra år til år avhengig av en rekke parametere. Gjennomsnittlig energiintensitet i perioden 1996-2005 er beregnet til 146 kWh/m²·år.

Dette gir en omregningsfaktor fra energiintensitet per oppvarmet bruksareal (se Tabell 1) til energiintensitet per brutto areal $146/213=0,69$.

Sluttbrukerpreferanse for energikilde til oppvarming

Sluttbrukerpreferansen for energikilde til oppvarming er definert som andelen av de forskjellige energikilder som benyttes til å dekke varmebehovet, det vil si behovet for romoppvarming, oppvarming av ventilasjonsluft og tappevann. Denne preferansen vil endre seg over tid som funksjon av hvor stor andel av netto behov oppvarmingen til enhver tid utgjør, og trendutviklingen for bruk av de forskjellige energikilder. Vi har her valgt å beregne fremtidig sluttbrukerpreferanse for energibruk til oppvarming som en lineær trend basert på utviklingen fra 1996-2005, se Tabell 2. Andelen elektrisitet beregnes som det gjenværende, som betyr at trendutviklingen for elektrisitet også er helt lineær inntil all bruk av fyringsoljer i boliger er utfaset i 2034.

Tabell 2 Gjennomsnittlig sluttbrukerpreferanse for energikilde til oppvarming for periode 1996-2005, og beregnet sluttbrukerpreferanse i år 2035

År	Direkte bruk av elektrisitet	Fjernvarme	Ved	Gass	Olje	Varme fra varmepumper
2000 (1996-2005)	80,7 %	0,9 %	8,9 %	0,3 %	8,1 %	1,1 %
2035	61,8 %	2,7 %	18,7 %	2,5 %	0,0 %	14,4 %

Definisjon av arketyper

Dersom resultatene av alternative scenario skal gi nyttig informasjon bør de komme som en direkte konsekvens av reelle valg og strategier. Vi har her valgt å ta utgangspunkt i foreliggende forslag til energimerkesystem for norske boliger [vi] og benyttet det foreslåtte klassifiseringssystem som utgangspunkt såkalte arketyper. En arketype er et typebygg ment å representere en del av bygningsmassen. Arketyperne gjør det lettere å systematisere antagelsene og hypotesene rundt bygningsmassens utvikling for de forskjellige scenario som ønskes analysert.

For hver energiklasse definert i Tabell 3 er det definert egne arketyper. Arketyperne inneholder både netto energibehov og behovet for levert energi. Koblingen mellom netto og levert energi utgjøres av *sluttbrukerpreferansen av energikilde til oppvarming og systemvirkningsgraden*⁹ for de aktuelle energisystem.

Tabell 3 Foreslått kravnivå for Norsk energimerkeordning [vi].

Rr (Eng: Reference regulation)=Maksimalt tillatt netto energibehov gitt i TEK 97 – Rev. 07

Rs (Eng: Reference stock)=Behov for levert energi til en gjennomsnittsbolig

Klasse	Kravnivå
A+	$\leq 0.25 \cdot Rr$
A	$\leq 0.5 \cdot Rr$
B	$\leq 0.75 \cdot Rr$
C	$\leq Rr$
D	$\leq 0.5 \cdot (Rr + Rs)$
E	$\leq Rs$
F	$\leq 1.5 \cdot Rs$
G	$> 1.5 \cdot Rs$

Systemvirkningsgradene er hentet fra tabell B.9 og B.10 i NS3031:2007 med ett unntak: Når det gjelder vedovner angir NS3031:2007 en systemvirkningsgrad på 0,64 både for gamle og nye ovner. En systemvirkningsgrad på 0,64 forutsetter imidlertid en rentbrennende ovn, og ifølge SSB ble bare 20 % av veden brent i slike ovner i 2002 [xi]. For åpne ildsteder eller eldre vedovner som fyres med redusert lufttilførsel kan en anta en produksjonsvirkningsgrad på 0,4. Med en reguleringsvirkningsgrad på 0,8 gir dette en systemvirkningsgrad på 0,36. Med dette som utgangspunkt er gjennomsnittlig systemvirkningsgrad i eksisterende boliger i år 2000 anslått til 0,42. Systemvirkningsgradene benyttet i analysene er gitt i Tabell 4. Arketypernes struktur er illustrert i for arketyper slik illustrert i Tabell 5.

Tabell 4 Systemvirkningsgrader benyttet i analysene

direkte bruk av elektrisitet	oppvarming					
	olje	gass	ved	fjernvarme	elektrisitet	varme fra varmpumpe
1.00	0.72/0.77 ^a	0.77 / 0.81 ^a	0.42 / 0.64 ^a	0.86/0.88 ^a	1.00	2.16

^a Verdien til venstre representerer oppvarmingssystemer eldre enn 1990, og er anvendt for eksisterende bygninger, mens verdien til høyre representerer nye oppvarmingssystemer, og er anvendt for rehabiliterte eller nye bygninger

⁹ Systemvirkningsgraden er gitt av produktet av produksjonsvirkningsgraden, distribusjonsvirkningsgraden og reguleringsvirkningsgraden, $\eta_{\text{system}} = \eta_{\text{produksjon}} \cdot \eta_{\text{distribusjon}} \cdot \eta_{\text{regulering}}$

Tabell 5 Strukturen til arketyperne

Arketype XY: Energiklasse X, Sluttbrukerpreferanse Y for energikilde til oppvarming				
Netto energi			Levert energi	
netto behov	[kWh/m ² år]			energibærer
total Netto			total Levert	
elspesifikt behov	x1	" → sluttbrukerpreferanse for energikilde til oppvarming og systemvirkningsgrad for oppvarmings/kjølesystem → "	elektrisitet	y1
kjøling	x2		fjernvarme	y2
varme	x3		ved	y3
			gass	y4
			olje	y5
			omgivelsesvarme via varmepumpe	(y0)
Avhenger av energiklasse			Avhenger av systemvirkningsgrad og sluttbrukerpreferanse	

I tillegg til at hver energiklasse har sine arketyper er det definert egne arketyper for startåret (år 2000) og sluttåret (år 2035) for analysene. Forskjellen mellom startåret og sluttåret er at *sluttbrukerpreferansen for energikilden til oppvarming* og *systemvirkningsgraden* for oppvarmingssystemene har endret seg slik det fremgår av henholdsvis Tabell 2 og Tabell 4. Figur 0-1 viser arketyperne som representerer en gjennomsnittsbolig (*Energiklasse E = Rs – se Tabell 3*) i henholdsvis år 2000 (øverst) og år 2035 (nederst). Som vi ser er netto tallene like for de to arketyperne ettersom de representerer samme energiklasse, mens tallene for levert energi er forskjellige som følge av forskjellig sluttbrukerpreferanse for energikilde til oppvarming (se Tabell 2) og systemvirkningsgrad (se Tabell 4). Legg også merke til at tallene for gjennomsnittsboligen anno år 2000 stemmer overens med tallene i Tabell 1.

Med utgangspunkt dataene fra Tabell 1, Tabell 2 og Tabell 3 er det etablert tilsvarende arketyper for de øvrige energiklasser for år 2000 og år 2035.

Energiklasse E (Rs) år 2000											
netto energi						levert energi					
energibehov	kWh/m ² /år	andel	energibærer	sluttbruker- preferanse	kWh/m ² /år	system- virkningsgrad	energibærer	kWh/m ² /år	energibærer	kWh/m ² /år	andel
	190,0									213,0	
elspesifikt	41,0	21,6 %				1,00	elektrisitet	41,0	elektrisitet	162,1	76,1 %
kjøling	0,0	0,0 %				1,40	elektrisitet	0,0			
oppvarming	149,0	78,4 %	direkte bruk av			direkte bruk av					
			elektrisitet	80,7 %	120,3	1,00	elektrisitet	120,3			
			fjernvarme	0,9 %	1,4	0,86	fjernvarme	1,6	fjernvarme	1,6	0,7 %
			ved	9,3 %	13,9	0,42	ved	33,1	ved	33,1	15,5 %
			gass	0,3 %	0,4	0,77	gass	0,6	gass	0,6	0,3 %
			olje	7,6 %	11,3	0,72	olje	15,7	olje	15,7	7,4 %
			varme fra VP	1,1 %	1,7	2,16	elektrisitet til drift av VP	0,8			
						omgivelsesvarme via VP	0,9	omgivelsesvarme via VP	0,9	---	

Energiklasse E (Rs) år 2035											
netto energi						levert energi					
energibehov	kWh/m ² /år	andel	energibærer	sluttbruker- preferanse	kWh/m ² /år	system- virkningsgrad	energibærer	kWh/m ² /år	energibærer	kWh/m ² /år	andel
	190,0									196,2	
elspesifikt	41,0	21,6 %				1,00	elektrisitet	41,0	elektrisitet	142,0	72,4 %
kjøling	0,0	0,0 %				1,40	elektrisitet	0,0			
oppvarming	149,0	78,4 %	direkte bruk av			direkte bruk av					
			elektrisitet	61,1 %	91,0	1,00	elektrisitet	91,0			
			fjernvarme	2,6 %	3,9	0,88	fjernvarme	4,4	fjernvarme	4,4	2,3 %
			ved	19,5 %	29,1	0,64	ved	45,5	ved	45,5	23,2 %
			gass	2,3 %	3,5	0,81	gass	4,3	gass	4,3	2,2 %
			olje	0,0 %	0,0	0,77	olje	0,0	olje	0,0	0,0 %
			varme fra VP	14,4 %	21,5	2,16	elektrisitet til drift av VP	10,0			
						omgivelsesvarme via VP	11,5	omgivelsesvarme via VP	11,5	---	

Figur 0-1 Arketype for en gjennomsnittsbolig (Energiklasse E = Rs) i henholdsvis år 2000 (øverst) og år 2035 (nederst)

Forutsetninger for energiscenariene

Hensikten med scenariene er primært å undersøke konsekvensene av en aktiv satsing på passivhus-teknologi, både for nye boliger og ved rehabilitering av eksisterende boliger. I alle scenarier forutsetter vi imidlertid at netto spesifikt energibehov ikke endres for eksisterende bygg som ikke rehabiliteres. Dette betyr at bygg som ikke rehabiliteres beholder samme energiklasse gjennom hele den analyserte perioden. Det eneste som endres for disse byggene er *sluttbrukerpreferansen for energikilde til oppvarming*, som gradvis nærmer seg 2035-nivå i henhold til Tabell 2. Dette betyr i praksis at andelen av varmebehovet som dekkes av ved, omgivelsesvarme via varmepumper, fjernvarme og gass gradvis øker for disse boligene, mens andelen olje og elektrisitet gradvis reduseres.

Aktivitet innen nybygg og rehabilitering

For å beregne aktivitet innen rivning, nybygg og rehabilitering er det utviklet en dynamisk metode som er anvendt på den norske boligmassen [xii]. Vi har benyttet samme metode på boligmassen i Midt-Norge.

I [xii] er det konstruert tre scenarier, et "low" et "medium" og et "high". Her har vi tatt utgangspunkt i input parameterne benyttet i "medium"-scenariet. Dette innebærer en antatt gjennomsnittlig levetid for byggene på 100 år, et gjennomsnittlig rehabiliteringsintervall på 40 år, en lineær økning i folketallet frem mot år 2035 samt en utflating i antall personer per boenhet og antall m² bruksareal per boenhet.

Det resulterende aktivitetsnivå innen rehabilitering, nybygging og rivning, samt beregnet utvikling i total boligmasse i Midt-Norge er vist i Figur 0-2. Legg merke til at i motsetning til tidligere forventes antall rehabiliterte kvadratmeter boligareal overstige antall kvadratmeter nybygd areal de neste 30 år.

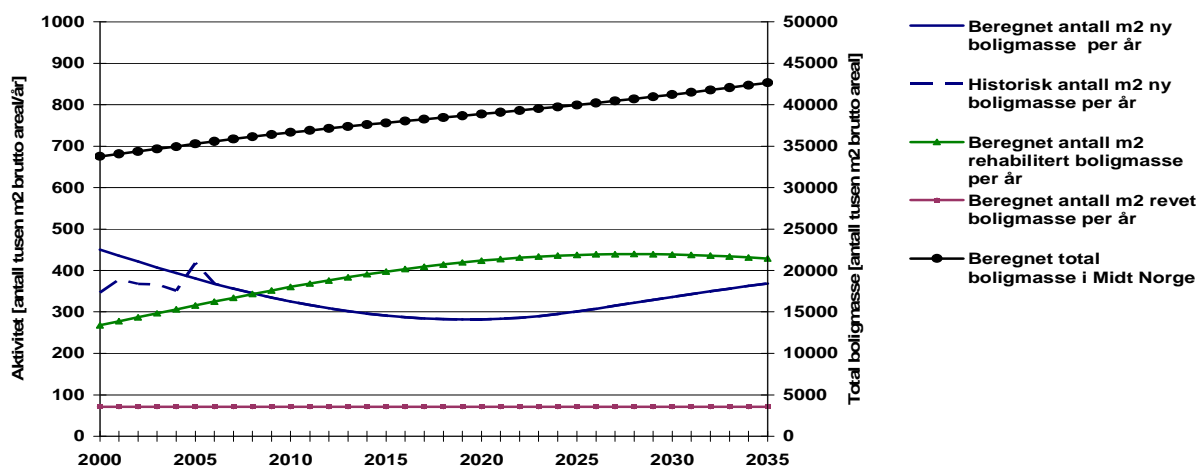

Figur 0-2 På venstre akse er beregnet aktivitetsnivå i Midt-Norge angitt i antall tusen m²brutto boligareal/år for henholdsvis nybygg (blå kurve), rehabilitering (grønn kurve) og rivning (plummefarget linje). På høyre akse er den totale boligmassen angitt i antall tusen m²brutto areal (sort linje)

Forutsetning med hensyn til energiklasse og sluttbrukerpreferanse

Med utgangspunkt i energiklassene definert i Tabell 3 gjelder følgende antagelser for alle scenarier:

- Eksisterende boliger som ikke rehabiliteres beholder energiklasse E i hele perioden, mens sluttbrukerpreferansen for energikilde til oppvarming endres gradvis fra 2000-nivå til 2035 nivå i henhold til Tabell 2.
- Boliger som rives har samme energiklasse som eksisterende boliger som ikke rehabiliteres (energi klasse E) og den sluttbrukerpreferanse for energikilde til oppvarming som gjelder på rivningstidspunktet.
- Boliger som bygges fra år 2000 til år 2009 antas få energiklasse D mens sluttbrukerpreferanse for energikilde til oppvarming endres gradvis mot 2035 nivå i henhold til Tabell 2.
- Rehabilitering av eksisterende boliger fra år 2000 til år 2009 påvirker ikke boligens energiklasse, mens sluttbrukerpreferansen for energikilde til oppvarming endres gradvis mot 2035 nivå i henhold til Tabell 2.

Det er så etablert seks scenarier med ulike forutsetninger:

Basis (business as usual)

Samme antagelser som over for hele perioden:

- Nybygg får energiklasse D
- Rehabilitering påvirker ikke energiklasse
- Sluttbrukerpreferansen for energikilde til oppvarming antas endres gradvis mot 2035 nivå i henhold til Tabell 2 både for uforandrede, rehabiliterte og nye bygg.

Energidirektivet

For dette scenariet antas de nye kravene i den reviderte TEK (TEK 97 – Rev. 2007) blir etterfulgt slik at:

- Alle nye boliger bygget i år 2010 eller senere får energiklasse C
- Rehabilitering medfører fra og med år 2010 en oppgradering fra energiklasse E til energiklasse D.
- Samme antagelse som for basis scenariet med hensyn til sluttbrukerpreferansen for energikilde til oppvarming.

Passivhus satsing

- Nybygg forbedres gradvis fra klasse C i 2010 til klasse A+ i år 2015.
- Rehabilitering medfører også en gradvis forbedring fra energiklasse D i år 2010 til energiklasse A i år 2020.
- Samme antagelse som for basis scenariet med hensyn til sluttbrukerpreferansen for energikilde til oppvarming.

Overgang til termiske energibærere

- Samme forutsetninger som basis scenariet med hensyn til energiklasse
- Sluttbrukerpreferansen for energikilde til oppvarming følger samme utvikling som for basis scenariet frem til år 2010. Fra år 2010 skjer det en gradvis overgang til en situasjon der sluttbrukerpreferansen for bruk av elektrisitet til oppvarming i 2035 er redusert til 25 % for alle nye og rehabiliterte boliger. For beregning av en gjennomsnittlig systemvirkningsgrad for de termiske energibærerne er det antatt at øvrig oppvarming dekkes med en like stor andel gass, fjernvarme og ved.

Satsing på varmepumper

- Samme forutsetninger som basis scenariet med hensyn til energiklasse
- Sluttbrukerpreferansen for energikilde til oppvarming følger samme utvikling som for basis scenariet frem til år 2010. Fra år 2010 skjer det en gradvis overgang til en situasjon der varmen fra varmepumper dekker 50 % av det totale oppvarmingsbehovet i rehabiliterte og nye boliger i år 2035.

Passivhus satsing + termiske energibærere

- Samme forutsetninger med hensyn til energiklasse som scenario "Passivhus satsing"
- Samme forutsetninger med hensyn til sluttbrukerpreferanse for energikilde til oppvarming som scenario "Overgang til termiske energibærere".

Passivhus satsing + varmepumper

- Samme forutsetninger med hensyn til energiklasse som scenario "Passivhus-satsing"
- Samme forutsetninger med hensyn til sluttbrukerpreferanse for energikilde til oppvarming som scenario "Satsing på varmepumper"

Resultater

Figur 0-3 gir en oversikt over historisk forbruk og beregnet fremtidig levert energi til boligene i Midt-Norge for de forskjellige scenario. Total levert energi er summen av levert elektrisitet i gult og termiske energibærere i blått. Beregnet omgivelsesvarme tilført via varmepumper er også vist. Denne “gratisvarmen” er ikke inkludert i levert energi, men kommer som et tillegg. Resultatene er oppsummert i Tabell 6.

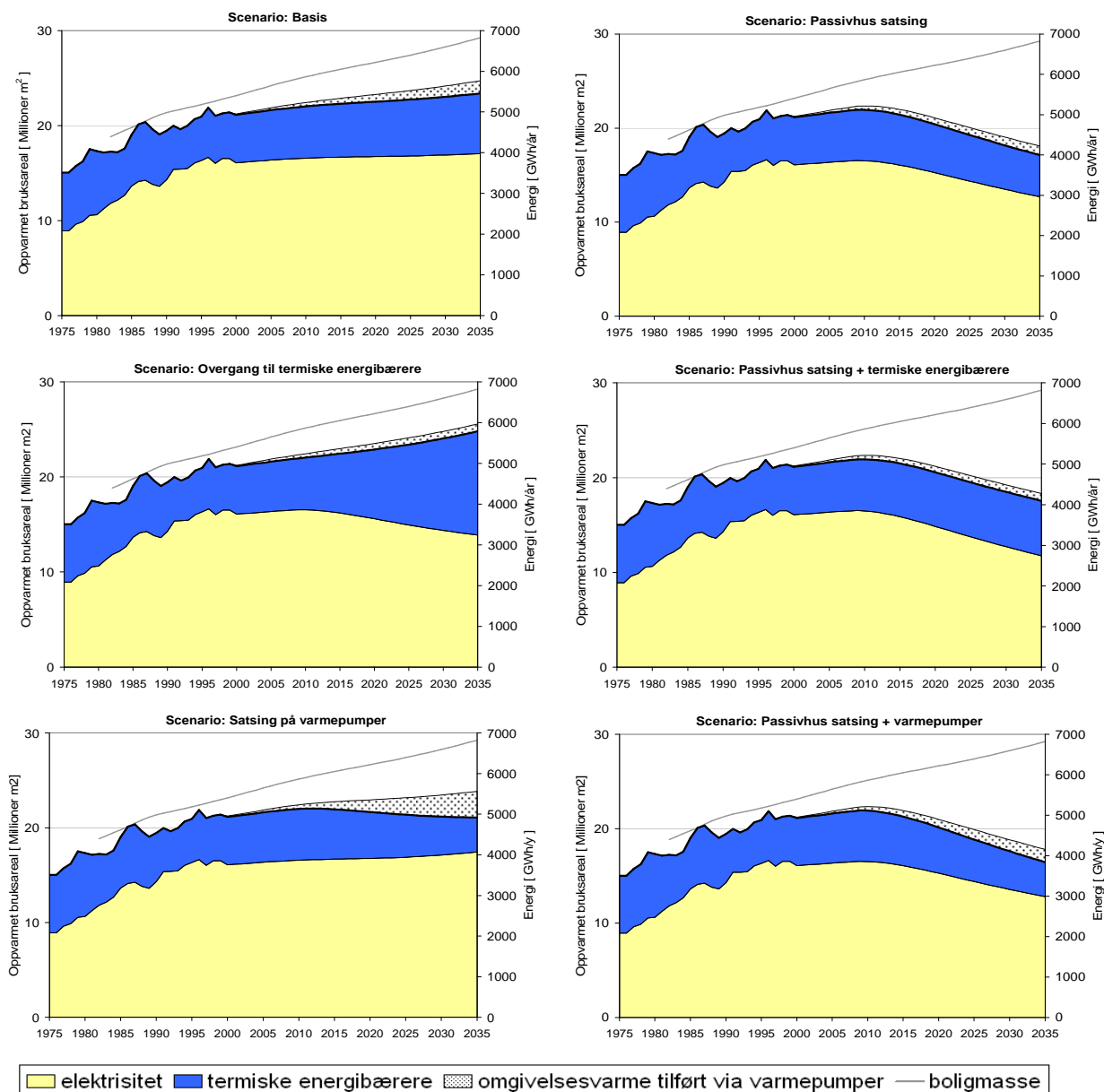

Figur 0-3 Historisk forbruk og beregnet fremtidig levert energi til boligene i Midt-Norge for “basis – scenariet” (øverst til venstre) passivhus satsing (øverst til høyre), overgang til termiske energibærere (midten til venstre), passivhus satsing + overgang til termiske energibærere (midten til høyre), satsing på varmepumper (nederst til venstre), passivhus satsing + varmepumper (nederst til høyre). Venstre y-akse viser oppvarmet bruksareal i millioner m^2 , mens høyre y-akse viser totalt antall GWh/år.

Tabell 6 Oppsummering av resultater for de analyserte scenariene

Scenario	Levert energi i år 2035 [GWh/år]					
	Totalt	Elektrisitet	Termiske energibærere	Uforandrede boliger	Rehabiliterede boliger	Nye boliger
År 2000 referanse	4.926	3.748	1.178			
Basis	5.449	3.973	1.476	2.358	1.843	1.249
Overgang til termiske energibærere	5.780	3.235	2.545	2.358	2.055	1.367
Satsing på varmepumper	4.914	4.066	848	2.358	1.498	1.058
Passivhus satsing	3.993	2.958	1.036	2.358	984	651
Passivhus satsing + termiske energibærere.	4.092	2.737	1.355	2.358	1.057	678
Passivhus satsing + varmepumper	3.833	2.986	848	2.358	867	609
Energidirektivet	4.980	3.684	1.296	2.358	1.574	1.049

Konklusjoner

Det er beregnet at om vi fortsetter å bygge- og rehabiliterer boliger som før vil elektrisitetsforbruket til boligene i Midt-Norge øke fra 3748 GWh i år 2000 til 3973 GWh i år 2035. Det vil si en økning på 225 GWh/år eller 6 %. Bruken av termiske energibærere (andre energibærere enn elektrisitet) er samtidig beregnet å øke med 298 GWh/år (25 %) fra 1178 GWh i år 2000 til 1476 GWh i år 2035.

Av tiltakene vurdert i denne studien er passivhus satsingen det som vil gi størst effekt både når det gjelder reduksjon av behov for elektrisitet og termisk energi i Midt-Norsk boligmasse. Dersom det lykkes å få til en gradvis endring fra dagens energistandard for boligene som bygges og rehabiliteres slik at alle nye boliger som bygges etter 2015 får passivhus standard (energimerke A+), mens alle boliger som rehabiliteres etter år 2020 oppgraderes til god lavenergistandard (energimerke A), er det beregnet at dette vil redusere det totale elektrisitetsforbruket i

Midt-Norske boliger fra 3748 GWh i år 2000 til 2958 GWh/år i år 2035, det vil si en reduksjon på 790 GWh/år eller 21 %. Samtidig er forbruket av termiske energibærere beregnet å reduseres med 142 GWh/år (12 %) fra 1178 GWh i år 2000 til 1036 GWh i år 2035.

Satsing på passivhus i kombinert med varmepumper er til sammenligning beregnet å redusere elektrisitetsforbruket med 763 GWh/år (20 %) fra år 2000 til år 2035, mens reduksjonen i bruk av termiske energibærere da blir 330 GWh/år (30 %). Dette innebærer at varmepumpe satsingen vil bidra til en marginal økning av elektrisitetsforbruket, men vil til gjengjeld medføre en betydelig reduksjon i bruken av andre energibærere.

En omfattende omlegging fra bruk av elektrisitet til mer bruk av termiske energibærere til oppvarming er tilsvarende beregnet å bidra til en reduksjon på 513 GWh/år (14 %) med elektrisitet fra år 2000 til år 2035, men vil samtidig øke forbruket av termiske energibærere med hele 1367 GWh/år (116 %). Dette vil måtte medføre betydelige tiltak på forsyningsiden i forhold til produksjon og distribusjon av termiske energibærere.

En kombinasjon av passivhus satsing og bruk av termiske energibærere er beregnet å redusere elektrisitetsforbruket med 1011 GWh/år (27 %) fra år 2000 til år 2035, mens forbruket av termiske energibærere er beregnet å øke med 178 GWh/år (11 %). Dette er følgelig den strategien som har størst potensial i forhold til

å redusere elektrisitetsforbruket i Midt-Norsk boligmasse. Samtidig gir den en økning av det termiske energibehovet er så liten at dette ikke vil medføre drastiske tiltak i forhold til termisk energiforsyning.

Forutsatt at de skjerpede energikrav i TEK 07 – Rev 07 som følge av *Energidirektivet* blir etterfulgt er det estimert at elektrisitetsforbruket til boligmassen i Midt-Norge vil reduseres med 64 GWh/år (2 %) fra år 2000 til år 2035, mens det termiske forbruket er beregnet å øke med 119 GWh/år (10 %).

En storstilt satsing på passivhus teknologi, gjerne i kombinasjon med bruk av andre energibærere enn elektrisitet til oppvarming, vil redusere behovet for etablering av ny kraftproduksjon og forsterkning av overføringskapasitet inn til Midt-Norge. Avhengig av hva som gjøres i forhold til næringsbygg, og utviklingen i industri, transport og energisektoren, kan dette bidra til å eliminere behovet for ny kraftproduksjon i Midt-Norge og forsterkning av overføringskapasitet inn til regionen i uoverskuelig fremtid. Strategier for å bedre energiytelsen til boligsektoren bør derfor inngå som en av flere viktige elementer i Midt-Norges fremtidige energi- og miljøpolitikk.

Referanser

-
- [i] Igor Sartori and Bjørn J. Wachenfeldt (2006), *ePlan 2006 – Final report*, ISBN 978-82-536-0947-8
- [ii] Folke og boligtellingsen 1980, 1990 og 2001, Statistisk Sentralbyrå.
- [iii] Boforholdsundersøkelsen 1973, 1981, 1988, 1995, 1997, 2001 og 2004, Statistisk Sentralbyrå.
- [iv] Lars Myhre (2000), *Towards Sustainability in the Residential Sector- A Study of Future Energy Use in the Norwegian Dwelling Stock*, Byggforsk Note 41, 2000, ISBN 82-536-0697-4
- [v] Grunneiendom-, Adresse- og Bygningsregisteret (GAB), Statens Kartverk
- [vi] Trine D. Petersen, Lars Myhre, Tore Wigenstad, Tor H. Dokka (2005), *Oppdragsrapport Energimerking av boliger*, O 20461 (kan lastes ned fra <http://www.bygningsenergidirektivet.no/>)
- [vii] Bjørn Jenssen Wachenfeldt (2004) *A spreadsheet tool for scenario analysis of the energy consumption in buildings and resulting emissions (developed within the TRANSES project)*, Project Memo, SINTEF Civil and Environmental Engineering, Architecture and Building Technology
- [viii] Standard Norge (2007), *NS 2021:2007 Beregning av bygningers energiytelse. Metode og data*, ICS 900.08.21;91.120.10
- [ix] Marit Thyholt, Tor Helge Dokka, Sivert Ulsløkk, Arild Gustavsen (2007), *Nye energikrav i tekniske forskrifter – Utredninger Høsten 2006*, Sintef Byggforsk rapport SBF BY A07002
- [x] Statistisk Sentralbyrå (SSB) – *Energiregnskapet; Oed 1976-2005 PJ.xls*, Oppdatert 4.5.2007
- [xi] Kristin Aasestad (2007) *Vedfyring og utslipp til luft. Foreløpige landstall boliger 2006*, SSB Artikkel 27.7.2007
- [xii] I Sartori, H Bergsdal and H Brattebø, *Construction, renovation, and demolition activities modelling: example of the Norwegian dwelling stock*, Accepted for publication in *Building Research and Information* provided minor revisions and amendments (Editor's Reference Number: BR6302)

Session 4

Experiences from design and construction of passive houses

Olav Langenkamp The first certified passive house in Denmark.....	94
Maria Wall, Ulla Janson Apartment buildings as passive houses in Värnamo, Sweden	97
Bengt Michalsen, Georg Orvedal Planlegging og bygging av passivhus i Lierbyen, Lier Kommune	103
Michael Klinski; Lars K. Halleraker, Harald Ringstad Det første sertifiserte passivhus i Norge.....	111
Petra Vladykova, Carsten Rode, Toke Rammer Nielsen, Søren Pedersen Passive Houses for Arctic Climates	118

The first certified passive house in Denmark

Olav Langenkamp, Architect ETH-MAA, www.langenkamp.dk, ol@aa-a.dk

Villa Langenkamp, Ebeltoft, Denmark, 147 sq.m. passive house; 45 sq.m. garage, technical room and entrance constructed to normal building standards.

The project

The planning and design of the house started in 2006, and it took some time before the final shape was established. It is one of the most difficult tasks in the life of an architect to design his own house. It had to be a passive house. The requirements were: three bedrooms, two bathrooms, one office/library, a living/dining room and a kitchen.

The building regulations did not permit a design with a full second floor. The angle of the roof had to be between 45 and 0 degrees. After several sketches with a 45-degree roof, I decided to design a passive house on one floor. Unfortunately, there are very few single-storey passive houses in Europe. This presented a considerable challenge. The insulation had to be very thick in order to compensate for the bigger external surface area. Furthermore, the house is oriented towards the south-west and not directly towards the south. It took several months to choose the right windows, ventilation system etc in order to achieve the passive house standard. Architectural and technical decisions were accompanied by PHHP calculations.

The design

Less is more! After several months of designing and redesigning the house, I finally reached the point where the design phase was completed. A simple black box designed around a living and dining room. Nothing more! The kitchen and bathrooms are grouped in order to minimise water pipelines through the house. A “thick” wall between the living room and the bedrooms houses a wardrobe and a “hot air supply”.



South-west elevation

The contractor

Who can build a passive house in Denmark for a reasonable price? I found the answer to this question on the German side of the Danish border! After several meetings with Danish and German contractors, I decided to build the house using a German contractor with passive house experience who was able to build the house in elements. Excavation, plumbing, electrical installations and water supply had to be carried out by authorised Danish contractors. All passive house elements as well as the entire passive house ventilation system came from Germany and were assembled and fitted by German contractors. The coordination between several Danish and German firms was one of the most time-consuming aspects of the project.



South-west elevation

Construction phase

Excavation started on 1 September 2007. The wood elements arrived on 1 October. All internal and external walls as well as the roof elements were erected after only four days. Windows arrived two weeks later. Internal finishing, ventilation, plumbing and electrical installations were completed in the following months. The house was totally finished by mid-February after a five-month construction period.

Next step

In collaboration with a Danish electricity supplier, an energy monitoring programme was implemented. Six additional kW measuring devices were connected to a server in order to monitor the precise energy consumption and efficiency of each technical component.



South-east elevation with passive solar façade



South-west elevation with terrace

Goal

It is possible to build passive houses in Denmark at a reasonable price! This house is a very good example that the passive house standard is achievable, also in Denmark. There was enormous media interest in the house: Newspaper articles, features in architectural magazines, as well as radio and TV programmes. Potential clients are calling and writing, asking for more information about passive houses, and the second passive house in Denmark is already on the way. It's never too late to start saving energy!

Apartment buildings as passive houses in Värnamo, Sweden

Maria Wall and Ulla Janson

Division of Energy and Building Design, Dept of Architecture and Built Environment, Lund University.
P.O. Box 118, SE-221 00 Lund, Sweden.

Introduction

In the centre of Värnamo in the southern part of Sweden (latitude 57°12'12 N), five buildings with 40 rental apartments were built according to the passive house standard and are part of the public housing sector. Värnamo is a small town that is slowly growing, and these apartments are part of the local municipality's plan of expansion. The buildings were finalized in the summer 2006 (Figure 1).



Figure 1 The apartment buildings in Värnamo, Sweden.

The apartment buildings are owned by the public housing company Finnvedsbostäder. Two of the buildings are in two storeys and three buildings are in two-and-a-half storeys. The apartments have two to five rooms with either a balcony or with a patio on the ground floor. This building project is a case study within a research project carried out at the Division of Energy and Building Design, Lund University, to analyse energy aspects of passive houses in Sweden. The research is funded by the Swedish Energy Agency and is based on earlier research carried out for e.g. the first Swedish passive houses in Lindås [Wall 2006]. Experiences from the Lindås project were also used when designing the passive houses in Värnamo. Additional information about the project in Värnamo and other passive house projects can be found in [Janson 2008].

Building constructions and mechanical systems

The loadbearing structure is made of concrete and cast on site. The external wooden frame walls were also mounted on site. The buildings are highly insulated. U-values for the building envelope are shown in Table 1. The part of the floor facing ground right under the apartment walls has a total U-value of 0.15 W/m²K excluding ground. The entry door was designed by Finnvedsbostäder and produced at one of the largest Swedish door companies since it was hard to find entry doors with low U-values.

Building envelope	U-value (W/m ² K)
Ground floor (excluding ground)	0.09
Exterior walls	0.10
Roof	0.07
Windows, average	0.94
Door	0.60

Table 1 U-values of the building envelope parts

Every apartment has its own mechanical ventilation system with an air-to-air heat exchanger. The ventilation unit is placed in a closet to minimize internally generated sound. Additional heat is supplied by electric resistance heating in the supply air during cold days. The power of the battery is 0.9 kW or 1.8 kW depending on the size of the apartment ($14.5 \text{ W/m}^2 - 16.8 \text{ W/m}^2$). According to the producer, the heat exchanger has an efficiency of 85%. To make sure that no noise will be generated, two silencers are mounted on the supply air system, right after the heat exchanger unit. On the exhaust air duct, one silencer is mounted.

All five buildings have solar collectors on the roof connected to a central room for domestic hot water production, one in each building. There are 25 m^2 of solar collectors on each building. The solar fraction is assumed to be 50%. Additional heat for domestic hot water is supplied from an electric battery in the accumulator tank. The housing company Finnvedsbostäder owns part of a wind power plant and uses wind generated electricity for these buildings.

Design and construction stage

During the design stage, energy simulations were carried out by the energy consultant in order to estimate the energy demand. Within our research project, additional simulations were carried out regarding energy demand and indoor temperatures. The energy demand and the peak load for space heating were calculated in DEROB-LTH. With an indoor temperature of 20°C the peak load for space heating was calculated to 8.3 W/m^2 . The space heating demand was calculated to $9.8 \text{ kWh/m}^2\text{a}$.

In September 2005, before the major work started on site, everyone involved were gathered for an afternoon of education. The standard of passive houses and the importance of airtightness were discussed. Real models of the wall and roof constructions were placed at the working area and discussed (Figure 2 and 3).



Figure 2 Roof construction.



Figure 3 Wall and ground construction.

It is important to keep the construction airtight and dry. An installation layer where there is a distance between the wall and the plastic foil, makes it easy to avoid damage to the plastic sheet when mounting pipes and electrical equipment. To protect the wooden construction from the moisture in the concrete slab, there is a metal sheet placed on the concrete slab that breaks the capillary suction. A small spacer block made of plastic is also

put under the wooden beam for additional moisture reduction. The steel strip construction has been tested to make sure it will not cause a thermal bridge (Figure 4).

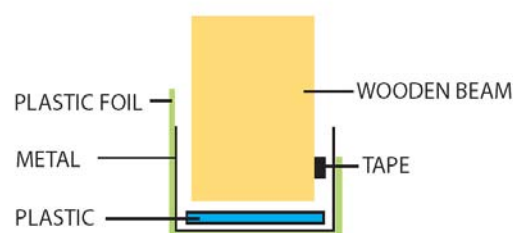

Figure 4 Protection of wooden construction.

Sound measurements

Measurement of sound produced by the ventilation unit and transported in the ventilation system has been made in a four room apartment. Results are shown in Table 2. The ventilation unit is placed in a closet close to the entrance of the apartment. To increase the accessibility of the closet, the doorstep between the hallway and the closet is taken away. This can signify some noise leaking from the ventilation unit in to the hallway and explain the higher sound level in the hallway resulting from this.

Room:	Measured sound level (dB(A))	Maximum allowed sound level (dB(A))
Bedrooms, living room	19.0, 19.0, 22.8 and 23.0	26
Kitchen	26.9	35
Bathrooms	31.4 and 34.9	35
Hallway	35.1	35

Table 2 Measured sound levels in one four room apartment, and required levels.

Airtightness measurements

Everyone working in the project, from consultants to the plumber, was aware of the specification of requirements and was thinking about airtightness and quality issues at all times. To keep a good feeling of teamwork, every Friday a meeting was held on site. The work done during the week was discussed, also if new solutions had been found or if problems had occurred. The contractors say that these meetings have given a great feeling that each carpenter's achievements really count; a feeling of importance. This also makes the people involved in the project proud of the result and they all delivered the project to the client with really straight backs.

The airtightness requirements was set to maximum 0.4 l/s,m² at 50 Pa. The contractor was not sure they would be able to achieve such airtight buildings since they did not have any experience in doing this before. The contractor therefore measured the airtightness in one apartment at an early stage in order to check if they used the right method to reach the airtightness required. The final measurements showed an average airtightness of 0.2 l/s,m² at 50 Pa which is very good. The measurements were carried out without differential pressure across apartments, thus the results represent the average for the building envelope and areas between apartments.

Costs

The calculated total cost for the client was SEK 50 243 000. The purchased total cost was SEK 52 300 000. The final cost for the client was SEK 55 700 000. The gross amount per square meter, subsidies not subtracted, ended up at SEK 17 898 /m². The total cost for the contractor was SEK 36 700 000, VAT not included; approximately SEK 11 800 /m². In these prices, the cost of the piece of land is included as well as costs for electricity- and water connections. The client estimates that for building a regular house just meeting the building code requirements, the cost would probably be around SEK 15 000 /m². Two years earlier, the client built similar apartments, not to passive house standard. The cost of building these apartments was approximately SEK 13 000 /m².

The difference between the cost for the client and the cost for the contractor shows that there is a large cost for the design stage. Since the planning first started with regular houses and then had to be modified to passive houses, the first documents used in the process for building permission had to be drawn up twice.

The client has, after a close evaluation of the project, decided to continue with passive houses and is now planning for new multifamily houses with 50 apartments built to passive house standard.

Measurements during occupancy stage

The use of household electricity and domestic hot water is closely measured by the client. Every month the tenants' use of electricity and domestic hot water is shown on the rental notification, together with the cost. This makes it easy for the tenants to have an influence on both the use and the costs of the electricity and domestic hot water. The tenants pay SEK 1.20 per kWh for household electricity; this includes the fixed costs. There is a large cost saving potential for the tenants by reducing the electricity use.

In order to evaluate this demonstration project, additional measurements are carried out. In eight apartments (one of the buildings) the indoor temperature, outdoor temperature, total electricity use and the use of electrical power to the heating battery are also measured by the client.

Measurements from the first year of occupancy show that the delivered (bought) energy demand was 67 kWh/m²a as an average for the five buildings. Figure 5 shows the energy demand for the passive houses (Oxtorget) compared with another area of apartment buildings in Värnamo (Apollofjärilen) built 2004 according to the Swedish Building Code standard. The measurements are from the same period of time and can therefore be directly compared. The measurement results are not adjusted to a normal climatic year. The delivered (bought) energy demand for the passive houses was approximately 44% of the energy demand for the standard buildings. The contribution from the solar collectors in the passive houses was approximately 10 kWh/m²a during this first year. The total energy demand for Oxtorget was therefore 77 kWh/m²a.

The standard buildings (Apollofjärilen) that are used as comparison have in fact a relatively low energy demand (151 kWh/m²a). The energy demand for domestic hot water and space heating and electricity for mechanical systems are in Apollofjärilen (built 2004) lower than required in the new Swedish Building Code from 2006. Another area with apartment buildings measured in Värnamo used approximately 220 kWh/m²a during the same period.

Note that the household electricity for Oxtorget includes the space heating demand (Figure 5). Even so, the household electricity is somewhat lower than for Apollofjärilen. Further analyses will be carried out in order to clarify the energy use for different parts more in detail.

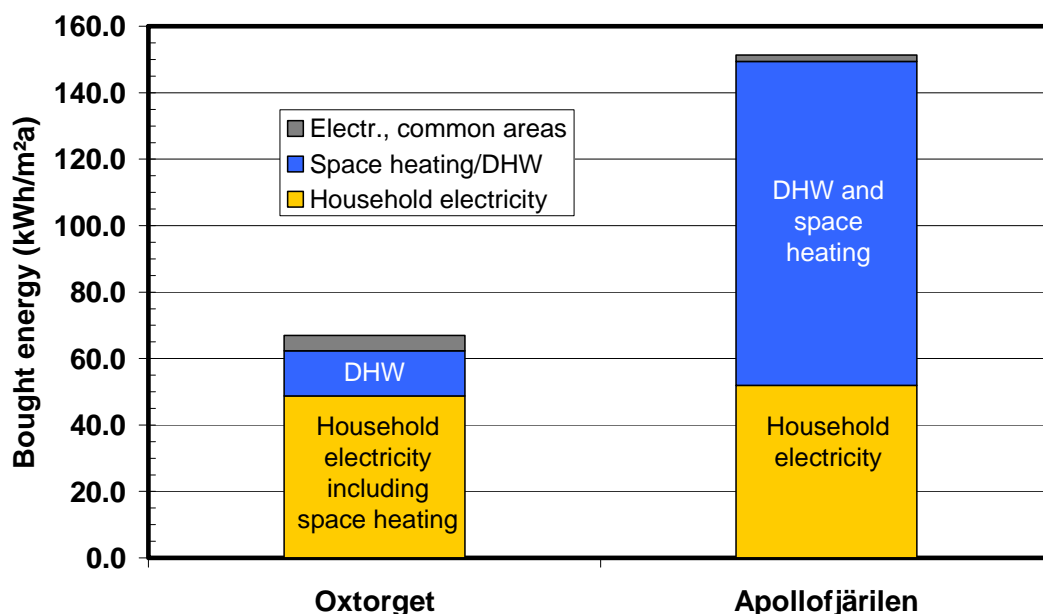

Figure 5 The delivered (bought) energy demand in the passive houses in Värnamo (Oxtorget) compared with standard apartment buildings (Apollofjärilen), also in Värnamo. Measurements from Finnvedsbostäder during September 2006 – August 2007. This was the first year of occupancy for Oxtorget.

The domestic hot water use was also measured in the two projects. The results show that the DHW used was 28% lower in the passive houses compared to the standard buildings (Figure 6). This of course also results in a lower energy demand for DHW for the passive houses. In Oxtorget, energy saving mixer taps are used. The mixer taps have reduced water flow if not pressed further upwards. Also, they give only hot water if pressed all the way out to the left.

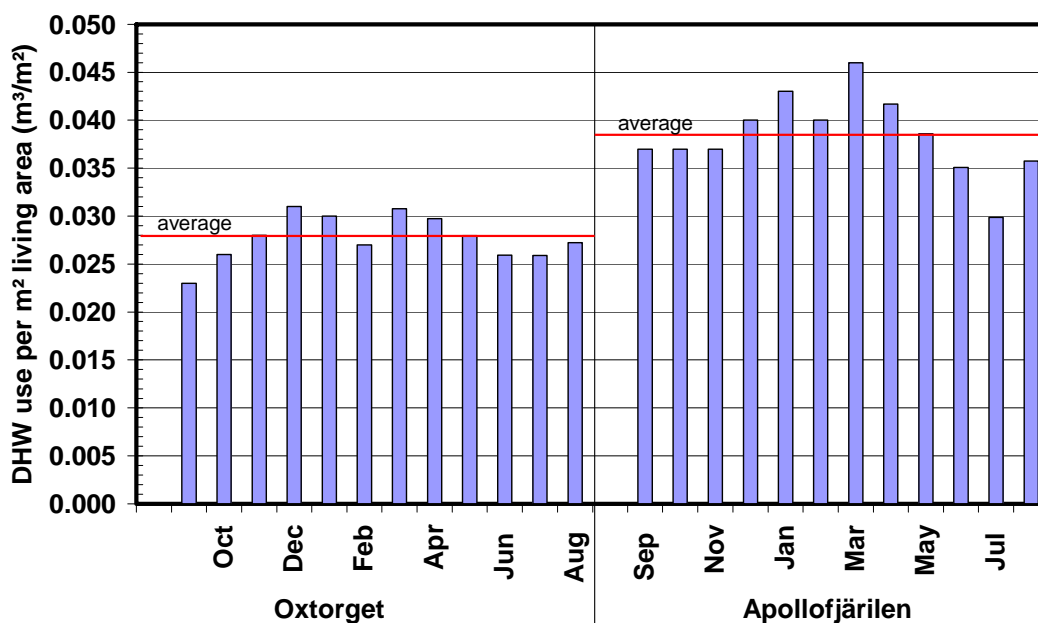

Figure 6 The domestic hot water use in the passive houses in Värnamo (Oxtorget) compared with standard apartment buildings (Apollofjärilen), also in Värnamo. Measurements from Finnvedsbostäder September 2006 – August 2007.

Conclusions and further work

During the construction stage, the requirements, such as for the airtightness and sound levels from the ventilation system, were achieved. The first results from energy measurements show that the passive houses are very energy-efficient. The measurements will be further analysed within our ongoing research project to see if the buildings will meet all the requirements. The results will also be compared with measurements in other passive house projects. Interviews with the occupants will show how they experience to live in a passive house and if improvements need to be done in future projects.

References

[Janson 2008] Janson, Ulla, *Passive houses in Sweden. Experiences from design and construction phase*. Licentiate thesis. Report EBD-T--08/9, Energy and Building Design, Lund University (2008).

[Wall 2006] Wall, Maria, Energy-efficient terrace houses in Sweden. Simulations and measurements. In *Energy and Buildings* 38 (2006), pp 627-634, Elsevier Science Ltd. (2006).

Planlegging og bygging av passivhus i Lierbyen, Lier Kommune

Bengt Michalsen, Georg Orvedal
Arkitekt Bengt G. Michalsen AS
Aktiv Energi AS
Tlf 37164080, 815 33223,
bgm@aktivenergi.no

Prosjektnavn:

”Huset på haugen”

Sammendrag

Bygging av passivhus for videresalg med hovedmateriale av massivtre hvor kunnskapsformidling og evaluering/måling er hovedtema, med robuste løsninger på en praktisk og økonomisk forsvarlig måte med et oppvarmingssystem som er dimensjonert både økonomisk og teknisk i forhold til behov.

Prosjektet er kommet i gang gjennom interesse og entusiasme for energibruk i bygg, slik at presentasjonen av prosjektet vil fra vårt ståsted gjøres i lys av dette og ikke som en forskningsrapport eller teoretisk utredning med tallverdier og formler.

Vi har som målsetting å bidra til en ”hverdagligjøring” av tanker om energibruk og systemer for dette sammen med inneklimatema og vil derfor presentere prosjektet for bransjen i en ”hverdaglig” språkform. Vi tror dette er viktig for å etablere ny teknologi og forståelse for faget for å oppnå målsettingen om at man i fremtidig byggeri tenker og utvikler bygg med lavt energibruk.

De teoretiske verdier og beregninger vil fremlegges når prosjektet er ferdigstilt og evaluering avsluttet.

Deltakere:

Bygging av passivhus i Lier er et samarbeidsprosjekt med følgende deltakere:

- Byggherre: Aktiv Energi AS
- Arkitekt: Arkitekt Bengt G. Michalsen AS
- Husbanken Husbanken Region Sør, avd Drammen v/Rina Ihlen

Studentene ved følgende høyskoler deltar i prosjekteringsteam, med status konsulenter, og skriver sine Bachelor oppgaver på prosjektet.

- Kons. Lys Høyskolen i Buskerud Lysdesign 3 stud
- Kons. El.autom. Høyskolen i Vestfold Elektro Automasjon 4 stud
- Kons. Bygg,energi Høyskolen i Oslo Bygg, energi, økonomi 2 stud

Øvrige:

- Treteknisk Institutt bidrar til å evaluere inneklimatema og varmemagasinerings i massivtre.
- Siv ing. Øivind Berntsen AS bidrar som konsulent på VVS.
- Vi trekker inn konsulenter på øvrige fagområder etter behov.

Ambisjon og målsetting:

Prosjektet startet våren -07 med målsetting om å bygge det første passivhusprosjekt i regionen som et pilotprosjekt for Husbanken. Byggstart er satt til 25.3.08 med ferdigstilling august-sept -08.

Vi ønsker i dette prosjektet å bruke robuste, anerkjente løsninger som lett kan konverteres til tradisjonell boligbygging. Vi vil også bruke massivtre som hovedbyggemateriale og velge tekniske og økonomiske løsninger for å oppnå passivhus-standard etter definisjon for passivhus fra tyskland (T.H.Dokka-06)

En viktig del av vårt prosjekt, foruten dokumentasjon av prosjektering og gjennomføring er også *evaluering og måling* av prosjektet i etterkant.

Vi vil her instrumentere for å måle energiforbruk til oppvarming, tappevann, lys og apparater. Vi vil også prøve en metode for *gjennvinning av varme fra gråvann* og måle effekt av dette tiltak.

Vi vil bruke nye *LED-lys i 220V* anlegg og vil også måle og evaluere dette tiltak.

I tillegg til dette vil gjøre et forsøk på å *evaluere og måle "bekomfort" og varmemagasiner i massivtre*.

Vi har her fått Jarle Årstad ved Treteknisk Institutt til å bidra med kompetanse og gjennomføring av prosjektet.

Kunnskapsformidling

Passivhus og lavenergihus i Norge er et tilnærmet ukjent begrep i markedet og i byggebransjen.

Kunnskapsformidling er derfor et viktig element i gjennomføringen av vårt prosjekt.

Av denne grunn inviterte vi studenter fra tre Høyskoler til å delta på prosjektet hvor samtlige (9 stk) vil skrive sine bachelor oppgaver på prosjektet.

Vi arrangerer også "Fagforum" i Husbankens lokaler i Drammen hvor alle faggrupper inviteres til å delta, det nevnes byggmestere, meglere, ingeniører, arkitekter etc..

I tillegg til dette er vi invitert i mange ulike settinger til å orientere og holde foredrag om tema. Media har ved flere anledninger gjort oppslag og artikler om prosjektet.

Byggets tekniske utførelse

Bygget skal bygges i massivtre med utenpåliggende isolasjon uten bindingsverk og kuldebroer.

Takkonstruksjon som "flatt-taksløsning".

Det brukes vinduer og dører med passivstandard. Leverandør er pr.dd ikke valgt men vi arbeider med aktuelle alternativer.

Det installeres balansert vent anlegg med 85% virkningsgrad, en del automatikk som styringssystemer og et konvensjonelt sanitæranlegg med gjennvinning av varme fra gråvann.

All prøving, måling og evaluering skal gjøres ved å instrumentere bygget med el-målere, energimålere og temperaturfølere etc, hvor alle data registreres som pulsmåling og kan lagres på database hos instrumentleverandør for videre bearbeiding og evaluering.

Alle valgte løsninger skal kunne defineres som robuste og driftsikre mht å konvertere dette til bruk i konvensjonelt byggeri i markedet for øvrig.

Energiltak

Ekstra isolert bygningskropp, minimere luftlekkasjer og kuldebroer, passivhusvinduer, vinduer mot syd og vest, høyeffektiv varmegjenvinner i ventilasjonsanlegg, LED pærer som belysning, solfangere, varmelagring i massivtrekonstruksjon, varmegjennvinning av gråvann, kulvertløsning for inntaksluft til ventilasjon, fornuftig styringssystem og et informasjonssystem som visuelt viser forbruk til de ulike forbrukskilder(lys, varmtvann, mv).

Problemstilling

Prosjektering:

1. Prosjektere og detaljere massivtre bygg med passivstandard hvor det brukes et nytt produkt som er utenpåliggende Rockwool isolasjon uten kuldebro.
2. Finne praktiske og robuste tekniske løsninger for gjennomføring. Detaljer og løsninger er ikke tidligere dokumentert i Byggforsk Byggdetaljer eller lignende.
3. Prosjektering av elektro, ventilasjon og sanitær krever også utførlig detaljering på massivtrebygg med høye energikrav.
4. Oppnå passivstandard på vårt konsept (tysk standard)
5. Velge og prosjektere et fornuftig oppvarmingssystem for romoppvarming (backup) og tappevann som kan forsvares driftsmessig, teknisk og økonomisk.

Bygging:

1. Bygge fremdriftmessig fornuftig og praktisk for å sikre "rent bygg" og "tørt bygg" hvor bygget oppnår tetthetskrav i hht passivstandard på N50=0.6

2. Detaljer må utføres på en praktisk gjennomførbar måte som ikke krever spesielløsninger ut over vanlig godt håndverk.
3. Formidle kunnskap til alle utførende håndverkere for å opparbeide forståelse for alle elementer og terminologi som gjelder bygging av passivhus.

Måle og evaluere:

1. Energibruk til oppvarming, tappevann, belysning og maskiner.
2. Måle og evaluere enkel metode for gjenvinning av gråvann.
3. Måle og evaluere bruk av LED lys på 220V anlegg.

Metode

Prosjektering:

1. Bruke anerkjent kunnskap om materialeegenskaper, tetting og erfaringsmateriale fra nærliggende konstruksjonsdetaljer.
2. Byggforsk Kunnskapsystemer og produktblad fra leverandører samt erfaring fra praktisk byggeri gjennom mange år.
3. Engasjere konsulenter med kompetanse og erfaring fra bygg med energifokus og massivtrebygg. Massivtreprodusent bidrar med kunnskap om produksjon og gjennomføring.
4. Bruke simuleringsprogram som Simien, Vip+ el. tilsvarende for energisimulering, samt produktspesifikasjoner som beregningsgrunnlag sammen med Norsk Standard 3031:2007
5. Bruke kjent erfaringsmateriale fra problemstillingen, erfaring fra egne lavenergiboliger ferdigstilt høsten -07, "Oppvarmingsystemer for Lavenergiboliger, Stene 2006. Produktleverandører og tekniske vurdering gjennomført sammen med VVS konsulent.

Bygging:

1. Før bygging legges gjennomprosjektert materiale til grunn for gjennomføring. Ansvarlig for utførende har deltatt i prosjektmøter.
2. Det avholdes kurs for ALLE deltakende håndverkere for alle fagområder for opplæring og forståelse av passivhuskonseptet og forståelsen av viktigheten av detaljer. I tillegg arrangeres fagforum i tre faser (prosjektering, utførelse, evaluering) for formidling til bransjen og markedet.
3. Det velges utprøvde og robuste løsninger og produkter

Måle og evaluere:

1. Det installeres nødvendig måleutstyr i boligen, dette knyttes om mot en database hos utstyrsleverandør.
2. Vi har prosjektert et enkelt og rimelig system for gjenvinning av varme fra gråvann fra dusj og servant og vil måle effekten av dette med nødvendig installert måleutstyr.
3. El.anlegg prosjekteres for konvensjonelt 220V anlegg. Utviklingen av LED lys er nå kommet svært langt og aktuelle produkter er klar for markedet i USA. Vi ønsker å montere LED pærer og evaluere bruk av dette med egen kursfordeling for lys.

Teknikk og detaljløsninger

Tomt

Tomten er beliggende i Lierbyen med adresse Saeveien 34b
Området omkring er flatt med morenegrunn. Tomten består av en "haug" beliggende i tomtens nord-østre halvpart. Dette gjør at vi har plassert huset inn i dette hjørnet og derved delvis tilbakefylte fasader i 2 etasjer på to fasader. Vi får dermed helt eksponerte fasader mot syd og vest, hvilket er optimalt gunstig mht sol.
Prosjektet har fått arbeidsnavnet "Huset på Haugen" med bakgrunn som nevnt over.

Boligtype

Huset og arkitektur ønsker å vise og uttrykke et hus av tiden med innovative integrerte løsninger som også "synes" utvendig.
Det er et bygg med utleieenhet i 1.etg og hovedbolig i 2. og 3.etg.
1.og 2. etg er universelt utformet slik at huset kan passe folk og personer i alle livsfaser.

Ventilasjon

Det etableres og installeres balansert ventilasjon med høy virkningsgrad (85%) på varmegjenvinner og lav SFP faktor. Det er tilstrebet korte føringsveier og system for renhold av kanaler.

Vi vurderer bruk av kulvert til inntaksluft for å få noe varmetilførsel fra grunnvarme vinterstid (3-5 °C) eller til nedkjøling av inntaksluft sommerstid.

Det er her også en ide å plassere inntaksventil i glassbygg/vinterhage eller en ”sort boks” som blir forvarmet ved sol vinterstid og med ”bypass” sommertid, også for å unngå kondens i kanalføring etc...

Elektroinstallasjon

Det prosjekteres og installeres konvensjonelt 220V el.anlegg. Som følge av valg av massivtre så må el.anlegg prosjekteres og detaljeres ut over normalt nivå i forkant for å slisse og forbore alle el.bokser og føringsveier i når massivtreelementer produseres.

Elektroinstallatør har dialog gjennom prosjekteringsfase og gjennomføringsfase med lysdesignere og automasjon-konsulenter for å få et optimalt gjennomført og rasjonelt anlegg med nødvendige styringssystemer.

Styringssystemer ønskes lagt på et rasjonelt nivå for å ivareta intensjonen med anlegget nemlig å redusere energibruk på en forsvarlig måte.

Mer preg av ”tekniske finesser” som ”kjekt å ha” legges som opsjoner på salg.

Varmeanlegg

Passivhus har i utgangspunktet lite varmebehov til oppvarming. Det legges til grunn max tilført effekt på 10w/m² og max simulert varmebehov på 15kWh/m² år.

Vi ønsker bruk av solfangere til alt vesentlig tappevannsoppvarming. Solfangere integreres som rekkverk på takterrasser.

Varmeanlegg blir et fellessystem for begge boenheter.

Pipe og tradisjonelt ildsted er i utgangspunktet et oppvarmingssystem man ikke kan forsvare mht varmebehov og problemer med overoppheting når man ”tenner opp i peisen” Dette er likevel et komfort-element vi velger inn mht markedsoppfatning av slike kvaliteter i Norge på en enebolig.

Vi etablerer vannbåren gulvvarme i begge bad og vindfang, samt en radiator i uteleieenhet og 2 radiatører i hovedbolig.

Det velges et fordelingsystem med en kun en fordelingskurs til hver boenhet som fordeler vann med ulik temperatur til gulvvarme og radiator (*Marit Tyholt, ”Varmeforsyning til lavenergiboliger i områder med fjernvarmekonsesjon” Analyser av CO₂ utslipp og forsyningssikkerhet for elektrisitet*).

Radiatorplassering blir i umiddelbar nærhet til gulvvarmeanlegg.

Forøvrig er det lite forskning og resultater av evalueringer om oppvarmingssystemer for boliger med svært lite varmebehov. Vi ønsker spesielt fokus på dette i vår evaluering av prosjektet.

Kapittel 2. Passiv energidesign

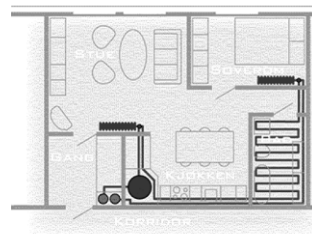

Figur 2-4 Forslag til kostnadseffektivt vannbåren varmedistributionsanlegg for romoppvarming og oppvarming av varmt tappevann, tilpasset lavt energi- og effektbehov, og lite kaldt vann fra vinduer. Illustrasjoner og tittel: Leif Amundli, Norsk VVS Energi- og miljøteknisk forening

Varmegjenvinning fra gråvann (dusj, servant, badekar)

Det finnes lite eller ingen "hylleware" for gjenvinning av varme fra gråvann. Det som finnes er til store felle-løsninger og ikke i småhusskala.(ref. "Valgte tekniske løsninger og simulering av energibruk og inn klima ved Husby Amfi, Dokka og Mahlum -03)

Vi har designet en enkel "gjenvinner" som plassbygges med en massiv betong-blokk med innstøpte 3" PVC avløpsrør (vann fra dusj og servant og badekar) i sløyfer med retursløyfer i kobber hvor kaldt inntaksvann passerer på veg inn i varmtvannsbereder. Dette er en enkel, rimelig og vedlikeholdsgrei konstruksjon som vi ønsker testet ut og evaluert.

Klimarom /vinterhage

Vi har i prosjektet tegnet et klimarom utenfor stue og kjøkken som er ment som en "buffer" mot uteluft vinterstid og kan være temperaturregulerende ved å åpne dør. Rommet skal naturligvis være helt uten tilført energi, foruten det solen tar seg av. Rommet har også en stor miljøeffekt/trivseffekt som rom for planter, tomater og agurker mv...

Det samme rom er vist ved inngang til leilighet i 1.etg. Her ser vi et problem med trafikk ut og inn som hovedinngang pga fuktig luft fra rommet inne som slippes ut pga damptrykk og kondenserer på glassruter i rommet. Det velges her et enkelt glassystem som gir kontinuerlig lufting av rommet og gir rommet tilnærmet utetemperatur og fungerer derved kun som en klimaskjerm mot vind og vær.

Klimarom i begge etasjer skal ha betong i gulv og behandles med relativt mørk overflatebehandling og vil av denne grunn fungere som et varmemagasin.

Energimålsetting

Kriterier	Krav
Brutto energibruk ¹	85 [kWh/(m ² år)]
Kjøpt energi	65 [kWh/(m ² år)]
Total årlig energibruk	65 [kWh/(m ² år)]
Årlig oppvarmingsbehov	15 [kWh/(m ² år)]
Maksimal effekt til oppvarming	10 [W/m ²]
U-verdier og isolasjonstykkelse:	
Yttervegg	0,10 [W/(m ² K)]
Yttertak	0,09 [W/(m ² K)], 500 [mm]
Gulv på grunn	0,09 [W/(m ² K)], 300 [mm]
Vinduer	0,7 [W/(m ² K)]
Ventilasjon (balansert)	
SFP faktor	1,5
Varmegjenvinner virkningsgrad	0,85
Årlig vifteenergi	4 [kWh/m ²]
Lufttetthet	N50 = 0,6 (N = 0,05) oms/h
Varmetilskudd	
Belysning	14 [kWh/(m ² år)]
Apparater	21 [kWh/(m ² år)]
Tappevann	35 [kWh/(m ² år)]

¹Inkludert oppvarmingsbehov kun i fyringssesongen

²Inkludert romoppvarming og tappevannsoppvarming i fyringssesongen som er satt til 4 mnd.

Andre energiltak (som er valgt bort)

Oppvarming gjennom vent.luft.

Som oppvarmingsssystem vil det være enkelt å gjøre dette med varmepumpe og bruke ventilasjonsluften som distributør. Valgt bort av komfortsyn.

Doble glassfasader.

Det er mye brukt doble glassfasader i større bygg for å regulere mot overoppheting og bruke oppvarmet luft som tilskuddsvarme. Dette er mer egnet ved naturlig ventilasjon og krever plass, kostnader og en viss styring for å fungere optimalt. Valgt bort av disse grunner.

Passiv solfanger fra luft

Vi har vurdert et passivt system med forvarming av luftlag på sort fasade som via ventiler innenfra langs gulv åpnes med termostatstyring og med naturlig oppdrift sirkulerer forvarmet luft fra fasade opp gjennom ventil langs inv.himling. Dette system punkterer klimaskjerm og vil kunne forårsake luftlekkasjer.

Solceller

Dette system er anerkjent og hyllevare men faller bort på grunn av for høy investeringskostnad i forhold til effekt.

Resultater

Gjennom prosjektering- og planleggingsfasen har vi hatt ett fagforum med 60deltakere, 6 prosjekteringsmøter med alle høyskolene og øvrige konsulenter mv.

Media har omtalt prosjektet i to omganger. Det vil ytterligere bli arrangert to fagforum, ett i gjennomføringsfasen og ett i evalueringsfasen hvor resultater fremlegges.

Media vil bli invitert til informasjon.

Rockwool som leverandør har utarbeidet en hjemmeside som blir holdt à jour gjennom hele gjennomføringsfasen hvor det legges inn bilder fra alle stadier og hvor alle utførende, prosjekterende og leverandører fører en blogg og legger inn faginfo med linker til aktuelle hjemmesider for å formidle mest mulig erfaring og kunnskap.

I prosjekteringsmøtene er alle kreative innspill diskutert og evaluert. Denne prosessen har krevd noe tid, men har vært svært nyttig for alle deltakere.

Resultater og erfaringer for gjennomføringsfasen og evalueringsfasen vil blir beskrevet i egen sluttrapport .

Konklusjon

Konklusjonen må være at prosjektet så langt har gitt verdifull informasjon og kunnskap. Dette er formidlet til mange i bransjen gjennom fagforum og media, samt gjennom Husbankens hjemmesider som fortløpende blir oppdatert.

En konklusjon er at hvert hus må ha sin egen driftsinnstruks og bruksanvisning, både til drift og forståelse av teknisk anlegg, men også til overflatebehandling av innvendige overflater mv. Erfaringene pr.dd gjør at veien videre og påbegynnelse av nye prosjekter vil være av mye mindre omfang da kunnskap fra dette prosjektet har selektert bort mange "gode ideer" og produkter som viser seg å ikke være aktuelle eller økonomisk forsvarlig av mange grunner blant annet er mange tekniske løsninger mer aktuelle på renoveringsprosjekter og eksisterende bygg som har andre nivåer for luftlekkasje, isolasjonstykkelser og energiforbruk. Dette er også verdifull kunnskap i videre arbeider.

Det er også en konklusjon at vi kan fortsette slik vi allerede nå er gang med når det formidling av kunnskap og erfaring til bransjen.

Tegninger

Plan
1.etg

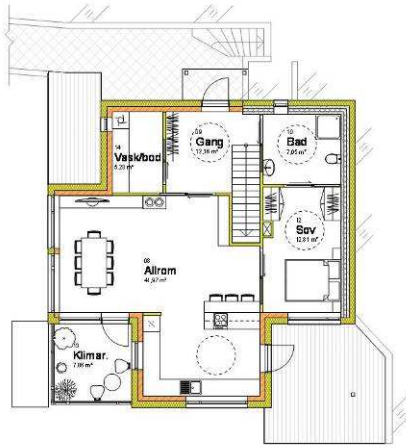

Snitt

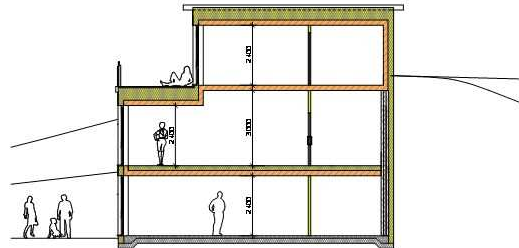

Fasade Syd



Plan u.etg



Fasade vest

Plan loft

Henvisninger

- 1) *Direktive 2002/91/EC of the European Parliament and of the Council of 16 December 2002 on the energy performance of buildings*
- 2) *Dokka Tor Helge, Hermstad K the. Handbok for planlegging av passivhus og lavenergiboliger, 2006*
- 3) *Stene J rn, Oppvarmingssystemer for boliger av lavenergi- og passivhusstandard, 2008*
- 4) *Stene J rn, Oppvarmingssystemer for lavenergiboliger, 2006*
- 5) *Dokka, Tor helge, Wigenstad, Tore, Faktor 4 boliger, 2006*
- 6) *Marit Tyholt, "Varmeforsyning til lavenergiboliger i omr der med fjernvarmekonsesjon" Analyser av CO2 utslipp og forsyningssikkerhet for elektrisitet).*
- 7) *Dokka Tor Helge, Hermstad K the. Handbok for planlegging av passivhus og lavenergiboliger, 2006*
- 8) *Valgte tekniske l sninger og simulering av energibruk og inneklime ved Husby Amfi, Dokka og Mahlum -03*

Det første sertifiserte passivhus i Norge

Dipl.-Ing. Arkitekt Michael Klinski; Sivilarkitekt Lars K. Halleraker; Husbanken Region øst, Postboks 1243 Vika, N-0110 Oslo; michael.klinski@husbanken.no; lars.halleraker@husbanken.no; tlf. +47 22 96 18 26/17 53
Tiltakshaver Harald Ringstad; Haugli, Fossumvegen, N-1920 Sørumsand; hrings@start.no; tlf. + 47 94 84 20 80

1 Innledning

Arbeidet med lavenergiboliger og passivhus i Norge har fått vind i seilene de siste årene. Lavenergibolig er ikke et beskyttet begrep, men den mest utbredte definisjonen går ut på at totalt netto energibehov ikke skal være høyere enn 100 kWh/m² per år. Dette inkluderer all husholdningsstrøm og beregnes i Oslo-klima.

Oppvarmingsbehovet ligger da rundt 30 kWh/2a, uten at det er noe direkte krav til det. Ifølge statistikken bruker en gjennomsnittlig norsk boenhet totalt 214 kWh/2a levert energi. Nettoenergi og primærenergi ligger grovt regnet på samme størrelsesorden fordi de fleste boligene i Norge varmes opp elektrisk og nesten all strøm produseres i vannkraftverk. Med større andel importert elektrisitet eller f.eks. innenlandske gasskraftverk vil dette bildet endre seg.

Siden 1997 forutsetter byggeforskriftene et oppvarmingsbehov på maksimalt ca. 60-90 kWh/m²a. Fra august 2009 vil dette bli innskjerpet og redusert til 40-60 kWh/2a (ut fra et krav om totalt netto energibehov, beregnet i Oslo-klima). Dette er lavere verdier enn f.eks. i Tyskland, som innførte Norges kravnivå fra 1997 så sent som i 2002. Allikevel er energiforbruket relatert til varmt tappevann og spesielt til belysning og teknisk utstyr mye høyere i Norge enn i Sentral-Europa. Hovedårsaken er ikke mørke vintre, men andre beboervaner som følge av svært rimelige strømpriser i årtiene etter 2. verdenskrig. [Hahn 2005]

Enkelte passivhus er allerede ferdigstilt i Tromsø i Nord-Norge og i Skien sørvest for Oslo. Andre er under bygging, men ingen er blitt prosjektert med den tyske "Passivhus-prosjekteringspakke" (PHPP) eller sertifisert av Passivhusinstituttet i Tyskland [Andresen 2007]. Hovedutfordringene ved prosjektering av passivhus i Norge er høye norske verdier for internt varmetilskudd opp mot veldig lave verdier i PHPP, relatert til helt ulike beboervaner, samt store klimatiske forskjeller mellom kyst og innland, som er mye større enn klimaforskjeller mellom sør og nord. Dette blir forhåpentligvis løst i en norsk sertifiseringsordning, som er under utvikling og skal bli ferdig i løpet av 2009 (se sesjon 9, verksted om standardisering og sertifisering).



Figur 1 og 2 Siste takelement heises på plass (t.v.). Arbeidslaget fra Tyskland er fornøyd.
Foto: Harald Ringstad

2 Passivhuset NorONE på Sørumsand

"NorONE" er en tradisjonell enebolig med utleieleilighet i underetasjen og blir det første passivhus i Norge med sertifikat fra Passivhusinstituttet. I tillegg til passivhusstandarden har eieren ambisjoner om å bli selvforsynt på energi gjennom året. Huset skal bli et av svært få med integrerte solcellepanel i tak mot syd. (Det finnes i dag ingen tilskuddsordninger for å stimulere til slike løsninger i Norge.) Huset ligger på Sørumsand, et mindre tettsted nordøst for Oslo. Gjennomsnittelig årstemperatur er 6,2 °C. Dimensjonerende vintertemperatur er -20 °C. Global horisontal solinnstråling er 970 kWh/m²a.

Familien bodde 17 år i Tyskland før de i 2006 flyttet tilbake til Norge. I løpet av årene i Tyskland ble de mer bevisst på eget strømforbruk enn nordmenn flest og etablerte brukervaner som de tok med seg til Norge. I tillegg til dette var eieren Harald Ringstad (en utdannet elektroingeniør) bestemt på å installere LED belysning som gir svært lavt forbruk og nesten ikke overskuddsvarme til omgivelsene. (Dette har senere blitt erstattet av miljøvennlige sparepærer pga. høye kostnader og begrenset utvalg i armaturer for LED belysning.) Etter en fagdag om lavenergi boliger og passivhus i regi av Husbankens Regionkontor øst våren 2006 kontaktet Ringstad Husbanken og søkte om kompetansetilskudd for å realisere et eget passivhus. Han ønsket å samarbeide med en tysk passivhusingeniør og valgte Stephan Blohm fra "passivbau" i Kaltenkirchen.

Husbanken støtter generelt utvalgte pilotprosjekter med kompetansetilskudd for å stimulere til prosjekter som ellers ikke ville blitt realisert. I denne sammenheng er det viktig at prosjekt er et "nybrottsarbeid" med overføringsverdi og relevans for norske konsulenter og boligbransjen generelt. Relatert til NorONE er det gjennomført to halvdagsmøter med ca. 60 engasjerte deltakere. SINTEF Byggforsk fikk tilskudd for å kvalitetssikre de tyske beregningene og de tekniske løsningene. I tillegg til tyske bygningskomponenter er det benyttet skandinaviske bygningsdeler, for eksempel de første norske passivhusvinduer fra NorDan.



Figur 3 og 4 Skisse tegnet av Toril Grønvold (t.v.) og som det ble bygd (balkonger gjenstår).
Foto: Harald Ringstad

En norsk arkitekt, Toril Grønvold, ble opprinnelig engasjert i prosjektet for å sikre at det tyskproduserte huset, designet av "Passivbau", tilpasset seg godt til omgivelsene og den stedlige byggeskikken i Norge. Samarbeidet ble imidlertid avsluttet midt i prosessen, slik at hun ikke fikk deltatt i detaljprosjekteringen. Grunnen var både uforholdsmessig høye kostnader med to parallelle prosjekteringsteam (i Norge og Tyskland) og tiltakshavers eget ønske om kontroll og ansvar for denne prosessen. Harald Ringstad fungerte selv som forbindelsen mellom Passivbau og de lokale håndverkere, og i byggesøknaden til Sørumsand kommune er han selv som oppført som ansvarlig selvbygger, noe man har full anledning til innenfor det norske lovverket. Resultatet – huset vi ser i dag – vil neppe bli trukket fram i arkitekturtidsskrifter, men er snarere et eksempel på at passivhus kan se ut som andre norske hus, uten å signalisere noe ekstravagant.

2.1 Bygningskropp og konstruksjon

NorONE er en stor og kompakt enebolig med totalt bruksareal på ca. 340 m² og en formfaktor A/V = 0,65. I tillegg til eiernes bolig over to etasjer er det en leilighet på 80 m² til utleie i underetasjen. Begge er planlagt etter prinsipper for universell utforming og tilgjengelig med rullestol. Hovedfasaden vender nøyaktig mot sør. Vinduene tilsvarer 14,4 prosent av gulvarealet og er i hovedsak orientert mot sør og vest. Kun 2,4 m² vinduer ligger i fasaden mot nord. Det asymmetriske saltaket gjør det mulig å ha sørvendte vinduer også i loftsetasejen.

Veggene i underetasjen består av LECA-elementer med tilleggsisolasjon. Alle andre vegger er prefabrikkerte treelementer med to lag celluloseisolasjon (241 + 140 mm) mellom hhv. I-stendere og vanlige bærende stendere. Taket består av prefabrikkerte elementer med celluloseisolasjon (406 mm) mellom I-bjelker. Hele konstruksjonen er diffusjonsåpen med OSB-plater som innvendig lufttetting og dampbremse. Skjøter og overganger mot vinduer og andre bygningsdeler er teipet med lufttett klebebånd. Utvendig brukes impregnerte trefiberplater som vindtetting og tilleggsisolering. Platene føres helt inn i til vinduskarmen for å minimere kuldebroer. Av samme grunn er vinduene plassert lenger inn i veggen enn det som er vanlig i Norge.

Alle elementer er produsert av Holzbau Brüggemann i Neunkirchen i Tyskland, som også leverte elementene og monterte dem på byggeplassen i Norge. De første norske passivhusvinduer fra NorDan var allerede tilgjengelig for prosjektet, mens sertifiserte ytterdører måtte leveres fra Tyskland. U-verdier se tabell 1 [Blohm 2007].

Gulv på grunn	0,08 W/m ² K
Yttervegger underetasje	0,13 W/m ² K
Yttervegger ellers	0,10 W/m ² K
Yttertak	0,10 W/m ² K
Vinduer	0,77 W/m ² K
Ytterdører	0,75 W/m ² K

Tabell 1 U-verdier som bygget etter PHPP-beregning. Kuldebroer er i sum negativ.

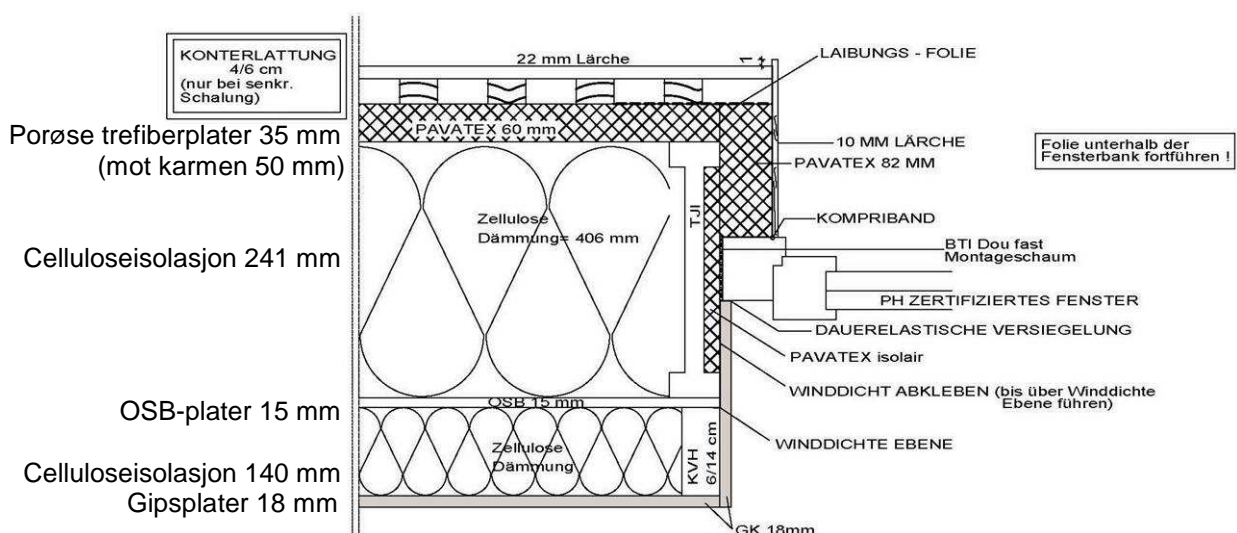

Figur 5 Veggkonstruksjon og vindu. Tykkelser korrigert etter PHPP-beregning.
 Illustrasjon: passivbau^o Stephan Blohm

Etter en diskusjon med Stiftelsen Miljømerking og råd fra Husbanken bestemte tiltakshaveren at celluloseisolasjonen ikke skulle inneholde flammehemmere med borforbindelser. Disse er i Tyskland tillatt til og med i økologiske byggeprosjekter, men for Svanemerket er de bannlyst. Det valgte alternativet, ammoniumfosfat, ble akseptert, slik at passivhuset også kan få det offisielle nordiske miljømerket. Celluloseisolasjon med ammoniumfosfat som brannhemmende tilsetning er imidlertid foreløpig ikke tilgjengelig direkte på det norske markedet.

2.2 Teknisk utstyr

Huset har et balansert ventilasjonsanlegg med 80 prosent varmegjenvinning. Tillafta ledes gjennom en jordvarmeveksler, hvor den forvarmes om vinteren og avkjøles noe om sommeren. Det gjenværende varmebehovet for romoppvarming og varmt forbruksvann dekkes av gråvann-varmeveksler, vakuumsolfanger, luft-til vann-varmepumpe samt – hvis nødvendig på veldig kalde dager – el-kolbe. Det er installert vannbåren gulvvarme og en vedovn. Denne er slett ikke nødvendig, men nesten utenkelig å *ikke* ha i et norsk hjem.

En separat avtrekksvifte over komfyren renser luften via kullfilter. Ved å ikke lede avtrekksluften direkte ut i det fri unngår man tilleggsvarmetap som dette ellers ville medføre. Helt spesielle (ifølge tiltakshaveren) miljøvennlige sparepærer samt hvite- og brunevarer med lavt energibehov reduserer strømforbruket forøvrig til et minimum.

For å kunne måle energibruken i praksis over noen oppvarmingsperioder, ble det installert et overvåkningssystem, som skal bli tilgjengelig på www.norone.info. Det er planlagt å montere et 37 m² stort solcelleanlegg på 5 kWp på taket mot sør, som på solrike dager kan levere overskuddsstrøm til det lokale nettet.

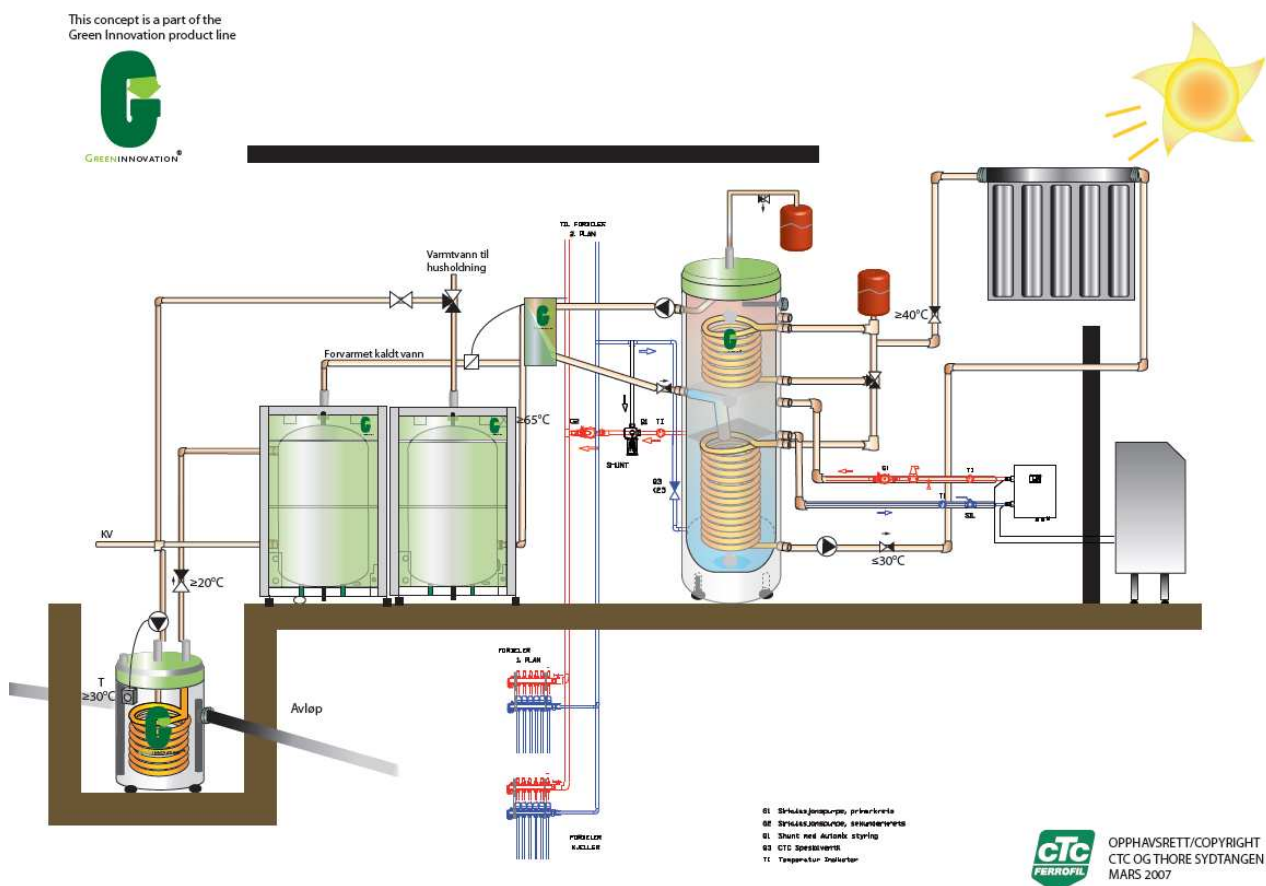

Figur 6 System for oppvarming og varmtvannsberedning. Illustrasjon: cTc

2.3 Resultater fra PHPP-beregninger og tetthetskontroll

Beregnet netto oppvarmingsbehov er 14 kWh/m²a, effektbehov 9,7 W/m²a og totalt primærenergibehov 85 kWh/m²a, basert på tysk primærenergifaktor 2,7 (denne faktoren tar hensyn til stor andel elektrisitetsproduksjon i varmekraftverk; det er ikke bestemt et tilsvarende tall for Norge, hvor nesten alt er vannkraft). Lufttettheten ble kvalitetssikret med en trykktest, som viste et lekkasjetall på 0,39 h⁻¹. Dette ligger langt under passivhuskravet på 0,6 og betyr at NorONE antakelig er det mest lufttette hus som noen gang ble bygd i Norge. Alle planer og kalkulasjoner er nå verifisert av Passivhusinstituttet. Pr. 27. februar 2008 mangler det kun noe produktokumentasjon. Sertifikatet vil foreligge om kort tid.

3 Kritisk diskusjon

Energiforsyningssystemet har mange komponenter. Ifølge forskere fra SINTEF Byggforsk er systemet altfor komplekst og har for mange komponenter for å kunne være kostnadseffektivt. I hovedsak gjelder dette varmepumpa, som installeres i tillegg til både gråvanns-varmeveksler og solfanger. Disse leverer det meste av varmen. Det resterende varmebehovet er veldig lavt, slik at varmepumpa koster mer enn den kan spare inn [Wigenstad 2007]. Resultatet er bra for miljøet, men dårlig økonomisk sett. Uansett, eieren får subsidier for både varmepumpe og vedovn – nettopp de to minst kostnadseffektive komponentene, hvis man ser bort fra solcelleanlegget.

4 Beboernes første erfaringer

Familien, kun tre personer, flyttet inn i sitt nye, store hus 1. desember 2007, omtrent en måned senere enn planlagt. Også noe utstyr var forsinket, slik at målingene ikke kunne begynne samtidig. Leiligheten i underetasjen er foreløpig ikke utleid. Oppvarmingssystemet var ikke i gang de første ti dagene, da det var opp til 14 minusgrader ute. Familien måtte derfor bruke vedovnen, som imidlertid leverte mer enn nok varme også for soverommet – og det til tross for åpent vindu. I ukene etterpå, med gulvvarme i drift, kunne ikke ovnen brukes samtidig fordi det ville blitt altfor varmt. Når de første solstrålene kommer inn i huset, gir de en fin varmeeffekt med en gang, sier familien. Luftkvaliteten er behagelig etter at ventilasjonsanlegget ble satt i drift i slutten av januar. Noen konkrete måleresultater kan forhåpentlig vises på konferansen 2./3. april.

Husbanken har gitt tilsagn om tilskudd på 150 000 norske kroner til solcelleanlegget, tilsvarende omtrent halvparten av investeringskostnadene. Det fins ingen generell tilskuddsordning for strømproduksjon med solceller i Norge. Harald Ringstad har en avtale med den lokale strømleverandøren om levering av overskuddsstrøm, men med de vanlige lave strømprisene vil dette bli dårlig butikk og resultere i underskudd for ham. Om anlegget kan installeres, er derfor avhengig av tilleggssubsidier eller en raus sponsor. Ringstad har snakket og forhandlet med både statens energibyrå Enova og mange norske energileverandører og solcelleprodusenter, men alt uten resultat. Solceller blir i Norge ofte brukt ved hytter uten kobling til strømmettet. Utbyttet over et år er omtrent det samme som i Sentral-Europa. På tross av det – manglende subsidier gjør det vanskelig å bruke solceller i sammenheng med vanlige bygninger. Det er derfor foreløpig ikke klart om Harald Ringstad kan realisere idéen sin og bli selvforsynt med strøm.

4.1 Tiltakshavers personlige kommentarer

NorONE er et generasjonshus over tre etasjer som er bygget i henhold til den tyske PHPP – Passivhusstandarden fra Passivhausinstitut i Darmstadt. Byggingen startet 10. mai og vi flyttet inn 1. desember 2007. Med unntak av enkelte småting er huset ferdigstilt innvendig. Vi gjør oss nå de første brukererfaringer.

NorONE er et forskningshus. Siemens har installert et overvåkningssystem i boligen med målepunkt for alle tekniske komponenter som forbruker eller produserer energi. Disse målingene kan være interessante for mange og er tilgjengelig på internett, se www.norone.info.

Jeg mener at NorONE er et forbildeprosjekt i Norge. Prosjektet vil de neste årene gi oss verdifull informasjon og forskningserfaringer omkring det å bygge passivhus i Norge, og i tillegg brukererfaringer.

NorONE ble støttet med kr 200.000 i kompetansetilskudd fra Husbanken, videre med kr 150.000 til halvparten av kostnadene til solcelleanlegget som totalt vil koste kr 300.000. Enova støttet prosjektet med kr 10.000 til en luft til vann varmepumpe. Dette skjedde bare fordi vi tok en titt på Enovas nettside akkurat de fire dagene støtteprogrammet var tilgjengelig. Dette er for lite forutsigbart.

Frem til i dag var det ikke mulig å få et selskap til å finansiere resten av anlegget. Selv REC som lever 100 prosent av å selge solcellekomponenter, er av den meningen at solenergien ikke er tilstrekkelig og ikke skal brukes i boliger i Norge. ”Vi vil bare støtte prosjekter i land som Tyskland”, sa de for kort tid siden. Når vi vet at Østlandet mottar ca. 100 % mer solenergi på årsbasis enn Nordtyskland, er det skremmende at verdens største produsent for solcelleindustrien, som sitter i Norge, har slike holdninger. De fleste har jo forstått at solenergien er fremtidens energi.

Jeg er av den oppfatning at NorONE, som i de neste årene kommer til å bidra med verdifulle data og forskningserfaringer, fortjener å motta mer støtte f.eks. fra Enova.

5 Konklusjoner for passivhus i Norge

Resultatene fra PHPP-beregningen viser at passivhus kan bli bygd i klimazonen rundt Oslo med samme grunnkonsept som i Sentral-Europa og med akseptable isolasjonsstyrker. Likevel, en frittstående enebolig må være veldig kompakt, ha moderat vindusareal og trenger noe mer isolasjon. Lokaltemperaturene er ikke så lave som mange tror, og soltilskuddet er sammenlignbar med Nord-Tyskland. Totalt er klimaforutsetningene rundt Oslo betydelig bedre enn i Helsinki-regionen, som ligger omtrent på samme nordlige breddegrad.

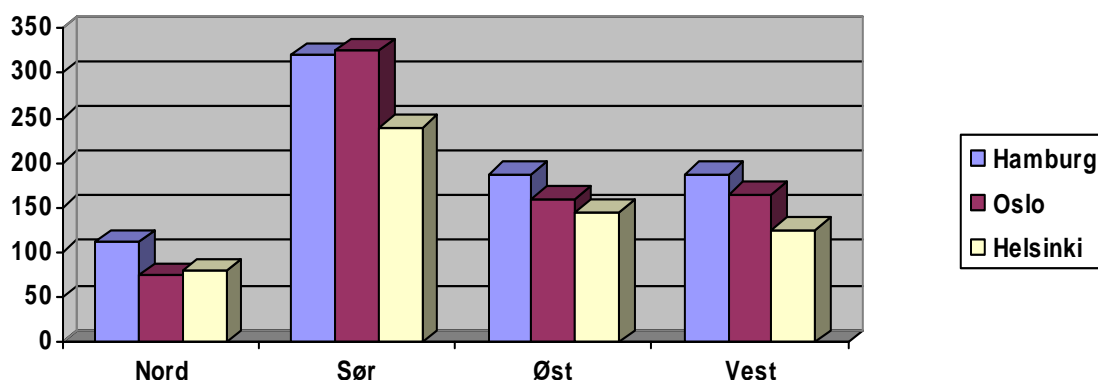

Figur 5 Solstråling (kWh/m²a) på ulike fasader. Referanse: Passivbau°Stephan Blohm

Innlandsområder i Norge kan bli mye kaldere enn Oslo. Mange regioner langs kysten derimot har et varmere klima enn Oslo – sørvestkysten er til og med varmere enn store deler av Tyskland. Flertallet av innbyggerne i Norge bor i regioner hvor det burde være mulig å bygge passivhus. Likevel indikerer disse foreløpige resultatene at det kan bli vanskelig å realisere mindre eneboliger med passivhusstandard. NorONE er et veldig kompakt bygg med stort oppvarmet gulvareal. Samtidig er Harald Ringstad en entusiastisk byggherre med betydelig teknisk kunnskap.

Således vil det bli avgjørende å utvikle passivhuskonsepter relatert til mindre eneboliger for ”vanlige” byggherrer uten spesielle ambisjoner eller kunnskap. Derfor, og tatt i betraktning at to tredeler av alle innbyggere bor i eneboliger, støtter Husbanken nå et nytt prosjekt nord for Oslo, som skal utvikle nettopp et slikt konsept. I dette arbeidet vil erfaringene fra NorONE og entusiasmen fra Ringstad-familien være til stor nytte.

6 Referanser

- [Andresen 2007] Andresen, Inger/Dokka, Tor Helge/ Klinski, Michael/ Hahn, Ulla, Passive house projects in Norway – an overview, Kompendium til 11. Internasjonale passivhuskonferanse, side 147-152 (2007)
- [Blohm 2007] Blohm, Stephan, Passivhaus-Nachweis (PHPP-beregninger på tysk), passivbau^o (2007)
- [Hahn 2005] Hahn, Ulla/Klinski, Michael, Vom Niedrigenergie- zum Passivhaus – Stand der Projekte in Norwegen, Kompendium til 9. Internasjonale passivhuskonferanse, side 441-446 (2005)
- [Wigenstad 2007] Wigenstad, Tore, Notat 004, notat for tiltakshaver, SINTEF Byggforsk (2.7.2007)

7 Nettsteder

www.norone.info
www.passivbau.net
www.husbanken.no

Passive Houses for Arctic Climates

*Petra Vladykova, Ph.D. student,
Department of Civil Engineering, Technical University of Denmark;
pev@byg.dtu.dk*

*Carsten Rode, Associate Professor,
Department of Civil Engineering, Technical University of Denmark;
car@byg.dtu.dk*

*Toke Rammer Nielsen,
Department of Civil Engineering, Technical University of Denmark;
trn@byg.dtu.dk*

*Søren Pedersen,
Passivhus.dk;
sp@passivhus.dk*

KEYWORDS: passive house, arctic climate, simulation analysis

SUMMARY

The article *Passive Houses for Arctic Climates* introduces the new PhD project at Technical University of Denmark, which deals with the German definition of Passive House for the European climate conditions and by means of analysis tries to find an new optimum suitable for Passive Houses in more severe regions where the sources are limited and the best building energy performance is sought. The article illustrates a few examples of the sensible sensitivity analysis made by a thermal building analysis tool – Bsim, where the focus is put on the insulation thickness of wall, roof and floor, and on the window's thermal characteristics. The analysis are made for the Low Energy house build in 2005 in Sisimiut, Greenland, where the weather is extreme and there are long periods with/without sun. Therefore the solar gains are also investigated. Furthermore the simulations are focused on Greenland (Sisimiut) and Denmark (Copenhagen) weather conditions. And the focus is put on how the Passive Houses will work and how their performance could be improved under more severe or even extreme cold climate conditions where the various technologies, energy sources and outdoor climate are very different.

Introduction to the project *Passive Houses for Arctic Climates*

To make a building a passive house as defined by Wolfgang Feist, Passivhaus Institut, its annual heat demand shall not exceed 15 kWh/m², its total primary energy demand shall not exceed 120 kWh/(m²·y), and the air change by 50 Pa pressurization shall not exceed 0.6 air changes per hour. The reference area is net area and well-defined standard conditions apply. Thereby the heat can be supplied just by post-heating after a heat recovery unit the amount of fresh air that is needed to ensure satisfactory indoor air quality. The definition holds for all climates, but can in some climates be realized only by increasing the amount of thermal insulation, by using better windows, and by having a very air tight building envelope while using ventilation systems with highly efficient heat recovery units. Passive houses also take advantage of free gains such as solar heat, heat from occupants and their activities, and possibly from underground heat exchangers.

Supposedly, the Passive House should be realizable in all climates; however the arctic climates pose challenges. The insulation level would be very large, and solar gains are in some areas completely missing or much greater in the part of the year. The heat recovery systems are very often blocked by ice formation; therefore the new implementation/techniques will be needed.

The project *Passive Houses for the Arctic Climates* has the following **research questions**:

- Can the European definition of a Passive House make use in the Arctic countries?
- How will a European Passive House perform in Greenland?
- Could an Arctic Passive House stimulate the development of low-energy building technology in other climates?

The new definition of the Passive House for Arctic climate will be need it and the project should contribute to accomplish this goal where the building will be thermally conditioned to a satisfactory level for indoor and

health environment by minimal provision of energy. Presumably the energy could be obtained from local and renewable (re)sources. The project is focused on current technologies used to achieve such a low energy building in the Europe and in the Arctic. The technologies will be adapted to the extreme climate conditions, where the low energy consumption is a main objective of the study as well as a good indoor climate in the Arctic regions.

The project uses the computational and analytical tools such as BSim, TRNSYS, and PHPP. The computations and analysis will be carried out to investigate the possible extent of reducing energy consumption for conditioning of buildings in Arctic climates, so called **the sensitivity analysis**. It will be sought to determine what it requires to meet the ambition of making building without traditional heating equipment.

Using the computational analysis the current existing low energy and Passive houses in Europe will be virtually moved to the extreme weather regions where the energy-performance analysis of the performance in such climate will be performed. The analysis will answer how the European Passive House will behave under extreme climate and what it would take to turn such a building into the Passive House according to the European Passive House definition.

The project Passive Houses for Arctic Climates is the main topic of recently started Ph.D. project at Technical University of Denmark. Through the Centre for Arctic Technology the project will contribute to the development of optimal energy design for a new dormitory building in Sisimiut (funded equally by the Villum Kann Rasmussen foundation and the A.P. Møller og Hustru Chastine Mc-Kinney Møllers Foundation) that will be build in 2008 in Sisimiut, Greenland, in particular, and for advanced Arctic buildings in general. The project will as well contribute to defining goals for Passive Houses in various climate regions.



FIG 1: Dormitory building in Sisimiut, Greenland

The project will end up with the well-documented summary of technologies to adopt extreme low-energy building technologies in Arctic climates and it will give the scientific input to the new products developments for the extreme climate as well as for the innovation parts for moderate climate. The task is to come up with the definition of a Passive House in the extreme weather regions and such a definition of the well energy performing building could be in the future called **the Arctic Passive House**.

Introduction to the Sensitivity analysis

The article deals with a **computer based parametric study** of the building design of Low Energy House in Sisimiut, Greenland, and checks the results for energy demands. The simulations are focused on modifying of the elements step-by-step:

1. building envelope = external walls, roofs, floor slabs and windows (thermal transmittance of materials)
2. long periods with/without sun and solar radiation (solar gains)

The purpose of the article is to present a few examples of the sensitivity analysis made in BSim where the simulations are focused on the extreme climate in Greenland (extreme weather) and the long periods with/without sun. Later on the completed analysis will lead to answering the following question: What it would take to make an existing Low Energy House in Sisimiut, Greenland, from the low-energy house into the Passive House (German definition) in the Arctic climate?

Low energy building in Sisimiut, Greenland (Norling C.R. et al., 2006) has been built in 2005 by the Technical University of Denmark and Sanaartornermik Ilinniarfik (The Building and Construction School of Sisimiut) with funding from the Villum Kann Rasmussen. Sisimiut is located North of the Arctic Circle (latitude 66.96°, longitude 53.68°; heating season the whole year).

The house is approximately 200 m² and it is a double house with common entrance and technical room. The building envelope has increased insulation thickness and wood profiles with minimum thermal bridge effects (see TABLE 1: for the envelope thermal characteristics). The building contents lots of measuring equipments for measuring the floor heating consumption, solar collector's production and oil burner consumption. Furthermore the house has a newly developed ventilation system with a new prototype of heat recovery unit.

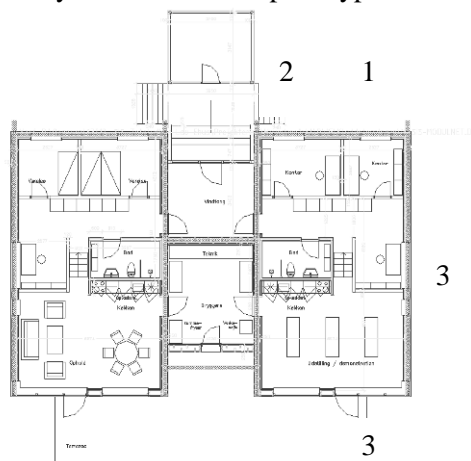

FIG 2: Low Energy House, Sisimiut, Greenland

The used method and Bsim

Method used for the examples of the computational analysis is focusing on the building envelope (wall, roof, and floor insulation thickness, and thermal characteristics of windows). As “LEH designed” is considered the calculated U-value and insulation thickness which were designed and used for building the Low Energy house. As “LEH +10 %” is taken the variation of insulation level by 10 % (e.g. adding extra 10 % of insulation to “LEH designed”). And as LEH -10% is calculated with insulation thickness lowered by 10 % (e.g. taken out 10 % of insulation from “LEH designed”). Also the window thermal characteristic (heat transmission coefficient) has been varied the same way. For input data see TABLE1 and TABLE2. These simulations have been run under the “Sisimiut.dry” file with input date from reference year (Test Reference Year, 2004).

The simulation of LEH has been than run under the “danmark.dry” file to illustrate the energy behaviour of Greenlandic Low Energy house in Denmark (TABLE 5). Furthermore the illustration of the solar gains in LEH in Greenland is modelled in BSim software where the distributions of solar gains all over the year can be found in **Feil! Fant ikke referanseilden..**

Bsim (BSim, 2006) software is a computational design tool for analysis of the indoor climate, energy consumption, and daylight performance of building, developed by the Danish Building Research Institute. The system uses the common building data model with the design tools and typical building materials database (constructions, windows, and doors). The software can represent a multi-zone building with heat gains, solar radiation through windows (with shadings), internal loads, heating, cooling, photovoltaic, ventilation, and infiltration, but also transient moisture model for the whole building.

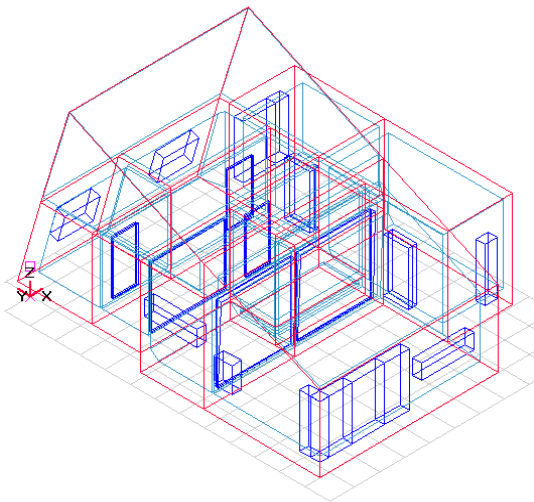

FIG 3: BSim model of Low Energy House in Sisimiut

Results of the examples of the sensitivity analysis

Results regarding the building envelope (wall, roof, floor, window)

TABLE 1: Construction U-values (wall, roof, and floor) and variations

Construction	Thickness [mm]	Calculated U- value [W/m ² K]	Variation of insulation level +10 % * [mm]	Variation of insulation level - 10 % [mm]	Future U-value demand* [W/m ² K]
External wall	300	0.150	330	270	0.200
External floor	350	0.142	385	315	0.150
External roof	350	0.133	385	315	0.150

*Greenlandic Building Code (Bygningsreglement, 2006)

**Designed insulation thickness 300mm plus 30 mm of extra insulation => total insulation thickness for walls is 330 mm for variation -10%.

TABLE 2: Heat transmission coefficient

Type *	U_{glass} [W/m ² K]	U_w [W/m ² K]	Variation of U_w +10 % ** [W/m ² K]	Variation of U_w -10 % [W/m ² K]
1: 1+2	0.70	1.00	0.90	1.10
2: 2+ Vac.	0.70	1.10	1.00	1.20
3: 2+1	0.80	1.10	1.00	1.20

*placement of windows (see FIG 2)

**increasing of the window's thermal characteristic properties by 10 %

NOTE: The following tables "Heat balance in kWh" do not include the heat balance for cooling system, people gains, and lighting energy.

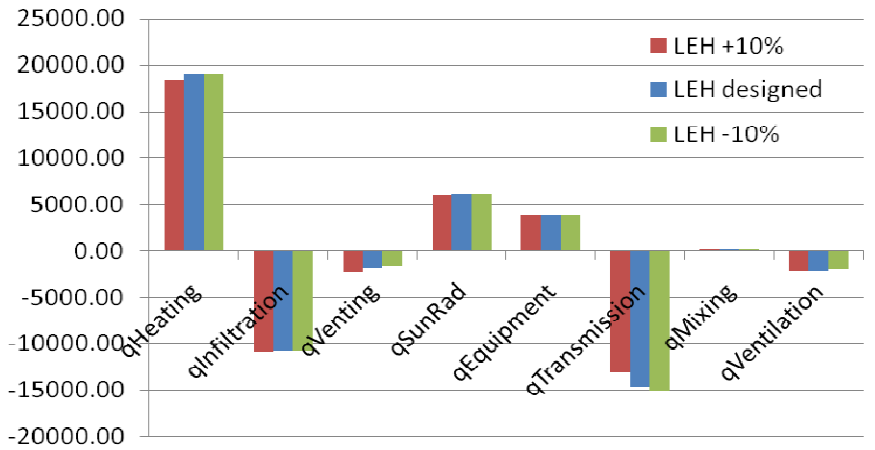

FIG 4: Heat balance in kWh for the Low Energy house placed in Sisimiut (LEH +10 %, LEH designed, LEH -10%)

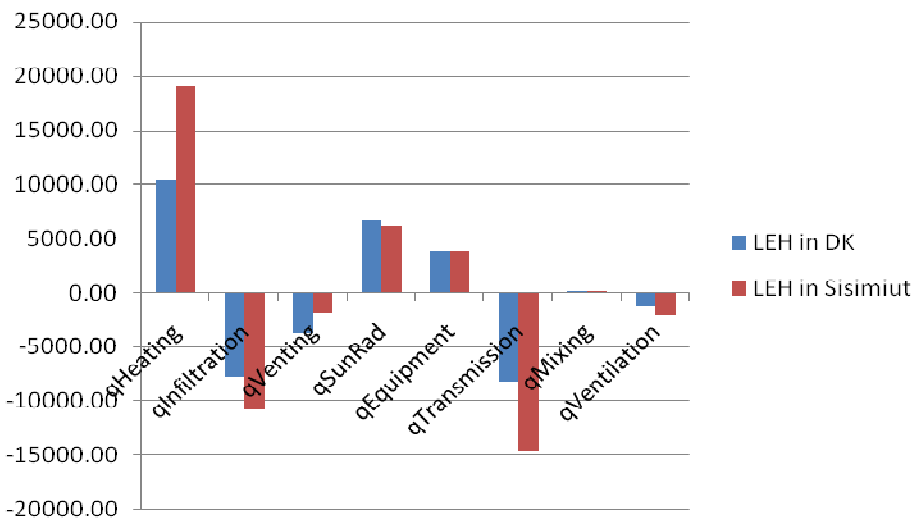

FIG 5: Heat balance in kWh for the Low Energy house placed in Denmark and Sisimiut

Results regarding the solar gains

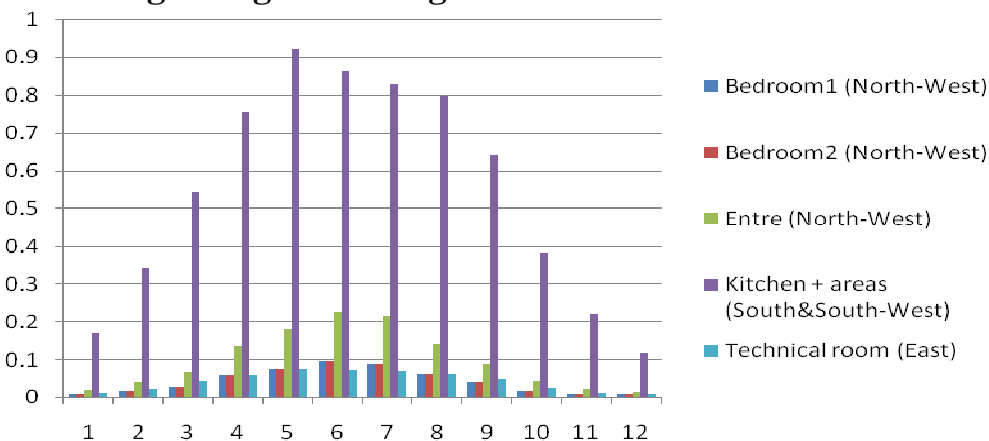

FIG 6: q_{SunRad} for LEH designed (Sisimiut) in kW for the year period for the window area: bedroom1 & 2 = 1.40 m²; entrance = 3.76 m²; kitchen+areas = 12.39 m²; technical room = 1.02 m²

Conclusion

This article has two main purposes: the first is to introduce the new PhD project called “Passive Houses for Arctic climates”, and the latter is to show the examples of so called sensible sensitivity analysis made by a detailed thermal building analysis tool – Bsim. The focus is put on insulation thickness and thermal properties of wall, floor, roof and window.

The examples of sensitivity analysis made for Low Energy House in Sisimiut, Greenland, indicate possible ways of investigating how big the influence is when specific building components are changed, for instance increasing the insulation thickness and thermal performance of windows. The heat balance proves saving energy when increasing the thermal properties by adding extra 10 % of insulations and improving the window performance. But decreasing the thermal performance of building envelope and windows by -10 % has smaller energy savings than the increasing one. The solar gains are significantly large for South side (kitchen+areas) where the window area is 12.39 m² in total, which proves the optimized design of building and the best possible use of solar gains.

Furthermore analyses will investigate the influence of increasing the air-tightness of the building envelope and the performance of ventilation systems with heat recovery units. Later focus should be put also on different habitant's customs (vapour from the cooking, etc.) and on the low humidity in Greenland.

For evaluating more specific and large-scale analysis are needed. The theoretical parametric studies of Low Energy House in Sisimiut have no validation yet and therefore the future comparison with the analysis made in PHPP and TRNSYS will be performed.

References

- BSIM (2006), Integrated software for thermal analysis of buildings and installations. Statens Byggeforskningsinstitut, Danmark. www.bsim.dk
- Bygningsreglement (2006), Ineqarnermut Attaveqarnermullu Pisortaqqarfik, Namminersornerullutik Oqartussat, Grønland, ISBN 87-991296-0-4.
- Feist W. (2004), First Steps: What Can be a Passive House in Your Region with Your Climate?, Passive House Institute, Darmstadt.
- Norling C.R. et al. (2006), A low-energy building under arctic conditions – a case study, Research in Building Physics and Building Engineering – Fazio, Ge, Rao & Desmarais (eds), Taylor & Francis Group London, ISBN 0-415-41675-2.
- Test Reference Year (2004), Sisimiut.try, ASIAQ, Nuuk, Greenland.

Session 5

Planning and architecture

Michael Luring, Rob Marsh Architectural quality of low energy houses	126
Anne Kirkegaard Bejder, Poul Henning Kirkegaard, Henrik Brohus, Anna Marie Fisker MCDM in practice – an architectural point of view	134
Søren Riis Dietz, Mette Maren Maltha "Omgivelsernes indflydelse på design af passivhuse – hvordan optimeres design strategien, så også strukturplaner og bebyggelsesplaner fremtidssikres?"	144
Olav Langenkamp Igangværende passivhusprojekter, Aarhus Arkitekterne.	150
Knut Selberg Passivhus, layout og iboende egenskaber for energioptimering	151

Architectural quality of low energy houses

By Michael Lauring and Rob Marsh, Aalborg University, Denmark.

INTENT AND PUPOSE: This paper expounds a systematic vocabulary concerning architectural quality in houses in general and low energy houses in particular.

The vocabulary consists of nine themes. Inside each theme, examples are given of how to achieve both architectural quality and good environmental performance.

The purpose is to provide a useful tool for communication and argumentation in order to further integrated design of houses with good architecture and good environmental performance.

BACKGROUND: Building physical strategies to create low energy houses affects architecture in many ways: High insulation to reduce heat loss means thicker building envelopes. Attempts to avoid heat conducting materials supplant stone facades in favor of wooden and other light constructions. The size and orientation of windows is crucial both to heat loss and solar heat gain as well as to architecture and indoor climate. The size of rooms and the spatial organization of houses are cornerstones of architecture which can also be related to the ventilation strategies. Attempts to store heat talk in favor of exposing heavy indoor materials.

This is just a few examples of how close low energy building physics and architecture are intertwined. Most building physical strategies have architectural potentials and can be used to ad character, expression and good indoor conditions to a house, if handed properly. If ambitious building physical strategies, as for instance in a passive house, are not combined with good architecture, there are two obvious negative consequences:

1. The inhabitants will have to spend their life in an environment of lesser functional, technical and aesthetical standard.
2. The distribution and prevalence of low energy houses will be obstructed by bad reputation. Dark and clumsy houses don't expand a market.

On the opposite, if low energy is combined with high architectural standards, low energy houses might prevail, also among that great majority of people who looks for a good, local environment for themselves and their family, before they think of caring for the global environment.

Building physical attempts can be measured and argued about in a logical and rational way. Civil engineers are good at this, and the best civil engineers can handle and explain many physical attempts as a whole. Architecture is most often argued about by architects. But even good architects are often not very good at this. Of course architecture is more difficult to be specific about: It cannot be quantified and is not always about logic and rationality. But still, architects should do better and be sharper than just referring to 'architectural quality', 'spatial quality' or the big, mysterious 'wholeness'.

METHOD: The development of the vocabulary is based on literature studies and a cross-disciplinary research project [Marsh & Lauring, 2005] carried out as an iterative process, where environmental knowledge and conditions in Denmark were mapped and organized in the four categories Indoor climate, Energy, Materials and Water; where housing quality where described according to Vitruvius's terms of Strength, Function and Beauty; and where environmental optimization and architectural quality were united in the design of examples of detached housing, terraced housing and multi storey housing with carbon dioxide emissions reduced to 60% below standard. The vocabulary and the given examples have the character of assessments based on knowledge and experience.

THE VITRUVIAN TRIAD: The vocabulary concerning architectural quality lends its main structure from the triad formulated by Marcus Vitruvius Pollio, who was a Roman writer, architect and engineer. Vitruvius is the author of *De architectura* from app. 25 BC, known today as *The Ten Books on Architecture*. It is the only surviving major book on architecture from classical antiquity [Gordon, 2003]. Vitruvius is most famous for stating that architecture should contain the three qualities of firmitas, utilitas and venustas – that is firmness, usefulness and beauty, often referred to as the Vitruvian triad. Firmitas is commonly translated to durability, sometimes to strength. *De architectura* was rediscovered in the fifteenth century and was an enormous source of inspiration for renaissance architecture and in the centuries to come. Up till the nineteenth century the Vitruvian triad stood unshakable as the main definition on the essence of architecture. Since 1990, Vitruvius has

experienced a renaissance amongst environmental architects: He is conscious of the importance of relating architecture to the local climate, and his triad is a practical one. Where postmodern builders might fail to handle constructions with competence and tend not to worry about the finesses of utility while hailing aesthetics as autonomous qualities, to Vitruvius strength, usefulness and beauty stands equal. Neither of them can be expelled. They are cornerstones in the triangle that defines the field of architecture.

But is an antique theory really relevant from a modern environmental perspective? Well, from an environmental point of view, it seems obvious that architecture should be useful. Valuable material and energy resources should be used with care, where it serves a good purpose.

Environmental architecture should also have strength and durability. The longer the house lasts, the lesser resources are used and lesser waste is produced per year. Only should one have in mind that the main environmental impact normally relates to supplying the house with energy for heat and electricity, not from building it [Marsh & Lauring, 2000]. A durable house should therefore be designed for very low energy consumption, or be prepared for energy saving alterations.

Should environmental architecture also hold aesthetic qualities? In the sense that architecture constitutes the local environment of human beings who (in most cases) have a sense of beauty, it should. One could also argue that beautiful buildings are more likely to be taken care of and protected from decline, thus saving material resources.

All in all the Vitruvian triad seems relevant when it comes to environmental responsibility.

But is the definition broad enough? One could argue that Vitruvius' theory only focuses on architecture as a local phenomenon, where good architecture nowadays should have a broader focus, including the reciprocal, physical interaction with the outer environment - the global atmosphere, for instance. Three conditions speak against including such interactions in the definition of architecture itself:

1. If physical interactions are included in a definition of good architecture, one could claim that economic or social interactions with the outer environment should be included too. This would soon leave us with a definition so broad, that the focus is lost.
2. The physical interactions with the outer environment are quantifiable by nature. Making them part of a definition of architectural quality, would only confuse things in general and scientific approaches in particular.
3. The Vitruvian triad is well known and holds a lot of authority. It is better to build upon it, thus letting it support a modern, environmental approach.

It is therefore chosen to develop the Vitruvian triad, still understanding good architecture as a local phenomenon, but with special regards to the physical interactions with the outer environment.

Book I, chapter III, 2nd verse: 'All of these must be built so that account is taken of strength, function and beauty. Account will have been taken of strength when foundations are carried down to the solid ground and materials are wisely and liberally selected; of function when the disposition of rooms of each kind is flawless and presents no hindrance to use and when each element is assigned to its suitable and appropriate exposure; and of beauty, when the *symmetriae* have been calculated correctly so the relative measurements of the members will give the work a pleasing and elegant appearance'. [Gordon, 2003]

This is Vitruvius' own definition of his three key terms. Since Antiquity, symmetry has lost its position as a correct principle of building design, while artificial lighting and ventilation systems have moved in.

In modern terms we speak of the functional, technical and aesthetical qualities of a house:

The functional qualities of the house are named *utilitas* and concern the organization and usefulness in relation to the needs of the occupants.

The technical qualities of the house are named *firmitas* and concern the physical, functional and aesthetic strength and durability of the materials, constructions and technical installations.

The aesthetic or sensuous qualities of the house are named *venustas* and concern the design in details as well as an entirety.

As this definition [Marsh & Lauring 2005] shows, it is difficult to separate sharply the three qualities. One may speak about aesthetic durability: We throw out plastic parts, because they do not age with grace. Is this a durable or an aesthetical phenomenon?

The difficulty of separating the qualities becomes more obvious if we try to sub-divide the three key terms. But that is what we will try to do knowing very well, that systematic structure - at least in human science - seldom fits reality in detail.

THE CONTEXT. The vocabulary is directed first and foremost for designing new buildings. The kind of building we have in mind is a house - in the sense of 'dwelling'. The house can be detached, terraced or a multi storey house. The individual housing unit is thought of as being relatively small and not luxurious - like in social housing, expecting that our aim for environmental responsibility does not allow us to use an abundance of volume or materials for each family.

Small housing units provide us with certain architectural problems: We have to think careful and economically in order to establish good space. And our aesthetics cannot rely on marble or gold. We have to make the best of more humble materials.

AN OVERVIEW. Here is an overview of the vocabulary. As seen below, each of Vitruvius's three key terms are subdivided into three, giving us all in all nine terms:

Utilitas: Spatiality – Accessibility - Utility.

Firmitas: Robustness – Adaptability - Patina.

Venustas: Daylight – Experience - Character.

UTILITAS. The functional qualities of the house are named utilitas and concern the organization and usefulness in relation to the needs of the occupants.

SPATIALITY. How rooms are proportioned, formed and combined.

The basic function of a house is to provide a space for living that is sheltered from the outdoor climate.

Therefore spatiality is the first and basic functional quality. Spatiality is also an aesthetic quality, though. In some buildings, for instance a church, the aesthetical aspects of space may be more important than the strict functional, but in small housing units functionality will prevail.

The space of the house can be defined as the volumes that are limited by walls, floors and lofts. Spatiality is a more complex subject that also includes the perception of space. This perception is dependant on the color and texture of the internal surfaces, and can go beyond the physical limits of the building, as you perceive through windows. Spatiality is often characterized by the opposites open and closed: A dwelling must contain a lot of functions that calls for separation due to noise, damp or wishes for privacy. But the many separations may - especially in small housing units - result in a lot of small rooms, where no room really raises above the claustrophobic. An effort to achieve openness should therefore be part of the architectural strategy.

Spatiality reflects contemporary ideals and values. Historically seen, the modernism of the 1920'es marks an important break, where closed rooms are supplanted by open, floating space, and where big glass facades open up to the surroundings. Mies van der Rohes pavilion for the international exhibition 1929 in Barcelona is a famous example of floating space. [Curtis, 1996]

Make fewer but bigger rooms. For instance by placing kitchen-, dining room- and living room-functions in one big room. Environmentally this will provide better conditions for natural ventilation [Marsh & Lauring, 2003], reduce the use of materials for inner walls, and it may reduce the need for indoor space, if the gangway area is reduced.

Make smaller room smaller to make big rooms bigger. Small rooms can be given a size that allows them exactly to contain for instance bed, wardrobe, table and chair. This can leave space for very big rooms that are not so functionally predestinated. There can be exiting spatial contrasts between small and big rooms, and environmentally the conditions for natural ventilation may be improved.

Make long glances possible. A perception of openness may be furthered be enabling long glances through the dwelling. For instance by placing doors en suite, so one can look through several rooms and perhaps finally through a window, or by designing transparent inner walls. This strategy may also give better daylight conditions thereby reducing the need for artificial lighting.

Secure good height of rooms. This is a key strategy of spatial quality that may further natural ventilation and allow the windows to be placed higher thus throwing daylight deep into the rooms.

ACCESSIBILITY. How the occupants can access the rooms, installations and furniture.

Many people, elderly in particular, have reduced motile, sensory or cognitive functionality. Good accessibility means modest demands for functionality. In dwellings the motile functionality is in focus, and staircases are a typical problem.

Gather related functions. Place the kitchen close to the scullery, the kitchen close to the dinner table, and the bathroom close to the laundering. This will reduce the walking distances. Gathering service functions may reduce the need for pipes and tubes. It may also reduce the heat loss from hot water pipes and secure a quicker supply of water with the needed temperature.

Reduce the number of levels. From the point of accessibility there is only one level in each dwelling.

Make sideways passage possible. Doors may represent a barrier to wheel chair users, so an open plan layout may be preferable, also accommodating natural ventilation. Good accessibility in general will reduce the need for alterations once the house is going to be used by persons with reduced motile functionality, and will thereby reduce the use and waste of building materials.

UTILITY. The capability of the dwelling to accommodate and support the activities of the occupants and their need for storage.

Many activities are dependant on the presence and placement of certain types of furniture. The possibilities of furnishing are therefore an important precondition for utility. It is preferable that a dwelling can be furnished, arranged and used in different ways over time.

To use the furniture in a comfortable way, you need some operating space, for instance in front of beds or closets. Also, furniture should not block gangways. Once the furniture, operating space and gangways have taken their share, ideally some part should be left as free space supporting free movement, activities not related to furniture - and a sense of freedom.

The modernism of the 1920'es was in Scandinavia sometimes nicknamed functionalism. No coincidence, as this architecture meant a break through for a more functional attitude and an aim for a higher utility, with Margarete Schütte-Lihottzkys Frankfurter Küche as the archetypical example [Curtis, 1996]. In Denmark the utility of dwellings reached a high point in the 1950'es, whereas the end of the century has meant a decline due to more focus on style than utility. [Nygaard,1992]. Abundance, also when it comes to the typical amount of space in new housing units, may have weakened the focus on economic plan solutions and utility.

Give the housing unit a general utility. The sketching of furnished plans may secure that the housing unit can be furnished appropriate in several ways, including rooms shifting function. The individual rooms must be sufficiently large and regular to house specific furniture and functions. A general utility will reduce the need for material resources for alterations.

Combine operational space and gangways. This is an important key for economic use of space. As for instance if a small room is provided a breadth so that furniture can be placed at two opposite walls and the (double) operational space at the same time can be used for walking through. Economic plan solutions may reduce the need for housing area and thereby the need for materials, heating and ventilation.

Make furnishing for light demanding activities possible close to windows. Such activities are often related to tables or to chairs for reading. The use of high insulating windows allows sitting or standing close to windows without cold draughts. By utilizing the daylight, the need for artificial lighting is reduced.

Let climatic conditions influence the organization of the housing unit. The most important conditions are the path of the sun, the light and heat related to the sun, and the temperature defining the conditions for thermal drift. Sleeping rooms should be oriented to the north or east, if coolness is wanted in the evening. Living rooms may be oriented to the south and west, to benefit from solar heat. Kitchen and dinner place should be protected from overheating due to west oriented windows. In two-level dwellings, sleeping rooms may be placed on the lower and living rooms on the upper floor, to benefit from the principles of thermal drift.

Spatial organization according to thermal conditions will reduce the need for heating and ventilation.

FIRMITAS. Firmitas characterizes the technical qualities of the house and concern the physical, functional and aesthetic strength and durability of the materials, constructions and technical installations.

ROBUSTNESS. How the construction of the house as a whole is robust in relation to function, action and lifetime.

The house must not sink or break down due to its own weight and the weight of snow, furniture and people. The house must also be able to withstand climatic actions in the form of wind, sunlight, heat, cold, rains or snow.

And the house must withstand the actions from the occupants including the use and diversion of air, water, heat,

electricity and garbage connected to a multitude of installations. Though materials are chosen according to the expected impacts, the individual parts of the house will last for a great variety of years. The robustness of the construction will depend on how worn-out parts can be repaired or replaced without destroying the sound parts of the house. Robustness is therefore not only about lasting long but also about the potentials of renewal. Since the mid-seventies, Danish building techniques have been greatly influenced by attempts to minimize heat loss including thick layers of insulation and layers to ensure air tightness. There has also been a huge escalation in the number and size of technical installations and their share of the total building costs. As these changes have come gradually, the building techniques have typically only been slightly revised. The question is however, whether the environmental conditions – which seem to be sharpened everyday decade – and the technical changes should allow for revolution rather than revision of the strategies for constructing modern housing.

Design buildings that withstand the physical impacts. Such an advice may seem banal, but the postmodern attitude of ‘anything goes’ transferred to building techniques has caused a lot of complicated and hazardous roof and façade details in a field of light and unproven materials. A simple roof shape without roof valleys but with big overhang can prolong the life of both roof and façade. The design of façade details must secure drainage of water. Façades should not necessarily be designed in only one material: Stronger cladding can be used near the ground, at corners and in gateways where the risk of heavy physical impacts are bigger.

Construct for renewal. Building components with short lifetime should not be build into constructions with long lifetime as is seen with roofing underlay for instance.

Reversible joints are important. Screws and bolts, clips and grooves are preferable to nails, glue and strongly adhesive joints. Renewable construction strategies will reduce the use of material resources and strongly improve the possibilities of recycling.

Separate raw house and installations. The technical installation often has a short lifetime, physically and functionally. Instead of building them into long lasting constructions, the pipe work can be visible realizing its aesthetic potentials or it can be placed in installation channels so big, that a human being can inspect, repair or replace the used parts. This will save material resources including metals with short supply horizons. Installation channels will facilitate the installation of energy saving systems and equipment in future years.

ADAPTABILITY. How the house can undergo spatial, constructive or technical adjustments and changes. The adaptability will depend on the character of the bearing system. Traditional bearing facades or the bearing partition walls of industrial high rise limits the spatial possibilities in different ways, while the column-deck system leaves more freedom for spatial changes. The adaptability also depends on to what extend pipes and tubes and other installations get in the way.

Adaptability may add to the architectural character of the house. A famous example is Rietvelds Schroeder Haus from 1924, where the upper floor is one big room that can be split into small rooms by accordion or sliding doors [Curtis 1996].

Separate permanent and temporary parts. Adaptability can be furthered if there are architectural and technical clear distinctions between more permanent parts including the bearing system, and more temporary parts that should be easy to remove when the functional needs of the occupants changes. This can mean a distinction between heavy and light parts using opposites as part of the architectural strategy. The temporary parts must be attached with reversible joints, and eventually the joints can be visible as part of the architectural narrative. Such strategies can reduce the use of materials for modifications. In a material-saving perspective a general utility are preferable to adjustments that are again preferable to reconstruction.

Concentrate pipe work and installations. As mentioned before there are environmental perspectives in separating the installations from the raw house, for instance by incorporating an installation-channel. If kitchen, scullery and bathroom are placed next to the channel, the pipe work is concentrated thereby giving more freedom for spatial changes in the rest of the dwelling. Apart from saving materials such a strategy can mean less heat loss from the utility water system, and the occupants shall not wait for hot or cold water to emerge instead of lukewarm.

Make adjustment to climate possible. Basically the house or housing complex must be formed and oriented towards the wind and sun in order to achieve good indoor climate with the lowest possible need for supplied energy. Subsequently adjustable elements such as shades can be added. Windows and shades might be automat controlled in order to function while no one is at home.

Make environmental improvements possible. Installations, pipes and tubes should be easy to access for environmental alterations. The building envelope might be prepared for installation of solar panels or solar cells, in order to reduce the need for supplied energy without reducing or compromising the architectural expression.

PATINA. How the material surfaces of the house are worn and aged.

Patina may be caused by climatic impacts, dust and air-pollution, microorganisms and insects, or the occupants use and cleaning of the dwelling. Technically seen, patina is a negative process breaking down surfaces. Architecturally, patina may be a positive process adding qualities to a building over time, perhaps being part of a conscious architectural strategy, as for instance using copper cladding expected to turn green.

Choose materials according to the intended architectonic expression. In architectures rational and modernistic oriented periods, smooth and homogenous surfaces are often preferred, securing focus on form and space rather than materials. Such architecture may be dependent on looking new and fresh, wherefore patina is often opposing aesthetic intentions. This can be costly in the long run both economically and environmentally, of which the concrete high rise of the sixties are a good example. Modernistic cladding should be chosen carefully regarding the need to look new.

In architectures more romantic periods, rough unpainted surfaces are more typical as the tactile and material qualities are given more importance. Patina is more accepted here, reducing the need for painting, repairing or renewal, meaning less use of material resources.

Choose materials that do not require a lot of maintenance. Surface treatment is estimated to constitute fifteen percent of the total environmental impacts from building materials, including energy and carbon dioxide emissions [Marsh & Lauring, 2000]. It is therefore important to choose materials with a patina that seldom calls for treatment, or materials that can be treated environmentally friendly with water, lime, linseed oil or silicate.

VENUSTAS. The aesthetic or sensuous qualities of the house are named venustas and concern the design in details as well as an entirety.

DAYLIGHT. How daylight is admitted to the rooms of the house.

Daylight covers direct sun light as well as diffuse light reflected from the sky, from clouds and outdoor environment and from the building itself. Direct sunlight is – compared to diffuse light - characterized by clear direction and sharp shadows. It has a strong intensity and causes much heat. It is dominated by red and yellow colors and is perceived as warm and golden. It is shifting and unstable as its direction and strength depends on the path of the sun and the presence of clouds. Diffuse light is more stable and homogenous casting soft shadows and causing lesser problems with reflection or glare. The colors are cold or neutral.

In architectures modernistic periods, like the nineteen twenties, -sixties and -nineties, much glass was used in the facades giving lots of daylight but also problems controlling the indoor climate. Between the modernistic periods, more romantic periods with lesser use of glass emerged. Environmental strategies has been both passive - reducing the window areas in order to reduce heat loss, and dynamic - adding big glass facades facing south in order to gain solar heat.

Obtain sufficient daylight. In northern climates a strong intake of daylight is normally desirable. The size and placement of the windows are crucial. Light shining through façade windows are normally estimated to descend one meter per two meters in horizontal direction why rooms must not be too deep to be fully lit. Windows in high positions will cast the light deep into the rooms, and bright interior colors will reflect the daylight. If the building envelope is thick, the window reveals may be inclined in order to let the light in.

The more daylight the lesser need for artificial lighting and use of electricity. But environmentally the proportion of windows should also be done in order to minimize heat loss and prevent overheating in the summertime, which calls for smaller windows. Windows should all in all be used economically being placed in close relation to light demanding functions and rooms.

Obtain visual comfort. Visual comfort is dependant on sufficient light but also on avoiding glare and reducing reflection. Glare appears where the contrasts are strong, for instance a sunlit window in a dark wall. Such glare can be reduced with inclined window reveals, light window frames and light colors on the window wall, or by two-sided intake of light.

Working tables should normally be placed in a right angle to the window, but computer screens may have to be turned away from the light to prevent reflections.

Daylight without discomfort prevent that the curtains are drawn and artificial lighting is turned on.

Utilize the varying qualities of the daylight. Day lighting of dwellings is about comfort and atmosphere. Both warm sunlight and cool diffuse light should be admitted to a dwelling. The direct sunlight in particular is a dynamic phenomenon, allowing the occupants to experience the interior change character. The light tells about the passing of the day and the year, shading trees and reflecting snow and water. Thus windows should be oriented towards different views and corners of the world.

EXPERIENCE. How the house facilitates sensuous experiences.

If the human senses are listed according to physical range, the order is normally vision, hearing, sense of smell, of touch and of taste plus the kinesthetic sense related to the movement of the body. Vision often dominates the planning, designing or mentioning of architecture to a degree where the other senses are suppressed or forgotten. But dwellings represent a small architectural scale and frame the most intimate parts of our life, wherefore short range senses must not be forgotten.

While the historicism of the nineteenth century displayed many types of surfaces and tactile qualities, acoustics and kinesthetic challenges, modernism cleaned it up with light whiteness and floating space. In general the twentieth century has represented a move towards emphasizing visual qualities on behalf of the tactile. But rational and romantic approaches still battle.

Activate several senses. Besides visual qualities the dwelling must have tactile and acoustic qualities. The harder and smoother the surfaces are, the more reflection of sound and noise there will be. Perforated materials, perforated bricks for instance, may reduce problems of resonance while increasing the regulation of moisture, which again may reduce the need for ventilation. Many occupants like the smell of wood. Wood is also good for regulation of moisture. Making room for green plants may facilitate stabilization of the indoor climate.

Choose interior materials according to their ability to conduct heat. If the surfaces that the occupants frequently touch feel cold, a higher room temperature may be chosen, resulting in more use of heat. Therefore wooden floors or linoleum may have advantages to stone or tiles. On the other hand, heavy materials may be preferable in rooms that receive much solar heat. Heavy materials storing heat from day till evening may reduce the need for heating.

Accentuate contrasts. This may be a way of sharpening ones senses and increase the amount of experiences. Light-heavy, soft-hard, warm-cool, stretched-loose, convex-concave, calm-dramatic, rough-sophisticated, light-dark, gigantic-human, rhythmic-irregular, natural-ceremonial, bigger-smaller, close-distant are some of contrasts to use in architecture [Rasmussen, 1975]. The use of a two-sided rather than one-sided architectural approach can have environmental potentials: A high-insulated, thick building envelope opposed to transparent parts giving daylight, solar heat and a view. A light building envelope designed to insulate opposed to heavy indoor materials to accumulate heat and stabilize indoor climate. Permanent raw house parts opposed to contemporary parts such as installations. Such opposites will save materials and energy.

CHARACTER. How the house expresses a conscious aesthetic intention.

Character is what differ architecture from mere building. Character is the heart of architecture and constitutes a cultural statement. Opposite 'experience' that will grow with the number of sensuous impacts character might be related to an economic use of effects. Character is an aesthetic phenomenon but may be closely related to the functions, the constructions or the environmental strategies and elements of the building.

Historically, architectural character has often been about the relation to nature. The rationalists and modernists wanted to control nature and stated this in geometric and 'cultural' forms, whereas the romantics tended to idealize and sometimes imitate nature.

Environmental architecture does not necessarily belong in one of these two categories. Architecture might work with nature and climate neither idealizing nor expressing control. Plus, there may be very rational reasons for learning from nature.

Accentuate the interplay between house and climate. The climate changes during day and year, whereas the house must provide a relatively stable indoor climate with a minimum of supplied energy. This can be done with the help of winter gardens, double facades, external shading, solar chimneys or light reflecting mirror pools, all adding to aesthetic expression and environmental performance.

Utilize greenery as part of architecture. Trees and plants, façade greenery, green roofs, balconies with flowers and interior gardens may be an integrated, important part of the architectural expression. Deciduous trees give shade in the summer but access of daylight in the winter, thus supporting low energy strategies. Trees, benches and façade greenery soften heavy winds and reduce heat loss. Plants filter out polluting particles and balance temperature and air moisture both indoor and outdoor.

Build modern. The conditions of society including the environmental conditions have changed so radically, that architecture cannot just rely on experience or the ideas and images of past times including modernism. If the house is to achieve high utility value and good environmental performance, the new conditions must part of programming and analyzing and not only rhetorical. Profound research and programming coupled with the urge and courage to seek new solutions lead to architecture that does not copy, but in the best cases are innovative and path-breaking.

References

- Marsh, Rob & Luring, Michael, 2005: *Bolig – Miljø – Kvalitet*. Statens Byggeforskningsinstitut, Hørsholm.
- Smith, Thomas Gordon, 2003: *Vitruvius on architecture*. Monacelli Press, New York.
- Marsh, Rob, Luring, Michael & Petersen, Ebbe Holleris, 2000: *Arkitektur og miljø. Form, konstruktion, materialer – og miljøpåvirkning*. Arkitektskolens Forlag, Aarhus.
- Curtis, William J. R., 1996: *Modern architecture since 1900*. Phaidon Press Limited, London.
- Marsh, Rob & Luring, Michael (ed.), 2003: *Bolig og naturlig ventilation. Indeklima, energi, driftssikkerhed*. Arkitektskolens Forlag, Århus.
- Nygaard, Erik, 1992: *Senfirsernes boligbyggeri*. Arkitektur DK.
- Rasmussen, Steen Eiler, 1975: *Om at opleve arkitektur*. GEC Gads Forlag, Copenhagen.

MCDM in practice – an architectural point of view

Anne Kirkegaard Bejder¹, Poul Henning Kirkegaard¹, Henrik Brohus¹ and Anna Marie Fisker²

¹ Department of Civil Engineering, Aalborg University, Sohngaardsholmsvej 57, DK-9000 Aalborg, Denmark.

² Department of Architecture & Design, Aalborg University, Denmark.

Abstract

An increased focus on holistic building design has induced the need for methods which can help ensuring that a large number of criteria concerning various aspects of design are integrated in the design process. Multi-Criteria Decision-making methods (MCDM) have been proposed by several as a tool to help structuring the complexity of the design process and hereby ensure that all parameters are properly balanced in the final project. Anyway, while MCDM is a quantitative tool which translates all criteria into a measurable scale, it might be different how useful the method and its results will appear to the different members of the design team, according to their profession and comprehension of design.

In this paper the suitability of MCDM are discussed from an architectural point of view. Through a simplified experiment and dialogue with an architect it is discussed which qualities MCDM might bring to the creative process.

1. Introduction

In recent years there has been an increased focus on environmental issues within the building industry. For one thing this is due to the increased tightening of the demands to buildings energy consumption in order to reduce the CO₂ emissions. As an example of this focus on low-energy buildings one may mention the Passive House concept. With this enlarged focus on low-energy buildings it has become even more important to integrate the large number of parameters and to be aware of the correlation between these. When trying to optimize buildings at several levels at the same time; concerning aesthetics (proportions, materials visual, physical and sensuous qualities etc.) as well as indoor climate, energy consumption, construction, user needs and economic etc. this will result in several different – and often conflicting – design parameters. This has caused an extensive need for methods to help structure the complexity of the design process and hereby ensure that all parameters are included in the final project. Different approaches to an integrated design process have been presented, e.g. “Integrated design process in problem-based learning [Knudstrup 2004], Integrated Design Process - A guideline for sustainable and solar-optimised building design [Löhnert et al. 2004] and “Method for Integrated Design” [Petersen and Svendsen 2007]. Other approaches focus more specifically on the decision-making process.

Among methods which has been developed and presented as tools to facilitate the decision-making process within energy-efficient building design, one may mention ENERGY-10 [Andresen 2000], the Eco-factor [Brohus and Bjørn 2005] and different variations of Multi-Criteria Decision-Making methods (MCDM) [Andresen 2000]. ENERGY-10 is a tool developed by the National Renewable Energy Laboratory in USA which focuses specifically on the energy perspective, providing hour-by-hour energy-performance simulation. The program integrates daylighting, passive solar heating, energy-efficient envelope design etc., and it is specifically designed to evaluate the effectiveness of these different energy-efficient strategies. Furthermore the program provides to rank the different strategies according to their relative effectiveness. The strategies can be ranked by different criteria, such as energy savings, cost savings, or life cycle costs. [Andresen 2000] The Eco-factor is also developed directly to deal with the complexity of low-energy building design. It specifically treats the aspects of indoor climate and environmental effects of energy use, and it provides the designer with a tool, that helps structuring the complexity within this specific relation. [Brohus and Bjørn 2005] Thus these calculation programs can provide the decision-makers with some knowledge that may support a decision and guide the project in the right direction, but only including the quantitative aspects, none of them deals with decision-making from a holistic approach. MCDM, on the other hand, is a much more general method and is known from many different fields, such as policy analysis, social psychology and business management etc., fields characterised by multi-criteria problems. The general purpose of the method is to facilitate the decision-making process by identifying a preferred alternative from a set of alternative solutions that are characterized by

multiple, usually conflicting attributes. [Andresen 2000] Among others [Balcomb and Curtner 2000] recommend MCDM as a tool to facilitate the process of sustainable building design. According to them the use of MCDM facilitates the communication of team priorities, the setting of performance goals and the evaluation of different design proposals. Also [Andresen 2000] sees the potential of MCDM in relation to the design process. According to her a structured approach like MCDM can help clarifying as well as uncover important criteria and help ensuring, that all criteria are considered when making a decision. Furthermore it may facilitate the communication in the design team by providing a common framework that all participants can relate to when evaluating a design proposal.

MCDM may include both quantitative and qualitative criteria but nevertheless it is a quantitative tool, translating all criteria into a measurable scale in order to compare dissimilar criteria and evaluate the performance of each proposal in relation to each single criterion. This scientific and quite positivistic approach to decision-making may be a bit difficult to accept for some architects and non- technicians and it might be different how useful the method and its results will appear to the different members of the design team, according to their profession and comprehension of design.

Thus, it could be interesting to look into how an architect experiences a quantitative method like MCDM as a part of the decision-making process when choosing a design. In order to do so, MCDM is tried out in practice by doing an experiment. The experiment is carried out as a thought experiment based on a design process, which has already been accomplished through a traditional way of making decisions. Therefore the result of the decision-making process will of course be predictable. However, the aim for this experiment is not to try out the method for the purpose of achieving an optimal design. The aim is simply to discuss, through a preliminary study, whether MCDM can help structuring the complex design process and what qualities this might bring to the creative process. The experiment is based on a case study and made in co-operation with the Danish estate consortium Skagen Nordstrand K/S and their design team. The experiment is an exemplification of a design process and focuses only on the development of the siteplan.

Preliminary the complexity of the design process in general is sketched. After that a few examples of MCDM are outlined and the case is described. Thereafter the design processes, using a traditional way of making decisions and using MCDM, respectively, are described and the resulting experiences are presented. Finally, it is discussed on the basis of the experiment, what qualities MCDM may bring to the creative process.

2. The multi-criteria design process

In the following section the principles of the multi-criteria design process are outlined and afterwards a few examples of MCDM methods are presented.

Principles of the design process

When designing a building one faces a complex process. A spontaneous brainstorm quickly reveals a range of different parameters, see figure 01, which will be relevant in most cases, some more relevant than others depending on the type of project.

Context surrounding buildings and functions infrastructure orientation outdoor spaces climate (sun, wind) ...	Technical aspect construction stability strength production ...	Energy consumption building envelope (insulation, infiltration) thermal bridges solar energy (passive, active) ...
Aesthetic expression scale spatial qualities ...	Materials Maintenance Health and safety	Indoor climate thermal comfort indoor airquality acoustics ...
Functionality correlation between rooms flexibility flow ...	Resources economy (overall sum) time ...	Interested parties users client consultants (architect, engineer etc.) legislator the society ...
	Light daylight artificial light	

Figure 01: Examples of different design parameters.

Talking about passive houses, for example, values like good overall economy, good indoor climate and energy consumptions at 70-80 % of a typical house, are usually in focus. This often put the attention on parameters like for example ventilation with high heat recovery, airtight building envelope, thermal bridges, compact building shell, etc. Although these might be the most important parameters seen from the perspective of reducing the use of energy to a minimum, it is crucial that also the more “soft” values like functionality and the aesthetics are included. Through time there have been many examples of energy efficient buildings, where the qualitative values of e.g. spatial, aesthetic and functional character have not been given properly focus. That might be due to the reason, that the quantitative values are much more tangible and thereby easier to put a price on as well as document. But in order to achieve a sustainable building the qualitative aspects are at least just as important. A building which does not fulfil the user’s requirements to functionality and aesthetic appearance, which materials are unpleasant and does not age beautifully, etc. is basically useless no matter how energy efficient it is. Therefore, when designing buildings with very strict demands to the quantitative performance it may be even more important to be aware of including the qualitative aspects.

Well, it is clear that building design deals with a wide range of parameters including both quantitative and qualitative and that it is crucial to include both aspects in order to achieve a sustainable design solution. But the complexity increases even further with the multi-dimensionality of design problems described by Bryan Lawson:

“Design problems are often both multi-dimensional and highly interactive. Very rarely does any part of a designed thing serve only one purpose.” [Lawson 1997]

As an example of this, Lawson describes the window as a multi-dimensional component:

“As well as letting in daylight and sunlight and allowing for natural ventilation, the window is also usually required to provide a view while retaining privacy. As an interruption in the external wall the window poses problems of structural stability, heat loss and noise transmission, and is thus arguably one of the most complex of building elements. ... Because design problems are so multi-dimensional they are also highly interactive. Enlarging our window may well let in more light and give a better view but this will also result in more heat loss and may create greater problems of privacy. It is the very interconnectedness of all these factors which is the essence of design problems, rather than the isolated factors themselves.”[Lawson 1997]

All together this clearly demonstrates how important it is to be aware of all design parameters and their interconnectedness and to bring all of these into the decision-making process. In order to command this multi-criteria complexity of the design process a well structured process is essential.

2.2 Multi-Criteria Decision-Making methods

In the following paragraph two approaches to MCDM are described. Both of them have been developed within the context of the International Energy Agency Task 23, which concerns *Optimization of Solar Energy Use in Large Buildings* [IEA 2008]

In the paper “Multi-Criteria Decision-Making Process for Buildings” [Balcomb and Curtner 2000] describes a design process and associated computer tools recommended by the IEA Task 23. According to them there are two key points in the early design process in which the final sustainability of the building is determined. The first key point is in the pre-design phase when choosing the most energy-efficient strategies and the second is during preliminary design when the design team has to choose between several competing design proposals. [Balcomb and Curtner 2000]

The first method provides the design team with an overview of the most important strategies to implement, thus making it easy for them to see the energy efficient consequences of applying the different strategies at different designs. Using these basic guidelines the designers can focus on other aspects and still ensure the desired level of energy efficiency. In that way the risk of backtracking will be minimized. [Balcomb and Curtner 2000] The aim for the second method is to facilitate the decision-making process during especially the preliminary design phase, where a choice has to be made between two or several design proposals. By evaluating the overall “goodness” of different design proposals based on a weighting scheme that includes all

criteria, the computer program MCDM-23 provides an organized framework for decision-making and a way to document the basis for the decisions. [Balcomb and Curtner 2000]

Phase	Pre-Design	Preliminary Design
Computer program	ENERGY-10	MCDM-23
Focal point	Energy savings	Holistic approach; quantitative and qualitative aspects
Evaluation of Aim	Different energy-efficient strategies Selecting the most important energy-efficient strategies	Total “goodness” of the design proposals Selecting the best design proposal

Diagrammatic outcome

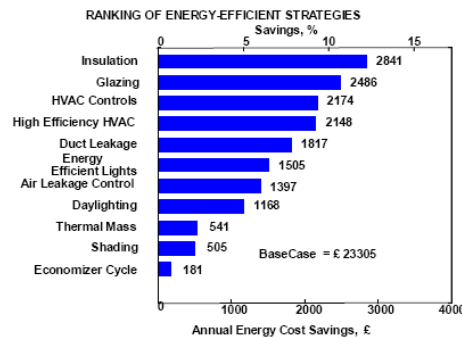

Multi-Criteria Building Performance Chart

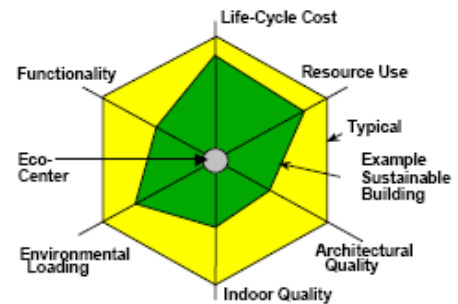

Figure 02: A schematic overview of the two methods.

Through her Ph.D. thesis [Andresen 2000] discusses several different MCDM methods as means to facilitate the process of creating holistic solar design. Regarding the experiment described in this paper two methods seem to be particularly interesting; the simple ordinal ranking method and the simple additive weighting method (SAW). Both of these methods are simple and straight forward to use and besides, studies have indicated, that more complex methods are not necessarily more accurate. [Andresen 2000]

In the simple ordinal ranking method the different criteria are ranked after their relative importance to the project. This weighting of the criteria rely on subjective judgement made by the design team. Afterwards the alternatives are ranked according to their performance on each criterion. Regarding the qualitative criteria the judgements rely on subjective judgement whereas different calculations form the basis of the evaluation concerning the qualitative criteria. Finally, the alternative with the highest number of first places with respect to the criteria with the highest weight is defined to be the preferred solution. This approach is best suited for evaluating qualitative data, especially in one of following situations: 1) When there are only qualitative values to be considered, or 2) The qualitative values are much more important or numerous than the quantitative ones. [Andresen 2000]

The SAW method is the most simple of the so-called aggregate value function approaches. The aggregation model defines how weights and scores for each criterion are synthesized in order to find an overall value for each alternative. This approach is recommended if both qualitative and quantitative criteria are to be included. In that situation all criteria are converted into a common numerical scale and the criteria are weighted. The criteria weights are defined by the design team and work as indicators of the influence of each criterion on the decision. Finally the alternative are evaluated according to each criterion and aggregated into an overall measure of goodness for each alternative using the abovementioned model for SAW.

Through her Ph.D. thesis Andersen repeatedly underlines that the object of MCDM is not to produce a final decision, but should be seen a tool to help the decision makers to be conscious of all design parameters and their mutual nexus. [Andresen 2000]

Regarding building design MCDM is primarily focused on larger buildings with high ambitions concerning a reduction of the environmental impact. However, the aim for this experiment is not to try out the method for the purpose of achieving an optimal design. The purpose is simply to discuss, through a preliminary study, whether MCDM can help structuring the complexity of the design process described in section 2.1. and what qualities this might bring to the creative process. Therefore this experiment will be quite simplified and focus on an isolated smaller part of a design process and only include a smaller range of criteria.

3. The experiment – development of the siteplan

As mentioned above this experiment is an exemplification of a design process and focuses only on the development of the siteplan. As the aim is to discuss MCDM from an architectural point of view only the architect and the owner representative take an active part in the experiment. Also, the experiment will only include a smaller number of criteria. As the main focus is to discuss the method in relation to the qualitative aspects of design, criteria concerning indoor climate, construction, materials, etc. are not included. If looking at the entire design process, these would of course have been present as well as all participants of the design team would have been a part of the process.

The experiment is based on a design process, which has already been accomplished. It is carried out as a thought experiment, where discussions with the architect of the design team help clarify the advantage/disadvantage that MCDM may provide when working in a creative field. While the alternatives are the result of an iterative process, it is most likely impossible to avoid that the architect is biased when evaluating the alternatives using MCDM. However, as mentioned above the aim simply is to get an idea of what one may gain when linking MCDM and the qualitative aspects of a design.

3.1 The Case

The experiment is based on a project made in co-operation with the estate consortium Skagen Nordstrand K/S and their design team. The purpose of this collaboration is to develop and build 1-3 test-houses, which are to be examples of modern low-energy dwellings in wood. The test-houses are a small part of a larger building complex of 45-50 row-houses.

The design team consists of two developer representatives, an architect, a structural engineer and first author of this paper. This constellation has made it possible to have an integrated process from the beginning, where different professions work side by side and offer their professional knowledge when needed.

The experiment presented in this paper is a part of the preliminary design phase, where the design team in agreement has decided, that the siteplan proposed by the district plan does not enhance the qualities of the site. Thus a redesign of the siteplan is needed.

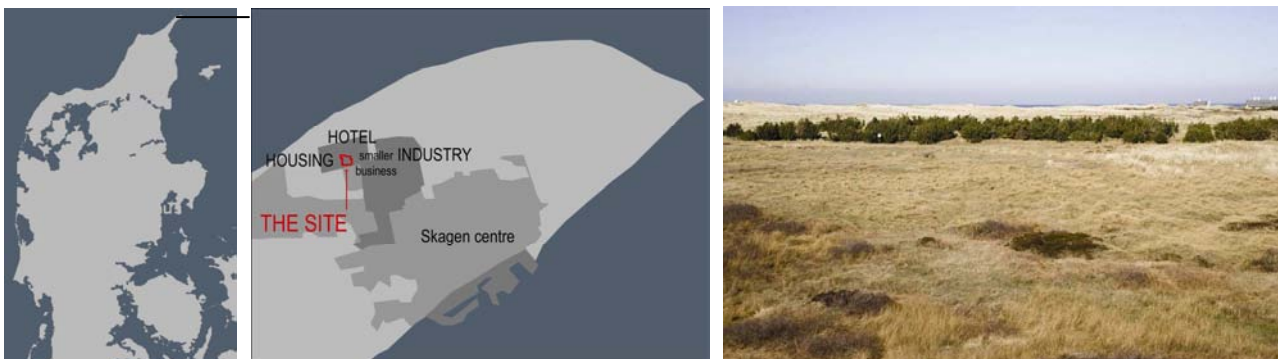

Figure 03: Location of the site in Skagen, Denmark and the view towards the sea.

3.2 Design parameters

Naturally, the process started with an analysis of the site in order to clarify the different parameters such as views, climate conditions (sun, wind etc.), the surrounding buildings and their placement and expression, infrastructure, vegetation and demands from the building code etc.

The site is placed in the fringe of the small town Skagen in the north of Denmark and with a distance to the coastline of only 300 m. The coastline is orientated towards the north-northwest and the view over the sea and the beautiful landscape of dunes is the most important attraction of this site.

The project targets the less deep-pocketed purchaser and therefore the building concept must be economically rational. For that reason it was decided to go for a repetition of just a few housing types and let the architectonic variation be in the siteplan. Due to the primary function as holiday homes the goal concerning energy use of the basis house has been set moderate as low-energy class 2, referring to the Danish building code, at $(50 + 1600/A)$ kWh/m² pr. year, A being the heated floor area. [BR08] In addition to these criteria,

discussions in the design team led to different visions for the siteplan. These were collected in one document named designprogram. The purpose of the designprogram was to unify and describe in words and pictures all design parameters in one document for all parties involved in the project. The designprogram illustrates the overall visions and demands to the project and includes both quantitative and qualitative parameters. Especially relevant to the design of the siteplan, the following visions may be enhanced:

- The landscape must keep its natural character and the dunes be integrated in the design. The design must provide an alternative to the “private garden”; a sunlit private outdoor space protected from the strong winds from west.
- The buildings are to be orientated towards the view to the sea and the nature.
- Hard traffic across the site must be minimized.
- The siteplan must shape one unit, which stands out to the surrounding buildings.
- The houses are to be low-energy class 2.

3.3 Decision-making - the traditional way

The siteplan, which was decided to carry on with, came to light through an iterative process and was developed over several meetings in the design team. At the meetings the architect presented his ideas and drawings which were developed based on his expert knowledge and design parameters from the design program. The designs were then discussed in the design team on the basis of the design parameters from the designprogram, which was continuously updated through the process. During the process smaller studies of daylight conditions were used to support the decisions.

One of the basic issues when choosing this siteplan was quite similar to the complexity of designing a window described by Lawson. In this situation there were especially four criteria, which were conflicting; the optimal orientation of the house according to view, daylight, energy consumption and a private outdoor space with afternoon sun. Placing a larger number of row houses on this ground, the houses are quite compact with openings only in the small facades. Being compact and having a relatively small window area would be great in relation to the heat loss but a potential problem concerning daylight conditions inside the house and make it difficult to gain optimum utilisation of the passive solar heat. Having large windows orientated towards the north was preferred in order to get a nice view to the sea, but seen from the perspective of reducing the use of energy it was a bad solution.

This was an example of the multi-dimensional and interactive design problem described by Lawsons. Because a change in the orientation of the buildings would have an effect on several different parameters, these were more than once objects of discussions where the participants talked at cross-purposes. As an example the architect and the owner representative once had a longer discussion about one of the alternatives and it took a while before the design team realised, that one talked with daylight in mind and the other with the view in mind.

3.4 Decision-making - using MCDM

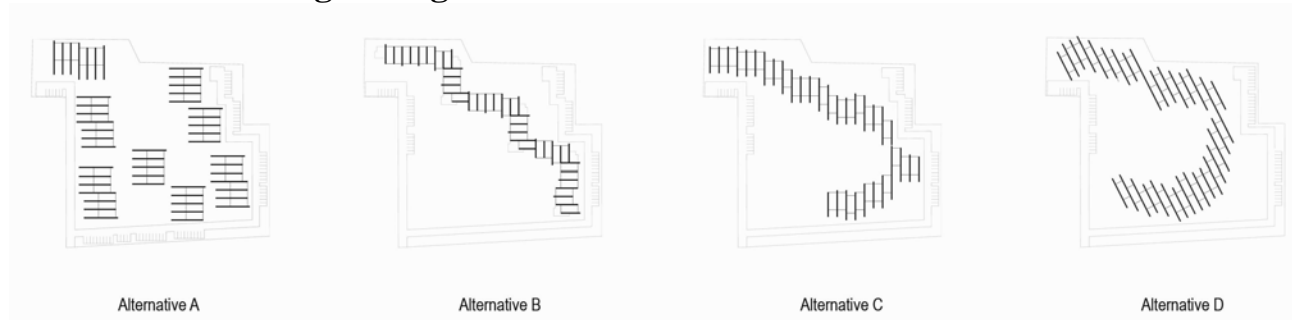

Figure 04: The four alternatives which were chosen as objects for the experiment.

When trying out MCDM the procedure consisted of four steps.

3.4.1. Specification of design criteria.

Until this moment all visions for the project had been mixed together in the design program and some of them were quite loosely expressed. When trying out the MCDM, the visions concerning specifically the site plan had to be further specified in order to be able to evaluate the proposals in relation to each single criterion. This was done in cooperation with the owner representative. The criteria are listed in figure 05.

3.4.2. Weighting of criteria.

The method used in this experiment was the simple ordinal ranking of alternatives. This method was chosen because the criteria are mainly qualitative and because it seemed to be quite simple and easy to use for beginners. Like the specification of criteria the weighting was also based on discussions with the owner representative. The weighting technique used in this experiment was ranking which means that the criteria were listed in order of importance.

This exercise was interesting because the use of the ranking method required a decision about the relative importance of all criteria. Only three criteria were set to be more important than economy, those were dealing with the overall architectural expression, view and daylight. The low weight of the energy consumption also revealed that the focus of the economy was quite short-sighted, mainly on the construction. The reason for this probably is that the project points at the less deep-pocketed purchaser and that the primary function will be holiday homes for which reason the costs for service and maintenance are not in focus.

3.4.3. Ranking the alternatives.

Using the simple ordinal ranking method the four alternatives were ranked according to how well they performed on each criterion. The ranking of the four alternatives was done in cooperation with the architect of the design team while his experiences of the method are the aim for this experiment. Due to the dominating number of qualitative criteria the ranking was primary based on his expert judgement.

Design criteria	Weight	1. place	2. place	3. place	4. place
<i>Qualitative</i>					
- Intuitively most appealing architectural concept	1	D	C	B	A
- Orientated towards the view	3	D	B	C	A
- Creates private outdoor space in lee of the strong wind from SW	5	D	C	A	B
- Creates private outdoor space with afternoon sun	6	B	D	C	A
- Promote separation between private and public outdoor spaces	7	D	C	B	A
- Minimizes the need for hard traffic across the site	9	D	C	B	A
- Has its own life (stand out from the building towards west)	10	D	C	B	A
- Come across as a unit without creating a gated community	11	D	C	B	A
<i>Quantitative</i>					
- Daylight	2	D	C	B	A
- Economy	4	B	A	C	D
- Energy consumption	8	D	C	B	A

Figure 05: Ranking of alternatives according to each criterion.

Most of the criteria were quite straightforward to evaluate the alternatives by but some of them caused a bit more discussion, among others the evaluation of the alternatives according to daylight. This evaluation was actually based on a combination of measurements of the solar radiation and a quantitative judgement of what would be the preferred solution – maximum or a steady amount of solar radiation over the year.

3.4.4. The best performing alternative was identified.

A comparison of how well the four alternatives perform according to the criteria and their respective weight was made. The four alternatives were the result of an iterative process and the criteria as well. Therefore it was also quite natural, that alternative D had a much better score than alternative A, which was the rejected design from the district plan. But using the method revealed that alternative B actually did best when it came to the private outdoor space with afternoon sun and also regarding economy which was the fourth most important criteria. So, even though alternative D did remarkably better than the other alternatives it was clearly that further design was needed and that inspiration could profitably be drawn from some of the other alternatives.

	# 1. places and (weight)	# 2. places and (weight)	# 3. places and (weight)	# 4. places and (weight)	Rank
Alternative A	0	1(4)	1(5)	1(1)+1(2)+1(3)+1(6)+1(7)+1(8)+1(9)+1(10)+1(11)	Last
Alternative B	1(6)+1(4)	1(3)	1(1)+1(2)+1(7)+1(8)+1(9)+1(10)+1(11)	1(5)	Third best
Alternative C	0	1(1)+1(2)+1(5)+1(7)+1(8)+1(9)+1(10)+1(11)	1(3)+1(4)+1(6)	0	Second best
Alternative D	1(1)+1(2)+1(3)+1(5)+1(7)+1(8)+1(9)+1(10)+1(11)	1(6)	0	1(4)	Best

Figure 06: Defining the preferred alternative.

4. Discussion

In this section strengths and weaknesses of using MCDM in the decision-making process related to qualitative design parameters, as opposed to decision-making in the traditional way is pointed out. These are based on the experiment – development of the siteplan – and a succeeding discussion with the architect of the design team.

The first step dealing with the specification of criteria was a good exercise while it led to a deeper understanding of which parameters the owner representative considered to be important. The specification also led to a selection of only the most important criteria and in that way the framework of the project got more clear and defined. Unfortunately it was not possible to do the experiment with the unified design team. If that had been the case, the specification of criteria could most likely have had revealed the values of all the members of the design team and thereby ensured that these were taken into consideration. At the succeeding discussion the architect of the design team expressed, that to him the most important job when using a method like MCDM, lies in the specification of the criteria. These are the foundation of the entire process and if they are not precise enough it will not only be difficult to do the evaluation (step 3) but the result will indeed be misleading. As mentioned earlier, this was also experienced when evaluating the alternatives according to daylight. This criterion was simply not sufficiently precisely described. Another remark to the definition of the criteria was that the two criteria concerning the private outdoor space should have been unified to one criterion. This is due to the fact that the quality of the outdoor space relies on the presence of both sun and lee from the wind.

It was interesting to have the criteria ranked after importance since it revealed an unexposed hierarchy within the parameters that had not been obvious until this moment. A design process can be full of great visions and preferably all are implemented. But most often a design process is full of compromises and an opaque hierarchy may result in dissatisfaction of some of the participants of the design team. An overall goal must be to ensure that all interested parties are satisfied at the end and a necessity to ensure that there must be a mutual openness about one's priorities. The MCDM might facilitate such a transparency. A downside of the used weighting method is that ranking the criteria indicates that none of them are equally important, which rarely will be the situation. Therefore it would also be interesting to see what influence it would have on the result if a different weighting method was used.

While the evaluation was based on a ranking of the alternatives, it was not necessary to transform the qualitative criteria into a measurable scale. In that way the foundation of the evaluation using this specific MCDM method had clear similarities to the traditional way where making a side-by-side comparison. The performance of the alternatives according to the qualitative criteria was in both cases based on the architect's expert judgement. But, when making a decision in the traditional way, the alternatives were evaluated according to the overall set of values, whereas the alternatives were evaluated by one criterion at the time when using MCDM. As mentioned earlier some situations occurred where the participants of the design team talked at cross-purposes during the traditional decision-making process. Situations like this usually result in an ineffective process where resources are spent on unprofitable misunderstandings. When using the MCDM the evaluation process was much more structured while the alternatives were evaluated by one criterion at the time. That might help one to avoid the abovementioned situation with the "talk at cross-purposes". On the other hand, the evaluation of the alternatives by one criterion at the time is also a critical point of the method. Doing this the result tells you nothing about the interaction of the criteria. One thing is to evaluate alternatives according to each criterion. This might have some advantages like ensuring that all criteria are considered and that qualities within even the poorest alternatives are discovered. Another thing is to define a "best solution" based on a numeration. The quantitative evaluation can never include the finer nuances of a design decision, while these are often emotionally defined and rarely possible to describe in words. So, when making the final decision one must

always focus on the entirety of the project. At a point the architect actually expressed that to him the evaluation of alternatives by one criterion at the time could even reduce the appreciation of the entirety of the project.

Another point of criticism of the used method was the impossibility of placing the alternatives on an equal footing. Even if it has no actual influence on the result it might raise doubts about the value of this.

5. Conclusions

When using MCDM in a design process the most important thing to be aware of is, that it must not be mistakenly used to make the final decision. In general, methods can be very useful to help structure the design process but one must never expect them to provide a yes-or-no answer. Evaluating the alternatives by one criterion at the time does not embrace the finer nuances which lie in the interconnectedness of the criteria and which are crucial to the overall experience of the design. The traditional way of making decisions relies on the decision-makers professional competences. The MCDM is not seen as an alternative to the traditional decision-making process but used as a supplement to the human judgement it seem to have potential. Especially to provide the design team with a frame of reference for discussions and used as some sort of checklist during the evaluation of different alternatives it may ensure that all criteria are considered and qualities in even the overall poorest alternatives are uncovered. Through the experiment it was experienced that when using MCDM it is most critical that the criteria are completely precise. If not, the entire process can be misleading.

When designing a passive house the demands one need to fulfil are so strict that there is the risk that all other parameters are unintentionally neglected. In order to reach the high level of low-energy it is of critical importance to have a well structured and integrated process. Using MCDM could be one way to ensure that also the qualitative values have attached the proper importance as long as the final decisions are made by human judgement.

Acknowledgements

The work has been financially supported by Skagen Nordstrand K/S, the Danish Technical Research Council and Aalborg University.

References

- [Andersen 2000] Andresen, Inger, A Multi-Criteria Decision-Making Method for Solar Building Design, PhD-dissertation, the Norwegian University of Science and Technology (2000)
- [Balcomb and Curtner 2000] Balcomb , Dr. J.Douglas and Curtner, Adrienne, Multi-Criteria Decision-Making Process for Buildings, to be presented at the American Institute of Aeronautics and Astronautics Conference Las Vegas, Nevada July 24-28, (2000)
- [Brohus and Bjørn 2005] Brohus, Henrik and Bjørn, Erik, An iterative assessment concept for building design based on the Eco-factor, Journal of civil engineering and management, Vol XII, no. 1, pages 51-56, (2005)
- [Knudstrup 2004] Knudstrup, Mary-Ann, Integrated Design Process in PBL, The Aalborg PBL Model, red. Annette Kolmoes, Flemming K. Fink, and Lone Krogh. Aalborg University Press (2004)
- [Lawson 1997] Lawson, Bryan, How designers think: the design process demystified, Architectural Press, (1997)
- [Löhnert et al. 2004] Löhnert Günter, Dalkowski Andreas, Sutter Werner, Integrated Design Process - A guideline for sustainable and solar-optimised building design,

International Energy Agency (IEA) Task 23 Optimization of Solar Energy Use
in Large Buildings, subtask B (2003)

[Petersen and Svendsen 2007] Petersen, Steffen and Svendsen, Svend, Method for integrated design,
BYG.DTU, Denmark (2007)

[BR08] http://www.ebst.dk/br08.dk/BR07_00_ID110/0/54/0, February 25, 2008.

[IEA 2008] <http://www.iea-shc.org/task23/>, February 25, 2008.

”Omgivelsernes indflydelse på design af passivhuse – hvordan optimeres design strategien, så også strukturplaner og bebyggelsesplaner fremtidssikres?”

Søren Riis Dietz, Bjerg Arkitektur, Algade 44, 2.th, 9000 Aalborg
Mette Maren Maltha, Brix & Kamp, Rådg. Ing., Nørregade 27, 9800 Hjørring

Passivstrategien har udviklet sig meget indenfor de seneste ti år, dog er placering på grunden, omgivelsernes skygger samt havens udformning, og disses indvirkning på byggeriet blevet overset og endnu ikke en del af den samlede passiv – strategi!

Tese: Ovenstående primære designparametre har konsekvenser for sekundære parametre med fokus på bygningsdesign. Dette projekt analyserer de primære faktorerers potentiale for en optimering af fremtidige passivhuse og passivhusbebyggelser.



Case:

Passivhus i Vejle, Danmark.

Bebyggelsen består af 10 passivhuse – der placeres inden for 2 fastlagte byggelinier. Lokalplanen er udlagt således at passivhusene ville komme til at skygge for hinanden hvis de placeres på traditionel vis parallelt med byggelinien. Dette faktum, grundlagte ideen til en nærmere undersøgelse af de primære designfaktorer og potentialet for en udvikling af de kendte designstrategier.¹

¹ [Trebersprung 1994] Trebersprung, Martin, ”Neues Bauen mit der Sonne”, afsnit 6.3, side 64.

Metode

Med udgangspunkt i ovenstående projekt der opføres primo 2008, analyseres betydningen af passivhusets orientering på grunden og beskygning.

Bygningsdesignet er optimeret i forhold til en sydorientering.

Variation af primære designparametre analyseres med følgende simulations værktøjer:

Be06, PHPP og Soldia.

Analysen vil vurdere husets energiforbrug på baggrund af sol-optimeringsparametrene beskygning og orientering:

Casen analyseres i forhold til parameteren orientering:

- Optimal primær design strategi – sydorientering
- Minimal primær design strategi – 25 grader fra sydorientering
- øst/vest og nord orientering.

Ligeledes analyseres:

- Skygebilledet - det faktiske skygebillede og beregnet skyggegeometri.
- Horisontskygge - indflydelse fra bevoksning.

Desuden vil vi gennem analyse af casen belyse, hvilken indflydelse, solens højde på himlen i vintermånederne har i Norden i forhold til Mellemeuropa.

Dette afgrænses ved, udelukkende at belyse den sydvendte facade, da det hovedsageligt kun er denne som udsættes for direkte stråling i Norden.

Positionerne på billede 1, anvendes i analysen af det lodrette solindfald på sydvendte facader.

Billede 1



Soldiagram for et udvalgt sydvendt vindue i passivhuset. Diagrammet viser den matematisk bestemte skygge i programmet soldia og den faktisk registrerede på stedet.

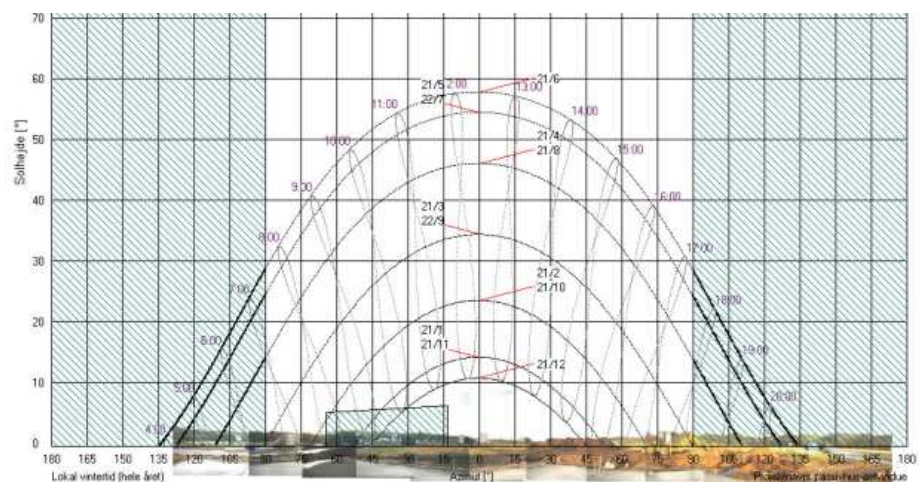

Billede 2.

Det årlige solindfald på en lodret orienteret flade er større mod nord end i Mellemeuropa. 519 kWh direkte solindstråling i Trondheim og 398 kWh i Bregenz, hvilket er 23,3 % mindre end i Trondheim. Beregningen er foretaget med et klimadatasæt for København. Der er således ikke taget højde for klimaets indflydelse på forskel mellem direkte, diffus og reflekteret sollys.

Det fremgår af diagrammet at sydorientering udgør et større potentiale for et energioptimeret design i Norden, det skal dog bemærkes at soltiden varierer kraftigt over året.

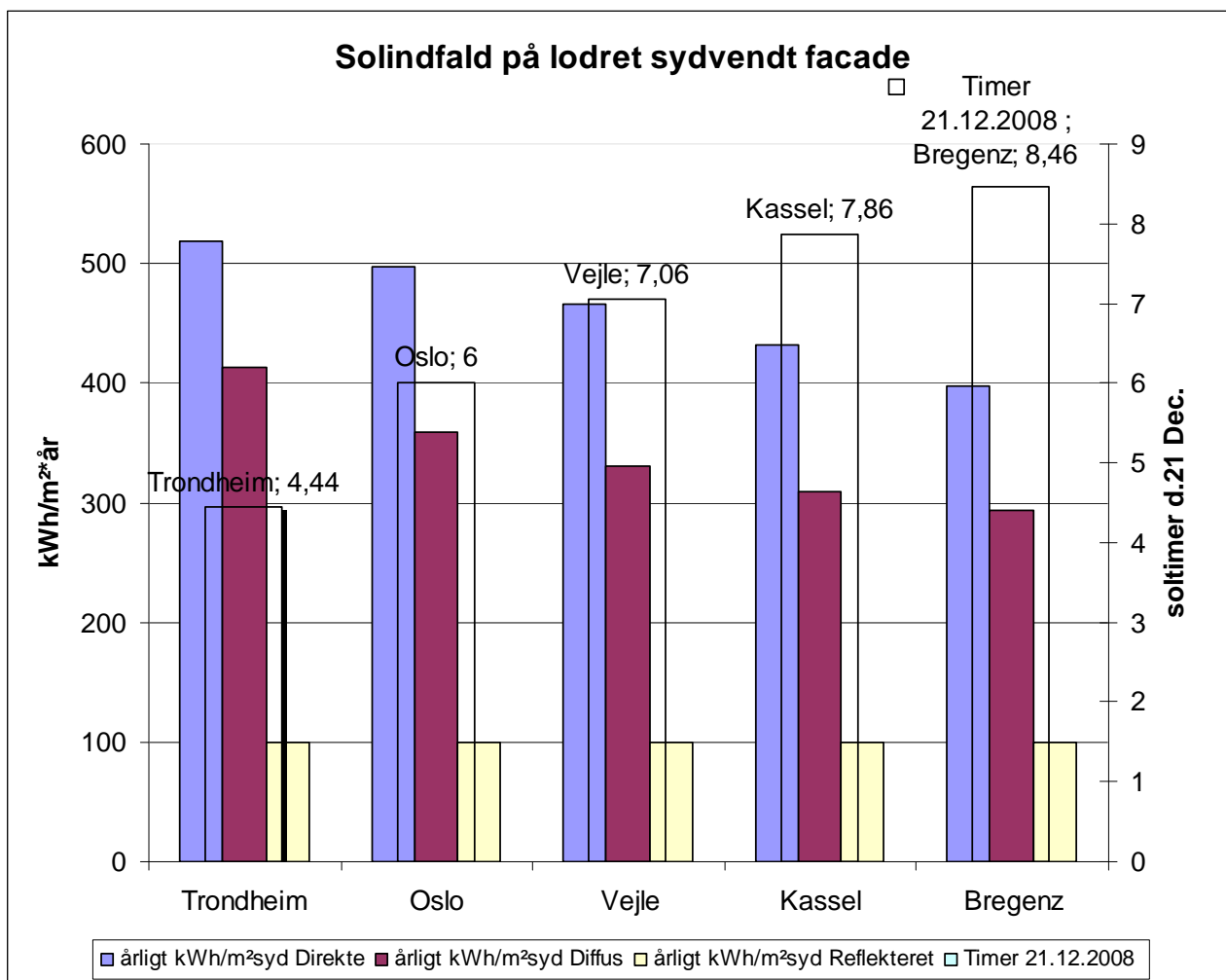

Tabeldiagram 1

Passivhuset er orienteret stik syd og glasarealet er søgt optimeret i forhold til planløsning og ydre sol-skygge forhold. Diagram 2 viser det samlede solindfald på husets lodrette vinduesflader (vinduesmål). Det sydvendte glasareal udgør langt den største andel. Det er bemærkelsesværdigt at den diffuse og reflekterede andel af solindfaldet udgør ca. halvdelen. Beskygning fra den planlagte bebyggelse har kun indflydelse på det direkte solindfald – men den er ikke bemærkelsesværdig.

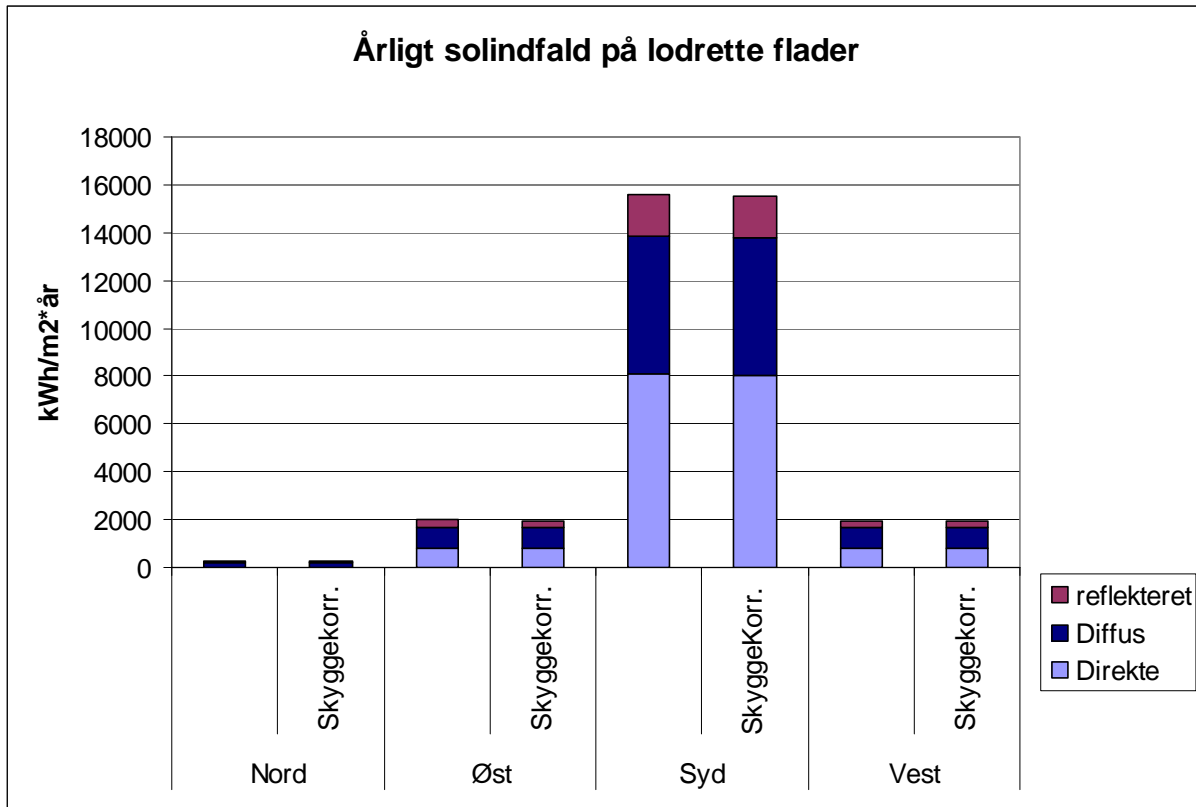

Tabeldiagram 2

Beregninger viser, hvordan et hus med passivhus udformning, taber ganske meget energi til opvarmning, alene ved 25 grader rotation fra sydaksen. Roteres bygningen fra 25 grader mod 90 fra sydaksen vokser behovet for optimering af de primære designparameter dramatisk – se Tabel 3.

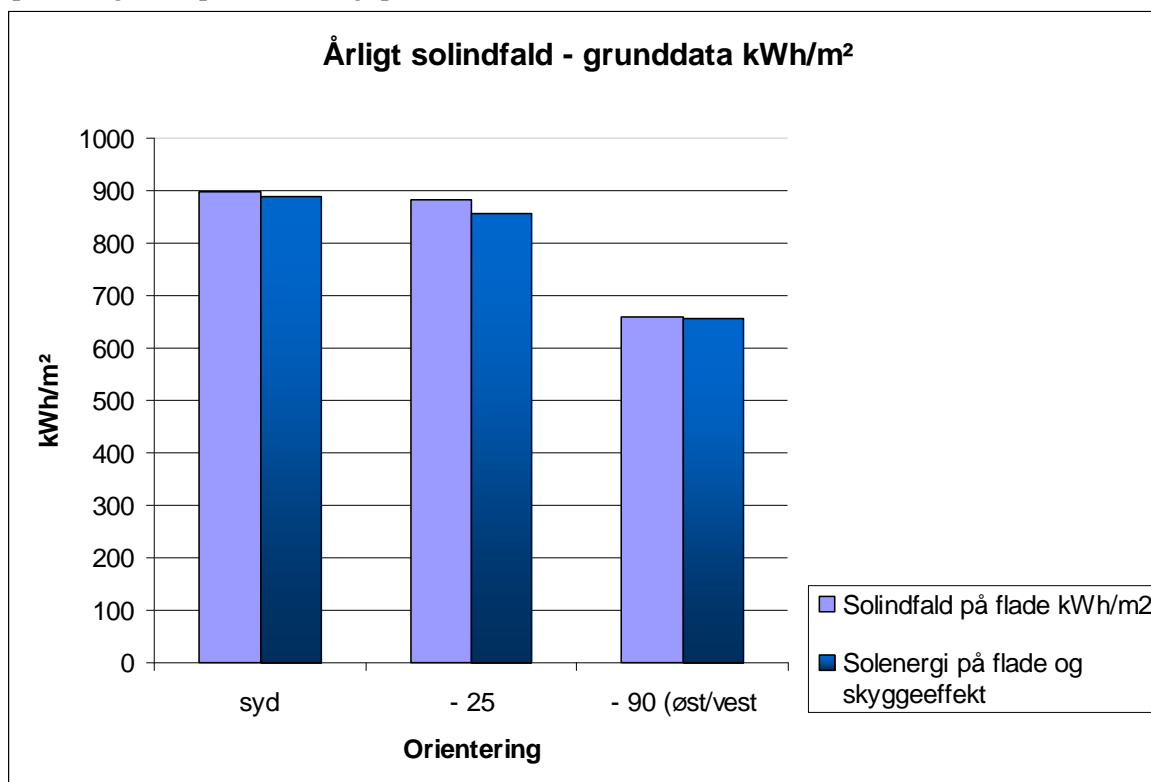

Tabeldiagram 3

Glasarealfaktor A_{syd}/A_{total} og det samlede energibehov til opvarmning for casen er præsenteret i tabeldiagram 4.

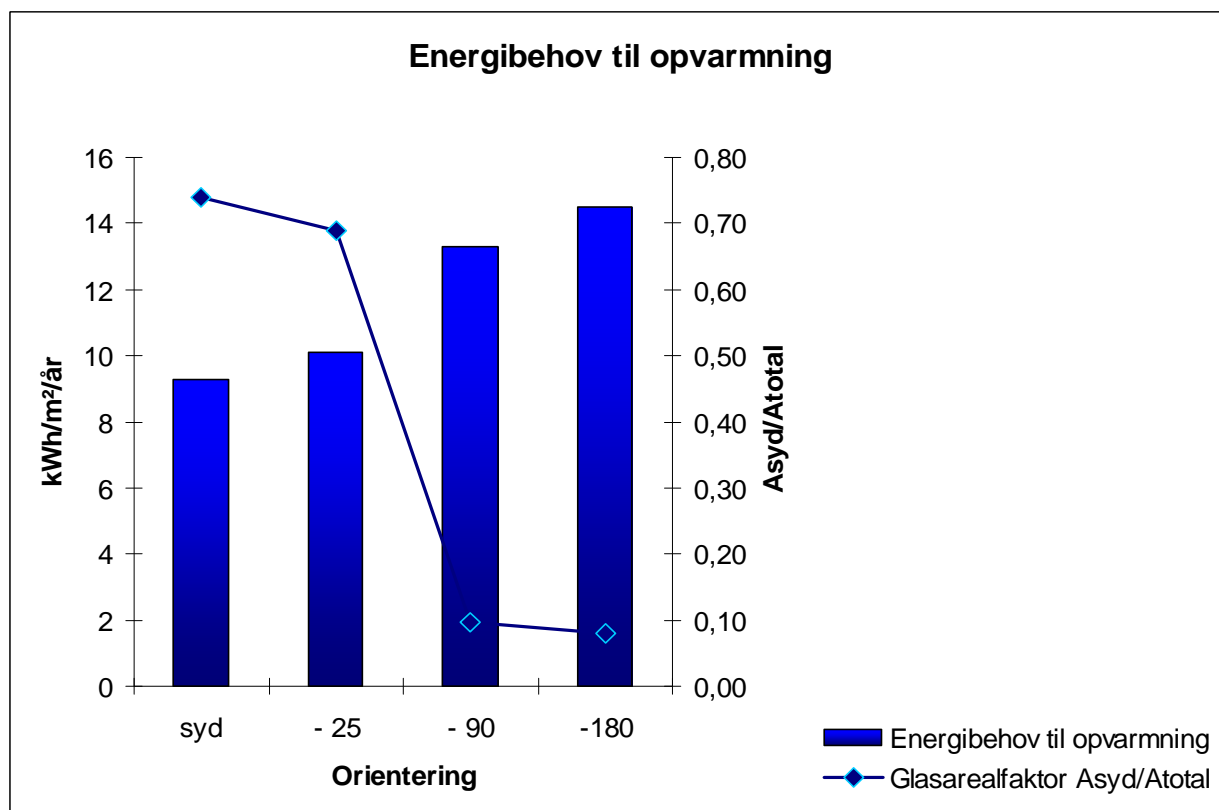

Tabeldiagram 4

Beregninger viser, hvor meget ekstra energi dette passivhus skal anvende til opvarmning af boligen ved forskellige orienteringer i forhold til syd. Ved 90 graders rotation forøges energibehovet med 43% i forhold til den optimale placering mod syd. Dette kan primært begrundes med vindues orienteringen mod syd, som reduceres fra 74% til blot 10%.

Glasfaktorareal tallet blev præsenteret af W. Pokorny som et erfaringstal, til brug i projekteringsfasen ved huse som blev optimeret i forhold til optimalt sol og lys indfald.²

Dette øgede energiforbrug kan omsættes til, tilsvarende nødvendig ekstra isoleringsmængde for at opnå samme energibehov til opvarmning, hvilket er beskrevet i nedenstående tabel 1. Der er primært valgt at efterisolere i tag og terrændæk for ikke at reducere boligarealet unødigt.

Tabel 1

	25°	**	90°	**	180°	**
Ekstra isolering i tag*	75mm	18%	50mm	12%	150mm	37%
Ekstra terrænisolering	0mm	0%	100mm	33%	180mm	60%

* Tagkonstruktion incl. træ konstruktion i elementopbygning.

** Procentvis forøgelse af isolering i konstruktionen.

Konklusion

Husets placering samt omgivelsernes udformning er en vigtig primær faktor i design af fremtidens passivhusbebyggelser. Korrekt orientering og placering, kan give energigevinster på over 40% af det samlede energiforbrug til opvarmning på årsbasis. Alternativt kan isoleringstykkelser øges som vist i tabel 1 eller bebyggelsen – sekundære designparametre kan – kan udformes mere kompakt.

Solindfaldet på den sydvendte flade er bemærkelsesværdig større i Norden end i Mellemeuropa. Det bør medføre større bestræbelser på at optimere struktur – og bebyggelsesplaner således at en sydvendt orientering af huset er mulig.

Perspektivering

Primære designoptimeringsfaktorer kan have store konsekvenser på endeligt design af bygning hvis de ikke udnyttes. De kan føre til meget store isoleringslag – og en orientering mod vest/øst med uforudsete kølingsbehov og energiforbrug som konsekvens.

Dette paper har ikke belyst udbredelse af beplantning, opsætning af hegn, drivhuse eller redskabsskure på parcellerne, hvilket kan give ulemper, samt have fremtidig betydning for naboernes energiforbrug, i form af mangel på direkte lys og varme indfald.

² [Trebersprung 1994] Trebersprung, Martin, "Neues Bauen mit der Sonne", afsnit 6.6, side 67.

Igangværende passivhusprojekter, Aarhus Arkitekterne.

Olav Langenkamp, Arkitekt eth-maa, Aarhus Arkitekterne, Europaplads 16, DK-8000 Aarhus

Aarhus Arkitekterne har gennem de sidste to år specialiseret sig inden for passivhusbyggeri såvel som lavenergiprojekter. Tegnestuens passivhusafdeling arbejder på nuværende tidspunkt med flere passivhusprojekter. Spændevidden rækker fra enfamilies passivhuse til rækkehusbebyggelser i passivhusstandard over til renovering af eksisterende boligblokke efter passivhusstandard.

Foredraget fortæller om tegnestuens aktuelle passivhusprojekter, som bl.a. involverer enfamiliehuse, 66 studenterboliger som passivhus med integreret brint-teknologi – det første CO2 neutrale bygning i Danmark såvel som renovering af en eksisterende boligblok i Århus efter passivhusstandard.

Udover de forskellige projekter belyser foredraget hvordan samarbejdsformer mellem arkitekten, ingeniøren og entreprenøren er i forandring i forhold til at kunne opfylde de skrappe passivhuskrav.

Vedlagt referenceblade med beskrivelse af nogle passivhusprojekter, der bliver præsenteret.

Passivhus, layout og iboende egenskaper for energiøkonomisering

Knut Selberg
Selberg Arkitektkontor As
Leiv Eiriksson Senter
7492 Trondheim

Problembeskrivelse

Det foregår mye forskning på passivhus, både på aktive så vel passive metoder for å oppnå dette. Energiforbruk skal ned, med et ideal om nullutslipp. Samfunnet stiller økende krav til redusert energiforbruk og med det, redusert forurensing. For å oppnå dette så er det flere ”angrepsvinkler” til hva et passivhus er:

- Varmeisolasjon
- Balansert ventilasjon
- Varmepumper
- Alternative energikilder

Felles for disse tilnæringsmetodene er at de ser på teknologien i bygget i seg selv, eller den enkelte leilighet. Påstanden i denne artikkel er at passivhuskonseptet også må omfatte hvordan nye bydeler, tettsteder og boligområder utformes og organiseres. Geometrisk form og layout prinsipp har iboende egenskaper som kan ha like stor effekt på miljøet som energibehov til det enkelte bygg og forurensningsproduksjon. Passivhus begrepet må utvikles til et ”utvidet” miljøbegrep. At et enkelt bygg er et passivhus betyr ikke at alle miljøgevinster er tatt ut, eller at det er miljømessig riktig at huset er der det er. Layout påvirker også parametere som lengde på veg, vann og kloakk pr bolig, transportbehov og avhengighet av denne³. Dette har effekter igjen på byggekost og ikke minst energiforbruket ved å benytte en gitt infrastruktur. Boligen har ikke bare et energiforbruk i seg selv, men også det energibehov etableringen og det daglige transportarbeid som arealplanleggingen genererer. For miljøet spiller det mindre rolle om energi forbrukes til å varme opp en bolig eller om det brukes til transport. I tillegg til dette påvirker organisering av boligfelt ikke bare investering og transportkostnader, men i høyeste grad boligens iboende egenskap for å kunne være et passivhus. Artikkelen diskuterer passivhus ut fra to ståsteder – egenskap knyttet til boligens form og organisering og til slutt egenskaper ut fra de planmessige egenskaper og noen av de føringer dette gir.

Egenskaper til bygningers form

Det er to områder som har vært lite fremme i fokus og det er husets iboende geometri forholdet mellom gulvflate og ytterflate og den effekt dette har på et robust passivt energikonsept. Hus med en gitt konstruksjon har ulike iboende egenskaper (f eks kvadratisk kontra langt og smalt), antall etasjer og ikke minst geometriske prinsipper for planlegging og organisering av boligområder. Dette er enkle matematiske sammenhenger som lett lar seg beregne og dokumentere. I artikkelen er det valgt noen standard dimensjoner som speiler typisk situasjon i markedet som benyttes konsekvent. For å få fram boligens iboende egenskaper så har denne artikkel følgende begreper og antagelser: Boligens energipotensial (BEP) er et uttrykk for iboende egenskap i forhold til varmetap basert på boligens geometri og organisering. I alle regnestykker har en gjort følgende enkle forutsetninger:

- Yttervegger har en BEP på 1 pr m²
- Tak⁴ har en BEP på 1 pr m²
- Gulv mot grunn eller kjeller har en BEP på 0,5 pr m²

³ I Utforming av infrastruktur som vegnett eller gatenett har også stor betydning for transportbehov og transportlengde.

⁴ Tak har et større varmetap enn yttervegger, men da isolasjonskravene her er større så settes det i BEP modellen til 1

- Vegg, gulv eller tak mot nabo har en BEP på 0 pr m²
- Alle etasjehøyder er satt til 2,7 m

I de ulike betraktninger baserer seg på en enhet på 6 x 9 m som basis enten kan være en liten leilighet på 54 m² eller som to enheter som en leilighet/hus/bolig på 108 m². BEP er i basis enheten satt til 1 eller 100%. Andre varianter og påvirkning av ulike geometriske former oppgives da som % verdi i forhold til basis verdien.

BEP standard modul

	Faktor	Antall eksponerte flater	Areal	BEP
Tak	1	1	54	54
Langvegger	1	2	24,3	48,6
Kortvegger	1	2	16,2	32,4
Gulv	0,5	1	54	27
			BEP enhet på 54 m ²	162

Basismodulen har en BEP på 162 som er satt til verdien 1 eller 100%

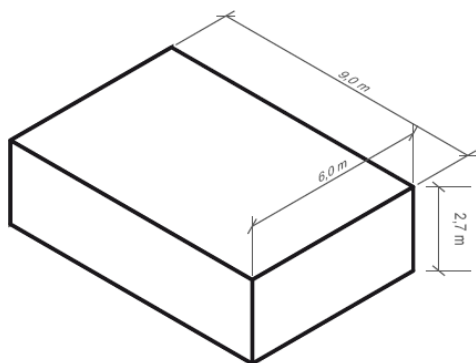

Aksonometri av basismodul

To moduler utgjør den tradisjonelle eneboligen organisert på 3 ulike prinsipp

Dette er det tradisjonelle boligen med to moduler i tre ulike kombinasjoner. Denne basistypen finnes i et utall former og varianter. Sammenligner en BEP til to moduler som er satt sammen til en enhet med BEP til to separate moduler, får en:

- Langstrakt bolig med 2 enheter på ett plan har en BEP på 90%
- Toetasjes bolig har en BEP på 65%
- Kvadratiske har en BEP på 72%.

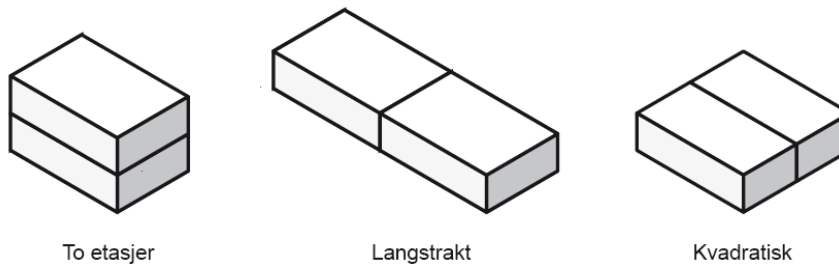

Basismoduler organisert på 3 ulike måter.

Dette viser effekt av å sette enheter sammen og med det redusere ytterflate for energitap. En ytterst enkel og selvfølgelig sammenheng, men viktig for å forstå betydningen av hvordan boliger planlegges og organiseres. Toetasjes bolig har en energieffektivitet i sin form som gjør den nesten 35% mer effektiv enn 2 stk frittstående basis enheter. Sammenlignet med avlang enebolig er den 25% mer effektiv. Toetasjes løsning møter ofte krav til universell utforming og livsløpstandard som et problem.

To boliger organisert på 3 ulike måter

BEP er her regnet ut fra toetasjes bolig som i seg selv har en BEP på 65% sammenlignet med to frittliggende basisenheter. BEP ut fra organisering av to hus er:

- Frittliggende boliger i 2 etg. er her satt til 100%,
- 2 stk Kjedehus 86 %
- 2 stk Rekkehus 80 %.

Den prosentvise endring refererer seg her til effekt av organisering. Det er stor forskjell på energibehovet for de tre ulike måtene å organisere bebyggelsen på. Effekten er meget klar allerede ved to hus. Øker en antall enheter fra 2 til 6 stk blir denne effekten bare større:

- Frittliggende boliger er her satt til 100%,
- 6 stk Kjedehus 60 %
- 6 stk Rekkehus 50 %.

Den frittliggende eneboligen er en lite energiøkonomisk form.

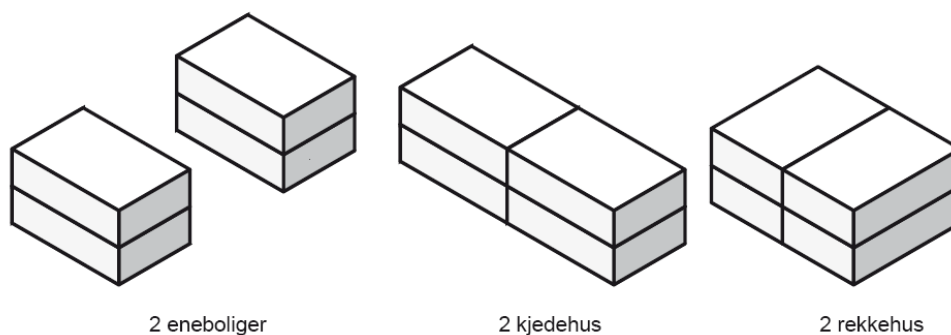

To boliger organisert på 3 ulike måter.

Egenskaper til layout av boligområder

På samme måte som form og organisering av den enkelte bolig påvirker energibehovet og muligheten for å møte kravene til et passivhus, så vil måten å organisere byspredning, de ulike feltutbygginger, jordvern og den lave tetthet en finner i periferien vil alle påvirke energibehovet. Det blir da for enkelt kun å se på den enkelte bolig, men en må også se på den samlede organisering og de energibehov dette utløser. Et passivhus blir en symbolsak hvis den ligger på et sted som er veldig transportkrevende med tilhørende stor og dyr infrastruktur. En må i tilnærmingen til passivhus se på de samlede egenskaper og energiforbruk. Store områder med lav tetthet lar seg vanskelig kompensere med mindre områder med stor tetthet.

Trondheim og byspredning

Ser en på den voldsomme byspredning etter 1950 så har byen doblet lengde på vegnett og teknisk infrastruktur pr innbygger. I denne perioden 1970 – 2000 hadde kommunen av en eller annen årsak en "uforklarlig dårlig" økonomi. I perioden 1975 til 2000 var befolkningsøkningen i byen fraværende. Arealøkningen i denne perioden besto av standardheving (større boliger og flere m²pr person) og skillsmisser (ett boforhold ble til to). De høye skillsmisse tall er en viktig årsak til boligbygging de siste 30 år og er også en viktig årsak til reduksjon av snittstørrelsen på boliger. Trondheim anno 2008 er bilavhengig og en vil få store problemer hvis bilen skulle opphøre og eksistere. Siden 2000 har det igjen vært en realvekst i Trondheim.



Trondheim i fire utviklingstrinn. 1850, 1900, 1950 og 2000. Arealforbruket økte voldsomt etter 1950

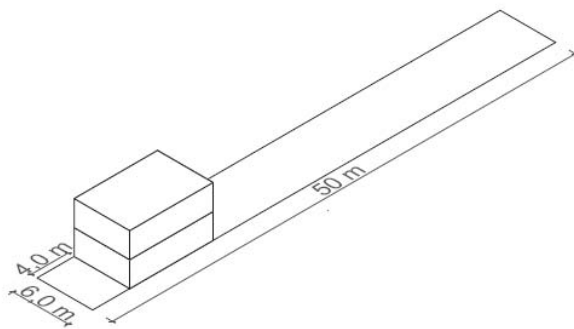
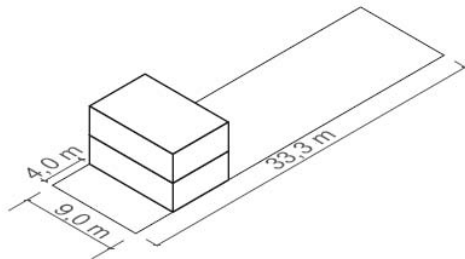
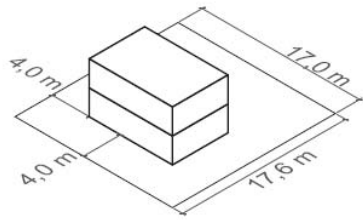

Skisse med hus og tomt der lengden av veg pr hus er poenget. Tomta er på 300 m² i alle eksempler.

Smale dype tomter

Hvis de frittliggende, kjedehus og rekkehus har samme tomtestørrelse blir organiseringen i forhold til arealforbruk og med det størrelse på infrastruktur (og med det transportbehov) tydelig.

Tar en samlet energiregnskap inn i passivhus begrepet blir infrastruktur lengde en viktig del av den miljømessige betrakning.

- Enebolig har 17 m veg eller 100%
- Ett kjedehus har 9 m veg eller 52%
- Ett rekkehus har 6 m veg eller 44%

Smale tomter gir størst avstand mellom naboer for en gitt tetthet

Smale dype tomter har i tillegg til lavere energiforbruk, mindre transport også en større frihet til orientering i forhold til sol/skygge. Denne modellen er vanlig på hele kontinentet, mens svært lite benyttet i Norge. I regnestykket er basistomten satt til 300m².

Avstand mot nabo fra hovedfasade med en tomt på 300m² er:

Frittliggende enebolig 15 meter
Kjedehus har 46 meter eller over 300%
Rekkehus har 74 meter eller 500%

I alle regnestykkene er det forutsatt 4 meter forhage mot veg. Det er enkelt å planlegge store åpne arealer med en tomtestørrelse ned i 300m² pr bolig.

Frittliggende enebolig er iboende lite arealeffektiv, gir konflikter mot naboer (kort avstand) og lite energioptimal.

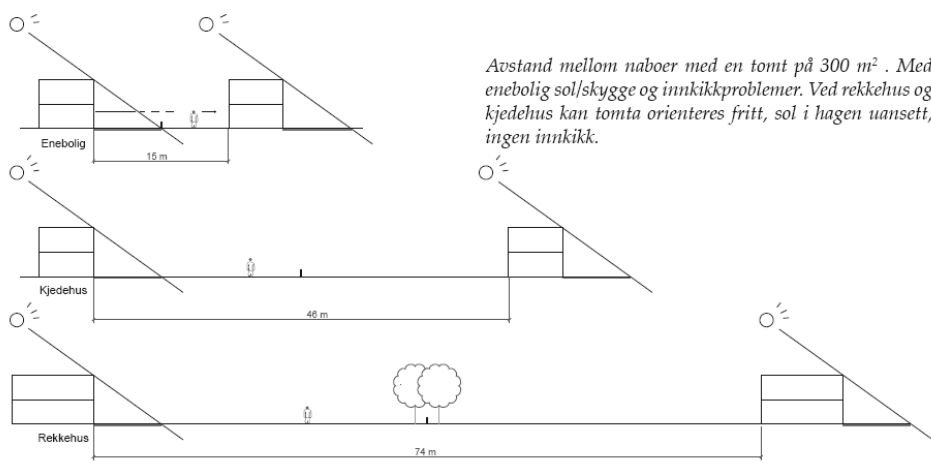

Avstand mellom naboer med en tomt på 300 m². Med enebolig sol/skygge og innkikkproblemer. Ved rekkehus og kjedehus kan tomta orienteres fritt, sol i hagen uansett, ingen innkikk.

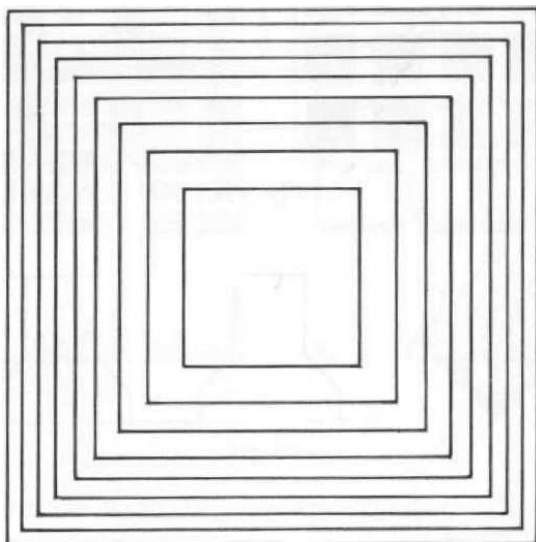

Fresnell diagram (Leslie Martin & Lionel March – 1975)



Smale dype tomter med stor tetthet og stor åpenhet
(Bilde Google Earth fra Aberdeen)

Kvartalet som energieffektiv form

Hver "sirkel" har det samme areal som kvadratet i midten. Hver ring blir smalere og smalere, men alle har samme areal. Forståelsen av denne sammenheng preger hvordan bebyggelsen mest mulig effektiv plasseres på et gitt område, dvs i periferien.

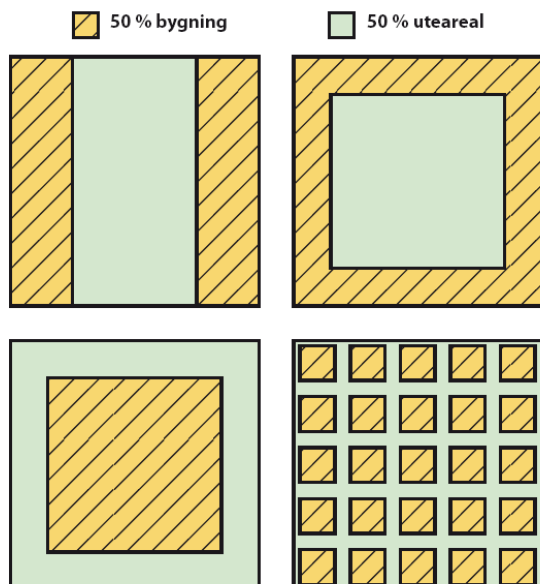

Figur som viser TU med ulike plasseringsprinsipp.
Figuren viser TU på 50%.

Tomteutnytting: form og egnethet

Hvordan bygningsmassen plasseres ut påvirker et gitt areal påvirker bomiljø og opplevd åpenhet.

Den historiske modell med karré er en kvartalløsning med bebyggelse i randsonen er den formen som gir størst åpent areal for en gitt tetthet.

I betraktninger av kvartaler så benyttes den gamle plan og bygningslov av 1845 med senere revisjoner der maksimum lengde på et kvartal er satt til 70 meter som et utgangspunkt. Årsaken til denne maksimum størrelse var ønsket om å unngå sekundærbebyggelse inne i kvartalene (Berlinerkvartal). I regnemodellene er kvartalene satt til 54 x 54 meter.

De ulike kvartal har det samme antall enheter og samme grunnflate 54 x 54 m.

Vi ser på 4 modeller:

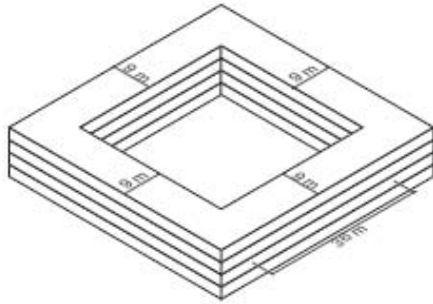

- 4 etg karebebyggelse. Dybden er 9 meter. Avstand til nabo er 36 m
- 2 lameller med 6,5 etg. Lameller har dybde på 9 meter. Avstand til nabo er 36 m men redusert kvalitet på lys/skygge grunnet økt antall etasjer.
- 3 lameller med 4,5 etasjer. Lamellen har dybde på 9 meter Avstand til nabo er 13,5 meter
- 1 Høyblokk med 20 etasjer. Lamell har dybde på 9 meter og 6 enheter pr etasje. Avstand til gate 18 m

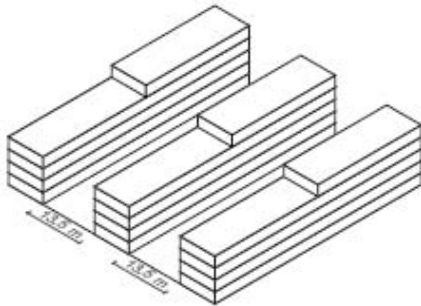

Vi tar ikke hensyn til trapperom, svalganger og andre løsningsvarianter. Vi ser her kun på det samlede volum og dets iboende potensiale. Alle eksempler har 120 enheter.

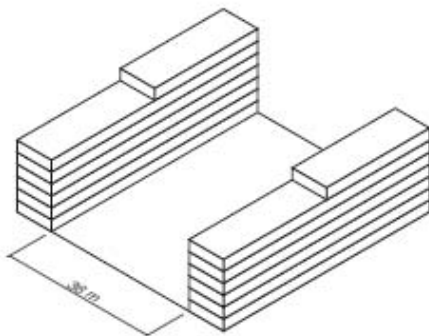

Lamell varianten har en mindre økning i antall etasjer til 4,5/6,5 avhengig av antall lameller for å få samme arealeffektivitet som et karré. Lamellen har en økt opplevd tetthet da avstanden til nabohus er redusert fra 36 til 13,5 meter ved 3 lameller og reduserte lysforhold gjennom økt antall etasjer. Lamellen med ideen om lys luft og grønne lunger har en iboende lavere åpenhet enn en karré da den orienterer seg mot neste lamell og ikke en plass (kfr Fresnell diagrammet). Hestesko formen er i så henseende en bedre kombinasjon for å oppnå åpenhet.

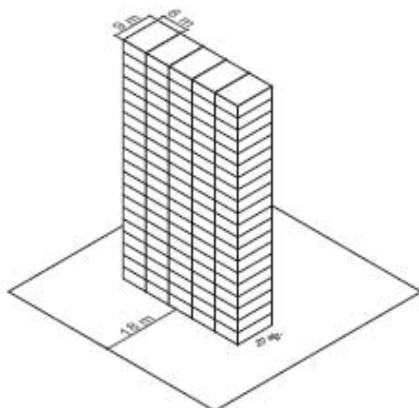

Høyhuset på 20 etasjer har ikke større tetthet enn 4 etg karré. Høyhus er iboende lite arealeffektive. Figuren viser et høyhus på 20 etasjer og forklarer hvorfor høyhus aldri har slått igjennom, de er for ineffektive for gi en reell økt tetthet. Hvis høyblokken hadde samme grunnflate som tverrsnittet i karéen ville høyblokken ha vært 40 etg høy.

BEP er også her forskjellig i de 3 variantene:

- 4 etg karebebyggelse. BEP er i dette kvartalet satt til 100%.
- 2 lameller med 6,5 etg. har en BEP på 105%
- 3 lameller med 4,5 etasjer har en BEP på 130%
- 1 Høyblokk med 20 etasjer har en BEP på 100%

3D skisser som viser volum konsekvenser for en gitt tetthet og ulike organisatoriske prinsipp

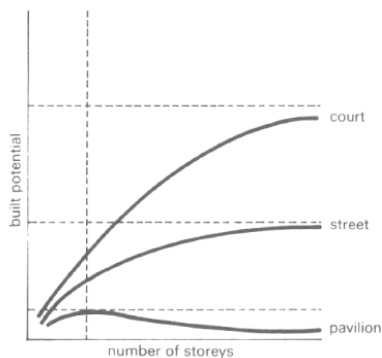

Fig. 2.4. Built potential in relation to number of storeys.

Potensiale for tetthet³

Høyblokken kommer her gunstig ut grunnet liten takflate, 3 lammeller kommer dårlig ut fra en mer ineffektiv form enn karré. 2 lameller greier seg ut i fra flere etasjer og mindre takflate. Lavest bebyggelse for en gitt tetthet oppnås med karéformen.

Punkthus, lamell/gate og karré er de tre prinsipielle organisatoriske prinsipp. Grafen viser potensialet for bebyggelse og antall etasjer der alle andre faktorer er konstant.⁵

Geometri langs en gate

I en lineær form, dvs bebyggelse langs en gate så har en et gitt tetthetspotensial av bebygdform.

Hvis man bukker på denne lineære formen (gjør den lengere) så øker en tetthetspotensialet.

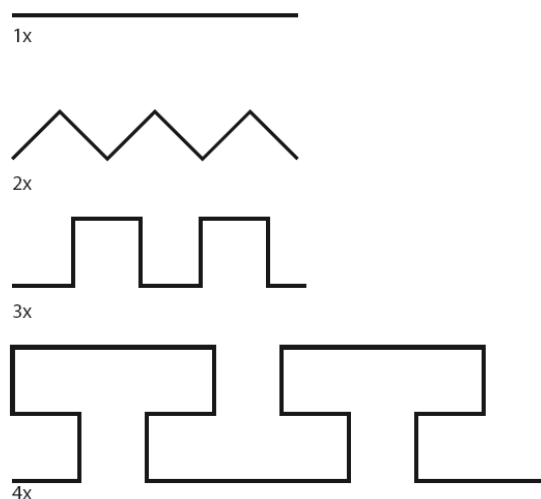

Planteegning som viser ulik grad av bukting

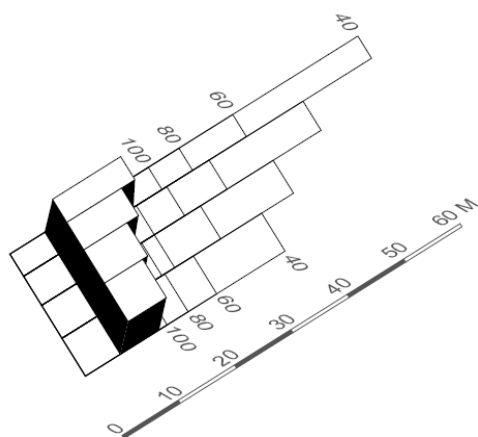

Figuren viser forskjeller på størrelsen på hager med ulike tettheter. Hus pr. hektar.

Størrelse på hagen avgjør tetthet

I dette eksemplet ser en på antall hus pr hektar. Tverrstrek i hagen viser hagestørrelser ved 100, 80, 60 og 40 hus pr. hektar.

Bebyggelsen varierer fra 4 til 7 meter i bredden. Tallene viser hus pr hektar, dvs tetthet er avhengig av størrelsen på hagen. Smale hus gir størst hagedybde for en gitt tetthet. På smale tomter gjør små justeringer i hagedybde store utslag på den samlede tetthet.

⁵ (se Leslie Martin & Lionel March i "Urban SpaceAnd Structures" for den matematiske utredning)

Konklusjon

Gjennom forståelsen av bidraget fra geometri på boligen i seg selv, sammenstilling av boliger og layout av boligfelt har en synliggjort potensialet for redusering av energiforbruk (passivhus) for en gitt konstruksjon/teknologi gjennom hvordan denne er utplassert/organisert. Med forståelse av layout, form og de iboende egenskaper kan en oppnå mange av de samme mål som passivhusene har på en annen måte.

Sammenhengende bebyggelse er den mest energioptimale måten å organisere bebyggelse på. Denne måten å organisere bebyggelse på gir også størst åpenhet (avstand til nabo) og kortest infrastruktur (mindre forurensing fra trafikk og lavere utbyggingskostnad).

Dette må også inn i plan og bygningsloven da den åpenbare ineffektivitet som preger den tradisjonelle boligfeltplanleging i Norge er lite miljøvennlig, ikke energioptimal og på lang sikt også i strid med et ønsket jordvern. Boligbebyggelse som hopper over dyrkamark som så bygges inn og etter en tid bygges ned uansett, men da med stor arealineffektivitet.

Energiøkonomisk bebyggelse er lettest å oppnå i sammenhengende bebyggelse som kjede, rekkehus og karrébebyggelse. De historiske modellene er basert på disse prinsipp ut fra ressursknapphet og energiøkonomisering. Det er først i vår tid at en kan bygge dyrt, ineffektivt og med dårlige miljøegenskaper.

Referanser

[Lionel March 1972] An Examination of Layouts – Built Environment 1972

[Dean Hawkes, Janet Owers, Peter Rickaby, Philip Steadman (Editor)] Energy and Urban Built Form - Butterworth-Heinemann - 1987

[Leslie Martin & Lionel March] – Urban Space and Structures – Cambridge University Press - 1975

[Philip Steadman] - Energy Environment and Building (Cambridge Urban and Architectural Studies) – Cambridge University Press - 1975

[Knut Selberg] – Gaten som stedsformer (Statens vegvesen fagbokserie) - 2001

Figurer

Bortsett fra hvor beskrevet er samtlige figurer tegnet av Selberg Arkitektkontor As.

Session 6

Environmental analysis and user perspective

Anna Joelsson, Leif Gustavsson

The need for a life cycle perspective on the passive house concept 162

Charlotta Isaksson

Learning to Live in a Passive House 169

**Kristina Mjörnell, Jesper Arfvidsson, Svein Ruud, Pernilla Johansson,
Joakim Norén, Lars-Erik Harderup, Anna Jarnehammar**

Framtidens trähus – Energieffektiva med god innemiljö. Future Timber
Framed Houses - Energy Efficient with Good Indoor Environment..... 171

Wiktoria Glad, Fredrik Karlsson, Kajsa Ellegård. Ewa Wäckelgård

Sociotekniska studier av lågenergihus 176

Leif Gustavsson, Anna Joelsson

Primary energy use of multi-storey wood buildings in a life cycle
perspective 184

The need for a life cycle perspective on the passive house concept

Anna Joelsson and Leif Gustavsson. Mid Sweden University, 831 25 Östersund, Sweden

Introduction

The life cycle of a building includes the production of building material, construction, operation, maintenance, and demolition (disassembly and recycling). All these phases have to be considered in order to minimize the life-cycle primary energy use and CO₂ emissions. In the existing building stock the total life cycle energy use is dominated by energy use in the operation phase [Winther and Hestnes 1999; Adalberth 2000]. Large efforts have been made to reduce the operational energy, e.g. by improved insulation, reduced leakage through the house envelope and by heat recovery of ventilation air. Such measures result in an increased material use and hence increased energy use for production, construction and maintenance. Today low-energy houses are being built, as for example so-called passive houses [CEPHEUS 2007; Passive House Institut 2007]. The focus is often on minimizing the energy in the operation phase, and the energy use of the other phases is sometimes neglected. As the energy for operation decreases, the relative importance of the other life cycle phases increases, and influences an optimization aiming at minimizing the life-cycle energy use. The life-cycle primary energy use of houses also depends on the energy supply systems for electricity and heat, including fuel, end-use heating systems and large-scale heat and power supply. The properties of these systems are significant for the primary energy use, both for the operation phase [Gustavsson and Joelsson 2007; Joelsson and Gustavsson 2007] and for the total life cycle [Zimmermann, Althaus et al. 2005].

Here, we analyse primary energy use and CO₂ emission in different life cycle phases for four residential buildings. We compare low energy buildings with older standard houses. All of them are also compared when using different types of energy supply systems.

Methodology

We have compared four Swedish buildings, including two houses and two apartment buildings. We named them after the geographical area of construction. The characteristics of the buildings are shown in Table 1. Each of the houses was evaluated for two alternatives. The Östersund house, which was built in the 1970s, was evaluated both for the original standard and for a retrofit alternative with extra insulation in the attic and foundation and new energy efficient windows. This was to show the energy efficiency potential for houses from this time-period. The Växjö apartment building was originally constructed 1996 with a mechanical exhaust air system. Here it is also evaluated with a heat exchanger with a temperature efficiency degree of 0.68 and with energy efficient windows [Adalberth 2000]. Both the Lindås house and the Karlstad apartment building were built as passive houses, but do need energy supplied for space heating. Both houses were built with mechanical supply and exhaust ventilation systems with plate heat exchangers with temperature efficiency degrees of 0.83 for Lindås and 0.5 for Karlstad. Here they are also analysed for alternatives without the heat exchangers. The fan effect of the ventilation alternatives with heat recovery was assumed to be 2.5 W/(m³/s) for all buildings. In “passive” houses the space heating demand is generally covered by electricity and Lindås has an electric battery connected to the ventilation system. However, Karlstad has a hydronic system installed, which uses water with a temperature of +35°C on return in the district heating system. The Lindås house is the Swedish contribution to the CEPHEUS project (cost efficient passive houses as European standard, project number BU/027/97).

Table 1. Characteristics of the studied buildings

House name	Type of building	Year of construction	Heated area (m ²)	Final energy demand space heating + ventilation (kWh/m ² , year)
Östersund	Detached house	1976	144	150
Östersund retrofit				119
Lindås	Row-house	2001	120	34
Lindås, passive				22
Växjö	16 apartments	1996	1190	54
Växjö retrofit				26
Karlstad	44 apartments	2006	2802	35
Karlstad passive				20

The functional unit of the analyses was one square meter of heated area per year. This enabled a comparison between these different types of buildings. We analysed the primary energy use for production and operation phases. The energy for production was based on the energy demand for manufacture and transportation of building materials, and gathered from literature describing the buildings [Thormark 2006a; Thormark 2006b; Adalberth 2000; Gustavsson, Pingoud et al. 2006]. The Östersund house was not evaluated with respect to production energy use. Energy for erection of the buildings was not included in the production phase.

The operation phase was assumed to be 50 years long and included space heating, hot water, and electricity for ventilation, household and facility management purposes. Energy use for maintenance during the building life was not included. The hot water and electricity use is not building specific but depends to a large extent on the users. Therefore the annual energy demand for hot water Q_{water} and electricity Q_{el} for each building was set to an amount of

$$Q_{\text{water}} = 1800 \text{ kWh} \cdot \text{number of apartments} + 18 \text{ kWh/m}^2 \text{ of heated area}$$

$$Q_{\text{el}} = 2200 \text{ kWh} \cdot \text{number of apartments} + 22 \text{ kWh/m}^2 \text{ of heated area}$$

This was based on estimates used by the Swedish National Board of Housing, Building and Planning. The operation phase of each building was evaluated for several types of energy supply systems for the space heating. The end-use heating systems compared were resistance heaters (RH), bedrock heat pump (HP) and district heating (DH). They were combined with electricity supply systems with coal-based steam-turbine technology (CST) and biomass-based integrated gasification combined-cycle technology (BIG/CC). For the district heating systems, cogeneration plants covered the base-load heat demand. As cogeneration generates both heat and electricity, we used the subtraction method and assumed that the electricity cogenerated in the district heating system replaced electricity produced in condensing power plants based on similar technology and with the same kind of fuel as the corresponding cogeneration plant [Gustavsson and Karlsson 2006]. The operation phase was compared also with respect to net CO₂ emission. The CO₂ released from burning biomass fuels was assumed to be balanced by the CO₂ removed from the atmosphere during the growth of new biomass. Thus, the emission of CO₂ from the biomass-based systems depended on the amount of fossil fuel used in the energy chains, for example for transportation. The calculations of the primary energy use and CO₂ emission from operation were performed with the software ENSYST [Karlsson, 2003]. It takes into account all processes in the energy chains, such as efficiencies of fuel cycles and conversion and distribution systems.

Results

Figure 1 shows the primary energy use for the production phase of five of the buildings. The low-energy buildings Lindås and Karlstad, both had substantially higher energy use for production than the Växjö building. The addition of heat exchangers in Karlstad passive, and heat exchangers and more efficient windows in Växjö retrofit, had a minor impact on the production energy.

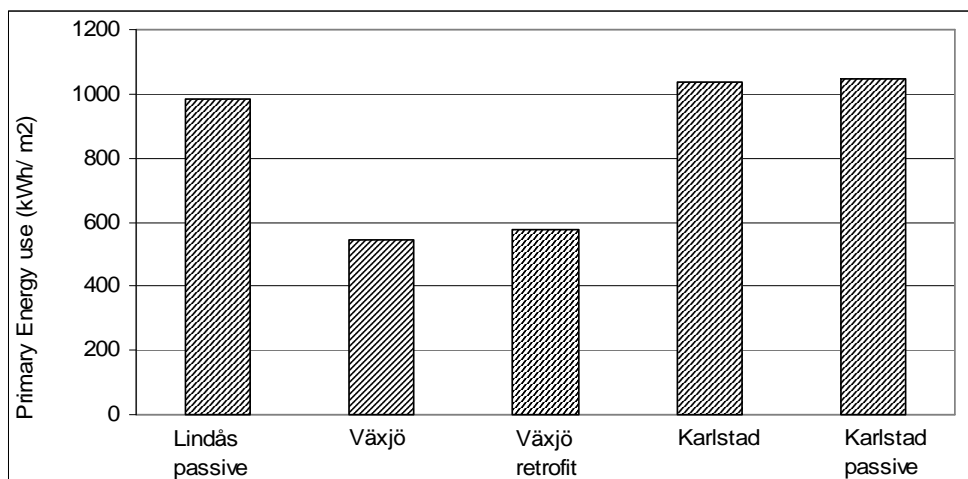

Figure 1. Primary energy use for the production of five buildings.

When the primary energy use for space heating and ventilation was included in the comparison, Lindås passive and Karlstad passive had significantly lower total primary energy use than Växjö, despite the higher energy use for production. The difference in space heat between the passive houses and Växjö retrofit was not as large as compared to Växjö, and the total primary energy use in Lindås passive and Karlstad passive was 3% and 8% lower, respectively, than in Växjö retrofit.

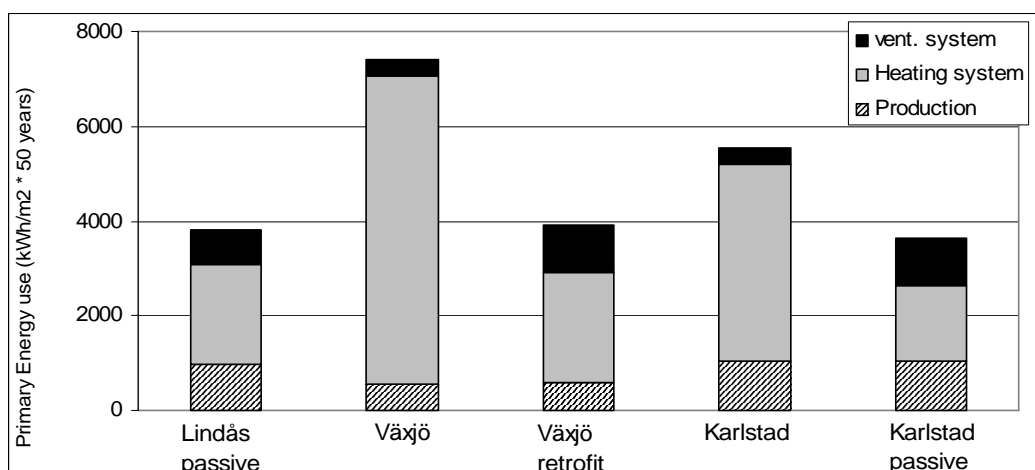

Figure 2. Primary energy use for the production and heating of the five buildings. The energy for operation was resistance heating with coal-based electricity (RH CST).

Heat recovery in the ventilation air reduced the primary energy use for operation compared with using a mechanical exhaust ventilation system. The electricity use of the ventilation system increased, but the primary energy use in the heating system was reduced more (Fig. 2).

The choice of energy supply system had an even larger impact than the energy efficiency measures on reducing the primary energy use of building operation. Figure 3 shows the primary energy use for both production and space heating of the passive houses and Växjö retrofit, using different supply systems. As stated earlier, the passive houses had lower primary energy use for space heating and ventilation than Växjö retrofit, but higher production energy use. With RH CST the large space heating energy use dominated and the passive buildings had lower total energy use. However, for the more efficient HP and DH systems the relative importance of the production energy increased, and Karlstad and Lindås passives ended up with a higher total primary energy use than Växjö retrofit.

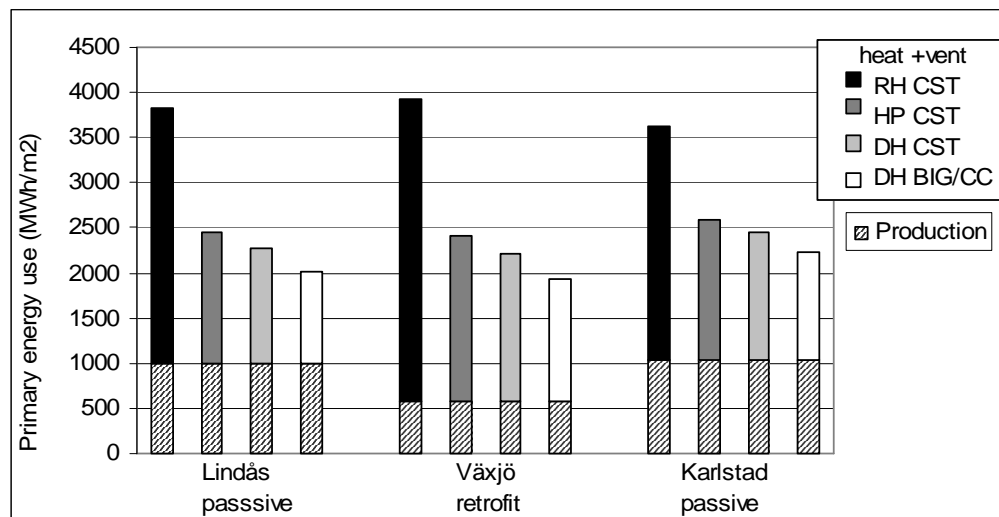

Figure 3. Primary energy use for the production and heating of three buildings with different supply systems: resistance heating (RH), heat pump (HP) and district heating (DH), with electricity based on coal (CST) and biomass (BIG/CC).

Figure 4 depicts the relation between the primary energy for production and heating for the three buildings in Figure 3. The production energy constituted a larger part of the total energy as the operational energy decreased, and was most important for the low-energy buildings. When coal-based electricity was supplied the production phase in Lindås passive and Karlstad passive was just below 30% of the total, while for Växjö retrofit it was 15%. Without the retrofits the production phase accounted for 7% in Växjö, due to the larger heat demand. However, the choice of supply system had a large impact on the heat demand and when using DH BIG/CC the production energy's part for Växjö retrofit was 29%. Choosing DH BIG/CC instead of RH CST increased the production part in Lindås and Karlstad passive to 49% and 47%. The results showed that the importance of the production energy increased at reduced operational energy both due to more efficient buildings and more efficient supply systems.

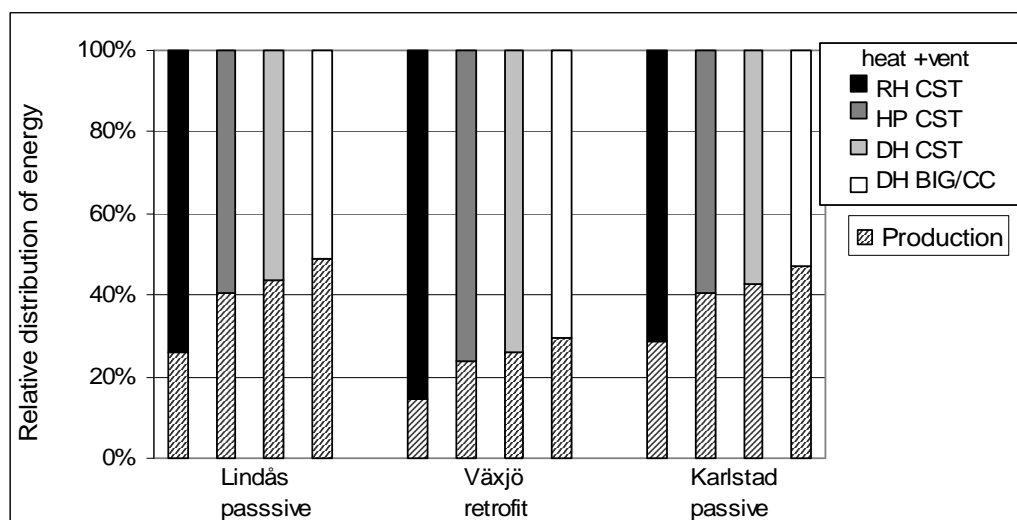

Figure 4. The relative distribution of primary energy use for the production and heating of the buildings with different supply systems. Abbreviations as in Figure 3.

When including also the non-building specific energy use for hot water and household electricity in the operational phase, the production energy constituted a significantly smaller part of the total energy, also for the low-energy building. The production energy was 4% of the total primary energy use for Växjö retrofit with RH CST and constituted at the most 13%, for Lindås passive with DH BIG/CC (Fig 5). Hot water and household electricity constituted the largest part of the operation energy and both of them were larger per heated area in

Karlstad, since the building had smaller apartments. Therefore the ranking of the total primary energy use is different in Figure 5 compared to Figure 3, for Karlstad passive and Väjö retrofit with RH CST.

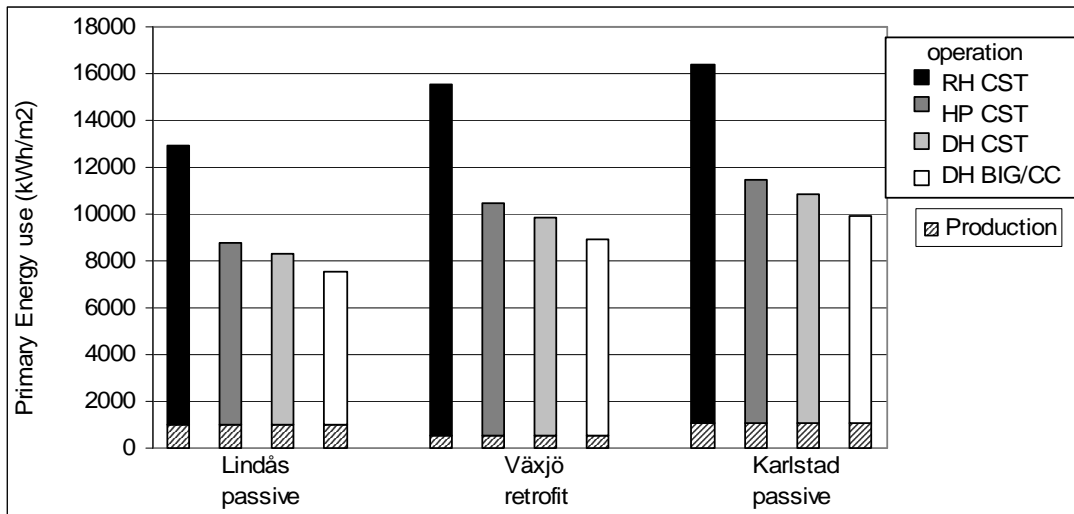

Figure 5. Primary energy use for the production and operation of three buildings with different supply systems as in Figure 3.

The choice of supply systems had a large impact on the total life cycle primary energy. Implementing the retrofit measures in the single-family house Östersund (Östersund retrofit) resulted in 14% lower primary energy use. Choosing biomass-based district heating (DH BIG/CC) instead of resistance heating with coal-based electricity (RH CST) resulted in 70% lower primary energy use for Östersund. Figure 6 shows the primary energy use for operating six building alternatives, with different supply systems for heat and electricity. District heating and heat pumps was clearly more energy efficient than resistance heating. Using district heating and heat pumps in the Väjö and Östersund houses resulted in lower primary energy use than in Lindås passive when it was using resistance heating. For biomass-based district heating the primary energy use was 30% and 36% lower, respectively, in Väjö and Östersund retrofits than in Lindås passive.

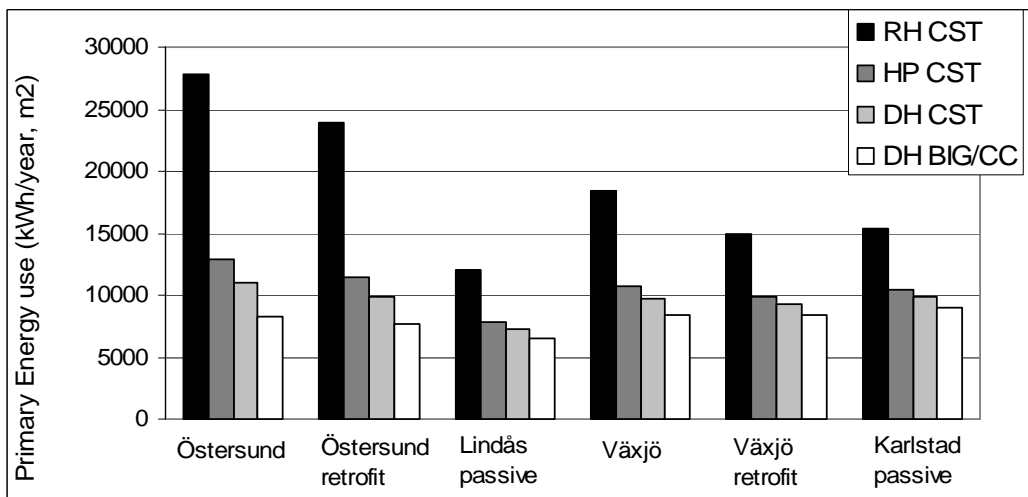

Figure 6. Primary energy use for operating the buildings with different supply systems. Abbreviations as in Figure 3.

When using more efficient supply systems the difference in primary energy use between the buildings was smaller. The choice of energy supply system actually affected the primary energy ranking of the buildings. When using RH CST, Väjö retrofit clearly had a smaller primary energy use than Väjö. However when the electricity supply was biomass-based (BIG/CC), and the heat demand was covered with cogenerated district heating (CHP BIG/CC) Väjö retrofit had slightly higher primary energy use than Väjö. When installing the heat exchangers, the demand of heat to be covered by the heating system decreased, but the electricity use for

the ventilation system increased. The electricity demand was covered by stand-alone BIG/CC (efficiency of 47%), and the increase in primary energy use for the electricity was larger than the decrease for heating.

The CO₂ emission from the operation depended heavily on the fuel used in the supply systems. The biomass-based system had the lowest emission. The Östersund retrofit using DH BIG/CC had CO₂ emissions that were 90% lower than Lindås with RH CST (Figure 7).

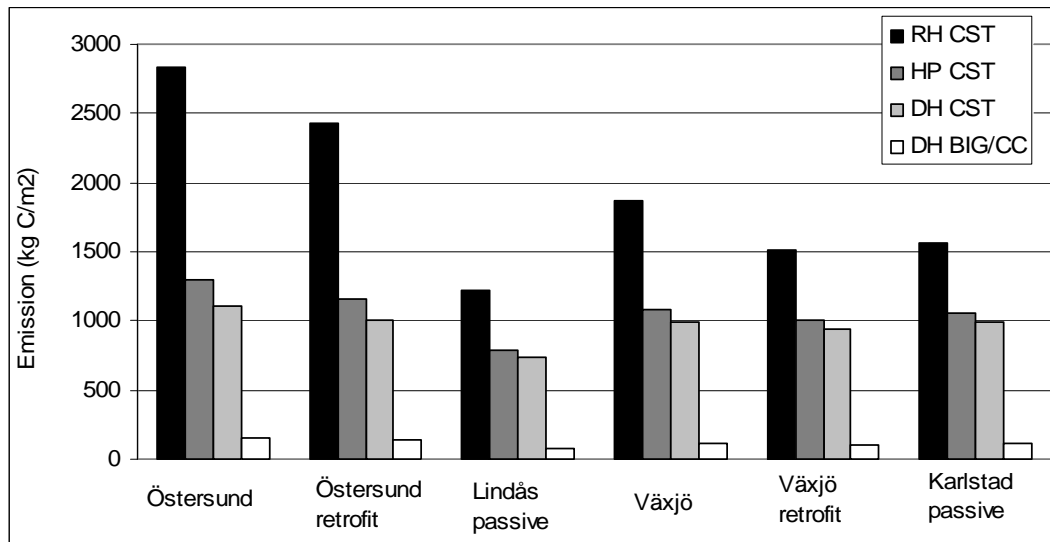

Figure 7. CO₂ emission for operating the buildings with different supply systems. Abbreviations as in Figure 3.

Discussion and conclusions

The primary energy use for production was small compared to the total operational energy for all studied buildings. This indicates that even for low-energy buildings, the operational energy is dominant. However, a large part of the operational energy was used for hot water and household/building electricity. In a discussion on building construction these parts are of less interest, since they have a minor dependence on the building construction itself. When comparing the production energy to the energy use for heating and ventilation, the production energy constituted a significant part for the low-energy buildings during a 50-year time span. We therefore need a life cycle perspective to optimise the energy use in buildings, and all significant life cycle phases should be included.

The operational primary energy could be substantially reduced by energy efficiency measures, both in the old single-family house and the 12 year old apartment building. Such measures in existing buildings are therefore important. However, the choice of heat supply system had a much larger effect and could reduce the total primary energy use by 70%. The cogenerated district heating was shown to be the most efficient system, and biomass-based systems strongly reduced CO₂ emissions. These measures implemented in the 1970s house proved to be as effective in reducing primary energy use and CO₂ emissions as constructing a new passive house. The relative importance of the production energy was also higher when using more energy efficient supply systems for heat and electricity. This was possible to show because the primary energy use was considered, and not only the final heat demand of the buildings. Analysing the primary energy use showed the impact of the supply systems for the entire life cycle energy use. We therefore conclude that when optimising the energy use of buildings, a life cycle perspective on the energy supply is also necessary.

References

- Adalberth, K, Energy use and environmental impact of new residential buildings. Department of Building Physics. Lund, Lund Institute of Technology, (2000)
- Adalberth, K, Energy use in Four Multi-Family Buildings During their Life Cycle, *International Journal of Low Energy and Sustainable Buildings* (2000)
- CEPHEUS, Cost Efficient Passive Houses as European Standards, (2007)
- Gustavsson, L. and Joelsson A, Energy conservation and conversion of electric heating systems in detached houses, *Energy and Buildings* 39(6): 716-726, (2007).
- Gustavsson, L. and Karlsson, Å, CO2 mitigation: On methods and parameters for comparison of fossil-fuel and biofuel systems, *Mitigation and Adaptation Strategies for Global Change* 11: 935-959, (2006)
- Gustavsson, L., Pingoud, K, et al. Carbon dioxide balance of wood substitution: comparing concrete- and wood-framed buildings, *Mitigation and Adaptation Strategies for Global Change* 11: 667-691, (2006)
- Joelsson, A. and Gustavsson, L, District heating and energy conservation in detached houses of differing size and construction. 3rd International Green Energy Conference, Västerås, Sweden, (2007)
- Karlsson, Å, ENSYST. Lund, Lund University, (2003)
- Passive House Institute, Welcome to the Passive House Institute, (2007)
- Thormark, C, The effect of material choice on the total energy need and recycling potential of a building, *Building and Environment* 41: 1019-1026, (2006)
- Thormark, C, Resursanvändning i ett 12-vånings lågenergihus utan värmesystem. Lund, Lund University, Division of construction management, (2006)
- Winther, B. N. and Hestnes, A. G, Solar versus green: The analysis of a Norwegian row house, *Solar energy* 66(6): 387-393, (1999)
- Zimmermann, M, Althaus, H-J et al. Benchmarks for sustainable construction. A contribution to develop a standard, *Energy and Buildings* 37: 1145-1157 (2005)

Learning to Live in a Passive House

- The households' activity to create a comfortable indoor temperature

Charlotta Isaksson
Department of Technology and Social Change
Linköpings University
581 83 Linköping
Sweden
chais@tema.liu.se

"I think you have to learn living in a house like this" one of the informants told me when she described efforts of heating the passive house during the first winter. The aim of this study is to present how the learning process was shaped when the households tried to understand how to manage the space heating in the practice of everyday life. The results introduced here are mainly empirical, but they are grounded in a theoretical approach that is built upon Vygotsky's work. Vygotsky describes learning as an integrated part of every human practice and it is a process which we humans try to make use of and understand through different types of mental or physical tools. To accomplish a comfortable indoor climate there are different resources available, such as technology, oral or written information. The main motivation to learn about the space heating is the lack of comfort and the goal is to create a comfortable indoor temperature.

The study is based on qualitative interviews with occupants living in the first passive houses built in large scale in Sweden. The interviews have been carried out in two rounds (2002 and 2005) with 16 respectively 15 households. The buildings, built in 2001, are situated south of Gothenburg and consist of 20 terraced houses divided into four blocks.¹ The building construction is very well insulated and the ventilation system is equipped with an efficient heat exchanger. A 900 W integrated heater in the supply air, covers some of the space heating demand during cold periods, but most heat is gained from appliances, body heat and solar irradiation.

In the second round of interviews, the space heating was often described as something easily managed. The work involved was small and it was perceived as convenient. Some used only the integrated heater, others installed extra radiators, while a few did not use any additional heating at all. A majority were quite satisfied with the indoor temperature during the winter. However, it has not always been like that. In fact, it was more difficult to heat the house during the first winter. Many blamed the building moisture or the cold weather, while others pointed out a technical defect in the air heating system. When analysing the empirical material, however, it became apparent that the lack of knowledge about how these passive houses worked in practice was also an important issue.

Learning about the space heating often occurred by passing through different elements of problemsolving. The householders were confronted with problems or issues that felt unclear, which they then tried to identify and solve. It often dealt with the function of the air heating system, when and in what way it should be used under different conditions; how it worked in a passive house context where gains received from appliances, body heat and solar irradiation alternated. In this process, they tried to make use of heterogeneous resources; different kinds of written information, meetings where they were informed about the space heating, conversations with neighbours and interaction with the air heating system, often in a procedure of trial and error. However, all resources were not used or useful for everyone. For instance, the written technical information was not very often read or correctly understood.

Over time, the households alternate both attitudes and their use of energy intensive technology in relation to them becoming masters over resources and their growing experiences of living in a passive house. This process of learning is far from unique, but when a product (such as the passive house) is the first of its kind on the market it is to a larger extent surrounded with uncertainty - making it more complicated for those involved. Finally, the conclusion is that a complete evaluation of the performance of passive houses (or for that matter,

¹ When both interviews were carried out, one of the houses was uninhabited since the Swedish National Testing and Research Institute (SP) used it for research purposes.

any other type of building), should preferably not be done during the first year. Instead we need to develop ways of guiding and helping to solve some of the problems that occur - whether it concerns technical devices or user-issues. Furthermore, with better methods - the knowledge acquired by the householders can be used to a much greater extent.

The results will be further presented in a forthcoming paper, *Learning Energy Technology in Practice, the activity to create a comfortable indoor climate in passive houses*, by Isaksson and Gyberg.

Framtidens trähus – Energieffektiva med god innemiljö. Future Timber Framed Houses - Energy Efficient with Good Indoor Environment

Kristina Mjörnell, SP Technical Research Institute of Sweden (Building physics and indoor environment)
Jesper Arfvidsson, Lund University (Building physics)
Svein Ruud, SP Technical Research Institute of Sweden (Energy and systems)
Pernilla Johansson, SP Technical Research Institute of Sweden (Building physics and indoor environment)
Joakim Norén, SP Technical Research Institute of Sweden (Timber technology)
Lars-Erik Harderup, Lund University (Building physics)
Anna Jarnehammar, IVL (Environmental technology)

Abstract

The Swedish building regulation that came in force in July 2006 requires new systems for heating and ventilation of buildings as well as improved design of the building envelope. When introducing energy efficient systems for heating and ventilation it is important to assure air tight building envelopes and moisture safe building elements in order to maintain a good indoor environment. The overarching aim of the project is to support the timber house industry to develop outlines for the future timber framed houses to meet the requirements on low energy use, low environmental impact, durability, moisture safety and good indoor environment, for example high thermal comfort and good indoor air quality, and aesthetic wooden floors without gaps and lifting. The approach is to gather researchers in the field of timber technology, building physics, indoor and outdoor environment, energy and building services engineering and involve them in the process of design and construction of four different types of timber framed houses, tree one-family houses and one multifamily house. The work is performed in cooperation with a number of companies. Four companies will develop and build pilot houses with technical support from the research group. These houses will be followed up by measurements of environmental impact, energy use, moisture in building elements, air-tightness, indoor air quality, thermal comfort and movements and dilations caused by moisture. In addition, a number of tools will be developed to support the companies in their work. This can be for example calculation tools for heat, moisture and energy or checklists to be used in the design and construction stage.

Introduktion

Trähusbyggandet har en lång tradition i norra Europa. Trä har med gott resultat i århundraden använts i ytterväggar, tak och golv. Men på grund av allt högre krav att minska energianvändningen för uppvärmning av byggnader har byggnadsskalet och ventilationssystemet förändrats drastiskt under de trettio senaste åren. Åtgärder, som tjockare värmeisolering, nya typer av byggnadsmaterial samt reducerad ventilation eller modifierad ventilation påverkar byggnaders termiska och hygroskopiska egenskaper. Detta har ibland resulterat i nedbrytning av träkomponenter och fuktskador i byggnader i form av missfärgning, mögelpåväxt och ibland rötskador. Befintlig kunskap om byggnaders termiska och hygroskopiska egenskaper baseras på erfarenheter, simuleringar, mätningar av traditionella byggnader under lång tid men kan tyvärr inte användas rakt av vid utformning av nya sk lågenergibygnader. Ett antal konstruktioner, som vi vet är fuktkritiska redan i de traditionella byggnaderna kommer att bli ännu mer känsliga i lågenergihusen. Andra viktiga faktorer som påverkar byggnadernas beständighet är att våra levnadsvanor förändras, vilket leder till ökad inomhustemperatur och ökat fukttillskott, vilket i sin tur leder till en ökad belastning på byggnaden. På grund av allt högre temperaturnivåer inomhus blir den relativa fuktigheten mycket låg under uppvärmningssäsongen vilket kan leda till sprickbildning till följd av att trämaterial krymper. Å andra sidan får fuktproduktionen, till följd av duschning, matlagning, tvätt etc. stor betydelse i byggnader med låg ventilationsgrad. En hög ånghalt inne ökar risken för fuktproblem i byggnadsskalet.

Övergripande mål

Det övergripande målet i projektet är att stödja bygg- och trähusindustrin inför omställning till kraven i BBR rörande energianvändning och fuktsäkerhet. De nya kraven kommer att kräva användning av nya kombinationer av system i syfte att minska energianvändningen och i viss mån nya konstruktionslösningar för att klara fuktsäkerheten. I Sverige sker under 2006-2010 en satsning på träbyggande vilket har för avsikt att förnya och öka träbyggandet med nya produkter och tillverkningsmetoder med industriella förtecken. Denna satsning medför mycket ny teknik som behöver utvärderas innan den används i stor skala. Syftet med projektet är att tillsammans med industrin utveckla och utvärdera system och konstruktioner som inte medför några negativa effekter på inomhusmiljön och byggnaders funktion i övrigt. Målgruppen för detta projekt är främst projektörer, byggare och trähustillverkare samt deras underleverantörer.

Projektupplägg

Angreppssättet i projektet är att samordna de goda kompetenser, inom relevanta discipliner, som finns i landet och skapa möjligheten att ta ett helhetsgrepp på trähusbyggandet i Sverige avseende energieffektivitet och inomhusmiljö. Detta skall ske i nära samverkan med deltagande företag i syfte att utveckla hjälpmedel i form av beräkningsverktyg för värme och fukt och energi samt checklistor för det löpande arbetet samt stödja och följa upp fyra trähusbyggnader, ett flerbostadshus och tre småhus. Dessa objekt skall utgöra goda exempel på energieffektiva bostäder med god inomhusmiljö som klarar kraven i de nya svenska byggreglerna.

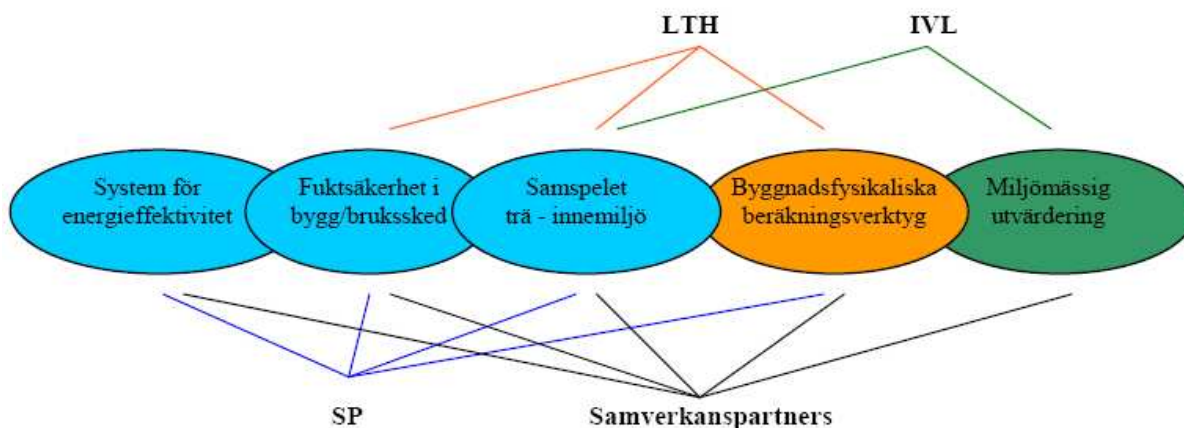

Figur 1: Projektet består av fem delprojekt med kopplingar till utförande organisationer och samverkanspartner.

Projektet består av fem delprojekt. Som i samverkan skapar den helhet som är nödvändig för projektets genomförande. Nedan ges en kort beskrivning av varje delprojekt.

Delprojekt 1 - System för energieffektivitet och bra inomhusmiljö i trähus

Syfte

Syftet med delprojektet är att få ökad kunskap om hur trähus kan göras energieffektivare med bibehållen eller förbättrad inomhusmiljö, inkluderat luftkvalitet. Detta skall undersökas genom att följa upp energianvändning och inomhusmiljö i olika typer av energieffektiva trähus (från BBR-till Passivhusstandard). I projektet kommer lösningar att tas fram för att förbättra befintliga uppvärmnings- och ventilationssystem så att de blir bättre anpassade för användning i välisolerade och täta träkonstruktioner. Man kommer att studera för- och nackdelar med behovsstyrd ventilation och fuktåtervinning i relation till relativa fukthalter och luftkvalitet, utveckla och förbättra system för kontroll och säkerställande av att en korrekt tryckbalans upprätthålls över byggnadskonstruktionen samt ge anvisningar och vidareutveckla hjälpmedel för tätning och täthetsmätningar.

Metod och genomförande

Delprojektet är indelat i följande tre huvudmoment:

1. Litteraturgenomgång; isolerstandard, täthet, installationer, inomhusmiljö och energieffektivitet för olika typer av trähus fram till idag, "Från massivhus till passivhus"
2. Simuleringar och fältstudier av hur olika typer av systemlösningar (isoleringsgrad, täthet, värme, ventilation, styr- och reglerteknik) påverkar energianvändning, relativa fuktigheten, termisk komfort och luftkvalitet.
3. Utvärdering, slutsatser samt spridning av resultat

Delprojekt 2 - Fuktsäkerhet i bygg- och bruksskedet

Syfte

Syftet är att undersöka vilka fuktförhållanden, uttorkningstider och uppfuktningstider som trämaterial utsätts för vid lagring, transport och på arbetsplatsen med hänsyn till nederbörd, årstid, antal uppfuktningstillfällen, uttorkningsåtgärder etc. i ett antal typfall. Trä är ett material som är känsligt för påväxt av mögel om det utsätts för fukt. Det kritiska fuktillståndet för trä är ca 75 % men beror även på temperaturnivån och varaktigheten. Under byggtiden och i den färdiga konstruktionen kommer trä att utsättas för olika långa perioder av uppfuktning och uttorkning. I delprojektet kommer man att undersöka hur tillväxten av mögel sker i olika klimat (relativa fuktighet och temperatur) med olika varaktighet. Syftet är också att undersöka fuktrelaterade rörelser i virket som uppkommer när trä som utsätts för höga fuktigheter torkar ut samt definiera vad som är acceptabelt fuktillstånd med avseende på såväl mikrobiell tillväxt som formförändringar vid olika uppfuktning- och uttorkningsförhållanden.

Metod och genomförande

I detta delprojekt kommer verkliga fuktförhållanden att kartläggas. Ett antal pågående byggprojekt besöks och fuktförhållandena dokumenteras. Fuktbelastningen i ett antal väggelement uppmäts från fabrik till färdig byggnad. Klimatet i ett antal provhus kommer att följas på de ställen där det värsta klimatet förväntas i konstruktionen. Tillväxten av mögel på trä kommer att undersökas i laborieförsök. Proverna exponeras först för mögelsvampsporer och placeras därefter i kontrollerade klimat. Dessa kommer att motsvara de som uppmäts i fält. Det som kommer att studeras är hur eventuell påväxt av mögelsvamp utvecklas under tiden. Fuktberoende formförändringar hos olika typer av mekaniska förband med tvärkraftsbelastade förbindare kommer att göras i korttidsförsök. För varje typ av förband genomförs tre försöksserier där två serier är uppfuktade till olika fuktkvoter och ett är ett referensprov utan uppfuktning. Dessutom studeras hur utdragshållfastheten hos axialbelastad spik i virke påverkas av en initial uppfuktning.

Resultat

Resultaten från projekten förväntas leda fram till definitioner av vad som är acceptabelt fuktillstånd med avseende på mikrobiell tillväxt och formförändringar vid olika uppfuktning- och uttorkningsförhållanden. Rekommendationer för hantering av trä i byggprocessen kommer att formuleras, liksom anvisningar och rekommendationer för fuktsäkerhetsprojektering av byggnadsdelar för träbaserade material.

Delprojekt 3 - Samspelet trä-innemiljö

Syfte

Syftet med projektet är att både beräkna och experimentellt utvärdera effekten av ett antal olika kombinationer av energisparande åtgärder som alla skall möjliggöra en viss styrning av inomhusmiljöns kvalitet avseende relativ luftfuktighet, koldioxid, föroreningar och emissioner etc. Ett sätt att styra inomhusklimatets kvalitet är genom varierande luftomsättning med brukandet som styrande parameter. För träprodukternas funktion i inomhusmiljön är det viktigast att öka den relativa luftfuktigheten inomhus vintertid från extremt låga nivåer kring 10 – 20 % till cirka 30 %. Med träprodukternas funktion avses här t.ex. fuktrelaterade rörelser såsom svällning/krympning, kupning, spring och sprickbildning etc.

Metod och genomförande

Metoden i projektet bygger på en inledande probleminventering följt av experimentella studier som huvudsakligen görs i fullskala men även till mindre delar i laboratorium. Probleminventeringen består i att gå igenom och sammanställa tidigare utfört arbete samt att intervjua några aktörer inom branschen t.ex. trähustillverkare, byggare och materialleverantörer. De fullskaliga experimenten utförs i bebodda provhus/lägenheter i nära samverkan med deltagande företag. Provhuset kommer att utvecklas, projekteras och byggas huvudsakligen av deltagande företag. Provhuset kommer att instrumenteras med olika typer av sensorer för luftfuktighet, temperatur, koldioxid, fuktrelaterade rörelser etc. Mätningarna i husen kommer att pågå under två år efter inflyttning. Avsikten är att prova olika kombinationer av tekniska lösningar för ventilation och uppvärmning samt dess effekter på inomhusklimatet och träprodukternas respons i provhusen. Målsättningen är att minska variationen i relativ luftfuktighet inomhus under en årscykel. Exempel på tekniska lösningar som skall utvärderas är behovsanpassad ventilation och värmeväxlare för ventilation med fuktåtervinning. Utvärderingen inriktas huvudsakligen på luftomsättningens och fuktåtervinningens inverkan på relativ luftfuktighet, koldioxid, föroreningar och emissioner. Parallellt med arbetet att minska klimatsvängningarna i provhusen utvecklas och anpassas några träbaserade byggprodukter t.ex. lamellparkett, konstruktionsvirke och träbaserade skivor i syfte att göra dem mer formstabila avseende fuktrelaterade rörelser.

Delprojekt 4 – Byggnadsfysikaliska beräkningsverktyg

Syfte

Syftet med denna del av projektet är att skapa en ”verktygslåda” med användarvänliga verifierade beräkningsverktyg för värme och fukt. Möjligheten att på ett beräkningsmässigt enkelt sätt kunna hantera värme- och fuktförlopp ökar kunskapen om samt förståelsen för dessa processer. Med sådana hjälpmedel ökar möjligheten för att bygga energieffektiva och fuktsäkra hus med god inomhusmiljö.

Metod

Delprojektet omfattar både forskning och utveckling. Mycket av programmeringsarbetet av användargränssnittet är utvecklingsarbete. Matematiska och numeriska modeller för icke linjära värmeledningsberäkningar med hjälp av Kirchoff potentialen samt icke linjära fuktförlopp i anisotropa material såsom trä ligger inom forskningsdelen. Utvärderingen av ”verktygslådan” kommer att genomföras på ett vetenskapligt sätt och ligger således inom forskningsdelen av projektet.

Genomförande

Projektet genomförs som ett doktorandprojekt som består av följande delar:

1. Genomgång och val av existerande program som ska ingå i ”verktygslådan”.
2. Utveckling av nya beräkningsverktyg. Modeller för att beräkna fukt- och värmetransporten i konstruktioner utvecklas. Utifrån dessa skapas användarvänliga beräkningsprogram för specifika problemställningar (av typen TorkaS).
3. Verifiering av beräkningsverktyg mot mätningar.
4. Test av ”verktygslådan” hos deltagande företag.
5. Utvärdering, slutsatser samt spridning av resultat.

Genomgång av existerande program, samverkan och samråd med övriga delprojekt och deltagande företag samt litteraturgenomgång har påbörjats.

Delprojekt 5 – Miljöbedömning

Att spara energi och bekämpa en förstärkt klimatförändring är två centrala frågor inom EU. Byggssektorn har pekats ut som den bransch som enskilt har störst potential till energieffektiviseringar. EU har därför infört en rad regleringar och direktiv inom området, t.ex. energiprestanda direktivet (2002/91/EC), direktivet för att begränsa påverkan på klimatet SAVE (93/76/EEC) samt direktivet för bränslepannor (92/42/EEC). Målsättningen inom

EU är 20 % förnybar energi, 20 % energieffektivisering och 20 % lägre koldioxidutsläpp fram till 2020 (referens 1, 2, 3). Därför bör även trähus stärka sin position och erbjuda mer energieffektiva lösningar. Syftet med detta delprojekt är att utvärdera miljöprestandan för flervåningshus i trä som klarar kraven som har satts upp i den svenska passivhusstandarden (referens 4) med bland annat krav på en maximal effekt för uppvärmning på 10 W/m². Arbetet genomförs i två delar enligt nedan.

1. Erfarenheter från flervåningshus i trä som byggs med passivhustekniken samlas in genom att delta i den pågående byggprocessen i Växjö där fyra flervåningshus i trä ska byggas. Hyresbostäder i Växjö samt HSB är beställare, Martinssons trä är stomleverantör och entreprenör är NCC. Utvecklingsfasen pågår och de sista kravnivåerna vad gäller energiprestandan diskuteras och beslutas snart. En energiberäkningsmodell för byggnaden läggs upp i programmet DEROB-LTH (referens 5). Modellen kommer att fungera som en bas för att beräkna och utvärdera energi- och miljöprestandan för olika lösningar. Expertis från övriga delprojekt deltar i processen för att kritiskt utvärdera tex. fuktbelastningar, installationer, inomhusmiljö och energi.
2. Genom en jämförande studie där angränsande forskning om passivhus går igenom, tillsammans med resultaten från detta specifika projekt, ska generaliserbar kunskap tas fram för att specificera och värdera miljöprestandan för flervåningshus i trä med höga krav på låg energianvändning.

Referenser

- OJ L 1, 4.1.2003 (2003) Directive 2002/91/EC of the European Parliament and of the Council of 16 December 2002 on the energy performance of buildings.
- OJ L 237, 22.9.1993 (1993) Council Directive 93/76/EEC of 13 September 1993 to limit carbon dioxide emissions by improving energy efficiency (SAVE).
- OJ L 167, 22.6.1992 (1992) Council Directive 92/42/EEC of 21 May 1992 on efficiency requirements for new hot-water boilers fired with liquid or gaseous fuels.
- Forum för Energieffektiva byggnader, (2007). Kravspecifikation för passivhus i Sverige – Energieffektiva bostäder version 2007:1
- Energy and Built Design, Dept of Construction and Architecture, Lund (2007) DEROB-LTH for MS-Windows. Computer program. Lund, Sweden.

Sociotekniska studier av lågenergihus

Wiktorina Glad*, Fredrik Karlsson**, Kajsa Ellegård*** och Ewa Wäckelgård****

* Institute for Sustainable Futures, University of Technology Sydney, PO Box 123 Broadway, NSW 2007 Australia, e-post: wikgl@tema.liu.se

** Institutionen för ekonomisk och industriell utveckling, Linköpings universitet, SE-581 83 Linköping, Sverige, e-post: Fredrik.Karlsson@liu.se

*** Institutionen för tema teknik och social förändring, Linköpings universitet, SE-581 83 Linköping, Sverige, e-post: kajel@tema.liu.se

**** Institutionen för teknikvetenskaper, Uppsala universitet, Box 534, SE-751 21 Uppsala, Sverige, e-post: eva.wackelgard@angstrom.uu.se

Abstrakt

Att bygga lågenergihus kan i ett tidsperspektiv till 2050 medverka till en halvering av energianvändningen i bebyggelsen om det genomförs i stor skala vid nybyggnation och renovering. I följande rapport belyser vi några forskningsfrågor som är angelägna att gå vidare med för att minska elberoendet i lågenergihus genom använda energieffektivare apparater och installera bränsle- och elsnåla värmesystem för rumsuppvärmning och varmvattenberedning. Vi framhåller i rapporten att det är viktigt att göra tvärvetenskapliga analyser för att realisera den potential som finns för att minska energianvändningen och visar exempel från en tvärvetenskaplig fallstudie av radhusen i Lindås Park.

Inledning

Lågenergihus har fått en spridning i Sverige under 2000-talets inledning. De radhus som uppfördes enligt passivhusprinciper i Lindås Park Göteborg utgör spridningscentrum för detta. Utfallet av detta byggprojekt har övertygat aktörer inom bostads- och byggföretag att sådana projekt är genomförbara i Sverige och ett antal projekt har efter Lindås Park realiserats i framförallt södra Sverige. Erfarenheterna från Lindås Park är väl dokumenterade och har utgjort en bra grund för kunskapsöverföring och för vidareutveckling av lågenergikoncept för svenskt förhållanden. Radhusen i Lindås Park beskrivs i de flesta sammanhang som ett projekt som i hög grad lyckats nå de uppställda målen och de boende i radhusen är övervägande positiva till sitt boende. Båda dessa faktorer har förmodligen bidragit till att spridningen blivit så pass omfattande.

Sex doktorander inom forskarskolan Program energisystem har använt Lindås Park som fallstudieobjekt för både tekniska och sociala studier och det har resulterat i fem färdiga avhandlingar [Boström 2006], [Glad 2006], [Karlsson 2006], [Persson 2006] och [Werner 2007] samt en under slutförande. Nu planerar forskarskolan för fyra nya doktorandprojekt med syfte att studera tekniska och sociala möjligheter för att nå låg elanvändning i lågenergihus och hur byggande av lågenergihus kan bidra till en halvering av energianvändningen i bebyggelsen i Sverige till 2050. Kunskaper från Lindås Park och efterföljande byggprojekt om lågenergihus är utgångspunkten i de nya projekten och i denna text vill vi beskriva några forskningsfrågor i de nya projekten och ge dem en bakgrund utifrån de tidigare studierna som genomförts i forskarskolan om Lindås Park.

En av grundbultarna i forskarskolans forskning är att anlägga ett sociotekniskt systemperspektiv vilket innebär att vi studerar och analyserar ett system med både social och tekniska komponenter som interagerar. Om man lyckas realisera låg energianvändning i boendet beror dels på de tekniska förutsättningarna utifrån de val av teknik som görs i planerings- och projekteringsfaserna och dels hur hushållen utnyttjar energi i drift och aktiviteter. Detta samspel mellan teknik och aktörer är viktigt att förstå och vi kommer i det följande med några exempel visa att man når en djupare förståelse för problematiken genom att analysera både aktörerna och tekniken.

Lågenergihus i det svenska energisystemet

Ett viktigt skäl för byggande av lågenergihus är dess potential att minska bebyggelsens klimatpåverkan genom att radikalt minska behovet av tillförd energi och därmed minska utsläppen av koldioxid från fossila bränslen som används för elgenerering och värmealstring. I Figur 1 visas en jämförande värdering av koldioxidutsläpp från ett traditionellt hus och ett lågenergihus för tre olika uppvärmningsalternativ: el, fjärrvärme och pellet [Karlsson 2006]. Jämförelsen visar att el eller pellets ger minsta utsläpp av koldioxid förutsatt att elen är producerad i svenska anläggningar. Med europeisk marginal-el, vilket kan tillämpas vid jämförelse mellan enstaka hus, så bidrar pellets med minst koldioxidutsläpp och det blir dessutom ingen skillnad i utsläpp mellan ett traditionellt hus och ett lågenergihus. Mängden pellets blir dock större i det traditionella huset vilket indirekt kan ge ett högre koldioxidutsläpp då den inte kan användas för att ersätta fossilbränslen någon annanstans i energisystemet. Diagrammet visar i princip i vilken utsträckning olika energisystem innehåller fossilbaserad värme- och elproduktion, en kunskap som det är viktigt att inkludera i en systemanalys av hur lågenergihus kan globalt bidra till en minskad användning av fossila bränslen.

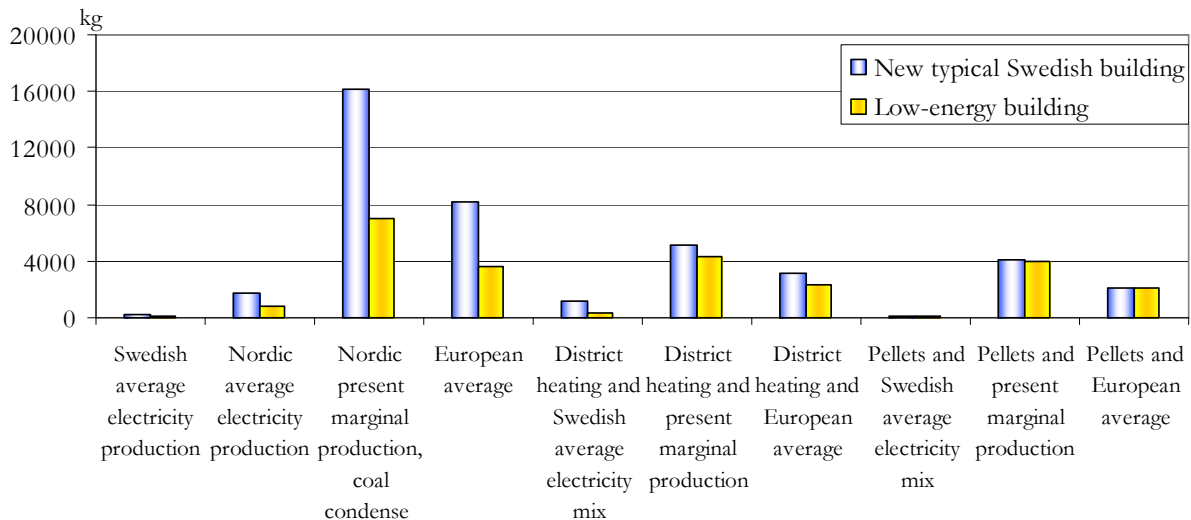

Figur 1. Koldioxidutsläpp från ett lågenergihus (62,5 kWh/m²,år) och ett nytt svenskt standardhus (142 kWh/m²,år) [Karlsson 2006].

Antalet lågenergihus i det totala bostadsbeståndet kommer inom en överskådlig framtid att vara en droppe i havet jämfört med alla pågående och planerade projekt som fortsätter i traditionella spår och framförallt i jämförelse med antalet redan byggda hus. Skall energianvändningen i Sverige minska till hälften av dagens nivå till 2050 så måste detta mål beaktas redan i dagens projekt för renovering av befintlig och uppförande av nya byggnader. Det har i tidigare studier visats den specifika energianvändningen i nya byggnader i slutet på 1970-talet hade uppnåtts i hela bostadsbeståndet trettio år senare [Nässén and Holmberg 2005]. Med en tidskonstant på 30 år kommer bebyggelsen att på 2030-talet att ha samma specifika energianvändning som dagens nybyggda hus. Dessutom tillkommer el som används i hushåll och lokaler, vilket är en post som stadigt ökat under alla år fram till idag. Det är alltså en stor samhällslig utmaning att halverad energianvändning till 2050. Vilka kraftfulla åtgärder kan väljas för att nå halveringsmålet? Givetvis finns det aktörer som förespråkar byggande av lågenergihus som en sådan åtgärd men det finns också företrädare för andra ståndpunkter som menar att dagens energiprestanda är tillräcklig i kombination med att minska andelen köpt energi med effektiva värmepumpar. Ett annat argument som framhålls från aktörer inom energibranschen är att ett för lågt värmebehov i hus byggda inom fjärrvärmenäten hindrar elproduktion i kraftvärmeverk som ur ett europeiskt systemperspektiv kan bidra till sänkning av koldioxidutsläpp i den europeiska elproduktionen genom export av svensk el producerad från biomassa och avfall.

Ett enkelt räkneexempel kan illustrera en uppseglande intressekonflikt mellan byggande av lågenergihus och utökad kraftvärmeproduktion – d.v.s. mellan energianvändning och energitillförsel. Antag, som hypotes att hela

bostads- och lokalbeståndet (exklusive industrilokaler) i Sverige över en natt blir lågenergihus², detta skulle medföra att energibehovet för uppvärmning och tappvarmvatten sjunker från 80 TWh³ till 25 TWh, vilket är en minskning med 70 %. I Sverige försörjs (2006) 80 % av flerbostadshusen, 60 % av lokalytan och 10 % av småhusen med fjärrvärme vilket motsvarade 42 TWh [Svensk Fjärrvärme 2008]. I fjärrvärmeproduktionen härrör 20 TWh värme från kraftvärme [Svensk Fjärrvärme 2008]. För att kunna utnyttja dessa 20 TWh värme från kraftvärmeproduktion i ett lågenergihus-scenario skulle distributionsnäten behöva byggas ut för att kunna ansluta 80 % av den totala bebyggelsen och utan att samtidigt öka produktionen totalt. Detta enkla exempel med makroskopiska nationella värdesiffror återspeglar inte vad som inträffar lokalt i fjärrvärmenät.

Ett liknande räkneexempel kan göras utifrån målet att till 2050 halvera energianvändningen i bebyggelsen. Det innebär att behovet av värme och tappvarmvatten blir 40 TWh (räknat från 2006 års nivå på 80 TWh)⁴. Om kraftvärme prioriteras så kommer 20 TWh värme från kraftvärme att kunna användas inom i stort sett det bestånd av småhus, flerbostadshus och lokaler som idag är anslutna till fjärrvärmenät (och idag använder 42 TWh fjärrvärme). Enligt 2007 års prognos för planerad kraftvärmeproduktion i Sverige så förväntas den byggas ut med 1500 MW el vilket motsvarar en årskapacitet på ungefär 20 TWh värme. I ett sådant scenario så skulle 100 % av bebyggelsen behöva vara ansluten till fjärrvärme 2050.

Exemplen ovan visar att lågenergibebyggelse och kraftvärme kan samexistera i det svenska energisystemet men att det är viktigt att på lokalnivå göra en samtidig planering av bebyggelse och energitillförsel för att optimera systemen utifrån både kostnader, resurser och utsläpp av koldioxid i ett europeiskt perspektiv. Det finns också möjlighet att använda fjärrvärme för process-värme och -kyla vilket inte har övervägts här. I ett av de planerade doktorandprojekten kommer vi att studera hur en samtidig planering av bebyggelse och energisystem kan utformas. Studien består av två delar: en del med fokus på aktörsprocesser och en delstudie med fokus på systemmodeller och optimering av resurser.

Att välja energiteknik för lågenergihus – exempel från en socioteknisk studie av Lindås Park

Radhusen i Lindås Park planerades och byggdes dels som ett byggprojekt med totalentreprenad och dels som ett forskningsprojekt. De båda delarna sammanlänkades via seminarier, så kallade ”forskar- och aktörsseminarier” vilka skulle stödja projekteringen med att utreda olika frågor om val av teknik och gemensamt utarbeta ett kvalitetsdokument. Kraven på de tekniska installationerna var i många fall högre än vad entreprenören och underkonsulterna hade erfarenhet av från andra projekt. Till seminarierna kallades därför experter så att olika frågeställningar kring tekniska lösningar kunde penetreras på djupet. Ett av seminarierna var också tänkt att ta upp frågor om boende och beteende men detta kom aldrig till stånd. [Glad 2006]

I Glads avhandling [Glad 2006] ges ett exempel på teknik som avhandlades på ett seminarium. Valet gällde teknisk lösning för att tillföra extra värme under vintern då fri värme från solen, människorna i husen och spillvärme från apparater inte skulle räcka till för att hålla en önskad inomhustemperatur. Enligt svenska byggregler ska värme återvinnas till 80% i FTX-system men för Lindås-husen ställdes krav på en högre verkningsgrad, 90 %, för att kunna uppfylla målet om 35 kWh/m² i årlig energianvändning. Under projekteringen var det osäkert om det fanns produkter på marknaden med så hög verkningsgrad. SP (Sveriges Provnings- och Forskningsinstitut) fick i uppdrag att testa produkterna i inkomna anbud. Detta förfarande innebar att företagen var tvungna att utveckla sina produkter för att uppfylla de ställda kraven.[Glad 2006] Exemplet visar att samverkan mellan forskarna och entreprenörerna via seminarierna har varit viktigt för att nå uppsatta mål i projektet.

Värmeväxlaren i Lindås-husen utrustades med ett eftervärmningsbatteri på 900 W för avisning av värmeväxlaren kalla dagar och eftervärmning av tilluften kalla dagar då solinstrålning och internt alstrad värme från människor och apparater inte räcker för att uppnå önskad inomhustemperatur. Det rådde oenighet i

² Här används 43 kWh/m²,år vilket är maximal specifik energitillförsel [Forum för energieffektiva byggnader 2007]) beräknad för total uppvärmd area i småhus, flerbostadshus och lokaler [Statistiska Centralbyrån (2007)].

³ Energianvändning i småhus, flerbostadshus och lokaler för 2007 [Statistiska-Centralbyrån 2007].

⁴ Egentligen gäller halveringen från 1995 års nivå.

seminariegruppen om hur stort behovet skulle bli att använda batteriet som extra uppvärmning. Resultaten från mätningar i husen visar i Figur 2 att användningen i praktiken var frekvent under vintern och varierande mellan 400 till 4000 timmar i de olika hushållen under det första året [Karlsson 2006]. Resultaten visar på betydelsen av att hushållen hade tillgång till denna eftervärmningsfunktion för att aktivt kunna påverka inomhusklimatet framförallt under den först tiden innan de lärt sig reglera inomhustemperaturen [Isaksson and Karlsson 2006]. Detta har förmodligen haft stor betydelse för hur hushållen har uppfattat sitt boende så positivt även om det under första året inneburit högre energianvändning än förväntat. Leverantören av värmeväxlare till Lindås Park har senare utvecklat ett vattendrivet förvärmningsbatteri som kan kopplas till fjärrvärme eller annat vattenburet system vilket har använts i lågenergihus byggda efter Lindås Park.

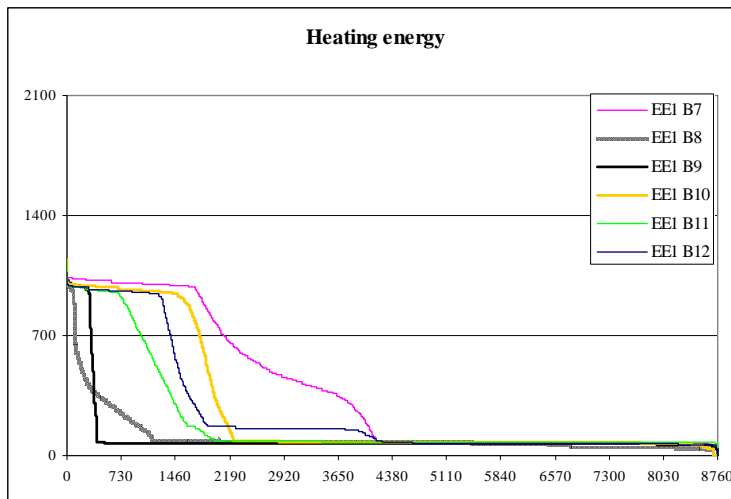

Figur 2. Varaktighetsdiagram för el till värmebatteri (900 W) och fläktar i fem av radhusen. [Karlsson 2006]

Ett andra exempel på hur teknikfrågor processats i seminariegruppen kan illustreras med valet av solvärmesystem i Lindås Park. Den till seminariet inbjudna experten på solvärmeteknik förespråkade en gemensam solvärmeanläggning för hela området. Vinster med ett gemensamt system är mindre värmeförluster från en stor gemensam tank jämfört med lägenhetsvisa små tankar och att kostnaderna för att installera en stor tank blir lägre än för flera små. Nackdelar är större förluster i ledningar från centralen till lägenheterna och kostnader för individuell varmvattenmätning samt skötsel av den gemensamma anläggningen. Utan att göra en djupare utredning av olika tekniska lösningar med solvärme beslutades om individuella lägenhetssystem och att VV-konsulten fick ansvaret att finna ett lämpligt system. I ett tidigt skede antogs att 60 % av tappvarmvattenbehovet skulle täcka av solenergi, i projekteringen var kravet satt till 50 % solenergi (och 50% från elpatron i beredaren). [Glad 2006]

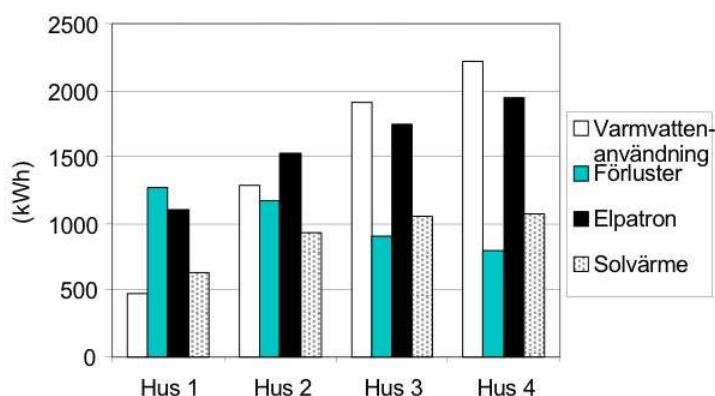

Figur 3. Energidiagram med fördelning på varmvattenanvändning och kompensering av tankförluster samt hur värme tillförs via elpatron och solfångare. [Boström, Glad m. fl. 2003]

Solvärmesystemen i Lindås Park var som nämnts ovan inte föremål för en djupare utredning och ingick inte heller för detaljerad utvärdering i projektet. Detta studerades istället av en doktorand inom forskarskolan i fyra av radhusen [Boström 2006]. Där framkom det att bidrag till uppvärmningen av tappvarmvatten var i medeltal 37 % under första året, vilket är en betydligt lägre andel än projekterat. I diagrammet i Figur 3 visas varmvattenanvändning och tillförsel i de fyra radhusen. Tankförlusterna var stora dels p.g.a för dålig tankisolering och dels för att termostaten i många tankar var inställd på 70°C. Den borde inte vara över 60°C för att uppnå större solvärmeandel. Från intervjuerna med de boende framkom att de saknade kunskap om drift av solvärmesystemet och därför inte uppmärksammat att de skulle kunna ändra termostatens inställning [Boström, Glad m. fl. 2003].

I exemplet med solvärmesystemet så framgår hur tekniklösningen inte blev riktigt utredd och där utnyttjades inte seminariedeltagarnas kunskaper. Tekniken behandlades som färdig och leverantörens garantier om prestanda behövde inte prövas speciellt i projektet. [Glad 2006]

I cirkeldiagrammet i Figur 4 framgår att det i medeltal i hus som inte är gavellägenheter används 20 % av den totala elanvändningen till uppvärmning av tilluften och 23 % till varmvattenberedning som tillsammans utgör 3240 kWh. Ett argument som framhålls från byggsektorns aktörer är att traditionella hus med markvärmepump har lika låg elanvändning som dessa hus. Man ifrågasätter därmed behovet av att införa nyare byggteknik om det inte resulterar i minskad elanvändning.

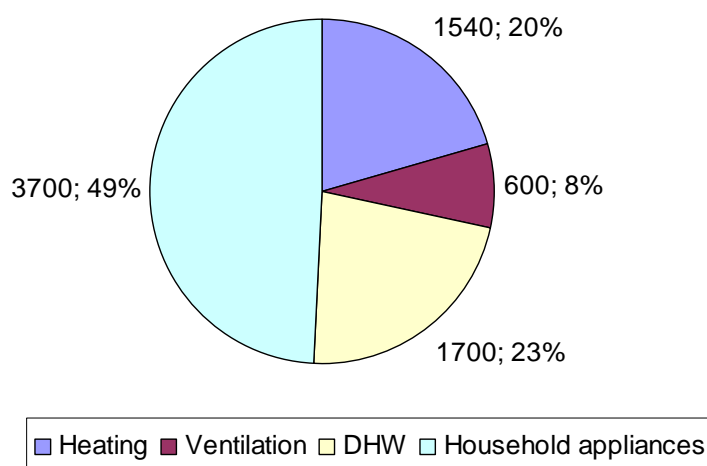

Figur 4. Cirkeldiagram som visar elanvändningens fördelning mellan uppvärmning, drift av ventilationen, varmvattenberedning och hushållsel. Värdena anger medelvärden för antalet kWh och den procentuella andelen i radhus i längorna (ej gavelhus). [Karlsson 2006]

Om vi tänker oss scenariot med 100 % lågenergibebyggelse som använder el till uppvärmning och varmvattenberedning så skulle elanvändningen öka från dagens 21 TWh till 25 TWh vilket också skulle gälla för ett scenario med traditionellt byggda hus med markvärmepump. Konsekvensen är att elanvändningen ökar från dagens nivå och skulle då innebära minskad möjlighet till elexport och även kraftvärmeproduktion eftersom fjärrvärme ersätts med el. I valet av energiteknik för värme till rumsuppvärmning och varmvattenberedning så är det viktig lyfta frågan till en systemnivå så att man kan analysera konsekvenserna av de olika uppvärmningsalternativen i ett europeiskt systemperspektiv som sträcker sig fram till 2050.

För att realisera verkligt låg energianvändning i bebyggelsen så måste man hitta alternativ till el för spetsvärme och beredning av tappvarmvatten i lågenergihus. I ett av doktorandprojekten kommer vi att studera energitekniker med så lågt exergivärde som möjligt. Studien inleds med en kunskapsöversikt för att ta reda på vilka tekniker som är under utveckling och som kan vara kommersiella om tio år. I studien ingår att göra beräkningsmodeller för olika system och simulera och optimera både hushållsegna och områdesgemensamma värmeanläggningar. Systemen kan också utformas för att ta hand om kyl-laster. Syftet är att utvärdera systemens miljöpåverkan och deras kostnadseffektivitet.

Hushållsel i lågenergihus – exempel från en socioteknisk studie av Lindås Park

Hushållsenergin står för hälften av den köpta elenergin i Lindåshuset enligt diagrammet i Figur 4. Tvätt- och diskmaskin kan köras varmvatten som inte värms med el, men i övrigt är hushållets apparater inte konverterbara till någon annan energibärare än el. Det finns möjlighet att reducera andelen köpt el med egenproducerad solceller men investeringskostnaderna i solsystem är ännu höga så det kommer inte att vara ett alternativ inom den närmaste tioårsperioden. Det återstår då att reducera mängden köpt el genom att använda mer energieffektiva apparater och ökad energihushållning. Från en studie från 1995 om energibehov i hushållet så uppskattades hushållselen att vara 2 800 kWh per år om de mest elsnåla hushållsapparaterna vid den tiden användes [Glad 2006]. Hushållen i Lindås Park använde i medeltal 1000 kWh mer än detta enligt de mätningar som genomfördes under första året efter inflyttning vilket delvis beror på att de inte konsekvent har använt energieffektiva apparater eller lågenergilampor utan räknat med att spillvärmes från dessa tillgodogörs i uppvärmning av husen [Boström, Glad m. fl. 2003]. Figur 5 visar ett varaktighetsdiagram över hushållsapparaternas effekt över ett år i sex hushåll.

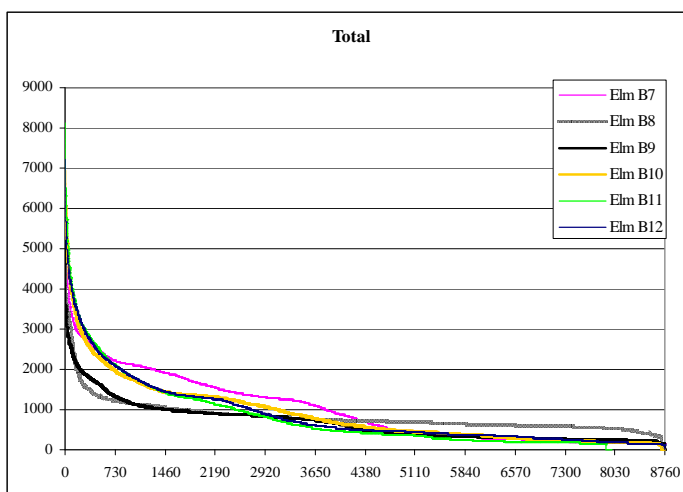

Figur 5. Varaktighetsdiagram över hushållsel i sex radhus i Lindås Park. [Karlsson 2006]

I figur 6 visas tydligt olika effektmönster över året. Hushållet i det vänstra diagrammet använder systematiskt mer hushållsel under vintermånaderna medan hushållet till höger har en mer jämn fördelning över året. Det finns en tydlig korrelation mellan hushållsel och användning av luftvärmebatteriet i de sex hushållen (se Figurerna 4 och 5). De som använder batteriet mindre tid använder mer hushållsel och vice versa.

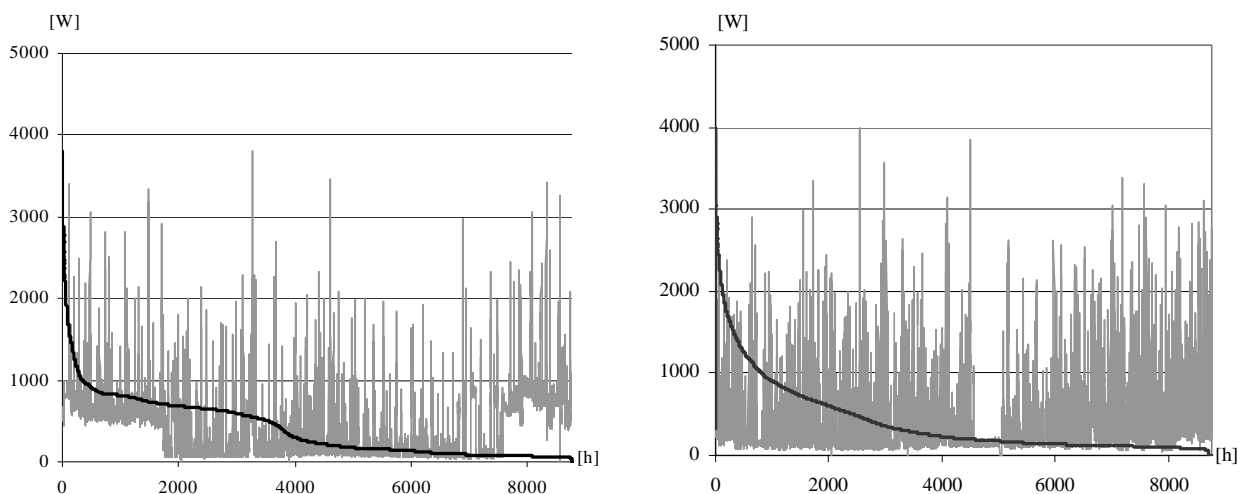

Figur 6. Effektbehovet för hushållsel under ett år i två av hushållen samt varaktighetsdiagram för dessa (vilka också visas i Figur 5). [Karlsson 2006]

I ett av de nya doktorandprojekten kommer vi att knyta an till problematiken om hushållsel. Det är viktigt att nå låg energianvändning genom att hushållen väljer energisnåla apparater. Syftet är att undersöka vilka motiv hushåll har när de väljer utrustning och vilka erfarenheter de som väljer lågenergiutrustning har från användningen av den. Forskningsfrågan är: hur och av vem införskaffas, används och fungerar energisnåla apparater i lågenergihus och vilka är hushållens erfarenheter av apparaterna? Andra besläktade frågor är: hur får produktutvecklare och producentföretag kunskap om hushållens erfarenheter från användning av och önskemål om apparaterna? Vilka inköpskriterier och värderingar har bostadsbolag och deras professionella inköpare när de väljer eller rekommenderar apparater? Vilken roll spelar energieffektivitet för den professionelle inköparen när elräkningen betalas av det enskilda hushållet? När hushållet självt köper apparater, är det då den hushållsmedlem som också kommer att använda apparaten som köper den och vilka valkriterier har de vid köpet? Svaren på frågorna antyder hur utvecklingen av energieffektiva apparater kan komma att se ut. I och med att hushållens livsstil, köp och användning av apparater inverkar på hur mycket av den tekniska potentialen i lågenergihusens sociotekniska energisystem som kan realiseras i faktisk användning behövs ny kunskap om dessa frågor.

Slutsatser

Vi har i rapporten belyst hur en socioteknisk studie kan användas för att analysera innovativa byggprojekt för att sprida kunskap till efterföljare så att förbättringar successivt kan åstadkommas och misstag inte behöver upprepas. Vi har också pekat på några forskningsfrågor som är angelägna att gå vidare med för att åstadkomma en lägre elanvändning i lågenergihus och passivhus än vad som kan uppnås med traditionell bygg- och energiteknik. Vi har också lyft fram vikten av att studera lågenergibebyggelse i ett större systemsammanhang för att systemanpassa energianvändning och tillförsel av energi. Detta är nödvändigt för att i praktiken verkligen nå en halvering av energianvändningen till 2050 så att resurser optimalt med minsta möjliga miljö- och klimatpåverkan.

Referenslista

- Boström, T. "Solution-Chemically Derived Spectrally Selective Solar Absorbers", Avhandling Uppsala University. (2006)
- Boström, T., W. Glad, C. Isaksson, F. Karlsson, M.-L. Persson och A. Werner "Tvärvetenskaplig analys av lågenergihusen i Lindås Park, Göteborg", Arbetsnotat Linköpings universitet, Avdelningen för energisystem - Program Energisystem. (2003)
- Forum för energieffektiva byggnader. "Definition av passivhus", (2007)
- Glad, W. Aktiviteter för passivhus: en innovations omformning i byggprocesser för energisnåla bostadshus. Avhandling. Linköping, Linköpings universitet. (2006)
- Isaksson, C. och F. Karlsson "Indoor climate in low-energy houses -An interdisciplinary investigation." *Building and Environment* **41**, 1678-1690. (2006)
- Karlsson, F. "Multi-dimensional approach used for energy and indoor climate evaluation applied to a low-energy building", Avhandling Linköpings universitet. (2006)
- Nässén, J. och J. Holmberg "Energy efficiency – a forgotten goal in the Swedish building sector?" *Energy Policy* **33** 1037-5. (2005)
- Persson, M.-L. "Windows of Opportunities", Avhandling Uppsala University. (2006)
- Statistiska Centralbyrån. "Energistatistik för småhus, flerbostadshus och lokaler 2006" (2007)
- Svensk Fjärrvärme. "Fjärrvärme- och kraftvärmestatistik 2004", (2008)
- Werner, A. "External Water Condensation and Angular Solar Absorptance", Avhandling Uppsala, Uppsala University. (2007).

Primary energy use of multi-storey wood buildings in a life cycle perspective

Leif Gustavsson and Anna Joelsson. Mid Sweden University, 831 25 Östersund, Sweden

Introduction

The operation phase of a building's life cycle accounts for the largest share of the energy use. In the last decade, efforts have been made to reduce the energy needed for heating, which constitutes a large part of the operational energy for residential buildings. This energy use can be considerably decreased by improved insulation, reduced leakage through the house envelope and by heat recovery of ventilation air. However, these measures result in an increased material use and hence increased energy use in the production and construction phases. As the energy used for operation decreases, the relative importance of the other life cycle phases increase and influence an optimization aiming at minimizing the total life-cycle energy use. Some life-cycle studies of low-energy houses conclude that 40-60% of the total energy use of a low-energy house is consumed in the production phase [Fossdal 1995; Winther and Hestnes 1999]. Hence, for such houses, the choice of material becomes more important for the total energy use. Thormark [2006] has shown that material substitution can reduce the share of energy use in the production phase of these houses by around 15%. Studies from several countries have shown that wood-framed construction requires less energy and emit less CO₂ during the lifecycle, compared to other materials. This is due to the low energy use to manufacture wood products compared to other materials, the storing of carbon in wood products and the opportunity to replace fossil fuels with biofuels from wood byproducts, as well as the avoided process-related CO₂ emission for cement and concrete [Buchanan and Levine 1999; Goverse 2001; Gustavsson, Pingoud et al. 2006]. The life-cycle primary energy use of houses also depends on the energy supply systems, including fuel, end-use heating systems and large-scale heat and power technology. The properties of these systems are significant for the primary energy use, both for the operation phase [Gustavsson and Joelsson 2007; Joelsson and Gustavsson 2007] and for the total life cycle [Zimmermann, Althaus et al. 2005].

Here, we analyse primary energy use for construction and operation of a multi-story wood-framed apartment building and compare it to a functionally identical concrete building as well as to a low-energy apartment building with concrete frames. We also evaluate the effects of energy efficiency measures implemented in the wood-framed building and of different supply systems for heat and electricity.

Methodology

We compared three Swedish apartment buildings. One was built in Växjö in the mid-1990s and has a wood frame. The second was a hypothetical building, functionally equivalent to the Växjö building but constructed with concrete frames. The Växjö wood building was analysed for three cases with different heat demand: 1) the original building, 2) with energy efficient windows with a U-value of 1.0 W/m² *K instead of the original 1.9, 3) with heat recovery of the exhaust air by a plate heat exchanger with temperature efficiency degrees of 0.7. The third building was constructed in 2006 in Karlstad, with a concrete frame and is considered a low-energy building. It was built to enable passive heating but does need some energy supplied for space heating. The ventilation system is a mechanical supply and exhaust systems with plate heat exchangers with a temperature efficiency degree of 0.5. We evaluated the house both with the existing heat exchangers and with mechanical exhaust air without heat recovery. The annual energy demand for space heating and ventilation for the buildings is given in Table 1 for the studied cases.

Table 1. Heated area, number of apartments, and the heat demand in the operation phase of the studied cases

House name	Heated area (m ²)	number of apartments	Final energy demand space heating +ventilation (kWh/m ² , year)
Växjö concrete	1190	16	54
Växjö wood	1190	16	54
Växjö wood, windows	1190	16	42
Växjö wood, heat exchanger	1190	16	31
Växjö wood retrofit (windows + heat exchanger)	1190	16	26
Karlstad	2802	44	35
Karlstad passive (heat exchanger)	2802	44	20

We compared the primary energy needed per square meter of heated area, in both the construction and operation phases. The data for the primary energy use of the production phase are based on studies by Thormark [2006], Persson [2008] and Gustavsson et.al [2006]. All materials used in the buildings were taken into account, and the energy needed to manufacture and transport them. The energy needed for erection of the buildings was not included.

The operation phase was assumed to be 50 years and included space heating, hot water, and electricity for ventilation, household and facility management purposes. Energy use for maintenance during the building life was not included. The hot water and electricity use is not building specific but depend to a large extent on the users. Therefore the annual energy demand for hot water Q_{water} and electricity Q_{el} for each building was set to the following estimations used by the Swedish National Board of Housing, Building and Planning:

$$Q_{\text{water}} = 1800 \text{ kWh} \cdot \text{number of apartments} + 18 \text{ kWh/m}^2 \text{ of heated area}$$

$$Q_{\text{el}} = 2200 \text{ kWh} \cdot \text{number of apartments} + 22 \text{ kWh/m}^2 \text{ of heated area}$$

The operational energy was evaluated for several types of energy supply systems. The end-use heating systems compared were resistance heaters (RH), bedrock heat pump (HP) and district heating (DH). They were combined with heat and electricity supply systems with coal-based steam-turbine technology (CST) and biomass-based integrated gasification combined-cycle technology (BIG/CC). The hot water was assumed to be produced with technology corresponding to the heating system. For the district heating systems, cogeneration plants covered the base-load heat demand. As cogeneration generates both heat and electricity, we used the subtraction method and assumed that the electricity cogenerated in the district heating system replaced electricity produced in condensing power plants based on similar technology and with the same kind of fuel as the corresponding cogeneration plant [Gustavsson and Karlsson 2006]. The energy supply calculations were performed with the software ENSYST [Karlsson 2003], which takes into account the energy chains from the natural resource to the useful energy in the building, including distribution systems.

Results

The decreased operational energy use in the Växjö wood building due to energy efficiency measures is shown in Figure 1. The energy supply was coal-based electric heating. Implementation of a heat exchanger reduced the operational energy more than energy efficient windows.

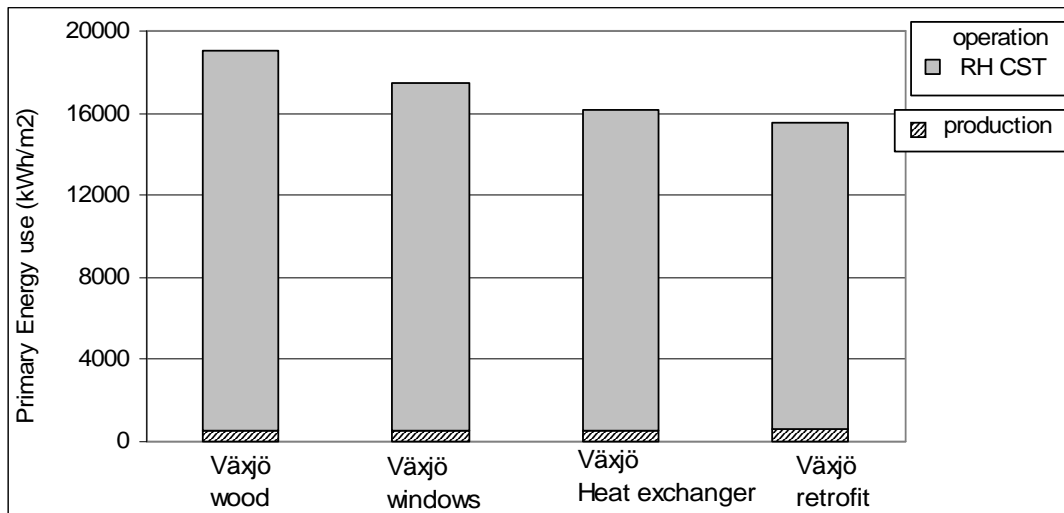

Figure 1. Primary energy use for the operation and production phases of the original Växjö building and the three cases with energy efficiency measures. The energy for operation was coal-based electricity and resistance heating (RH CST).

The Växjö retrofit with installation of both a heat exchanger and energy efficient windows reduced the operational primary energy by 19%. In the context of relative distribution of energy use between life cycle phases it had a minor effect. It increased by 1% the production energy's share of the total energy use. These small effects are due to the building's originally high heat demand and the low energy use for production.

Figure 2 depicts the energy needed for production of five building cases: the concrete and wood alternatives of the Växjö building, the Växjö wood retrofit with energy efficient windows and heat exchanger and the Karlstad building with and without heat exchangers. Both versions of the low-energy building in Karlstad used significantly more energy for production than the buildings in Växjö. The extra energy for the heat exchangers in Karlstad was not significant. The wood-framed version of the Växjö building required less energy for production than the concrete-framed one. When implementing energy efficiency measures in the Växjö wood building the production energy increased, but did not reach the level of the concrete-framed version.

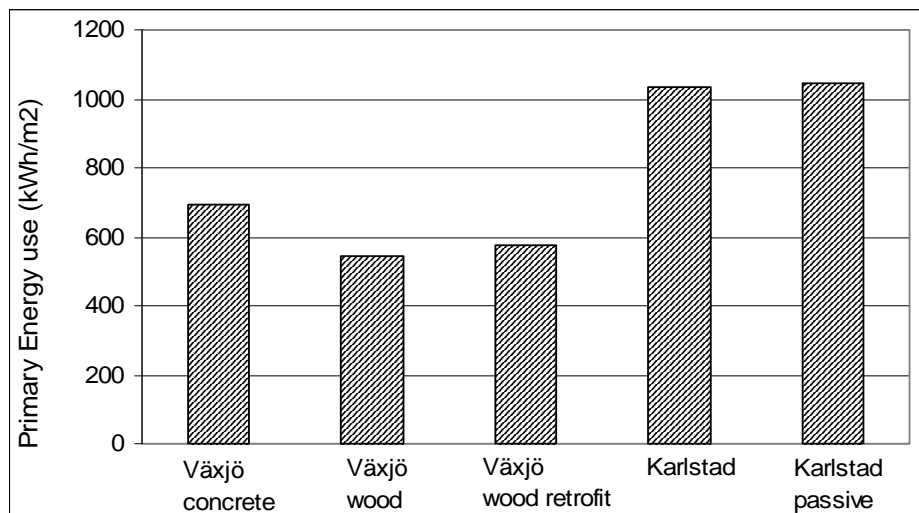

Figure 2. Primary energy use for production of the buildings.

We then included the primary energy for operation in the comparison of the buildings. In Figure 3 the operational energy is supplied by coal-based electricity and electric resistance heating. Despite Karlstad's high energy use for production, the total energy use of the passive version was lower than the original Växjö buildings. This was due to the 17% lower operational energy use. However, the operational energy use was 3% higher in Karlstad passive compared to the Växjö retrofit. When the heat exchanger was excluded from Karlstad the energy use was similar to the one in Växjö original.

The total operational energy included hot water and household electricity, which does not change with building construction. Both hot water and electricity use was greater per heated area in Karlstad, since the building had smaller apartments. When only considering the primary energy for space heating and ventilation it was the lowest in Karlstad passive, 23% lower than Växjö retrofit. When also including the production energy it had 8% lower total primary energy use than Växjö retrofit. In Figure 3 the operational energy is divided into energy for space heating system, the ventilation system, the hot water, and the electricity use for household and building purposes. It can be seen that the ranking of Växjö retrofit and Karlstad passive buildings changed when excluding the hot water and household energy. Also, those two buildings had heat exchangers and hence a higher energy use for operating the ventilation system, which also contributed to the space heating demand.

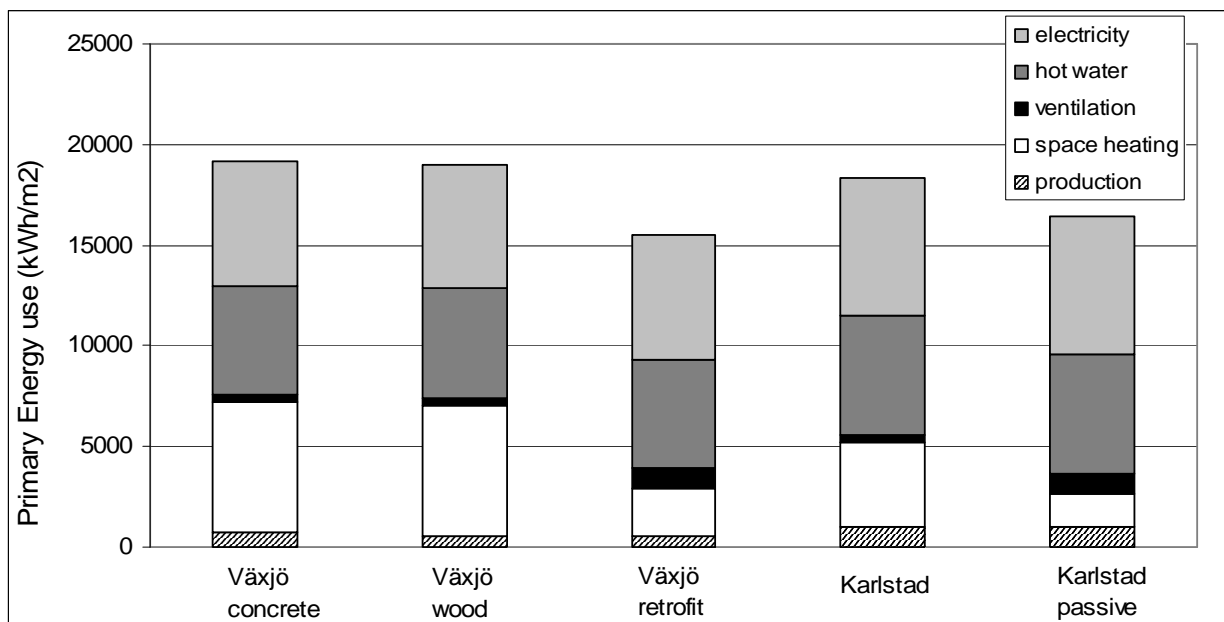

Figure 3. Primary energy use for production and operation of the buildings. The energy for operation was coal-based electricity and resistance heating (RH CST).

Figure 4 illustrates the importance of the energy supply systems for the total primary energy use. Both heat pump systems and district heating are more efficient than resistance heating. When the Växjö wood building used biomass-based district heating (DH BIG/CC) instead of resistance heating with coal based electricity (RH CST) the primary operational energy use was reduced by 55%. This reduction was more than twice as large as when implementing the retrofits. DH BIG/CC was the most efficient energy supply system, and since it is based on biomass it also emits less CO₂ than the coal-based systems.

The production energy constitutes a larger part of the total energy use, as the operational energy decreases. The differences were small, however, and the production energy constituted at most 13% of the total primary energy use in Karlstad when district heating was used for heating and hot water.

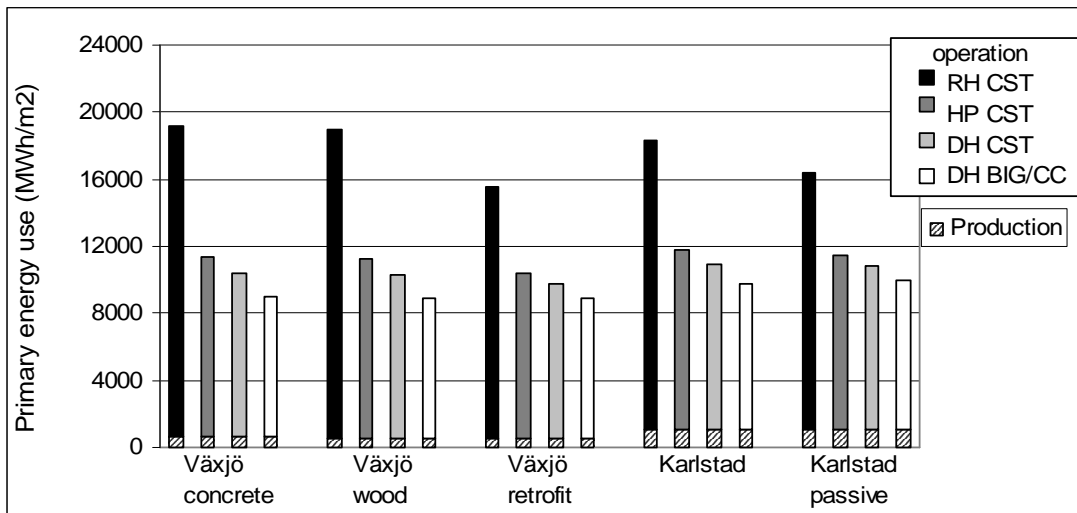

Figure 4. Primary energy use for the production and operation phases, when using different supply systems for operation: resistance heating (RH), heat pump (HP), and district heating (DH), with electricity and heat based on coal (CST) and biomass (BIG/CC).

The production phase constituted a significantly larger part of the total energy use if only primary energy related to space heating and ventilation was included in the operation phase (Fig. 5). In Figure 6 the relative distribution of the production and space heating primary energy is shown, and the importance of the production energy increased at reduced operational energy both due to more energy efficient buildings and more energy efficient supply systems. When Karlstad passive used DH BIG/CC instead of RH CST for heat supply the energy for production energy increased from 30% to 52% of the total primary energy.

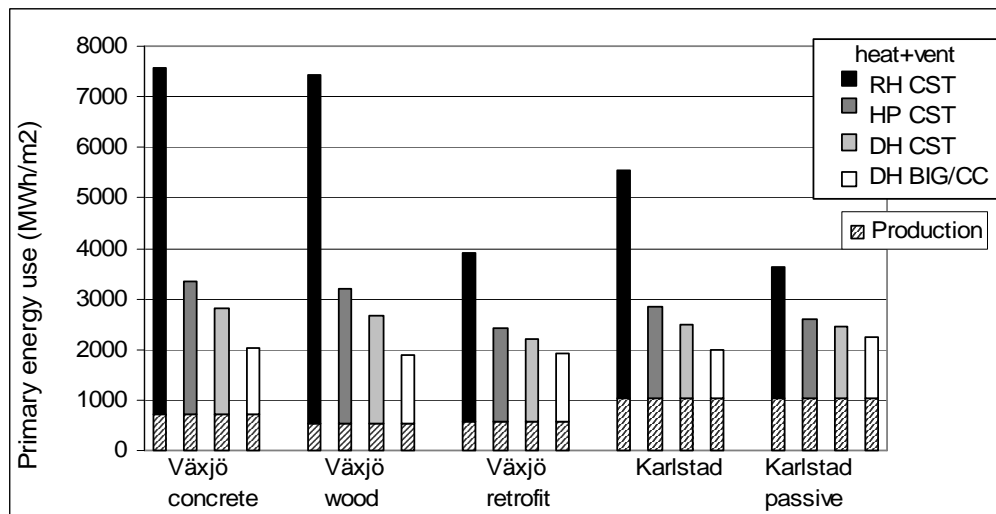

Figure 5. Primary energy use for the production and heating (including ventilation) of the buildings, when using supply systems for heating as in Figure 4.

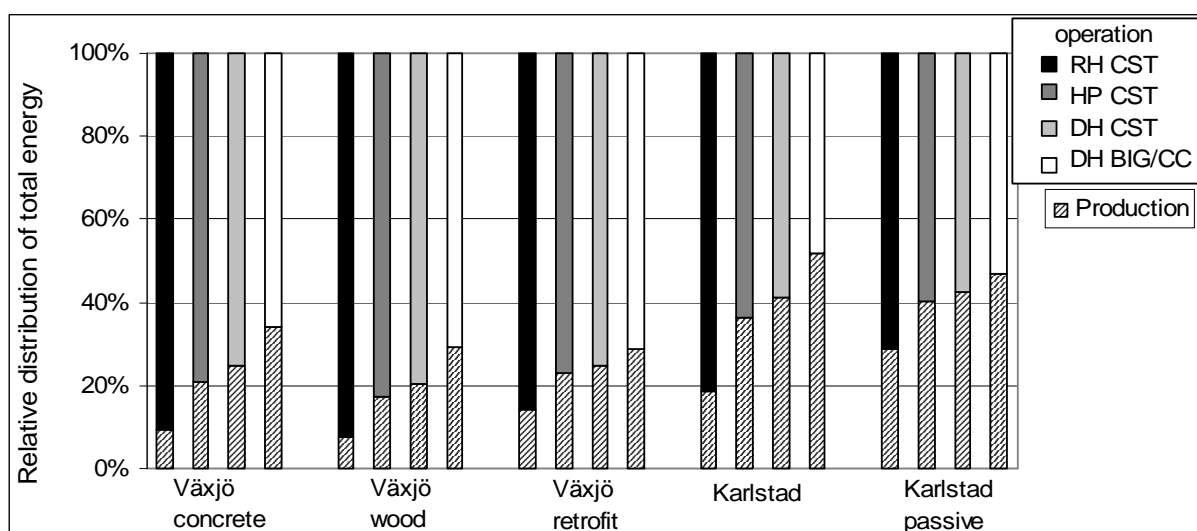

Figure 6. The relative distribution of primary energy use for production and space heating (including ventilation) of the buildings. Supply systems as in Figure 4.

The choice of energy supply system also affected the primary energy ranking of the energy efficiency measures. In Figure 1, the primary energy use in Väjö wood decreased when exchanging the windows, decreased further when installing heat exchangers and was the lowest when implementing both measures (Väjö retrofit). However, in Figure 1 the energy supply was electric heating (RH CST). If the electricity supply instead was biomass-based (BIG/CC), and the heat demand was covered with cogenerated district heating (CHP BIG/CC) the primary energy ranking of the measures was different (Fig.7). The primary energy use for heating was relatively low already without the heat exchangers due to using CHP BIG/CC and hence receiving a high amount of electricity when generating the heat. This creates an efficient system since the electricity can be used to replace electricity that would otherwise have been produced in stand-alone BIG/CC. Therefore the primary energy use for heating decreased less than with less efficient systems. At the same time the electricity use for the ventilation system increased, and was covered by stand-alone BIG/CC (efficiency of 47%), and the increase in primary energy use for the electricity was larger than the decrease for heating.

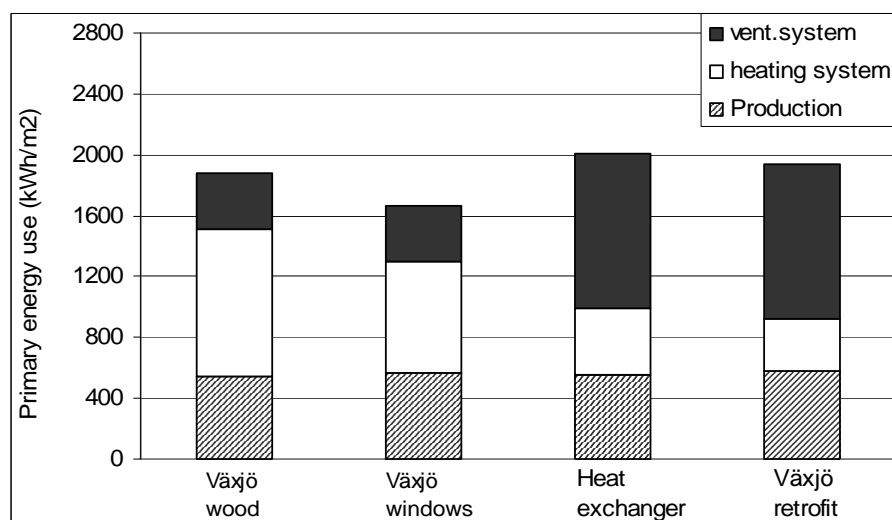

Figure 7. Primary energy use for the production, heating and ventilation of the original Väjö building and the three cases with energy efficiency measures. The electricity and district heating for operation was biomass-based (BIG/CC).

The CO₂ emission from the operation depended heavily on the carbon content of the fuel used in the supply systems. The biomass-based system showed the lowest emission (Fig.8). The resistance heaters had higher emission than the other heating systems, due to the high primary energy use. The two wood versions had

negative emissions in the production phase due to biomass by-products from the wood production chain, which replaced fossil fuels.

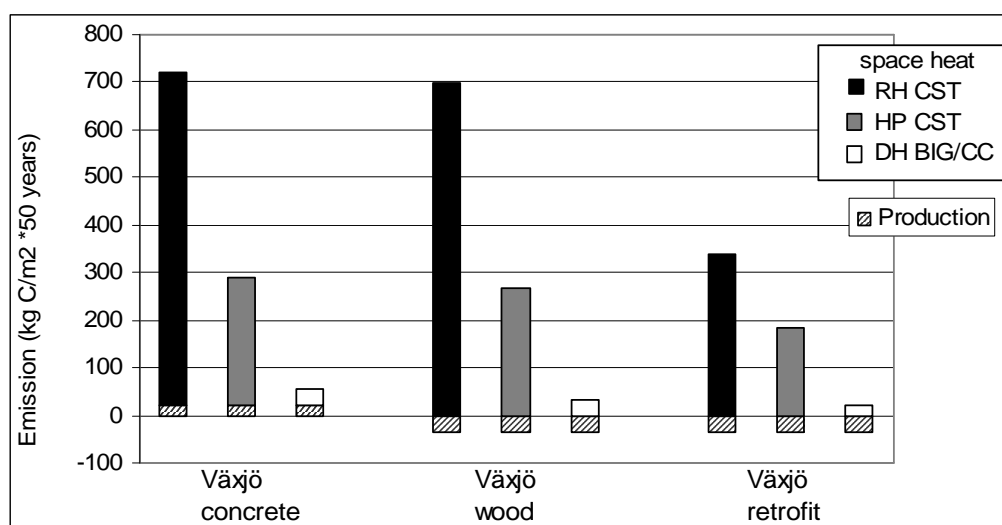

Figure 8. The CO₂ emission from the production and heating of the Växjö buildings. Supply system abbreviations as in Figure 4.

Discussion and conclusions

The primary energy use for production was small compared to the operational energy for all studied buildings. This indicates that even for low-energy buildings, the operational energy is important. However, a large part of the operational energy was used for hot water and household/building electricity. In a discussion on building construction these parts are of less interest, since they do not depend on the building construction itself. When comparing the production energy to the energy use for heating and ventilation we showed that the production energy constituted a significant part of total energy use for the low-energy building during a 50-year time span. Therefore the production phase is essential in order to further reduce the energy use from buildings. The material choice is an important factor for the production energy and the wood-framed building required less energy than the functionally identical concrete-framed. These results indicate that new wood-framed buildings with low operational energy is a more sustainable alternative for the future. The wood building studied here has a relatively high operational energy demand, and we identify a need for energy analyses on multi-storey low energy wood buildings. For a full life cycle analysis the phases not included here, such as demolition and recycling, should be included.

By analysing the primary energy for operational energy we demonstrated the impact of the supply systems, not only for the operational energy but also for the entire life cycle energy use. The relative importance of energy for the building production was also higher when using more energy efficient supply systems for heat and electricity. We therefore conclude that when optimising the energy use of buildings, a life cycle perspective on the energy supply is also necessary. The cogenerated district heating was most efficient, and biomass-based technology could be important for reduced CO₂ emissions. In the Växjö house the energy for operation could be more than halved depending on the choice of energy supply system. This energy reduction was twice as large as that for installing a heat exchanger and energy efficient windows. Both the supply system choice and the energy efficiency measures separately could lead to the Växjö house using less primary energy than the Karlstad house with passive standard. This fact was not seen when just comparing the final heat demands. Hence, the supply system issue should also be considered when planning for new energy-efficient buildings, due to its large impact on life cycle primary energy use, also for low-energy buildings.

References

- Buchanan, A. and Levine B., Wood-based building materials and atmospheric carbon emissions, *Environmental Science & Policy* 2, 427-437 (1999)
- Fossdal, S., Energi- og Miljøregnskap for bygg, The Norwegian Institute of Building Research (1995)
- Goverse, T., Wood innovation in the residential construction sector; opportunities and constraints resources, *Conservation and Recycling* 34, 53-74 (2001)
- Gustavsson, L. and Joelsson A., Energy conservation and conversion of electric heating systems in detached houses, *Energy and Buildings* 39(6), 716-726 (2007)
- Gustavsson, L. and Karlsson Å., CO2 mitigation: On methods and parameters for comparison of fossil-fuel and biofuel systems, *Mitigation and Adaptation Strategies for Global Change* 11, 935-959 (2006)
- Gustavsson, L., Pingoud K. et al., Carbon dioxide balance of wood substitution: comparing concrete- and wood-framed buildings *Mitigation and Adaptation Strategies for Global Change* 11, 667-691 (2006)
- Joelsson, A. and Gustavsson L., District heating and energy conservation in detached houses of differing size and construction, 3rd International Green Energy Conference, Västerås, Sweden (2007)
- Karlsson, Å., ENSYST, Lund, Lund University, (2003)
- Persson, G., Seglet - att bygga ett energisnålt höghus, Karlstad, Karlstads Bostads AB, (2008)
- Thormark, C., Resursanvändning i ett 12-vånings lågenergihus utan värmesystem. Lund, Lund University, Division of construction management, (2006)
- Winther, B. N. and Hestnes, A. G., Solar versus green: The analysis of a Norwegian row house. *Solar energy* 66(6), 387-393 (1999)
- Zimmermann, M., Althaus, H.-J. et al., Benchmarks for sustainable construction. A contribution to develop a standard, *Energy and Buildings* 37, 1145-1157, (2005)

Session 7

Workshop Market and strategy

Erwin Mlecnik

Marketing of Passive Houses: Experiences from the Low Countries 194

Kersten Bonnén

Markedskommunikationsstrategier for lavenergihuse: Skal man tale til forbrugernes hjerte eller hjerne? 204

Eva Ekrem, Bård Haugen, Åslaug Hennissen

Hvordan selge passivhus 211

Trond Haavik, Synnøve Aabrekk, Edward Prendergast

Hvordan markedsføre energieffektive boliger? 213

Marketing of Passive Houses: Experiences from the Low Countries

Civ.eng.-arch. Erwin Mlecnik

OTB Research Institute for Housing, Urban and Mobility Studies, Delft University of Technology, P.O. Box 5030, 2600 GA Delft, The Netherlands

Passiefhuis-Platform (PHP), Gitschotellei 138, 2600 Berchem, Belgium

Abstract

This paper addresses the question ‘How to promote passive houses in an emerging market?’, based on experiences in the low countries.

It describes the change of awareness in the period 2002-2007 and analyses initial market and policy barriers and consequent marketing efforts. Barriers solved and barriers remaining are described from the social, technological, economical and political point of view.

Further a target is set for the (regional) future market. The paper concludes with a long term vision and future implementation path and specifies urgent needs.

The presented examination was performed within the IEE-project ‘Promotion of European Passive Houses’ (PEP), partially supported by the European Commission under the Intelligent Energy Europe Programme.

Change of awareness in the period 2002-2007

Point of departure

In 2002 about 18 companies were involved in the establishment of the Belgian Passive House Platform. In 2004 three passive houses were realized in the Flanders Region. From a Flemish study it appeared that the existing insulation standards lacked efficient control, so quality assurance of passive houses was an issue from the beginning. EPBD regulations were being implemented, a Flemish calculation methodology was available and being implemented into software (freeware). In the Walloon and in the Brussels Region there were no experiences with passive houses. [PHP 2008]

Political change

The change of awareness considering passive houses during the period 2002-2007 has largely been benefiting from change in awareness of related issues.

Awareness of climate change as a political issue

Under the Kyoto protocol Belgium had to decrease emissions by 2008-2012 with 7,5% compared to 1990. According to recent data 1996 already provided a 7,25% increase compared to 1990, so reduction of 15% was the target. Dramatic events like the tsunami in Thailand, hurricane Katrina and reports from IPCC, showing an increase in precipitation in the Low Countries, gave political attention to the changing climate. The Flanders Region installed the Flemish Climate Conference, involving stakeholders from all sectors and ngo’s. Focus was set on reduction of emissions to reduce greenhouse gases, but until now the Climate Conference did not produce any specific results. Popularity of Al Gore further resulted in a Belgian climate ambassador giving presentations all over the country. Also a Belgian federal minister for climate was established. In the Netherlands the rising of the sea level became an important political issue. Many topics have now culminated in a European proposal for a Climate Action Plan.

Creation of energy policies for buildings

The creation of energy policies for buildings is currently driven by the European Building Performance Directive (EPBD).

Since 1st January 2006, as part of the process of demonstrating compliance with required energy performance, assessment of the energy performance of design of new dwellings is mandatory in the Flemish Region (EPB start declaration). For most buildings requiring a building permit, requirements are set for the energy performance and indoor climate (EPB requirements). The reporting of these requirements is undertaken by EPB reporters using required EPB software. The EPB software will serve as a basis for the production of building energy certificates.

The Netherlands is more experienced with energy performance legislation for buildings. The Netherlands already introduced their energy label for buildings in January 2008. Due to the existing certification method, there are few problems issuing an EPBD Energy Certificate for new buildings. The Directive seems to be more difficult to implement for the existing building stock (built before 1997), which is 93% of the total building stock in the Netherlands. [van Ekerschot 2006]

EPBD implementation in the Low Countries has currently limited or no specific obligation for issues of very low energy or sustainable building. The underlying idea is not to oblige but to indicate a way to follow.

Economical change

Awareness of the impact of energy cost

Energy prices in Belgium have increased like in most countries. For social housing the cost of energy will become similar to the rent per month, giving rise to cases of energy poverty. Moreover the rising energy prices have led to increased prices for building materials and houses. The real estate sector in Belgium has been developing in an unsustainable way towards high cost (an increase of almost 11% per year, no matter what energy quality is obtained). For starting single persons the buying of a house has become unaffordable. Also the increase of energy and rental prices leads to decreased buying power of consumers. Most affected are the vulnerable parts of society: young people starting with low wages, older people with small pensions, social housing with limited budget.

Decreasing natural resources

According to Wikipedia current high oil prices are the result of a trend that already started in 1996. According to Hubbert's theory peak oil is reached when we reach the consumption of half of the world wide oil reserve. Natural oil pressure has been decreasing in many oil fields, leading to expenses like injection with water or nitro. Injection can maintain the pressure while the oil field is being further depleted. However, the disadvantage of this method is that oil production decreases a lot after peak oil, leading to increased prices after peak. Therefore decreased oil prices are not to be expected. The amount of price increase is a function of supply and demand and influenced by political factors. Currently estimates show that the price of oil might increase to 150-600 dollar per barrel. In comparison, the highest oil price during the oil crisis in the seventies was 85 dollar. Building materials with high energy intensity (e.g. steel) or based on oil resources (e.g. plastics) follow this trend of price increase. Renewable materials also tend to increase in cost because of their increased use as alternative fuel material. World wide population and wealth increase further puts pressure on the price of all natural resources. It is therefore not to be expected that prices of construction of houses will decrease.

Social change

Media attention for 'houses without heating'

The promotion of passive houses was mainly driven by media attention.

From the first hype on the demonstration of local 'houses without heating', the passive house remained present in press articles and radio and television programmes, thanks to a beneficial economical and political climate. Figure 1 shows the number of press items on passive houses per year in Belgium. Although there was a back-drop after the attention for the first demonstration projects in 2003, the passive house has regained full attention with the introduction of financial benefits and extra dissemination activities in 2007.

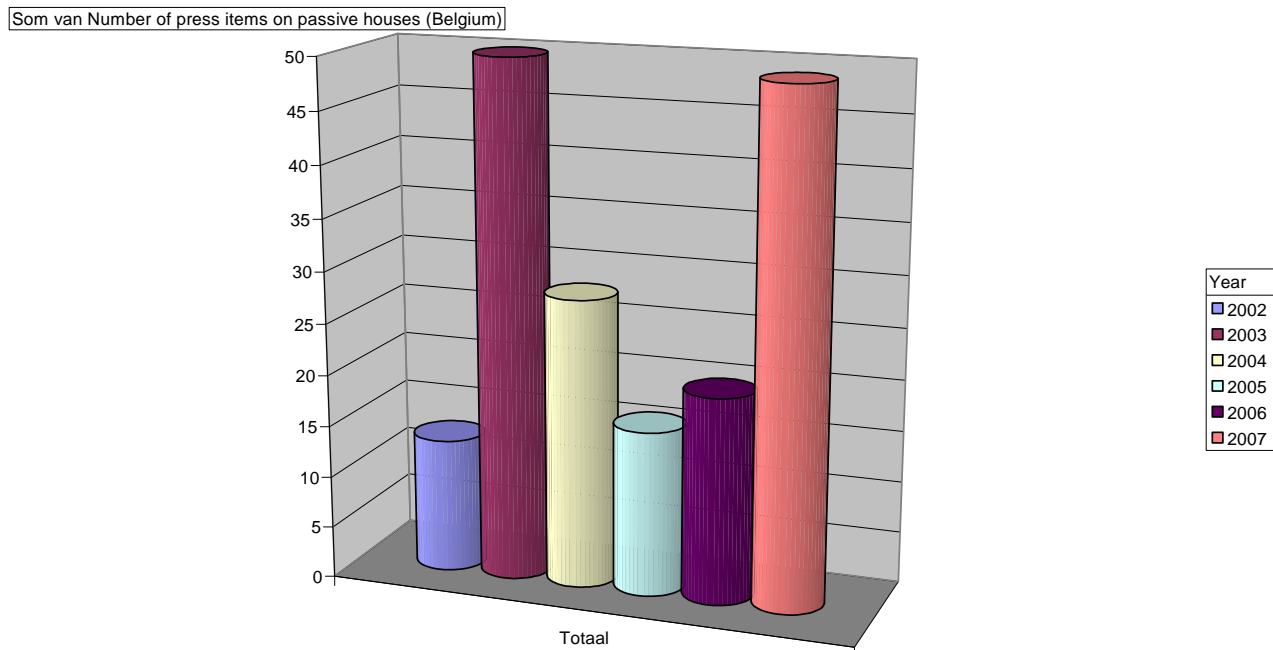

Figure 1: Number of (inventoried Dutch) press items on passive houses per year in Belgium.

A Google search in December 2007 provides 42900 hits for pages from Belgium on the word ‘passiefhuis’, about 50700 hits for pages from Belgium for the word ‘maison passive’, words that did not exist in 2002. The popularity of web sites like www.passiefhuisplatform.be, www.maisonpassive.be and www.passivehouse.be has enormously increased in the period 2004-2007. Nowadays more than 1000 visitors per day are counted. Table 1 shows the number of documents produced during the PEP project. This shows how a financial input from Europe can substantially increase the dissemination of knowledge.

PEP-documents can be downloaded from www.europeanpassivehouses.org :

- Beedel Chris, Phillips Richard, Hodgson Gavin, Mlecnik Erwin, ‘Final Report WP3.4 PassivHaus Certification – met nationaal voorwoord België’ (34 pages, PEP document PHP), 2007
- Boonstra Chiel, Joosten Loes, Strom Isolda, Mlecnik Erwin, Vervoort Sien, de Boer Bart, Elswijk Marcel, Kaan Henk, ‘Oplossingen voor passiefhuizen’, research project report 2006 (54 pages), 2006
- Nieminen Jyri, Jahn Jeni, Airaksinen Miimu, de Boer Bart, Elswijk Marcel, Boonstra Chiel, Joosten Loes, Mlecnik Erwin, Van Loon Stefan, Van den Abeele Stijn, ‘Passiefhuisgids voor gemeenten en stedenbouwkundigen’ (22 pages, PEP document PHP), PHP, Berchem, first edition December 2007
- Nieminen Jyri, Jahn Jeni, Airaksinen Miimu, de Boer Bart, Elswijk Marcel, Boonstra Chiel, Joosten Loes, Mlecnik Erwin, Van Loon Stefan, Van den Abeele Stijn, ‘Passiefhuisgids voor installateurs en energieadviseurs’ (23 pages, PEP document PHP), PHP, Berchem, first edition December 2007
- Nieminen Jyri, Jahn Jeni, Airaksinen Miimu, de Boer Bart, Elswijk Marcel, Boonstra Chiel, Joosten Loes, Mlecnik Erwin, Van den Abeele Stijn, ‘Passiefhuisgids voor projectontwikkelaars’ (21 pages, PEP document PHP), PHP, Berchem, first edition December 2007
- Nieminen Jyri, Jahn Jeni, Airaksinen Miimu, de Boer Bart, Elswijk Marcel, Boonstra Chiel, Joosten Loes, Mlecnik Erwin, Van den Abeele Stijn, ‘Passiefhuisgids voor constructeurs’ (21 pages, PEP document PHP), PHP, Berchem, first edition December 2007
- Mlecnik Erwin, Moens Hermann, Van den Abeele Stijn, Van Loon Stefan, ‘Passiefhuisgids: instrumentarium voor de architect’ (122 pages, PEP document PHP), PHP, Berchem, ISBN 908111823-4, first edition November 2007
- Mlecnik Erwin, ‘National Implementation Belgium Passive House 2004-2007’, EIE/04/030/SO7.39990, 2007
- Mlecnik Erwin, Marrecau Christophe, ‘Passive House Projects in Belgium’, paper scheduled for "The Green Family" issue of the Inderscience Journal of Environmental Technology and Management, 2008.
- Mlecnik Erwin, ‘PassiveHouse 2007: ervaringen met betrekking tot vijf jaar promotie van pasiefhuizen in België’, Proceedings Passiefhuis-symposium 2007, 7 September 2007, Brussels, Belgium (proc. 29-40)

- Mlecnik Erwin, 'Promotion of Passive Houses: from estimating the energy saving potential to the implementation of financial stimuli', 10th international Passive House Conference 2006, 19-20 May 2006 Hanover, Germany (proc. 125-130)
- Mlecnik Erwin, Henz Olivier, 'A la pointe des possibilités actuelles: la construction passive et la rénovation basse énergie', in the proceedings of 'Architecture & Energie en 2050', cerasa Brussels Belgium 19 November 2005
- Mlecnik Erwin, 'Passiefhuizen: energiebesparingspotentieel en klimaatkans voor de bouwsector', Benelux Passive House Symposium 2005, October 21, 2005, Aalst, Belgium (proc. 107-120)
- Mlecnik Erwin, 'Developing an indigenous market for passive solar houses', See the Light 2005, Galway, Ireland
- Mlecnik Erwin, 'Passive House Projects in Belgium', 9e internationale Passivhaustagung April 29-30, 2005, Ludwigshafen, Germany (proc. 447-452)
- Phillips Richard, Hodgson Gavin, Mlecnik Erwin, 'Final Report WP3.8 PassivHaus Technologies Certification – met nationaal voorwoord België' (22 pages, PEP document PHP), 2007
- PHP, 'La Maison Passive', publication nationale 2007 (23 pages, PEP document, PHP), 2007
- PHP, 'PassiveHouse 2007: More comfort less energy': Proceedings of the Passive House symposium 2007, Brussels, Belgium (342 pages), PHP, Berchem, ISBN 908111822-6, 2007.
- PHP, Proceedings of the Passive House Happening 2006, Heusden-Zolder, Belgium (361 pages), PHP, Berchem, ISBN 908111821-8, 2006.
- PHP, 'The Passive House', national publication 2006 (23 pages, PEP document, PHP), 2006
- PHP, 'Het Passiefhuis', national publication 2006 (23 pages, PEP document, PHP), 2006

Table 1: Regional documents produced by or with the contribution of PHP during the PEP project.

Creation of industry networks related to energy efficiency

In 2004 mainly enthusiastic individuals were initiating passive house buildings, either as self built or as small companies. Nowadays, larger companies, building federations and local authorities are driving towards building passive house buildings.

Enough interest was raised to establish a Flemish SME oriented consortium for the promotion of passive houses (PHP, Passiefhuis-Platform vzw). With success PHP took care of networking, contacts with companies, knowledge transfer, guidance of building teams, so that year after year the number of passive houses increased. In the Flanders Region, PHP has grown to become a unique multidisciplinary organization for the promotion of energy conscious building. PEP provided the means to organize seminars for professionals, to contribute to the yearly Passive House Happening with an international PEP workshop, to organize open house days, to be present on regional building fairs and as a speaker on national and international seminars of other organisations. These events were crucial in the motivation of professionals to enter the passive house market or to develop innovative technologies and services.

The marketing strategy and the success story of PHP were soon taken over by other actors: in the Netherlands Stichting Passiefbouwen.nl [SPB 2008] was established, in the Walloon Region Negawatt asbl and Plate-forme Maison Passive asbl, in France La Maison Passive France. A Czech guest student who stayed for a few weeks at PHP found enough inspiration to establish a similar platform in the Czech Republic.

PHP has seen a large increase in the number of its company members (see Figure 2). Company members offer products, services and technologies especially for the realization of passive houses.

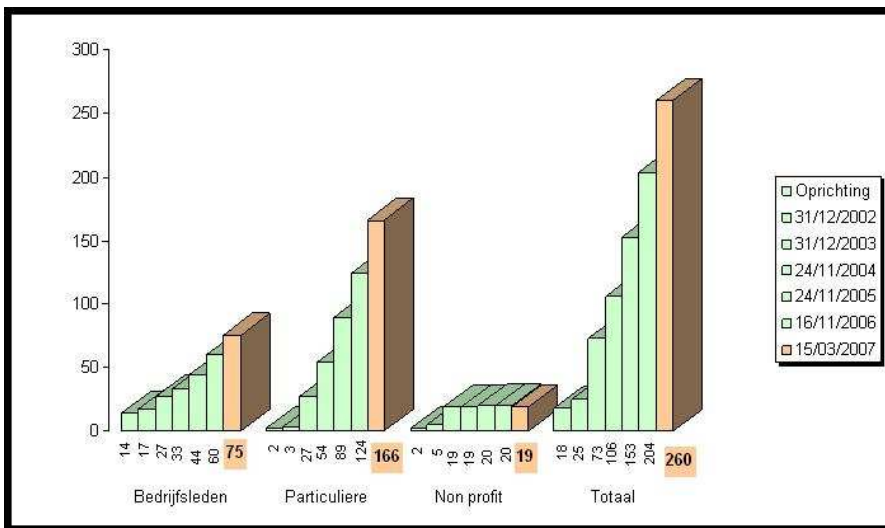

Figure 2: Number of members of PHP per category and evolution in time. From 24/11/2004 to 15/03/2007, 42 companies and 112 exploring individuals have become a member of the Flemish Passive House Platform. Additionally, PMP now lists 11 architects, 13 associations and institutes, 21 service providers, 8 contractors and 11 technology providers as its members active in the French speaking part of Belgium.

EUROPEAN ORGANISATIONS WITH A MISSION TO PROMOTE PASSIVE HOUSES

Belgium:	Passiefhuis-Platform vzw. http://www.passiefhuisplatform.be
Belgium :	Plate-forme Maison Passive asbl. http://www.maisonpassive.be
The Netherlands:	Stichting Passiefhuis Holland. http://www.passiefhuis.nl
The Netherlands:	Stichting Passiefbouwen.nl. http://www.passiefbouwen.nl
France:	La Maison Passive France. http://www.lamaisonpassive.fr
Germany:	Passivhaus Institut Darmstadt. http://www.passiv.de
Germany:	IG Passivhaus Deutschland. http://www.ig-passivhaus.de
Austria:	IG Passivhaus Österreich. http://www.igpassivhaus.at
Switzerland:	IG Passivhaus Schweiz. http://www.igpassivhaus.ch
Poland:	PIBP Polski Instytut Budownictwa Pasywnego. http://www.pibp.pl
Czech Republic:	Centrum pasivního domu. http://www.pasivnydomy.cz
Slovakia:	PassivnyDom Slovakia. http://www.pasivnydom.sk
Europe:	Promotion of European Passive Houses. http://www.europeanpassivehouses.org

Table 1: European organisations with a stated mission to promote passive houses.

Technological change

Transition to sustainable construction

Issues of sustainable and energy conscious construction have been on the agenda of many regional and municipal governments during the previous period. The Flemish Region started experiments with transition management on sustainable building and living, involving stakeholders from all sectors and ngo's. Four working groups were active on closed resource loops (energy and materials), living city cores, innovation and learning. Also in the Walloon Region a focus was set on sustainable construction and innovation with the introduction of the Marshall Plan for the Walloon Region and the programme 'Construire avec l'énergie'. In the Netherlands energy efficiency of buildings has also become a subject of transition management.

Awareness of the existence of trend setting technology

A few trend setters showed the good example and built high quality Flemish passive houses, by now international example projects for the building sector and a show case for the potential of Belgian SME's. In the

Walloon Region, under the auspices of PHP within PEP and the National Lottery, the passive house was first presented in 2005 in the French speaking parts of Belgium on three occasions/ conferences. Some attendants were convinced to build the first passive houses in the Walloon Region. Also in the Netherlands, the Stichting Passiefhuis Holland, provided the first projects built according to the passive house principles. These demonstration projects introduced, mainly imported, novel technologies like triple glazing, insulated frameworks, efficient heat exchangers, ground-air heat exchangers, summer control systems, low power pellet systems, new wall systems, new insulation materials,.. These technologies found interest and foundation, primarily with SME's and in a later stage also with bigger companies. Professionals found their information mainly from visiting regional demonstration projects, from demonstration of these technologies at regional building fairs and from organised events for professionals.

Market penetration: barriers solved, barriers remaining

With the Intelligent Energy Europe project 'Promotion of European Passive Houses' (PEP), the foundations were set on a European level to define the passive house concept as a construction standard, to calculate energy saving potentials and to initiate the regional discussion about (certification of) passive houses. Basic knowledge about passive houses could be transferred from the more advanced German speaking countries towards Belgium. This resulted in the development of national brochures and manuals for architects and other target groups. Information specific to the Belgian building context is now available. The definition proposed in the PEP project is being accepted and is to more or less extent familiar to building practitioners. Nowadays, regional companies can produce adapted products, services and technologies for passive houses. Also, new professions have appeared (e.g. companies specialized in insulation and air tightness services). However, no certification for passive house technologies has yet been introduced, so that energy efficiency values provided can be discussed. There are a greater number of suppliers of building technologies and services suitable for passive houses, but the price of some components like triple glazing is still a market barrier.

Number of passive houses

In the Flanders region 8 habitats have received a voluntary passive house certificate in the period 2002-2007, issued by PHP, as well as one office building and one school.

The PHP database currently contains 151 passive house projects under planning, construction or finished. This covers mostly only Flemish projects, providing that project participants have contacted PHP for consulting. In reality the number of passive houses might be double.

Professional interest is increasing. Until now, 154 copies have been sold of the PHPP software in Benelux edition 2003, compared to 44 in 2004.

However, this is still a low number compared to the number of houses built each year. Also, demonstration projects of renovated buildings are still missing.

Political and financial recognition of passive houses

The current EPB does still not speak of passive houses, since the calculation procedures and the obligatory software were already developed before the introduction of the passive house concept. A good coupling of the passive house concept with the EPB is still to be obtained and requires a substantial research effort. Also, the energy labelling system has not yet been implemented in Belgium and the current labelling system in the Netherlands does not mention the term passive house. Best practice levels have been proposed as equivalent to the passive house requirements and the passive house is mentioned in official reports as a possible level for a future revision of building codes.

From 2006 onwards, the three Regions and the Federal Government Service of Economy, SME, Independent Professions and Energy decided to co-finance the PEP-project, resulting in more efficient information exchange.

On a Belgian federal level the introduction of tax reductions for passive houses was discussed and established in 2007.

Regional grants for passive houses were introduced in Belgium. Currently PHP and PMP are suggested as parties to control the grants and tax reductions, i.e. to control if the submitted projects really reach the passive house standard. However, an open market for certification should be realised.

In the Brussels Region PHP was contacted by government officials in 2005 in the framework of PEP. After discussion ambitions were set high concerning the promotion of sustainable building and passive houses in the Brussels Region, resulting in several regional dissemination initiatives (Fête de l'Environnement, IceChallenge 2007, Passive House Happening 2007,..) and, in 2007, the introduction of grants for passive houses and the appointment of PHP and PMP as a facilitator for the realization of passive houses in the Brussels Region.

The Flemish government developed example buildings like the passive school De Zande in Beernem and the passive office building of the VMM in Leuven.

Recently the Flemish Minister for Housing decided to allocate 500000 EUR for the construction of demonstration social housing in the passive house standard in 2008. Also the passive house concept was introduced into a large Flemish programme to build and renovate schools.

Due to PEP, PHP contributed in the Flemish transition management vision formation on closed energy loops and passive houses. A final outcome, entitled 'Flanders under construction', has recently been handed over to the Flemish Minister President.

Problems arising with the use of the EPB software for the evaluation of passive houses have been reported to the Flemish Energy Agency [Van Loon 2007].

PMP now works in close collaboration with the Walloon Region. Regarding the interest of regional industry, the Walloon Region announced grants for passive houses in 2007.

On the level of Belgian communities and energy providers PEP provided the means to talk with local government officials. The cities of Bilzen and Turnhout and the distribution net manager eandis consequently decided to promote the passive house standard in their regions by providing extra financial means. Some other cities are looking for example projects.

In the Netherlands the passive house concept has been introduced by Stichting Passiefhuis Holland [SPHH 2008] with demonstration projects since 2000, and Stichting Passiefbouwen.nl [SPB 2008] in the framework of PEP. Although many projects are in planning, political incentives to stimulate passive houses are still not developed. Cities and housing associations are looking to create demonstration projects.

It remains to be seen if the Belgian financial initiatives will lead to a substantial breakthrough of the passive house market. Meanwhile, they provide good marketing arguments for companies and they lead to increased interest in the passive house concept (see Figure 1).

Certification based on PHPP calculation is currently performed in Belgium by PHP and PMP on a voluntary basis. The PHPP software serves as a basis. Up till now, the German passive house definition has been used in Belgium, with adjustments in the PHPP software to include regional climate files. Belgian federal tax reduction for passive houses refers to the necessity of demonstrating a certificate for passive houses. However, energy efficiency is a regional matter: the Flemish Region is challenging a different point of view.

In the Netherlands Stichting Passiefbouwen.nl announced an introduction of passive house certification and coupled education initiatives.

Social recognition of passive houses

Awareness of the increased quality related to energy efficiency

Increased comfort is currently the most important selling point to argument possible cost increase of passive houses compared to standard and low energy construction. Comfort issues include improved air quality, stable thermal comfort in summer and in winter, acoustical performance of passive house technologies, (day)lighting quality, user friendly equipment and installations, healthy buildings. Reduction of energy use is often regarded as a beneficial side effect.

However, it should be made possible to reduce the cost of passive houses and passive house technologies, to make them accessible for everybody, especially people prone to energy poverty.

The future market

The potential

The introduction of the passive house concepts offers opportunities of substantial quantity to strive for regional innovation and structured implementation plans.

The biggest potential for the swift implementation of the passive house concept lies currently in the new built construction. In the wake of the construction of example projects, dozens of new passive houses are now under construction, including social housing, office buildings, schools and day care facilities. More than 50% of construction in Belgium is however renovation and finished examples are missing in this sector.

Although Belgium and the Netherlands are catching up on the passive house concept, Germany and Austria are ahead in the development of the passive house standard as a future building standard (see Figure 3).

Consequently, most future oriented energy saving building products and innovations are still coming from these countries.

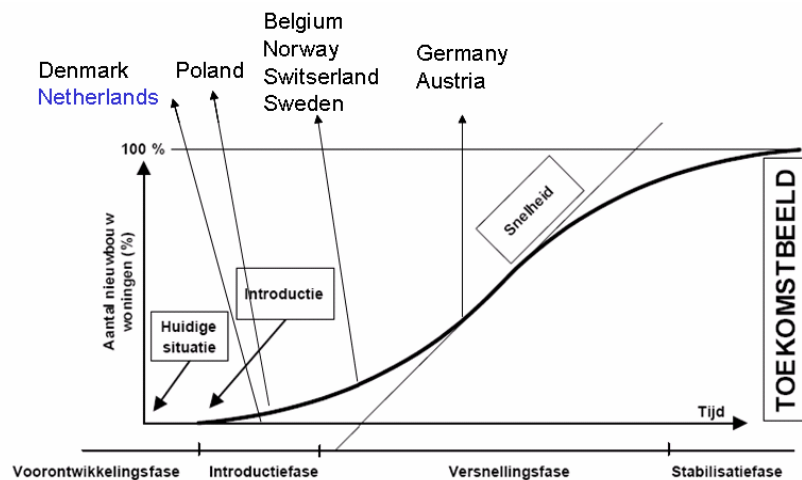

Figure 3: Market situation 2007 [Elswijk 2007]

With the implementation of substantial financial benefits for passive houses in the Brussels Region, it can be expected that, next to new built habitats, mainly new service buildings and renovation of houses will become the biggest (near) future market for passive house technologies and services in Belgium. Also schools will benefit from the passive house experience. In the Netherlands, the market is expected to be driven by social housing companies, although the number of particularly owned houses is increasing.

What kind of information is still required?

It is obvious that the passive house concept is now on the verge of a great leap forward, in the direction of the long-term take-over of the total new built stock. The passive house concept has outgrown its infancy and new challenges are visible: controlling grant initiatives, coupling calculation of passive houses with the EPBD regulation, the development of excellent architecture in the passive house standard, the realization of self sufficient streets and passive quarters, the broad application of passive house technologies in renovations and social habitats. Also for these issues, inspiration can be found in other European countries, where reaching a substantial market share in passive houses has become an essential element in the regional energy and climate policies.

Considering the general public, awareness should be increased on the benefits of living in a passive house (comfort and health). Technical information such as construction details for passive houses without thermal bridges should become available to all architects in 2008. Courses considering passive houses should be implemented for different target groups: architects, installers, contractors, consultants, general public.

Building a first passive house is time, labour and knowledge intense, for some contractors this poses a problem. In general the passive house standard requires a performance oriented quality approach in construction, which is generally missing in the Belgian building sector [Versele 2007]. Belgium does not have any good examples of

energy performance contracting or total building commissioning in relation to energy performance requirements of passive buildings. The operation and energy costs of buildings should get a proper weighting with the real estate financial assessment.

Also, it can be investigated how prefabrication can lower the initial cost of passive houses.

More information is needed about passive house solutions for offices, schools and renovations, as well as for large volume buildings and cost efficient social housing. During the development of the federal research project Low Energy Housing Retrofit it was found that a too tight definition of the passive house standard will become a barrier for wide adoption in the renovation sector. Since the passive house standard is often difficult to reach cost effectively for renovations, adapted definitions and technological solutions and ambitions are required. On the other hand, for offices and schools, specific criteria for cooling energy demand and efficient (artificial and day) lighting are of interest.

The installation and maintenance (health) of ventilation systems can be questionable among potential end-users. User experiences should be demonstrated on a regional level.

The passive house standard is now understood by the Regions as a long term goal to be set as a possible future performance requirement. For the moment the developed EPB software does not include the passive house criterion and does not include specific passive house technologies and criteria.

Which barriers have to be solved now?

Although the government does some careful step in the passive house direction, the most active groups are industry driven (PHP and PMP). These provide the necessary information towards the building actors. However, the goals set in the transition management reference document 'Flanders under construction' require the implementation of an ambitious passive house impulse programme to reach the passive house standard as construction standard in 2015 for all new built construction. Europe tends to strive for 2011 in its Climate Action Plan. This will require swift implementation.

The development of the passive house standard from niche sector towards broad implementation will require the development of targeted education (at universities, high schools, and for different types of professionals) and a good coupling with EPBD development. Very small enterprises and subcontractors are often still unaware of the exact definition and its implications.

Specific sector related innovation in regional companies has to be stimulated since the passive house market is now mainly being filled in with products and systems from abroad.

Barriers that also need be solved on a short term are the definition of the passive house standard for office buildings, schools and renovations, since grants and tax reduction have been introduced.

The example projects will have to show their energy efficiency, cost efficiency and will have to prove the expected comfort. Demonstration projects are urgently needed in the sector of social housing.

Which barriers can be solved later?

In the long term passive houses will need to be more cost and resource efficient and will have to take into account all issues of sustainable development (dismountable and flexible construction, lifelong building, adapted for elderly and handicapped people, local renewable materials, healthy buildings,...). Research is needed to raise the passive house concept outside the energy niche, and to educate, stimulate and obligate the building sector towards a quality oriented performance approach.

PHPP is used by passive house specialists and currently not accepted as an EPB calculation. Both calculations have to be performed. The EPB software will be the basis for the coming energy labelling method, although it has limitations in calculation of passive houses (ground heat exchanger not possible, heat load not calculated precisely, punishment for necessary fictive cooling equipment,...).

Acknowledgements

The PEP-project was partially supported by the European Commission under the IEE Programme EIE/04/030/S07.39990 and co-financed by the Flemish Region, the Brussels Capital Region, the Walloon Region and the FPS Economy, SME's, Independent Professions and Energy, under CONCERE-ENOVER agreement. This publication and presentation was made possible through the support of OTB TU Delft.

References

- [Cobbaert 2005] Cobbaert, Bart, 'Certificatiesysteem voor passiefhuizen', proceedings of the Benelux Passive House Symposium 2005, 21 October, 2005, Aalst, Belgium, PHP, Berchem, 33-52 (2005)
- [Elswijk 2007] Elswijk, Marcel, 'Passive Houses in an international perspective', internal document EIE/04/030/SO7.39990, ECN, Petten (2007).
- [Koschar 2007] Koschar, Elisabeth, 'Implementation of Passive Houses, overview national results Austria', AEE Institute for Sustainable Technologies, Austria (2007).
- [Mlecnik 2006] Mlecnik, Erwin, 'Promotion of Passive Houses: from estimating the energy saving potential to the implementation of financial stimuli', proceedings of the 10th international Passive House Conference 2006, 19-20 May 2006 Hanover, Germany, Passivhaus Institut, Darmstadt, 125-130 (2006).
- [Mlecnik 2007] Mlecnik, Erwin, 'PassiveHouse 2007: experiences with five years of promotion of passive houses in Belgium' (in Dutch), proceedings of the Passive House Symposium 2007, 7 September 2007, Brussels, Belgium, PHP, Berchem, 29-40 (2007).
- [NUID 2007] NUID, 'National implementation Ireland Passive House 2004-2007', internal document EIE/04/030/SO7.39990, NUID, Ireland (2007).
- [PEP 2008] Promotion of European Passive Houses, <http://www.europeanpassivehouses.org>
- [PHP 2008] Passiefhuis-Platform vzw, <http://www.passiefhuisplatform.be>
- [SPB 2008] Stichting Passiefbouwen.nl, <http://www.passiefbouwen.nl>
- [SPHH 2008] Stichting Passiefhuis Holland, <http://www.passiefhuis.nl>
- [SINTEF 2007] SINTEF, 'National Implementation Norway Passive House 2004-2007', internal document EIE/04/030/SO7.39990, SINTEF, Norway (2007).
- [van Ekerschot 2006] van Ekerschot, Frans, Heinemans, Marjolein, 'Implementation of the EPBD in The Netherlands: Status and planning', <http://www.buildingsplatform.eu> (2006).
- [Van Loon 2007] Van Loon, Stefan, Mlecnik, Erwin, 'EPB-calculations of passive houses' (in Dutch), proceedings of the Passive House Symposium 2007, 7 September 2007, Brussels, Belgium, PHP, Berchem, 53-72 (2007).
- [Versele 2007] Versele, Alexis, Van Loon, Stefan, Mlecnik, Erwin, Klein, Ralf, Wauman, Barbara, 'Contracting for Building Teams and Passive House certification in Belgium', IEA ECBCS Annex 47 working document A47-A-M5-B-KAHOSL (2007).

Markedskommunikationsstrategier for lavenergihuse: Skal man tale til forbrugernes hjerte eller hjerne?

Af Kersten Bonnén. Adjunkt, Aalborg Universitet, Institut for Sprog og kultur

Husene sælger ikke sig selv!

Skal man sælge et produkt på markedsvilkår, vil det være nødvendigt at agere på markedsvilkår og gøre sig overvejelser om hvilke segmenter, der er mest attraktive og hvordan man bedst kommunikerer med dem. Dette forhold gør sig også gældende når produktet er lavenergihuse, der kan karakteriseres som et produkt med stort miljøindhold. Produkter med stort miljøindhold er specielle i forhold til, at der iboende i produktet vil være en underliggende stillingtagen til miljøspørgsmålet og dermed inddrage forbrugerens holdning til og viden om miljøspørgsmål. Det vil derfor være relevant at diskutere i hvilket omfang almindeligt anvendte teorier og modeller indenfor markedskommunikation bør og skal anvendes overfor produkter med større miljøhensyn. Situationen vil dog for de fleste producenters vedkommende være den, at man skal agere på markedet på ”markedsvilkår” i direkte konkurrence med andre produkter, der ikke har særlige miljøhensyn. Denne situation er også gældende for producenter af lavenergihuse, hvor producenterne gør sig overvejelser om, hvordan de kommunikerer energibudskabet ud og hvilke argumenter og retoriske strategier der virker bedst for at få flest mulige forbrugere til at vælge lavenergihuse frem for de mindre energivenlige, konventionelle huse.

I artiklen gennemgås således hvordan byggebranchen generelt kommunikerer om energi. De virksomheder som faktisk anvender energiparameteret i markedskommunikationen identificeres og kommunikationen underkastes en nærmere analyse i forhold til de valgte retoriske strategier samt argumenter.

Undersøgelsen

Hvilke former for markedskommunikation anvender danske typehusproducenter når de skal fortælle forbrugerne om deres huses energiforbrug? Det er genstand for en undersøgelse af 65 danske typehusproducenters markedskommunikation i tidsrummet august 07– januar 08. Undersøgelsen omfatter et bredt udvalg af byggefirma samt typehusproducenter og var udvalgt blandt danske typehusproducenter, som er opført virksomhedsdatabaserne ”Kompass” samt ”De gule sider”. Udvalget af firmaer omfatter både typehusproducenter samt byggevirksomheder med erhvervs- og offentligt byggeri samt andels- og almene boliger ud over parcelhusbyggeri til private. Undersøgelsen omfattede for størstepartens vedkommende kommunikationen på virksomhedernes hjemmesider. I første omgang blev der indhentet andet kommunikationsmateriale som brochurer fra virksomhederne. Der var dog næsten sammenfaldene informationer i virksomhedernes brochuremateriale som på de pågældende virksomheders hjemmesider. En undtagelse er dog de virksomheder som har indgået i lavenergi projekter og opført prøvehuse som eks. Stenløse, Fremtidens parcelhuse eller Træbo. Her har nogle af virksomhederne delvist udarbejdet specielt markedsføringsmateriale til disse projekter.

De 65 undersøgte virksomheder kunne stort set opdeles i 3 kategorier i forhold hvordan de inddrog energiparameteret i deres markedskommunikation: Ingen kommunikation overhovedet, lidt kommunikerende, og meget kommunikerende.

Hovedparten, 53 af virksomhederne svarende til 81% tilhørte de ikke-kommunikerende og inddrog slet ikke energiparameteret i deres kommunikation. 11 af virksomheder svarende til 17 % tilhørte de lidt kommunikerende og havde energiparameteret med i deres kommunikation i et vist omfang. 1 virksomhed fremstod som meget kommunikerende og havde udvalgt lavenergiområdet som virksomhedens forretningsområde.

Den lidt kommunikerende gruppe

Den mest interessante gruppe er de lidt kommunikerende. Det er tydeligt, at lavenergi-området ikke er virksomhedernes primære forretningsområde og husene tilbydes ofte som specialhuse, der ikke indgår i det standardiserede produktsortiment. Kommunikationens tilgængelig er ofte ringe – typisk på 3 niveau på

hjemmesiden eller endnu længere nede. Begrebsanvendelsen er præget af usikkerhed. Der er typisk ingen grundlæggende information om hvad begreber faktisk dækker over som energiklasser, lavenergi-vinduer eller U-værdi. Begreber som ”superlavenergi” anvendes ofte til beskrivelse af enkelte bygningsdele typisk vinduer eller isolering uden at forklare hvordan ”super-betegnelsen” ser ud i forhold i forhold til lovgivningsmæssige krav. Samlet set en indforstået begrebsanvendelse, som forudsætter en stor viden hos læseren. Et interessant aspekt er, hvilke retoriske strategier virksomhederne vælger i deres argumentation for lavenerghuse; der var hovedvægt på to temaer: For det første at de faktisk tilbyder lavenergi-produkter¹ og for det andet at det kan betale sig at investere i lavenerghuse². Et tredje argument, at lavenerghuse også er bedre for det globale fremtidige klima valgte kun to virksomheder ganske kort at inddrage.³

Undersøgelse af kommunikationen i lavenerghus-projekter

I undersøgelsen indgår også kommunikationen i 2 projekter, Komforthuse⁴ og Fremtidens Parcelhuse i Køge hvor områder er udvalgt til opførelse af lavenergiboliger med lidt forskellige krav. I begge projekter er der en meget grundig og omfangsrig kommunikation om stort set alle begreber omkring lavenerghuse og her inddrages en række argumenter: Det globale miljø samt at det er en god forretning af investere i et lavenerghus. Dertil kommer argumenter vedrørende indeklima samt materialevalg. Der er god information om hvad f.eks. svanemærket eller passivhus-konceptet betyder samt forskelle mellem energiklasser⁵

Træbo

Et andet lavenergi-projekt er træBo⁶, hvor 5 træhusproducenter⁷ er gået sammen om opførelse af 5 prøvehuse der alle ligger i energiklasserne 1 og 2, hvoraf et desuden er svanemærket, og et andet er CE-mærket. Interessant er det, at kun to af virksomhederne informerer om energiaspektet i husene⁸ hvorimod de øvrige fremhæver andre primære fortrin ved deres produkt: Stil og arkitektur,⁹ indeklima,¹⁰ og Plads/rummelighed.¹¹ Til projektet hører en fælles information, som leveres af Energitjenesten, hvor der dog udelukkende fokuseres på økonomiske fordele ved lavenerghuse. Argumenter vedrørende det globale klima vælges fra.

Norske Svanemærket huse

I Norge har der været iværksat en kampagne om Svanemærkede huse, og i undersøgelsen indgår kommunikationsmateriale fra 3 projekter: Skanska, Husbanken samt Mesterhuse. Der er valgt meget forskellige udformninger af materialet; Skanska har valgt en billedlig fremstilling mens Mesterhuse har en meget teknisk og informativ kommunikationsstrategi. Begge diskuteres senere.

Hovedresultater

Undersøgelsens nok mest forbavsende resultat er, at der er meget lang imellem de firmaer der faktisk informerer forbrugerne om, at lavenerghuse eksisterer og kan leveres hvis ønsket. Kun et fåtal af firmaerne nævner overhovedet energispørgsmålet i deres forbrugerrettede kommunikation og tilhører gruppen ”de ikke-kommunikerede” i forhold til energispørgsmålet. En mindre del har energispørgsmålet med i deres kommunikation, men i en meget usikker og mest forvirrende form.

Undersøgelsens hovedresultater er:

¹ Hellevik-Huse: ”Lavenergi produkter af højeste standard”. CasaBo: ”..den næsten utopiske energiklasse 1, hvor energiforbruget reduceres med op til 75%”. Tømregården: ”...leveres i energiklasse 1”

² ATB-huse: ”Man kan spare rigtigt mange penge til opvarmning i et lavenergi træhus eller bo i et større hus med samme bolig udgift”

³ Danhaus fremhæver, at lavenergi er godt for klimaet. Hornsherredhus: ”i forhold til energiforbrug er boligen fremtidssikret”.

⁴ Et samarbejde mellem Zeta invest, Middelfart Sparekasse og Isover. Beliggende ved Skibet, Vejle

⁵ Fremtidens Parcelhuse, Køge. Informationsmateriale til projektet.

⁶ Træbo, Hasselvangen, Solbjerg v/Århus

⁷ Virksomhederne er: DanHaus, Hellevik Hus, Hornsherredhus, Lønneberg Huse og Trelleborg huse

⁸ Hornsherredhus og Trelleborg hus.

⁹ Danhaus.

¹⁰ Hellevik Hus

¹¹ Lønneberg Huse

- Typehus-virksomhederne med private kunder som målgruppe kommunikerer mere om energi end virksomheder med erhvervs-kunder.
- Virksomheder med typehuse af træ var i overtal i den kommunikerende gruppe i forhold til husproducenter af tegl eller andre materialer.
- Bygge-virksomheder med erhvervs-, offentligt byggeri samt andels- og almene boliger lå alle i den ikke-kommunikerende kategori.
- Bygge-virksomheder specialiseret i renovation lå også alle i den ikke-kommunikerende kategori
- Kun en virksomhed har en omfangsrig og informativ kommunikation om lavenergiboliger
- Lavenergi –projekter har ligeledes en omfangsrig og informativ kommunikation om lavenergiboliger, som en tredjepart – typisk kommunen eller Energitjenesten står for.
- En stor del af de virksomheder som deltog i lavenergi-projekterne med et prøvehus tilhørte den ikke-kommunikerende gruppe, selv om de faktisk havde et salgbart lavenergi-hus

Lavenergi-huses markedskommunikation set i forhold til klassiske markedskommunikationsmodeller

Selv om markedsføringen af produkter med større miljøindhold vil indeholde en ekstra dimension vil anvendelse af kommunikationsmodeller man normalt arbejder med indenfor markedskommunikation, være relevant. I denne sammenhæng vil det derfor være interessant at se på husproducenternes markedsføring vurderet ud fra klassiske markedskommunikationsmodeller. Hyppigt anvendte modeller skelner dels mellem produkter med høj og lav involveringsgrad og dels mellem den følelsesmæssige hhv. videnskabelige involvering. En meget anvendt model FCB-grid, [Vaughn 86] anvender begge dimensioner og indordner produkter i 4 kategorier: Høj/lav involveringsgrad samt en affektiv /informativ kommunikationsstrategi (den såkaldte think/feel-strategi). Modellen inddeler således købsprocessen i 4 kvadranter, der hver har en optimal kommunikationsstrategi:

- 1) **Den informative**, der omfatter købsprocesser med høj involveringsgrad og høj grad af overvejelse (think-begrebet). Her vil den bedste strategi være den såkaldte ”learn-feel-do”model, hvor forbrugeren først informerer sig, efterfølgende danner sin holdning til produktet og til sidst foretager købshandlingen.
- 2) **Den affektive**, der ligeledes omfatter købsprocesser med høj involveringsgrad, men hvor holdningen til produktet spiller en større rolle end faktuelle informationer. Her vil den bedste strategi være den såkaldte ”Feel-learn-do”model, hvor forbrugeren først danner en holdning til produktet, efterfølgende indhenter informationer om produktet før købshandlingen foretages.
- 3) **Den habituelle**, der omfatter købsprocesser med lav involveringsgrad og høj grad af overvejelse. Her vil den bedste strategi være den såkaldte ”do-learn-feel”model, hvor forbrugeren først køber produktet efterfølgende informerer sig om produktets egenskaber og efterfølgende danner sin holdning til produktet. Det vil fortrinsvis være dagligdags produkter, der ikke indebærer en stor økonomisk risiko, der er placeret i denne kvadrant.
- 4) **Den tilfredsstillende**, der omfatter købsprocesser med lav involveringsgrad og hvor holdningen til produktet spiller den væsentligste rolle. Her vil ”do-feel-learn” modellen være den bedste strategi, hvor forbrugeren først køber produktet, efterfølgende danner sin holdning til produktet og til sidst informerer sig om produktets egenskaber. Også her er det fortrinsvis dagligdags produkter, der ikke indebærer en stor økonomisk risiko, hvor det er sansmæssige egenskaber som eks. smag, duft, udseende ved produktet, der er afgørende.

I modellen indplaceres produkterne i forhold til hvor meget forbrugeren involverer sig i købet, og der er foretaget en række empiriske undersøgelser, der har placeret produkter i de forskellige kvadranter. Der kan dog ikke herske tvivl om, at et huskøb indebærer stor økonomisk risiko, og det alene vil være et argument for at definere produktet som et høj-involvering-produkt. Et kompleks høj-involveringsprodukt med høj økonomisk risiko vil normalt indplaceres som et produkt der kræver en stor informationsindhentning før købsbeslutningen og skulle placeres i den informative kvadrat i modellen. Dog er et huskøb en så kompliceret købsproces, der dels kan involvere flere beslutningstagere, men også være opdelt i forskellige faser, at både holdninger til udseende, farver, materialer etc., samt faktuelle informationer vil være afgørende for købsbeslutningen. Komplekse forbrugerbeslutninger som f. eks en bil [Hansen 87] kan således involvere 40-50 forskellige alternative mærker og modeller og indeholde et meget stort antal valgkriterier. Der vil således være både

beslutninger, der vil kunne placeres indenfor den kognitive del og hvor den informative strategi ville være optimal. Men også beslutninger, der afgøres af følelser, personlighed og sanseeffekter hvor den affektive kommunikationsstrategi vil være optimal.

Bestemmelse af den informative og affektive strategi

Hvordan afgøres om en valgt strategi tilhører enten den informative eller affektive? I forhold til kommunikationen omkring lavenergihuse er følgende måleparametre valgt til den bestemte den informative strategi: Forbrugeroplysninger med faktuelle oplysninger om produktet - i dette tilfælde:

- Præcise oplysninger om husenes faktiske energiforbrug
- Oplysninger om hvordan det lave energiforbrug fremkommer: isolering, vinduer, anvendelse af teknikker til energibesparelse samt alternative energiudnyttelse som passiv/aktiv solvarme, ventilationssystemer, eller varmepumpe
- Oplysninger om pris for de energibesparende tiltag i forhold til den faktiske besparelse på husenes energiforbrug.
- Anvendelse af specifikke fagtermer som U-værdier, isoleringstyper/tykkelser, vinduestyper m.v.

Måleparametre der valgt til bestemmelse af den affektive strategi er: Skabe præferencer gennem opbygning af en positiv holdning til produktet fremkaldt af positivt ladede følelser – i dette tilfælde:

- Kommunikation, der har til formål at fremkalde en positiv holdning til lavenergihuse gennem anvendelse af billeder, ord eller tekststykker, der må formodes at et flertal af forbrugerne vil opfatte som positivt ladede.
- Ved den første eksponering anvendes billeder, ord eller tekststykker, der udelukkende har til formål at skabe en forbindelse mellem positive oplevelser eller erindringsbilleder hos forbrugerne og produktet lavenergihuse uden at bringe faktuelle informationer om produktet. Konkrete produktinformationer er fraværende.
- Først når den affektive strategi har medført succesfuldt positiv indtryk hos forbrugeren vil der efterfølgende formidles mere konkrete produktinformationer.

Spørgsmålet er nu hvilken strategi de kommunikerende virksomheder faktisk har valgt. Her tegner der sig et ret tvetydigt billede: I halvdelen af at eksemplerne har producenterne valgt at tage udgangspunkt i en meget informativ strategi¹², med meget reducerede affektive indslag. De affektive dele udgøres i Mesterhus's materiale af forsidebilledet hvor en morfar kigger ud af ruden med sit barnebarn, mens man efterfølgende går over til en meget teknisk og udførlig dokumentation for husenes energieffektivitet. Hos Trelleborg begrænser den affektive del sig til pæne modelbilleder af husene samt igen en meget informativ og udførlig teknisk information. TræBo inddrager en del forskellige skovbilleder dels med legende børn og dels med huse, mens indledningsteksten indeholder tungvejende økonomiske argumenter for at vælge et lavenergihus.

Den anden halvdel har valgt en langt mere affektiv strategi og udgøres af Komforthusenes to brochurer samt de to norske annoncer for Svanemærkede huse, som Skanska og Husbanken står for. Komforthuse har i deres materialet lagt vægt på livet i husene. En lang række billeder viser forskellige familiesituationer der foregår i huset: Far hhv. mor med legende børn, far i køkkenet, mor som arbejder samt billeder af huset i skønne omgivelser. Indimellem kommer der grundige og forståelige informationer om hvad et passivhus er, men uden tekniske detaljer.

Skanska og Husbanken vælger en lidt tilsvarende strategi, hvor billeder er i centrum; i Skanskas annonce er hovedbilledet et flot hus der besøges af et meget sødt svanepar, mens Husbanken har valgt et menneskemotiv: En smuk men ikke helt ung kvinde sidder og arbejder foran vinduet med smukke svaner udenfor. Temaet kunne passende beskrives som mennesket, der bliver et med naturen med et svanemærket hus. Her er tekniske informationer næsten helt udeladt.

¹² Mesterhus, Trelleborg og indledningsteksten til TræBo-projektet

Vurdering af de to strategityper i forhold til en segmentbetragtning

For at nå frem til en vurderingsmåde i forhold til hvilken strategitype der kan betragtes som mere eller mindre effektiv til forhold til lavenergihuse, vil det være relevant at inddrage segmentbegrebet – og her anvende et holdningsmæssigt segmenteringsparameter. En interessant undersøgelse af danske forbrugernes holdning til økologiske fødevarer, samt produkter med stort miljøindhold samt holdninger til økologi [Beckmann 01] inddeler befolkningen i 5 segmenter i forhold til 3 aspekter: Miljøviden, miljøholdninger, miljøadfærd. De 5 segmenter er fremkommet gennem telefoninterview med 1500 personer.

Tabel 1: Danske forbrugeres forhold til økologiske fødevarer samt miljøadfærd og miljøholdninger

De uinteresserede grønne	De skeptiske grønne	De teoretiske grønne	De praktiske grønne	De stedsegrønne
Andel af befolkningen: 23%	Andel af befolkningen: 19%	Andel af befolkningen: 20%	Andel af befolkningen: 22%	Andel af befolkningen: 16%
Beskrivelse af segmentet: Ringeste viden om miljø Lavere uddannelse. Stor overrepræsentation af kvinder samt husstande, yngre samt husstande med 4 børn. Færre kender Ø-mærket Opprioriterer personlige værdier – nedprioriterer de samfundsmæssige	Beskrivelse af segmentet: Ikke særlig miljømæssig holdning og adfærd Middelstore viden om miljø, men bruger den ikke i adfærden. Oftest enlige med lavere uddannelse og indtægt. To værdier præger gruppen: "Autoritet" og "sjov og glæde i livet"	Beskrivelse af segmentet: Minder om de skeptiske grønne, viser dog lidt højere miljøhensyn i adfærden. Stor viden om miljø, som dog ikke helt kommer til udtryk i adfærden. Overvægt af 25-54år Højere uddannelse 9 ud af 10 kender Ø-mærket To værdier præger gruppen: "Velfærd" og "selvrealisering"	Beskrivelse af segmentet: Har ikke den største viden om miljø, men et højt niveau for miljøholdninger og adfærd. Overvægt blandt de 35-64 årige. Færre kender Ø-mærket end hos de teoretiske grønne Sundhed har højeste prioritet mens miljøhensyn næsthøjest	Beskrivelse af segmentet: Scorer højest på miljøhandlinger og adfærd. Overvægt blandt de 35-64 årige samt kvinder. Kort - mellem uddannelse. Højeste gennemsnitindtægt. Flest husstande med børn, færrest enlige Mest vidende om miljømærker. Nedprioriterer personlige værdier – opprioriterer sociale værdier.
Kilde: Bechmann m.fl. 2001				

Undersøgelsen viser desuden indikationer på en aftagen viden om miljø hos befolkningen – sammenlignet med en tilsvarende undersøgelse fra 1991 hvor forbrugerne bliver bedt om at tage stilling til hvilke skadelige virkninger har stoffer der findes i f.eks. rengøringsmidler. I undersøgelsen fra 2001 er der færre, der kan svare rigtigt på disse spørgsmål. Der er altså en reduktion af befolkningens miljøviden, som underbygger formodningen om, at interessen for miljøviden er dalende. Der er en tendens til mindre bekymring for forurening og et mere pragmatisk syn på miljøproblemerne. Forklaringen kan være at staten de sidste 15 år frem til 2001 har allokeret flere ressourcer til at begrænse udledninger og beskytte miljøet, som har ført til at befolkningen oplever der bliver gjort noget, og det kan muligvis forklare hvorfor egenindsatsen er faldende. Samlet konklusionen af undersøgelsen er at der gennem 90'erne er sket en markant ændring i forhold til miljøviden og adfærd. Den generelle økologiske viden er faldet betydeligt, ligesom miljøansvar og handlinger i dag udføres i mindre grad end begyndelsen af 90'erne.

Informativ eller affektiv strategi i forhold til segmenter

Segmentmodellen i forhold til økologi, miljøadfærd og miljøholdninger viser en stor spredning i forhold til forbrugernes miljøviden og adfærd. Den afgjort største viden og mest miljømæssige adfærd findes hos de "Stedsegrønne" og delvis hos de "Praktiske grønne", og man kan formode at den kommunikation, som de kommunikerende virksomheder har, vil tiltale disse to segmenter. Eller anderledes formuleret: Uden en forudgående viden vil disse virksomheders kommunikation ikke være forståelig. De fleste af de kommunikerende virksomheder havde til tider en meget indforstået anvendelse af fagbegreber, som forudsatte en stor forviden hos målgruppen. Trelleborg huse samt Mesterhuse havde dog en mere omfattende information i

deres kommunikation, som dels anvende fagbegreber, men som også forklarede dem så de blev forståelige for forbrugere uden tekniske forudsætninger. En informativ strategi kræver, at der er en indsigt og interesse for området hos målgruppen og disse to segment som fortrinsvis har det sammen med miljøadfærden udgør 38% af forbrugerne.

Til gengæld kunne man formode, at den affektive strategi kunne være mere målrettet mod ”de teoretiske grønne”, som har en stor viden om miljø, men hvor adfærden halter bagefter, og som udgør 20% af forbrugerne. Denne gruppe har en stor viden i forvejen, men der er barrierer i forhold til at handle miljørigtigt. En mulig strategi hvordan denne gruppe kan bringes til at handle mere miljørigtigt og f. eks vælge lavenergirigtige huse kunne være, at bringe kommunikationen i overensstemmelse med segmentets foretrukne værdier, som handler om velfærd og selvrealisering. I praksis vil affektiv kommunikation kunne vise segmentet hvad et hus kan gøre for at opfylde disse værdier. Ser man Komforthusenes brochurer samt reklamerne fra Skanska samt Husbanken har de valgte motiver en tydelig funktion i forhold til især at formidle værdien ”selvrealisering” (Komfort samt Husbanken), mens værdien ”velfærd” mest bliver tydelig i Skanskas reklame, hvor vægten er lagt på huset udtryk, samt indplacering i velhavende omgivelser (natur, vand, både). Spørgsmålet er hvorvidt den affektive strategi vil være virksom overfor de resterende segmenter, ”de uinteresserede grønne” og ”de skeptiske grønne”. Her mangler både grundlæggende viden om og interesse for miljøspørgsmål. Det er sandsynligt, at for at få disse gruppe i tale bør kommunikationen målrettes mod de værdier, der er fremherskende i grupper som f.eks. de personlige værdier eller egen sundhed samtidig med at vidensniveauet øges betydeligt hos begge segmenter.

Købsmotiver og kommunikation

En anden måde til at identificere gode og mindre gode kommunikationsstrategier for lavenergihuse er at tage udgangspunkt i forbrugernes købsmotiver. En undersøgelse af produkterne med højt miljøindhold, de økologiske produkter [Husmer, Jensen, Poulsen & Hjelmar 03] giver en oversigt over erfaringer omkring påvirkning af forbrugernes adfærd i relation til at inddrage miljøhensyn ved indkøb. I undersøgelsen indgår både erfaringer fra økologiske produkter såvel som andre produkter med større miljøindhold som A-mærkede hvidevarer, elektriske apparater og el-sparepærer. Redegørelsen konkluderer at :

- Prisen har vist sig at være den største barrierer for køb af produkter med større miljøindhold, samt at produkterne har vist sig at være meget prisfølsomme i forhold til konventionelle produkter.
- Manglende viden hos forbrugerne om miljøindholdet hos produkterne (hvor er forskellen egentlig)
- Manglende kobling mellem miljøeffektivitet og forbrugervalg – det er svært at se for den enkelte forbruger at se det gør en forskel at købe miljørigtigt. Forbrugerne har ikke tiltro til at de gennem ændring af deres vaner kan bidrage til at reducere miljøbelastningen.
- Manglende tillid og snyd – forbrugeren er i tvivl om man kan stole på producenten.

Iflg. undersøgelsen tegner der sig en smertegrænse for forbrugerne på ca. 10% for økologiske eller miljømærkede varer. Dog viser undersøgelsen også , at kampagner for at øge kendskabsgraden kombineret med direkte eller indirekte økonomiske incitamenter har givet markante resultater for bl.a. A-mærkede hvidevarer samt el-sparepærer. Skal denne tankegang følges, må det derfor vægtes højt i kommunikationen af lavenergihuse at fremhæve der ikke findes prismæssige barrierer for investeringer i lavenergihuse, men at den mindre prismæssige forskel der eksisterer mellem konventionelle huse og lavenergihuse hurtigt er tjent hjem. Sandsynligvis bør dette budskab dog formidles af en afsender uden direkte salgsmæssige interesser.

Nordisk – international perspektivering

Kan lavenergihuse sælges med samme argumenter i alle lande? For at besvare dette spørgsmål kunne det være relevant at se på værdierne på tværs af grænserne. Nordiske forbrugere ser ud til at være lidt forskellige specielt i forhold til hvor idealistiske eller personcentrede. En nordisk undersøgelse af livsstilsværdier i Norden som ACNielsen foretog i 2002 viser interessante forskelle. Nordmænd lader til at være mere tolerante, miljøbeviste og idealistiske end danskerne. Danskerne er derimod mere selvtilstrækkelige, hensynsløse og nationalistiske end både nordmænd og svenskere. Et produkt skal hellere sælges på personlig velvære end miljøbevidsthed i Danmark. Generelt ser det dog ud til at der er sket en ændring i købsmotivet for at købe miljøbevidst fra idealistiske og miljømæssige hensyn til mere egoistiske som eget velfærd. En situation, som også COOP har

erkendt i deres seneste økologiske avis: ”Glem den gode samvittighed og prøv det for din egen skyld”.¹³ Kaster man er kort blik mod vores sydlige naboer, hvor Passivhuse markedsføres i langt større omfang end på vores breddegrader ser man her også en mere idealistisk tilgang til kommunikationen som eks. Konstanz i Rothenburg Schweiz, hvor et gennemgående salgsargument blev ”et godt liv for børn”.¹⁴ Det vil derfor være lidt voveligt at antage at samme valg af retoriske strategier og argumenter i markedskommunikationen til virke på samme måde overalt.

Hvis det er en bedre forretning at investere i et lavenergihus – hvorfor køber forbrugerne dem ikke?

Dette spørgsmål blev stillet til en række af de husproducenter, som faktisk havde et salgsklart lavenergihus, men som ikke kommunikerede om det. Det generelle svar var, at forbrugerne ikke efterspørger produktet - de ved ikke ret meget om det og vægter det ikke i særligt omfang - og der derfor var så lidt volumen i dette produktområde, at det ikke kunne betale sig at investere i markedsføringsmateriale. Den mest kommunikerende virksomhed var dog ikke enig i dette synspunkt, men mente at der var en gruppe miljøbeviste forbrugere, som udmærket vidste, at det var en god forretning at spare på energien. Denne opfattelse som producenterne har, forklarer meget godt deres kommunikationsadfærd i forhold til lavenergihusene.

Hvad skal der til for at ændre situationen?

Tilsyneladende vil man kunne få samtlige segmenter i tale ved at vælge en kombination af idealistiske og egoistiske argumenter samt anvende et bredt spektrum af salgsargumenter, der taler til forskellige værdier som både de mere personorienterede som de mere idealistiske.

Det ser også ud til, at fællesprojekter har en tendens til øge kendskabsgraden til lavenergihusene i et langt større omfang end hvis de enkelte virksomheder øger deres kommunikation hver for sig. En søgning på presseomtale af lavenergihusene viser klart at fællesprojekterne er dem, der opnår mediernes gunst og får medieomtalen. Samtidig bør byggebranchen blive bedre til at registrerer forbrugerne større interesse for energi- og miljøområdet.

Sidst men ikke mindst ville det ikke direkte skade at forøge forbrugernes generelle informationsniveau omkring lavenergihusene. Som kampagnes omkring A-mærkede hvidevarer viste¹⁵, kan en informationskampagne forbundet med et økonomisk incitament gøre underværker og flytte både forbrugernes holdninger og adfærd.

Litteratur

- Miljøprojekt Nr 870 af Lis Husmer, Mette Lise Jensen, Jan Poulsen, Ulf Hjelmar. Miljøstyrelsen 2003.
Business Opportunities in Sustainable Housing. A Marketing Guide Based on Experiences from 10 Countries. IEA International Energy Agency 2006.
Beckmann, Suzanne C. m.fl.: Danske forbrugere og økologiske fødevarer. København 2001.
Hansen, Flemming: Forbrugeradfærd og beslutninger, Erhvervsøkonomisk Forlag 1987.
Vaughn, R. (86): How advertising works: a planning model revisited. J.of advertising Research Feb.Marts 86 p57-66.

¹³ Husstandsomdelt reklame for økologiske produkter fra Irma uge 40 2007, side 1

¹⁴ Business Opportunities in Sustainable Housing.

¹⁵ I løbet af to måneder mens kampagnen for A-mærkede kølefryseskabe løb i 1999, blev der solgt flere A-mærkede produkter end på et helt år. Miljø og forbrugeradfærd p.159

Hvordan selge passivhus

Eva Ekrem og Bård Haugen, Krogsveen Avd. Nybygg, Beddingen 2 Pb 8820, 7481 Trondheim
Åslaug Hennissen, Leiv Eiriksson Nyskaping as, Pb 1262 Pirsenteret, 7462 Trondheim

Skreddersydd kompetanseheving for boligmevlere

Leiv Eiriksson Nyskaping (LEN) utvikler en skreddersydd kompetansehevingspakke for boligmevlere i hvordan selge passivhus. Dette er viktig kompetanse for mevlere å tilegne seg. Mevlere rådgir og påvirker utbyggere, samtidig som de kommuniserer direkte med boligkjøpere. Krogsveen Avd. Nybygg er med som pilotbedrift i prosjektet.

LEN er det fremste verktøyet for nyskaping og vekst i Midt-Norge. LEN har 80 aksjonærer fra offentlige og private bedrifter i Midt-Norge. Dette er både industrielle, finansielle og akademiske aksjonærer. LEN har gjennomført 70 bedriftsinvesteringer, hvorav de fleste fortsatt befinner seg i porteføljen, og deltatt i ca. 40 emisjoner i porteføljeselskaper. Det er inngått 60 lisensavtaler med eksisterende næringsliv og LEN rådgir ca 900 gründere hvert år.

Krogsveen er et heleid datterselskap av Fokus Bank. Banken kjøpte i 2005 Krogsveen (grunnlagt i 1975), og i 2006 Meglerhuset Nylander (grunnlagt i 1936). Selskapene er nå fusjonert og fremstår nå under samme merkenavnet – Krogsveen. Krogsveen har 42 avdelinger i Norge, fra Stavanger i Sør/vest til Tromsø i Nord. Selskapet har ca 280 ansatte. Krogsveen omsatte ca 9000 boliger i 2007. Egen Nybyggavdeling som hovedsakelig jobber med salg og markedsføring av nye boliger.

Meglere hos Krogsveen Avd. Nybygg har gjennomført pilotkurset. Boligmevlere som har gjennomført kompetansehevingspakken settes i stand til enkelt å formidle videre kunnskap og selge inn passivhus. I løpet av 2008 skal kompetansehevingspakken gjøres tilgjengelig for alle mevlere, og den vil også ha overføringsverdi til boligprodusenter og boligutviklere som skal selge passivhus.

Markedsundersøkelser er et viktig grunnlag for boligmevlere

Det er utfordringer i dagens boligmarked. Mange boliger ligger for salg og det er kjøpers marked. Bankenes rentenivå oppleves uforutsigbart og mange advarer mot kjøp av bolig.

Det er også muligheter i dagens boligmarked. Faktorer som avgjør beslutning om kjøp er begeistring, forutsigbarhet, økonomisk evne og trygghet. Dagens boligsøkere er selektive, søker kvalitet, søker trygghet og søker identitet. Krogsveen ser muligheter ved salg av passivhus for å bevisstgjøre boligsøker som ved kjøp av ny bolig foretrekker egenskaper som gir boligen en merverdi, ønsker en bedre bolig for seg og sine omgivelser, ser langsiktig på en investering for fremtiden og vil bidra til å redusere klimatrusselen.

Før Krogsveen går i dialog med utbygger om passivhus gjennomfører de en markedsundersøkelse blant aktive boligsøker i sin database. Det er valgt et tilfeldig utvalg til undersøkelsen hvor spørsmål er sendt ut per e-post. Undersøkelsen er i tillegg lagt ut på Krogsveens nettside og intervju gjøres per telefon for å sikre et representativt utvalg. Det er viktig for Krogsveen å få kartlagt hos fremtidens boligkjøper:

- Hvilke faktorer som er avgjørende for kjøp av bolig
- Hvor stor kunnskap boligsøker har om passivhus



Meglere hos pilotbedrift Krogsveen

- Om økt kunnskap vil endre prioriterte valg dersom dette var mulig?

Analyse av undersøkelsen gjennomføres av LEN og resultatene fra undersøkelsen presenteres av Krogsvæn under konferansen Passivhus Norden 2008.

Innhold i kompetansehevingspakken

Innholdet i kompetansehevingspakken "Hvordan selge passivhus" utvikles av LEN i nært samarbeid med Krogsvæn Avd. Nybygg. Det er sentralt at et meglerhus er med i utviklingen for å være trygge på å treffe boligmeglere med språkvalget og kommunikasjonen, og slik at budskapet om passivhus treffer godt.

Kompetansehevingspakken består av fire moduler. Den første modulen inneholder overordnet informasjon om hvorfor det satses på passivhus og hvor utviklingen går i årene framover. Modul to omhandler hva passivhus er og hvordan boligene bygges. Modul tre tar for seg hvordan selge passivhus mot utbyggere og mot boligkjøpere. I denne modulen presenteres hva som har ført til salg i Europa, hva som har ført til salg i Norge og vår region fram til 2007 og resultater fra markedsundersøkelsene fra 2008. Modulen inneholder også eksempler på ulike meglerstrategier. Fjerde og siste modul presenterer forbildeprosjekter. Her er en presentasjon av pilotbedriften Krogsvæn Avd. Nybygg og presentasjon av ferdigstilte boligprosjekter.

Hvordan markedsføre energieffektive boliger?

Hovedforfattere av originalteksten:

Trond Haavik, Segel AS, 6770 Nordfjordeid

Synnøve Aabrekk, Segel AS, 6770 Nordfjordeid

Medforfatter: Edward Prendergast, moBius Consult, Nederland

International Energy Agency, SHC 28 / BCS 38

Sustainable Solar Housing



Bilde: Frontside av Anliker's salgsprospekt for passivhusboliger i Sveits

1 Introduksjon

1.1 Hvordan spre utbredelsen av energieffektive boliger?

Hvordan bygge energieffektive boliger eksisterer det i dag mye kunnskap om. Likevel skulle en ønske et høyere tempo i utbredelsen av de bærekraftige løsningene. Hva kan vi lære av de som har lyktes med markedsintroduksjon av lavenergiboliger? Konkret er spørsmålet om hvordan byggaktører som ser dette som en forretningsmulighet, bør gå fram i arbeidet med å lansere sine lavenergiløsninger i markedet. Denne problemstillingen var utgangspunktet for at Segel AS vart invitert til å studere ”suksesshistorier” fra flere land som deltok i IEA sin Task knyttet til lavenergiboliger; SHC task28 / ECBCS Annex 38: Sustainable Solar Housing.

1.2 Metode

Markedsgruppen i Task 28 utarbeidet en mal som de ulike ekspertene brukte som grunnlag når det beskrev suksesshistorier som de var involvert i eller kjente godt til i sine hjemland. Dette dannet grunnlaget for Segel sine analyser av de 18 casene fra til sammen 10 land. Konsulentselskapet som til daglig arbeider med å assistere selskaper med markedsutvikling, analyserte i hvilken grad de ulike casene hadde bevisste markedsstrategier i sin lansering eller ikke, og hva de vektla i sin kommunikasjon.

De mest interessante casene ble fulgt opp med intervju av nøkkelpersoner i prosjektene. 2 av prosjektene ble valgt ut til å brukes som illustrasjonscase i en engelskspråklig håndbok ble det viktigste resultatet av arbeidet. De to hovedcasene var knyttet til 2 bedrifter: Anliker AG, Sveits. REEP, Canada. Håndboken er ment å være et verktøy for selskaper som har ambisjoner om å gjøre en målrettet satsing på lavenergiboliger.

Alle deltakerne i markedsgruppen i Task 28 var viktige bidragsyttere til håndboken, som ble finansiert av Husbanken.

2 Eksempel fra Rothenburg i Sveits

2.1 Bakgrunn

Historien om passivhus fra Konstanz i Rothenburg handler om hvordan Anliker AG som det største entreprenørselskapet i Lucern regionen, valgte å utvikle og bruke ressurser på et produkt som var ganske nytt og ukjent i det sveitsiske boligmarkedet.

I utgangspunktet planla Anliker AG bare ordinære boliger på tomtearealet i Konstanz. En av arkitektene deres, Arthur Sigg, overbeviste imidlertid firmaet om at det lå en god forretningsmulighet i å utvikle bærekraftige boliger på denne tomten.

Hoveddrivkreftene for å utvikle passivhus var:

- å bygge bærekraftige boliger i tråd med firmaets filosofi (å bygge i henhold til en høy standard og samtidig sikre lave vedlikeholdskostnader)
- å skape aksept for og bevissthet om fordelene med bærekraftige boliger
- å lære hvordan man bygger og selger en ny type boliger
- å styrke firmaets image.

Sist, men ikke minst, skulle prosjektet forenes med hoveddrivkraften for alle bedrifter:

- å tjene penger.

For å redusere risikoen knyttet til bygging og salg av et nytt produkt, ble en variasjon av leilighetstyper tilbudt i det samme byggeområdet. Totalt planla og bygde Anliker tre ulike typer leiligheter:

- tre blokker består kun av passivhus kalt Vilette, totalt 12 leiligheter (to ekstra boligblokker ble bygd senere)
- fire blokker består av Minergie-leiligheter (tilsvarende lavenergiboliger), kalt Loft, totalt 32 leiligheter
- seks blokker består av 72 leiligheter kalt Veranda, og disse leilighetene er konvensjonelle.

Firmaet la ekstra vekt på å ta hensyn til miljøet på tomte. Samspillet mellom bygningens infrastruktur, grøntareal, boligareal og design ble optimalisert for å oppnå et godt bomiljø.

Teamet bak denne utviklingen av passive boliger i Konstanz var:

- Anliker AG: et konsern bestående av tre bedrifter, Anliker ervervet selv tomtearealet i tillegg til produkter og tjenester innen både prosjektledelse og bygging.
- Underleverandører: Anliker hadde hovedentreprisen, men leide inn underleverandører til betongarbeid, muring, taklegging, isolasjon, etc.
- Vitenskapelig ansatte ved Den tekniske høgskolen i Lucerne: ble invitert som ”tekniske ambassadører” for prosjektet, for å studere den nye teknologien som ble brukt og for å promotere og gi prosjektet vitenskapelig troverdighet.
- Bischof - Meier: en privat entreprenør som ble engasjert for å planlegge og ha ansvar for prosjektets markedsføringskampanje, utvikle informasjonsbrosjyrer og utføre annonsering.

2.2 Informasjonsinnhenting og analyse som grunnlag

Da Anliker startet planleggingen samlet de inn relevant informasjon, bearbeidet den og systematiserte og analyserte den. De var i stand til å utvikle de riktige strategiene og gjøre de riktige handlingene, og gjennom dette, oppnådde de en markedsføringssuksess.

2.2.1 Informasjonsinnhenting

Prosjekt-teamet for det passive huset baserte sine analyser på bl.a. følgende informasjon:

- Historisk sett er Sveits kjent som et land der beboerne hovedsakelig leier bolig. Bare en liten del av beboerne er boligeiere.
- I løpet av de siste årene har det blitt mulig å ta ut penger fra pensjonsfond for å finansiere kjøp av egen bolig.
- Blant en rekke lånetilbud, tilbyr Den kantonale banken i Lucerne to typer lån som fungerer som insentiver overfor den valgte målgruppen: a) familielån med en fast rentesats for 5 år redusert med 0.50%; b) et ”miljøvennlig” lån som kan brukes som tilleggsfinansiering når en kjøper en miljøvennlig og bærekraftig bolig.
- Miljøspørsmål har en viktig rolle på dagens politiske dagsorden. Sveits er et transittland for levering av ulike transportvarer gjennom Europa og sitter igjen med betydelig forurensning knyttet til denne trafikken.
- Energibehov i Sveits dekkes av vannkraft (30%), atomkraft (30%) og fossile ressurser som olje og gass (40 %).
- Minergie er et sveitsisk kvalitetsmerke for nye og renoverte bygg. Dette merket er et registrert varemerke og har full beskyttelse. Spesifikt energibehov brukes som hovedindikator for dette merket. Bare det endelige energibehovet er relevant.

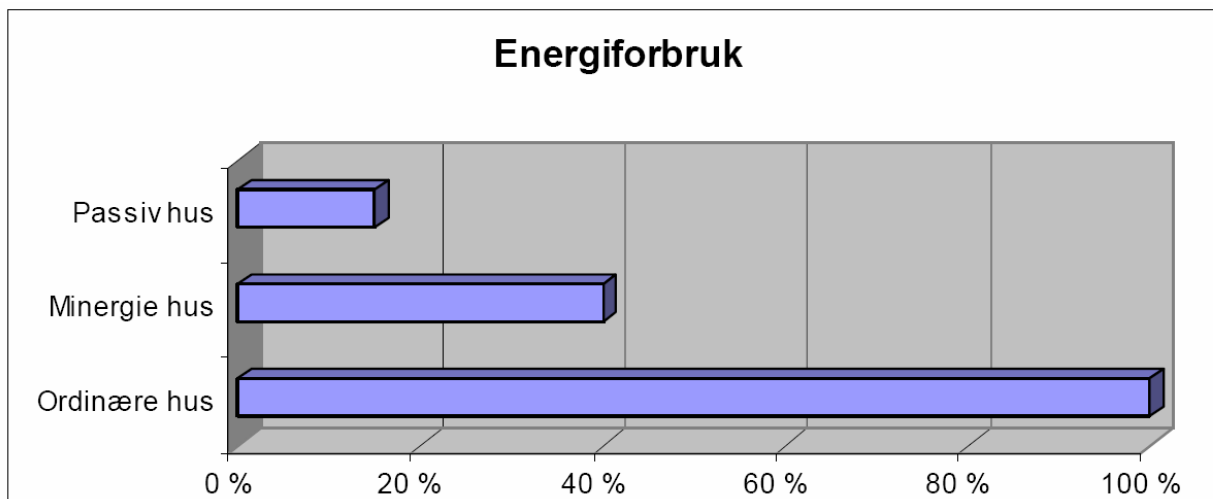

Figur: tre typene av boliger viser en enorm forskjell mellom energiforbruk i et konvensjonelt hus, et Minergie-hus og et passivhus, (referanse: Anliker).

Spørsmålene som det måtte tas stilling til var:

- Hvem vil være interessert i produktet?
- Hvordan er deres innflytelse i markedet?
Disse spørsmålene kan stilles til de ulike aktørene i markedet:
 - kunder
 - leverandører – underentreprenører
 - konkurrenter
 - komplementære bransjer
 - tilbydere av substitutter
- Hvem er de potensielle kundene?
 - Hva kjennetegner denne markedsnisjen?
 - Hva er behovene til denne nisjen?
- Hva er rett pris for produktet?
- Hvordan kan Anliker oppnå troverdighet for produktet?
 - Er det mulig å alliere seg med komplementære tilbydere?
 - Er det mulig å alliere seg med potensielle konkurrenter?

2.2.2 Markedsanalysen

Målgruppeanalyse

I Sveits er boligplanlegging svært fragmentert og sterk påvirket av banker og privat finansiering. Som tidligere nevnt tilbys det ingen økonomiske insentiver fra regjeringen i markedet for bærekraftige boliger. Dette innebærer at markedskreftene rår, og at kunnskap om ulike markedsgrupper (nisjer) er av stor betydning for de ulike aktørene.

Anliker identifiserte unge familier som en mulig markedsnisje for de passive husene. Det neste steget i analysen var å forstå målgruppen: hva er viktigst for denne gruppen av mennesker? Hva slags livssituasjon er de i? Hvilke behov har de?

Ved å analysere disse spørsmålene fant Anliker ut hva som er viktig for unge familier i deres markedsnisje. Unge familier og nye huseiere verdsetter:

- praktiske, økonomiske leiligheter tilpasset behovene til en ung familie med barn
- god arkitektur, design og miljøspørsmål
- et sunt oppvekstmiljø for barn

SWOT-faktorene for Anliker i forhold til markedsføringen av passivhus er summert opp i matrisen nedenfor.

<p>STYRKER Interne faktorer om organisasjonen og produktet (organisasjonen bør kjenne sine styrker og bruke dem som konkurransefordeler)</p>	<p>SVAKHETER (Opportunities) Interne faktorer om organisasjonen og produktet (organisasjonen bør velge aktiviteter som reduserer svakhetene deres)</p>
<ol style="list-style-type: none"> 1. Det største firmaet av sitt slag i regionen 2. Passende forretningsfilosofi: høy boligstandard og lav vedlikeholdsutgift 3. Vilje og drivkraft til å være innovative og gripe muligheter i markedet 4. God arkitektur, kvalitet og design 5. Hele firmaet står bak dette prosjektet 6. Godt rykte i markedet, og god service 7. Godt omdømme 	<ol style="list-style-type: none"> 1. 7% høyere byggekostnader 2. Liten erfaring med bygging av passivhus 3. Mangel på troverdighet med hensyn til bygging av passivhus
<p>MULIGHETER Eksterne faktorer som påvirker firmaets og produktets muligheter i markedet</p>	<p>TRUSLER Eksterne faktorer som påvirker firmaets og produktets muligheter i markedet</p>
<ol style="list-style-type: none"> 1. Et utappet marked med betydelig vekstpotensiale for passivhus 2. Økende bevissthet rundt miljøspørsmål i den valgte markedsnisjen 3. Å bygge etter passiv standard er en investering i framtiden 4. Reduksjon av fossile brennstoffer 5. Den kantonale banken i Lucerne stimulerer den voksende interessen for miljøvennlige alternativ med lavere rente 6. Media har miljøspørsmål høyt på dagsorden; gratis pressedeckning er mulig 	<ol style="list-style-type: none"> 1. Private finansieringskilder og banker påvirker markedet sterkt og bryr seg lite om å være en aktiv del av utviklingen i det private eiendomsmarkedet 2. Huskjøpere er fremdeles opptatt av etableringskostnader og er ikke så opptatt av løpende utgifter; utgifter til vedlikehold tas mye mindre hensyn til (disse er mye lavere for passive boliger)

3.1 Informasjonsinnhenting og analyse som grunnlag

Til å begynne med (2000) planla Anliker å bygge åtte passive boligblokker på Rothenburgområdet. Firmaet følte seg svært usikker på mottakelsen av det passive hus i markedet og valgte å starte med disse tre blokkene, selv om prosjektet til slutt endte opp med fem boligblokker bygd med passivhusstandard.

De viktigste hovedmålene for prosjektet var:

- Å bygge og selge tre passive boligblokker med totalt 12 leiligheter innen 2003 med følgende kriterier:
- maks 7% merkostnader sammenlignet med ordinær bygging
- økologisk bygd og med et svært lavt energibehov
- godt bomiljø og god arkitektur
- profitt på linje med å bygge konvensjonelle hus
- oppnå passivhus sertifikatet

3.2 Strategier

For å oppnå målene måtte Anliker bestemme strategier for hvordan de skulle utnytte mulighetene gjennom sine styrker og hvordan de skulle redusere trusselfaktorene. I tillegg til dette måtte de tenke på hvilke kritiske faktorer som var essensielle for deres potensielle kunder: hvilken type Produkt til hvilken Pris, hvor og når det skulle selges (Plass), og hvordan kommunisere med potensielle kunder (Promosjon).

Fordi de var utviklere av privat eiendom måtte Anliker også gjøre prosjektet til en kommersiell suksess: "Hvorfor bygge energieffektive hus når du ikke kan selge dem på grunn av at de er for dyre eller er arkitekturmessig lite attraktive?" Svaret var å designe en konvensjonell bygning hvor energiaspektene er så lite forstyrrende som mulig og som fokuserer på de elementene som er viktige for målgruppen.

3.2.1 Målgruppe

Målgruppen var unge familier som var innovatører og opptatt av miljøet.

3.2.2 Produkt

Fordi Anliker bestemte at det var for risikofyllt å bygge alle husene i henhold til Standard for passivhus, bestemte de seg for å bygge tre typer blokker:

- Veranda leilighetsblokker – konvensjonelle boliger
- Loft leilighetsblokker – i henhold til Minergie-standarden
- Villette leilighetsblokker – passivhus

Leilighetene har følgende karakteristika:

- attraktiv arkitektur
- bruk av naturlige materialer
- svært gode dagslysforhold
- fleksibilitet med hensyn til rominndeling
- store og grønne utearealer
- Passivhus-sertifikat

3.2.3 Pris

Markedet i Sveits er mye mer opptatt av anskaffelseskostnader enn av driftskostnader. Derfor var det viktig for Anliker å få byggekostnadene ned. De satte prisen 7% høyere enn for konvensjonelle boliger for å dekke opp for de forventede 7% høyere byggekostnadene.

3.2.4 Plass (salgsplassen)

Da de introduserte prosjektet inviterte Anliker interesserte boligkjøpere til flere informasjonskvelder på hovedkontoret sitt.

3.2.5 Promosjon med fokus på bygging av troverdighet

For å oppnå markedsgjennombrudd måtte alle involverte aktører ha tillit til prosjektet: entreprenører, underleverandører, spesialister og potensielle boligkjøpere. For å gjøre dette inviterte Anliker Den tekniske høgskolen i Lucerne til å teste boligene i forhold til standarden for passivhus.

Høgskolen har lisens til å utstede sertifikater for Minergie- og passivhus. Ved å få passivhus -sertifisering oppnådde Anliker umiddelbar anerkjennelse og troverdighet. Sertifiseringen fikk også god dekning i avisene og ga både firmaet og produktet ekstra markedsoppmerksomhet.

Kommunikasjon

Den store utfordringen for Anliker var å promotere økologiske boliger i markedet og imøtegå vanlige fordommer. For å sende ut det rette budskapet til målgruppen la de mye krefter i å kommunisere med sine potensielle kunder.

Bischof/Meier, et kommunikasjons- og markedsføringsfirma, ble leid inn for å definere markedsstrategien og for å utføre markeds kampanjen.

Det ble videre bestemt at kommunikasjonsstrategien ikke handlet om å fokusere på lavenergi, men om en måte å leve på. Energisparing og tilbakebetalingstid som tema ble derfor flyttet i bakgrunnen og målgruppens kjerneverdier ble tematisert: komfortabel og sunn levemåte for hele familien.

3.3 Handlingsplaner

I operasjonaliseringen av strategiene valgte Anliker å fokusere på markedsføringsaktiviteter.

Med utgangspunkt i analysearbeidet ble det sentrale fokuset å få markedsgjennombrudd og å skape positive assosiasjoner og oppfatninger om prosjektet.

3.3.1 Bygging av troverdighet

For å kunne bygge troverdighet i markedet måtte Anliker invitere andre strategiske partnere til å "delta" i prosjektet. På denne måten gjorde de prosjektet "offentlig" og tvang fram fokus på prosjektet framfor på utvikleren. Dette understreket prosjektets seriøsitet.

3.3.2 Kommunikasjon mot målgruppen

For å oppnå suksess var det helt sentralt å finne ut hva som var viktig for målgruppen de rettet seg mot: hva de foretrakk og hva de tenkte.

Mens de utviklet markedsførings- og kommunikasjonsplanen, og som et resultat av denne, valgte de å fokusere på tilleggsfaktorer som de oppdaget var viktigere enn kostnadsfokus for denne gruppen:

- livsstil
- kjernefamilieverdier
- lykkelige og sunne barn i godt inn klima
- trendy design
- grønne omgivelser med ren luft og bærekraft for kloden med lavenergi
- god arkitektur

3.4 Kontroll og måling

Ved å spille på trender både i utviklingen av leilighetene og når de kommuniserte med kundene på et senere tidspunkt, oppnådde Anliker en ekstra markedsføringseffekt for produktet i markedet. Flere krefter påvirket markedsnisjen positivt og resulterte i gode salgstall for firmaet.

Anliker kontrollerte resultatene i gjennomførte prosjektet mot de opprinnelig fastsatte mål som var å bygge og selge hus under følgende kriterier:

- maks 7 % merkostnader sammenlignet med ordinær bygging

- økologisk bygd og med et svært lavt energibehov
- godt bomiljø og god arkitektur
- profitt på linje med å bygge konvensjonelle hus
- oppnå passivhus sertifikatet

Anliker oppnådde sine mål innenfor tidsplanen. Suksessen til Konstanz' passive boliger ble bevist gjennom det raske salget av 44 leiligheter i syv blokker. I utgangspunktet planla Anliker å bygge 32 leiligheter av Minergiestandard, og 12 leiligheter med passivhus standard. Isteden for å bygge de planlagte 32 Minergie leilighetene, ble også disse bygget etter passivhus standard. Suksessen førte videre til byggingen av fem nye blokker.

Etter å ha evaluert en rekke informasjonskilder er Anliker sikker på at opp til 95 % av de potensielle kjøperne fikk den nødvendige informasjonen fra annonsene. Men de tror også at informasjonsdeling mellom potensielle boligkjøpere (familie og venner som fortalte hverandre om de passive boligene) hadde en enorm effekt på de positive salgstallene.

Prosjektregnskapet viser at Anliker oppnådde overskudd på linje med salg av konvensjonelle hus. Men helt sammenlignbare konvensjonelle leiligheter bygges ikke (med samme størrelse, design, etc.) og resultatet er derfor ikke helt sikkert.

4 Lærdommer på tvers av alle prosjektene

Det finnes ingen entydig og allmenngjørende resept på en "riktig" markedsstrategi for en bedrift sin satsing på energieffektive boliger. Hver må ta utgangspunkt i sine forutsetninger.

Der er likevel en del poeng som går igjen i flere av de gode eksemplene:

- Fokuser vesentlig mer på komfort i markedsføringen framfor energieffektiviseringen i seg selv. Eiere av bærekraftige bygg verdsetter de "ikke-energielaterte" fordelene mer enn selve kostnadsbesparelsene [Skumatz med flere 2000 og 2004]:
 - bedre luftkvalitet, reduksjon av astmaproblemer
 - høyere grad av varmekomfort på grunn av bedre isolering
 - et bedre hus; som vil være lettere å selge
 - tar ansvar for miljøet, spesielt i forhold til å forbedre lokal luftkvalitet, men også for å redusere global oppvarming
 - tar ansvar for framtidige generasjoner
 - bedre livskvalitet ved å bo i et bærekraftig hus
- Identifiser mulige alliansepartnere enten det er leverandører, konkurrenter eller tilbydere av komplementære tjenester/produkter.
- Når miljøspørsmålet er hetere på agendaen enn noensinne, så er mediene svært så sultne på de konkrete eksemplene. Dette åpner opp for mye gratis markedsføring.
- Strategisk fokus innebærer å være tro mot valgene man gjør. Skal man prøve å "dekke alt" vil en sjelden lykkes. Sentral bærebjelke her, er å bygge troverdighet. Et marked som er i endring gir økte muligheter for differensiering i forhold til konkurrentene.
- Synliggjør merverdiene som selskapets løsning bringer. Her er det sentralt å bevege seg utover de fysiske faktorene, og spille på det som kundene opplever.

REFERANSER

1 Skumatz, L.A., Dickerson, C.A og Coates, B., (2000), Non-energy Benefits in the Residential and Non-Residential Sectors – Innovative Measurements and Results for Participant Benefits, ACEEE Summer Study, Monterey, US, s.8.353-8.364.

2 Skumatz, L. and Stocklein, A. Using Non-Energy Benefits (NEBs) to market zero and Low Energy houses in New Zealand. SB04 Sustainable Building Conference, Shanghai (2004)

3 Haavik, T., Aabrekk, S., og Prendergast E., Business Opportunities in Sustainable Housing (2006).

Session 8

Workshop Training and education

Magnar Berge

Klimahuset ved Høgskolen i Bergen222

Magne Våge, Henrik Kofoed Nielsen, Bengt Michalsen

Planlegging og bygging av passivhus i Grimstad226

Short presentations from University of Aalborg, University of Lund,
University of Tampere and Norwegian University of Science and
Technology234

Klimahuset ved Høgskolen i Bergen

Magnar Berge, Høgskolen i Bergen, Avdeling for ingeniørutdanning, Postboks 7030, 5020 Bergen

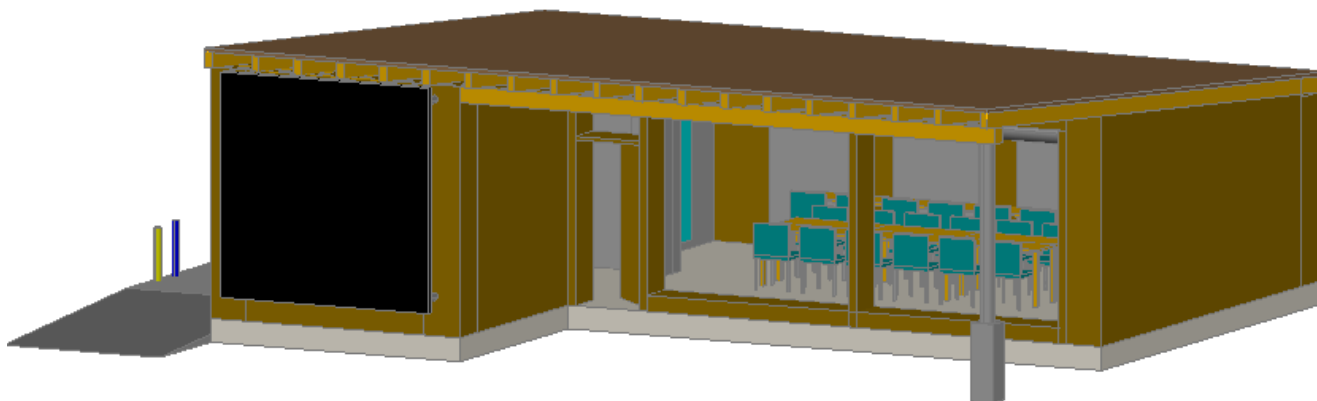

Bakgrunn

Høgskolen i Bergen planlegger å bygge et klimahus. Utviklingen og bruken av energilaboratoriet skjer i samarbeid av tre institutter: institutt for bygg- og jordskiftefag, institutt for maskin- og marinfag (studieretning energiteknologi) og institutt for elektrofag.

Klimahuset er tenkt brukt i undervisningssammenheng, ifm. studentoppgaver og FoU-prosjekt. For studentene vil bruken av energilaboratoriet gi mulighet for en praktisk tilnærming til problemstillinger og dermed gi et godt supplement til en teoretisk undervisning.

Beskrivelse

Bygget skal fungere som

- Energilaboratorium,
- Byggeteknisk laboratorium og
- Visningshus for passivhusteknologien.

Energilaboratorium

Som energilaboratorium vil en plassering utendørs gi muligheter for undersøkelser og tester under reelle klimabetingelser (inne-/utetemperatur, fukt, vind og solstråling). Forskjellige oppvarmingssystemer vil kunne installeres og brukes ifm. undervisning og student-/FoU-prosjekt.

Mht. fornybare energikilder vil en kunne installere og teste varmepumper, solfangere, solceller, biobrensel etc. Ventilasjonsanlegget vil kunne testes og innklimate overvåkes under reelle forhold.

En oppføring av et kjølerom gir mulighet for tester der konstante klimaforhold er nødvendig.

Byggeteknisk laboratorium

Med økende krav til redusert energibruk og innføringen av nye konstruksjonsløsninger øker også betydningen av bygningsfysikalske aspekter. Klimahuset vil gi muligheter mht. opplæring og tester i bygningsfysikalsk sammenheng. Byggetekniske detaljer kan synliggjøres, f.eks. ved delvis å ha glassplater som innvendig kledning på gulv, vegg og tak.

Kjøle-/fryserom

Det skal legges tilrette for å montere et kjøle-/fryserom med konstante temperatur- og fuktforhold. Veggen mellom kjøle-/fryserommet og grupperommet skal være utskiftbar. Her skal en kunne gjennomføre målinger av f.eks. temperatur- og fuktgjennomgang og bestemme U-verdi.

Klimaskjerm

Tak og yttervegger planlegges oppført med I-profiler, delvis med celluloseisolasjon og delvis med mineralull. Som dampbremse benyttes delvis OSB-plater og delvis PE-folie. Skjøter tapes. Som utvendig vindsperre bruker porøs trefiberplate/vindduk.

Det monteres temperatur- og fuktsensorer i flere sjikt i tak og vegger for å kontrollere fukttilstander for de forskjellige materialkombinasjonene over tid.

Utskiftbare veggelementer

Det er tenkt at komponenter i klimaskjermen (yttervegger, vinduer, tak) delvis skal være utskiftbare og/eller modifiserbare. En vil da kunne gjennomføre undersøkelser mht. energibruk og bygningsfysikalsk egnethet av de foreskjellige konstruksjonselementene, spesielt for vestlandsklima.

Med tanke på økende krav til isolasjonstykkelser skal nye vegg-løsninger testes og utvikles.

Ved rehabilitering av eldre bygninger er innvendig etterisolering ofte den eneste aktuelle løsning, noe som kan by på utfordringer mht. fuktsikkerhet, særlig ved store isolasjonstykkelser. Forskjellige løsninger vil kunne monteres og testes.

Utskiftbare vinduer

Innsetting av vinduer er et viktig tema mht. både varmetap og fuktsikkerhet. Det planlegges derfor å plassere vinduer på vestfasaden, som har den største regnbelastning. Her vil en kunne teste, overvåke og utvikle vindus og monteringsløsninger.

Visningshus

Erfaringer fra andre land viser at det er et stort behov for opplysning og bevisstgjøring av kvaliteter som passivhuset står for. Dette gjelder både overfor lovgivende myndigheter, byggherrer og bransjen forøvrig. I tillegg vil økt fokus på redusert energibruk og innføring av ny teknologi gi et behov for nøytral informasjon. Et visningsbygg som foreslått her vil kunne bidra til å dekke disse behovene. Potensielle byggherrer og andre aktører vil kunne se og oppleve et passivhus.

I grupperommet skal passivhustanken, energibruk/-tilskudd, bygningskomponenter, inn klima etc. synliggjøres på en lett forståelig måte vha. posters, skjermer, modeller osv.

Samarbeid med Fachhochschule Kärnten, Østerrike (FHK)

Høgskolen i Bergen samarbeider med FHK når det gjelder forsknings- og utviklingsprosjekter. I tillegg samarbeides det om student- og lærerutveksling. FHK har mye erfaring fra passivhus og testhus for bygningsfysikalske testing av bygningskomponenter. FHK har allerede bidratt mye i planleggingen av klimahuset.

FHK har et tilsvarende testhus under planlegging. Det planlegges å samarbeide om internasjonale forskningsprosjekt, der bygningskomponenter utvikles og testes under forskjellige klimaforhold.

Loggføring og visning måleresultater

Måleverdier skal loggføres kontinuerlig for pågående og fremtidige FoU-prosjekter. Dataoverføring skjer lokalt via Ethernet og via GSM for fjernavlesning.

Måleresultater skal også vises online, som vist i to eksempler nedenfor.

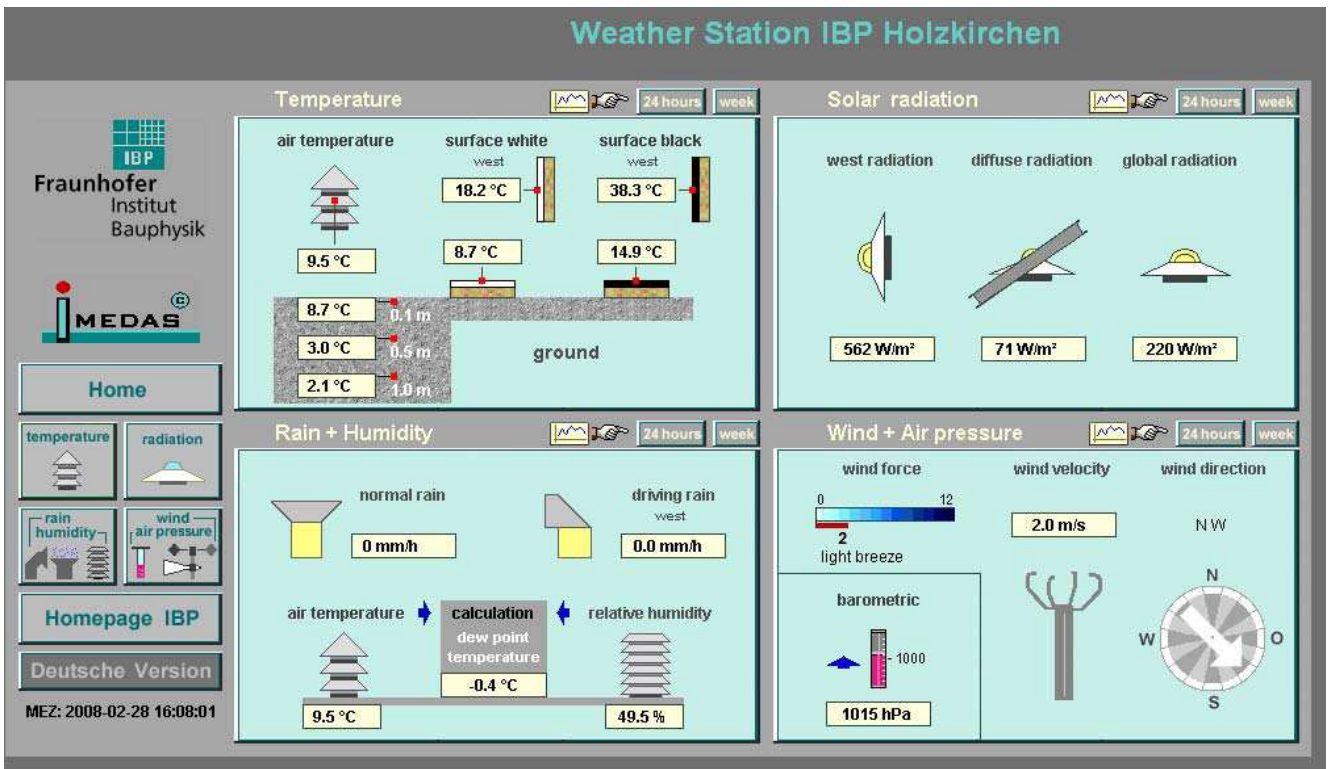

Figur 1 Eksempel online værstation [IBP]

Messwerte Versuchsfeld 1

Aktualisierung im 5-Minuten-Takt

Messwerte außen:

Temperatur: 8.25 °C

Feuchte: 84.4 %H

Niederschlag:

0 mm

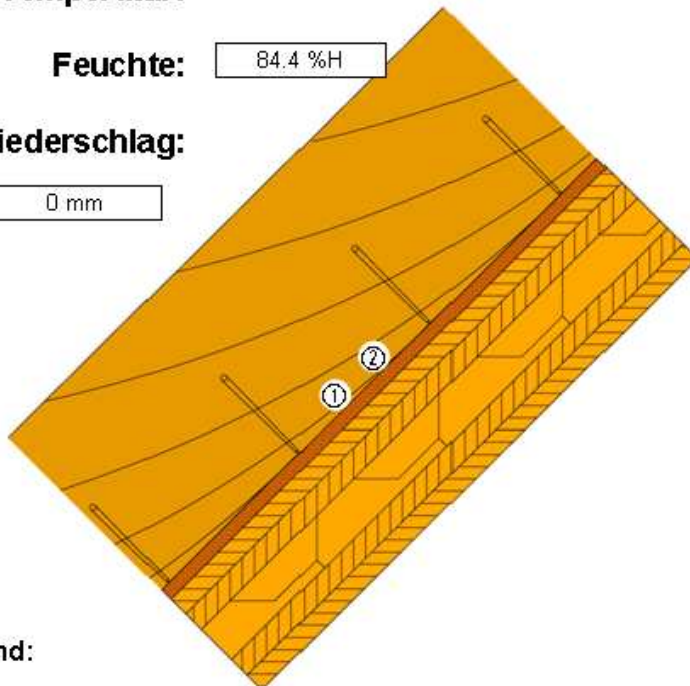

Stand:

15 : 55 Uhr

① Lage Temp. / Feuchte – Sensor

Temperatur: 13.33 °C

Feuchte: 59.1 %H

② Lage Holzfeuchtesensor

Holzfeuchte: 7.3 %

Messwerte im Innenraum:

Temperatur: 19.07 °C

Feuchte: 60.8 %H

Figur 2 Eksempel online visning av måleresultater [FHL]

Fremdrift

Første byggetrinn

Høgskolen i Bergen er for tiden i kontakt med forskjellige leverandører av selve råbygget og måleutstyr som skal bygges inn i konstruksjonen.

Montering forventes gjennomført sommer/tidlig høst 2008.

Andre byggetrinn

Andre byggetrinn består av komplettering av bygget og installasjon av ventilasjon, elektrisk anlegg og instrumentering. Dette planlegges gjennomført høst 2008/vår 2009.

Referanser

[FHL] FHL Forschungs GmbH, Regionalhaus Lübecker Bucht

[IBP] Fraunhofer Institut Bauphysik, Weather Station IBP Holzkirchen

Planlegging og bygging av passivhus i Grimstad

^aMagne Våge, ^aHenrik Kofoed Nielsen, ^bBengt Michalsen

^aUniversitetet i Agder

Serviceboks 509, 4898 Grimstad

magne.vage@uia.no

henrik.kofoed.nielsen@uia.no

^bArkitekt Bengt G. Michalsen AS

Lunde, 4885 Grimstad

bengt.michalsen@bgm.no

Sammendrag

Målet med dette prosjektet er å sette fokus på energibruk i boliger generelt og øke interessen for lavenergiboliger og passivhus spesielt. En flaskehals i denne sammenheng er formidling. I løpet av prosjektet skal kurs, seminar, frokostmøter og medieomtale bidra til å øke interessen for energieffektive boliger. Høsten 2007 er det arrangert to frokostmøter med omkring 30 deltakere og et seminar som samlet omkring 100 deltakere, dessuten har prosjektet fått bred omtale i lokalpressen ved flere anledninger. Et annet tiltak er å utarbeide et nettbasert kurs om prosjektering og bygging av passivhus. Den primære målgruppen for kurset er arkitekter og ingeniører, men kurset kan tilpasses og tilbys andre aktører innen byggenæringen. I den sidste del av prosjektet demonstreres bygging av passivhus. Her samarbeider Universitetet i Agder med arkitekt Bengt Michalsen og Husbanken om bygging av to eneboliger med passivhusstandard. Disse blir noen av de første passivhusene i Agder. Prosjekteringen startet i september 2007 og grunnarbeidet er igangsatt februar 2008. Det første huset skal være ferdig mai 2008. I løpet av høsten er det holdt 9 prosjekteringsmøter der ulike forslag løsninger for passivhusene er drøftet. Tre byggstudenter følger prosjektering og bygging av passivhusene som sitt bachelorprosjekt.

Innledning

EUs bygningsenergidirektiv [1] og fokus på klimaproblemet gir økt etterspørsel etter boliger med lavt energibruk i form av lavenergiboliger og passivhus. Etterspørselen forsterkes av kraftunderskudd og en forventet økning i energi- og elektrisitetspriser. I følge Dokka og Hermstad [2] er det pr. i dag ca. 3000 lavenergiboliger og passivhus, som er ferdigstilt, under bygging, eller under planlegging. Av disse er det er svært få som oppfyller kravet til og som kan betegnes som egentlige passivhus [3]. Passivhus har fått stor utbredelse i Tyskland og Østerrike, og etter hvert også i andre land i Europa som Sveits, Belgia, Nederland og Sverige [4]. er det er mange større og mindre passivhusprosjekt under arbeid, men mest leilighetskompleks.. Husbanken er en pådriver for mer energieffektive boliger, det vil si både lavenergiboliger og passivhus. Disse typer bygg, spesielt passivhus, stiller andre og strengere krav og rammer for handverksutførelse og arkitektonisk utforming enn "vanlige" boliger, noe som igjen betyr at behovet for bransjerettet etterutdanning og kurs er stort. NTNU har igangsatt et etter- og videreutdanningskurs i samarbeid med Husbanken. Kurset har hatt bra respons [3], men det eksisterer ikke noe tilbud om kortere eller nettbaserte kurs rettet mot bransjen. Det er ikke minst et behov for å formidle erfaring fra tidligere prosjekt. Det er mange aktører og fagdisipliner involvert i et byggeprosjekt og derfor er tverrfaglig kunnskap et viktig element i vårt prosjekt "Planlegging og bygging av passivhus i Grimstad". Prosjektet er et samarbeid mellom tre aktører; Universitetet i Agder, fakultet for teknologi og realfag, Arkitekt Bengt Michalsen gjennom sitt selskap Hemato Eiendom og Husbanken, regionkontor Arendal. Arkitekt Bengt Michalsen driver eget arkitektkontor og byggmesterfirma i Grimstad og er også en av tre gründere bak selskapet Aktiv Energi som tilbyr konsulent tjenester innen energibruk i bygg. Bengt Michalsen har vært en viktig lokal aktør når det gjelder markedsføring av energieffektive boliger og næringsbygg på Sørlandet.

Universitetet har både gjennom utdanning og forskning hatt sterkt fokus på fornybar energi og energieffektivisering gjennom snart 15 år. For to år siden ble det etablert en ny studieretning innen bachelor i

ingeniørfag-byggdesign. Studieretningens navn er energidesign og har blant annet energieffektive bygg, inneklime og energibruk som hovedtema.

Husbanken og Universitetet har en samarbeidsavtale, som omfatter blant annet formidling av energirelaterte tema gjennom seminar og konferanser, samt hovedprosjektoppgaver.

Problemstilling

Det er ikke tidligere igangsatt passivhusprosjekt i Aust Agder, selv om interessen for energieffektive boliger også er stor i denne landsdelen. En viktig grunn kan være at passivhus medfører økt investering og strengere krav til handverksutførelse enn for en "standard" bolig [2]. Kurs, informasjon og formidling av erfaring fra andre lignende prosjekt kan være viktige tiltak for å bryte ned barrierer og øke antall passivhus- og lavenergiprosjekt i Agder.

Et passivhus skal, ifølge Passivhusinstituttet i Darmstadt, blant annet ha et årlig oppvarmingsbehov som ikke skal overstiger 15 [kWh/m²] og effektbehovet skal være mindre 10 [W/m²] [5]. Passivhuskonseptet er basert på prinsippet om passiv energidesign [2], noe som betyr at det stilles krav både til klimaskjerm og utstyret i boligen.

Metode

I dette prosjektet har vi valgt å fokusere på formidling av kunnskap om passivhus til byggebransjen. For å nå bransjen inviterer vi til seminar og frokostmøter og vi vil på den måten gi anledning til å følge både prosjektering, planlegging og byggingen av to passivhusene i Grimstad. Vi inviterer blant annet VVS- og elektroentreprenører, eiendomsめklere, arkitektkontor og kommunene i regionen til å delta. I tillegg til dette utvikler vi et nettbasert kurs for å gjøre kunnskapen tilgjengelig for et bredere publikum og også etter prosjektet er avsluttet. Kurset blir tilrettelagt for ulike aktører innen byggenæringen, men basispakken vil primært ha arkitekter og ingeniører som målgruppe. Deler av kurset vil inngå i poenggivende kurs ved Universitetet i Agder. Hovedtema for kurset vil være prosjektering, planlegging og bygging av passivhus og lavenergiboliger. Erfaringer fra bygging av de to passivhusene i Grimstad brukes som eksempler sammen med erfaringer fra andre passivhus- og lavenergiboligprosjekt. Formidling vil også foregå ved at en av boligene fungerer som demonstrasjonshus. Boligenes energibruk vil dessuten bli fulgt opp gjennom ca. et år.

Boligene vil få lik form men med ulike tekniske løsninger, blant annet skal en av boligene ha naturlig ventilasjon

Innhold

Vi følger planlegging, prosjektering og bygging av de to passivhusene for at samle praktiske erfaringer og eksempler til kursmaterialet.

Planlegging og prosjektering av de to passivhusene i Grimstad startet september 2007 og er blitt fulgt av alle tre samarbeidspartene på 11 prosjekteringsmøter. På møtene er det drøftet ulike løsninger. Det er ennå ikke besluttet hvilke løsninger som vil bli implementert og vi ønsker at valgene skal begrunnes både med hensyn til energibruk, arkitektur, miljøbelastning og økonomi. Husbanken bidrar med økonomisk støtte både til byggingen av passivhusene og kursutviklingen.

Grunnarbeidene ble påbegynt februar 2008 og det første huset skal være ferdig omkring mai 2008.

Viktige spørsmål som har vært diskutert så langt i prosjektet er:

Tomt, boligtype og boligstørrelse

Her ønsker vi å legge vekt på følgende kriterier:

- Reguleringsplanen for området bør legge minst mulig begrensninger på valg av hustype.
- Tomten skal være lett tilgjengelig for interesserte fordi huset skal være visningshus.
- Tomten bør være solrik og skjermet for vær og vind.
- Området skal være attraktivt for kjøper, dvs. husene skal være attraktive salgsobjekt.
- Minst mulig av utearealet skal brukes til og vei
- Hovedfasadene skal være eksponert mot syd og at husene skal skygge minst mulig for hverandre
- Utearealene deles på boligene, det skal helst ikke være fellesareal.
- Boligene bør ha livsløps standard og universell utforming.

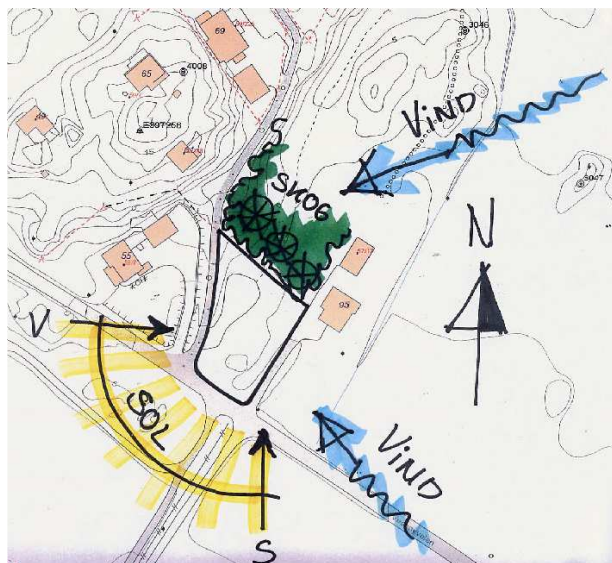

Figur 1. Kart over den valgte tomt på Vessøya, ca 1 daa

Utbygger hadde tre alternative tomter tilgjengelig, Vessøya, Myråsen og Trolldalslia, alle tre ville være brukbare alternativ for bygging av passivhus. Kriteriene som gjorde at tomtealternativ Vessøya i figur1 ble valgt var:

- Tomten er uregulert
- Tomten er lett tilgjengelig, da den ligger nær både riksvei og E18 mellom Arendal og Grimstad
- Landskapet er solrikt og flatlendt
- Tomten ligger sentralt i forhold til skole, barnehage, butikk, etc. på Fevik.

Spørsmålet om boligens størrelse og form, og om det skal bygges alternativt eneboliger eller tomannsbolig er også drøftet inngående. Tomannsbolig vil være et gunstig alternativ med hensyn til energibruk, mens den valgte tomtens størrelse og form favoriserer en løsning med to separate hus. Utbygger ønsket dessuten å bygge to like boliger som kan ha ulike tekniske løsninger.

Størrelsen på boligen var i utgangspunktet bestemt av markedet.

Energimålsetting

Planleggningen av passivhusene baserer seg på kriterier fra blant annet Dokka & Hermstad [2]. Kravene i tabell 1 er satt opp med med utgangspunkt i norsk klima

Tabell 1. Energikriterier [2] som legges til grunn i de to passivhusene. Tabellen inneholder også tilsvarende isolasjonstykkelse med mineralull.

Kriterier	Krav
Brutto energibruk ¹	85 [kWh/(m ² år)]
Kjøpt energi	65 [kWh/(m ² år)]
Total årlig energibruk	65 [kWh/(m ² år)]
Årlig oppvarmingsbehov	15 [kWh/(m ² år)]
Maksimal effekt til oppvarming	10 [W/m ²]
U-verdier og isolasjonstykkelse:	
Yttervegg	0,09 [W/(m ² K)], 400 [mm]
Yttertak	0,08 [W/(m ² K)], 500 [mm]
Gulv på grunn	0,09 [W/(m ² K)], 300 [mm]
Vinduer	0,7 [W/(m ² K)]
Ventilasjon (balansert)	
SFP faktor	1,5
Varmegjenvinner virkningsgrad	0,85
Årlig vifteenergi	4 [kWh/m ²]
Lufttetthet	N ₅₀ = 0,6 (N = 0,05) oms/h
Varmetilskudd	
Belysning	14 [kWh/(m ² år)]
Apparater	21 [kWh/(m ² år)]
Tappevann	35 [kWh/(m ² år)]

¹Inkludert oppvarmingsbehov kun i fyringssesongen

²Inkludert romoppvarming og tappevannsoppvarming i fyringssesongen som er satt til 4 mnd.

Vinterhage og inntak for ventilasjonsluft

Vinterhagens primære hensikt er å øke trivselen, men kan også gi tilskudd av passiv solvarme til resten av huset. I en vinterhage er det mulig å lagre solvarme i konstruksjonen, og forvarme friskluften til ventilasjonsanlegget. Friskluft kan også alternativt forvarmes i kanaler nedgravd i bakken. Dette er en kjent og utprøvd metode for å oppnå en stabil og høyere temperatur på ventilasjonsluften. På kalde dager kan da frisklufttemperaturen bli flere grader høyere enn utelufttemperaturen. Balansert ventilasjon og høyeffektiv varmegjenvinner gjør kulvert i bakken mindre aktuelt fordi tillufttemperaturen normalt vil være tilfredsstillende uten. Ved naturlig eller hybrid ventilasjon kan det derimot være behov for forvarming av friskluften og en jordkolektor kan derfor være en fornuftig løsning.

En oppvarmet vinterhage vil på årsbasis, selv med isolerglass, ha større varmetap enn gevinsten med passiv solvarme og det er derfor en forutsetning at oppvarmingen kun skal skje ved passiv solvarme. Uriktig bruk kan fort resultere i at vinterhagen blir et energisluk. I en vinterhage som brukes som vindfang vil det være fare for kondens på innsiden av glasset, fordi vinterhagen stadig tilføres fuktig inneluft.

Selv om det ikke er trukket noen endelig konklusjon, kan de se ut som om vinterhage ikke velges.

Solvegg og dobbel glassfasade

En solvegg kan gi energibesparelse og i tillegg signalisere noe nytt og innovativt, mens energisparingen trolig ikke vil kunne forsvare merinvesteringen for en enebolig.

Sonedeling

Det kan være aktuelt å redusere transmisjonsvarmetapene ved å dele inn boligen i varme og kalde soner. Varm sone vil da typisk være bad, kjøkken og stue/oppholdsrom og kald sone soverom, boder og andre ikke-oppvarmede rom.

I prosjekteringsmøtene har det vært fokusert spesielt på soverom som kald sone, men det er stor forskjell på folks ønsker til soveromstemperatur. Tiltak i denne sammenhengen kan omfatte ekstra isolasjon av skillevegger og eventuelt redusert ytterveggisolasjon. Dette er betydelig mindre økonomisk attraktivt for passivhus enn for konvensjonelle boliger pga. kort fyringssesong.

Varmegjenvinning fra gråvann

For et passivhus er energibehovet til romoppvarming svært lavt. Oppvarming av tappevann derimot er det samme som for en konvensjonell bolig og utgjør omkring halvparten av det totale energibehovet. Det er derfor nærliggende å se på tiltak som også kan redusere behovet for energi til tappevann. Tanken om å gjenvinne varme fra gråvann er ikke ny. Ulike løsninger beregnet for boligblokker, storkjøkkenet og lignende har vært på markedet i mange år, men det har til nå ikke eksistert noen ”hyllevareløsning” beregnet for enebolig. Økt fokus på energibruk og stigende energipris kan derimot skape etterspørsel etter slike produkter og derved flere innovative løsninger. Små enheter vil naturlig nok ha marginal lønnsomhet, men økonomien vil være avhengig av om tappevannsoppvarmingen er basert på direkte el. eller på solvarme. En konklusjon med hensyn til valg av løsning må derfor sees i sammenheng med valg av oppvarmingssystem.

Ventilasjon

Energieffektiv ventilasjon er en forutsetning for at passivhus-kravene skal kunne oppfylles[2]. For balansert ventilasjon betyr dette varmegjenvinner, med høy virkningsgrad og lav spesifikk vifteeffekt (SFP – faktor). Optimale løsninger for balansert ventilasjon krever også at det legges vekt på aggregatets plassering, kanalføring, trykktap og rengjøringsmulighet, dessuten muligheter for lede luften utenom varmegjenvinner ved sommerdrift. Den ene av boligene planlegges med naturlig eller hybrid ventilasjon, mens den andre skal ha konvensjonell balansert ventilasjon.

Naturlig eller hybrid ventilasjon vil bli tema på prosjekteringsmøtene fremover og det skal samles materiale fra lignende prosjekt.

Varmeanlegg

Et varmeanlegg i en bolig skal levere varme både til rom- og tappevannsoppvarming. Varmen kan genereres fra ulike fornybare kilder som; sol, biobrensel, varmepumpe eller kombinasjon av disse. Distribusjonen av varmen gjøres fortrinnsvis med vann og varmen avgis til rommet fra radiatorer eller varmelister i oppholdsrom og fra gulvvarme i bad og vaskerom. Det finnes standardsystemer som er tilpasset passivhus og lavenergiboliger, eksempelvis basert på kombinasjon solvarme og pellets eller solvarme og varmepumpe [8]. For et passivhus er energibehovet til romoppvarming i fyringssesongen svært lite og det kan derfor lett se ut som om direkte elektrisk oppvarming er den eneste fornuftige løsningen. Det er vil derimot være et stort behov for oppvarming også utenom fyringssesongen fordi komforthensyn krever oppvarming av gulv i bad og vaskerom gjennom hele året. I tillegg kommer behovet for tappevannsoppvarming.

Selv om et passivhus på rundt 150 m² kun har 2000 kWh som årlig energibehov til romoppvarming og ventilasjon i fyringssesongen, vil det årlige oppvarmingsbehovet, inklusiv tappevann utgjøre over 10 000 kWh/år. For å oppfylle passivhus-kravene vil det derfor være en forutsetning at oppvarming av rom og tappevann dekkes av en lokal fornybar energikilde.

Tegninger



Figur 2 Fasade syd-vest

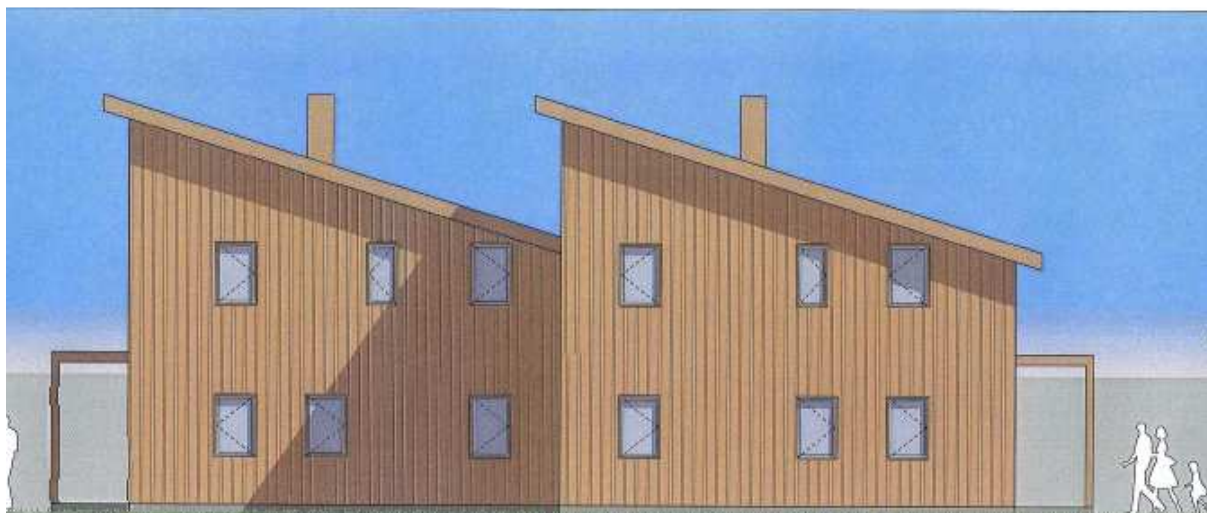

Figur 3 Fasade nord-øst



Figur 4 Fasade syd - øst



Figur 5 Fasade nord-vest

Resultater

Det er gjennomført 11 prosjekteringsmøter siden prosjektet startet i september 2007 der alle tre samarbeidspartene har deltatt. Prosjekteringsmøtene har gitt viktige innspill til arbeidet med kurset. Det ble gjennomført et seminar ved oppstarten av prosjektet, som samlet ca 100 deltakere og det er arrangert to frokostmøter om dette tema, hver med omkring 30 deltakere. Prosjektet har dessuten fått bred omtale i lokalpressen ved flere anledninger. Arbeidet med å lage et kurs om prosjektering og bygging av passivhus har foregått parallelt siden starten av prosjektet. Vi forventer at kunne levere materialet til Husbanken sommeren 2009. Grunnarbeidet er ferdig som planlagt og byggingen av de to husene vil starte før påske. Arbeidet med planlegging og prosjektering av de to passivhusene i Grimstad startet i september 2007

Konklusjon

Prosjektet har så langt vist at byggebransjen etterspør mere kunnskap om passivhus og energibruk i boliger og vi tror demonstrationhusene vil kunne medvirke til at bransjen oppfatter passivhus og lavenergiboliger som gode og realiserbare alternativ til boliger bygget etter Teknisk Forskrift 2007 (TEK97). Både oppstartseminaret og de to frokostmøtene bekrefter dette.

Kurset som utarbeides skal være ferdig sommeren 2009 og skal tilbys ulike aktører innen byggenæringen, men basispakken vil primært ha arkitekter og ingeniører som målgruppe.

Byggingen ser også ut til å starte som planlagt medio mars, slik at det første huset etter planen vil stå ferdig i mai 2008.

Henvisninger

- [1] Directive 2002/91/EC of the European Parliament and of the Council of 16 December 2002 on the energy performance of buildings
- [2] Dokka Tor Helge, Hermstad Käthe. Handbok for planlegging av passivhus og lavenergiboliger, SINTEF, Husbanken, Enova, 2006
- [3] http://www.passivhaustagung.de/Passive_House_E/PHPP.html
- [4] Business opportunities for sustainable housing. A Marketing Guide based on Experiences from 10 Countries. SHC Task 28/ECBCS Annex 28 Sustainable Solar Housing 105 PP,
- [5] http://www.passivhaustagung.de/Passive_House_E/PHPP.html#abb2. 8.03.2008.
- [6] <http://www.husbanken.no/Venstremeny/Miljo%20og%20energi/Stor%20interesse%20for%20EVU-kurs%20om%20lavenergiboliger%20og%20Passivhus.aspx>
8.03.2008
- [7] PEP, Promotion of European Passive Houses. Energy saving potential. May 2006 (EIE/04/030/S07.39990) , http://erg.ucd.ie/pep/pdf/Passive_House_Sol_English.pdf, mars 2008
- [8] Stene Jørn, Oppvarmingssystemer for boliger av lavenergi- og passivhusstandard, Rappr TR A6579, SINTEF Energiforskning, 2008
- [9] Stene Jørn, Oppvarmingssystemer for lavenergiboliger, Rappr TR A6182, SINTEF Energiforskning, 2006

Short presentations from University of Aalborg, University of Lund, University of Tampere and Norwegian University of Science and Technology

Paper missing.

Session 9

Workshop Standardization and certification

Susanne Dyrbøl, Kirsten Engelund Thomsen, Kim B. Wittchen

Member State approach towards a strategy for passive/very low-energy buildings236

Jyri Nieminen, Riikka Holopainen, Kimmo Lylykangas

Concepts and market acceptance of a cold climate Passive House242

Inger Andresen and Tor Helge Dokka, Thor Endre Lexow

New Norwegian Standard for Low Energy and Passive Houses250

Åsa Wahlström, Svein Ruud, Martin Erlandsson, Jonas Norrman, Eje Sandberg, Maria Wall, Hans Eek

A Classification of Passive House for Swedish Conditions256

Short presentation from Denmark260

Member State approach towards a strategy for passive/very low-energy buildings

Susanne Dyrbøl¹, EuroACE²

Kirsten Engelund Thomsen and Kim B. Wittchen, Danish Building Research Institute (SBI)

1 Abstract

One of the prescribed actions on buildings in the EU Action Plan on Energy Efficiency [COM(2006)545] is for the Commission to develop a strategy for very low-energy or passive houses (before 2009) towards a more widespread deployment of these building types by 2015.

In order to generate a picture of the current national approach in this area EuroACE has initiated a survey. The scope was to create an overview of current and planned strategies in the European countries regarding the implementation of requirements towards very low-energy buildings (on passive level or similar) in their national legislation.

The survey shows that many European countries already have taken national actions towards implementing requirements at the level of very low-energy buildings within a time frame of 5-12 years but only a few European Member States (MS) have plans for strengthening the requirements to the existing buildings which is even more important if Europe wants to achieve a major reduction in the overall energy used for conditioning buildings.

The current recast of the EPBD [Directive 2002/91/EC] is an excellent opportunity for the European Commission to follow up on the ambition in the EU Action Plan by introducing a request to MS to: define very low-energy buildings at national level, to draw up a national strategy towards this level of energy performance, and to put focus on upgrading energy performance of the existing building stock.

2 Introduction

In the EU Action Plan on Energy Efficiency, buildings have a key position. To assist the European Commission in the priority of developing a strategy for very-low energy or passive buildings this survey was initiated. The aim of the survey was to create an overview of the current activities in the European countries regarding very low-energy and passive buildings – in the following denoted very low-energy buildings. In the context of this survey, both types are intended to indicate buildings which are designed to a significantly higher standard of energy efficiency than minimum required by the National Building Regulations.

To collect the information a questionnaire was developed and distributed to official representatives for each of the 27 MS plus Croatia, Norway, and Switzerland. The activities in question were about the existence of low-energy building definitions, supporting legislation for promoting very low-energy buildings and strategies for the future.

The majority of the countries who answered the questionnaire has either an official or a non-governmental (NGO) definition of very low-energy buildings. Many countries have plans for their next revision of the energy requirements and at least seven countries have a schedule for introducing the level of very low-energy buildings as the minimum requirement for new buildings in their National Building Regulation.

¹Contact person: Susanne Dyrbøl, Rockwool International A/S, Hovedgaden 584, 2640 Hedehusene, DK. Phone +45 46558095, fax +45 46563311, e-mail: susanne.dyrboel@rockwool.com

² EuroACE is the European Alliance of Companies for Energy Efficiency in Buildings. The working group in EuroACE on this issue consist of: Susanne Dyrbøl (DK), Trine Albæk (DK), Kurt E. Eriksen (DK), Rick Wilberforce (UK), Marleen Bass (BE) and Monique Levy (FR).

Only a few countries have a strategy for improved energy efficiency of existing buildings (France and Belgium (Flanders)). If the energy consumption in buildings is to be reduced significantly over a limited time it is a necessity to increase the focus on improving the existing building stock as well.

3 Method

The survey has been conducted by the Danish Building Research Institute (SBI) and targets both official and non-governmental (NGO) approaches. The full report can be downloaded from www.euroace.org and www.sbi.dk. The questionnaire was circulated in autumn 2007 to official representatives from the 27 Member States of the European community plus Croatia, Norway, and Switzerland. 22 countries have responded to the questionnaire.

In the questionnaire activities organised by non-governmental organisations (NGO) were used as a general explanation for activities which are not directly anchored in governmental legislation, examples of non-governmental organisations in this relation are local energy supply companies, grass-root organisations, self-appointed certification bodies even if they have gained more or less official status.

From the responses it was possible to get an overview of the current status for very low-energy buildings in Europe. The answers have been analysed in the best possible way and supplemented by knowledge from the project group.

4 Results

4.1 Definition of very low-energy buildings

As shown in Figure 1 official definitions of very low-energy buildings exist in the following seven countries: Austria, Czech Republic³, Denmark, United Kingdom (England & Wales), Finland, France, and Germany.

Belgium (Flanders), Hungary, Luxembourg, Romania, Slovakia, Norway, Sweden, and Switzerland have plans for introducing an official definition. However, some of the plans are more developed than other.

The four countries with "only" a NGO definition are Ireland, Italy (Piedmont), the Netherlands and Poland.

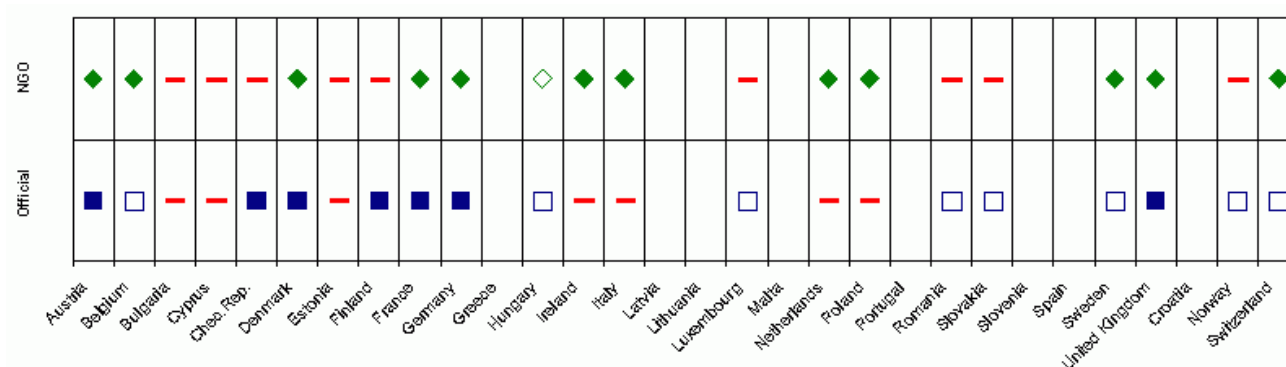

Figure 1: Countries with an existing (filled symbol) or planned (outlined symbol) definition for very low-energy buildings (official or non-governmental (NGO)). Countries without a definition, but who have returned the questionnaire, are marked by a dash (-). In total 5 countries have both an official and a non-governmental existing definition of very low-energy buildings.

³ In Czech Republic the implementation of the Energy Performance Certificate with the rating scale A-G has at the same time introduced an official definition of very low-energy buildings.

Figure 2 shows when official (blue rhombus) and NGO definitions (orange squares) of low-energy buildings were introduced in the different countries. The triangles indicate future plans for tightening of the energy requirements. Many countries have already planned as well as announced the future level of their energy requirements for the next revisions within the coming 5-10 years. Figure 2 does not say anything about the level of the tightening, only when it is planned to come into force. In most cases the planned tightening only covers new buildings, but France and Belgium (Flanders) do also have plans for existing buildings. Normally, in Denmark the strengthening of requirements for existing buildings will follow the level of strengthening for new buildings in case of radical renovations or change in use of an existing building.

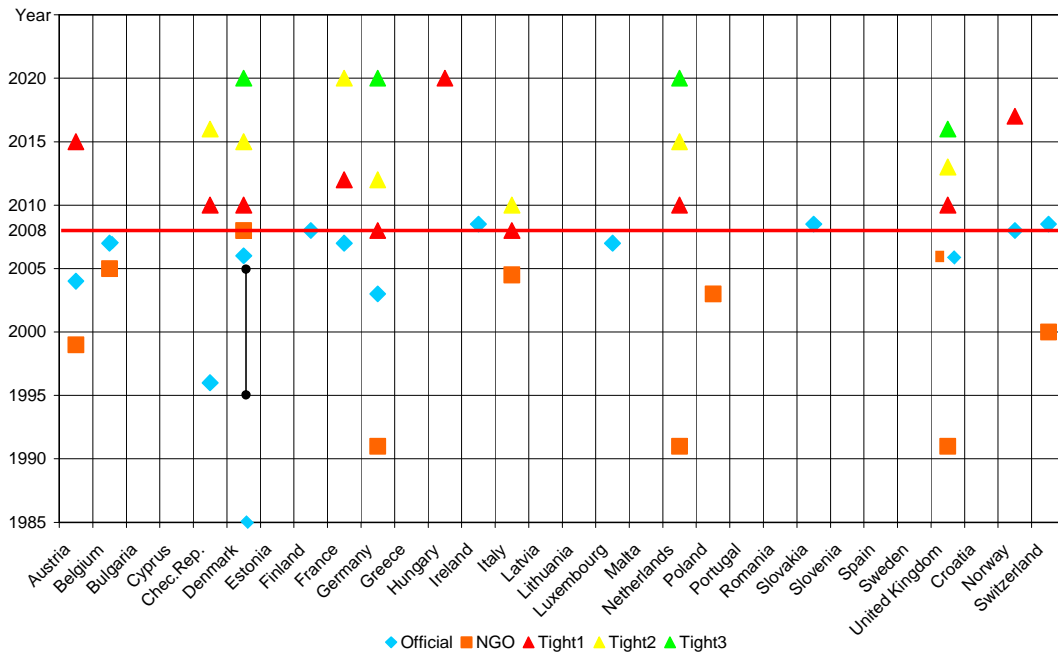

Figure 2: Introduction of a low-energy building definition (official and NGO) is shown as blue rhombus and orange squares, respectively. Planned tightening of energy requirements in Building Regulations are shown as triangles. The three levels of tightening shown in the figure do not represent the same level of tightening as this is individually decided for all countries. The vertical line for Denmark represents a period of time without any official definition of low-energy buildings.

4.2 Strategies for the future

The level of the planned strategies towards very low-energy buildings illustrated in Figure 2 are given in table 1 below.

Country/year	2008	2009	2010	2012	2013	2015	2016	2017	2020
Austria						social housing subsidies only for PH buildings			
DK			-25%			-50%			-75%
France				"low consumption standard" (Effinergie)					Energy positive buildings
Germany	-30%			-49%					Buildings to operate without fossil fuels
Hungary				0-emission buildings for "large investment buildings"					0-emission buildings
NL			-25%			-50% (PH level)			Energy neutral buildings
Norway		-30%						PH level	
UK			-25%		-44% (PH level)		0-CO ₂ , (Heating & lighting)		

Table 1 Overview of announced /planned development in energy requirement in national Building Regulations compared to current requirements.

By 2016 United Kingdom (England and Wales) aim for having zero-carbon requirements for heating and lighting. By 2017 Norway aims for having requirements similar to the German passive house level. In 2020 the requirements in Denmark will be reduced with 75% compared with the current level. Recently, Hungary as well has adopted a Climate Change Strategy aiming for having zero-emission buildings from 2020.

By 2020 France, Germany, and Netherlands aim for having all new buildings to be either energy neutral or energy producing. More details about the national plans can be found in Engelund et al, 2008.

4.3 Energy requirements for very low energy buildings

Comparison of the minimum energy performance requirements is not directly possible, as the assumptions and basis differ from country to country. For instance energy performance can be calculated by heated floor area, habitable area, or gross floor area and this can easily result in deviations of 10-20 %. Further it differs which energy consuming processes are included in the different calculations of the energy performance. However, in table 2 an attempt has been made to set up a quick overview of some of the definitions used for very low-energy buildings for the countries with fixed limitation in energy consumption.

Country	Energy requirements for very low-energy buildings
Austria	Low-energy buildings are buildings with annual heating energy consumption (calculated demand) below 60-40 kWh/m ² gross area (higher numbers for single family houses). Passive buildings are defined according to the passive house standard heating requirement less than 15 kWh/m ² where the area refers to net area according to Feist; in Austria, the indicator 15 kWh/m ² refers to useful area (Wohnnutzfläche) in Styria and to heated area (Energiebezugsfläche) in Tirol.
Denmark	In the current Building Regulation two low-energy classes are defined. Low-energy class 2 and low-energy class 1 are defined as having a calculated energy performance which is 25 and 50 per cent, respectively lower than the minimum requirement for new buildings. The minimum requirement for residential buildings is given by: 70 + 2200/A kWh/m ² per year (A is the heated gross floor area). For other buildings the minimum requirements are given by: 95 + 2200/A kWh/m ² per year. The minimum requirement for non-residential buildings includes electricity for building integrated lighting.
France	The "arrêté ministériel" from 8 th May 2007 defines regulatory requirements for energetic performance of buildings. This provision defines five levels: HPE, HPE EnR, THPE, THPE EnR, and BBC, the "Low Consumption Building". Base for the BBC label: For new dwellings: the annual requirement for heating, cooling, ventilation, hot water and lighting must be lower than about 50 kWh/m ² (in primary energy) (40 kWh/m ² to 65 kWh/m ² , depending on climatic area and latitude). For other new buildings: the annual requirement for heating, cooling, ventilation, hot water and lighting must be at least 50 % lower than what is required by the current building regulation for new buildings. For renovation, the Grenelle de l'Environnement is likely to adopt a BBC label of 80 kWh/m ² a year for heating/cooling, ventilation, hot water and lighting, starting in 2009.
Germany	Governmental definitions concerning the public subsidies for (residential) low-energy buildings are subjects of the program run by the (state-owned) Kreditanstalt für Wiederaufbau, Frankfurt (KfW). The current requirements have two levels which are KfW60 or KfW40. For a KfW60-building the primary energy demand is limited by 60 kWh/(m ² a), and the quality of the building envelope is 30 % better than the EnEV level. A KfW40-building the primary energy demand is limited by 40 kWh/(m ² a), and the quality of the building envelope is 45 % better than the EnEV level. In addition, there is a subsidy program for "Passiv-Häuser", which is defined in accordance with the Passiv-Haus-Institute as "KfW-40-buildings with an annual heat demand lower than 15 kWh/m ² ".
United Kingdom (England & Wales)	Indicative timetable to become regulatory requirement: 2010 (25 % better than current regulations); 2013 (44 % better - similar to Passiv Haus); 2016 (zero carbon requirement for heating and lighting).

Table 2: Examples of definition of very low-energy buildings used in selected MS

Feil! Objekter kan ikke lages ved å redigere feltkoder. Figure 3: Comparison of the Danish, Swiss, French and German performance standards which are all expressed in kWh/(m²·year). But the scope, calculation method and norms differ. Source [Eveillard 2007].

4.4 Incentives to promote very low-energy buildings

The incentives to promote low-energy buildings vary among the European countries. The incentives range from no direct promotion and only marginal indirect incentives to direct financial support on various levels. The most used direct support for low-energy buildings is loans with low interest rate to finance low-energy buildings. This is done either by means of governmental subsidies or via private investment organisations. Lower taxes for low-energy buildings are another major tool to promote this kind of buildings.

To supplement the direct incentives a number of indirect incentives do exist in the European countries. Examples of this are: simplified heating billing requirements, no obligation to take public heat supply, CO₂ taxes, certification or labelling of the low-energy buildings.

5 Conclusion and recommendation

A large number of countries have already introduced a national definition of a low-energy building. However, a cross country comparison of the requirement level is very difficult to create due to national deviations in both definitions and calculation principles.

Many countries have announced their plans for the coming revisions of their energy requirements, and several countries have targets for new energy requirement in 2015 and 2020. A long term objective is an effective instrument to achieve highly energy efficient buildings, as well as a valuable tool and guideline for the construction sector to prepare for the development.

It is important to stress the need for MS to introduce national or regional definition of very low-energy buildings and to develop a national strategy towards making this level become the standard. The market transformation towards very low-energy buildings is a big challenge for all the partners in the building sector and the building sector has just started the “learning curve” from having the concept of very low-energy buildings as a “grass-root” concept to become an official requirement in a very short timeframe.

It is important that the European Commission initiate actions to follow up on the ambition in the EU Action Plan – to develop an EU strategy towards very low-energy houses. The current recast of the EPBD is an opportunity which must not be missed to introduce the requirement to MS to define very low-energy buildings and a national strategy towards this level of energy performance.

A strategy for improved energy efficiency of existing buildings is a necessity if the energy consumption is to be reduced significantly over a limited time. The life time of buildings is between 50 and 100 years and improvement of the existing building stock will thus have much higher impact than tightening of requirements for new buildings.

6 Acknowledgment

Our sincere thanks to all the people who kindly helped us with national information.

7 Reference

- | | |
|------------------------|--|
| [COM(2006)545 final] | COM(2006)545 final. Action Plan for Energy Efficiency: Realising the Potential |
| [Engelund et al 2008] | Engelund et al, European national strategies to move towards very low-energy buildings, SBi, (2008) |
| [Directive 2002/91/EC] | Directive 2002/91/EC of the European Parliament and of the Council on the energy performance of buildings. |
| [Eveillard 2007] | Eveillard, Effinergie presentation « Enjeux et référentiel », March 2007. |

Concepts and market acceptance of a cold climate Passive House

Jyri Nieminen, VTT, jyri.nieminen@vtt.fi
Riikka Holopainen, VTT, riikka.holopainen@vtt.fi
Kimmo Lylykangas, Helsinki University of Technology, kimmo.lylykangas@hut.fi

Introduction

The properties of the Finnish passive house were defined by VTT in the European research project Promotion of European Passive Houses (PEP) funded by Intelligent Energy Europe program in FP6:

- The total primary energy use for appliances, domestic hot water and space heating and cooling is limited to 130 – 140 kWh/m²,
- The total energy demand for space heating and cooling is limited to 20 - 30 kWh/m² floor area;
- The air tightness of the building envelope $n_{50} \leq 0.6$ 1/h

The energy demand is defined to be higher than the corresponding demand in Central Europe. Energy simulations [Ståhl 2002] have shown that a Passive house in the climate of Central Finland would require insulation (thermal conductivity $\lambda = 0.035$ W/mK) thicknesses of 50 - 60 cm in exterior walls, 70 - 80 cm in the roof, and roughly 40 cm in the floor to fulfil the Central European requirement. At the same time window area should be minimized, and the total window U-value should be less than 0.5 W/m²K. The economic viability of such a building is rather low, and thus the Central European definition is not justified.

The heating energy-saving potential of passive house is at least 75 % of the current standard of construction in all climates in Europe. The experiences gained in Central Europe are not directly applicable in the Nordic or Baltic cold climate zones. There are several issues that restrict the use of existing passive house systems in cold climates, e.g.:

- The demonstrated concepts do not fulfil the energy demand requirement in a cold climate
- The hygrothermal performance of typical passive house building systems may not be appropriate
- The frost conditions in cold climate require foundation thermal insulation measures that have not been tested or provided with appropriate instructions
- The ventilation heat recovery efficiency is affected by defrosting that reduces the yearly efficiency of that of the best practice in milder climates
- The traditional Nordic heat supply systems are not applicable to passive houses due to high heat release power, and thus the user sensed thermal comfort differs of that typical, e.g., in Finland

If the passive house concept can be widely adapted to new construction the concept offers an important possibility to reduce the overall CO₂ emissions in Europe.

The definition of a passive houses bases on the energy demand. The aim of a passive house is also the use of renewable and low-emission energy sources. The total energy demand of a passive house refers to total primary energy demand. The problem with the primary energy approach is the use of conversion factors, as requested. Consumers can order, e.g., wind electricity via the grid. If the conversion factor refers to all electricity from the grid, the method does not promote the development of renewable energy supply. As such the conversion to primary energy is not applicable.

Thick insulation layers necessitate special attention to be paid to the performance of the structures. Frost protection of foundations, drying capacity of insulated structures, avoidance of thermal bridge effects, and long term performance of the airtight layers need to be considered. The concept development and construction of the first Finnish Passive houses tackled these challenges.

Experiences on ventilation heating systems show that simple heating systems are viable also in the cold climates. The increased heating power demand compared to climates in Central Europe does not reduce the indoor air quality. Room based control enables varying room temperatures according to specific needs of the users.

Passive house design

Building envelope

A passive house for a cold climate requires a high thermal insulation level. A passive house can be built of different building systems, and there is no special material dependence. The importance of thermal mass is also quite low in a cold climate. As the heating season is short, only 4 – 6 months, passive solar heating has also a low importance – there is only few sun shine hours in the midwinter months from November to January.

Passive house design requires accurate knowledge over the properties of building component. The effects of thermal bridges need to be included into the thermal transmittance of the building envelope. Therefore the design bases on more accurate U-value calculations than, e.g., required by the building code. The following indicative properties for thermal insulation of the building envelope help for structural and energy design of the house:

- Wall 0.07 – 0.1 W/m²K
- Floor 0.08 – 0.1 W/m²K
- Roof 0.06 – 0.09 W/m²K
- Window 0.7 – 0.9 W/m²K
- Fixed window 0.6 – 0.8 W/m²K
- Door 0.4 – 0.7 W/m²K

Ground conditions vary in different parts of the country. During a cold winter the ground may freeze down to 1.5 meters in Southern areas, and even down to 2.5 meters in Lapland. These conditions require special attention to foundation system design. Basically, depth of the foundation bed in the ground, heavy foundation insulation, or change of ground mass to non-frosting soil removes the risk. In a typical building the floor heat loss is used for reducing the frost heave risk. As the thermal transmittance of the floor is very low, the heat loss is not applicable any more. Therefore the risk need to be analysed carefully, as the guidelines for foundation design do not cover floor structures with U-values below 0.15 W/m²K.

Heating demand

Internal heat loads cover a large part of a passive house's heating demand. Table 1 and Figure 1 show the dependence of the heating demand on the various properties in the climate of Helsinki. The risk of freezing of heat recovery unit is a problem connected to cold climate solutions. The energy performance requires an average heat recovery efficiency of more than 75% in the climate of Helsinki at the same time as defrosting is needed. Defrosting by heat or cyclic use of heat recovery for reduces the efficiency of heat recovery. Thus other ways and means should be applied as far as possible.

Subsoil heat exchanger for preheating of supply air may reduce or eliminate the defrosting demand. [Ståhl 2002] and [Thevenard 2007] give the following guidelines on the performance and possible problems with solutions for subsoil heat exchangers for a cold climate:

- Performance
 - 30 - 100% of the cooling demand in summer
 - Prevent freezing in the heat exchanger unit
 - Energy gain 1200 kWh with minor increase of intake fan power
 - Tube length 10 - 100 m
- Potential problems
 - Moisture control: mould and bacteria growth
 - pipes with a 2-3% slope, water collects at the lowest point, pumped out;
 - intake filters to prevent the entry of spores, insects, etc into the system;
 - access to the pipes for easy cleaning;
 - anti-microbial coating on the pipes.
 - Radon seepage from the soil: Airtight tube with connections

In the light of possible problems, subsoil heat exchanger can not be recommended to be used in a cold climate. However, ground heat is a possibility by using a heat well of ground loop system integrated with a heat exchanger to pre-heat the fresh air. This system will be used in the first passive house to be built and certified in Finland.

Building envelope					
Component	m ²	a) W/m ² K	b) W/m ² K	c) W/m ² K	d) W/m ² K
Wall	343	0.12	0.1	0.09	0.09
Basement wall	110	0.12	0.1	0.08	0.08
Roof	235	0.1	0.07	0.07	0.07
Floor	235	0.15	0.15	0.1	0.1
Window		0.8	0.8	0.7	0.7
- South	6				
- East	8				
- West	30				
- North	6				
Doors	16	0.4	0.4	0.4	0.4
Air tightness					
n ₅₀ value	1/h	0.6	0.6	0.6	0.6
Ventilation					
Rate	l/s	2 x 76			
Heat recovery	%	70	75	75	80
Spaces					
Gross floor area	2 x 235 m ² According to external dimensions				
Treated area	2 x 187 m ² According to internal dimensions				
Gross volume	2 x 844 m ³ According to external dimensions				
Volume	2 x 540 m ³ , room height: downstairs 2,6 m, upstairs 3,2 m				

Table 1. Properties for heating energy demand calculations for a passive house in Helsinki

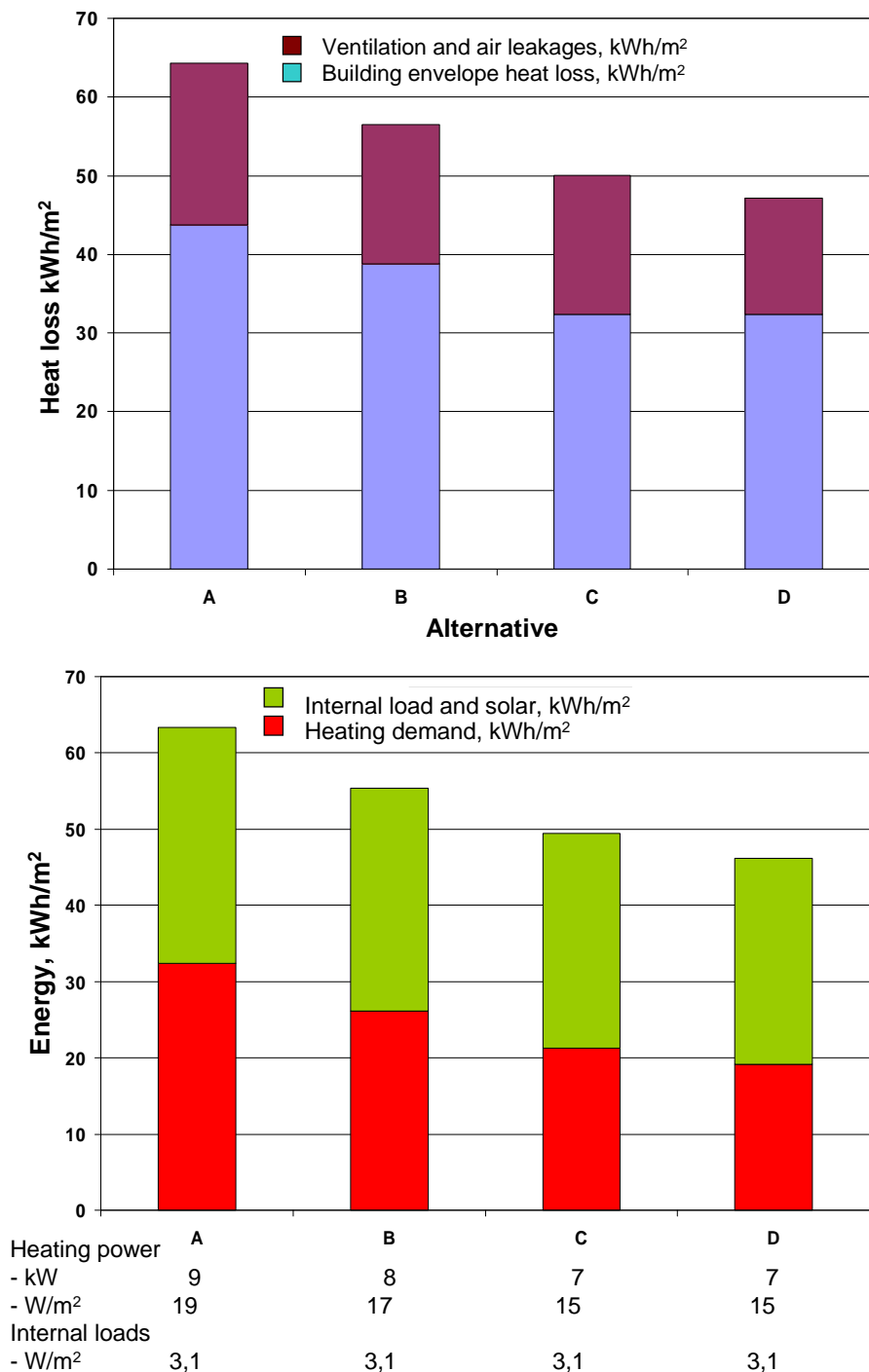

Figure 1. Passive house's heating demand according to different properties of the house [Nieminen et al. 2008]

Pilot projects

Interest in passive houses has increased in Finland. Several projects started in 2007. Two passive house projects under construction serve as pilots where different technologies and parameters are being tested. The Vantaa passive house is a two storey two family house, Figure 2. Building is a massive building with exterior insulation composite system as thermal insulation.

The Valkeakoski passive house is a wooden single family house, Figure 3. The load-bearing structural system is a modified Nordic Platform with I-beam wall structure and internal floor. Basic structural details of the system are at <http://www.puuinfo.fi/>.

Both buildings have a trussed roof. The properties of these buildings are given in Table 2.



Figure 2. Passive house Vantaa.



Figure 3. Passive house Valkeakoski

Building envelope			
House		Vantaa	Valkeakoski
Wall	W/m ² K	0,1	0,08
Basement wall	W/m ² K	0,1	-
Roof	W/m ² K	0,07	0,07
Floor	W/m ² K	0,10	0,10
Window	W/m ² K	0,8	0,75
- South	m ²	6	30
- East	m ²	8	2
- West	m ²	30	1
- North	m ²	6	42
Doors	W/m ² K	0,7	0,7
Air tightness			
n ₅₀ value	1/h	0,6	0,6
Ventilation			
Rate	1/s	2 x 76	
Heat recovery	%	80	80
Spaces			
Gross floor area	m ²	2 x 235	290
Gross volume	m ³	2 x 844	1200

Table 2. Properties of a passive house for heating energy demand calculations for a passive house in Helsinki

Both the Vantaa and Valkeakoski passive houses have a ground preheating system for the ventilation fresh air. In the Vantaa house, two 100 m loops locate at 2 m depth in the ground. In the Valkeakoski passive house, a heat well will be utilized. The estimated energy gain from the ground loop system net energy gain from the ground is roughly 1000 kWh. The heating system in the Vantaa passive house is ventilation heating. The room based heating power demand varies from 2 kWh/m² up to 36 W/m² in different spaces of the house.

Energy demand

The pilot buildings' energy demands were simulated using VTT House simulation program. VTT House is a non-commercial building simulation application with integrated calculation of heat transfer and fluid flow processes.

Heating power demand, kW

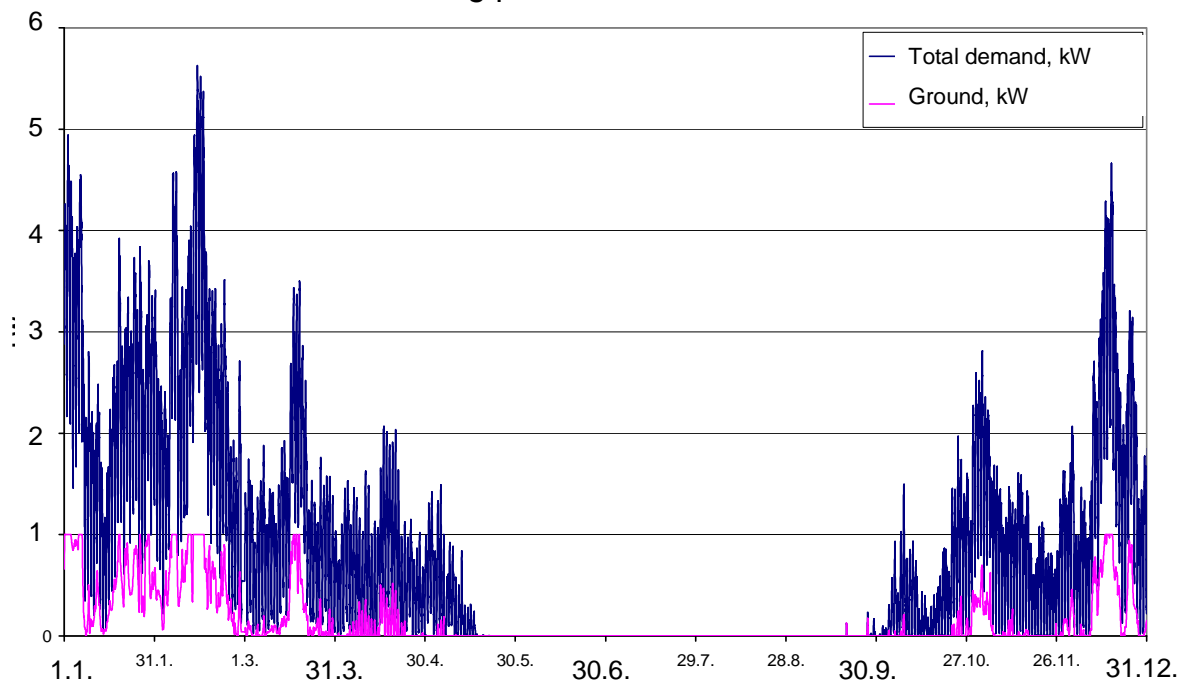

Figure 4. Hourly heating power demand of the Vantaa passive house [Nieminen et al. 2008]

Figures 4 and 5 show the hourly heating power demand and heating energy demand of the Vantaa passive house. The total heating power demand is 6.6 kW or 14 W/m² without ground source preheating of ventilation fresh air, or 5.6 kW or 12 W/m² with ground heat. The total heating energy demand is 18 kWh/m², however, the expected heat recovery efficiency requires reduction in the defrosting energy loss.

The Valkeakoski passive house is now under design phase. The calculated heating energy consumption is 30 kWh/m², according to specifications in the table 2. The required demand level is 25 kWh/m². To meet the demand, e.g., window area needs to be limited by 20 m².

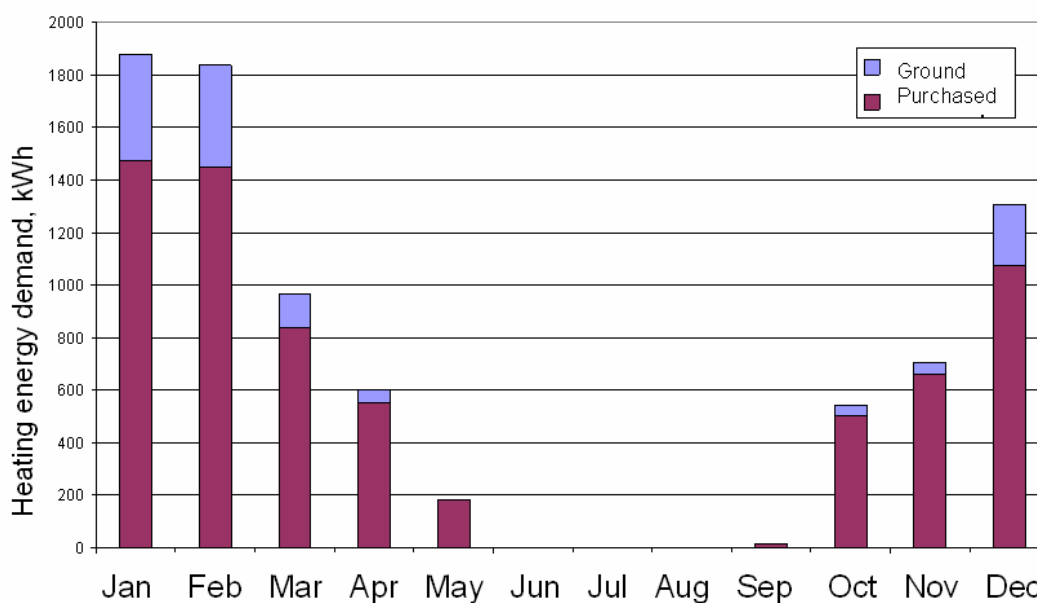

Figure 5. Space heating demand of the Vantaa passive house (Nieminen et al. 2008). The total space heating demand is 18 kWh/m². The estimated utilizable ground heat supply is 1200 kWh.

Market acceptance

A barrier for a successful implementation of Passive Houses is the absence of commercially viable concepts and suitable products on the market. Products, components and subsystems for Passive Houses have this far mainly been developed and adopted for German conditions. These products may not be fully suitable for North European circumstances. Many of them are also locally produced in small numbers and therefore not available on the North European market.

Building owners usually focus more on architecture and comfort than on energy use, when they look for a new home. It would therefore strengthen the promotion of the Passive House concept in the North European countries, if Passive House concepts were known for both a very low energy use as well as an excellent indoor environment. In this respect the indoor environment covers many aspects and includes both thermal comfort, indoor air quality, daylighting quality as well as acoustical qualities and it is important to focus both on objective quality of the indoor environment as well as the occupants perception.

Sustainable housing will be a growing part of the housing industry, making it a business opportunity waiting to be explored. There is need for user-oriented specific and systematic schemes for speeding up the market penetration of Passive Houses. The user-oriented approach means that the needs and demands of the customers (= Passive House buyers and constructors) are defined and the marketing scheme is tailored to the customers needs: thermal comfort, low energy bill, good indoor air quality, appealing architecture etc.

<p>Strengths: Solutions for Passive Houses exist. Buyers have a strong interest on low-energy building Environmentally sustainable building has clear benefits both in building and district level Building processes have been widely developed Development of industrial building and development ICT of design and building</p>	<p>Weaknesses: The quality of building is not high enough for Passive House building Dimensioning of building service equipment: old solutions, lack of balanced examination of the characteristics of heating demand dimensioning, building service equipment and building envelope -> over-dimensioning of the heating demand. Not enough capability for building air-tight houses No proper (tested) high-quality solar heating systems</p>
<p>Opportunities: Climate change threat is affecting the attitudes of the public and the persons in high business posts Internet is an effective data source for disseminating the benefits of low-energy and Passive House building ICT may ease the participation of the buyer to the building design ICT helps implementing the idea that energy is used only mainly when it is needed</p>	<p>Threats: Construction quality is not high enough Building regulations set the goal level of construction Investment is based on minimizing the costs, LCC thinking is not getting forward -> no innovations of energy-efficient solutions Price competition of construction sector Construction industry's resistance to change, and old fashioned operating policies and practices</p>

Table 3. Example: SWOT-analysis for a Finnish Passive House

Conclusions

The pilot projects show that the suggested specifications for the Finnish climate can be met. However, the carried out studies show that there are specific problems initiating from the thick insulation layers especially in the floor structures and floor external wall connections. In the phase of this study, also the building physical performance of the building systems of the pilot houses will be studied.

Even if the awareness of the Passive House concept is rising in northern Europe, there is still a lack of knowledge of what the Passive House concept imply, and also how to design and build them. The dissemination channels should be chosen so that they are followed by the large public: television, magazines, etc. The data must be objective and reliable.

Promotion of the Passive House construction requires updating the national building regulations. The Passive House markets are not born automatically. Energy-labelling the dwellings according to EPBD will have a beneficiary effect, but the level of the national building regulations has the greatest importance. A good economical incentive could be combining the construction permit to the energy-effectiveness of the house by allowing an extended permitted building volume for energy-efficient housing.

Acknowledgements

The paper bases on Intelligent Energy Europe project Promotion of European Passive Houses, Paroc Oy Ab's project Passive Houses for the Nordic and Baltic housing markets, and an IEE project proposal "Promotion of the Passive House Concept to the North European Building Market".

References

- Ståhl, F. (2002). Pre-heating of ventilation air through an earth tube system. Nordic Symposium on Building Physics 2002. [Ståhl 2002]
- Thevenard, D. (2007). Bibliographic Search on the Potential of Earth Tubes. Numerical Logics Inc [Thevenard 2007]
- Nieminen, J., Holopainen, R., Kouhia, I., Saari, M. (2008). Passiivitalo. VTT Tiedotteita. [Nieminen et al. 2008]

New Norwegian Standard for Low Energy and Passive Houses

Inger Andresen and Tor Helge Dokka, SINTEF Building and Infrastructure, NO-7465 Trondheim, Norway
Thor Endre Lexow, Standards Norway, P.O. Box 242, NO-1326 Lysaker, Norway

Introduction

Due to the increased interest in low energy and passive houses in Norway, a project has been initiated to prepare the ground for a Norwegian standard for such houses. The work is led by the official standardization body of Norway, Standards Norway, and is carried out in cooperation with SINTEF Building and Infrastructure. The project is financially supported by the Norwegian State Housing bank and Enova. This paper presents the preliminary recommendations for the content of this standard with respect to passive houses.

Analysis

Because of differences in climate, market situation, construction methods, and indoor comfort requirements, it may not be advisable to have the same passive house requirements in Norway as the ones in Germany and Austria. Also, both Sweden and Finland have proposed preliminary definitions for the passive house standard in their countries that deviate from the German requirements.

In [Dokka and Andresen 2006] it was shown that for the coldest climates in Norway, it is not possible to meet the German passive house heating load requirements with current available technologies. Even for the typical climate of Oslo, it is difficult to meet German passive house requirement considering the current market situation.

Preliminary calculations of annual heating demand and peak heat load were carried out to study the effect of different climates for different building types in Norway. Four different dwelling types were studied, and they were placed in 4 different Norwegian climates (see table 1). All dwelling types were based on real building projects in Norway that have had an ambition to meet the passive house standard; a small and a large detached house, a row house building and an apartment block (see figure 1). For the calculations, all of the buildings are oriented with the main facade facing west, in order to not overestimate the solar gains. Table 2 shows the corresponding areas for the different buildings. When developing the new standard for passive houses, the requirements in the building code and existing standard for calculating the energy performance of buildings (NS 3031:2007) was used as a starting point. Table 3 shows the starting values that were set for the different building types.

	Oslo	Stavanger	Lillehammer	Karasjok
Yearly mean ambient temperature, °C	5.7	7.4	3.3	-2.5
Design winter temperature, °C	-17.6	-8.1	-25.0	-43.4
Annual mean horizontal solar radiation, W/m ²	112	87	106	79

Table 1. The 4 different climates used in the calculations.



Figure 1. Illustrations of building types used in preliminary analysis. Left: Small and large detached dwellings (similar form). Middle: 2 storey row house with 5 apartments. Right: 3 storey apartment block with 14 apartments. Illustrations: Stein Stoknes (left), Aplan Viak (middle) and ABO Architects (right).

	Small detached dwelling	Large detached dwelling	Row house ¹	Apartment block ²
Heated floor area (A_{fl})	160 m ²	200 m ²	547 m ²	1126 m ²
Heated air volume	355 m ³	444 m ³	1231 m ³	2531 m ³
Envelope area (ex windows)	183 m ²	199 m ²	300 m ²	589 m ²
Window and door area ³ (20% of A_{fl}), (S/W/N/E)	32 m ² (3.1/18.1/2.2/8.7)	40 m ² (3.9/22.6/2.7/10.8)	112.5 m ² (0/70/0/42.5)	224 m ² (3/158/4/59)
Roof area	80.5 m ²	100.6 m ²	285 m ²	404 m ²
Floor area (slab on ground)	80.5 m ²	100.6 m ²	285 m ²	404 m ²

¹Areas are for all 5 row house apartments. ²Areas are for the whole apartment building, i.e. for all 14 apartments.

³The window and door area for all the houses are reduced from that in the original designs, down to 20% of the floor area. This is done to be able to reach the passive house standard with reasonable technical solutions.

Table 2. Areas for the different building types.

Ventilation air change rate ¹	1.2 m ³ /m ² h (for detached dwelling and row house) 1.7 m ³ /m ² h (for apartment building)
Temperature gain over fans ²	0.6 °C (0.37 x SFP)
Minimum indoor air temperature set point	20 °C (mean value)
Internal heat loads ³	For yearly energy calculations: 4 W/m ² For power calculations: 3 W/m ²
Air leakage number, N_{50}	0.6 ACH (Infiltration 0.04 ACH)
Exterior walls, main façade	U = 0.10 W/m ² K (~400 mm insulation)
Exterior walls, gable	U = 0.10 W/m ² K (~400 mm insulation)
Roof	U = 0.10 W/m ² K (~400 mm insulation)
Slab on ground	U = 0.10 W/m ² K (~300 mm insulation)
Windows and doors	U = 0.85 W/m ² K (g = 0.46)
Efficiency of heat exchanger	75%
Thermal bridge value, normalised per floor area	0.015 W/m ² K

¹ Ventilation air change rate is given as the expected mean air change rate in the heating season, and not the design air change rate. Values correspond requirements in NS 3031.

² Supply air fan is placed before the heat exchanger; exhaust air fan is placed after heat exchanger. Values correspond to requirements in NS 3031

³ Values correspond to recommended values in [Dokka and Andresen 2006], and are similar to those used in the preliminary Swedish passive house requirements. NS 3031 specifies a value for internal loads of 6.8 W/m².

Table 3. Starting values for building parameters.

Annual heating energy demand and peak heating load were calculated using the dynamic simulation program SCIAQ Pro [Dokka 2005]. The results in table 4 show that it is only for the mildest climate (Stavanger) that the passive house requirement of 15 kWh/m²/yr are met for three of the building types. For the small detached dwelling, the passive house requirements are not met for any of the climates. Note that the heating requirements for the apartment block are higher than for the row house. This is due to the higher ventilation air volume requirements for apartment blocks (as required in NS 3031).

	Oslo		Stavanger		Lillehammer		Karasjok	
	Energy demand kWh/m ² /yr	Power demand W/m ²	Energy demand kWh/m ² /yr	Power demand W/m ²	Energy demand kWh/m ² /yr	Power demand W/m ²	Energy demand kWh/m ² /yr	Power demand W/m ²
Small detached dwelling	22.9	16.2	16.0	11.9	30.4	22.3	53.2	29.7
Large detached dwelling	21.7	15.6	15.1	11.4	29.0	21.5	51.1	28.7
Row house	18.5	14.0	12.6	10.2	25.0	19.7	45.0	26.2
Apartment block	21.5	14.5	14.2	10.6	28.0	20.8	50.1	27.2

Table 4. Calculated energy and power demand for the 4 dwelling types in the 4 different climates.

Figure 2 shows a graphic presentation of the annual heating energy demand as a function of yearly mean ambient temperature. The figure shows that the relationship is almost linear, and can approximately be described by the following equation:

$$Q_{\text{heat}} = 15 + 3.5 \cdot (5 - T_{a, \text{year}})$$

Where Q_{heat} is the yearly heating energy demand in kWh/m²/year and $T_{a, \text{year}}$ is the yearly mean ambient temperature.

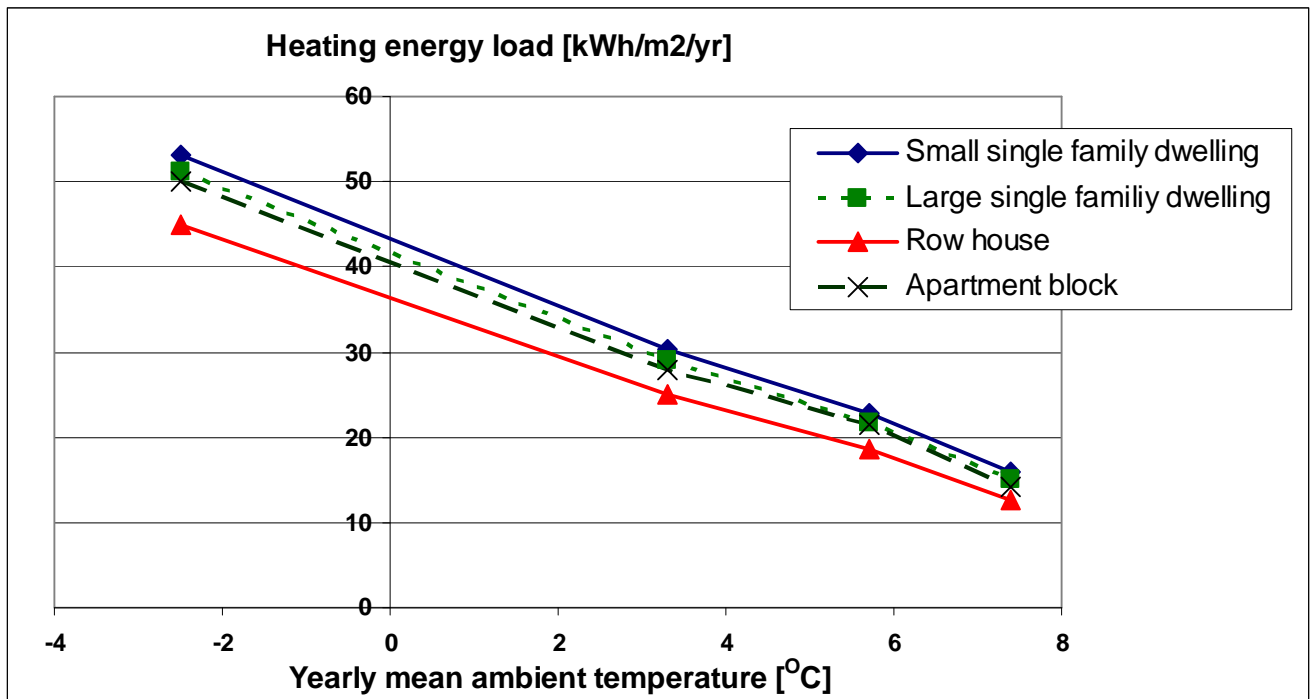

Figure 2. Annual heating energy demand for the 4 different building types as a function of yearly mean ambient temperature.

The next step in the analysis includes finding what construction standard is needed to meet the passive house requirement of 15 kWh/m²/yr for the different housing types in the different climates. Tables 5, 6, 7 and 8 show the results of this analysis. The table shows that it is not possible to reach the 15 kWh/m²/yr requirement for any of the buildings in the coldest climate (Karasjok), given realistic construction standards. Also, for the detached dwellings, it is not possible to reach the passive house standard for the medium cold climate of Lillehammer.

Due to problems with freezing, it is not realistic to reach an efficiency of the heat exchanger above 85% with current available technology. In addition, insulation thicknesses above 550 mm are not likely to be accepted in the market.

Climate	Oslo	Stavanger	Lillehammer	Karasjok
Exterior walls, main facade	U = 0.08 (~450 mm)	U = 0.10 (~400 mm)	U = 0.08 (~450 mm)	U = 0.08 (~450 mm)
Exterior walls, gable	U = 0.08 (~450 mm)	U = 0.10 (~400 mm)	U = 0.08 (~450 mm)	U = 0.08 (~450 mm)
Roof	U = 0.07 (~550 mm)	U = 0.10 (~400 mm)	U = 0.07 (~550 mm)	U = 0.07 (~550 mm)
Slab on ground	U = 0.07 (~450 mm)	U = 0.10 (~300 mm)	U = 0.07 (~450 mm)	U = 0.07 (~450 mm)
Windows and doors	U = 0.8 (g = 0.46)	U = 0.85 (g = 0.46)	U = 0.65 (g = 0.46)	U = 0.65 (g = 0.46)
Efficiency of heat exchanger	85%	79%	85%	85%
Heating energy demand (kWh/m ² /yr)	14.8	14.9	17.1*	33.3*
Power demand (W/m ²)	12.5	11.4	15.9	21.6

Table 5. Calculated building standard of the small detached dwelling that meets the passive house requirement of 15 kWh/m²/yr (* means that the requirement is not met).

Climate	Oslo	Stavanger	Lillehammer	Karasjok
Exterior walls, main facade	U = 0.08 (~450 mm)	U = 0.10 (~400 mm)	U = 0.08 (~450 mm)	U = 0.08 (~450 mm)
Exterior walls, gable	U = 0.08 (~450 mm)	U = 0.10 (~400 mm)	U = 0.08 (~450 mm)	U = 0.08 (~450 mm)
Roof	U = 0.07 (~550 mm)	U = 0.10 (~400 mm)	U = 0.07 (~550 mm)	U = 0.07 (~550 mm)
Slab on ground	U = 0.07 (~450 mm)	U = 0.10 (~300 mm)	U = 0.07 (~450 mm)	U = 0.07 (~450 mm)
Windows and doors	U = 0.8 (g = 0.46)	U = 0.85 (g = 0.46)	U = 0.65 (g = 0.46)	U = 0.65 (g = 0.46)
Efficiency of heat exchanger	82%	75%	85%	85%
Heating energy demand (kWh/m ² /yr)	14.9	15.1	16.1*	31.8*
Power demand (W/m ²)	12.5	12.5	15.4	20.8

Table 6. Calculated building standard of large detached dwelling that meets the passive house requirement of 15 kWh/m²/yr (* means that the requirement is not met).

Climate	Oslo	Stavanger	Lillehammer	Karasjok
Exterior walls, main facade	U = 0.10 (~400 mm)	U = 0.15 (~300 mm)	U = 0.08 (~450 mm)	U = 0.07 (~550 mm)
Exterior walls, gable	U = 0.10 (~400 mm)	U = 0.15 (~300 mm)	U = 0.08 (~450 mm)	U = 0.07 (~500 mm)
Roof	U = 0.07 (~550 mm)	U = 0.14 (~300 mm)	U = 0.07 (~550 mm)	U = 0.07 (~550 mm)
Slab on ground	U = 0.07 (~450 mm)	U = 0.15 (~200 mm)	U = 0.07 (~450 mm)	U = 0.07 (~450 mm)
Windows and doors	U = 0.85 (g = 0.46)	U = 0.82 (g = 0.46)	U = 0.65 (g = 0.46)	U = 0.65 (g = 0.46)
Efficiency of heat exchanger	80%	80%	80%	85%
Heating energy demand (kWh/m ² /yr)	15.0	15.0	15.1	26.4*
Power demand (W/m ²)	12.4	11.2	14.9	18.4

Table 7. Calculated building standard the row house that meets the passive house requirement of 15 kWh/m²/yr (* means that the requirement is not met).

Climate	Oslo	Stavanger	Lillehammer	Karasjok
Exterior walls, main facade	U = 0.10 (~400 mm)	U = 0.15 (~300 mm)	U = 0.08 (~450 mm)	U = 0.07 (~550 mm)
Exterior walls, gable	U = 0.10 (~400 mm)	U = 0.15 (~300 mm)	U = 0.08 (~450 mm)	U = 0.07 (~500 mm)
Roof	U = 0.07 (~550 mm)	U = 0.10 (~400 mm)	U = 0.07 (~550 mm)	U = 0.07 (~550 mm)
Slab on ground	U = 0.07 (~450 mm)	U = 0.10 (~300 mm)	U = 0.07 (~450 mm)	U = 0.07 (~450 mm)
Windows and doors	U = 0.8 (g = 0.46)	U = 0.85 (g = 0.46)	U = 0.65 (g = 0.46)	U = 0.65 (g = 0.46)
Efficiency of heat exchanger	83%	78%	84%	85%
Heating energy demand (kWh/m ² /yr)	14.9	15.0	15.1	29.3*
Power demand (W/m ²)	11.8	10.9	14.7	19.2

Table 8. Calculated building standard of the apartment block that meets the passive house requirement of 15 kWh/m²/yr (* means that the requirement is not met).

Preliminary conclusions and further work

The main requirement in the Norwegian standard for passive houses will most likely be the requirement for maximum energy use for heating. However, the above analysis showed that it is not realistic to have a requirement of 15 kWh/m²/yr in the coldest regions. Based on the linear relationship between annual heating energy demand and mean ambient temperature, the following preliminary recommendation has been proposed:

Type of dwelling	Requirement	
	T _{a, year} ≥ 5°C	T _{a, year} < 5°C
Row houses and apartment buildings	Q _{heat} ≤ 15 kWh/m ² /yr	Q _{heat} ≤ 15 + 3.5 · (5 - T _{a, year})
Detached dwellings above 200 m ² used floor area	Q _{heat} ≤ 15 kWh/m ² /yr	Q _{heat} ≤ 15 + 3.5 · (5 - T _{a, year})
Detached dwellings below 200 m ² used floor area	Q _{heat} ≤ 20 kWh/m ² /yr	Q _{heat} ≤ 15 + 3.5 · (5 - T _{a, year})

Table 9. Proposed requirement for annual heating energy demand (Q_{heat}), for different types of dwellings and yearly mean ambient temperatures (T_{a, year}).

In addition to the requirement on yearly heating energy demand, it has been proposed that the standard should also include the following requirements:

- Maximum CO₂-emissions (kg/m²/year). This measure is probably easier to introduce in the Norwegian market than the concept of primary energy use, since the notion of primary energy is so far not very well known and understood.
- Maximum normalised heat transfer coefficient for transmission, ventilation and infiltration (W/(m²K)). This is to put extra emphasis on well insulated and air-tight envelopes, as well as highly efficient ventilation systems.
- Minimum requirements for components: U-values of exterior walls, roofs, floors, windows and doors, normalised thermal bridge value, efficiency of heat exchanger (certified), specific fan power and air-tightness of the envelope.
- During design, the yearly energy performance should be calculated according to NS 3031, including documentation of input data. Also, the thermal comfort should be calculated using a dynamic method. U-values and thermal bridges should be documented according to relevant ISO/CEN standards.
- As built control: determination of air permeability of buildings by fan pressurization method according to EN 13829, qualitative detection of thermal irregularities in building envelopes by infrared method according to EN 13187, measurement of ventilation air change rate and the efficiency of the heat exchanger installed in the building.

However, the requirements are still under discussion, and will be decided within the framework of the working committee of the project, which in addition to Standards Norway and SINTEF, also include several representatives of the building- and component industry. Moreover, the standard will also be subject to public hearing before its final completion, which is expected in early 2009.

References

- [Dokka and Andresen 2006] Dokka, Tor Helge and I. Andresen, Passive Houses in Cold Norwegian Climate, Paper at the 10th International Passive House Conference, 19-20 May 2006, Hanover, Germany.
- [Dokka 2005] Dokka KA, Dokka TH, SCIAQ Pro – Simulation of Climate and Indoor Air Quality, www.programbyggerne.no, 2005.
- [NS 3031] Norsk Standard NS 3031:2007. Bergning av bygningers energiytelse. Metode og data. Calculation of energy performance of buildings. Method and data. ICS 900.08.21; 91.120.10. Standard Norge, www.standard.no.

A Classification of Passive House for Swedish Conditions

Åsa Wahlström and Svein Ruud, SP Technical Research Institute of Sweden
Martin Erlandsson and Jonas Norrman, IVL Swedish Environmental Research Institute
Eje Sandberg, ATON Teknikkonsult
Maria Wall, Lund University
Hans Eek, Passivhuscentrum Alingsås

1. Abstract

A requirement specification for residential passive houses for Swedish conditions has been developed. The classification sets requirements of supplied power for heating and recommendations of used energy for operational electricity, hot water and heating. This is first version of the definition and it might need a revision after more experiences are reached from built passive houses in Sweden.

2. Introduction

During the last years several good examples of buildings with very low energy use for operation has been realised but the technique has not become mainstream in the building industry. This might be due to that the building proprietor has difficulties to see the technical possibilities for very low energy using buildings and to set high requirements of low energy use when ordering the building from the constructor. In order to tackle these barriers and to speed up the process towards a sustainable built environment the Energy Agency in Sweden gave a mandate to FEBY (Forum for Energy Efficient Buildings) to establish a requirement specification for passive houses. This paper describes the results of the requirement specification settled for residencies.

The definition of Passive house has been developed by considering the corresponding definition in Germany but with adaption to Swedish climate conditions. In order to tackle the Swedish climate properly the requirement specification has two levels, -one for south Sweden and one for north Sweden. The development of the requirement specification is also considering the Building Regulations in Sweden and has therefore the same specifications for climate division of Sweden, specific area etc. Before settling the requirements the specification has been under consideration by national and international expertise within the field.

The aim with the requirement specification is to be used for communication on the building process and for marketing purposes on the Swedish market. It's a requirement specification that is freely to use but in order to avoid misunderstandings for export of Swedish constructions it is recommended to use the definition that is valid in the country considered.

The definition was settled in spring 2007 and thereafter it has been out under consideration by national and international expertise within the field. In autumn 2007 the referred version was corrected by the incoming comments and settled awaiting of experiences from built passive houses in Sweden.

3. Requirement specification of passive houses in Sweden

The requirements of passive house aim to minimize the need of supplied power for heating in buildings for requisite thermal comfort. Supplementary requirements of resource efficiency are set in order to limit the total use of "bought" energy (i.e. for operational electricity, hot water and heating). The requirements of indoor environment should be ambitious and cooling for comfort should not be needed.

Minimum requirements settled in the building regulations (BBR, 2006) are required besides the requirements that is mentioned in the requirement specification.

The requirements are set for A_{temp} that is the floor area in tempered rooms intended to be heated to more than 10°C limited by the inner side of the climate envelope (m^2) (i.e. as in BBR, 2006).

3.1 Requirements of power

Supplied power for the entire building for heating is calculated according to following conditions:

- ❑ a designed indoor temperature of 20°C
- ❑ a designed outdoor temperature for winters (DUT) decided according to Swedish Standard SS 024310 (see Table 1 for DUT_{20} and a time constant of 300 hours).
- ❑ climatic zone south and north are the same as in BBR, 2006
- ❑ at calculations are a maximum value allowed of 4 W/m^2 from internal heat from domestic appliances and persons. Additional heat from the sun should not be included in the calculations.

Supplied power (P_{max}) has the following requirements:

- $P_{\text{max}} = 10 \text{ W}/\text{m}^2$ in climatic zone south.
- $P_{\text{max}} = 14 \text{ W}/\text{m}^2$ in climatic zone north.
- For detached houses with an area of less than 200 m^2 are the requirements, while considering the different climatic zones, according to: $P_{\text{max}200} = P_{\text{max}} + 2 \text{ W}/\text{m}^2$

Note that it is not a requirement to use the supply air system as heat carrier. The requirements refer to the entire the building and not the separate residencies. Calculations of power need are based on calculated heat losses for the building envelope, ventilation and involuntary ventilation, while considering available surplus heat. Airing behaviour is assumed to give negligible losses at the designed outdoor temperature. Calculations of ventilation losses should consider system efficiency and defrosting.

Table 1: Designed outdoor temperature for winters (DUT) decided according to Swedish Standard SS 024310. This standard should be interpreted as at is accepted that the indoor temperature may be decreased with maximum 3°C at extreme outdoor temperatures that appears only ones for 20 years.

City	DUT ₂₀ at a time constant of 300 h °C	T _{outdoor} January °C
Bromma	-10.5	-3.5
Uppsala	-12.8	-4.4
Linköping	-10	-2.9
Kalmar	-7	-1.7
Ronneby	-6.1	-1.5
Göteborg	-8.2	-1.4
Karlstad	-13.1	-4.3
Östersund	-18.2	-8.5
Luleå	-20.6	-10

3.2 Requirements of energy use

Use of energy for the entire building for operational electricity, hot water and heating (i.e. all energy use except for domestic electricity) is calculated according to following conditions:

- A designed indoor temperature of 20 °C.
- Energy calculations for the buildings should be made according to ISO 13790:2004.
- at calculations are a maximum value allowed of 4 W/m² from internal heat from domestic appliances and persons.

Use of energy (E_{\max}) has the following recommendations:

- $E_{\max} \leq 45 \text{ kWh/m}^2$ in climatic zone south.
- $E_{\max} \leq 55 \text{ kWh/m}^2$ in climatic zone north.
- For detached houses with an area of less than 200 m² are the requirements, while considering the different climatic zones, according to: $E_{\max 200} = E_{\max} + 10 \text{ kWh/m}^2$

E_{\max} is supplied energy by district heating, biofuels or electricity while fossil fuels are not alternatives for sustainability and are not allowed within the definition of passive house.

3.2.1 Energy use for yearly use of hot tap water (E_{vv})

A standardized use of hot water is assumed according to:

$$E_{\text{vv}} = V_{\text{vv}} \cdot 55 / A_{\text{temp}} [\text{kWh/m}^2]$$

where the yearly use of hot water (V_{vv} [m³]) are:

$$V_{\text{vv}} = 12 \text{ m}^3/\text{apartment} + 18 \text{ m}^3/\text{person for apartments and}$$

$$V_{\text{vv}} = 16 \text{ m}^3/\text{person for one-family houses and terrace houses.}$$

The person based hot water volume may be reduced with 20% if energy efficient single level tap water devices are used.

The number of persons in each dwelling are assumed to be:

1 room and kitchen = 1 person/apartment

2 rooms and kitchen = 1.5 persons/apartment

3 rooms and kitchen = 2 persons/apartment

4 rooms and kitchen = 3 persons/apartment

5 rooms and kitchen = 3.5 persons/apartment

One-family houses and terrace houses less than 120 m² = 3 persons

One-family houses and terrace houses of more than 120 m² = 4 persons

Note that solar thermal systems are allowed to be placed anywhere of the property belonging to the building. It is allowed to use a distribution calculation if the property has several buildings that shares the same heating system. Domestic appliances with energy class A should be used. Use of domestic electricity should be limited in order to get a low energy use and to avoid over heating.

3.3 Requirements of the building

Air leakages through the building envelope shall be maximum 0,3 l/s m² at +/- 50 Pa, according to SS-EN 13829.

In order to be able to verify the buildings performance the energy use of operational energy and for heating shall be separately measured and entered each month. The used water volume for hot water shall be measured each month and the number of residents shall be entered.

The building shall have a window with an U-value of maximum 0.9 W/(m²K), measured by accredited test laboratory according to SS-EN ISO 12567-1 for a representative window e.g. 12x12 m inclusive frame casement and glass. For additional sizes may calculations be made according to SS-EN ISO 10077-1. The buildings mean U-value for windows and glass partition shall be maximum 0.9 W/(m²K).

3.4 Requirements of indoor environment

Sound from the ventilation system shall be at least sound class B in the bedroom according to SS 025267. The supply air temperature after the additional heating coil shall be maximum 52 °C.

4. Discussion

The definition was settled in 2007 and now needs to collect experiences from built passive houses in Sweden. The definition has requirements of supplied power for heating and recommendations of energy use. With more experiences from built and used passive houses in Sweden the recommendations of used energy should be sharpened with requirements. Further revisions might be needed in order include not only operational electricity connected to heating but also additional operational electricity. Also the definitions of designed outdoor winter temperature might to be improved.

5. Acknowledgement

The authors are grateful for financial support from the Swedish Energy Agency and Västra Götalandsregionen.

6. References

BBR, 2006, Building regulations of the National Board of Housing, Building and Planning, Boverkets byggregler, BFS BFS 1993:57 med ändringar till och med 2006:22.

Jonas Norrman, Martin Erlandsson, Eje Sandberg, Maria Wall, Hans Eek, Svein Ruud, Åsa Wahlström: "Kravspecifikation för passivhus i Sverige –Energieffektiva bostäder", Energimyndighetens program för passivhus och lågenergihus, Version 2007:1, Forum För Energieffektiva Byggnader.

Short presentation from Denmark

Paper missing.

Session 10

Planning and design of passive house projects

Svein H. Ruud, Kristina Mjörnell, Åsa Wahlström SQUARE –A Quality Assurance MANAGEMENT system FOR retrofitting with good indoor ENVIRONMENT and energy efficiency	262
Robert Nøsen, Erling Bakkemo, Åslaug Hennissen Fremtidens hus i dag	269
Helena Bülow-Hübe Analys av förutsättningar och begränsningar vid utformning av skolor, förskolor och äldreboenden som passivhus i Sverige.....	272
Tor Helge Dokka, Kjetil Helland Løvåshagen: Norges første lavblokkprosjekt med passivhusstandard	283

SQUARE –A Quality Assurance MANAGEMENT system FOR retrofitting with good indoor ENVIRONMENT and energy efficiency

M.Sc. Svein H. Ruud, Dr. Kristina Mjörnell and Dr. Åsa Wahlström
SP Technical Research Institute of Sweden
Box 857, SE-501 15 Borås, Sweden
Tel.: +46-105165514
E-Mail: svein.ruud@sp.se

Hans Eek, Passivhuscentrum, 441 81 Alingsås, Sweden

Abstract

A quality assurance (QA) system for good indoor environment and energy efficiency has been developed in Sweden. It has been used only for Swedish conditions. In order to obtain experience and to encourage retrofitting of buildings for good indoor environment and energy efficiency to become more mainstream in Europe, the SQUARE (a System for QUality Assurance when Retrofitting Existing buildings to energy-efficient buildings) project was initiated. Six European countries (Austria, Bulgaria, Finland, the Netherlands, Spain and Sweden) will participate in the project that is supported by the Intelligent Energy Europe programme and will run from November 2007 until April 2010. As a part of the SQUARE project the QA-system will be applied in retrofitting of a social housing in Sweden. It is Alingsåshem in Alingsås that are planning to retrofit 300 apartments. In the first round 18 apartments will be retrofitted with passive house principles. The energy use for heating, heating of tapwater and operation electricity are planned to be reduced from 177 to 65 kWh/m². This paper will discuss the QA-system and how it will be used in the retrofitting down to passive house standard at Brogården in Alingsås.

1 Introduction

In the EU about 1-2 % of the building stock is renovated every year, which often gives cost-effective opportunities for major energy efficiency improvements. However, in order to achieve significant reductions of energy use in existing buildings, it is important to perform future large-scale retrofitting of buildings in a systematic and controlled manner. When retrofitting a building many aspects must be taken into account, such as local resources, costs, building traditions, legislation and financing. These aspects will have an impact on decision-making and on the outcome of the retrofit, which will differ from case to case, and so there are no universal solutions. However, to achieve the intended results of the retrofit requires knowledge, continuity and communication that can be assured by a dynamic and flexible quality assurance (QA) system that describes a systematic and controlled way of working.

1.1 Previous experiences with a QA system

One example of a quality assurance system is a Swedish QA system for indoor environment that was developed about ten years ago, and has since then been successfully applied to multifamily houses/social housing, schools, kindergartens and offices (Samuelson, 2000). The clients are very satisfied with the QA system of indoor environment which has been confirmed by two investigations with questionnaires and interviews of clients about experiences and satisfaction with the QA system (Emami and Forseaus, 2004; Cedås and Hilmarsson, 2006).

New emphasis on energy conservation (such as in the European Energy Performance in Buildings Directive [EPBD, 2002/91/EC]), has added new demands for energy improvements as well. However, a reduction of energy use is appropriate only if it does not adversely affect the indoor environment. In order to avoid an

unbalanced concentration on either good indoor environment or energy efficiency that might result in mutually adverse effects, the building sector requested that the QA system should be extended to consider energy use as well. Consultants, specialist researchers, property-owners, builders and building managers have therefore jointly developed the QA system with the objective of including energy efficiency assurance (Wahlström and Ekstrand-Tobin, 2005). The system has been extended to a labelling system for the total building performance of both indoor environment and energy use and covers the planning, design, construction, commissioning and operation phases. It includes methods and routines to control the indoor environment and energy use by using occupant questionnaires, the building monitoring systems or other methods during operation. A third party certifies the energy and indoor environment and makes annual inspections.

The primary objective of the QA system is to work towards continuing improvements and encourage property managers, administrators and occupants to carry out improvements that otherwise would not have been considered. The QA system aims to be flexible so that it can be used for different building categories, different organisational structures and different parts of the building process. In order to obtain a first relatively quick evaluation of the extended system, it was applied to buildings which formed a special case in that their indoor environments had already been certified with the QA system. They therefore needed only the additional element of QA of their energy systems and consequently the evaluation considers only the operation phase. The pilot projects were therefore chosen to be a school building, an office and an area of multi-family houses.

The results show that the QA system is really flexible (Wahlström et al. 2006 and 2007). For each pilot project it was possible to introduce quantified and measurable goals, action plans for measures and management systems during operation with authorities, responsibilities and awareness for all actors within the process. All pilot projects have already shown, with their new targets and action plans for work, that they are moving towards improved energy performance. The projects have also led to a significant improvement in the systematic work related to the controlling energy use, while at the same time maintaining a good indoor environment.

1.2 Retrofitting of residential buildings

Good management of a building can typically reduce energy use by 5 - 25 % as, for example, shown in pilot projects for the QA-system. A retrofit of a building provides significant opportunities for introducing cost-effective measures for major reduction of operational energy, often between 30 -70 %. In order to achieve high targets of energy efficiency in buildings, it is not enough to introduce a QA-system first in the operational phase. It is important to refine and apply the QA-system during the complete retrofit of a building (the planning, design, construction and commissioning phase).

Since an important part of the energy efficiency improvement potential lies in residential building stock, the use of the QA system for retrofit improvements is justified as follows:

- there are several million residential buildings in the European Union
- many of these buildings were built before the oil crises of the 1970s, and therefore use unnecessarily high amounts of energy
- the need to make up for many years of neglected maintenance means that both the building envelope and building services need to be upgraded, which provides the owners with an opportunity for cost-effective energy measures
- since social housing stocks consist of many similar apartments, the measures can easily be replicated cost-effectively.

The QA system is flexible in terms of organisation, requirements and end energy-efficient solutions by concentrating more on a systematic way of working. Even though many aspects must be taken into account in different European countries, such as local resources, costs, building traditions, legislation and financing, it should be possible to develop a QA-system adopted to each country's conditions. The QA-system is now ready to be applied in retrofitting of multi-family buildings in different European countries.

2 Description of the quality assurance system

The primary objective of the system is to work towards continuing improvements and to encourage clients, builders, architects, administrators and occupants to apply improvements that otherwise would not have been considered. This requires quantified and measurable goals, action plans for measures and management systems during operation.

Cooperation between all parties, from scientists and public authorities to designers, contractors, managers and users, is important for the end results. All need to listen to, and to learn from, each other. Good indoor environment and efficient use of energy can be achieved by creativity, planning and layout design, choice of materials, general designs and detailed and overall designs of systems for heating, ventilation, electricity and water supply. This QA scheme makes sure that the requirements set out in legislation, standards or common codes of practice are fulfilled as intended. An independent third party supervises, evaluates and checks that the requirements are fulfilled. Measurements show that the performance requirements have been met. Occupants' perceptions of the indoor environment are evaluated with the help of questionnaires, while energy use is evaluated with energy measurements or energy bills. The QA system includes new building and rebuilding work, as well as improvements of existing buildings, and covers the entire process, from planning and design, through the construction stage to final use and operation. Certification is based on ISO 9000 procedures and is described in (SPCR 114E, 2007). To ensure that the system's rules are accepted, and that they are needed by the building sector, the system has been approved by a committee consisting of representatives of private and municipality property owners.

2.1 The retrofitting phase

Certification work for existing buildings that are to be retrofitted begins with a TPI (Thorough Primary Inspection) of the indoor environment and a first energy analysis (FEA). The TPI and FEA consist of an survey of the property, with its actual status, aspects and performance of indoor environment and energy use (Wahlström, 2005). This can be done by examining construction drawings, operational follow-up programs, control systems or other documentation; visual inspections, interviews with staff and occupants, as well as additional measurements. The evaluation of the performance of indoor environment is primarily based on inquiries to users while energy use is based on actual measurements. The procedures are illustrated in Figure 1.

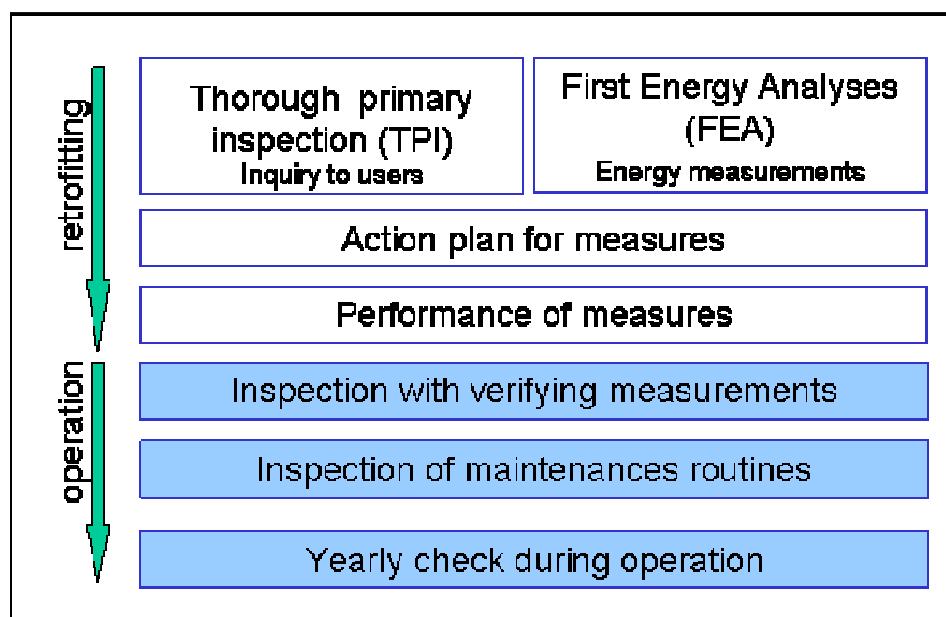

Fig. 1 - Illustration of procedures for quality assurance of indoor environment and energy use

The results of the TPI and FEA are then used to set objectives to be achieved, including a performance measurement specification of how the comprehensive targets should be measured and checked. The QA scheme considers the fact that each building project is unique, and therefore the annual energy use target will be set on the basis of the building's current condition and its associated limitations, rather than on the basis of a specific predefined figure. Limitations of energy use targets are related to building use, climate and existing design of the building. Targets for indoor environment are at least the same as set in legislation or authority recommendations, but may be stronger by request of the building client. Targets for indoor environment consider the parameters; thermal comfort, air quality, ventilation, moisture safety, acoustic conditions, airtightness, light and tap water quality.

The next step is to draw up an action plan for measures and carry them out in order to reach the set targets. Measures for reducing cold bridges and increasing airtightness are crucial for both indoor environment and energy use. It is also important to ensure that the building services work together with the building envelope in a complete energy system. The third party makes brief inspections, measurements and evaluations of the measures regularly during the complete retrofit, including advice and discussions. When the retrofit is complete, the building system is adjusted until the planned building performance is researched.

2.2 The operation phase

Experience shows that successful energy efficiency in a building will be maintained only if the building is efficiently managed, operated and maintained, with all parties steadily improving their performance and with the results regularly monitored. This means that the energy target must be regularly monitored and reviewed, and the QA system is therefore based on a management system modelled on a Swedish standard (SS 62 77 50, 2003). The standard includes comprehensive routines for energy management for any organisation, and has therefore been refined and customised to fit the building sector.

Clear and easily understood operating and care instructions for the premises are a prerequisite for continued good indoor environment and energy performance. The various documents need to be matched to the needs of the target personnel concerned: for example, to the building operator's staff, to cleaners and/or to occupants and users. There are instructions for cleaning, and instructions for the heating and ventilating systems which provide details of such aspects as the maximum number of persons with which the systems can deal and so on.

Routines for monthly and yearly monitoring and evaluation of energy performance with stated actions in response to deviations from the set targets will assure continued energy efficiency. Indoor environment parameters are measured at the end of the retrofitting process and are followed up by measurements in 20 % of the apartments every year, so that all the apartments have been monitored over a five-year period.

3 The SQUARE project

In Sweden, about a million apartments were built between 1964 and 1974 in order to tackle the country's housing shortage. Due to moderate rents, these apartments are mainly occupied by low-income families and may be considered social housing. These buildings are now due for renovation of the building envelope, as well as retrofitting of building services systems. As a result, an important part of the energy efficiency potential lies in the social housing stock.

The QA system of both indoor environment and energy use is now ready to be applied in retrofitting of social housing in Sweden. However, the QA system has been developed in Sweden and has been used only for Swedish conditions. In order to obtain experience and to encourage retrofitting of buildings for good indoor environment and energy efficiency to become more mainstream in Europe, the SQUARE project was initiated.

The SQUARE (a System for QUality Assurance when Retrofitting Existing buildings to energy-efficient buildings) project aims to assure energy-efficient retrofitting of social housing with good indoor environment in a systematic and controlled way. Six European countries (Austria, Bulgaria, Finland, the Netherlands, Spain and Sweden) will participate in the project. The project is supported by the Intelligent Energy Europe programme and is planned to start in November 2007 and will run for 30 months.

Each country has a unique stock of social housing with different needs of renovation. The QA system, which is unique of its kind, could be adopted by other countries to suit their particular conditions since it is flexible in terms of organisation, requirements and end energy-efficient solutions by concentrating primarily on a systematic way of working. The Swedish QA system will be a very good base for other countries to start out from to develop their own versions adapted to their conditions, such as regulations, building traditions and climate. Within the project, the developed QA systems will be tested in pilot buildings, which is also intended to provide good examples for inspiring social housing owners to carry through energy-efficient retrofitting projects. An overview of the work packages in the project is given in Figure 2.

One example of the developments of the QA system is to introduce interviews with each actor before they are contracted in order to check their motivation for the projects goals and working procedures. This will be one further guarantee for a successful project and the core target.

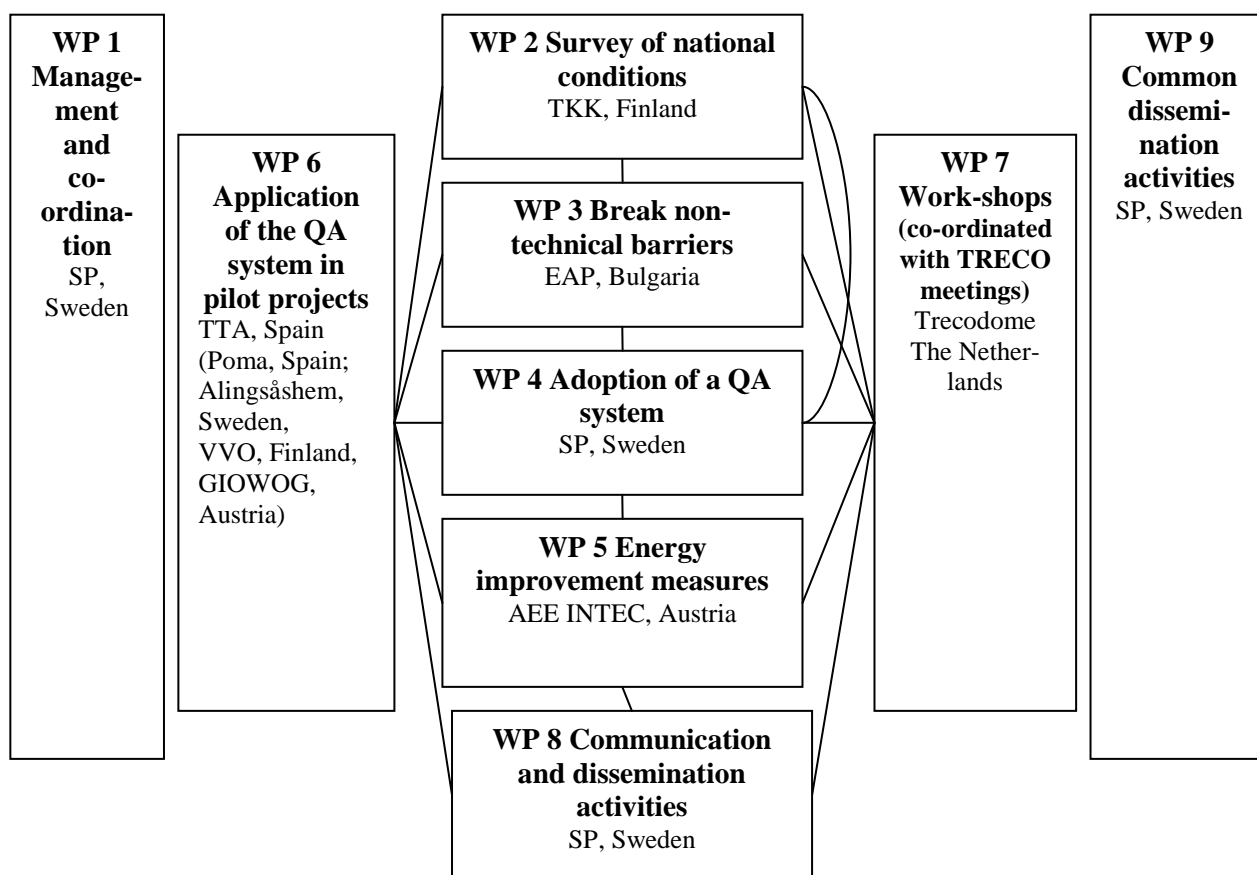

Fig. 2 – A flow chart with an overview of the work programme for the SQUARE project

3.1 Objectives of the SQUARE project

The SQUARE project aims to promote energy-efficient retrofitting with improved indoor environment in social housing by using the QA system adopted for each country with their quite different climatic and sociological conditions. An important task is to use the QA system in pilot projects in order to spread information and the methodology in European countries through practical experience and good examples.

In order to obtain a wider understanding and spread of knowledge of the system, it is important that the Swedish standard (SS 62 77 50, 2003) should be harmonised at a European level (i.e. become a CEN standard) as well as being developed, extended and aligned to the building sector. The project will therefore prepare rules for a future European energy management standard for the building sector that will be passed on to CEN.

The QA system will also be a good example of how future labelling of buildings can be performed. The final results are important for those who buy or rent properties. It means a lot to know that the building to be occupied has been built or renovated and is operated to ensure a healthy indoor environment with minimum use of energy.

3.2 Description of the Swedish pilot project at Brogården in Alingsås

Brogården is a social housing area consisting of 300 apartments. It was built in 1970. There were about 1 million similar apartments built in Sweden during the period 1963 to 1973. Alingsåshem is here intending to retrofit the buildings to passive house standard. This will be achieved by:

- Thorough insulation of the building envelope
- Additional air-tightening the building envelope
- Changing to super-insulated windows
- Installing high efficient air-to-air heat recovery

The traditional heating system consisting of hydronic radiators will be substituted with small hydronic reheaters, one in each apartment. They will only be activated at very low outdoor temperatures. In the summertime tap water will be heated by solar panels. In the wintertime the tap water will be heated by district heating, as will the reheaters. The goal is to reduce the energy consumption from 216 kWh/m² to 92 kWh/m² (including household electricity). This means energy consumption well below the values set for new building in the Swedish building code.

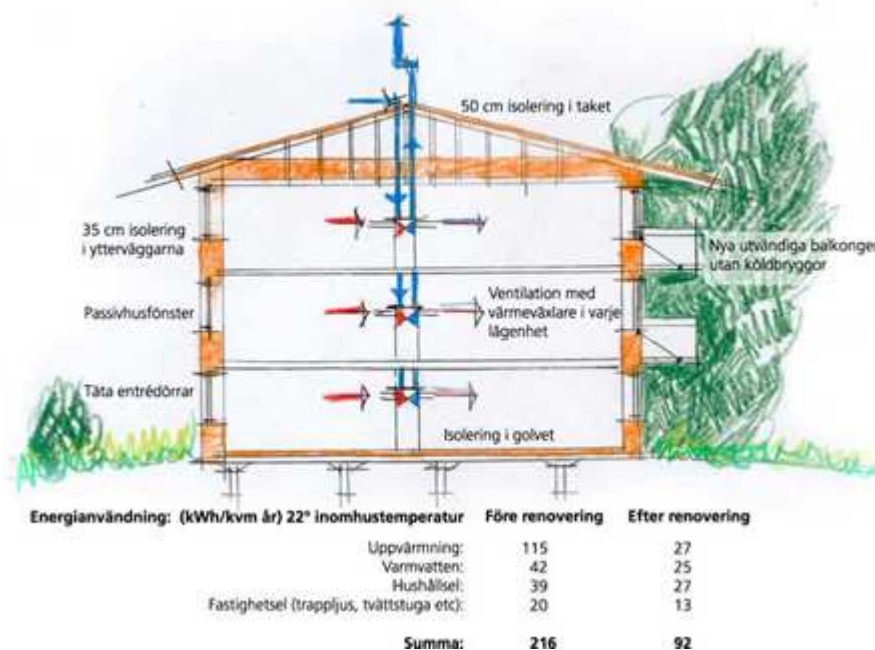

Fig. 3 – Sketch of the Brogården retrofit

4 References

- Cedås D., Hilmarsson E.**, (2006), P-marking, Mapping the significance of P-marking in the building process. Examination work in Engineering in Building Technology, Högskolan i Borås, Ingenjörshögskolan, No. 9/2006. In Swedish.
- Emami K., Forseaus A.**, (2004), Questionnaire in compulsory schools. Comparison of P-marked and non P-marked schools. Högskolan i Borås, Ingenjörshögskolan. In Swedish.
- EPBD**, (2002), Directive 2002/91/EC of the 16 December 2002, The European Community Official Journal, no. L 001, 04/01/2003 p. 0065-0071.
- Samuelson I.**, (2000), Quality assurance of the indoor environment in schools, offices and dwellings through P-marking, Proceedings of Healthy Buildings 2000, Espoo, Finland, August 6-10.
- SPCR 114E**, (2007), Certification rules for P-marking of the indoor environment and energy use, SP Technical Research Institute of Sweden.
- SS 627750**, (2003), Swedish Standard for Energy Management - Requirement Specification. SIS Swedish Standard Institute.
- Wahlström Å.**, (2005), P-marked indoor environment and energy use -Handbook before certification of energy use, SP Rapport 2005: 41, ISBN 91-85303-73-9, Energiteknik, Borås, In Swedish.
- Wahlström Å., Ekstrand-Tobin A.**, (2005), Quality assurance of indoor environment and energy use. Proceeding of the 7th Symposium on Building Physics in the Nordic Countries, page 1041- 1048, Reykjavik, June 13-15.
- Wahlström Å., Törnström T., Ruud S.**, (2006) A Quality Assurance System for Indoor Environment and Energy Use, Proceeding of EPIC 2006 AIVC, Lyon, France, 20-22 November.
- Wahlström Å., Nielsen JR., Ruud S., Törnström T.**, (2007), A voluntary scheme for certification of indoor environment and energy use, Proceedings of CLIMA 2007, WellBeing Indoors, paper B01: 1235, Helsinki, Finland, 10-14 June.

Fremtidens hus i dag

Robert Nøsen og Erling Bakkemo, Structura AS, Vilhelm Kragstveit 6, 7023 Trondheim
Åslaug Hennissen, Leiv Eiriksson Nyskaping as, Pb 1262 Pirsenteret, 7462 Trondheim



Kulsås Amfi ved Granåsen skisenter i Trondheim kommune.

Nytt boligkonsept fra Structura

Structura og Leiv Eiriksson Nyskaping viser kommuner at det er realistisk med høye ambisjoner. Sammen går vi ut med informasjon til kommunene med framlegging av et kostnadseffektivt kvalitetskonsept for passivhus. Den enkelte kommune får tilbud om å tilpasse kvalitetskonseptet for sin kommune.

Structura bygger fremtidens boliger i dag, med fokus på energisparing, ressurs og avfallsminimering, trivsel, sosialkomfort og samfunnsansvar. Structura bygger samfunnsøkonomisk lurt og lønnsomt. Målet til Structura er å bygge miljøvennlige bygg med lang levetid, og minimalt behov for vedlikehold. Structura beviser at det finnes utbyggere som er villige til å ta ekstra kostnader for å oppnå dette. Structura bygger bygg som har arkitektonisk spennende utseende, og hvor brukervennlighet står i fokus.

Kulsås Amfi – prisbelønnet forbildeprosjekt

Trondheim kommunes Energisparepris 2007 ble tildelt Structura AS for arbeidet med prosjektet Kulsås Amfi. Med sin byggemåte fremstår Kulsås Amfi som et av de beste bygg i Norge, hva gjelder energibehov.



Structura mottok Trondheim kommunes Energisparepris 2007 for forbildeprosjektet Kulsås Amfi.

Tilført energibehov er beregnet til kun 84 KWh/m²/ år. Dette er hele 40 % under de nye energikravene som blir gjeldende i Norge fra august 2009. Hadde alle husstander i Trøndelag redusert energibehovet tilsvarende, ville det ha tilsvart forbruket av energi i Melhus kommune i ti år framover. Med betong i alle vegger, balansert ventilasjon og 3-lags glass i vinduer vil en leilighet på Kulsås Amfi oppleves nærmest lydett for støy utenfra.

Ekstra tiltak i forhold til standard bolig

Kulsås Amfi er bygd med mange ekstra energitiltak i forhold til en standard bolig. Bygget har tykkere isolasjon i gulv, tak og vegger: 35cm i gulv, 40cm i tak og 30cm i vegger. Hele bygningskroppen er oppført i isolert betong med en konstruksjon som tilnærmet eliminerer kuldebroer og ivaretar et lavt energiforbruk. Alle yttervegger består av BeWi Byggesystem som har en kjerne av betong med 16cm EPS (ekspandert polystyren skum) utvendig og 8cm innvendig. Dette tilsvarer 30cm mineralull i en ordinær trekonstruksjon. Tak/terrasser er isolert med 40cm isopor og tekket med membran under kraftige impregnerte terrassebord.

Alle oppgitte data for isolasjon av tak, yttervegger, gulv og vinduer er bedre enn Statens Bygningstekniske etats siste oppgraderte Byggeforskrifter.

Bedre isolerte vinduer: Vinduer og terrassedører er av meget høy kvalitet og isolasjonsevne i vedlikeholdsfri PVC med 3-lags energiglass med U-verdien 1,0 W/m²K

Varmepumpe basert på bergvarme driver felles varmtvannsberedere. Dette reduserer behovet for tilført energi med 16 %. Fornybar energi produserer varmt tappevann i et felles storbereder system med oppvarming fra varmpumpe basert på bergvarme som hovedenergikilde, med elektrisitet som tilskuddsvarme.



Kulsås Amfi er bygd med flere ekstra energitiltak.

Kulsås Amfi er bygget for å kunne stå i 20 – 30 år uten nevneverdig vedlikehold:

- Konstruksjon består av betong og ekstrudert isolasjon (ingen fukt og råtefare).
- Fasader pusset med gjennomfarget puss.
- Royal linolje impregnert trevirke i fasader, rekkverk og blomsterkasser (evigvarende).
- Pvc vinduer (foreløpig beregnet levetid 40 år).

Kostnadseffektivt kvalitetskonsept for kommunale boliger

Structura har videreutviklet sitt unike boligkonsept fra Kulsås Amfi til å møte samfunnets behov for kostnadseffektive kvalitetsboliger til innbyggere som ikke klarer å skaffe seg bolig eller beholde tilfredsstillende bolig. Structura synliggjør for kommuner at det er samfunnsøkonomisk riktig å bygge boliger med høy kvalitet i alle ledd, helt fram til ferdigstillelse og innflytting. Structura bygger allianse mot 8 kommuner i Trondheimsregionen for å høyne ambisjonsnivået til kommunene og de arbeider for at 2-3 kommuner i 2008 innfører mål om passivhus i sin virksomhet. Det langsiktige målet for Structura er å bygge et passivhusprosjekt i en av kommunene.

Norske kommuner med ambisjoner

I arbeidet med kommunene i Trondheimsregionen har Structura kartlagt kommuner i Norge som har høye ambisjoner for redusert energibehov i kommunale bygg.

Kristiansand kommune har en visjon om bare å benytte fornybar energi og at utslippet av klimagasser ligger på et bærekraftig nivå. Målet er at stasjonært energiforbruk er stabilisert på 2004 - nivå innen 2010. Og at

klimagassutslippet er redusert til 1990 - nivå innen 2010, og til 75 % av 1990 - nivå i 2025. For kommunale bygg skal blant annet lønnsomme enøktiltak gjennomføres. Det betyr at kommunen senker lønnsomhetskrav til energieffektiverende tiltak. Nye kommunale bygg bygges som lavenergibygg med fleksibel oppvarming. Dette gjelder også ved totalrenovering. Nye kommunale bygg baseres på fornybar energi der fjernvarme ikke tilbys, og oljekjeler i kommunale bygg erstattes med kjeler basert på fornybar energi eller fjernvarme [Kristiansand kommune 2006].

Bystyret i Stavanger kommune uttalte i møte 31.10.2005 at de ser svært positivt på utbygging av såkalte "grønne bygg" (lavenergi boliger). Videre uttalte bystyret at det er ønskelig at det stilles krav om at minst 10 % av boligene som bygges i Stavanger skal være lavenergi boliger. Blant annet kan dette legges inn som krav i reguleringsplaner. Bystyret ønsker også at miljøhensyn skal vektlegges ved rehabilitering av offentlige bygg. I 2008 er Stavanger et utstillingsvindu for fremtidens lavenergi boliger med flere forbildeprosjekter. To av byggeprosjektene i Norwegian Wood har mål om å nå passivhusstandarden (65 kWh/kvm/år). Nye feltutbygginger med lavenergi boliger under planlegging. Lavenergi boliger i ferd med å bli standard. Når Stavanger kommune bygger nye boliger, bygger de lavenergi boliger med ekstra isolering og mindre behov for oppvarming [Stavanger kommune 2005].

Fredrikstad kommune har også satt mål om redusert energibehov og reduserte utslipp. Klimagassutslippet pr. innbygger fratrukket industriens direkte utslipp skal ned mot 3,0 tonn pr. innbygger pr. år innen 2010. Andel fornybar energi skal komme over 50 % fra 2008. Kommunens byggmasse skal i snitt redusere sitt forbruk fra 178 kWh/m²/år til 158 kWh/m²/år innen 2010 [Fredrikstad kommune 2007].

Bergen Tomteselskap forlangte bygging av passivhus ved salg av et boligområde. Høsten 2007 gjennomførte Bergen tomteselskap utbyggerkonkurranser for to felt i Øvre Sædal i Fana på henholdsvis 50 boenheter og 5 boenheter. En tredjedel av bebyggelsen skal være passivhus, mens resten skal bygges som lavenergi boliger. Vinnere var Gravidal prosjektutvikling AS i samarbeid med Morten Grindaker og M3 Arkitekter AS med 50 boenheter og NexiBygg AS i samarbeid med Link Signatur med 5 boenheter [Bergen tomteselskap 2008].

Passivhus er målet i arbeidet med kommuner i Trondheimsregionen

Passivhus er Structuras mål i arbeidet med kommunene i Trondheimsregionen. Dette fordi passivhus er enda mindre energikrevende enn lavenergi boliger.

I passivhus elimineres varmetapet samtidig som man optimaliserer bruken av frie energibærere og gjenvinning av varme. Lønnsomheten måles i framtidige besparelser av kjøpt energi i forhold til investeringskostnaden. Merknaden lønner seg pga. den store besparelsen til energi. Komforten er også bedre i et passivhus enn i en vanlig bolig. Lyder utenfra blir isolert bort (ideelt mot trafikkstøy). I soverom vil dårlig luft hele tida bli skiftet ut av ventilasjonsanlegget (astma og allergi vennlig). Passivhus har et energitilførsels behov på 65 kWh/år/kvm². Gjennomsnitt i norske leilighetsbygg i 2005 hadde et forbruk på 210 kWh/år/kvm².



Alle snakker om været, Structura gjør noe med det.

Referanseliste:

- [Kristiansand kommune 2006] Kristiansand kommune, Klima- og energiplan for Kristiansand, s. 3-4 (2006)
- [Stavanger kommune 2005] Stavanger kommune, Klimaplan for siddiser, s. 13 (2005)
- [Fredrikstad kommune 2007] Fredrikstad kommune, Klima- og energiplan 2007 for Fredrikstad kommune, s. 36-37 (2007)
- [Bergen tomteselskap 2008] Bergen Tomteselskap, <http://www.bts.no> (2008)

Analys av förutsättningar och begränsningar vid utformning av skolor, förskolor och äldreboenden som passivhus i Sverige

Helena Bülow-Hübe, Tekn Dr
Byggprojektering, Tyréns AB, 205 19 Malmö
Tel +46 40 698 16 83, Helena.bulow-hube@tyrens.se

Abstract

Denna artikel belyser några problem och möjligheter för att utforma byggnader som förskolor, skolor eller äldreboenden som passivhus. Artikeln tar sin utgångspunkt i tre praktikfall som projekterats under hösten 2006-hösten 2007, samtliga med ambitionen att klara passivhuskriterierna. Det första är förskolan Stadsskogen i Alingsås, det andra är äldreboendet Bokliden i Mörap, Helsingborgs kommun, och det tredje är Flexibla huset i Annestad, en byggnad i Malmö Stad som byggs för att enkelt kunna skifta verksamhet från förskola till skola och/eller äldreboende. Samtliga hus har utformats med en klimatskärm som motsvarar andra passivhusprojekt i Sverige men det har ändå visat sig svårt att klara effektkraven för passivhus. Alla hus är under uppförande men i olika skeden. Stadsskogen är i det närmaste klar, medan flexibla huset just har påbörjats. Det finns därför ingen erfarenhet från driften ännu, utan endast från simuleringar från projekteringsskedet.

Utformningen av de tre projekten är likartad. Alla är mer eller mindre uppförda som enplanshus, med liknande utformning av ytterväggar, tak och grund. Byggnaderna grundläggs med betongpatta på mark, medan resten av stommen har förhållandevis liten värmetröghet. Ingen byggnad klarar ett effektbehov på 10 W/m², utan ligger mellan 12-24 W/m² med rätt stor osäkerhet i varje värde. Ventilationsflödena är dock avsevärt större än för bostäder. Värmedistributionen är olika i samtliga hus, Stadsskogen värms med luft, Bokliden värms delvis med luft och resterande tas med en liten radiator i varje lägenhet medan Flexibla huset får golvvärme.

Analyserna i artikeln visar att det är svårt att klara passivhuskraven för dessa typer av verksamheter då de utformas som långsmala enplanshus med ljusinsläpp från två håll. Med två eller flera våningar skapas bättre förutsättningar eftersom transmissionsförlusterna per golvyta minskar. Samtidigt utformas förskolor nästan undantagslös som enplanshus, eftersom man vill undvika fallrisker i trappor. För förskolor är därför möjligheterna till renodlade passivhus enligt gällande passivhuskriterier små, medan skolor och äldreboenden möjligen lättare kan utformas med en lämpligare geometri.

Bakgrund

De första passivhusen i Sverige är en grupp med 20 radhuslägenheter i Lindås. De inflyttades 2002 och har utvärderats noggrant, bl a av SP och LTH [Ruud & Lundin, 2004; Wall, 2006]. Utvecklingen av passivhus har efter en liten trevande inledning följts av allt fler realiserade projekt. Energimyndigheten finansierar t ex ett doktorandprojekt för uppföljning av ett antal demonstrationsprojekt för passivhus: Nybyggnad av hyreslägenheter i Värnamo och Frillesås, nybyggnad av enfamiljshus i Lidköping, samt ombyggnad av flerbostadshus från miljonprogrammet i Alingsås. Erfarenheter från projektens uppförande har nyligen presenterats i en lic-avhandling [Jansson, 2008]. Passivhusen har fått mycket uppmärksamhet i Sverige, men utvecklingen har främst tagit fart i västra och mellersta Götaland. Betoningen på bostäder har också varit mycket stark, se redovisning på www.energieffektivbyggnader.se. Av fem genomförda projekt är alla bostäder. Av de 15 pågående byggprojekt som nämns är alla utom 3 st bostadsprojekt. Två av dessa tre beskrivs i denna artikel. Även passivhuscentrum [passivhuscentrum.se] redovisar pågående och genomförda passivhusprojekt, här nämns 20 stycken projekt varav 18 st är bostäder.

Om inledningen var bostäder börjar vi nu se en andra våg av pionjärprojekt inom verksamheter som förskolor, skolor och äldreboenden. Utformning av hus för dessa verksamheter ställer dock delvis helt andra krav på vä-

sentliga funktioner, bland annat luftflöden, belysning, akustik, brandfrågor och tillgänglighet, vilket kan få konsekvenser för husens energianvändning och i förlängningen på om de kan få kallas passivhus. I jämförelse med Tyskland är projekterade luftflöden för skolor och förskolor i Sverige avsevärt större, kanske dubbelt så stora. I skolor och förskolor varierar dessutom internlasterna och luftmängderna kraftigt under dygnet. Höglastfallet inträffar under dagtid då även solstrålning finns att tillgå. Natttid är verksamheten stängd och internlasten är nära noll, vilket leder till kraftigt ökade värmeeffektbehov. Samtidigt är fläktar ofta avstängda under natten för att spara energi. Vid luftvärme innebär detta samtidigt att all värmeförsörjning stängs av, vilket skapar särskilda problem som måste hanteras i projekteringen. Geometrin är dessutom ofta ogynnsam, eftersom förskolor vanligen byggs som enplanshus. Detta beror på att man vill undvika fallrisker i trappor för de små barnen och för att få god markkontakt. Ett annat önskemål som brukar väga tungt är att få in dagsljus från två håll, vilket ofta leder till relativt smala huskroppar.

Den definition som hittills tagits fram för passivhus i Sverige avser bostäder. Det viktigaste kriteriet i definitionen gäller den maximalt avgivna värmeeffekten per kvadratmeter uppvärmd yta och den har angetts till max 10 W/m² för Södra Sverige [Forum för energieffektiva byggnader, 2007]. Implicit är kravet ställt så att det skall vara möjligt att värma husen med luft, utan att använda återluft eller att öka luftflödena utöver de hygieniska riktvärdena. Denna artikel vill belysa några problem med att klara effektkraven enligt den gällande svenska passivhusdefinitionen som författaren upplevt vid projekteringen av 3 st projekt. Därefter görs en enkel analys av möjligheterna att klara effektkraven utifrån en helt stationär betraktelse av effektbehovet för värme.

Kortfattad beskrivning av projekten

Förskolan Stadsskogen i Alingsås

Allmän beskrivning

Det kommunala förvaltningsbolaget i Alingsås, FABS AB genom Guido Hjorthemer står som beställare för Sveriges första förskola byggd enligt passivhusprincipen. Egentligen är det Barn- och ungdomsförvaltningen i Alingsås kommun som vågat sig på att beställa en passivhusförskola. Förskolan skall hysa 90 barn fördelat på 5 avdelningar och uppförs i den nya stadsdelen Stadsskogen. Förskolan är på 937 m² och innehåller förutom de 5 avdelningarna ett mottagningskök och mindre personalutrymmen. Inflyttning är planerad till omkring den 1 maj 2008. Projekteringen genomfördes under hösten 2006 medan spaden sattes i jorden under våren 2007.

Byggnaden har en planform som ett T och är huvudsakligen uppförd i ett plan. Sidovingarna och mittskeppet har pulpettak. Då taklutningen är längs mittskeppets längdriktning skapas utrymme för en mindre övervåning där personalutrymmen och fläktrum placerats. Sidovingarna utförs som full-isolerade byggnader, sammanlänkande till mittskeppet med uppvärmda vindfång. Varje avdelning har entré via kallt vindfång, se Figur 1. Huset projekterades dock inte för att bli ett passivhus utan detta beslut kom ganska sent in i projekteringen. Det är möjligt att huset hade fått en annan form om passivhuskravet hade varit med från början [Hallberg, 2008].



Figur 1 (t v) Förskolan Stadsskogen ritad av Glantz arkitektstudio genom Maria Hallberg. Vy av energiberäkningsmodell för del av byggnad (en avdelning) från Derob-LTH (t h).

Klimatskal och täthet

Huset projekterades med följande U-värden i klimatskalet: väggar utförs med U-värde $0,1 \text{ W/m}^2\text{K}$, tak med $0,09$, golv i medeltal ca $0,11$ och fönster med U-värde på $1,0 \text{ W/m}^2\text{K}$ (för hela fönstret inkl karm och båge). Den genomsnittliga värmegenomgångskoefficienten för klimatskalet, U_m är $0,17 \text{ W/m}^2\text{K}$. Alla detaljer har antagits kunna utformas i stort sett utan köldbryggor. Fönsterytan utgör ca 20% av golvytan för en avdelning (127 m^2). Täthetskravet sattes till $0,25 \text{ l/s m}^2$ omslutande yta vid $\pm 50 \text{ Pa}$ tryckskillnad. Uppföljning genom tryckprovning har utförts och denna visar att kravet i princip har innehållits, då en otäthet på $0,26 \text{ l/s m}^2$ är det som uppmätts.

Rumshöjden varierar invändigt mellan $2,7 \text{ m}$ och $3,95 \text{ m}$, se Figur 2. Detta mått är dock endast upp till undertaket. De isolerade ytterväggarna är $3,1 \text{ m}$ i låga änden och $4,9 \text{ m}$ i den höga. Den varierande rumshöjden beror på pulpettak som är uppbyggt av takbalkar med mellanliggande isolering. Den omslutande ytan mot ute i förhållande till uppvärmd yta (A_{om}/A_{temp}) blir därmed ganska stor, ca $3,4$. På detta sätt får man även ett byggsystem som är relativt enkelt att få lufttätt, samtidigt som installationerna kan dras innanför klimatskärmen och akustikkraven kan lösas med hjälp av nedpendlade undertak. Den lägsta rumshöjden $2,7$ meter kommer från BBRs krav för rumshöjd enligt kap 3:11: "I undervisningslokaler och andra lokaler avsedda för ett större antal personer skall rumshöjden vara minst $2,70$ meter" [BBR 12].

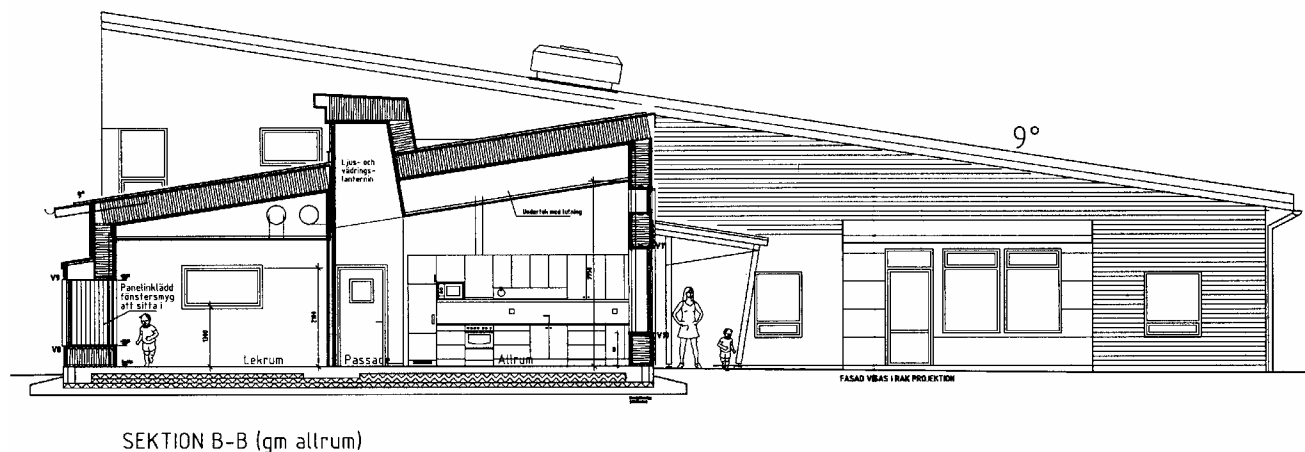

Figur 2 Sektion genom sidovinge vid taklanternin samt fasad av huvudskeppet.

Uppvärmning och ventilation

Ventilationsflödet för en avdelning är projekterat till 220 l/s eller $1,73 \text{ l/s m}^2$ i tilluft resp 230 l/s eller $1,81 \text{ l/s m}^2$ i frånluft. Detta är nära 5 ggr högre än BBRs minimikrav på $0,35 \text{ l/s, m}^2$. Flödet är dimensionerat efter personbelastningen och motsvarar ca 10 l/s, person . Förskolan får ett centralt luftbehandlingsaggregat med värmeåtervinning med roterande växlare med en antagen temperaturverkningsgrad på minst 80%. Uppvärmning sker med hjälp av tilluften. För att spara energi är det vanligt att fläktarna stängs av helt under natten då verksamheten inte är igång. Om huset är luftvärmigt innebär en sådan lösning att även värmesystemet stängs av. Under projekteringen diskuterades därför frågan hur värmebehovet kan föras fram nattetid. Intermittent drift alternativt återluft diskuterades, och det gjordes även studier av hur mycket temperaturen skulle hinna sjunka om fläktarna stängdes under hela natten. Som lösning väljs troligen intermittent drift, men aggregatet är förberett för återluft.

Huset simulerades i Derob-LTH genom att bygga modeller av huset avdelningsvis. Eftersom innertaket följer yttertaketets form gjordes en modell som precis följer husets form, se Figur 1. I simuleringen räknas luftflödet om till en luftomsättning med hänsyn till den ventilerade volymen som i modellen är 555 m^3 . (Obs, nyttovolymen är ca $127 \times 2,7 = 343 \text{ m}^3$). I simuleringarna antogs vidare att flödet nattetid kunde reduceras till 25% av dagflödet. Då temperaturverkningsgraden för ventilationen är 80%, kan ventilationsförlusterna överslagsmässigt beräknas som 20% av det styrda flödet plus det antagna läckageflödet pga infiltration/exfiltration som antagits till $0,05 \text{ oms/h}$. Dagtid är de specifika transmissionsförlusterna något större än ventilationsförlusterna, medan de nattetid är dominerande, då flödet reduceras, allt stängs helt, se nedan:

Transmissionsförluster: $P_t = \text{Summa } UA = 74 \text{ W/K}$.
 Ventilationsförluster: $P_v = 0,33 \cdot 0,34 \cdot 555 = 62 \text{ W/K dagtid}$
 $P_v = 0,33 \cdot 0,12 \cdot 555 = 22 \text{ W/K nattetid}$

En uppskattning av internlasternas storlek och variation under dygnet gjordes utifrån förväntad personbelastning, belysning om max 10 W/m² och vissa övriga laster, se figur 3 för en avdelning. Nattetid sattes internlasten till nära noll (0,8 W/m²). Maxvärdet är 20 W/m², varav hälften antas komma från belysningen. Under sommaren antas belysningen vara delvis släckt, vilket ger en något lägre interlast.

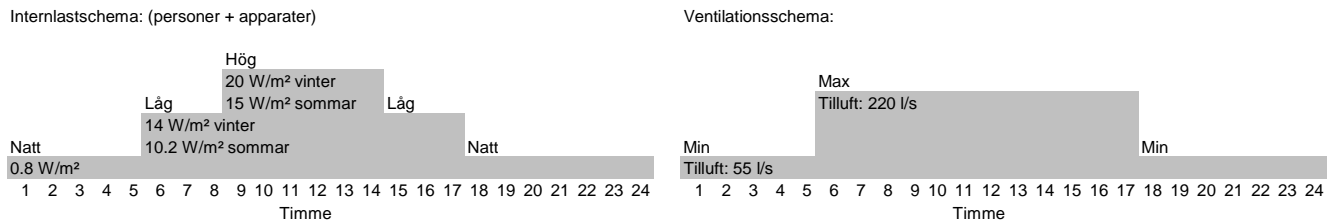

Figur 3 Antaget schema för internlast och ventilation för en avdelning i Stadsskogen.

Derob användes även för att studera inomhustemperaturer, energibehov för uppvärmning samt inblåsningstemperaturer. Energi användningen för rumsuppvärmning beräknades till ca 36-38 kWh/m²år för en förskoleavdelning på 127 m² vid en önskad inomhustemperatur om 22°C. Varmvatten, driftel och verksamhetsel tillkommer. Det största värmeeffektbehovet för en avdelning vid normal användning hamnar på ca 24 W/m² för 22°C inne resp 17 W/m² om ventilationen stängs av helt. Maxeffekten inträffar på natten för en utetemperatur på -16° (klimatfil för Göteborg). En sänkning av innetemperaturen till 20 °C sänker effektbehovet i storleksordningen av drygt 1 W/m². Med denna utformning når man således inte den traditionella definitionen av ett passivhus där det maximala behovet av tillförd värme anges till 10 W/m² (för 20°C inne). Orsakerna är dels den höga rums höjden, vilket ger en stor uppvärmd volym i förhållande till golvarean, dels att internlasterna är så ojämnt fördelade och nästan obefintliga nattetid då man inte heller har solstrålning att tillgå. Eftersom man dagtid har betydligt högre ventilationsflöde än för en bostad visade studierna att luftflödet dagtid var fullt tillräckligt för att värma även en tom lokal (utan internlast) under en kall vinterperiod.

Situationen under nattetid var dock mer oroande och specialstuderades därför. Om flödet nattetid reduceras till 55 l/s (25% av dagflödet) och inblåsningstemperaturen samtidigt skall begränsas till 52°C (enligt passivhusdefinitionen) blev den största värmeeffekt som kunde tillföras nattetid ca 2,3 kW eller 18 W/m². Med denna maxeffekt införd i simuleringen kan dock lufttemperaturen i lokalen sjunka från önskat 22°C till strax under 20 grader på morgonen, vilket dock kunde accepteras eftersom det rörde sig om mycket få timmar. Om ett 25%-igt flöde är svårt att realisera i praktiken kan intermittert drift under riktigt kalla perioder vara ett alternativ. Det valda min. flödet är något högre än BBRs krav på 0,35 l/s, m² (motsvarar 44 l/s). Går man ända ner till 44 l/s kan man med 52-gradig luft inte för fram mer än ca 1,8 kW eller 14 W/m² och temperaturerna kommer då att sjunka ännu mer under natten. Detta fall har dock inte beräknats.

Äldreboendet Bokliden i Helsingborg

Allmän beskrivning

I Helsingborgs kommun genomförs just nu en tillbyggnad av ett befintligt äldreboende i Mörarp, ett mindre samhälle utanför Helsingborgs Stad. Bokliden innehåller idag 31 st bostäder för äldre. Det är en väl fungerande anläggning med samlingsrum, kök, personalrum, konferensrum m.m. Den behöver dock utökas. Den nya delen kommer att innehålla 13 st lägenheter om 35 kvm vardera, plus gemensamma ytor såsom matsal, vardagsrum och servicefunktioner som mindre tvätt- och städutrymmen samt fläktrum. Tillbyggnaden är en ganska låg T-formad vinge i ett plan med en total yta om 670 m² BRA och utförs i passivhusteknik. Inflyttning är planerad till oktober 2008. Kärnfastigheter genom Bengt O Andersson är beställare.

Klimatskal och täthet

Huset projekterades med följande U-värden i klimatskalet: väggar utförs med U-värde 0,11 W/m²K, tak med 0,07, golv i medeltal ca 0,10. Fönstren har U-värde 0,9 W/m²K (för hela fönstret inkl karm och båge), utom för ett par mindre brandklassade fönster, där U-värdet endast är ca 1,8 W/m²K. I genomsnitt är U_m ca 0,14 W/m²K. Fönsterytan utgör ca 14 % av golvytan. Denna byggnad är avsevärt lägre än de andra två, rumshöjden är i genomsnitt ca 2,65 m. Detta märks också på A_{om}/A_{temp} som är lägst av de tre exemplen, ca 2,5. Täthetskravet har satts till 0,25 l/s m² vid +/- 50 Pa. Under täthetsarbetena kommer huset att provtryckas i omgångar, sektionsvis. Den sektionsvisa provtryckningen görs för att kunna gå fram med produktionen på ett rationellare sätt.

Tillbyggnaden uppförs med en trästomme av sammansatta träreglar (samverkansreglar) för att minska köldbryggorna och låglutande takbalkar av limträ (Kerto-balkar). Ett annat viktigt skäl att välja denna stomlösning var också att få en lufttät klimatskärm som var relativt byggvänlig, med få genomföringar av plastfolien. Genom att klimatskärmen och innertaket följer takbalkarnas lutning skapar man också ett litet installationsutrymme i korridortaket, där ventilationskanalerna förläggs, se Figur 4. Plastfolien placeras indraget i både väggar och tak.

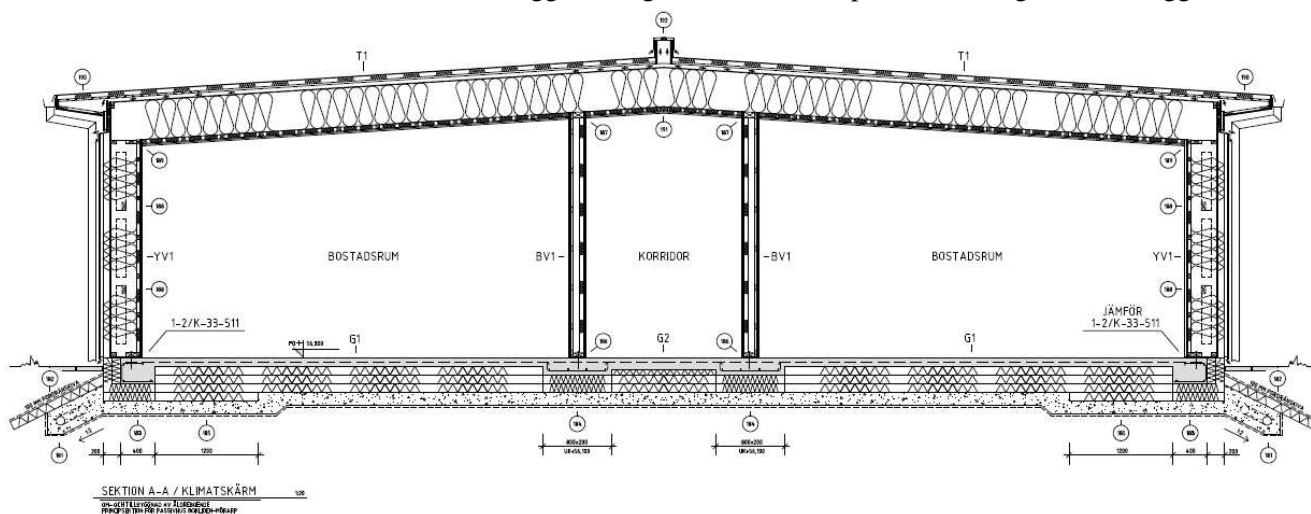

Figur 4 Huvudsektion genom byggnadens klimatskal. (K: Paragon AB gm Lars-Owe Nygårdh).

Uppvärmning och ventilation

Varmvatten och värme kommer att produceras i den befintliga anläggningen, där energikällan är naturgas. Fjärrvärme finns inte att tillgå. Anläggningen kommer också att kompletteras med solfångare, som beräknas ge 45 – 50 % av energibehovet per år för varmvatten för hela anläggningen. Ventilationen i den nya delen utförs med ett nytt centralt FTX-aggregat med kapacitet 500 l/s. Återvinningen sker med roterande värmeväxlare, återvinningsgrad ca 81 %. I tilluftskanalen placeras ett vattenburet värmebatteri. Ventilationen styrs så att den ger 0,74 l/s, m² och ca 0,37 l/s m² nattetid eller drygt dubbla BBR kravet dagtid. (motsvarar 20 l/s och lägenhet dagtid och 10 l/s, lgh nattetid). På grund av högre och individuella temperaturkrav i de olika lägenheterna och temporära krav på högre luftomsättning kommer en liten vattenburen radiator att installeras i varje lägenhet.

Effektbehoven beräknades i Derob-LTH för en internlast som varierade mellan 2,9 på natten, 4,3 W/m² på dagen till som mest 11 W/m² på kvällen, i snitt 6,2 W/m². Hörnlägenhetens maxeffektbehov blev då 15,5 W/m² vid 20°C och 18,9 W/m² vid 23°C som är den önskade innetemperaturen vintertid. För mittlägenheten minskar effektbehovet till ca 11,9 W/m² vid 20°C och till 14,5 W/m² vid 23°C inne. Om internlasten sänks kvällstid till i snitt 4 W/m², påverkas inte maxeffekten, eftersom denna inträffar på natten då internlasten är oförändrat låg. Däremot ökar energibehovet för uppvärmning med 30 %. Nyare beräkningar för hela tillbyggnaden tyder på att internlasterna kan bli högre än uppskattat, upp mot 8 W/m² i snitt [Brunbäck & Teinvall, 2008].

Övriga funktionskrav som påverkat utformningen

Eftersom ett vårdboende ställer krav på att varje lägenhet skall utföras som en egen brandcell, innebär detta vissa saker för ventilationslösningen. Eftersom ventilationsbehovet för varje lägenhet är så litet valdes ett centralt fläktaggregat. För att förhindra brandspridning mellan lägenheter vill man dock kunna stänga av ventilatio-

nen rumsvis. Lösningen blev att vid varje lägenhet sätta ett brandspjäll på tilluftskanalen och ett på frånluftskanalen med en gemensam spjällmotor. Vidare blir varje rum delvis en egen klimatzon inom byggnaden, och för att åstadkomma en individuell reglering skulle det krävas värmebatterier i tilluftskanalen vid varje lägenhet. Detta bedömdes som en alltför dyr lösning. Istället valde man att sätta en liten radiator (vattenburet system) i varje lägenhet för att klara kravet på individuell reglering.

Brandkraven medförde att ett par mindre fönster fick utföras med brandklassning. Brandklassning införs t ex när två fönster i vinkel tillhörande två olika brandceller hamnar för nära varandra. Att U-värdet blir så mycket sämre beror enligt glastillverkarna på att det inte finns några 3-glasfönster som är brandklassade, utan man är då hänvisad till en 2-glaslösning, vilket ger sämre U-värden. Hade arkitekten varit mer uppmärksam på detta från början, hade man troligen kunnat undvika brandklassning genom att ändra fönsterplaceringen.

Akustikkraven, särskilt vad gäller stegljudsöverföring mellan lägenheter, ställde särskilda krav på utformningen av lägenhetsskiljande väggar och speciellt på utformningen av betongplattan under väggarna. I princip finns två lösningar: (1) Efter härdning av betongplattan sågas en slits genom plattan där väggen skall stå. Även den översta av isolerskivorna under plattan skall slitsas. (2) En bred och kraftig vot av betong gjuts under väggen. Lösning 1 innebär att man bryter igenom det lufttäta skikt mot marken som betongen normalt utgör. Detta måste därför eftertätas, t ex med en gummilist. Risken för radoninträning från mark borde dessutom öka avsevärt, eftersom det kan vara svårt att få en sådan slits helt gastät. Vidare måste man se till att inga rör gjuts in i betongen där den skall slitsas. Lösning 2 innebär en dyrare lösning och framför allt en betydligt längre uttorkningstid för betongen. I det aktuella projektet valdes att slitsa betongplattan under lägenhetsskiljande (icke-bärande) väggar, medan väggen mot korridorer utfördes med kraftig vot. Eftersom väggen mot korridor även är bärande fanns det ett annat skäl att gjuta en kraftigare sula här.

Förskolan Synålen, Flexibla huset, i Malmö

Allmän beskrivning

Utanför Bunkeflo, i den snabbt växande stadsdelen Annestad har Stadsfastigheter i Malmö Stad påbörjat byggandet av en förskola i Kv Synålen. Beställarombud är Mikaela Peetre Malthé. Byggnaden är projekterad med flexibilitet som huvudtema, tillsammans med idéer på att göra det till ett passivhus: Flexibiliteten består i att byggnaden relativt enkelt ska kunna byta funktion och även kunna fungera som skola med fyra klassrum eller äldreboende med 10 lägenheter. Som förskola kommer byggnaden att ha ca 70 barn fördelade på fyra avdelningar. Förskolan har även gemensamt lekrum, mottagningskök och personalutrymmen. Ytan är 851 m² BRA.

Klimatskal och täthet

Huset projekterades med följande U-värden i klimatskalet: väggar utförs med U-värde 0,11 W/m²K, tak med 0,09, golv i medeltal ca 0,09. Fönstren beräknas i genomsnitt ha U-värde 0,95 W/m²K (för hela fönstret). I genomsnitt är U_m ca 0,16 W/m²K. Fönsterytan utgör ca 17 % av golvytan. Den omslutande ytan mot ute i förhållande till uppvärmd yta (A_{om}/A_{temp}) är ca 2,9. Täthetskravet är satt till 0,25 l/s m² vid +/- 50 Pa.

Klimatskalet består av en träregelstomme med fasadbeklädnad av tegel och skivor. Byggnaden är utformad som två stycken ”tåglängor” som binds samman av ett något smalare samlingsrum /lekrum, se Figur 5. Huset projekterades först utifrån en huvudidé om att utnyttja enbart takbalkar för bärning och isolering för att ventilationskanalerna skall kunna dras fram i varmt utrymme och för att de i framtiden enkelt skall kunna ändras utan att gå igenom det lufttäta skiktet. Under programskedet hade huset två motstående pulpettak, men under systemhandlingskedet förändrades det till formen av ett traditionellt sadeltak. Efter systemhandlingsfasen gjordes en byggkostnads kalkyl och i detta skede försökte man pruta bort takbalkarna mot en traditionell fackverkstakstol, främst för att mellanväggarna blev för höga och därmed dyra. Men man hade då inte hela konsekvensbilden klar för sig vad gällde de speciella täthetskraven i detta projekt, samt önskan om att förlägga kanaler varmt och minimera antalet genomföringar i tätskiktet. En fackverkstakstol ger inte samma förutsättningar. För att få tillbaka kanalerna innanför klimatskärmen utvecklades därför en hybridlösning av takstolarna. Norra halvan av huset får fackverkstakstol medan den södra halvan (som påverkas mest vid byte av verksamhet) får takbalkar.

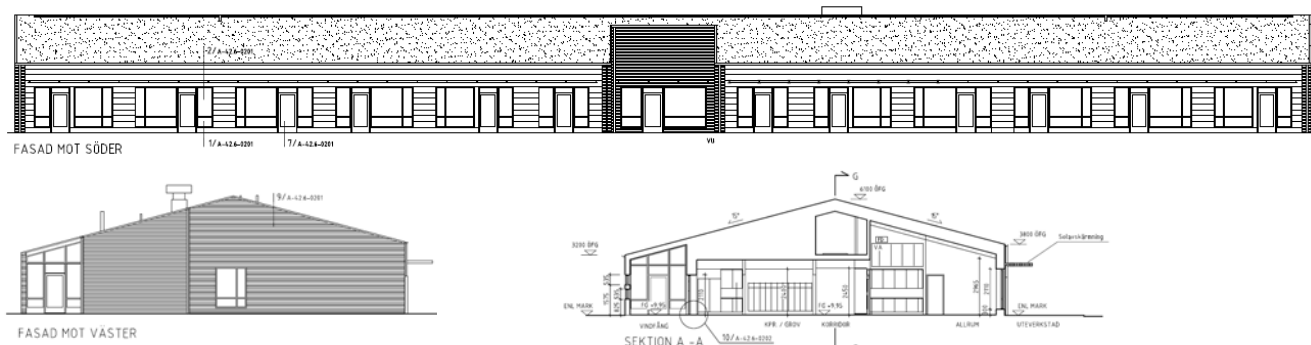

Figur 5 Flexibla huset ritat av White arkitekter genom Charlotte Kristensson och Ola Dellson.

Uppvärmning och ventilation

Huset förses med ett centralt luftbehandlingsaggregat med roterande värmeväxlare med ca 80 % verkningsgrad. Ventilationsflödet för hela byggnaden kan kapacitetsregleras i tre steg och är projekterat för 1050 l/s i grundflöde (1,23 l/s m²) samt 1760 l/s (2,07 l/s m²) i maxflöde i förskolefallet. Fläktarna stängs nattetid, vilket i medeltal beräknas ge ett uteluftsflöde om 500 l/s eller 0,50 l/s m². Skolfallet beräknas ge ungefär samma ventilationsbehov. I äldreboendefallet skulle flödena bli lägre, grundflöde ca 800 l/s och maxflöde ca 1100 l/s, dock i snitt ca 850 l/s (1,0 l/s m²) pga nattdrift. Detta är högre än för Bokliden, och förklaras till stor del av att lägenheterna projekterades för betydligt högre flöde, 30 l/s, trots att lägenheterna har samma funktion och storlek.

Under systemhandlingsfasen var huset projekterat för luftvärme med ett par zoner med decentraliserade värmebatterier. Detta prutas bort efter den första kalkylen och istället valdes en vattenburen golvvärmelösning trots oro för att detta är svårreglerat. Huset ligger i ett område som saknar fjärrvärme, och kommer istället att anslutas till naturgas. Effekten av solavskärmning, fönsterytor och olika verksamheter för energi- och inneklimatfrågor studerades i systemhandlingsskedet i Derob-LTH. Dessa studier tydde på maxeffektbehov upp mot 19-20 W/m². Efter bygghandlingsskedet beräknades energianvändningen för förskolefallet med VIP+ till 69 kWh/m² varav 36 till uppvärmning, 25 till tappvarmvatten, 8 kWh/m² till fastighetsel (fläktar och pumpar). Därutöver tillkommer verksamhetsel. Internlasten varierade då mellan 0 på natten och helger, 6,6 fm och em samt 12.8 W/m² mitt på dagen. I snitt under en vecka blev internlasten 3,5 W/m². Effektbehovet beräknades inte i denna fas.

Övriga funktionskrav som påverkat utformningen

Under systemhandlingsskedet redovisades planlösning och principiell utformning och förläggning av installationssystem för samtliga tre verksamheter förskola, skola och äldreboende. Under bygghandlingsskedet projekterades byggnaden som en förskola, men ganska långtgående förberedelser har gjorts för att kunna byta verksamhet, främst till äldreboende vilket är den största förändringen både rumsmässigt och installationsmässigt. Saker som hanterats under projekteringen berör t ex i viss mån förläggning av brandcellsgränser men framför allt handlar det om installationer och akustikkraV. Bland annat har avloppskanalernas läge under golv valts med avseende på framtida badrumsplaceringar och även att kunna skapa fall i framtida duschplattor i äldreboendefallet har förberetts. Vad gäller akustikkraVen för ljudöverföring mellan lägenheter har man gått så långt att man gjuter kraftiga voter under alla de väggar som kan komma att bli lägenhetsskiljande. Slitsade lösningar har undvikits, vilket hade varit svårt med ingjutna golvvärmeledningar.

Statisk värmeeffektanalys för generiskt hus

Det allra viktigaste kriteriet för ett passivhus brukar anges som värmeeffektbehovet. Detta beror på att idén med passivhuset ju är att det skall vara möjligt att värma huset med luft, med ordinarie luftflöde. Effektbehovet för ett passivhus skall för bostäder inte uppgå till mer än 10 W/m² för södra Sverige och 14 W/m² för norra [Forum för energieffektiva byggnader, 2007]. KraVen säger vidare att en internlast om 4 W/m² får tillgodoräknas vid bestämning av effektbehovet, men ej solstrålning. Vidare får en dimensionerande vinterutetemperatur (DVUT) för en byggnad med en tidskonstant på 300 h väljas. Kan man med dessa kriterier konstruera en förskola eller

skola som passivhus? Förskolor byggs vanligen som enplansbyggnader för att skapa god tillgänglighet för små barn. För skolor är det vanligare att se byggnader uppförda i flera plan än ett.

Genom att göra en enkel transmissions- och ventilationsförlustberäkning och därefter göra en statisk effektanalys kan värmeeffektbehovet beräknas för olika geometriska utformningar av klimatskärmen. Jag har här valt att titta på inverkan av den geometriska formen, fönsterandelen och U-värdet hos fönstret. Den isolerade byggnadskroppen utformades mycket enkelt, som en skokartong. Då man väljer att fördela ytan på ett plan blir naturligtvis förlusterna från huset större än om man väljer att utforma det som ett tvåplanshus. Om vi utgår från en uppvärmd yta på 1000 m², dvs i samma storleksordning som de två redovisade förskolorna ovan, och väljer en rumsbredd på 12 meter blir huset drygt 83 meter långt om det utförs i ett plan. För ett tvåplanshus blir det istället hälften så långt, se Figur 6. Vägghöjd hos klimatskärmen väljs till 2,7 meter. Detta ger att A_{om}/A_{temp} blir 2,5 för enplanshuset och 1,6 för tvåplanshuset. Hade rumshöjden varit 4 meter (snittet för Stadsskogen) hade A_{om}/A_{temp} blivit 2,8 för enplanshuset resp 1,9 för tvåplanshuset.

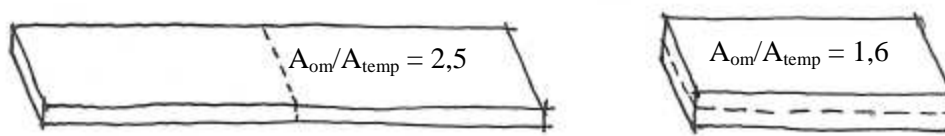

Figur 6 Principiell volymstudie av ett hus på 1000 m² med bredd 12 m fördelad på ett resp två plan.

Två fönsterandelar studeras, 15% resp 25%. Den mindre fönsterandelen kan betraktas som en form av nedre gränsvärde med hänsyn till dagsljusstillgång i lokalen medan 25% får anses högt med hänsyn till risken för övertemperaturer. U-värdet på fönstret varierades mellan 0,7 W/m²K (som är kravet för passivhus i Tyskland) och 0,9 W/m²K som är bland det bästa som hittills har gått att få för svenska fönster. Det som skiljer mellan dessa fönster är främst isoleringen av karmdelen, medan glasdelen i bägge fall ofta håller ungefär samma U-värde. Väggen gavs ett U-värde på 0,1, tak fick 0,09, platta på mark fick 0,11 resp 0,09 (yttre och inre randzon) och dörrar gavs U-värdet 1,0 W/m²K. Köldbryggor på omkring 15% lades schablonmässigt till; 50 W/K för enplanshuset och 40 W/K för tvåplanshuset. Trots fönstrens utveckling mot lägre U-värden är det fortfarande dessa som kraftigt dominerar transmissionsförlusterna. Detta framgår tydligt i Figur 7 där ytfördelningen resp fördelningen av transmissionsförlusterna jämförs för tvåplanshuset med 25% fönsterandel och U-värde 0,7 på fönstren. Trots det låga U-värdet utgör transmissionsförlusterna genom fönstren ca hälften av alla förluster, även om deras ytandel bara uppgår till 15% klimatskalets yta. De specifika transmissionsförlusterna och deras fördelning för alla kombinationer framgår av Figur 8.

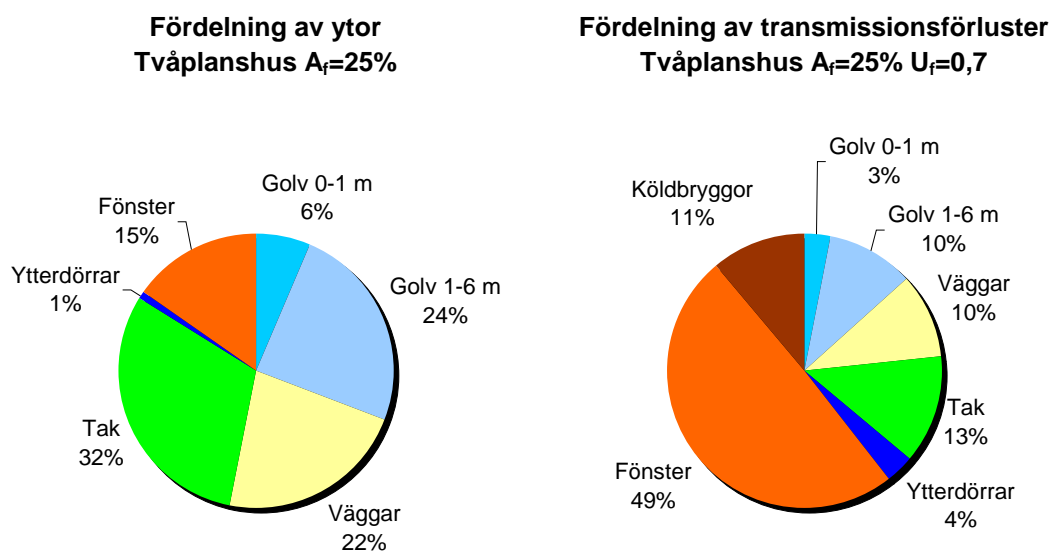

Figur 7 Procentuell fördelning av ytor för tvåplanshuset med 25% fönsterandel samt fördelning av transmissionsförluster för samma hus med U-värde 0,7 W/m²K för fönstren.

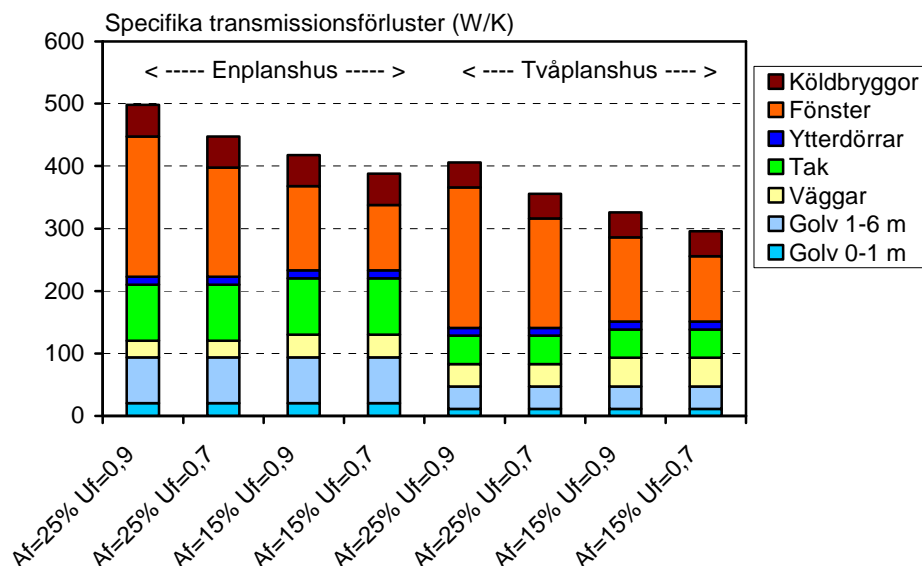

Figur 8 Specifika transmissionsförluster för de olika kombinationerna av fönsterytor och U-värden.

Ventilationsförlusterna beräknades för BBRs minflöde om 0,35 l/s, med en verkningsgrad om 80% plus ett läckageflöde om 0,05 oms/h. De specifika ventilationsförlusterna blir då 102 W/K och är lika för alla fall. Värmeeffektbehovet för huset beräknas rent stationärt, utan hänsyn till värmelagring, för en innetemperatur på 20°C. Därefter görs ett avdrag för interna laster på 4 W/m². Resultaten visas i Figur 9. Ur diagrammen kan man avläsa vilken fönsterandel som kan accepteras utifrån en given dimensionerande utetemperatur, byggnadsform och U-värde för fönster, U_{f} . Här kan man se att det är omöjligt att uppfylla passivhuskraven för en enplansbyggnad med U-värde 0,9 på fönstren. Med U-värde 0,7 klarar man kriteriet på 10 W/m² om fönsterandelen uppgår till max 19% för DVUT -8°C, vilket motsvarar orter som Göteborg, Ronneby och Kalmar. För orter med lägre dimensionerande utetemperatur klarar man inte ett enplanshus i något av de studerade fallen. Tvåplanshuset är mera gynnsamt, och man kan klara passivhuskriteriet för södra Sverige för en DVUT så låg som -12°C för U-värde 0,9 på fönstren (fönsterandel max 16%). Byter man till $U_{f}=0,7$ klarar man DVUT -14°C (fönsterandel max ca 17%). För att få tillåta högre effektbehov får man hänvisa till kraven för norra Sverige.

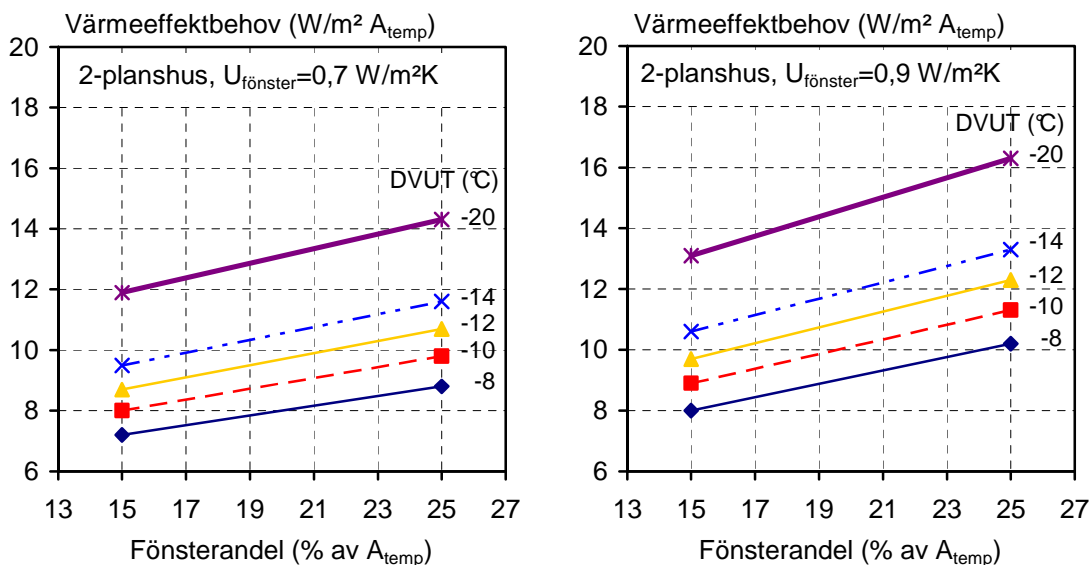

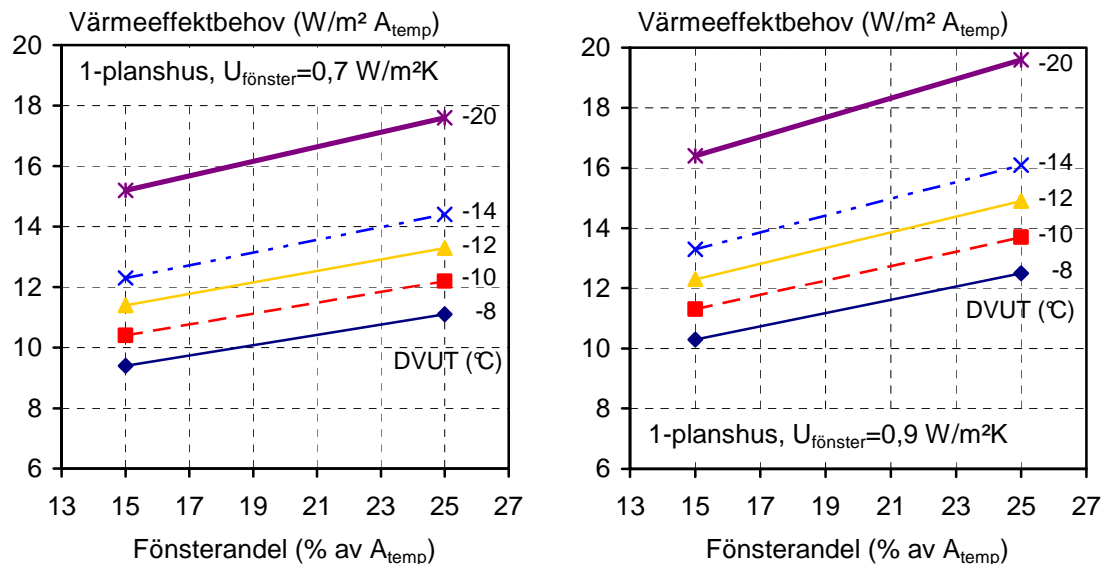

Figur 9 Beräknat värmeeffektbehov för 20 graders innetemperatur, internlast 4 W/m² och min. flöde 0,35 l/s m² med 80% verkningsgrad för olika byggnadsform och U-värde på fönstren.

Slutsatser och diskussion

Erfarenheterna från de tre praktikfallen visar att det är mycket svårt att klara effektkraven enligt gällande passivhusdefinition för bostäder. Den enkla teoretiska studien av en generisk volym stöder dessa slutsatser, men ger också en enkel förklaring till varför det förhåller sig så: Enplanshusen har en mycket ofördelaktig geometri med stora omslutande ytor i förhållande till volymen. Boverkets krav på en minsta rumshöjd om 2,7 meter i undervisningslokaler innebär redan att rumshöjden ökar i förhållande till normala bostäder. Då kraven på rumsakustik löses med nedpendlade undertak ökar byggnadens höjd än mer. Kombinationen av pulpettak för att dra fram kanalerna varmt och innanför tätskiktet gör att klimatskalet växer ytterligare. Det projekt som har bäst förutsättningar att lyckas som passivhus är därför troligen Bokliden. Här är fönsterytan låg, rumsvolymen har begränsats till ett minimum, och verksamheten innebär att man även har en viss, om än lägre, internlast under natten.

För framtida passivhus eller lågenergiprojekt bör man redan initialt försöka fundera över de volymmässiga proportionerna hos byggnaden för att skapa en gynnsam fördelning mellan omslutningsytan och den uppvärmda volymen. Att bygga i ett eller flera plan är därmed en central fråga. Tillämplighetskraven måste naturligtvis då vägas mot energiaspekterna. För förskolor i ett plan kan man också överväga att placera avdelningarna rygg i rygg, så att husbredden ökar upp mot 18-22 m för att skapa en kompaktare volym.

Problemen med höga effektbehov gäller dock främst nattetid, då internlasten är låg. Dagtid har man i dessa verksamheter en hög internlast, och även stora ventilationsflöden, vilket innebär att man dagtid inte har några problem att föra fram värmen med luft. Det är möjligt att en tyngre stomme hade varit gynnsam, dels dagtid för att dämpa temperaturökningen av internlasten, samt att ackumulera denna inför natten, vilket också troligen hade kunnat sänka maxeffektbehoven något. Detta har dock inte studerats via några simuleringar i dessa projekt.

En av de största osäkerheterna i beräkningarna av energibalansen torde vara just uppskattningen av internlasterna och deras variation över dygnet. Därmed blir även uppskattningen av effektbehoven behäftad med osäkerheter som relativt sett kan vara ganska stora, särskilt när vi rör oss på så låga nivåer som råder för passivhus. Metodiken för att bestämma internlast, och för att bestämma internlastprofiler borde utvecklas. Det är naturligtvis möjligt att utifrån tillgänglig statistik på verksamhetsel bryta ner detta till ett effektbehov per timme, med det finns ofta osäkerheter i vad som ingår i uppmätta värden och om det passar för den planerade verksamheten. Intervjuer med brukarna om deras användning av lokalerna är ett annat sätt att försöka förstå internlasterna för att kunna bestämma dem med större säkerhet. Om verksamheten ändras, ändras dock även förutsättningarna. Man bör därför fundera över hur man bör simulera dessa byggnader, om man skall låsa fast internlasten till ett visst värde, och om den skall vara konstant eller variera i en dynamisk simulering. Riktlinjer och råd vid dyna-

miska simuleringar borde därför förbättras, så att det blir tydligare hur effektbehovet skall bestämmas, om det alls är så relevant för denna typ av lokaler. Fokus kanske istället borde ligga på inneklimatet och energibehovet, som dock inte varit fokus för denna uppsats. Diskussionen om vilka projekt som får kallas passivhus bör därför också fortsätta med ytterligare teoretiska såväl som praktiska studier för att följa upp de projekt som nu är på väg att genomföras, och för att dra lärdom av de beräkningar som utförts.

Referenser

BBR 12, Regelsamling för byggande, Boverkets byggregler, BBR, BFS 1993:57 med ändringar till och med 2006:12, Boverket (2006).

Brunbäck, H & Teinvall, O. (Mars, 2008). Preliminära resultat från pågående examensarbete vid Tyréns AB och Lunds tekniska högskola, Campus Helsingborg.

Forum för energieffektiva byggnader, Kravspecifikation för passivhus i Sverige — Energieffektiva bostäder, Energimyndighetens program för passivhus och lågenergihus, Version 2007:1 (2007).

Hallberg, Maria. Ansvarig arkitekt på Glantz arkitektstudio. Personlig kommunikation 2008-03-05.

Jansson, Ulla, Passiv houses in Sweden, Experiences from design and construction phase. Report EBD-T--08/9. Division of Energy and Building Design, Department of Architecture and Build Environemnt, Lund University, Faculty of Engineering. (2008).

Ruud, S & Lundin, L, Bostadshus utan traditionellt uppvärmningssystem- resultat från två års mätningar, SP Energiteknik, SP rapport 2004:31, (2004).

Wall, Maria, Energy-efficient terrace houses in Sweden, Simulations and measurements. *Energy and Buildings* volume 38 pp 627- 634. (2006).

Løvåshagen: Norges første lavblokkprosjekt med passivhusstandard

Tor Helge Dokka, SINTEF Byggforsk, 7465 Trondheim, Norge
Kjetil Helland, ByBo AS, Postboks 1137 Sentrum, 5809 BERGEN

Introduksjon

Løvåshagen er et leilighetsprosjekt med 80 leiligheter beliggende i Fyllingsdalen rett utenfor Bergen sentrum. Av de 80 leilighetene skal 28 bygges som passivhus og 52 som lavenergiboliger. Prosjektet er under oppføring, og de første leilighetene skal innflyttes høst 2008.

Dette paperet beskriver bygningstekniske og installasjonsteknisk konsept og løsninger for å nå passivhusstandard, samt foreløpige erfaringer fra byggeprosessen.



Figur 1: Løvåshagen prosjektet, med passivhus til venstre og lavenergiboliger til høyre. Illustrasjon: MIR/ABO Arkitektkontor.



Figur 2: Løvåshagen i perspektiv. Passivhusene er husene i front med solfangere på taket. Illustrasjon: MIR/ABO Arkitektkontor.

Byggteknisk konsept

Passivhusene består av to like lavblokker med 14 leiligheter i hver. Leilighetene varierer mellom 75 til 90 m²(BRA), med et snitt på 80 m². Lavblokkene er i to til tre etasjer, og har plate på mark og pulttak (se figur 2). Bærekonstruksjoner er i plasstøpt betong, bortsett fra yttertak som er luftet tretak med papptekking. Yttervegger er utfyllende bindingsverk, og gulv på grunn er isolasjon på kultlag med 100 mm påstøp. Svalganger har separat bæring, mens balkonger bæres med slanke stag som er forankret i stålkriver i betongdekke. Isolasjonstykkelser og konstruksjonsløsninger er vist i tabell 1.

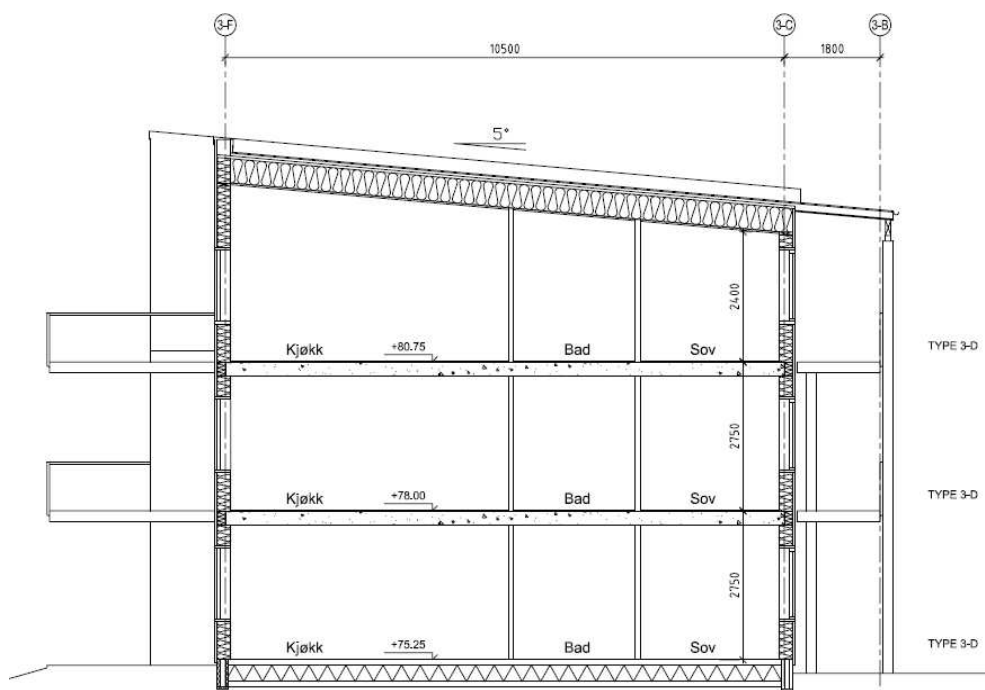

Figur 2: Snitt av passivhuset(lavblokk). Tegning: ABO Arkitektkontor.

Tabell 1: Isolasjonstykkelser og konstruksjonsløsninger.

Bygningsdel	Isotykkelse	Konstruksjon
Yttervegg – langvegg	350 mm	Dobbeltvegg-konstruksjon, med 98 mm innervange og yttervange, og 150 mm mellomliggende isolasjon.
Yttervegg – gavlvegger	400 mm	Dobbeltvegg-konstruksjon, som over men med 200 mm mellomliggende isolasjon.
Yttertak	500 mm	I-profil bjelker som åstak (bæres på skillevegger i betong), 3" lufting og papptekking.
Gulv på grunn	350 mm	Isolasjon på kultlag, med 100 mm påstøp

Tabell 2: U-verdier, kuldebroverdier og lekkasjetall for bygget.

	U-verdier/kuldebroer/lekkasjetall	Løsning
Yttervegg	$U = 0.10 - 0.12 \text{ W/m}^2\text{K}$	Dobbeltvegg-konstruksjon.
Yttertak	$U = 0.08 \text{ W/m}^2\text{K}$	Luftet tretak med I-profil bjelker.
Gulv på grunn	$U = 0.08 \text{ W/m}^2\text{K}$	Plate på mark med 350 mm isolasjon.
Vinduer	$U = 0.70-0.80 \text{ W/m}^2\text{K}$	3 lags ruter med argon, superspacer og isolert karm
Dører	$U = 1.0 \text{ W/m}^2\text{K}$	Godt isolerte ytterdører.
Normalisert kuldebroverdi	$\psi'' < 0.015 \text{ W/m}^2\text{K}$	Prosjekterte detaljer.
Lekkasjetall	$N50 < 0.6 \text{ ach}@50 \text{ Pa}$	Kontinuerlig vindsperrsjikt, prosjekterte detaljer, god KS byggeprosess.

Kuldebroer og lufttetthet

Det er i planleggingsfasen vært jobbet mye med å finne gode løsninger som minimerer kuldebroer og luftlekkasjer. Tiltak for å minimere kuldebroer har vært:

- Normalisert kuldebroverdi (kuldebrotap/BRA) skal ikke overstige $0.015 \text{ W/m}^2\text{K}$
- Bærende konstruksjoner i betong og stål, skal ikke penetrere det isolerende laget mer enn 10 cm, eller 1/3 av isolasjonstykkelsen.
- Svalganger bæres uavhengig av både innvendige og utvendige søyler, slik at man ikke bryter klimaskjermen.
- Av arkitektoniske årsaker har ikke balkonger uavhengig bæring, men det er forsøkt å minimere penetrasjon av klimaskjermen mest mulig, blant annet ved bruk av stag i rustfritt stål. Balkonger blir montert i etterkant av fasaden er ferdigstilt, slik at isolering og tetting rundt stag/stålkriver kan gjøres optimalt.

Tiltak for å oppnå et lekkasjetall lik eller mindre enn 0.6 oms/t:

- Primær lufttetting er utvendig vindsperrsjikt, som skal gå kontinuerlig over hele klimaskjermen etter rødstrekk-prisnippet (se figur 4).
- Sekundært lufttettesjikt er innvendig dampsperre/dampbrems. Pga. av penetrerende bærende konstruksjoner er dette vanskelig å få kontinuerlig, men vil allikevel være en ekstra sikring mot luftlekkasjer.
- Overgang mellom yttervegg og ringmur tettes omhyggelig.
- Rør, og kanalgjennomføringer reduseres til et minimum, og de som man får tettes det godt rundt.
- Det tettes omhyggelig mellom vindsperrsjikt på yttervegg og vinduer/dører.

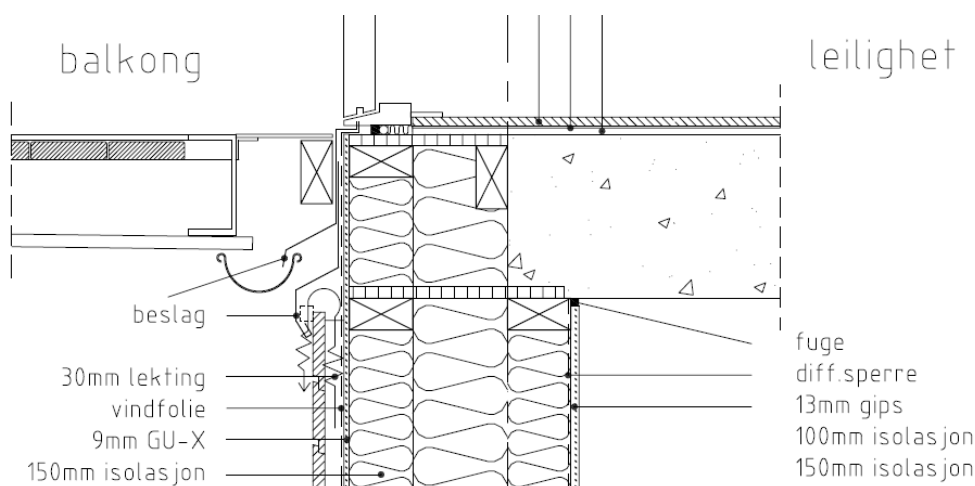

Figur 3: Detalj av kuldebrøløsning.

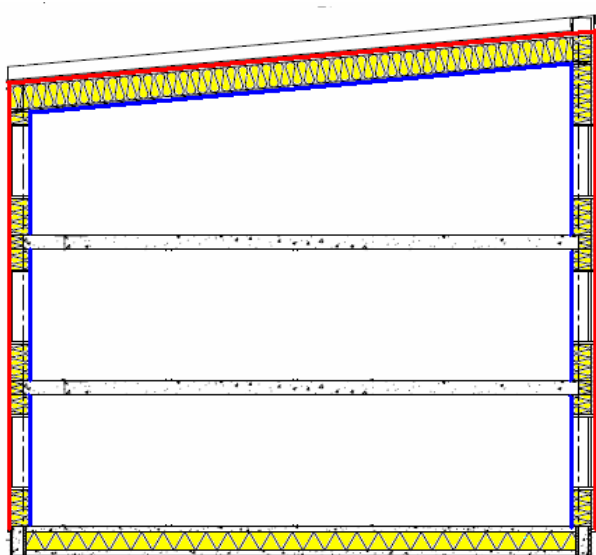

Figur 4: Prinsipp for lufttetting. Rød strek er utvendig vindtettesjikt (primær lufttetting), blå strek er innvendig dampsperre/dampbrems-sjikt (sekundær lufttetting).

Ventilasjonskonsept

Leilighetene vil ha hvert sitt ventilasjonsaggregat plassert i himling på bad. Aggregatene har høyeffektiv roterende varmegjenvinner med temperaturvirkingsgrad på 80-82 %. Aggregatene er utstyrt med nyutviklet aggregat fra Flexit utstyrt med såkalte EC-vifter som gir lavt energiforbruk til vifter (SFP-faktor under 1.5 kW/(m³/s)). Aggregatet er koblet til kjøkkenavtrekk, men ved bruk av kjøkkenvifte går luften i bypass utenfor varmegjenvinner for å unngå nedsmussing av rotoren. Friskluftinntaket er på svalgangssiden, og avtrekket føres over tak.

For å optimaliseres god luftkvalitet og lavt energiforbruk, kan anlegget kjøres i flere moduser:

- Ved normal drift bestemmes luftmengder ut fra friskluftkrav i oppholdsrom, og minimumskrav til avtrekk i bad og kjøkken.
- I hvilemodus reduseres luftmengdene til et minimum, slik at det kun fjerner forurensning mens det ikke er personer i leiligheten. Ventilasjonsaggregatet er koblet til styringssystemet i leilighetene, der en inneute bryter setter leiligheten i "hvilemodus".
- Ved bruk av kjøkkenvifte maksimeres avtrekk fra kjøkken og avtrekk fra bad minimeres ved hjelp av et motorstyrt spjeld. Dette er gjort fordi det i mange leilighetsprosjekter klages på problemer med fjerning av matos.
- Ved forsert avtrekk fra bad stilles motorspjeld slik at det trekkes av mest luft fra bad.

Ved forsering av avtrekk justeres også tilluftsmengden automatisk slik at det alltid er balanserte luftmengder.

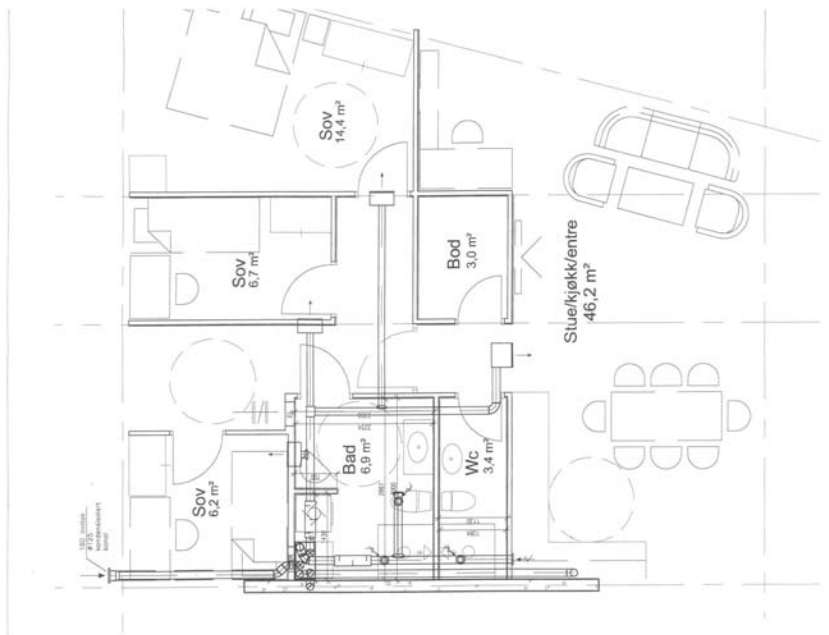

Figur 5: Kanalføringer i typisk leilighet.

Oppvarmingssystem

Oppvarmingssystemet er et forenklet vannbårent system (gjelder passivhusene). En enkel radiator plassert sentralt i leiligheten (stue/entre) dekker hele varmebehovet i leilighetene. I tillegg er det vannbåren varme i baderomsgulv av komforthensyn. Oppvarmingssystemet som er utviklet spesielt for dette prosjektet, er nærmere beskrevet i et eget paper [Dokka&Amdahl 2008].

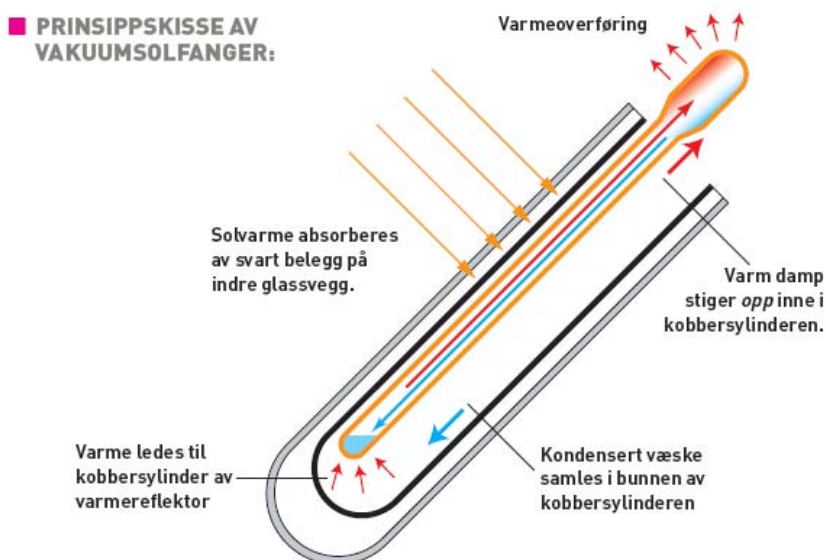

Figur 6: Prinsippskisse av vakumsolfanger. Illustrasjon: Jan Helge Johansen/SINTE Media.

Energiforsyning

I begge passivhusene har hver leilighet et eget solvarmesystem som dekker en betydelig del av varmtvannsbehovet (tappevann) og noe av oppvarmingsbehovet. Solfangerne er av typen vakumsolfangere som har meget høy virkningsgrad (se figur 6). Fordelen med denne type solfangerer er at det selv i perioder med lite sol og relativt lav utetemperatur produserer varme. Simuleringer viser at solfangeranlegget kan dekke ca. 50 %

av varmtvannsbehovet og 15-20 % av oppvarmingsbehovet over året. Når solfangerne ikke kan levere tilstrekkelig energi, dekkes resterende varmebehov av en elektrisk kolbe. En akkumulator/bereder på 300 liter er spesialdesignet for prosjektet, og er plassert i teknisk nisje i på bad.

Energiberegninger

Tabell 3 viser beregnet oppvarmingseffekt- og årlig oppvarmingsbehov for ulike etasjer i en av lavblokkene (14 passivhusleiligheter). Årlig oppvarmingsbehov er godt under kravet på 15 kWh/m²år for passivhus. Alle simuleringer er gjort med simuleringsprogrammet SCIAQ Pro 2.0 [Dokka 2005]

Tabell 3: Simulert effekt- og energibehov til oppvarming.

	Oppvarmet gulvareal	Oppvarmingseffekt	Oppvarmingsbehov
1 etg	404 m ²	4485 W	5522 kWh/år
2 etg	404 m ²	4172 W	4165 kWh/år
3 etg	316 m ²	3751 W	4692 kWh/år
SUM	1125 m ²	12408 W	14379 kWh/år
Snitt		11 W/m ²	12.8 kWh/m ² år

Erfaringer fra byggeprosess

Pr. i dag er hus 4 (passivhus) ferdig tett og ferdig isolert. Hus 3 (andre passivhuset) er straks ferdig med utvendig vindtetting. Så langt har de store utfordringene vært værbeskyttelse og oppnåelse av tetthetskravet.

Bergen setter spesielle krav til værbeskyttelse og tiltak for å unngå innbygging av fukt i konstruksjonen. Passivhus med meget stor isolasjonstykkelse setter selvsagt enda større krav til å unngå innebygget fukt, siden uttørkingen av konstruksjonene vil foregå mye tregere. Sikring av dette er gjort ved å vind- og værtette bygget helt før det tørkes ut innvendig (avfuktere). Det er satt maks krav til fuktnivå i bindingsverk og betong før isolering og innvendige arbeider påbegynnes. Utvendige fasader er også beskyttet med presenning over utvendig stillas.



Figur 7: Trykktesting av leiligheter med kun utvendig vindtetting.

Luftlekkasjemålinger med kun utvendig vindtetting for hus 4 (passivhus) viser at kravet på 0.6 oms/t er tilnærmet oppnådd med kun utvendig vindtetting. Den største utfordringen har vært tetting rundt vinduer, og da særlig i underkant av vinduer.

Foreløpige konklusjoner

Erfaringene så langt viser at det er mulig, og teknisk relativt enkelt å bygge passivhus i Bergens-klima. Passivhusene i Løvåshagen selges med en kvadratmeterpris som er lavere enn mange tilsvarende leilighetsprosjekter i Bergen [Erstad&Lekven 2008], se figur 8

Passivhusene har krevd mye ekstra prosjektering, særlig tidlig i planleggingsprosessen. Men byggherren framholder at denne nøye planleggingen har ført til mindre feil og ombygginger så langt i byggeprosessen, sammenlignet med konvensjonelle byggeprosjekter. Kostnadene for ekstra prosjektering er derfor mer enn oppveiet ved at kostnader for feil og uforutsette ting har blitt redusert.

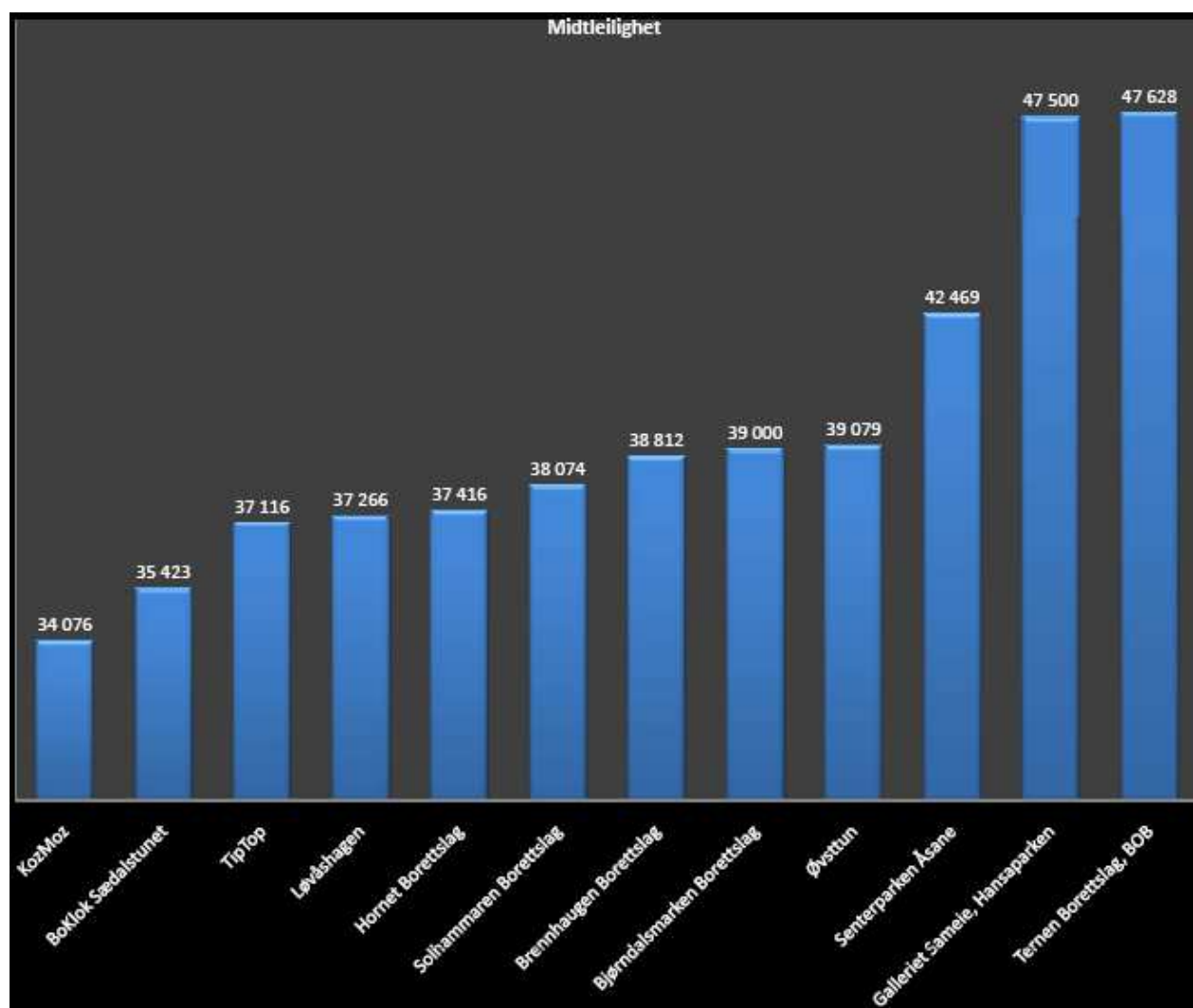

Figur 8: Sammenligning av kvadratmeterpris for ulike leilighetsprosjekter i Bergen.

Komponenter som tilfredsstillter passivhuskravene har stort sett latt seg realisere, men det er fortsatt behov for flere produsenter og større utvalg i løsninger/produkter. Særlig vil det være ønskelig med balkongdører og ytterdører med bedre U-verdier, enda mer effektive ventilasjonsaggregater, og større utvalg av oppvarmingssystemer og energiforsyningssystemer (fornybare) tilpasset passivhus. Produkter, løsninger og systemer for å oppnå lekkasjetall-kravet for passivhus (0.6 som/t) på en enkel måte er også sterkt ønskelig. Flere kompetente entreprenører og byggmesterfirmaer som spesialiserer seg på passivhus-utførelse vil også senke kostnadene og bedre lønnsomheten.



Figur 9: Befaring på taket av hus 4 (passivhus), der solfangere skal monteres.

Utredning av Løvåshagen og ekstra investeringer i energiltak har blitt økonomisk støttet av Husbanken og Enova.

Referanser

[Dokka & Amdahl 2008]

Dokka, Tor Helge og Amdahl Leif, Paper på PassivhusNorden 2008 , Trondheim 2- 3 April,, Norge.

[Dokka 2005]

Dokka KA, Dokka TH, SCIAQ Pro – Simulation of Climate and Indoor Air Quality, www.programbyggerne.no, 2005.

[Erstad&Lekven 2008]

Prissammenligning av leilighetsprosjekter I Bergen. Erstad & Lekven AS, Januar 2008
<http://www.erstad-lekven.no/sitefiles/4057/ELU/KozMoz/Prissammenligning/Sammenlignedepriserperjanuar2008.pdf>

Session 11

Planning and design of passive houses

Charlotte Højmark, Flemming Hoff Jakobsen

KomfortHusene, 10 different single family houses under construction.....292

Odd Karl Steinsvik

I-Box 120 – Norges første passivhus300

Igor Sartori, Bjørn J. Wachfeldt

Case study on retrofit of a Norwegian school: possible to achieve the passive house standard?301

David Benjamin

Experience with the design process for almost passive houses for low cost housing in the extreme cold climates of North America: Lessons for Scandinavia?309

KomfortHusene, 10 different single family houses under construction.

By Charlotte Højmark, Iover Scandinavia, Østermarksvej 4, 6580 Vamdrup, Denmark
and Flemming Hoff Jakobsen, Hundsbæk & Henriksen A/S, Gunhilds Plads 6, 7100 Vejle, Denmark

Vision of the project

The vision of the project is to spread knowledge of the passive house concept in Denmark, to gain and share experience of the challenges and solution of building passive houses in Danish tradition and in Danish climate and to demonstrate that it's possible to build nice, modern and comfortable homes in Danish building tradition as passive houses.

This in order to influence on the building regulations and energy politics and to bring Danish building branch back in the first division concerning buildings energy performance

The project

Iover Scandinavia took the initiative, to start the project. The idea is to let 10 different consortia's build 10 different single family dwelling, all placed together. When placed together and build on the same time the 10 houses can function as a demonstration and exhibition project.

Important items in the project is learning by doing and the sharing of knowledge.

All participants, both in the consortia's and the building material producers that has joint the project, is committed to be open and share ideas, experience and knowledge. In the first place the sharing knowledge is between the participants.

When the project is concluded the gained experience will be shared with the rest of the building branch through publishing, seminars, etc.

Economy

The houses are built and sold on market conditions







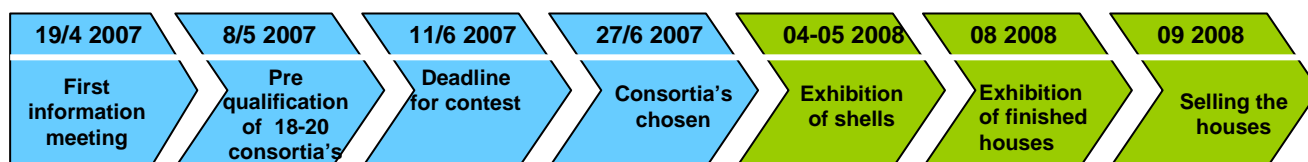

The company, "KomfortHusene", that consist of an investor company and a savings bank, bought 10 sites placed together in an attractive neighbourhood.

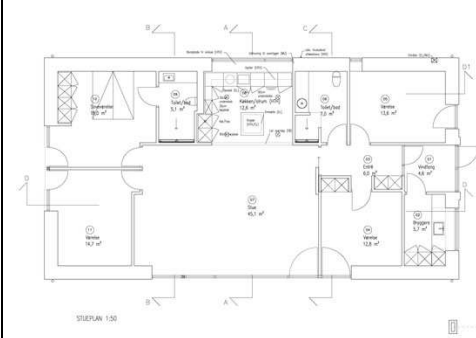

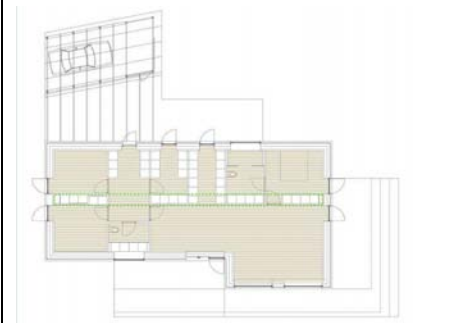

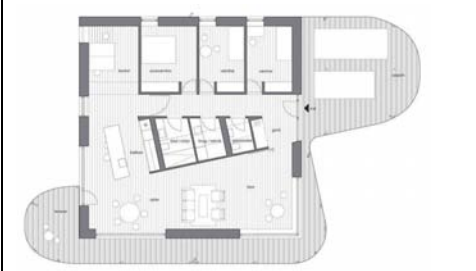

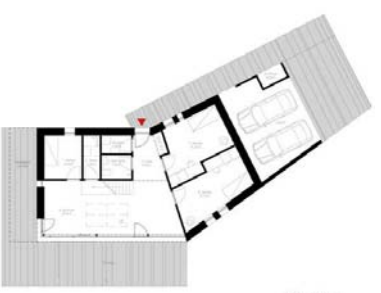
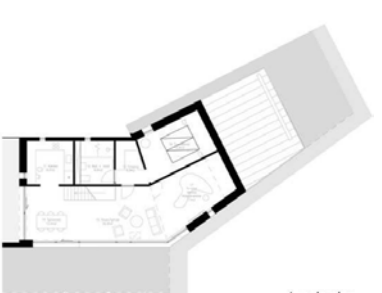

Through a contest the 10 consortia's where chosen, and each consortia made a common building contract with the company KomfortHusene. From the consortia's point of view the houses is already sold. This guaranteed the economy and made it attractive for the consortia's to participate.

Time Schedule

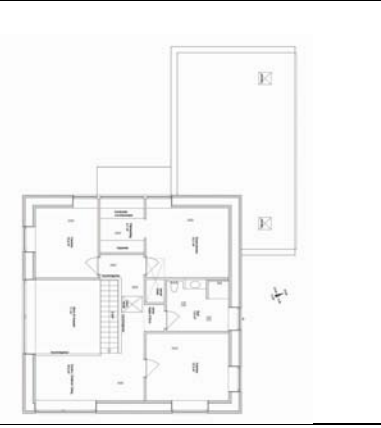

The 10 houses

		<p>1 story 182 m² treated floor area Cavity wall with brickwork inside and outside</p>
		<p>1 story 177 m² treated floor area Cavity wall with porous concrete inside and brickwork outside</p>
		<p>1 story 169 m² treated floor area Prefabricated woodframe elements Façade: mortar rendering directly on hard mineral wool</p>
		<p>1 story 180 m² treated floor area Prefabricated wood frame construction. With I-shaped stud's Façade of plywood board and a wooden grid.</p>
		<p>2 storeys (10 m² loft platform) 210 m² treated floor area Wall elements of massive wood Façade of brickworks</p>

	 <p>Stueplan</p>	 <p>1. sals plan</p>
<p>2 storys - 224 m² treated floor area - Wall elements of massive wood - Façade of woodcladding</p>		
		
<p>2 storys - 198 m² treated floor area - loadbearing construction of timberframes Façade: mortar rendering directly on hard mineral wool</p>		
 <p>2</p>		
<p>2 storys - 220 m² treated floor area - Inside wall of light concrete - Façade of brickwork</p>		
		<p>1 story 157 m² treated floor area Wall elements of massive wood Façade: mortar rendering directly on non organic board</p>

kWh-huset a passiv house in precast concrete units.

The last of the ten houses is kWh-huset, with special focus on the positive effect of heavy constructions



Developer: Hundsbæk & Henriksen

Architects: Westergaard Arkitekter A/S

Technical Consultant: Hundsbæk & Henriksen

Contractor (building): Kurt Kirkegaard A/S

Contractors (precast units): Expan A/S

Contractor: (Ventilation): Nilan A/S



Comfort House in two levels, 245 m²
in precast concrete units
The Building is under construction,
and will be finished in summer 2008

Vision:

kWh-huset must be a convenient house.

Our stated objective is to design a passiv building in modern Danish architecture for the modern family in a healthy standard and in heavy building materials.

A house for one family, with open and bright rooms, fulfilling the requirements of the “PassivHaus Standard”
The décor solutions of the rooms are functional, and the private atmosphere is well received both in- and outside.

Keywords:

- Must comply with the “Passivhaus Standard”
- Reliable technical solutions
- Modern Danish architecture
- Comfort

Layout



Ground floor

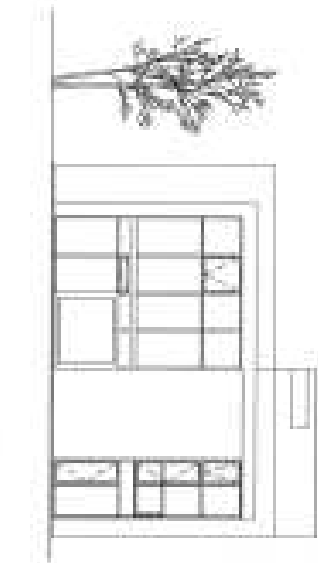

South facade

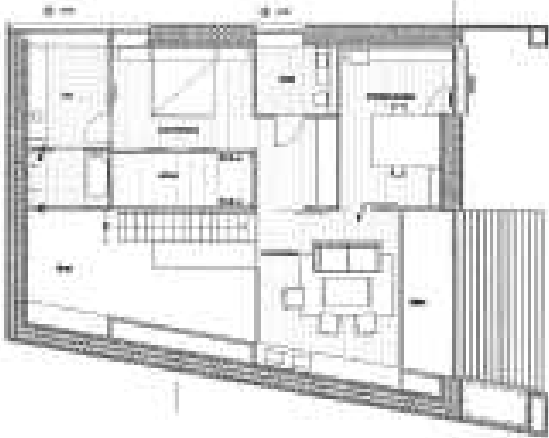

Second floor

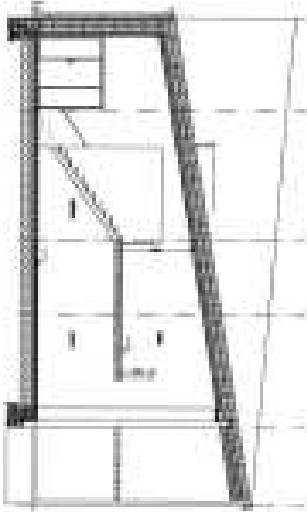

Sectional view

Why precast concrete as building envelope?



In Denmark is the Weather conditions often moist and the air humidity frequently very high comparing with the modern family often prioritise spare time, sport and friends before house work as painting and keep in repair.

That is why we want to make a family home with a minimal need of maintain. And of cause why the Danish architectural design has for century been in brickwork.

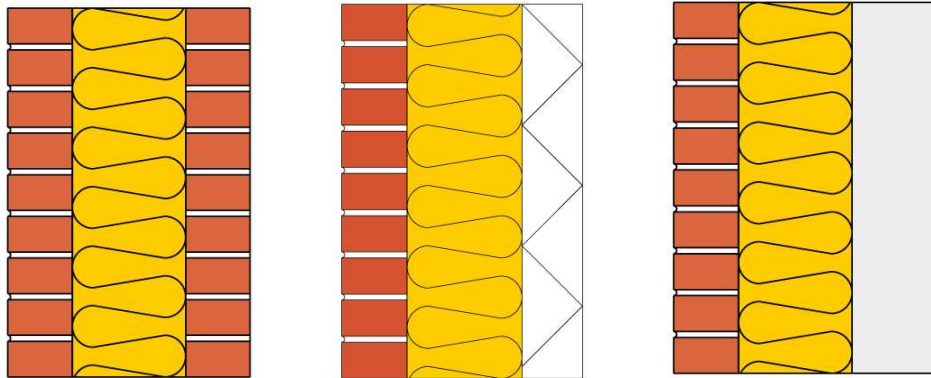

Examples of traditional Danish cavity walls with brickwork as the outer surface. Outside surface of concrete is traditionally more common on multi story buildings

With precast concrete inside we have:

- Long Lngevity of the building in the Danish climate.
- Indoor Climate markt precast concrete.
- Good Acoustic property
- Good Firesafe property.
- Thermal accumulation/conductivity in good balance with circadian rhythm
- Denseness – as well over years.
- Installation electrical and ventilations fittings are concreted ex works
- Static well-defined and solid building system.
- Short building time, fast closing of the building.
- Resources and environmental parameter with regard to service and maintain.
- New study show CO₂ neutrality over time compared to wooden houses

- and the opportunities too make a building envelope of : precast concrete - brickwork – wood, or other surfaces. The concept is the same.

Thermal accumulation and conductivity is vital for a passiv House.
The Thermal condutvity can help moving heat from south facing room too room facing north.

I-Box 120 – Norges første passivhus

Paper as power point presentation
Av Odd Karl Steinsvik

Abstract

I-BOX 120- Norges første passivhus.

Bygget: 2005
Sted: Tromsø 69°40N/ 18°55Ø
Areal: 120m² boligareal

Beregnet energiforbruk: Oppvarming – 0 kwh/ år
Totalforbruk – 5000 kwh/ år

Ikke designet ut fra å kun tilfredsstillende europeiske minimumskrav til passivhus (15kwh/ år)

DESIGNKRITERIUM: Ingen oppvarmingssystem ut over forvarming av ventilasjonsluft.

BYGGEMETODE: Kompaktre konstruksjon med krysslimte plater.
Utvendig mineralull- isolasjon.
U- verdier bedre enn passivhusstandard.
Omluft- sirkulasjon med fjerning av støv fra inneluft.

ENERGISYSTEM: Motstrømsveksler på ventilasjon.
Luft til vann varmepumpe for oppvarming av bruksvann.
Solfanger for oppvarming (forvarming) av bruksvann.
Jordvarmekrets på friskluftinntak for forvarming av friskluft. (Kan også gi ”passiv” kjøling.)
Automatisk lysstyring.
Temperaturstyrt solavskjerming.

Huset er en prototyp som har dannet grunnlag for en 0- serie på 10 boliger som ferdigstilles årsskifte 2007/2008.

Jfr.: ”Byggekunst” 01/07.

Case study on retrofit of a Norwegian school: possible to achieve the passive house standard?

Igor Sartori^a, Bjørn J. Wachnefeldt^b

^aDept. of Architectural Design, History and technology, NTNU, Trondheim, Norway

^bDept. of Building and Infrastructure, Sintef Byggforsk, Trondheim, Norway

Abstract

The energy demand of an existing school building is simulated with a dynamic software tool using a model calibrated against metered data. A series of retrofit measures are simulated in order to achieve the performance requirements for passive house standard for school buildings. The implemented energy saving measures are grouped into the following sets: controls, lighting, ventilation, windows, insulation and additional measures to fulfil the passive house definition. The order of their implementation is meant to represent an increasing level of complexity for the operations to perform. The results show the incremental effect of each set of measures and compare it to the equivalent energy class achieved. The cumulative effect of all the measures allows to meet the passive house requirements on both net heating energy and total primary energy demand. Particular attention had to be dedicated to the retrofit measures for the ventilation system.

Introduction

The building used in this case study is the Steindal elementary school, located in Trondheim, Norway (Latitude: 63°36'; Longitude 10°23'). The purpose of this work is to analyse, with the aid of computer simulations, what measures are necessary to undertake in order to achieve the passive house standard for this school building. The Steindal School serves some 340 students and 40 administrators. The main building was built in 1978, with an additional wing, or annex, constructed in 1997; the total area is ca. 4800 m² divided between two floors. The school is located on the top of a small hill and is characterised by a glazed façade on the north side, as visible in Figure 1 b), while in the south side the lower storey is under ground level because of the hill's slope.

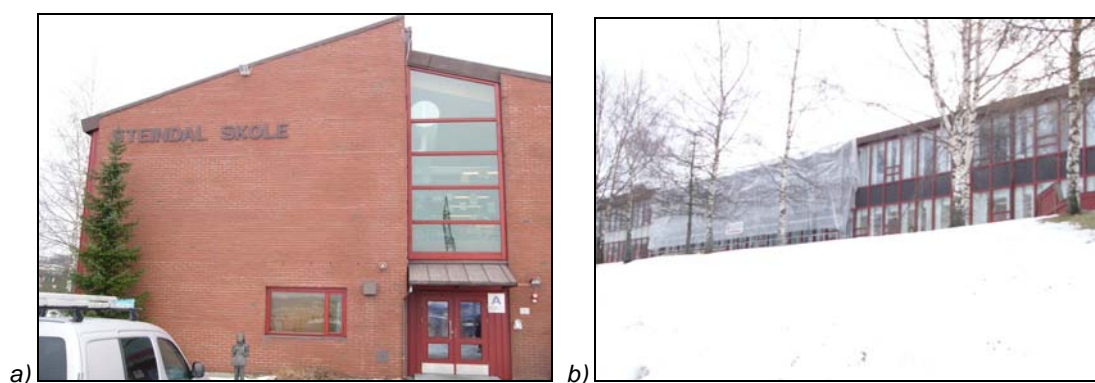

Figure 1: Steindal school a) west façade, and b) north glazed façade.

Outdoor air is supplied by two balanced ventilation systems with heat recovery, one in the main building and one in the annex, while heating is supplied locally in each room by electric resistance radiators; the building has no cooling system. Ventilation air in the annex is heated to the supply temperature (18°C) by an electric coil, while in the main building the heating coil is supplied with hot water produced by an electric boiler. Electricity is then the only energy carrier used by the school, and hourly data on metered consumption are available from the local electricity company. The cumulative energy consumption is presented in Figure 2 and shows a

significantly lower consumption in 2006 and 2007. While the differences between years 2002 to 2005 are mainly due to temperature differences, the gap registered for 2006 and 2007 is predominantly the result of changes in the schedules of operation and temperature settings made by teachers and students of the school in the context of a communal programme aimed to teach and promote energy savings. All the temperature sensors and other controls in the school are remotely connected to a control room in the local municipality, from where all the settings can be made. The programme was initiated in 2006 and the energy saving initiatives included mainly a reduction of operating time for the ventilation system and the temperature settings in the locals. The ventilation system in the main building serves locals with diverse occupancy schedules, as offices, classrooms and the gym. Because the gym is normally used once or twice per week in the evening by local sport associations or music bands, the ventilation system was on until late in the evenings. After the energy saving program began the ventilation system stops at 16:00h and is eventually switched on again only in the evenings of occupancy. Ventilation starts at 6:00h in the morning in order to assure clean air in the locals by the time occupancy begins, around 7:30h. The temperature in classrooms and offices were set to be between 20-21°C instead of the previous 23°C or higher settings. However, the somewhat higher consumption in 2007 may be partly explained by an increase in the temperature

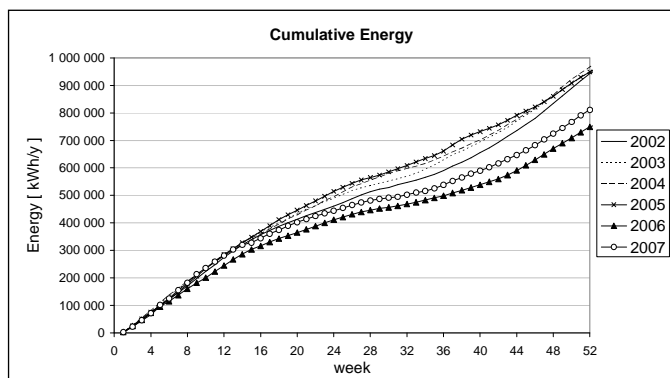

Figure 2: Energy consumption from 2002 to 2007.

settings for some of the classrooms, as some teachers had lamented the locals to be too cold [Steindal, 2006]. Besides, it shall be mentioned that in the offices it is possible to manually adjust the temperature settings.

Method

Data were gathered from technical drawings, documentation, site visits to the school with the caretaker and meetings with building managers and architects. The Trondheim municipality provided ventilation and temperature setting data from their remote control centre. Drawings and documentation were obtained from the school, and conversations with building managers and architects provided further information about the construction. Dialogue with school teachers and administrative staff provided detailed information on

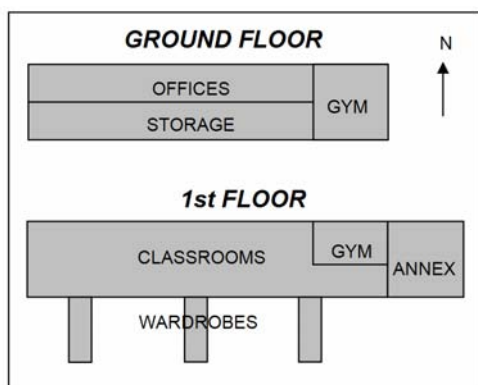

Figure 3: Floor plan of the school.

occupancy schedules. The building was modelled using “EnergyPlus”, a dynamic simulation software [Energy Plus, 2006]. For modelling purposes the school was subdivided into seven thermal zones; six of them are shown in Figure 3, the seventh being the under-roof unheated buffer space. The energy consumption has been simulated and the computer model was calibrated against metered energy consumption for year 2006. The calibration procedure is explained in the detail in a previous work, [Sartori and Ricker, 2007]. In simulating buildings’ energy consumption there is always an intrinsic uncertainty with which it is possible to know the many required parameters. The calibration was performed both manually and with the support of a Monte Carlo method, in an attempt to obtain a more robust model. The Monte Carlo method revealed helpful for the calibration process, allowing identification of the most critical parameters and improving the overall goodness of the model. In addition it allowed identifying a set of top-twenty calibrated solutions obtained by different combinations of the parameters and all satisfying predefined criteria. The rationale for this was that it would help when trying to asses and compare the potential effect of alternative energy saving measures, because the results would be less affected by the uncertainties on the input parameter values. Nevertheless, in the work presented here the purpose is to apply a set of modifications to the model, one on top of the other, until the passive house performance is eventually achieved. The final building will then be completely different from the original one in all its major parameters (as U-values of envelope parts, properties of the ventilation system and

so on). Hence, it is not interesting here to keep on working with the set of top-twenty calibrated solutions, because this would not add useful information in this case. Only the manually calibrated model is used here; it shall be reminded that manual calibration – by means of tuning the values of those parameters identified as more important until a satisfactory match with metered data is achieved – is the conventional way of performing calibration in building energy simulation. Besides, the base model used here to represent the school building in its actual status slightly differs from the one presented in the above mentioned paper, due to a few details. A closer analysis to the energy demand of the building and further talk with technical personnel allowed

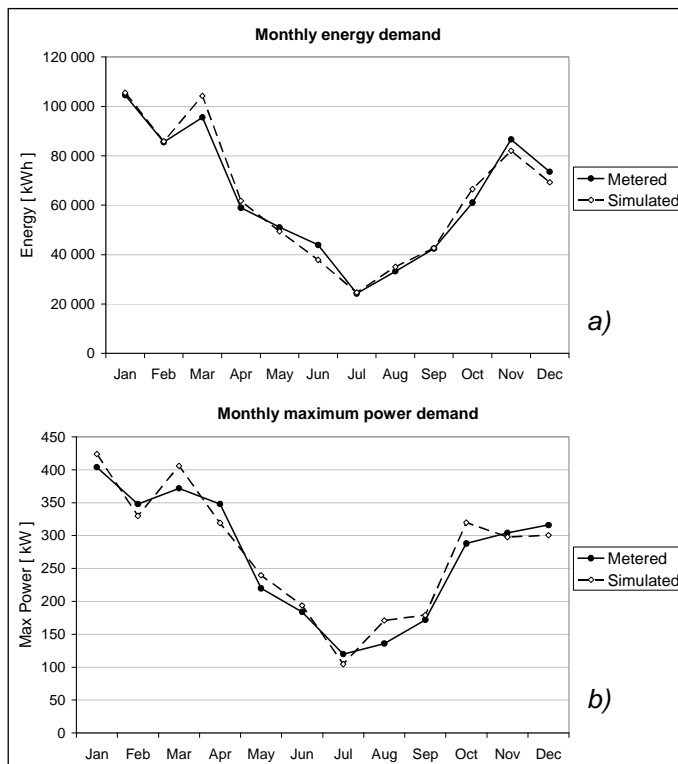

Figure 5: Metered vs. simulated monthly values for a) Energy and b) Power.

model and its similarity or non- with the metered data series. Metered and simulated data are plotted in blue and yellow respectively, and the outdoor temperature (dry bulb) is also plotted in brown, so that correlations between temperature and energy demand can be observed.

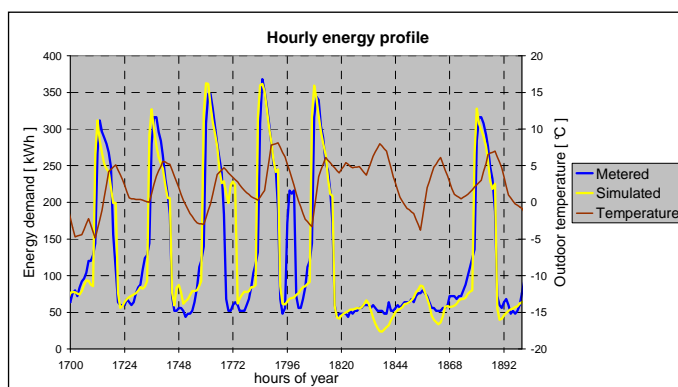

Figure 4: Segment of hourly time plot for energy demand and temperature.

understanding the nature of some baseload – a load present also out of occupancy time – that before was not fully understood. Basically, the gym’s wardrobe and the wardrobes in the first floor are heated by means of a floor cable system that is manually regulated, hence out of the remote control centre in the municipality. Again, both metered data and results from simulations are on an hourly basis; but when grouping up the data to monthly figures, this can be done in slightly different ways. In the previous work a month was considered simply as the sum of 720 hours, while here the months have been considered with their actual length. For these reasons the graphs shown in Figure 5 are somewhat different from those presented in [Sartori and Ricker, 2007]. The statistical indicators that quantify the ability of the model to reproduce the metered results are nearly unchanged. For a full explanation of the statistical indicators and their meaning reference is made to [Reddy and Maor, 2006].

Another way to compare the simulated results against the metered consumption is to plot them on a time series graph as shown in Figure 4. Similar plots were used during the calibration process to help understanding the behaviour of the simulation and its similarity or non- with the metered data series. Metered and simulated data are plotted in blue and yellow respectively, and the outdoor temperature (dry bulb) is also plotted in brown, so that correlations between temperature and energy demand can be observed. The graph shows a segment of the yearly hourly series, corresponding to a week in March. The peaks in energy demand corresponds to daily occupation time, when ventilation, lighting and other equipment are on. The valleys, on the other hand, correspond to nights and weekends when the school is not occupied and the temperatures are set back a couple of degrees. It can be seen that while an evening of gym occupancy was simulated on a Wednesday it actually took place on a Thursday; but this will not affect the overall result when calculated on monthly or yearly basis. It is also possible to notice the correlation between outdoor temperature and energy demand; when the former decreases the latter increases.

Results and discussion

The calibrated model of the school building has been modified by changing some parameters according with the kind of intervention simulated. The areas of intervention were grouped up in: controls, lighting, ventilation, windows, insulation and other changes necessary to comply with the passive house standard. The changes were applied in sequence and with a cumulative effect. The order of their implementation is meant to represent an increasing level of complexity for the operations to perform; hence the order is likely to represent also an increasing cost for the kind of intervention, even though costs are not explicitly addressed in this paper. The list of interventions, or set of measures for energy saving, is shown in Table 1 with a summary of the parameters that have been modified and their values before and after the intervention respectively. The corresponding results are shown in Figure 7. It can be noticed that none of the measures contemplates reduction of energy for equipment, even though some reduction could be assumed due to more energy efficiency appliances in the offices, computer lab and kitchens (refrigerators and so on). Also, it is not considered necessary to introduce an active cooling system; the pupils are not at school during summer, and simulations of natural ventilation through window openings showed sufficient to keep comfortable temperatures in the north facing office area of the building.

The ultimate goal of the energy saving measures is to achieve the compliance with the passive house standard for a school building, as defined in [Passivhaus-Schulen, 2006], which is a collection of works on school projects culminating with the definition of design criteria. The major requirements are the same as for residential buildings: a net heating demand not higher than 15 kWh/m²y and a total demand expressed in primary energy units not higher than 120 kWh/m²y.

Table 1: Parameter settings for the energy saving measures.

Set of measures	Parameters modified	Before	After
<i>Original^a</i>	Weather file:	Trondheim 2006	Oslo Typical Meteorological Year
	Temp. settings in classrooms:	20 / 18 °C	21 / 19 °C
<i>Controls</i>	Heating in wardrobes and storage area (18°C):	Manual, power regulation	Automatic temperature regulation
<i>Lighting</i>	Power in use during occupation:	57 kW	29 kW (~50%)
<i>Ventilation</i>	Ventilation type:	Centralized (Main build.)	Zone by zone
	Ventilation rate during full occupation:	~ 46 000 m ³ /h (3.5 ach)	~ 25 000 m ³ /h (1.9 ach)
	Heat recovery efficiency:	55%	80%
	Specific Fan Power:	Main 2.9, Annex 1.6 kW/(m ³ /s)	All 1.3 kW/(m ³ /s)
<i>Windows</i>	U-value glass:	1.9 – 3.3 W/m ² K	0.8 W/m ² K
	Solar Heat Gain Coefficient (g-value):	0.39 – 0.78	0.5
	U-value frame:	1.5 W/m ² K	0.7 W/m ² K
	Zone infiltrations:	0.1 – 0.3 ach	0.1 ach
	Temp. settings:	21 / 19 °C	20 / 18 °C
<i>Insulation^b</i>	U-value walls:	0.31 W/m ² K	0.1 W/m ² K
	U-value roof:	0.19 – 0.28 W/m ² K	0.07 + ΔU = 0.03 W/m ² K
	U-value ground floor:	0.67 – 1.44 W/m ² K	0.20 + ΔU = 0.06 W/m ² K
	Ground temperatures:	14 – 16 °C	9 – 11 °C
	Zone infiltrations:	0.1 ach	0.05 ach
<i>Passive House</i>	Heating source priority:	Room heaters	Ventilation air
	Hot water production ^c :		
	<ul style="list-style-type: none"> • Source • Efficiency 	Electricity 90%	Natural gas 85%

^a with respect to the model in [Sartori and Ricker, 2007]

^b ΔU are due to thermal bridges

^c also for the heating coil in the ventilation system

The original building is simulated here using climate data from a typical meteorological year for Oslo rather than year specific data for Trondheim. This is done with the intention to represent a standard situation, since in [Wigenstad et al., 2005] the Oslo climate is prescribed to be used as the reference climate for assessment of building's energy class, in accordance to the European Directive on Energy Performance of Buildings (EPBD).

The temperature settings in the classrooms are one degree higher than in 2006; again, this is done to represent a standard situation as the setting of 21°C – and 19°C in setback – is prescribed by the Norwegian norm for calculation of energy requirements [NS3031, 2007]. Also, it is likely that as explained above the temperature in the classrooms have been set to higher reference values after 2006 for reasons of comfort. In these operating conditions the energy demand for the original building amounts to 183 kWh/m²y. According to the classes definition given in [Wigenstad et al., 2005] this school building belongs to the class E (161-190 kWh/m²y), which is supposed to be the energy class representative of the average condition of today's stock. This fact is particularly interesting because it allows considering this case study as representative of an average situation in the stock of existing school buildings.

The heating in the storage/workshop locals and in the wardrobes is controlled by manually selecting the operating power of the heaters or floor cables. It has been noticed that in this way the rooms were heated more than necessary, and also that heating was generally on also during weekends and periods of vacation (when the setback should be 14°C), and to some extent also during summer ([Steindal, 2006]). Substituting the manual control with an automatic one and optimising the temperature settings and the schedules allows to reduce the energy demand to 163 kWh/m²y, which is still in the range of the energy class E but close to the limit of class D; in Figure 7 this is emphasized by the label "E+".

The next intervention consists in substituting the light tubes and light bulbs with energy efficient ones. It is estimated that such change has the potential to nearly halve the energy demand for lighting. Nevertheless, as lighting is also a source of internal gains, reduction of lighting energy is accompanied by an increase in heating energy to compensate for the diminished internal gains, at least during the heating season. The overall effect in reducing heating demand is small and it results in a figure of 159 kWh/m²y, equivalent to a class D (131-160 kWh/m²y).

Intervention on the ventilation system involves changing several parameters. The new system (unique for all the school) is supposed to be operated zone by zone, according to the occupancy schedule. The system can be still centralized, but in contrast with today's on/off functioning, the fans can be operated at variable speed and the zones can be included or excluded by means of automatically controlled dampers. If necessary, two fans can be used in parallel to supply the maximum required flow but allowing a wider range of reduced flow operation as one of the two can be switched off when needed (variable speed fans have a lower limit on the fraction of nominal speed at which they can operate). The system ducts and components are supposed to offer low pressure drop, so that low pressure and high efficiency fans can be used, resulting in an overall Specific Fan Power of 1.3 kW/(m³/s) instead of the actual 2.9 in the main building and 1.6 in the annex. Today's heat recovery units are a cross flow in the annex and a rotary wheel in the main building. Real time data obtained by the remote control centre at the municipality revealed some anomalies in the operation of the rotary wheel. Probably due to some problems with the control logic the wheel was found to operate often at its minimum allowed speed (like a "safety mode") instead of its nominal speed. This inconvenience may be the cause of a reduced efficiency of the heat recovery unit that should warranty 75% temperature efficiency according to label data; besides, the rotary wheel is still the original one from 1978. However, the calibration process performed in [Sartori and Ricker, 2007] with the help of the Monte Carlo method suggested a value of 55% as most probable actual efficiency of both systems, in the main and in the annex buildings. The new ventilation system has a heat recovery unit with an efficiency of 80%. The maximum ventilation flow rate, when all the zones are served, is also reduced; the reason for this requires some more explanation and Figure 6 will serve the purpose. The required ventilation rate is defined in relation to the occupancy intensity, or level, in the locals expressed in persons per square meter. The guide to the Norwegian technical norm of the building code [TEK VEIL, 2007] says that in order to guarantee desirable levels of air quality a certain air flow rate has to be supplied to compensate for emissions from both occupants and materials. About materials three levels are defined: low-emitting, normal and undocumented materials, with corresponding air flow rates of 0.7, 1 and 2 l/s/m². About persons a flow rate of 7 l/s per person shall be supplied; the central issue is how to determine the occupancy level. The same [TEK VEIL, 2007] offers a table of maximum occupancy for different kind of locals, specifying that where available actual data on occupancy shall be used in place of those provided by the table. The differences between maximum occupancy and real occupancy are significant. For example, for a school the maximum occupancy is set to 2 m² per person while the actual occupancy of the first floor of Steindal school, where the classrooms are, is about 6.5 m² per person. The maximum values are safety values meant to guarantee good air quality with a large margin; they could be correct values for example for a closed teaching room with high density of pupils,

but it is not justifiable to adopt the same value for an entire zone that also comprises playrooms, corridors and a number of spaces dedicated to various activities other than frontal teaching. The actual occupancy of Steindal school was estimated for the different zones and the resulting total ventilation flow rates expressed in $l/s/m^2$ are shown in Figure 6 in white; in grey are the corresponding values for a maximum occupancy. The labels ‘TEK-’ refers to the Norwegian norm when considering low-emitting, normal and undocumented materials,

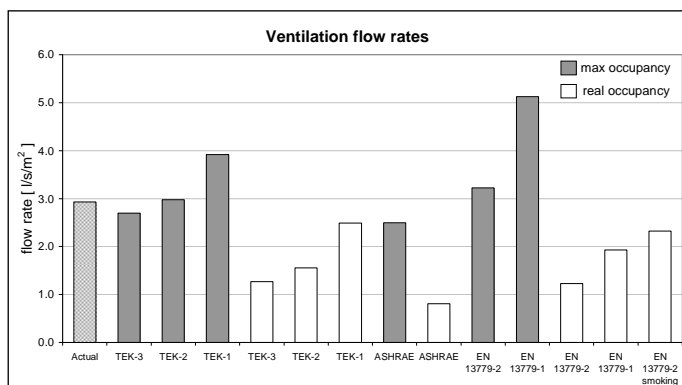

Figure 6: Various flow rates according with different codes and occupancy levels.

respectively. Results for other codes than the Norwegian are also shown for comparison. The American [ASHRAE, 1999] and the European [EN 13779, 2007] norms define their own reference levels of maximum occupancy; again, the graph shows resulting flow rates for both maximum and real occupancy. The European norm defines four levels of air quality; here only the highest two were considered, and they are labelled ‘-1’ for “very-good” air quality and ‘-2’ for “good” air quality. Generally a level ‘2’ is sufficient for both office and school spaces. It is worth noticing that the actual ventilation flow rate used in Steindal school, that roughly corresponds to a ‘TEK-2’ indication with maximum occupancy, is higher than the flow rate

prescribed by the European norm for a local of air quality level 2 (“good”) in presence of smokers (see “EN 13779-2 smoking” in Figure 6). The value chosen for the energy saving measures on the ventilation system is the ‘TEK-2’ with real occupancy data, meaning an average of $1.6 l/s/m^2$ corresponding to approx. $25\ 000 m^3/h$ for the entire building versus the today’s $46\ 000 m^3/h$. The value for the classrooms area is equivalent to $48 m^3/h/pers$ and is about the double than the value suggested in [Passivhaus-Schulen, 2006] and also reported by [Weiss et al., 2006], where monitoring projects of CO_2 concentration showed that a flow rate of about $15-25 m^3/h/pers$ is generally enough to meet (European) regulation requirements on air quality. Altogether the changes on the ventilation system bring the energy demand down to $107 kWh/m^2y$, which means in class C ($101-130 kWh/m^2y$) but close to reach the class B performance; in Figure 7 this is emphasized by the label “C+”.

Windows are an important building element in general, but especially for this school building where the entire north façade is covered by glazed area. Different types of windows are installed at the present in the building. The north façade of the main building still has the original old windows from 1978, and part of them (those operable) were being replaced in 2007, see Figure 1 b). Other windows in the south façade have been replaced in the meantime and windows in the annex are newer, from 1997. The U-value of installed windows and glazed areas varies from 3.3 to $1.9 W/m^2K$; corresponding estimated values of solar heat gain coefficient (g-value) and U-value for the frames are reported in Table 1. All windows and glazed surfaces are substituted with windows that satisfy the passive house criteria. They have a U-value of $0.8 W/m^2K$, insulated frame with U-value of $0.7 W/m^2K$ and g-value of 0.5 (e.g. a triple pane window with clear glass and double low-e coating). In addition, it is supposed that substituting the windows also the air tightness of the building results improved. In facts, it has been noticed during the works of substitution of some of the north face windows that the conjunction between wall and window frame was poor (e.g. loose and with no insulation at all along the frame’s perimeter). As a consequence it was estimated that by substituting the windows the infiltrations are reduced to a value of 0.1 air changes per hour (ach) in all zones, from the actual $0.1-0.3$ ach depending on the exposition of the zone. Finally, adopting high performing windows the temperature of the innermost pane increases, so that the difference between room air temperature and mean radiant temperature is small and the same operating temperature (the average of the two) can be achieved also with lower settings. Hence, room air temperatures are set to $20^\circ C$, and $18^\circ C$ during night and weekend, in all office and classroom zones. As an overall result the total energy demand gets down to $65 kWh/m^2y$, achieving the performance of a class A school building ($\leq 65 kWh/m^2y$).

Wall construction, for the major part, is made of two layers of brick encapsulating a layer of about 15 mm of mineral wool. Walls against ground in the storage rooms are made of concrete only, with a thickness of 50 cm. The roof is also insulated with mineral wool while the ground floor has only a perimeter insulation layer made of EPS. The corresponding U-values are reported in Table 1. For the intervention on insulation it is assumed that walls can be covered by cladding-on insulating blocks as those used in the renovation of the Schwanenstadt high school in Austria [Gasser and Plöderl, 2007]. Because the extra insulating layer is applied on the exterior

of walls, the thermal bridges on the wall constructions can be neglected. In the case of roof, ground floor and walls against ground, instead, additional internal insulation improves the structure's U-value but also presents thermal bridges. The thermal bridges are estimated according to [Hauser and Stiegel, 1994] and their values are reported in Table 1. Increasing the insulation of the envelope elements that are in contact with the ground also reduces the heat dispersed and in turn reduces the average temperature of the ground surrounding the building. The monthly average values for the ground temperature underneath the building are then changed from the initial 14-16°C to the 9-11°C after improving the envelope's insulation. Ground temperature values have been estimated using the software [PHPP 2007]. Again, the air tightness is assumed to improve due to the extra insulation and reach levels that comply with the passive house standard of 0.6 ach under a pressurisation of 50 Pa ($n_{50} \leq 0.6$ Pa with blower-door test). At normal operating conditions this value is assumed to correspond to infiltrations of $n = 0.05$ ach for all zones; the conversion between n_{50} and n is calculated according to [NS3031, 2007]. The effect on total energy demand is to reduce it down to 48 kWh/m²y, abundantly below the requirement for class A, and labelled in Figure 7 as "A+".

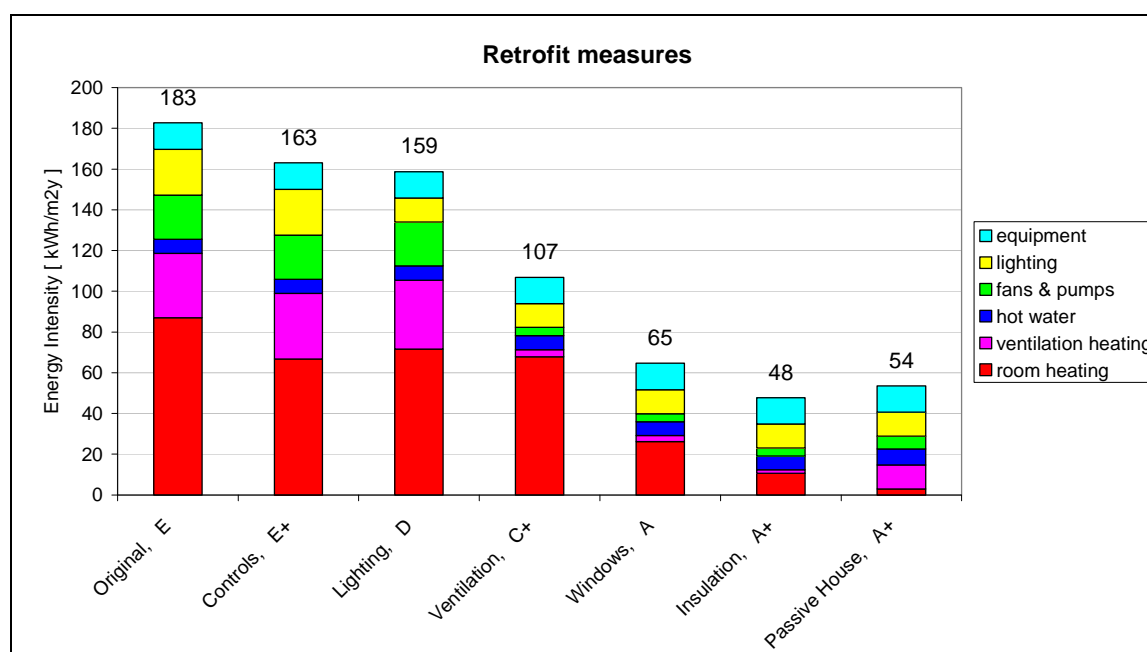

Figure 7: Cumulative effect of the retrofit measures.

With the implementation of extra insulating measures the goal of reducing heating demand to less than 15 kWh/m²y has been achieved; the sum of room and ventilation heating is actually 13 kWh/m²y in this case. Nevertheless, the requirement on total primary energy is not satisfied. The only energy carrier used in the school is electricity, and according with the German norm [DIN V 4701-10, 2003] the conversion factor from delivered to primary energy for electricity is 2.7. The figure would be different if a Norwegian conversion factor is used, since national production of electricity is almost entirely from hydropower, giving a conversion factor practically equal to the unity. Yet, the electricity market in Nordic countries is now unified in the NordPool power exchange and the tendency is to go toward a unified European electricity market. In this light it is more correct to adopt conversion factors that are valid in a broader context than Norway. Considering the total electricity demand of 48 kWh/m²y and adopting the German conversion factor of 2.7 the figure on primary energy results being 130 kWh/m²y, which is higher than the required limit of 120 kWh/m²y. To overcome this inconvenience it is possible to assume another energy carrier being used for heating purposes in the building. As an example it was chosen to use natural gas; even though a natural gas network is not developed in Norway the choice is justified for an exemplification case because natural gas has a conversion factor of 1.1 that is worse than other alternative carriers as district heating (0.8) or wood (0.2). In the "Passive House" measures, ventilation air becomes the prioritised source of heating (with an upper limit of 50°C in the supply air) while room electric radiators are used only to cover peak loads and to help preheating the locals after the weekends. The heating coil in the ventilation is now supplied by hot water from a gas boiler with an overall efficiency (including transmission losses) of 85%. Also the hot water for domestic purposes, as hot tap water in the kitchens and showering in the gym's showers, is produced by the gas boiler. Cooking is supposed to remain electricity based. Altogether the building requires now some more energy for heating (15 kWh/m²y) and also in

total (54 kWh/m²y) because of the lower efficiency of a gas based heating system. On the other hand, the energy used for ventilation heating (12 kWh/m²y) and for hot water preparation (8 kWh/m²y) is now converted into primary energy through a smaller factor. The total primary energy demand results in 114 kWh/m²y, and the definition of a passive house school building is then fully met.

References

- [ASHRAE, 1999] ASHRAE standard 62-1999, Ventilation for Acceptable Indoor Air Quality, *ASHRAE*, Atlanta, USA, 1999.
- [ASHRAE, 2002] ASHRAE Guideline 14-2002, Measurement of Energy and Demand Savings, *ASHRAE*, Atlanta, USA, 2002.
- [DIN V 4701-10, 2003] Energy efficiency of heating and ventilation systems in buildings - Part 10, Germany.
- [EN13779, 2007] EN 13779, Ventilation for non-residential buildings – Performance requirements for ventilation and room-conditioning systems, *CEN European Committee for Standardization*, Brussels, Belgium, 2007.
- [Energy Plus] <http://www.eere.energy.gov/buildings/energyplus/>
- [Gasser and Plöderl, 2007] Gasser B. and Plöderl H., Schwanenstadt sets an example, *Proceedings of the 11th International conference on passive houses 2007*, Bregenz, Austria.
- [Hauser and Stiegel, 1994] Hauser G. and Stiegel H., Wärmebrücken- Atlas für den Mauerwerksbau, *Bauverlag BV GmbH*, ISBN 3762530432, Germany, 1994.
- [NS3031, 2007] NS 3031:2007, Beregning av bygningers energiytelse – Metode og data, *Standard Norge*, Oslo, 2007.
- [Passivhaus-Schulen, 2006] Passivhaus-Schulen – Protokollband nr. 13, *Passiv Haus Institut*, Darmstadt, Germany.
- [PHPP, 2007] Passive House Planning Package – 2007 version, *Passiv Haus Institut*, Darmstadt, Germany.
- [Reddy and Maor, 2006] Reddy, T.A., Maor, I., Procedures for Reconciling Computer-Calculated Results With Measured Energy Data, *ASHRAE Research Project 1051-RP*, United States, 2006.
- [Sartori and Ricker, 2007] Sartori I. and Ricker E., Calibration of multiple energy simulations: case study on a Norwegian school building, *Proceedings of the CISBAT 2007*, Lausanne, Switzerland.
- [Steindal, 2006] Personal communication with teachers and technical and administrative personnel at the Steindal elementary school and at the remote control centre in the municipality, Trondheim, 2006.
- [TEK VEIL, 2007] Veiledning til teknisk forskrift til plan- og bygningsloven 1997 – 4. utgave mars 2007, *Statens Bygningstekniske Etat*, Oslo.
- [Weiss et al., 2006] Weiss W. and Jacob D., Operational experience in the passive house school in Waldshut, *Proceedings of the 10th International conference on passive houses 2006*, Hanover, Germany.
- [Wigenstad et al., 2005] Wigenstad, T., Dokka, T. H., Pettersen, T. D. and Myhre, L., Energimerking av næringsbygg, *Sintef Teknologi og samfunn – Arkitektur og byggeteknikk*, Trondheim, 2005.

Experience with the design process for almost passive houses for low cost housing in the extreme cold climates of North America: Lessons for Scandinavia?

David Benjamin, PhD, Sivilarkitekt, MNAL, LEED AP
Fridtjof Nansens Pl. 9, 0160 Oslo

Housing for the present Native American tribes of the Great Plains area presents several challenges to their housing authorities in providing durable, culturally relevant, low energy, and low cost shelter. Among these, the 5.500 degree days C heating demand, (comparable to Tromsø), for the northern part of this region presents a particular challenge to the effort of reaching highly energy efficient but low cost housing, let alone achieving the passivhaus standard. The non-profit Intertribal Council on Utility Policy received a USDOE grant to produce energy efficient and low cost housing designs to meet this need, for different family sizes. The design process produced three such houses from 2005 to 2006.

The author chose to develop these house designs through a combined process of design charettes and expert knowledge, (influenced by Gail Lindsey's guideline on high performance building design written for the DOE), which also included the conventional design iteration of architectural solutions. The charettes would help to ensure that cultural relevance and local knowledge would be integrated into the house designs and technology solutions while expert knowledge from practitioners in the fields of housing, architecture, and engineering would help to develop these ideas into buildings that would be low cost, (in terms of both first cost and operations), and durable.

The one bedroom straw bale house design is an interesting object of comparison for Scandinavia, both because it has the lowest U value for the building envelope and a compact, simple geometry to the volume, which should produce a relatively small heating demand in the modeling. The engineer chosen to consult on the heating, ventilation, plumbing, and energy modeling used a USDOE developed program called Energy 10, normally used for passive solar buildings. Despite the fact that there are more available sunny days in the northern Great Plains than Scandinavia, such that this program should have been appropriate, this program turned out to have difficulty in the logical data input to the model for both infiltration and the chosen heating/ventilation system. Further, there is still disagreement in the international literature concerning the correct U value to be used for both straw bales and for a plastered straw bale wall. Thus, the choice of engineering advice and modeling software seem to be critical for such projects that seek to extend the boundaries of conventional design within the latter part of Research, Design & Deployment activities. A new model run with the PHPP software on this house is now being carried out and will be presented at the conference.

Apparently, choices should be made early on in the design team selection and programming phases as to what consultants will be able to model desired outcomes and with which software. Further, a greater effort at the verification of material characteristics in the early stages of the process will in the future help to make quicker and better choices concerning the selection of critical components, such as insulation, including the use of Life Cycle Analysis and embedded energy analysis. These greater efforts will likely raise the price and slow down the design process. However, with more such examples of low energy housing designed and built, practitioners and the research community will be able to develop rules of thumb guidelines in the future to help in expediting the design process.

Session 12

Passive house components and solutions

Bengt Hellström

Impact of window properties on the heating demand of a passive house 312

Hans Martin Mathisen, Monica Berner, Johan Halvarsson, Sten Olaf

Hanssen

Behovsstyrt ventilasjon av passivhus – Forskriftskrav og brukerbehov 320

Matthias Haase, Inger Andresen, Berit Time, Tore Kvande, Anne Grete

Hestnes

Energy-efficient office buildings in Norway – from low energy standard to passive house standard 328

Inger Andresen, Klaus Ellehauge, Björn Karlsson, Jyri Nieminen

Solar heating systems for passive houses in the Nordic countries – An overview 336

Impact of window properties on the heating demand of a passive house

Bengt Hellström, Energy and Building Design, LTH, Lund University
P.O. Box 118, 221 00 Lund, e-mail: bengt.hellstrom@ebd.lth.se
Tel. +46 (0)46 222 73 58, Fax. +46 (0)46 222 47 19

Introduction

The aim of this paper is to derive relations that can be used for predicting the impact that changes in window properties have on the space heating demand (peak load and annual heating demand) of a passive house. Such predictions could be useful in the design phase of a planning process for a passive house. In this paper the consequences of changes in the following window properties are investigated:

- the g -value
- the U -value
- the window area
- the orientation

The study is made from simulations with the dynamic building simulation program DEROB-LTH [2006]. A house with overall properties similar to a passive house is used as a reference from which variations are made. Overheating problems are not considered in this study. In a planning process, however, the impact that a window parameter change will have on the thermal comfort must also be taken into account. The investigation is made for three different Nordic climates; Lund (55.43° N), Stockholm (59.20° N) and Luleå (65.33° N).

The inside geometry of the reference house is 10 m x 10 m x 2.5 m, which means that the floor area is 100 m² and the air volume is 250 m³. The heat loss through the floor in DEROB-LTH is calculated to the outside air, adding an extra heat resistance of the ground. This gives a floor U -value of 0.082 W/m²K, while the U -value of the external walls and roof are 0.102 W/m²K. The effective ventilation rate is set to 0.5 air exchanges per hour (around 0.35 l/sm²) with 80% heat recovery.

The outer walls and the roof of the reference house has a 5 mm sheet of gypsum inside the insulation, while the floor has a 45 mm slab of concrete beneath a 22 mm wooden top layer. Inner walls are not modelled.

The windows of the reference case have a total glazed area of 10 m², 4 m² for the south facade and 2 m² for each of the other three facades. The heights of the glazings are 1 m. The glazing portion of the window area is assumed to be 70 %, giving a window area of 14.3 m². Referring to the floor area, this corresponds to a specific glazed area of 0.10 and a specific window area of 0.143.

Values of U and g are calculated in DEROB-LTH as soon as a window type is selected, using boundary conditions of ISO 15099. The windows of the reference house have a g -value of 0.41 (referring to the glazed area) and a U -value of 0.88 W/m²K (referring to the window area).

The internal heat is set to 4 W/m² for the reference house and the total transmission and ventilation heat losses give an overall heat loss coefficient of around 0.50 W/m²K, counted on the floor area. The inside air is heated up to 21°C and cooled down to 26°C. The cooling is in the simulations used as a substitute for other means of preventing overheating, like using blinds and opening windows during summer. This was not necessary to model, since thermal comfort and cooling loads were not part of the study.

All parameter variations are made both with and without external solar shadings. The shadings, which are placed above the glazings, extend 1 m horizontally out from the windows, which means that the glazings are

fully shaded for solar altitudes above 45°. The shadings also extend 1 m on both sides of the windows. A graph of the reference building with solar shadings from DEROB-LTH is shown in Fig. 1.

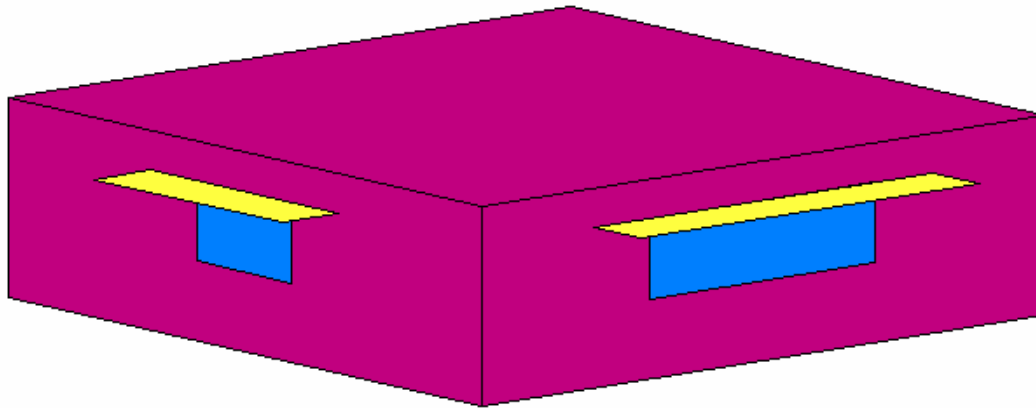

Fig. 1. Graph from DEROB-LTH of the reference house with external solar shadings.

Theoretical background

The specific net heat losses for the windows can, somewhat simplified, be written:

$$q_{ws} = A_f^{-1} \sum A_k (U_k (T_i - T_a) - F_k g_k G_k) \quad (1a)$$

where the summation is made for all the windows (index k) and

- q_{ws} = the specific net heat losses for the windows (W/m²)
- A_f = the floor area (m²)
- A_k = the area of window k (m²)
- U_k = the heat transfer coefficient of window k (W/m²K)
- T_i = the indoor temperature (°C)
- T_a = the outdoor (ambient) temperature (°C)
- F_k = the glazed fraction of window k (-)
- g_k = the total solar transmittance for the glazing of window k (-)
- G_k = the solar irradiance on the glazing of window k (W/m²)

By “specific” is here meant that the property refers to the floor area.

Eq. 1a can also be expressed:

$$q_{ws} = A_f^{-1} A_w (U_w (T_i - T_a) - F_g g_g G_g) \quad (1b)$$

where

- A_w = the total window area (m²)
- F_g = the average glazing fraction of the window area (m²)
- G_g = the average solar irradiance on the glazings (W/m²)
- g_g = the average total solar transmittance for the glazings (-)
- U_w = the average heat transfer coefficient for the windows (W/m²K)

or

$$q_{ws} = U_{ws} (T_i - T_a) - g_{gs} G_g \quad (1c)$$

where

$U_{ws} = A_{ws} U_w$ = the specific heat transfer coefficient for the windows (W/m²K)

$g_{gs} = A_{ws} F_g g_g$ = the specific total solar transmittance for the glazings (-)

$A_{ws} = A_f^{-1} A_w$ = the specific window area (-)

Integrating Eq. 1b over all hours of the year with a heating load gives the annual window heat losses, E_{ws} :

$$E_{ws} = A_{ws} (U_w H - F_g g_g Q_g) \quad (2)$$

where

E_{ws} = the annual window heat losses for all hours with a heating load (kKh/a)

H = the annual integration of $(T_i - T_a)$ for all hours with a heating load (kKh/a)

Q_g = the annual irradiation on the glazings for all hours with a heating load (kWh/m²a)

By differentiating Eq. 1b and Eq. 2 and approximating the differential equations as difference equations, theoretical expressions for the changes of the peak load, Δq_{ws} , and the annual heating demand, ΔE_{ws} , can be obtained. q_{ws} is part of the total space heating peak load, q_s , and E_{ws} is part of the total space heating demand, E_s . Δq_{ws} can therefore (somewhat simplified) be replaced by Δq_s and ΔE_{ws} by ΔE_s .

In this paper are the following expressions, Eq. 3a-5b, used to obtain the impact on the space heating peak load (Δq_s) and on the annual space heating demand (ΔE_s). Values of the change factors in the equations (within brackets) are derived from simulation results in the next chapter.

For changes in the U_w -value (with constant g_g and A_w):

$$\Delta q_s = (\Delta q_s / \Delta U_{ws}) \Delta U_{ws} \quad (3a)$$

$$\Delta E_s = (\Delta E_s / \Delta U_{ws}) \Delta U_{ws} \quad (3b)$$

For changes in the g_g -value (with constant U_w and A_w):

$$\Delta q_s = (\Delta q_s / \Delta g_{gs}) \Delta g_{gs} \quad (4a)$$

$$\Delta E_s = (\Delta E_s / \Delta g_{gs}) \Delta g_{gs} \quad (4b)$$

For changes in the A_w -value (with constant U_w and g_g):

$$\Delta q_s = (\Delta q_s / \Delta A_{ws}) \Delta A_{ws} \quad (5a)$$

$$\Delta E_s = (\Delta E_s / \Delta A_{ws}) \Delta A_{ws} \quad (5b)$$

where

q_s = the space heating peak load (W/m²)

E_s = the annual space heating demand (kWh/m²a)

Δq_s = change in q_s (W/m²)

ΔE_s = change in E_s (kWh/m²a)

$\Delta U_{ws} = A_{ws} \Delta U_w$

$\Delta g_{gs} = A_{ws} F_g \Delta g_g$

$\Delta A_{ws} = A_f^{-1} \Delta A_w$

Simulations

Simulations are performed with DEROB-LTH, using climate files for Lund, Stockholm and Luleå. The climate files were derived from the software Meteororm. In this chapter, only the simulation results for Lund are given, while the results for all of the three climates are given in the next chapter.

Simulations are made for different window U -values, keeping the g -value constant. The U_w -value of the reference case, $0.88 \text{ W/m}^2\text{K}$, was changed to $0.67 \text{ W/m}^2\text{K}$ and $1.34 \text{ W/m}^2\text{K}$. The results are shown in Table 1.

Window	U_w	g_g	U_{ws}	q_s	E_s	$\Delta q_s/\Delta U_{ws}$	$\Delta E_s/\Delta U_{ws}$	with solar shadings $\Delta E_s/\Delta U_{ws}$
	$\text{W/m}^2\text{K}$	-	$\text{W/m}^2\text{K}$	W/m^2	$\text{kWh/m}^2\text{a}$	K	kKh/a	kKh/a
Reference	0.882	0.414	0.126	10.5	16.3			
Low U	0.665	0.415	0.095	9.5	13.7	33	86	95
High U	1.337	0.413	0.191	12.6	22.1	32	89	95

Table 1. Simulation results from varying the U -value of the windows.

The change factor of the peak load for the reference house in Lund is around 33 K. This value is slightly lower than the difference between the indoor and the minimum outdoor temperature of the used climate file. For the annual heating demand, the change factor is around 86 kKh/a without and 95 kKh/a with the solar shadings.

Simulations are also made for different g -values of the glazings of the reference case. The g -value is changed from 0.41 to 0.54 and 0.67. Also a combination of a high g and a high U for the windows is tested. The results are shown in Table 2. The change factors are in this case negative since they represent solar gains from the window.

Window	U_w	g_g	g_{gs}	q_s	E_s	$\Delta q_s/\Delta g_{gs}$	$\Delta E_s/\Delta g_{gs}$	with solar shadings $\Delta E_s/\Delta g_{gs}$
	$\text{W/m}^2\text{K}$	-	-	W/m^2	$\text{kWh/m}^2\text{a}$	W/m^2	$\text{kWh/m}^2\text{a}$	$\text{kWh/m}^2\text{a}$
Reference	0.882	0.414	0.0414	10.5	16.3			
Medium g	0.882	0.541	0.0541	10.5	14.7	-3	-131	-115
High g	0.882	0.674	0.0674	10.4	13.3	-3	-117	-106
High g/U	1.337	0.688	0.0688	12.5	18.2	-3	-142	-119

Table 2. Simulation results from varying the g -value of the glazings.

The size (absolute value) of the change factor of the annual heating demand decreases somewhat if a higher g -value is chosen (from 131 to 117 $\text{kWh/m}^2\text{a}$). This is due to the fact that utilization of solar irradiation is limited by the net heating demand, caused by the heat losses. For the case of a higher U_w -value, the larger heat losses makes it possible to utilize more solar irradiation, which is shown as a larger (in size) change factor. The change factor vary slightly, depending on the conditions of the simulation. For the cases with external solar shadings, the change factors of the annual heating demand are somewhat smaller.

Increasing the total window area by e.g. 10 % would give a similar result as to increase both the U -value and the g -value by 10 % (differing mainly by the heat losses through the replaced wall area). The impact of a window area change (with preserved window orientation) could therefore be estimated from the previous results. It can, however, also be obtained from simulations of different window areas. Results of such simulations are shown in Table 3.

A_w/A_f	$F_g A_w/A_f$	U_{ws}	g_{gs}	q_s	E_s	$\Delta q_s/\Delta A_{ws}$	$\Delta E_s/\Delta A_{ws}$	with solar shadings $\Delta E_s/\Delta A_{ws}$
-	-	W/m ² K	-	W/m ²	kWh/m ²	W/m ²	kWh/m ² a	kWh/m ² a
0.000	0	0.000	0.0000	7.0	12.5			
0.071	0.05	0.063	0.0207	8.7	14.2			
0.143	0.10	0.126	0.0414	10.5	16.3			
0.214	0.15	0.189	0.0621	12.5	18.7	26	31	45
0.286	0.20	0.252	0.0828	14.4	21.1	26	30	45

Table 3. Simulation results from varying the window area with preserved window orientations.

The change factors are calculated from the difference between the 4:th and the 2:nd cases and also from the difference between the 5:th and 1:st case, giving almost the same result. The heating demand increases more with the window area if the windows have solar shadings.

Simulations were also made for different orientations of the building. From the results of the different building orientations and the different window areas, change factors for windows in different directions were calculated. The results are shown in Table 4.

Orientation	A_w/A_f	U_{ws}	g_{gs}	q_s	E_s	$\Delta q_s/\Delta A_{ws}$	$\Delta E_s/\Delta A_{ws}$	with solar shadings $\Delta E_s/\Delta A_{ws}$
	-	W/m ² K	-	W/m ²	kWh/m ² a	W/m ²	kWh/m ² a	kWh/m ² a
South	0.143	0.126	0.0414	10.5	16.3	26	11	32
West	0.143	0.126	0.0414	10.6	17.1	26	39	49
East	0.143	0.126	0.0414	10.6	17.2	27	41	51
North	0.143	0.126	0.0414	10.6	17.5	27	52	59
Average	0.143	0.126	0.0414	10.6	17.0	26	36	48

Table 4. Simulation results for different house orientations and window directions.

The reference house has a south orientation, meaning that the façade with the largest window area is facing south. The values of q_s and E_s in Table 4 are obtained for the different orientations of the reference house. The change factors in Table 4 are calculated for area changes of windows facing in the different directions.

The results from the simulations for all the climates (Lund, Stockholm and Luleå) are given in the next chapter.

In Fig. 2 and 3 duration diagrams of the space heating load is shown for different window sizes of the reference house in Lund. In Fig. 3, unlike in Fig. 2, the windows have external solar shadings.

The areas below the lines in Fig. 2 and Fig. 3 give the annual space heating demands. By taking the difference to the area below the line of 0 m² glazed area, the extra heating demand due to the window is obtained. It can be seen that all lines in the diagram intersect at approximately one point. For the hours to the left of this point, the outdoor temperature and irradiation conditions are such that an increase of the window size increases the heat load. Only for the hours to the right of the intersection point, the window has a positive impact and reduces the heating demand according to its size.

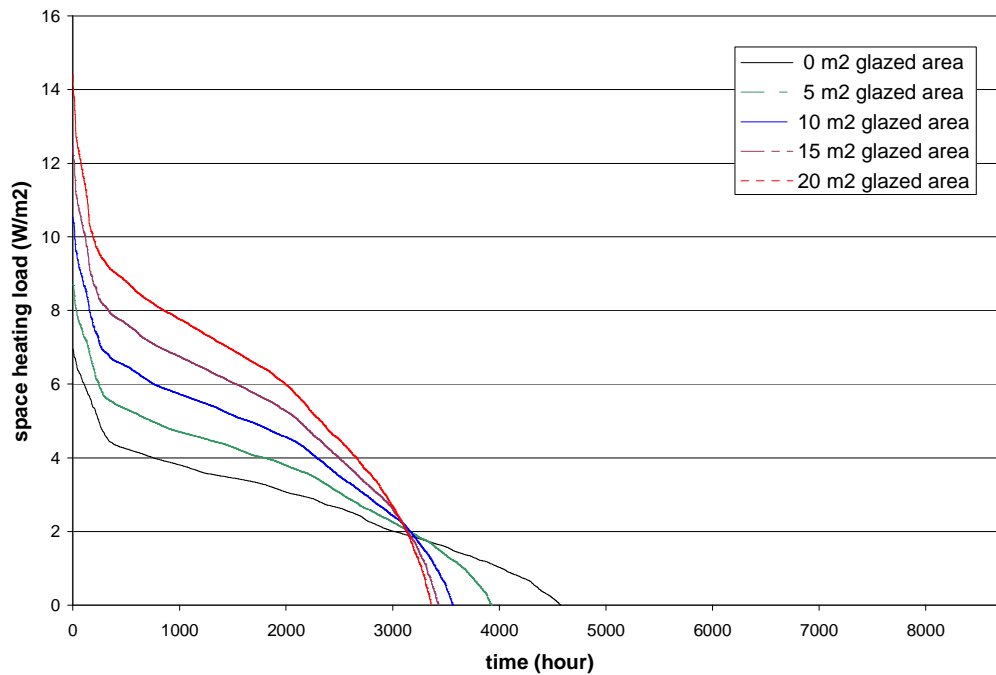

Fig. 2. Duration of space heating load for different window areas without solar shadings. The lowest line shows the case of 0 m² and the highest the case of 20 m² glazed area.

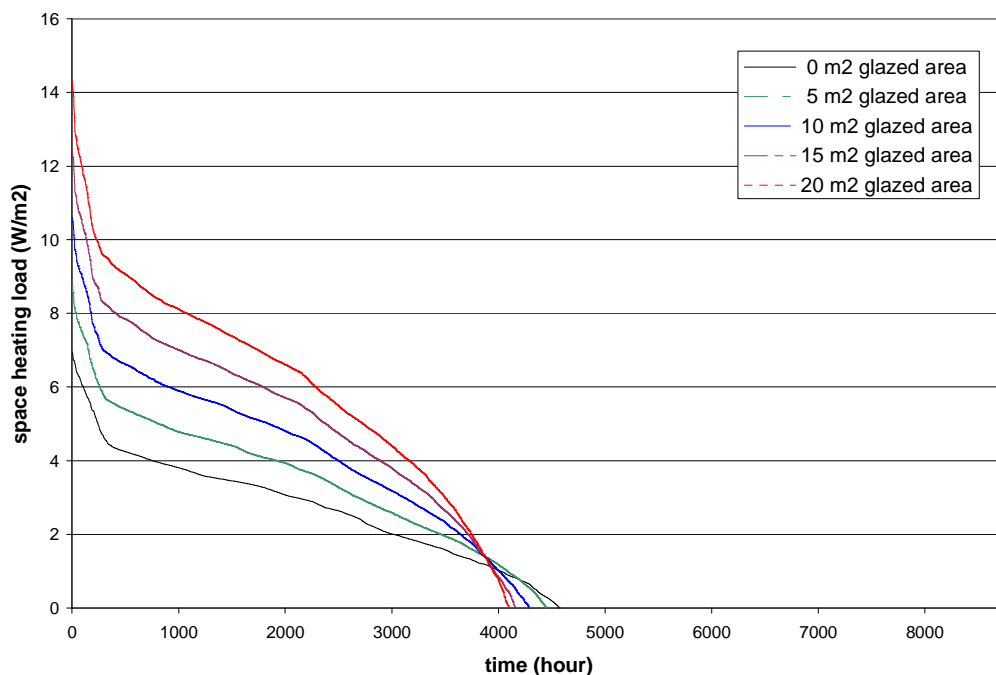

Fig. 3. Duration of space heating load for different window areas with external solar shadings. The lowest line shows the case of 0 m² and the highest the case of 20 m² glazed area.

In Fig. 4 the annual and peak space heating demands are shown as a function of window size for the reference house in Lund, with and without solar shadings. It can be seen that both the peak load and the annual heating demands increase approximately linearly with the window size.

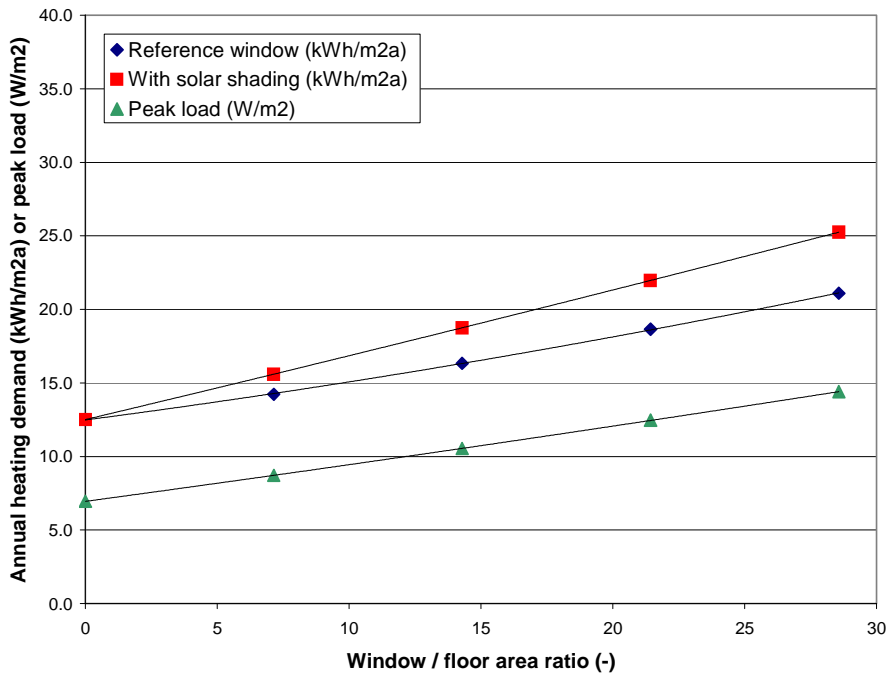

Fig. 4. Peak load and annual heating demands for the reference house in Lund with different window/floor area ratios with and without solar shadings.

Results

The resulting change factors of the peak load for different window parameters are for the climates of Lund, Stockholm and Luleå given in Table 5. The corresponding change factors of the annual heating demand are for windows with and without sunshades given in Table 6 and 7, respectively.

Climate	$\Delta q_s / \Delta U_{ws}$ K	$\Delta q_s / \Delta g_{gs}$ W/m ²	$\Delta q_s / \Delta A_{ws}$ south facade W/m ²	$\Delta q_s / \Delta A_{ws}$ west facade W/m ²	$\Delta q_s / \Delta A_{ws}$ east facade W/m ²	$\Delta q_s / \Delta A_{ws}$ north facade W/m ²
Lund	33	-3	26	26	26	26
Stockholm	37	-4	29	30	30	30
Luleå	42	-2	36	37	37	37

Table 5. Change factors of peak load for different window parameters

Climate	$\Delta E_s / \Delta U_{ws}$ kKh/a	$\Delta E_s / \Delta g_{gs}$ kWh/m ² a	$\Delta E_s / \Delta A_{ws}$ south facade kWh/m ² a	$\Delta E_s / \Delta A_{ws}$ west facade kWh/m ² a	$\Delta E_s / \Delta A_{ws}$ east facade kWh/m ² a	$\Delta E_s / \Delta A_{ws}$ north facade kWh/m ² a
Lund	86	-117	11	39	41	52
Stockholm	98	-134	12	50	47	62
Luleå	140	-156	36	78	69	95

Table 6. Change factors of annual heating demand for windows without solar shadings

Climate	$\Delta E_s/\Delta U_{ws}$ kKh/a	$\Delta E_s/\Delta g_{gs}$ kWh/m ² a	$\Delta E_s/\Delta A_{ws}$ south facade kWh/m ² a	$\Delta E_s/\Delta A_{ws}$ west facade kWh/m ² a	$\Delta E_s/\Delta A_{ws}$ east facade kWh/m ² a	$\Delta E_s/\Delta A_{ws}$ north facade kWh/m ² a
Lund	95	-106	32	49	51	59
Stockholm	107	-120	34	58	56	69
Luleå	144	-130	64	89	81	101

Table 7. Change factors of annual heating demand for windows with solar shadings

The derived values of Table 5-7 should be used with Eq. 3a-5b to calculate the changes of the peak load, Δq_s , and the annual heating demand, ΔE_s .

Some examples:

If the U -value of the windows of a passive house in Lund with a 70 % glazed window area of 15 m² and a floor area of 100 m² is increased by 0.1 W/m²K, this will give a change in the peak load of approximately

$$\Delta q_s = (\Delta q_s/\Delta U_{ws}) (A_w/A_f) \Delta U_w = 33 \text{ K} * 0.15 * 0.1 \text{ W/m}^2\text{K} \approx 0.5 \text{ W/m}^2$$

If the g -value of the glazings of the same building (without solar shadings) is increased by 0.1, this will give a change in the annual heating demand of approximately

$$\Delta E_s = (\Delta E_s/\Delta g_{gs}) (A_w/A_f) F_g \Delta g_g = -117 \text{ kWh/m}^2\text{a} * 0.15 * 0.7 * 0.1 \approx -1.2 \text{ kWh/m}^2\text{a}$$

If the window area on the south façade of the same building with external solar shadings is decreased by 1 m², this will give a change in the annual heating demand for the case with sunshades of approximately

$$\Delta E_s = (\Delta E_s/\Delta A_{ws}) \Delta A_w/A_f = 32 \text{ kWh/m}^2\text{a} * -0.01 \approx -0.3 \text{ kWh/m}^2\text{a}$$

Conclusions

Approximative formulas for calculating the impact of changes in window parameters, such as the U -value and the g -value, on the space heating energy performance of a passive house (peak load and annual heating demand) are derived. Also the impact from changes of the size of windows facing in different directions (south, north, west and east) are given. The formulas are derived for three different Nordic climates; Lund, Stockholm and Luleå. All investigations are made for two different cases of solar protection of windows; with and without external horizontal shadings.

References

[DEROB-LTH, 2006] v2.1 - 2006-01-18, Energy and Building Design, LTH, Lund University

Behovsstyrt ventilasjon av passivhus – Forskriftskrav og brukerbehov

Hans Martin Mathisen¹, Monica Berner^{1,2}, Johan Halvarsson², Sten Olaf Hanssen^{1,2}, ¹⁾ Sintef Energiforskning AS, ²⁾ Norges Teknisk Naturvitenskaplige Universitet (NTNU)

Sammendrag

Selv med effektiv varmegjenvinning gjenstår det et behov for energi til ettervarming og transport av ventilasjonsluften i boliger. En måte å redusere dette på er å benytte behovsstyring ved å tilpasse ventilasjonsluftmengden til det aktuelle/reelle behovet i hvert enkelt rom. Løsningen innebærer også en mulighet for å øke ventilasjonen ut over det normale i enkelte rom ved spesielle behov.

Det er noen forskjeller på kravnivået i Skandinavia, spesielt med hensyn til avtrekksluftmengder fra våtrom. Kravene tar ikke hensyn til verken rommenes størrelse eller belastning.

Nivåene for friskluftstilførsel er omtrent like når et bygg er i bruk. I Sverige er det tillatt med store reduksjoner i lufttilførselen når en bolig ikke er i bruk. For soverom kan de norske kravene være for lave til å sikre en tilfredsstillende luftkvalitet. Eksisterende regelverk bør revideres slik at ventileringen kan tilpasses aktivitetsnivå og at det kan unngås unødig ventilasjon når boligen ikke er i bruk.

Hvorfor skal bygninger ventileres

Ventilering, eller det å skifte ut luften i bygninger, gjøres i hovedsak ut fra to forhold. Det ene er å gi mennesker som oppholder seg innendørs en luftkvalitet som er mest mulig i samsvar med frisk uteluft. Det andre er å sikre bygget mot fukt og råteskader samt å opprettholde riktig trykksetting. En tredje årsak, som ofte ikke er så mye omtalt i boligsammenheng, er temperaturregulering.

Utsiktet ventilasjon i bygninger

I tidligere forskrifter og veiledninger ble det riktignok stilt krav til bygningenes tetthet, men kravet var såpass romslig at friskluft ble tilført gjennom utettheter og sprekker og i perioder utgjorde et betydelig bidrag til luftfornyelsen.

På grunn av det nye bygningsenergidirektivet (EPBD) har bygningsbestemmelsene blitt innskjerpet i Europa. Nye bygg samt lavenergi- og passivhus skal være langt tettere enn hus oppført etter tidligere lover, forskrifter og veiledninger. Dette innebærer at infiltrasjon og eksfiltrasjon, det vil si luftlekkasjene, er langt mindre enn i de fleste eksisterende bygninger. Infiltrasjonen påvirkes av trykkforholdene forårsaket av temperaturforskjellen mellom inne- og uteluft samt vindpåtrykk. I for eksempel et toetasjes bolighus vil bidraget fra infiltrasjon være lavt eller fraværende i andre etasje. Siden infiltrasjonen er lav og varierende med ytre forhold, kan man derfor ikke regne med noe bidrag fra infiltrasjon til luftfornytelse i nye hus.

Fuktavgivelse fra personer

En person i hvile avgir ca 0,03 kg fukt luft per time, mens det ved moderat aktivitet avgis 0,04-0,08 kg per time [Enøk i bygninger 2007]. Husstøvmidd er vanlig i norske boliger. Undersøkelser har vist at den trives best ved en relativ luftfuktighet på 60-70 %, mens den sjelden forekommer ved en relativ luftfuktighet under 40 %. [Mehl 1991] samt [Inneklimatelefonen 1991]. Med de fleste former for ventilasjon vil det være vanskelig å holde den relative luftfuktigheten under 40 % gjennom natten både på grunn av fukttilskuddet fra personer og fuktinnholdet i den tilførte luften, unntatt i vintermånedene.

Tverrvitenskapelige gjennomganger av den vitenskapelige litteraturen som omhandler fuktproblem og helse i bygninger ble gjennomført av en nordisk [Bornehag et al. 2001] og senere en europeisk ekspertgruppe [Bornehag et al. 2004]. Disse konkluderte med at fuktproblem i bygninger gir en økt risiko for helseproblem i

luftveiene, slik som hoste, astma og luftveisinfeksjoner og for allmennsymptom som slapphet og hodepine. Mekanismene bak denne sammenhengen er derimot ikke kjent. Eksponering for midd har vist seg å øke risikoen for sensibilisering og allergisk sykdom men kan ikke alene forklare alle helseproblemer. Hvilke indikatorer som har blitt brukt for å avgjøre om en bygning har fuktproblem eller ikke varierer mellom de ulike studiene.

Luktavgivelse fra mennesker

En frisklufttilførsel 7 l/s er angitt [Enøk i bygninger 2007] som tilstrekkelig for å opprettholde en tilfredsstillende luftkvalitet basert på sensoriske (lukt) forhold der mennesker er hovedforurensningskilden. Det tilsvarer omtrent frisklufttilførselen for å holde CO₂-konsentrasjonen under 1000 ppm, det vil si 0,1 volumprosent. Denne luftutskiftingen garanterer ikke nødvendigvis tilfredsstillende helsemessige forhold dersom det finnes andre helseskadelige forurensninger. Undersøkelser fra spesielt kontormiljø, som vanligvis har mindre volum per person har også kommet frem til at en lufttilførsel på ca 7 l/s per person vil være tilfredsstillende lufttilførsel i rom der mennesker er den dominerende luktprodusenten. For boliger anbefaler SINTEF Byggforsk 7 l/s [Blom 2000].

Inneklima og helse i nordiske boliger

Det er foretatt relativt få undersøkelser av inneklima i boliger, selv om vi oppholder oss langt mer i ulike boliger enn på arbeidsplassen. I prosjektet "Inneklimatelefonen" ble inneklima i utvalgte boliger i Trondheim, Hønefoss, Sarpsborg og Namsskogan undersøkt. Målingene viste store variasjoner i CO₂-konsentrasjon, som brukes som en indikator på luftens kvalitet der det er mennesker til stede. Spesielt i barnas soverom viste det seg at luftkvaliteten ble dårlig både på grunn av lite tilført luft og mengden leker og ting som finnes inne på barnerommene.

I en doktorgrad [Øie, 1998] ble 500 barn fulgt opp i over 2 år med hensyn til helseforhold samtidig som luftskiftemålinger ble utført i 172 boliger. Det ble funnet at 1/3 av boligene hadde et luftskifte på under en halv veksling per time. I boligene med lavt luftskifte er det vist at dette forsterker effekten av luftforurensninger innenfra. I tillegg ble det funnet en sammenheng mellom fuktskader og utvikling av bronkial obstruksjonen for barn fulgt fra 0-2 år. Likeledes ble det funnet en sammenheng med bruk av PVC gulv og bronkial obstruksjon. I en studie av svenske barn [Bornehag et al. 2004] ble det funnet en sammenheng mellom konsentrasjonen av ftalater (myknere), målt i støv i deres hjem, og allergiske symptom. Ftalater er en viktig komponent i blant annet PVC.

En europeisk ekspertgruppe gjennomførte en tverrvitenskapelig litteraturgjennomgang på sammenhengen mellom ventilasjon og helse, komfort og produktivitet i ikke-industrielle innemiljøer [Wargocki et al. 2002]. Det ble blant annet konkludert med at det er en mangel på studier som ser på sammenhengen mellom helse og ventilasjon i boliger. Litteraturen indikerer imidlertid at et luftskifte høyere enn 0,5 luftvekslinger per time reduserer omfanget av husstøvmidd. Med bakgrunn i påvist sammenheng mellom husstøvmidd og astma og allergi indikerer dette at redusert ventilasjon i boliger kan øke risikoen for allergier.

Regelverk i de skandinaviske land

Regelverket for boliger i Skandinavia er ikke sammenfallende, se Tabell 1. Svenske krav er angitt i byggreglens forskrift og tilhørende veiledning. Det samme gjelder for Danmark, mens de norske anbefalingene til luftmengder/luftskifte er angitt i veiledningsmateriell. Bakgrunnen for kravnivåene er vanskelig å fremskaffe, slik at det er vanskelig å vurdere om nivået er valgt ut fra skjønn, erfaringstall eller kun gjetting. Gjennomgangen av det skandinaviske regelverket viser relativt store forskjeller spesielt når det gjelder avtrekk fra våtrom.

En sammenligning av regelverk i 2005 [Halvarsson et al. 2005], med fokus på yrkes- og publikumsbygninger, viste at det også i denne bygningskategorien var et språk i kravnivå og veiledende verdier mellom de skandinaviske land. En forklaring til dette foreslås her å kunne være dels den usikkerhet som råder om ventilasjon, luftkvalitet og helse og dels ulikt politisk syn på balansen mellom energibruk og inneklima. Dette kan også for boliger være en delforklaring til at regelverket ikke er helt sammenfallende i Skandinavia. I tillegg kan bygningstekniske forskjeller spille inn.

Nordisk komité for bygningsbestemmelser (NKB) har tidligere publisert retningslinjer som skulle ligge til grunn for bygningsbestemmelser. I NKB-rapport nr 40 fra 1981 [NKB 1981] angis en minste luftveksling i boliger som helhet, men og i hvert enkelt rom for varig opphold, på 0,5 luftvekslinger per time. Denne retningslinjen var 1981 basert på hva som var kjent om emisjoner, fremst radon og formaldehyd, samt usikkerhet i øvrig på området. Det ble videre ansett som en rimelig verdi med hensyn på et fuktnivå som hindrer vekst av husstøvmidd og muggsopp. Fundamentet for dagens veiledning på 0,5 luftvekslinger/h kan det enda i dag settes spørsmålsteget ved siden vi fremdeles mangler kunnskap om sammenhengen mellom luftmengder og helseeffekter. I tillegg til dette er dagens bygninger både tettere og inneholder langt flere byggematerialer med større innhold av kjemiske stoffer enn tidligere.

I utgangspunkt er kravet til friskluftfornyelse omtrent likt på 0,35 l/s m² (for en bolig med takhøyde 2,5 meter vil en frisklufttilførsel på 0,35 l/s m² tilsvare en luftskifting på ca 0,5 ganger per time). Muligheten for behovsstyring er imidlertid svært ulikt beskrevet. I de svenske byggereglene er det nevnt at i boligblokker hvor ventilasjonen kan styres separat for hver enkelt bolig, kan ventilasjonssystemet utformes med behovsstyring. Sverige er de eneste som angir et krav på minimumslufttilførsel i de periodene en bolig ikke er i bruk (0,1 l/s m²). Sverige er dessuten alene om å stille krav til hvor effektivt ventilasjonen skal fjerne forurensninger, med et krav til en "air change efficiency" på minst 40 %. (Dette er noe dårligere friskluftsfordeling i rommet enn full omblending gir en "air change efficiency" på 50 %)

Tabell 1. Sammenligning av regelverk i Norge, Sverige og Danmark per 2008. "-" indikerer avtekk

Rom	Norge	Sverige ²⁾		Danmark ⁵⁾	
		Tilført luft, l/sm ²	Fra R1, l/s ³⁾	Krav	Avtrekk/tilluft cm ² ⁷⁾
Kjøkken	- 10 (30 ⁶⁾)		- 10	-20	200/100
Bad	- 15 (30 ⁶⁾)		- 10	-15 ⁵⁾	200/100
Toalett	- 10				200/100
beboelsesrom					Tilluftsventil på minst 30 cm ² per 25 m ²
Vaskerom/tørkerom ⁴⁾	- 10 (20 ⁶⁾)				200/100
Soverom			+ 4 per person		
Minimumsnivå		0,1 ¹⁾			
Luftskifte/ frisklufttilførsel	0.5 luftskifter per time	0,35		0,35 per m ² ⁴⁾ Ventiler minst 60 cm ² per 25 m ² boligflate ³⁾	

Merknader:

¹⁾Når ingen oppholder seg i rommet, 6:251, ²⁾I flerbostadshus kan ventilasjonen behovsstyres i boliger der ventilasjonen kan styres separat for hver boenhet. Etter en periode med redusert frisklufttilførsel bør rommet tilføres et luftskifte før det tas i bruk. ³⁾ Fra R1, tidligere råd om hygieneluftmengder, nå kun vedlegg i R1, Riktlinjer for spesifikasjon av inneklimatkrav. [R1 2006] ⁴⁾ Gjelder enkeltrom og boligen som helhet. ⁵⁾ For etasjebyggeri, dvs fleretasjes boliger og leiligheter i Danmark ble regelverket for småhus og større bygningskomplekser felles først 1.1.2008. ⁶⁾ Gjelder dersom rommet ikke har vindu. ⁷⁾ Gjelder for naturlig ventilasjon

Utfordringer ved bruk av behovsstyrt ventilasjon

Siden regelverkene er så vidt sprikende og inneholder muligheter for fortolkning burde det vært utført sammenliknende målinger for ulike boligtyper og for ulike bruksmønstre. Ut fra romvolum per person og en risikovurdering betraktes soverom og våtrom/bad som de mest kritiske rommene. For å få en viss formening om forholdene i nybygde boliger er det utført målinger over en periode på 9 dager i tre leiligheter, bygd etter den norske plan- og bygningsloven av 1997.

Målinger av temperatur og fuktighet i tre leiligheter sommeren 2007

Atferd og bruksmåte og dermed energibruk vil variere mye selv mellom like leiligheter. For å få mer kunnskap om fuktforhold og temperatur i eksisterende boliger ble det sommeren 2007 foretatt målinger i tre nybygde leiligheter som alle bebos av to yngre personer, se Figur 1. Målingene ble primært foretatt for å fremskaffe opplysninger om spesielt fuktbelastning i soverom og på badet.

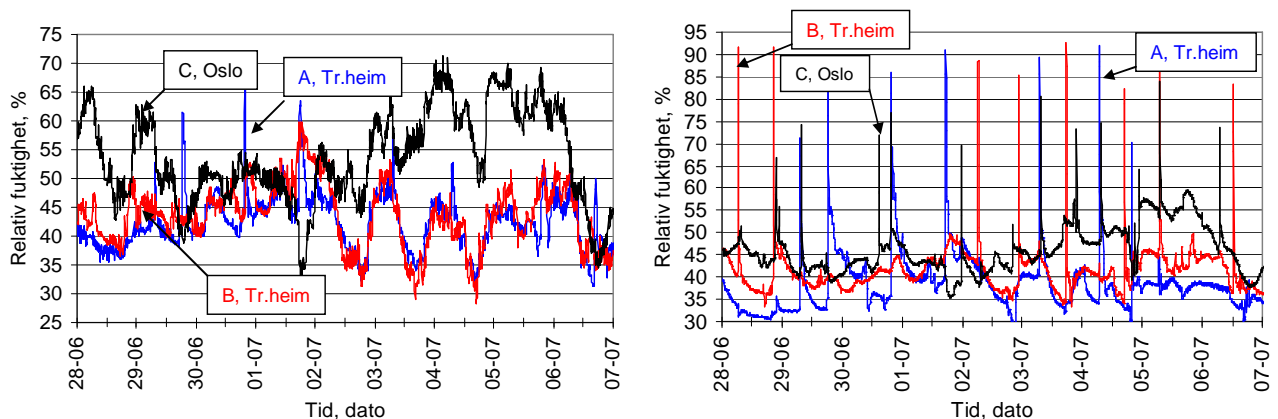

Figur 1. Måling av relativ luftfuktighet i soverom og bad. Boligene A og B har mekanisk avtrekksventilasjon mens bolig C har mekanisk balansert ventilasjon. Relativ fuktighet i soverom i venstre figur og relativ fuktighet i bad i høyre figur. Fra [Dromnes 2007]

Målingene viser store svingninger over døgnet. I leilighet C varierer relativ fuktighet i soverom fra 33 til 70 % i måleperioden, mens den i leilighet A varierer fra 28 til 60 %. Leilighet B har tilsvarende svingning som i A.

I badet varierer relativ fuktighet fra 35 til 84 % i leilighet C og fra 30 til 92 % i leilighet A. Variasjonen er omtrent tilsvarende i leilighet B som A. I badet i leilighet C går det raskere å komme ned til normalnivå. Tiden det tar før normalnivå nås er sannsynligvis en vesentlig faktor for risiko for utvikling av fuktskader. Det er også foretatt måling av temperaturen på baderommene, disse er langt mer stabile enn fuktigheten.

For baderommet ser vi at periodene med høy fuktighet er kortvarige, Det betyr at dersom man styrte luftmengden etter fuktigheten eller bruken av badet kunne det oppnås store reduksjoner i luftmengden. For soverommene er det også stor variasjon i fuktbelastningen, men her må ventilasjonen også vurderes i forhold til andre faktorer som luftkvalitet og vekstforhold for husstøvmidd. I neste kapittel er det gjort noen teoretiske beregninger av fuktvariasjon i baderom.

I soverom er det nødvendig med ytterligere undersøkelser for å trekke konklusjoner siden både tilstedeværelse og luftevaner varierer mye.

Eksempel, energibruk og fuktbelastning i passivhus

Tabell 2 viser beregnet fordeling av energibruk i et passivhus. Det er forutsatt kontinuerlig drift av ventilasjon hele døgnet og med luftmengder i henhold til norske forskrifter og veiledninger. Som det går fram av tabellen så står ventilasjon for den vesentligste delen av energibruken til oppvarming og ventilasjon. Elektrisitet til drift av vifter står for nesten 30 % av energien til ventilasjon. Dersom ventilasjonen ble bedre tilpasset brukerbehovet så kunne energi til oppvarming av ventilasjonsluft og elektrisitet til drift av vifter reduseres vesentlig.

Tabell 2. Eksempel på fordeling av energibruk i passivhus, varmegjenvinner med 70 % virkningsgrad.

Total årlig, kWh/m ² år	66.6
Oppvarming, kWh/m ² år	3.6
Ventilasjon totalt, inklusive vifter, kWh/m² år	14.4
Ventilasjon (ettervarme og oppvarming i rom), kWh/m ² år	10.4
Vifter, kWh/m ² år	4

I mange leiligheter er det kravet til avtrekk fra våtrom som blir bestemmende for ventilasjonsluftmengden. Figur 2 og Figur 3 viser resultater av en forenklet beregning av relativ fuktighet ved dusjing i et badrom. Beregningene er utført for å illustrere sammenhengen mellom vandamp tilførsel fra dusjing, rommets volum, ventilasjonsluftmengden og ventilasjonens effektivitet.

Dersom romtemperaturen er lik temperaturen på flatene i rommet vil det når relativ fuktighet når 100 % være stor fare for at vandamp kondenserer på rommets flater. Er flatene kjøligere enn romluften vil kondensering skje ved lavere relativ fuktighet enn 100 %. Beregningene viser hvordan relativ fuktighet øker når det tilføres en konstant mengde vandamp til luften, og hvordan relativ fuktighet avtar etter at damp tilførselen opphører. Det er ikke tatt hensyn til at det må fordampes vann fra fuktige flater etter at dusjingen opphører. Det forutsettes også at romlufttemperaturen holder seg konstant og at det er full omrøring/lik konsentrasjon av vandamp i hele rommet.

Som det går fram av Figur 2 oppstår det kondensering etter ca fem minutter ved en luftmengde på 15 l/s. Dobling av luftmengden til 30 l/s gir lite økning i tiden før kondensering oppstår. Utlufting av fuktighet skjer hurtigere når luftmengden dobles. Ved å halvere dampmengden dobles tiden før kondensering oppstår, se høyre del av figuren. Dette tilsvarer at ventilasjonens effektivitet (egentlig "contaminant removal effectiveness" [Mundt 2004]) bedres ved at ikke all vandamp fra dusjen sirkuleres i rommet, men strømmer direkte til ventilasjonsutsuget.

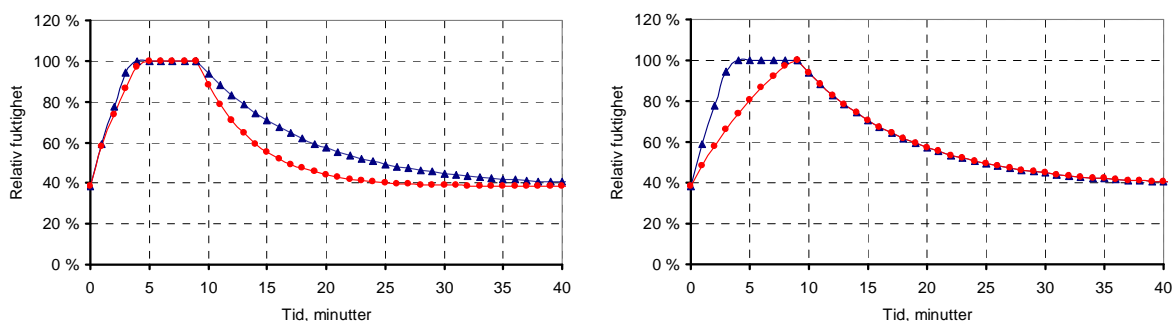

Figur 2. Beregnet relativ fuktighet som funksjon av tid i badrom ved dusjing. Rommets areal er 3.7 m². I venstre del av figuren viser kurve med trekantede 15 l/s i lufttilførsel og kurve med prikkede 30 l/s. I høyre del av figuren viser kurve med trekantede normal fukttilførsel og kurve med prikkede representerer halvert fukttilførsel. Lufttilførselen er i dette tilfellet 15 l/s.

Figur 3 viser en sammenligning av et lite og et stort baderom med lik tilførsel av vanndamp ved dusjing. I det store rommet gjør volumet og det derav følgende lavere luftskiftet at den relative fuktigheten stiger langsommere og avtar langsommere enn i det minste rommet. Ved å doble luftmengden i det store rommet økes uttynningshastigheten slik at fjernes omtrent med samme hastighet som i det minste rommet.

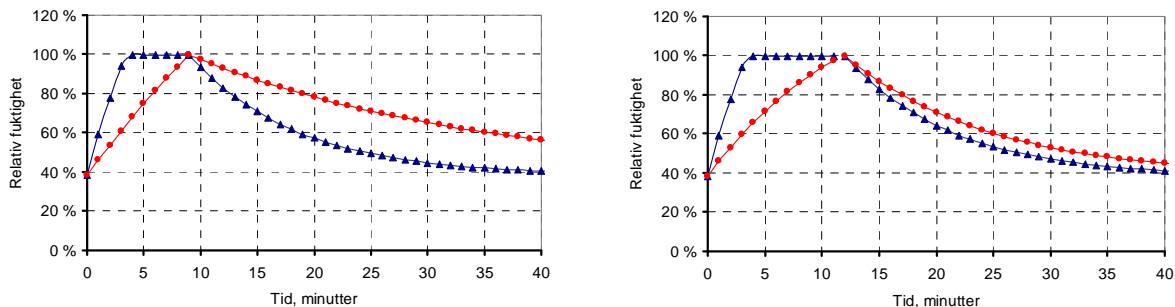

Figur 3. Beregning av relativ fuktighet som funksjon av tid i baderom ved dusjing. Lite bad på 3.7 m² sammenlignet med større bad på 10 m². Venstre del av figuren viser lite bad på 3.7 m² (kurve med trekkanter) sammenlignet med større bad på 10 m² (kurve med prikker). 15 l/s i lufttilførsel til begge rom. Høyre del av figuren viser 15 l/s i lufttilførsel til lite bad (kurve med trekkanter) og 30 l/s til stort bad (kurve med prikker).

Med hensyn til kondensering i rommet er det mer effektivt å fjerne fuktigheten før den slipper ut i rommet enn å øke luftmengden. Norske veiledninger relaterer ikke luftmengden til rommets størrelse eller hvor effektivt ventilasjonen fjerner fuktighet. Effektivitet kan for eksempel bedres ved å bruke dusjkabinett eller dusjhjørne med dører og å plassere avtrekket over dusj. Ved å utnytte muligheten til å fjerne vanndampen før det slipper ut i romluften, kunne luftmengden reduseres betydelig i forhold til anbefalingen i veiledningen. Forskrift og veiledninger burde derfor relatere luftmengde til rommets størrelse og ventilasjonseffektivitet.

Diskusjon

Gjennomgangen av det skandinaviske regelverket viser relativt store forskjeller spesielt når det gjelder avtrekk fra våtrom. I utgangspunkt er kravet til friskluftfornyelse omtrent likt på 0,35 l/s m², men muligheten for behovsstyring er svært ulikt beskrevet.

Målingene fra 3 leiligheter viser store forskjeller mellom dem, spesielt mht relativ luftfuktighet i soverom og på bad. Nivået påvirkes riktignok av uteluftforholdene og aktivitetsnivået, i tillegg til selve ventilasjonsløsningen og ventilasjonseffektiviteten. Leilighetene er alle oppført i henhold til den norske plan- og bygningsloven fra 1997.

Simuleringene av et våtrom viser betydelige forskjeller mellom resulterende luftfuktighet og tiden det tar å nå et tilfredsstillende fuktignivå. Det norske og danske kravet til konstant avtrekksluftmengde uten at det er tatt hensyn til rommets størrelse synes urimelig.

Ved passivhus og lavenergihus utgjør energi til drift av ventilasjonsanlegg og oppvarming av luft en større prosentandel enn romoppvarmingen. Energien til viftedrift er elektrisk og kan vanskelig erstattes av andre fornybare energikilder. Ved bruk av behovsstyring vil energibruken både til viftedrift og oppvarming av ventilasjonsluft kunne reduseres betraktelig, uten at det går på bekostning av inneklimate og øker risikoen for bygningstekniske skader.

Konklusjon

Gjennomgang av regelverk og veiledninger for de Skandinaviske land viser noe inkonsistent veiledninger vedrørende krav til luftmengde. Med utgangspunkt i lovverkets intensjon; å skaffe et tilfredsstillende inneklima og bevare bygget, vil det likevel være mulig å utprøve ulike alternativer for behovsstyring. Dette vil kanskje ikke redusere energibruken vesentlig i det enkelte bygg, men utgjøre en prosentvis stor andel av energibruken i et passivhus, samtidig som inneklimaet bedres ved at luften til enhver tid tilføres der det er størst behov for dette.

Siden regelverket er så vidt uhensiktsmessig i forhold til belastning burde det vært revidert. For små leiligheter og små bad vil kravet til avtrekksluftmengde kunne være unødvendig høyt. Det norske kravet til luftskifte på 0,5 luftvekslinger per time for boligen som helhet sikrer ikke tilfredsstillende luftkvalitet i alle oppholdsrom, noe som kan anses spesielt kritisk på soverom.

Det er nå stort fokus på energiutnyttelse i boliger. For å hindre negative effekter på helse, trivsel og bygning, bør det nå i Norge og andre land, i lys av ny kunnskap og byggemetode, settes fokus på å oppdatere minimumskrav til ventilasjon av ulike romtyper. Dette kan bidra til både bedre boliger og lavere energibruk.

I denne sammenheng vil standarden NS-EN 15251 "Inneklimaparametere for dimensjonering og vurdering av bygningers energiytelse inkludert inneluftkvalitet, temperatur, belysning og akustikk" være et hensiktsmessig hjelpemiddel fordi man her ivaretar kravene til inneklima samtidig som energidirektivets mål om god energiytelse sikres.

Takk for bidrag

Utarbeidelse av denne artikkelen er muliggjort blant annet gjennom økonomisk bistand (kompetansetilskudd) fra Husbanken. Mastergradsstudent Ingrid M. Dromnes har bistått med innsamling av måledata.

Referanser

C.-G. Bornehag, G. Blomquist, F. Gyntelberg, B. Järholm, P. Malmberg, L. Nordvall, A. Nielsen, G. Pershagen, J. Sundell (2001) Dampness in Buildings and Health. Nordic Interdisciplinary Review of the Scientific Evidence on Associations between Exposure to "Dampness" in Buildings and Health Effects (NORDDAMP), Indoor Air 11 (2)

C. G. Bornehag, J. Sundell, S. Bonini, A. Custovic, P. Malmberg, S. Skerfving, T. Sigsgaard, A. Verhoeff (2004) Dampness in buildings as a risk factor for health effects, EUROEXPO: a multidisciplinary review of the literature (1998-2000) on dampness and mite exposure in buildings and health effects, Indoor Air 14 (4) , 243–257

P Wargocki, J Sundell, W Bischof, G Brundrett, P. O Fanger, F Gyntelberg, S. O Hanssen, P Harrison, A Pickering, O Seppänen, P Wouters (2002) Ventilation and health in non-industrial indoor environments: report from a European Multidisciplinary Scientific Consensus Meeting (EUROVEN), Indoor Air 12 (2) , 113–128

Enøk i bygninger – Effektiv energibruk, Gyldendal Norsk Forlag AS, Oslo, 2007

Den nordiske komité for bygningsbestemmelser, Innomhusklimat, NKB-rapport nr 40, Mai 1981

Øie, Leif, The role of indoor building characteristics as exposure indicators and risk factors for development of bronchial obstruction in early childhood, Doktor ingeniøravhandling 1998:51, NTNU, juni 1998

Mundt, E., Mathisen, H.M., Nielsen, P.V., Moser, A., Ventilation effectiveness, Rehva guidebook No 2, 2004

Prosjektkurs Inneklimatelefonen kommunehelsetjeneste og fylkeslegenivå, Åsgårdsstrand 2-6. sept 1991

Halvarsson, J., Hanssen, S.O., Mathisen, H.M., Rationale for IAQ regulations i Scandinavia – Similarities and differences, pp: 3459-3463, Proceedings Indoor Air 2005, Beijing

Blom, P., Byggedetaljblad 421.510, Tilrettelegging fo godt innemiljø I boliger, SINTEF Byggforsk, 2000

R1, Riktlinjer för specifikation av inneklimatekrav, 2006

Mehl, R., Personlig meddelelse, Folkehelsa, 1991

Dromnes, I. M., Behovsstyring av ventilasjon i lavenergiboliger, passivhus og blokkbebyggelse, Prosjektoppgave, Rapportnummer 11, EPT-P-2007-Nr 11, NTNU 2007

Energy-efficient office buildings in Norway – from low energy standard to passive house standard

Matthias Haase¹, Inger Andresen¹, Berit Time¹, Tore Kvande¹, and Anne Grete Hestnes²

¹ SINTEF Building and Infrastructure, Alfred Getz vei 3, 7465 Trondheim

² NTNU, Faculty of Architecture and Fine Arts, Alfred Getz vei 3, 7491 Trondheim

Introduction

More efficient use of energy in the built environment is essential to reach political goals within Norway and the European Union on reliable energy supply and reductions of emissions of greenhouse gases. The built environment affects nature through energy use, emissions and use of raw materials. The total energy use in buildings accounts for about 40% of the total energy use in the country, excluding the energy sectors (Statistics Norway 2006). The construction industry may thus make significant contributions to environmental improvement through energy efficiency and utilization of renewable energy.

In order to realize energy performance requirements of a higher standard in the new Technical Regulations, it is necessary to develop new design strategies to meet these requirements - without sacrifices in other performance codes, standards or guidelines. Prior experience related to the introduction of new energy performance requirements has shown that the design energy performance levels are either not met, or they are fulfilled at the expense of indoor climate, technical quality (e.g. moisture related problems), or architectural quality. Facing the future risks of climate change, Norway also provides a unique “laboratory” for testing of the robustness of new building envelope solutions [Lisø 2005].

Therefore it seems appropriate to determine the parameters of building design that have the biggest influence on energy consumption of buildings. This work is a part of the Norwegian project entitled Climate Adapted Buildings (CAB) that runs from 2007-2009 and is financed by the Norwegian Research Council. Special focus has been put on the building envelope and some parameters that have an influence on the building load [Andresen 2005]. The starting point was to focus on office buildings but other building types will be studied in the near future.

Energy efficiency

There is no official definition of specific goals and figures for low energy buildings. Some attempts have been made to define a low-energy building. In Germany, the lean building has been defined with specific primary energy consumption of 100 kWh/(m²a) [Voss 2006]. The new energy labelling system will help to categorize the levels of energy use in buildings [Wigenstad 2005].

New technical building code (TEK07)

The national building regulations in Norway have been revised and tightened several times since the first numerical requirements were introduced in 1949. The purpose of the recurrent upgrades has basically been to reduce the heating energy demand, thus reducing the overall energy use in the building.

As a consequence of the Norwegian partnership in the EEC, Norway is obliged to implement the EU Energy Performance of Buildings Directive in the national laws and regulations. Thus, the new building codes and guidelines are also revised. While the former regulations concerned building's heating energy demand, the new regulations incorporate all energy needed to operate the building.

According to the new code, there are two ways to fulfill the new energy regulations for a building.

- (a) Energy measure method (Energiltak)
- (b) energy frame method (Energirammer)

The so-called Energy measure method (Energiltak) sets requirements to certain building elements and installations. The “measures” are listed in Table 1.

TABLE. 1: The new building regulations for commercial and residential buildings

	TEK 2007	
	commercial	residential
Glass and door area ^a	20 %	20 %
U-value external wall (W/m ² K)	0.18	0.18
U-value roof (W/m ² K)	0.13	0.13
U-value floor on ground (W/m ² K)	0.15	0.15
U-value windows and doors ^b (W/m ² K)	1.20	1.20
U-value glazed walls and roofs (W/m ² K)	same as for windows	same as for windows
normalized thermal bridge value (W/m ²)	0.06	0.03
air tightness ^c (ach)	1.5	2.5
heat recovery ^d (%)	70	70
specific fan power (SFP) (kW/(m ³ /s))	2.0/1.0 ^e	2.5
local cooling	shall be avoided ^f	shall be avoided ^f
temperature control	night set-back to 19°C	night set-back to 19°C

Notes: ^a maximum percentage of the buildings heated floor area as defined in NS3031

^b incl. frames

^c air changes per hour at 50Pa pressure

^d annual mean temperature efficiency

^e SFP day/night

^f automatic sun shading devices or other measures should be used to fulfill the thermal comfort requirements without use of local cooling equipment

Alternatively, if the net energy demand for the building, calculated according to the methodology established in the new Norwegian Standard NS3031: 2007, is within the energy frame for the building’s category, the regulations are also satisfied [NS3031]. The frame for aggregate net energy demand for office buildings is 165 kWh/m² (heated floor area)^a /yr. Since the frame is based on net specific energy demand per year, the efficiencies of the energy systems are not taken into account. This means that for example the coefficient of performance of a highly efficient mechanical cooling system is not rewarded. However, passive measures that reduce the net cooling demand will contribute to satisfy the energy frame. This puts an extra focus on utilizing passive measures to decrease the total energy use in buildings.

However, the code still contains minimum requirements concerning the U-values and air tightness of the building envelope which help to maintain a good insulation standard. These are listed in Table 2.

TABLE. 2: Minimum insulation requirements

	usual buildings
U-value external wall (W/m ² K) ^a	0.22
U-value roof (W/m ² K)	0.18
U-value floor on ground (W/m ² K)	0.18
U-value windows and doors ^b (W/m ² K)	1.60
air tightness ^c (ach)	3.0

Notes: ^a maximum percentage of the buildings heated floor area as defined in NS3031

^b incl. frames

^c air changes per hour at 50Pa pressure

Passive house standard in office buildings

Particularly in the residential sector other standards like the passive house standard have become widely used [PHI 2004]. Although the passive house standard is well defined in residential buildings in Germany there is still no official definition for Nordic countries [Dokka 2006a]. In addition, there exist some difficulties to implement this standard to other building types, like office buildings due to differences in internal heat loads and occupation hours.

Objectives

The principal objectives of the CAB project are to develop more energy-efficient building envelope assemblies and new methods for the design of building envelopes in harsh climates, resulting in more accurate and geographically dependent design guidelines. The project includes analyses of building envelopes applied in different kinds of climates, different uses, and different construction methods.

Nine energy-efficient office buildings in Norway were studied in order to get an overview of the state-of-the-art of low energy office buildings in Norway. This paper includes a description and classification of the energy concepts and the corresponding technologies for reducing energy consumption in the buildings. Then, the implications of these technologies are studied with the help of a simulation model and the key issues that influence the energy performance of these buildings with special emphasis on envelope performance are reported. Building design parameter which are most sensitive to changes were then changed in order to develop passive houses.

Methodology

For a typical energy efficient office building the following parameters are studied:

- Air tightness of the building envelope (typically ach, or n50 infiltration)
- Thermal insulation of the building envelope (U-values of floor, roof, and walls)
- Windows/glazing type, size and orientation (U-values of windows (incl. frame))
- Efficiency of heat recovery system

The total energy consumption is simulated for three different construction standards and the results are compared. First, the Norwegian standard from 1997 that formed the basis for most of the nine case studies was simulated and the resulting energy savings of special construction details are shown. Then, the resulting energy savings of the revised Norwegian regulations [TEK 2007] are calculated. Finally, the passive house standard is applied to a typical office building and the resulting energy savings are shown.

All simulations were done with SCIAQ [Dokka and Dokka 2004], a dynamic simulation software that calculates annual energy consumption (AEC) for heating, cooling, lighting and equipment. It is based on hourly weather data that were provided by the Norwegian Meteorological Institute [MET 2006]. Although the software has been validated the simulation results have been compared with measured data in order to get confidence in the simulation results (ProgramByggerne ANS 2004).

Results

Survey of existing energy efficient office buildings

The survey of existing energy efficient office buildings identified nine projects that are summarized in Table 3. Detailed information was collected and compared [Haase 2008b]. The energy systems of these projects were categorized according to [Dokka 2006] and results are shown in Table 5.

Table 6 shows the annual energy consumption for the different projects. Most numbers are estimated energy performances; the numbers for the Bravida building (and other buildings as indicated in Table 5) are based on monitoring results. Here, it can be seen that the annual energy consumption is between 80 kWh/(m²a) (Telenor Kokstad) and 160 kWh/(m²a) (Røstad). This has been divided into energy consumption for heating, service hot water and electricity use, where data could be found. The amount of energy used for heating varies between 23 kWh/(m²a) (Vestveien) and 111 kWh/(m²a) (Røstad). For most projects the electricity consumption is the largest portion. It ranges between 47 kWh/(m²a) (Nydalspynten) and 85 kWh/(m²a) (MMS Horten).

TABLE. 3: List of projects that have been considered in survey

Name	Location	T(mean)	Client /Developer	Architect	Energy Engineerin g	Completi on year
Bravida	Fredrikstad	6.4 °C	Høyenhold Invest AS	Multiconsult AS	Norsk Energi	2003
Hamar Rådhus	Hamar	4.1 °C	Hamar Kommune	Snøhetta AS	-	2001
Miljøsent er Blindern	Oslo-Blindern	5.7 °C	Miljøforsknings senteret ANS	Niels Torp as Arkitekter MNAL	Hambra	2006
MMS Horten	Horten	6.6 °C	Statsbygg	Kristiansen & Bernhard Arkitekter AS	-	1996
Nydalspynten	Oslo	5.7 °C	Avantor	Niels Torp Arkitekter AS	SINTEF	2008
Røstad	Levanger	4.7 °C	Statsbygg	Letnes Arkitektkontor AS	Interconsult Group ASA	2002
Sig. Halvorsen	Sandnes	7.3 °C	Sig. Halvorsen	-	-	2006
Telenor Kokstad	Bergen	7.8 °C	Telenor Eiendom	Pedersen / Ege Arkitekter AS	Vest Consult / OFE AS	2000
Vestveien	Ski	5.4 °C	Knut A. Jacobsen AS	h. arkitektiner AS	SINTEF	2008

The electricity consumption is further split into cooling, fan&pumps, lighting, and equipment. In 2 projects no electricity is used for cooling (Nydalspynten and Vestveien). Electricity consumption for equipment varies between 23 kWh/(m²a) (Miljøsent er Blindern) and 34 kWh/(m²a) (Vestveien). The Vestveien project uses electricity consumption for equipment as required in the new NS 3031:2007 while the other projects used older versions to calculate electricity consumption. Electricity consumption for lighting ranges between 17 kWh/(m²a) and 27 kWh/(m²a). Electricity consumption for fan&pump ranges between 6 kWh/(m²a) (Vestveien) and 32 kWh/(m²a) (MMS Horten). No detailed data were available for Bravida, Hamar Rådhus, Røstad, Sig. Halvorsen, and Telenor Kokstad.

TABLE. 4: Classification (Category 1 to 4) for different energy systems

Category	Technology	Bravida	Hamar Rådhus	Miljøsent er Blindern	MMS Horten	Nydalspynten	Røstad	Sig. Halvorsen	Telenor Kokstad	Vestveien
1	double-façade ¹ superwindow	X	X	X		X			X	X
2	double-façade ¹ earth coupling heat pump hybrid ventilation passive cooling PV-roof biomass thermal collector	X	X	X	X	X	X	X	X	X
3	demand control ²	X		X		X				
4	district heat			X					X	

Notes: ¹ Category of double-skin facade depends on control strategy of airflow (Category 1 if it reduces energy demand; Category 2 if it utilizes solar energy)

² Demand control can also reduce energy consumption (Category 2) but usually gives feedback on energy use (Category 4)

TABLE. 5: Annual energy consumption in kWh/(m²a) and its share

Building	Total	Electricity split						
		Heating	Hot water	Electricity total	cooling	fan&pump	lighting	equipment
Bravida	(100)							
Hamar Rådhus	?							
Miljøsender Blindern	119	35	10	74	4	20	27	23
MMS Horten	123 (105,3)	32	6	85	7	32	22	24
Nydalspynten	84	32	5	47	0	4	15	28
Røstad	(161,45)							
Sig. Halvorsen	100			(50,09)				
Telenor Kokstad	(80)							
Vestveien	85	23	5	57	0	6	17	34

Notes: Numbers in brackets refer to measured data, other numbers are design/simulation data; numbers in italic are electricity split (sum is shown in column 'Electricity total')
No data for Hamar rådhus were available

Simulation results

The Bravida building was chosen for further detailed simulation as shown in image 1. The 3-storey building is located in Fredrikstad, Norway (latitude 59.2°N, longitude 10.5°E), 116m long and 18.1m wide and comprises 6300m² heated floor area. The construction of internal structure consists of medium weight furniture, medium weight partition construction with a thermal capacity of 12 Wh/m²K. Occupied hours are from Mon. to Fri.- 0800 to 1600 hr, Sat. and Sun. and Easter and Christmas holidays-closed. The characteristics of the HVAC system are described in Table 6.

TABLE. 6: HVAC system characteristics of simulated building

	Airflow / capacity	Type / set point temp.	Operating hours
(a) Ventilation	Minimum 3.6 m ³ /hm ² ; maximum 10 m ³ /hm ² - Throttling range = 1 °C	HVAC system type = VAV Ventilation	0600 hr to 1800 hr
(b) Heating	capacity: 50 W/m ² ; convective share delivered heating: 0.5	Heating set point temperature 22 °C during operating hours (20 °C outside operating hours)	0600 hr to 1800 hr
(c) Cooling	capacity: 40 W/m ² ; convective share delivered heating: 0.5	Cooling set point temperature 26 °C (off outside operating hours)	0600 hr to 1800 hr



image 1 Bravida building east facade

For this building nine input parameter were changed within a range and the corresponding changes in output were calculated. The results are shown in image 2 together with a table of the input parameters. The first two rows give the min/max input values, the following rows show the input parameter for 3 different building 'standards'. It can be seen that the climate has the largest output range (65kWh/(m²a)) followed by the air tightness of the building envelope (36kWh/(m²a)), the efficiency of the heat recovery system (30kWh/(m²a)), the WFR (27kWh/(m²a)) and the U-value of the window (14kWh/(m²a)). The other input parameter changes show small changes in output range. The orientation of the building was not sensitive to changes and is therefore not included in image 2.

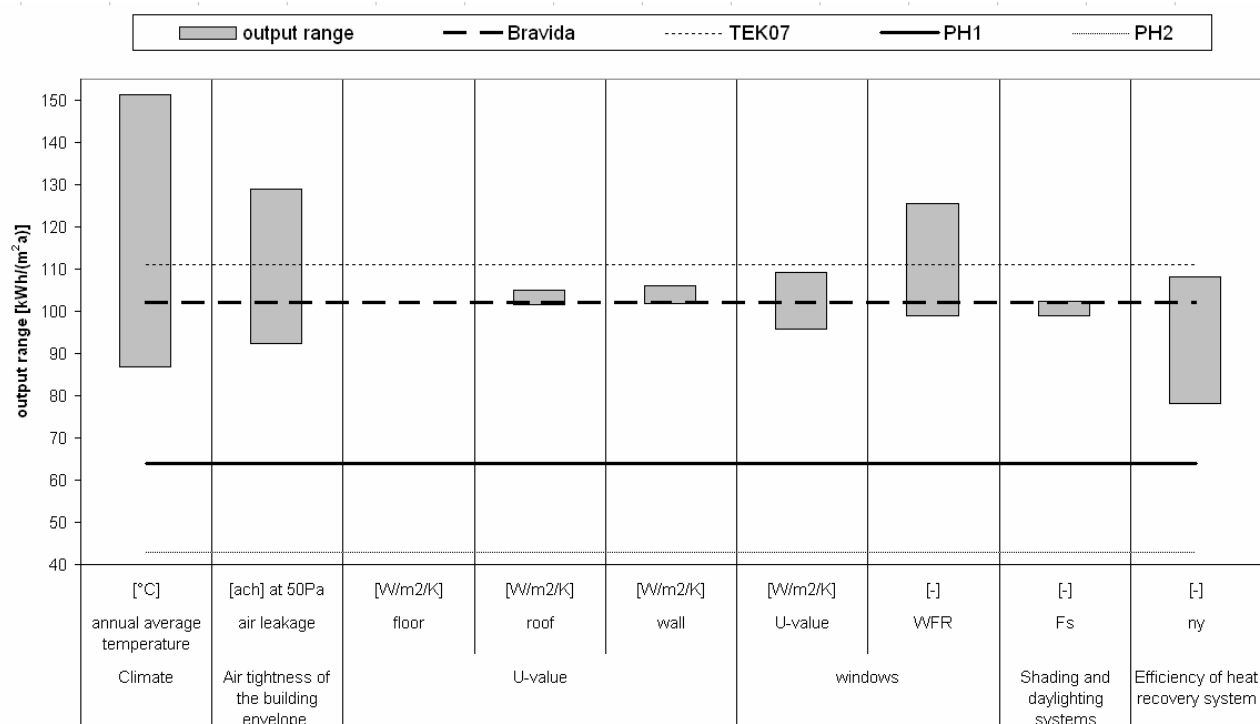

max input value	7,8	5,714	0,2	0,25	0,3	2	0,3927	1	0,9
min input value	4,7	0,357	0,1	0,15	0,15	0,8	0,0873	0,4	0,55
Bravida Input	6,4	2,14	0,2	0,2	0,2	1,4	0,1309	0,5	0,6
TEK07 Input	5,7	1,50	0,15	0,13	0,18	1,2	0,1745	0,5	0,7
PH1 Input	6,4	0,60	0,15	0,13	0,18	1,2	0,1745	0,5	0,85
PH2 Input	6,4	0,60	0,1	0,1	0,15	0,8	0,1309	1	0,85

image 2 Sensitivity analysis and simulation inputs

The sensitivity of the input parameters gives a good indication with respect to which parameters should be handled with care, and this forms a basis for developing further low energy buildings. This is demonstrated in the following. First, the Bravida building was simulated and compared to measured data [Haase 2008a]. Then, the new TEK07 office building standard was simulated. Input data are shown in image 1 and in Table 1. Finally, 2 different buildings with passive house standard were simulated and results are shown in image 3.

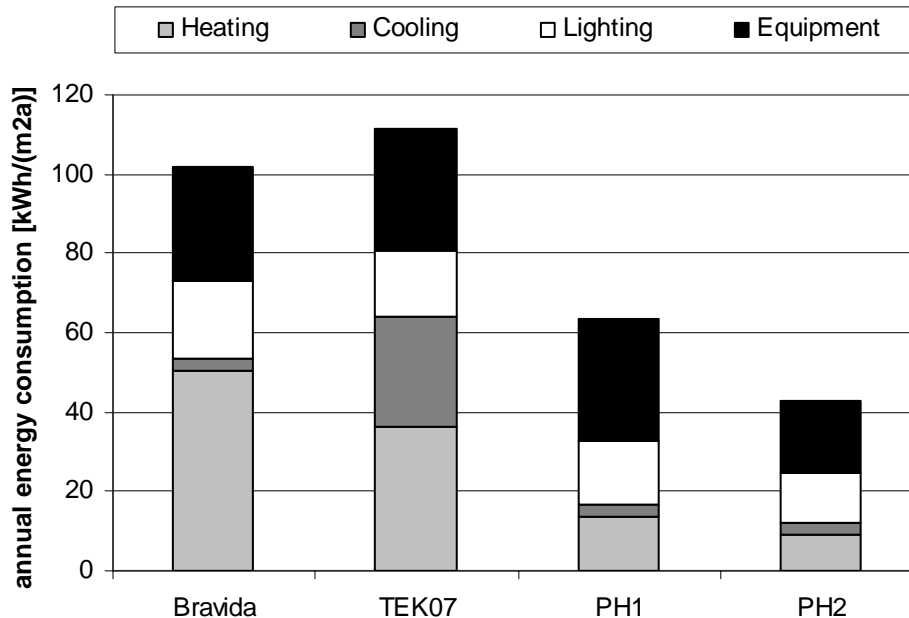

image 3 Simulation results

The results shown in image 3 illustrate

- The Bravida building is a low-energy building with an annual energy consumption of 102 kWh/(m²a) simulated with climate data for that location (Meteonorm data set for Rygge).
- The same building calculated according to the new TEK07 standard its annual energy consumption increases to 111 kWh/(m²a). Here, the climate data for Oslo has been used as required in new regulation [TEK 2007]. The energy consumption for heating decreases to 36 kWh/(m²a) (39%), while energy consumption for cooling increases to 28 kWh/(m²a) (89%) mainly due to reduction of the cooling set-point temperature to $t = 22^{\circ}\text{C}$.
- The passive house standard (air leakage of 0.6 (ach); heat recovery efficiency of 85%) applied to the Bravida building (PH1), calculated for the real location reduces the annual energy consumption to 64 kWh/(m²a). Heating energy consumption is reduced to 13.5 kWh/(m²a).
- In PH2, further reduction of annual energy consumption to 43 kWh/(m²a) is possible by further reducing U-values of the building envelope (to 0.15 W/(m²K) for walls and 0.1 W/(m²K) for floor and roof), reducing WFR (to 0.1309), and reducing internal loads for lighting and equipment (to 6 and 5 W/m² respectively).
-

Conclusions

The results show that significant efforts are needed in order to bring Norwegian office buildings up to the passive house standard. In particular, significant improvements of construction details regarding insulation levels and air tightness of the envelope are needed. Also, efficient heat recovery systems are crucial. A careful design of climate adapted and super-efficient envelope systems can further enhance energy robustness, energy efficiency and comfort.

Limitations and further work

The sensitivity analysis of the input parameter shows good results for the Bravida building only. The next step would be to analyze the sensitivity of input parameter for other building types and standards. Especially the

revised Norwegian building standard (TEK 2007) defines different sets of minimum input parameter that will change the input range and presumably the output range. Further sensitivity analysis can help to indicate potential for further energy reduction in the built environment.

References

- [Andresen 2005] Andresen, Aschehoug, Bell, and Thyholt, Energy-Efficient Intelligent Facades. A state-of-the-Art. *Sintef Report* No. STF50 A05021, ISBN 82-14-03559-7. (2005)
- [Dokka 2004] Dokka and Dokka, SCIAQ Pro – Simulation of Climate and IndoorAir Quality. (2004)
- [Dokka 2006a] Dokka and Andresen, Passive Houses in cold Norwegian climate, proceedings of the 10th International passive house conference (2006)
- [Dokka 2006b] Dokka and Hermstad, *Energieffektive boliger for fremtiden – En håndbok for planlegging av passivhus og lavenergiboliger*, SINTEF Buildings and Infrastructure, Trondheim. (2006)
- [Haase 2008a] Haase and Andresen, Key issues in energy-efficient building envelopes of Norwegian office buildings, proceedings of the Nordic Symposium on Building Physics, Copenhagen, to be published (2008)
- [Haase 2008b] Haase and Andresen, State-of-the-art of sustainable energy-efficient building envelopes in Norwegian office buildings, proceedings of the Sustainable Building conference (SB08), Melbourne, Australia, to be published (2008)
- [Lisø 2005] Lisø, Kvande, and Thue, Climate 2000—building enclosure performance in a more severe climate. In: Jo` hannesson G, editor. *Proceedings of the seventh symposium on building physics in the Nordic Countries*. Reykjavik: the Icelandic Building Research Institute p. 211–8. (2005)
- [NS3031] Norsk Standard NS 3031: 2007, Calculation of energy performance of buildings – Method and data, Standard Norge (2007).
- [PB 2004] ProgramByggerne ANS, User Guide SCIAQ version 2.0. (2004)
- [PHI 2004] The Passive House institute, *PHPP 2004: Passive House Planning Package 2004*, Passive Haus Institut, www.passiv.de. (2004)
- [TEK 2007] Statens Bygningstekniske Etat, *Energi – Temaveiledning*, HO-1/2007, ISSN 0802-9598, Norsk Byggtjenestes Forlag, Oslo (2007)
- [Voss 2006] Voss, Loehnert, Herkel, Wagner, and Wambsganss, *Buerogebaeude mit Zukunft*, ISBN-10: 3-934595-59-6, p. 37-41, Solarpraxis, Karlsruhe (2006)
- [Wigenstad 2005] Wigenstad, Dokka, Pettersen, and Myhre, *Energimerking av næringsbygg*, SINTEF rapport STF50F05117, (2005)

Solar heating systems for passive houses in the Nordic countries – An overview

Inger Andresen¹, Klaus Ellehauge², Björn Karlsson³ and Jyri Nieminen⁴

¹SINTEF Building and Infrastructure, Norway, inger.andresen@sintef.no

²Ellehauge & Kildemoes, Denmark, klaus.ellehauge@elle-kilde.dk

³Lund University, Sweden, bjorn.karlsson@ebd.lth.se

⁴VTT, Finland, jyri.nieminen@vtt.fi

Introduction

Due to the very low space heating energy demand in passive houses, the energy demand for domestic hot water is becoming a dominant part of the total energy use of such houses. Thus, several passive house projects have incorporated solar energy systems to reduce the need for auxiliary energy for domestic hot water heating. This paper gives an overview of some of the solar heating systems installed in Nordic passive houses, including system layout, design issues, performance data (where available), and lessons learned.

Overview of projects

Table 1 shows an overview of the 9 projects included in this paper.

Name of project	Location	Ta °C	Ihor kWh/m ²	Collector brand/supplier	Aabs	Vs	fs	References
Lindås Park	Lindås, Sverige	8.4	963	Effecta	20 x 5 m ²	20 x 500 l	50% of DWH	[Boström et al 2003]
Oxtorget	Varnamo, Sverige	8.4	963	Effecta	3 x 25 m ²	3 x 2000 l	50% of DWH	www.oxtorget.se [Wall 2008] [Jansson 2008]
Kungsbacka	Frillesås, Sverige	5.3	963	Derome	52 m ²		50% of DWH	[Wall 2008] [Jansson 2008]
Rønne-bækhave II	Næstved, Danmark	8.1	1018	ArCon solvarme	28 m ²	8 x 240 l	60% of DWH	[Cenergia 2006]
Langenkamp one family house	Ebeltoft, Danmark	7.7	1018	Wagner	7.8 m ²	500 litres	60% of DWH	http://www.altompassivhuse.dk/31-eksempler-fr.html
IEA5 solar house	Pietarsaari Finland	3.0	874	NAPS Systems	10 m ²	3000 l	35% of DWH and 5% of SH	[Hestnes et al 1997]
Løvåshagen	Bergen, Norway	7.8	760	Apricus, Skjølberg energiteknikk	28 x 4 m ²	28 x 300 l	40% of DWH and 5% of SH	www.solkraft.no www.bybo.no
I-Box	Tromsø, Norway	3.0	635	Vitosol, Viessmann	4.1 m ²	250 litres	50% of DWH	www.passivhus.no
NorOne	Sørumsand, Norway	5.7	983	Westech, Huhnseal	2.4 m ²	500 litres	40% of DWH	www.norone.info

Ta = yearly mean ambient temperature, Ihor = yearly total horizontal radiation, Aabs = total absorber area (of the collector), Vs = storage volume, fs= solar fraction – design values, DWH = Domestic Hot Water, SH = Space Heating

Table 1. Overview of solar heating systems in Nordic Passive houses.

Lindås Park, Göteborg, Sverige



Figure 1. Passive houses at Lindås Park with solar collectors at the roof. Photo: Inger Andresen.

The passive houses at Lindås Park outside Göteborg were constructed in 2001 and encompass 20 apartments of about 120 m² each. Each apartment has an individual solar heating system with solar collectors placed on the roof and a DHW tank placed in the bathrooms. The solar collectors are Effecta ST flat plate collectors with a selective absorber and a cover of tempered diffusing glass. The heat transfer medium is glycol base and can withstand temperatures down to -30°C. Each apartment has two solar modules with a total effective absorber area of 5 m². The collectors are integrated into the roof that has a tilt of 27 degrees and is oriented almost due south (4 degrees east). The DHW tank has a volume of 500 litres and has 2 internal heat exchanges (one for solar heat and one for DHW) and an electric heater of 6 kW.

The cost of the system was SEK 44,000 including DHW tank and installation [Boström et al 2003]. In the design phase, the performance of the solar system was simulated with the computer program MINSUN. The system was estimated to cover about 50% of the DHW load. The performance of the solar system and the domestic hot water usage was measured for 4 apartments, see figure 2. The hot water demand varied between 500 and 2200 kWh/year, and the average solar fraction was about 37%.

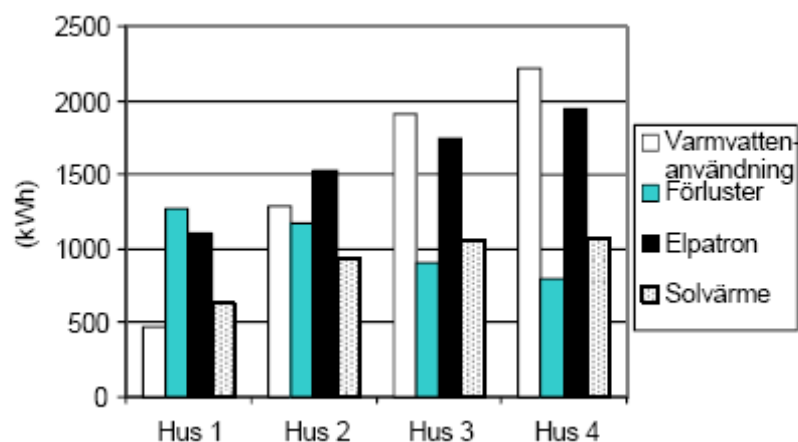

Figure 2. Measured yearly hot water demand, heat losses from tank and pipes, and energy yield from the electric heating element and the solar collectors for 4 apartments in Lindås Park, from [Boström et al 2003].

Oxtorget, Värnamo, Sweden

The Oxtorget project consists of 3 row houses constructed during 2005-2006 and contains 40 apartments. The houses have flat-plate solar collectors installed in the south facing roof. Each house has a total of 25 m² of solar collectors coupled to a central storage tank in each building. Auxiliary DHW heating is supplied by an electric battery in the storage tank. The hot water storage consists of two tanks. When the solar collectors are not in use, cold water is going into tank 1 and continues into tank 2, where the water is heated to 65°C. Before going out to the tap water system, the heated water is mixed with cold water to 60°C. When the sun is shining and the sensor in the solar collector indicates a 3-4°C higher temperature level than the temperature in the first tank, the pumps for the solar system start. Water mixed with glycol circulates and is heat exchanged to the domestic hot water system. The hot water passes to tank 1 and after that, to tank 2 and is heated to 65°C. If the temperature of the water has reached 65°C, it will go directly to heater 2 [Janson 2008].

The DHW use was measured from Aug-06 to Aug-07. to about 2 m³/apartment per month. The yearly total auxiliary energy for DHW heating was measured to 14 kWh/m²/yr (electricity), [Wall 2008].



Figure 3. Passive houses at Värnamo with solar collectors at the roof. Photo: Ulla Janson.

Kungsbacka, Frillesås, Sweden

The passive house project at Frillesås contains 12 apartments in 3 row houses. The project, which was completed in 2006, has a common 52 m² solar collector system located on the roof of a separate building which also contains storage tank and other equipment (see figure 4). The domestic hot water is heated to 60°C. Circulating hot water is used for the heating battery in the ventilation units and it also runs through a small heating coil in the bathroom floors. These heating coils have a temperature of approximately 35°C and are cast in the bathroom floors to give additional comfort. The water runs in the coil all year round and can not be turned off by the tenants because of the risk of Legionella. When the temperature sensor in the solar collector system exceeds 30°C, the solar system starts to heat domestic hot water. The liquid in the solar collectors goes in to a heat exchanger, heating water for the domestic system. The pump starts when the temperature difference between the liquid at the top of the water tank and on the solar side of the heat exchanger is at least 5°C. Additional cold water is mixed with the solar heated water to reach the temperature level of 60°C. Auxiliary heating is supplied by district heating [Janson 2008].

The solar system is estimated to cover about 50% of the DHW load [LTH 2007]. The DHW load was estimated to 25 kWh/m²/yr, while the space heating was estimated to 16 kWh/m²/yr.



Figure 4. Passive houses at Frillesås with technical house containing solar heating system. Photo: Inger Andresen.

Rønnebækhave II, Næstved, Denmark



Figure 5. South facing facade of the Rønnebækhave house. Photo: Cenergia.

The passive house at Rønnebækhave is a 2-storey house with 8 apartments. The solar heating system consists of 28 m² flat-plate collectors from Arcon, coupled to individual DHW tanks in each apartment. Each of the 8 DHW tanks has a volume of 240 litres, and is equipped with 2 internal heat exchangers and n electric heating element. The lower heat exchanger is coupled to the solar collectors and covers 1/3 of the tank. The middle 1/3 of the tank is covered by a heat exchanger coupled to a heat pump. The upper 1/3 of the tank is heated by an electric heating element. The solar system covers about 60% of the domestic hot water need.

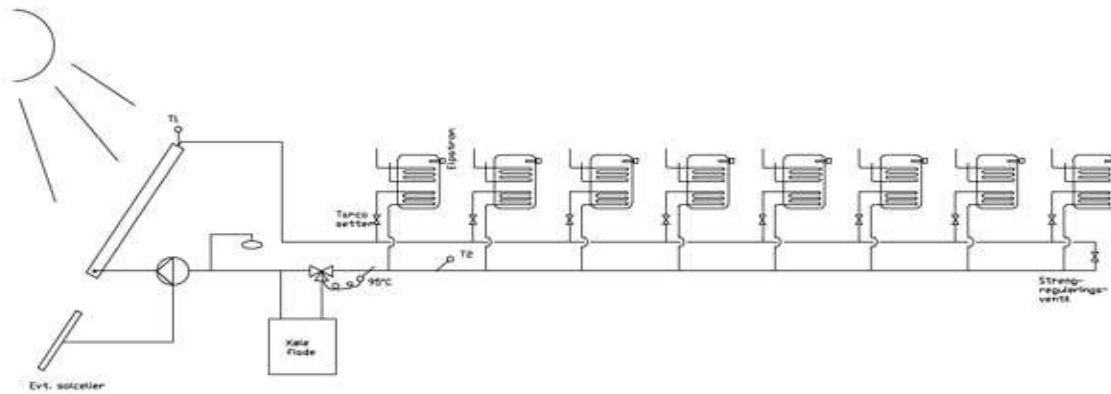
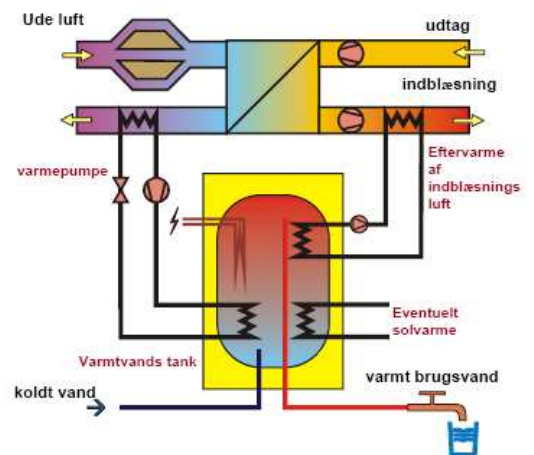

Figure 6. System layout, [Cenergia 2006].

Langenkamp one family house, Ebeltoft, Denmark



Figur 7. Photo of the house (left), Photo: Olav Langenkamp. System layout, (right).

The passive house Langenkamp is a one-family dwelling with a gross floor area of 170 m². The house has 7.8 m² of flat-plate collectors from Wagner. The storage tank has a volume of 500 litres. The solar system was dimensioned for a solar fraction of 65 % of hot water usage. The system is configured as the above except that heat is taken from coils in the ground instead of from the ventilation air.

The IEA5 Solar House in Pietesaari, Finland



Figure 8. The IEA5 solar house. Photo: VTT.

The IEA5 solar house is a demonstration of the IEA International Energy Agency's Task 13 Solar Low-Energy Houses. The house has 10 m² solar collectors located on the roof. It also has a 2.1 kW PV-system, which takes up most of the south facing roof area. The thermal storage consists of a 3 m high tank. The technical room locates in the middle of the house, and part of the system losses can be utilized as internal load. The design aimed at stratification in the tank to allow maximum utilization of solar energy. Solar energy supply is located at the bottom of the tank. The design aim was to cover at least 50% of the DHW demand and all space heating demand from April to September.

The house was monitored over a period of 3 years. The solar system supplied 19 kWh/floor-m² of heating energy, of which 12 kWh/m² was supplied for hot water heating, and 5 kWh/m² for space heating as storage losses. System losses were approximately 2 kWh/m², however, the measurements did not give the exact energy performance data for each use. The energy demand of 34 kWh/m² for hot water was higher than expected, but the solar heat supply was as expected. The storage losses caused overheating in the summer, however, the indoor temperature never exceeded 25 °C. Cooling for the house was provided by boosting the ventilation. The primary heat source for the house is ground heat. The heat pump runs typically from October to March, and thus the solar thermal system covered the thermal energy demand during the summer period.

The performance of the building was simulated using TASE simulation program. The program was not well suited for this kind of system simulation. The tank design was based on anticipated energy demand of space heating in spring and early autumn covered with low temperature floor heat distribution. The results of a three year monitoring period showed that the tank size and height were overestimated. Another lesson learned was that the solar heating system was too complicated. A house with low heating demand should be equipped with a simple system, as combining different heat sources do not serve for better energy-efficiency.

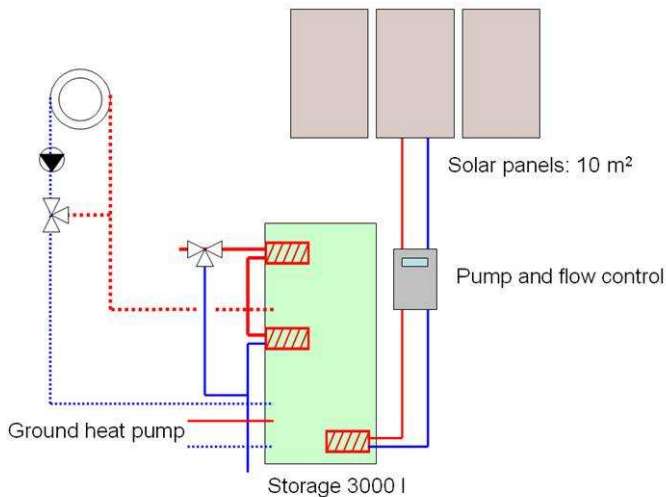

Figure 9. System layout (left) and photo into the technical room (right). Photo and illustration: VTT.

Løvåshagen, Bergen, Norway

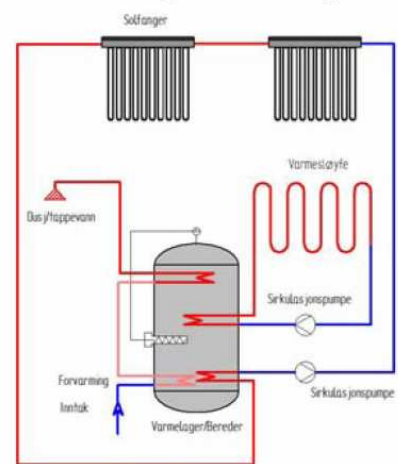

Figure 10. Left: The Løvåshagen passive houses with south facing solar collectors on the roof, illustration: ABO Architects. Right: System layout, Illustration: Skjøelberg.

The passive house project that is under construction at Løvåshagen encompasses 28 apartments of about 75 m² heated floor area. Each apartment has a separate solar heating system that is coupled to DHW tanks located in the bathrooms. The solar collectors are vacuum tubes with heat pipes from Apricus, each with an absorber area 3.2 m². The DHW tanks are 300 litres. The apartments also have a water heating system in the bathroom floors and a radiator in the living room; both these systems are coupled to the DHW tank. The pipes in the floor are insulated to avoid too high surface temperatures. The computer program PolySun was used in the design stage, and the solar system was estimated to cover 40% of the DHW load.

I-Box, Tromsø, Norway

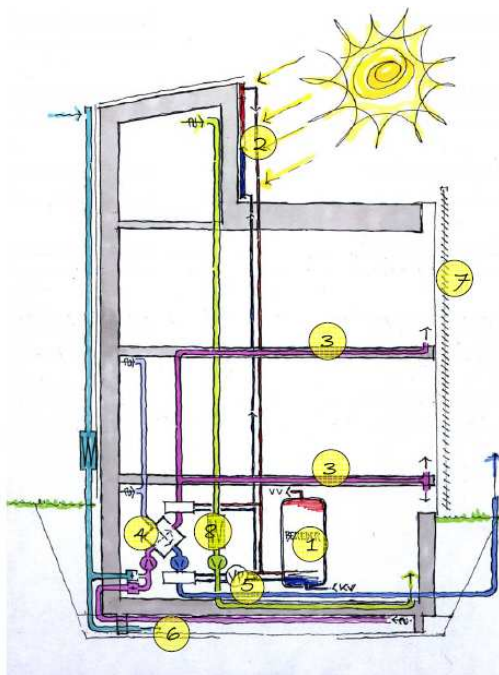

Figure 11. The I-box one-family house (left) and system layout (right) Photo and illustration: Steinsvik Architects.

Seven I-Box single family houses have been constructed at 2 locations in Tromsø during 2005-2007. The houses each has a Vitotres compact unit with extract air heat pump, ventilation air heat recovery and 5 m² Vitosol flat-plate collectors. A 250 litre DHW tank is integrated into the unit. The solar collectors are placed on the vertical south facing facade at the top of the building. The solar system is estimated to cover about 50% of the DHW demand.

NorOne, Sørumsand, Norway

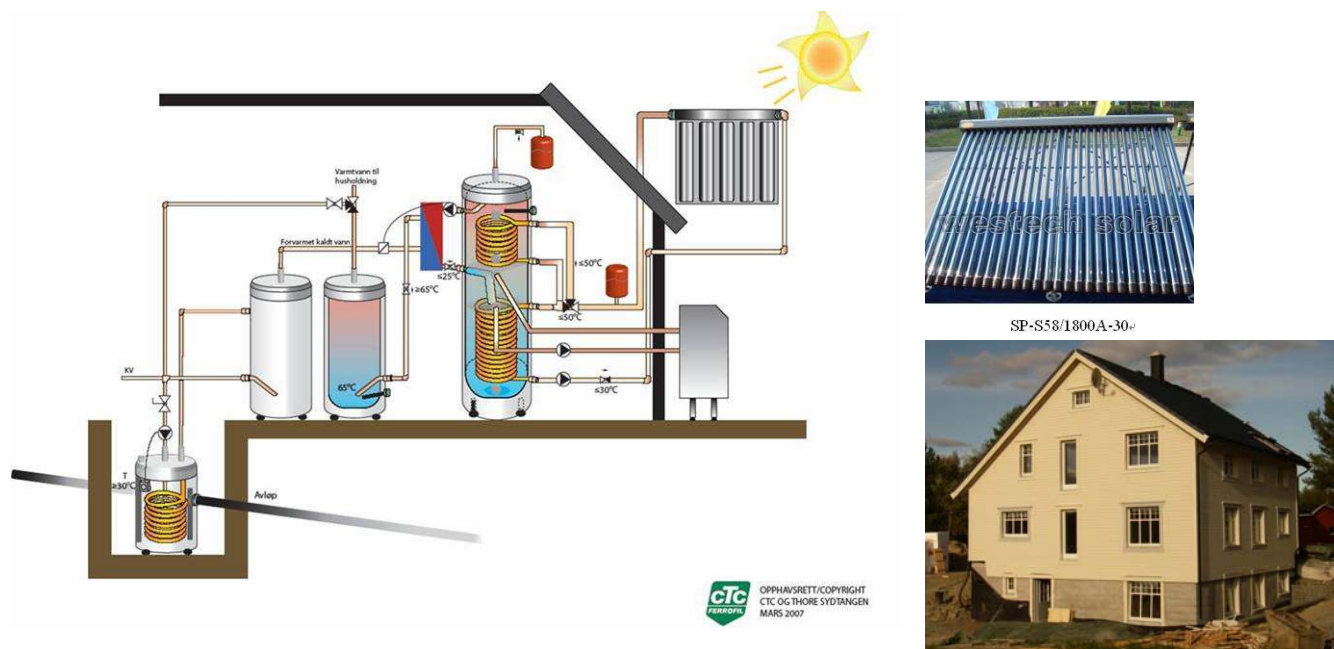

Figure 12. Left: System layout (illustration CTC Ferrofil). Upper right: Vacuum pipe collectors from Westech. Lower right: Photo of the SolarOne house (Photo: Harald Ringstad).

The NorOne house is a 345 m² single family dwelling that was constructed during fall 2007. The house has vacuum tube collectors from Westech with 2.4 m² absorber area and 5 m² gross collector area. The solar system is coupled to a 500 litre storage tank which is also coupled to an air-source heat pump for auxiliary heating. In addition, the store may be fed by preheated water from a separate grey-water waste heat recovery system.

Summary

All of the systems are designed to meet 40-60% of the DHW needs on a yearly basis, which means that they will supply nearly 100% of the DHW need during the summer. Computer simulation programs were used to estimate the performance of all systems. Three of the system has been monitored, and the results showed that in two of the cases the actual solar fractions achieved were about 30% lower than the design values. Collector absorber areas range from 2.5-10 m² per dwelling unit, the systems with vacuum type collectors have the smallest areas. Most of the systems are around 4 m² absorber area per dwelling unit. Storage volumes range from 150 – 1000 litres per dwelling unit, or from 60-200 liters/m² absorber area, with most of the systems around 75 litres per m² absorber area. Auxiliary heating is most often provided by electricity, several of the systems have heat pumps, and one system is coupled to the district heating system.

References

- [Boström et al 2003] Boström et al, "Tvärvetenskaplig analys av lågenergihusen i Lindås Park, Göteborg ", Arbetsnotat Nr 25 , Statens Provningsanstalt, Februari 2003, ISSN 1403-8307
- [Cenergia 2006] Cenergia Energy Consultants, "CO₂ neutralt lavenergibyggeri med solceller", Energistyrelsen (oktober 2006).
- [Hestnes et al 1997] Hestnes, A. G, A. Hastings and B. Saxhof (eds), "Solar Energy Houses. Strategies, Technologies, Examples." James & James (1997).
- [Janson 2008] Janson, U., "Passive houses in Sweden. Experiences from design and construction phase", Licenciate Thesis, Lund University, Lund Institute of Technology, Department of Architecture and Built Environment, Division of Energy and Building Design, ISBN 978-91-85147-24-3.
- [LTH 2007] http://www.ebd.lth.se/forskning/passivhus_demonstrationsprojekt/
- [Pedersen 2006] Pedersen, P. V. "Bygningers energibehov skal halveres inden år 2030". IDA-BYG 7. (september 2006), http://ida.dk/NR/rdonlyres/92CED2C7-70C4-47DC-941C-620525DAF5C4/0/Peder_Vejsig.pdf.
- [Wall 2008] Wall, M., "Passivhus i Sverige - erfaringer fra byggede eksempler", Forelesning på EVU-kurset Lavenergiboliger og passivhus, Norges teknisk-naturvitenskapelige universitet, Trondheim, 31. januar 2008.