



Aalborg Universitet

AALBORG UNIVERSITY
DENMARK

Utilizing Network QoS for Dependability of Adaptive Smart Grid Control

Madsen, Jacob Theilgaard; Kristensen, Thomas le Fevre; Olsen, Rasmus Løvenstein; Schwefel, Hans-Peter; Totu, Luminita Cristiana

Published in:
Energy Conference (ENERGYCON), 2014 IEEE International

DOI (link to publication from Publisher):
[10.1109/energycon.2014.6850526](https://doi.org/10.1109/energycon.2014.6850526)

Publication date:
2014

[Link to publication from Aalborg University](#)

Citation for published version (APA):
Madsen, J. T., Kristensen, T. L. F., Olsen, R. L., Schwefel, H-P., & Totu, L. C. (2014). Utilizing Network QoS for Dependability of Adaptive Smart Grid Control. In *Energy Conference (ENERGYCON), 2014 IEEE International* (pp. 859-866). IEEE Press. <https://doi.org/10.1109/energycon.2014.6850526>

General rights

Copyright and moral rights for the publications made accessible in the public portal are retained by the authors and/or other copyright owners and it is a condition of accessing publications that users recognise and abide by the legal requirements associated with these rights.

- Users may download and print one copy of any publication from the public portal for the purpose of private study or research.
- You may not further distribute the material or use it for any profit-making activity or commercial gain
- You may freely distribute the URL identifying the publication in the public portal -

Take down policy

If you believe that this document breaches copyright please contact us at vbn@aub.aau.dk providing details, and we will remove access to the work immediately and investigate your claim.

Utilizing Network QoS for Dependability of Adaptive Smart Grid Control

Jacob Theilgaard Madsen ^{#1}, Thomas le Fevre Kristensen ^{#2}, Rasmus L. Olsen ^{#3},
Hans-Peter Schwefel ^{##4,5}, Luminita C. Totu ^{#6}

[#] *Department of Electronic Systems, Aalborg University*

Fredrik Bajers vej 7, Denmark

{¹jam, ²tfk, ³rlo, ⁴hps, ⁶lct}@es.aau.dk

^{*} *Forschungszentrum Telekommunikation Wien - FTW*

Donau-City Str 1 1220 Wien, Austria

⁵schwefel@ftw.at

Abstract—A smart grid is a complex system consisting of a wide range of electric grid components, entities controlling power distribution, generation and consumption, and a communication network supporting data exchange. This paper focuses on the influence of imperfect network conditions on smart grid controllers, and how this can be counteracted by utilizing Quality of Service (QoS) information from the communication network. Such an interface between grid controller and network QoS is particularly relevant for smart grid scenarios that use third party communication network infrastructure, where modification of networking and lower layer protocols are impossible. This paper defines a middleware solution for adaptation of smart grid control, which uses network QoS information and interacts with the smart grid controller to increase dependability. In order to verify the methodology, an example scenario of a low voltage grid controller is simulated under imperfect network conditions.

Index Terms—Smart Grid, Co-simulation, PLC, QoS, Adaptive Control, Network Aware Control.

I. INTRODUCTION

Energy production in today's power grid is mainly done using non-renewable energy sources [1], it is, however, desired to rely more and more on several types of renewable energy sources in the future. Private wind turbines and solar panels are gaining popularity at low voltage levels, meaning that energy production is changing from a more centralized system, to a highly distributed system, as well as part of the energy production moving from the high voltage(HV) and medium voltage(MV) layers to the low voltage(LV) layer. To enable the power grid to handle future requirements of a highly dynamic energy production and consumption at this level, it must be possible for the distribution grid to have better control of grid assets.

To facilitate this added control intelligence in smart grid systems, a communication infrastructure must be in place as well as functionality to allow grid asset control, which for the LV grid is not yet implemented. Since the assets are highly distributed, dependable communication is required to allow proper grid operation, however, this is not without challenges since several trade-off's have to be made, [2].

Because dependable communication infrastructures tend to be expensive, either a suitable compromise between depend-

ability and price must be found or the dependability of economically feasible communication infrastructures must be increased. Therefore, low complexity solutions to control grid assets over existing (or low cost deployment communication networks), but imperfect communication networks are required. This paper illustrates the example of asset control in distribution grids with poor communication network performance.

The control scenario in this paper is based on a smart grid communication scenario that uses an open and heterogeneous communication infrastructure [3]. This open communication infrastructure may be a third party public communication network, where the IP stack must be used, and access to lower communication network layers is restricted. The solution proposed in this paper will, therefore, only contain communication network adaptations on layers above the transport layer. A consequence of the use of a public heterogeneous communication network is that QoS will change dynamically over time. This paper presents a solution which adapts a smart grid controller to counteract poor communication network performance, and gain improved controller performance. The conceptual approach of adapting control to network QoS is illustrated in Figure 1; the figure shows the control loop of grid assets in the outer circle. The required communication infrastructure is monitored and information on the network performance is used to adapt the control approach via middleware functionality. The latter corresponds to the upward red arrow in the figure; the downward direction, adjusting network QoS to control demands, is treated in [3] but beyond the scope of this paper.

The proposed solution will be implemented for a given LV grid controller controlling a population of refrigerators. The adapted controller will then be simulated to illustrate the effectiveness of the adaptation method.

The rest of the paper is structured as follows; first an overview of the existing state-of-the-art is provided. Then, in section III, an overview of the system architecture and generalized protocol stack is given. Section IV describes the example control solution as well as the proposal for extension,

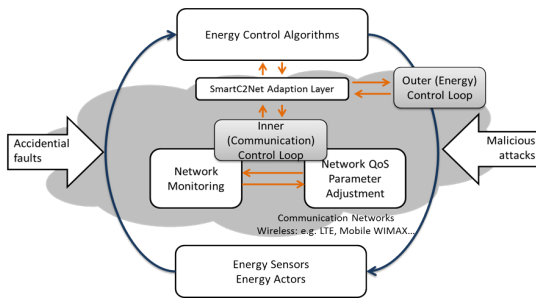

Fig. 1: Conceptual dual loop for dependable smart grid operation, [3].

which realizes the adaptation of the control system to the communication network properties. Section VI describes the simulation approach and the evaluation results from the simulation experiments, demonstrating the benefits of the proposed adaptation scheme.

II. STATE OF THE ART

Reference [4] gives an overview of the different technologies available for smart grid communication, and lists the relevant standards. In Ref. [5] the viability of using power line communication (PLC) is investigated through simulation. Two different topologies for the smart grid communication are proposed and then simulated. This paper sets certain requirements that the communication should adhere to, and investigates if it is possible to meet these requirements using PLC. The results show that PLC can fulfill the stated requirements in only a limited set of scenarios, and hence more relaxed communication requirements need to be deployed, or a different communication solution must be used. The poor performance of PLC is also shown in Ref. [6], where it is shown that under certain conditions, bit error rates in the order of 10^{-2} can be expected.

Adapting a control algorithm to the communication network QoS has been discussed in different papers, but it is scenario dependent which adaptation scheme is the most suited for the task. Adaptation should preferably be done without an extensive restructuring of the control algorithm. According to Ref. [7], it is possible to adapt the control algorithm without major changes. The idea is to modify the control loop time while leaving the parameters of the control algorithm unchanged. While this algorithm is not optimal, it can improve the overall performance if the increased control loop time leads to lower communication network traffic, thus ensuring all data in the communication network reaches its destinations before the next sample time. Furthermore, Ref. [7] shows that a control algorithm with variable control loop time will still be stable under certain conditions. A different method for adapting the control algorithm to the communication network state is presented in Ref. [8]. The distributed control algorithm is changed dynamically depending on the QoS of the communication network as estimated by the distributed controllers. This approach changes the control loop time, which either leads suboptimal control, or recalibration of

control parameters. Ref. [9] proposes to adapt the network to the controller by choosing the optimal throughput to allocate to based on different power cost functions.

III. SYSTEM ARCHITECTURE AND USE CASE

In this section we introduce the system architecture and the example case on which we focus our work. Furthermore, we describe the embedding in the communication stack that allow the transparent adaptation of the controller to changing communication network properties.

A. System architecture and assumptions

The adaptation approach in this paper focuses on the low-voltage grid controller, whose embedding in a hierarchical overall smart grid control architecture is shown in Figure 2 [10]. From higher level, the LV grid controller receives set points used as a reference for optimal power consumption. Due to the restricted number of assets in the LV grid, this consumption may not always be achievable, and so, power may flow in and out via the transformer station as needed, but following at best effort the level of a reference signal from the medium voltage (MV) grid controller. However, the in- and out-flux of power between the grid domains should be kept at a minimum for a reliable operation (the more predictable a LV grid domain is to the MV controller, the less effort it is to maintain this, and chances for energy waste is reduced). Toward the MV grid controller, the LV controller thus offers a flexibility service in terms of following set points given by the MV controller. In this paper we focus on the LV grid controller and assume that the set points from the MV grid controller are given.

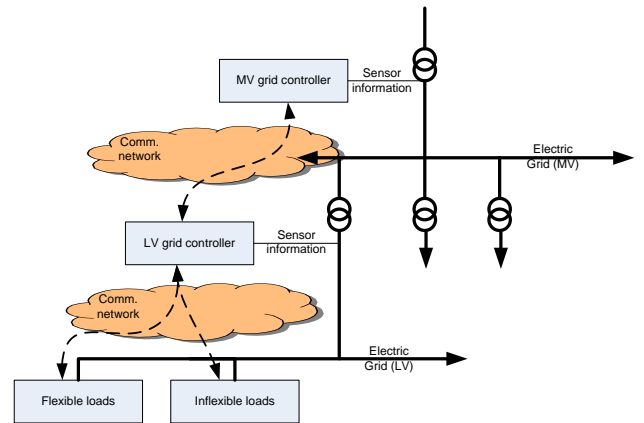

Fig. 2: Hierarchical Smart Grid control architecture [10].

To achieve the goal of balancing production and consumption, the LV grid controller is envisioned to be able to interact with the assets connected to the LV grid. We distinguish between two different types of assets:

- Flexible loads: These assets may be controlled fully by the LV grid controller.
- Inflexible loads: These assets cannot be controlled, but rather show a stochastic behaviour.

We refer to Ref. [11] for more information on these types of assets. As shown, the LV grid controller needs to interact via a communication network with the assets. In the next section we propose some addition to the communication network protocol stack to improve the controller performance under imperfect network conditions.

B. Adaptive communication network functionality

We describe a middleware solution that performs adaptation of the control signal and is performed based on the QoS of the used communication network (Downstream Adaptation). Using this middleware, the controller can focus on the originally targeted control operation while the adaptation to changing network performance is taken care of by the middleware. Further, we also propose similar middleware adaptation for access to measured sensor data (Upstream Adaptation). To be able to perform this adaptation based on communication QoS, packet loss estimates must be provided by the network monitoring functions. These QoS estimations can be used to adapt the control signals. The proposed middleware will be placed on the controller side of the communication network for both downstream and upstream adaptation. An overview of the solution and how it interacts with a control system can be seen in Figure 3.

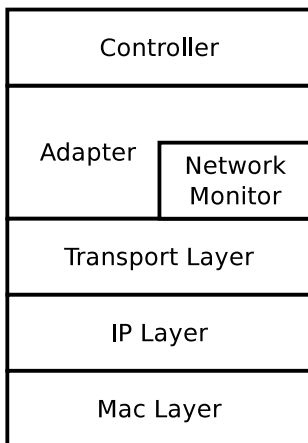

Fig. 3: Illustration showing how the proposed solution is placed in the communication network stack.

Figure 3 also illustrates where the adapter and the communication network monitor is placed in the communication network stack. As seen on the figure, the communication network monitor is placed partly between the transport layer and the adaptation layer. This allows the communication network monitoring to be done using passive network monitoring.

IV. EXAMPLE SMART GRID CONTROL SCENARIO

In this section we describe an example LV grid controller scenario that will be controlling the assets as previously described. The scenario considers the control of power consumption of thermostatic loads in a LV grid scenario.

A. Regulation of thermostatic loads

A block diagram of the control scenario is shown in Fig. 4, for which the core design without the communication network, has previously been published in [12]. This structure contains three main elements:

- A number N of refrigerator units F_i each equipped with a modified thermostat controller K_i , $i \in \{1 \dots N\}$, and each with the power consumption y_i .
- The cumulated inflexible power consumption w that acts as a predictable disturbance.
- The main controller consisting of the supervisor control, estimation and dispatch blocks.

The objective of the controller in this scenario is to reduce the peaks in the overall power consumption by effectively utilizing the characteristics and restrictions of the grid assets and coordinating the power intake of the asset groups. For the case study we look at thermal energy storage in terms of refrigerators. These refrigerators will by the objective of the control thus be timely coordinated to increase power consumption, and thereby store "coldness", before power peaks caused by the inflexible loads and then coordinated to safely turn off during that peak, and thereby use the previously stored "coldness". For refrigerators, the challenges are that these are restricted in terms of operating temperatures, which from time to time disallow operation of them as desired.

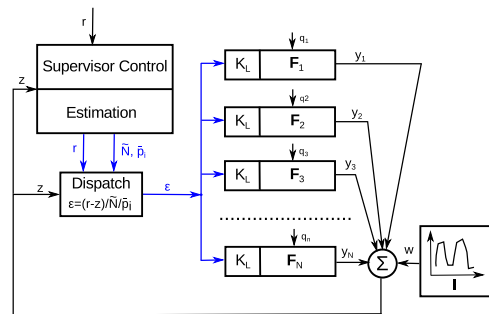

Fig. 4: Control of thermostatic loads [12].

The operation of the control algorithm can be sketched as follows:

```

for each minute do
  Estimate Refrigerators States,  $\tilde{N}^{off}, \tilde{N}^{on}$ ;
  Obtain Power Consumptions,  $z, \bar{p}$ ;
  Compare to reference signal,  $r$ ;
  Calculate Control signal,  $\epsilon$ ;
  Dispatch signal to refrigerators;
  for Each Refrigerator do
    | React to received signal,  $\epsilon$ ;
  end
end

```

\tilde{N}^{on} , and \tilde{N}^{off} are the estimated number of refrigerators that are in the *on* or *off* state. z and \bar{p} is the measured power consumption of the LV grid, and the average power consumption of a refrigerator respectively. \bar{p} is assumed known by the controller, but in practicality would be provided by each refrigerator when registering, and then averaged.

The LV grid controller then coordinates with the MV grid controller, and calculates a power consumption reference r for a given time horizon, e.g. a day. In this paper we delimit ourselves from deriving the reference signal r , and the used

reference is therefore generated artificially based on the used behaviour of the inflexible loads in the considered LV grid. The exact behaviour of the reference signal is not in focus in this paper, as we want to analyze the concept of adaptations based on imperfect communication networks and not include MV grid control behaviour.

$$\tilde{\epsilon}_k = \begin{cases} \frac{(r_k - z_k)}{\tilde{N}_k^{off} \cdot \bar{p}}, & \text{for } r_k > z_k \\ \frac{(r_k - z_k)}{\tilde{N}_k^{on} \cdot \bar{p}}, & \text{for } r_k < z_k \end{cases} \quad (1)$$

$$\epsilon_k = \begin{cases} \tilde{\epsilon}_k, & \text{for } -1 \leq \tilde{\epsilon}_k \leq 1 \\ \text{sign}(\tilde{\epsilon}_k), & \text{otherwise} \end{cases} \quad (2)$$

The control signal, ϵ , is calculated according to Equation (1) and (2) and sent to the refrigerators. The control signal indicates the fraction of refrigerators in the right state that should change their state; if $\epsilon < 0$ then a fraction of ϵ refrigerators should switch to the *ON* state, if $\epsilon > 0$ in the reverse direction. For example, an ϵ value of 0.2 indicates a request of the supervisor center for 20% of the refrigerators currently in the *off* state to switch to the *on* state, which as being executed gives an overall increase in power consumption, but at the same time adds to the thermal energy storage in the form of "coldness". Similarly, an ϵ value of -0.2 indicates a request of the the supervisor center for 20% of the refrigerators currently in the *on* state to switch to the *off* state, which translates into an overall power consumption decrease, and a loss of "coldness".

The change of state at the i 'th refrigerator leads to a power consumption, y_i , in which the total consumption of the refrigerators, z , are simply the sum of all these. Since there are many other loads on the electrical grid, noises and disturbances, w (from inflexible loads in this specific scenario), is added to the measured load signal. The controller would need to estimate the controllable load of the refrigerators y , and thus the average power consumption of a single refrigerator, \bar{p} , is multiplied by the estimate of how many refrigerators are *on* or how many are *off*. All this happens at discrete points in time, notated by the index k for the k 'th step of the control.

In order to ensure that refrigerator temperature (and other potential constraints) are not broken at the individual unit, the actual power consumption decision is taken by the local refrigerator controller K_i . Every refrigerator in the group receives the same message, in case of perfect communication, and the dispatch is carried out by a local randomization in the following way. If the refrigerator unit is capable, given its local conditions, to safely turn *on* or *off* respectively, it will do so with a $|\epsilon|$ probability.

In this way, a simple control signal is dispatched to the assets which also respects local constraints of the assets.

1) *Assumptions of the control for thermostatic loads:* The control approach in [12] is based on several assumptions and we briefly review these here. First, the refrigerators have similar, although not identical parameters, and the average parameter values are known by the controller. This resembles

a situation where the LV controller has been preconfigured, e.g. via registration of grid assets, such that a set of flexiable assets are able to be controlled.

Secondly, the group of refrigerators together with the inflexible consumption are within the same electrical LV grid domain, making it possible to measure the cumulated power consumption z , for example as illustrated in Figure 2 at a MV/LV transformer station. Furthermore, it is assumed that the states \tilde{N}_k^{off} and \tilde{N}_k^{on} can be estimated accurately by the controller.

The communication in [12] is considered to be done over an ideal link, i.e. the assumption is that all refrigerators receive the control signal and in due time for the control operation.

2) *Modifications of the controller:* In order to fit the controller to the scenario, it has been modified in certain areas.

- The first one regards a change of the ϵ calculation. In the original controller described in [12], the control signal ϵ is modified such that the controller performs a more aggressive control when the power consumed is above the reference. This aggression has been removed such that the controller attempts to reach the reference exactly, instead of trying to be just below it. The reference signal r has been lowered accordingly.
- \tilde{N}^{off} and \tilde{N}^{on} are estimated via feedback from the refrigerators to the controller. After receiving the control command, all refrigerators reply with their (potentially updated) binary state. This feedback was not included in the original controller in Ref [12].

Since the controller has been modified, and a new performance metric is used, the controller can no longer be considered optimal as defined in [12]. This means that control adaptations can cause increased control performance by pure luck. For this reason the controller is recalibrated by changing the ϵ calculations to:

$$\epsilon_k = \begin{cases} \frac{(r_k - z_k)}{\tilde{N}_k^{off} \cdot \bar{p}} \cdot C, & \text{for } r_k > z_k \\ \frac{(r_k - z_k)}{\tilde{N}_k^{on} \cdot \bar{p}} \cdot C, & \text{for } r_k < z_k. \end{cases} \quad (3)$$

Where C is a constant. The value of C is found by simulating the controller under perfect network conditions using different values for C , and thereby determining its optimal value. This simple recalibration is done as controller design is out of scope of this paper, however, in a practical implementation, a recalculation of control parameters should be done instead.

B. Communication network

In this scenario we use narrowband PLC for communication between the LV grid controller and each refrigerator. Because we have 60 seconds to dispatch the control signal ϵ , communication delays in the ranges of few seconds only have minor impact. However, packet losses are a focus which impact differently for UDP and TCP based protocols, especially for high packet loss communication technologies like PLC.

The parameters of the network scenario that is used in Section VI for evaluation are listed in Table I. We assume a broadcast network with a star topology, for which we can

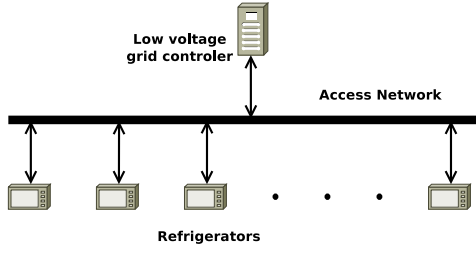

Fig. 5: Overview of the considered communication network.

broadcast or multicast the ϵ value directly to the assets, and each asset unicast their state back to the controller.

Parameter	Value
PLC Packet loss	70[%]
PLC throughput	3000[$\frac{b}{s}$]
Refrigerators	100
Control interval	60 [s]
Simulation Time	15 [days]
Correction Factor	1,2
Avg. refrigerator power consumption	100 [W]
Refrigerator temperature range	2-5 [$^{\circ}$ C]
Min. refrigerator on/off time	5 [min]

TABLE I: Parameters used for the simulations.

A high packet loss probability of 70% was chosen to illustrate the impact of imperfect network conditions on the controller. The controller was simulated with different values of packet loss, but proved highly resistant to packet losses due to the fact that it was designed with stochastic deviations in mind. As delays does not have a significant impact on the controller in this scenario, the value for the throughput was chosen sufficiently high to support the scenario. Ref. [6] showed that PLC can have BERs as high as 10^{-2} , which for the packet sizes in our scenario translate into 92% packet loss probability. In practice, the impact of bit errors can be reduced by deploying error correcting codes.

C. QoS-based Adaptive Control

The performance decrease is mainly caused by dropped packets on the communication network. One method to counteract this is to use a reliable transport protocol such as TCP. This does, however, come at the cost of increased delay and overhead, especially compared to UDP, since the control algorithm allows for the use of multi casting. Furthermore TCP becomes very slow in scenarios with high packet loss rates due to its congestion control, or it may even drop connections entirely and then has to perform connection re-establishment. If the overall packet-loss probability can be measured or estimated, the hypothesis is that the control signal can be modified to take into account the loss of recipients by counter adjusting the control signal to the amount of refrigerators expected to receive the signal. The fraction of refrigerators that should change their state then needs to take into account the predicted message loss to achieve the level of control expected by the controller.

In the considered control system, the control parameter ϵ is a measure of the amount of refrigerators which should change state and is calculated based on the amount of available refrigerators in the system, N . The effective number of reached devices will be smaller than N , as some refrigerators will not receive the control signal. These become an inflexible unit in practice. To counteract the effect of the packet loss, a new control parameter ϵ' is defined, as shown in eq.(4). This is calculated from the reduced value of number of nodes that receive the downstream adaptation request, $N \cdot (1 - P_l)$

$$\epsilon \cdot N = \epsilon' \cdot N \cdot (1 - P_l) \Rightarrow \epsilon' = \frac{\epsilon}{1 - P_l}. \quad (4)$$

In this way, ϵ is being scaled according to the expected loss of recipients, however, requiring that the packet loss is known.

When a refrigerator receives a control signal from the supervisor center, it will respond with its state information. In scenarios of packet loss, the correct reception of this response message at the controller requires that both the broadcast message and the response message are successfully transmitted. Assuming independent packet loss with probability p_l in both directions, an estimator of packet loss is obtained from the the number of received response messages as follows:

$$\frac{\hat{N}_{received}}{N} = (1 - P_l)(1 - P_l) \Rightarrow P_l = 1 - \sqrt{\frac{\hat{N}_{received}}{N}}. \quad (5)$$

The controller uses the amount of refrigerators in a certain state when calculating epsilon, however the measured number of refrigerators in this state and the actual number might not be the same due to packet loss. Thus the \tilde{N}_k^{on} or \tilde{N}_k^{off} should be modified to account for packet loss. This leads to a new calculation of ϵ , being:

$$\epsilon_k = \begin{cases} \frac{(r_k - z_k)}{\tilde{N}_k^{off} \cdot \frac{N}{\tilde{N}_{received}} \cdot \bar{p}}, & \text{for } r_k > z_k \\ \frac{(r_k - z_k)}{\tilde{N}_k^{on} \cdot \frac{N}{\tilde{N}_{received}} \cdot \bar{p}}, & \text{for } r_k < z_k. \end{cases} \quad (6)$$

This means that there are two kinds of adaptation of the controller, one which scales ϵ with the estimated packet loss, and one which corrects the counted amount of *on* or *off* state refrigerators based on estimation of missing responses. Later we refer to these two types of adaptations to a) upstream adaptation and b) downstream adaptation, representing the direction of information flow, respectively. Using both adaptations the ϵ formula becomes:

$$\epsilon'_k = \begin{cases} \frac{(r_k - z_k)}{\tilde{N}_k^{off} \cdot \frac{N}{\tilde{N}_{received}} \cdot \bar{p}} \cdot \frac{1}{1 - P_l}, & \text{for } r_k > z_k \\ \frac{(r_k - z_k)}{\tilde{N}_k^{on} \cdot \frac{N}{\tilde{N}_{received}} \cdot \bar{p}} \cdot \frac{1}{1 - P_l}, & \text{for } r_k < z_k. \end{cases} \quad (7)$$

V. SIMULATION METHODOLOGY

In order to evaluate the adaptation approach described in section III-B an example scenario has been implemented in a simulation framework. A framework for combined simulation of the control method and of the network behavior is developed for that purpose. We used MATLAB and OMNeT++ in our

work, but conceptually, the procedure would be similar using other tools, it would probably require extensive changes to the framework. MATLAB is used to simulate the LV grid controller, and will therefore be considered the control simulator for the purpose of this paper.

Since the two tools, MATLAB and OMNeT++, are working with different time concepts, we need to ensure that the two tools interoperate properly in order to produce useful results. Coupling the operation between MATLAB and OMNeT++ is nothing new, as for example illustrated in Ref. [13] where it is used to model indoor wireless networks, and for that reason we will not go into detail regarding this coupling. Figure 6 shows the workflow of the two simulators for a single control loop.

OMNeT++ is handling the time of the simulation, and sends messages to MATLAB at the points where system dynamics and control actions need to be processed. To simulate the transport over the communication network, OMNeT++ requires information from MATLAB regarding the amount of data to send, but it does not require actual packet content, this content must therefore be handled internally in MATLAB. Once a packet reaches the destination in the OMNeT++ simulation, the simulation time is paused and MATLAB is given information on the specific receiver entity of the packet. The execution flow now moves into MATLAB, which performs the required processing and returns control to OMNeT++ when done. The simulation time in OMNeT++ is then updated with an added processing delay. The control program can be triggered from OMNeT++ by communication network events such as the arrival of a packet, or by clock events, as is the case of the main control loop.

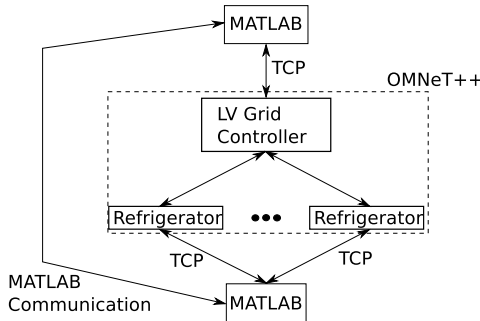

Fig. 7: Interfaces between OMNeT++ and MATLAB.

It was chosen to have OMNeT++ initiate and handle the communication with MATLAB, and not the other way around, because it also handles simulation time. This means that OMNeT++ must know the time it takes for each control part to be processed. This process is illustrated in Fig. 6. The structure of the communication between MATLAB and OMNeT++ is shown on Figure 7.

VI. EVALUATION OF THE NETWORK AWARE CONTROL SYSTEM

In this section we provide an overview of the results we obtained and discuss them in relation to the framework we

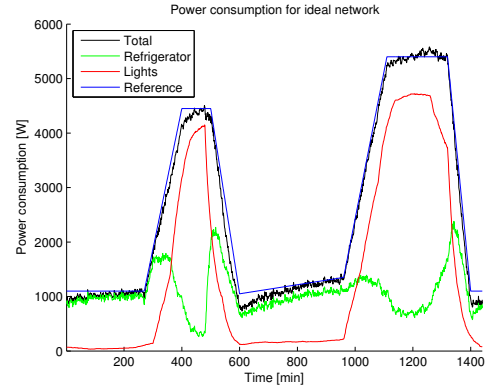

Fig. 8: Base case simulation of the controller under ideal network conditions.

setup.

A. Performance metric definition

The key performance metric of the control algorithm is defined as the error between the total consumed power and the power reference. This error to some degree reflects the effort, that the MV grid controller has to do in terms of extra effort of providing or distributing excess power over time. The parameter is calculated as

$$Err_p(k) = |r_k - z_k| \quad (8)$$

Summing up over time, and averaging, gives an indication of the energy demand for the particular LV grid domain over a time period.

$$Err_e(K) = \frac{1}{K} \sum_{k=0}^K |r_k - z_k| \quad (9)$$

B. Base scenario

In the base case scenario, we make a simulation run of the control simulation without any influence of the communication network.

Figure 8 illustrates clearly the role of the controller, namely to store energy in the refrigerators as before a power peak arises. It is seen by the initial rise of power consumption by the refrigerators, which during the peak load period is reduced. After the peak load period the refrigerator power consumption increases significantly to recover from the energy drain in the thermal energy 'bank'. The cycle repeats itself for the late afternoon peak, however, not without violating the setpoint for which the controller was supposed to keep. This is a result of the stochastic elements. Any deviation from the reference relates to cases where power must be either taken from or input to the LV grid with the interaction of the MV grid controller.

Investigating the control scenario with lossy and delayed communication is now used to analyze 1) the impact of imperfect communication networks on top of the control system, and 2) how well this can be remedied by our proposed solution of manipulating the control and feedback signaling

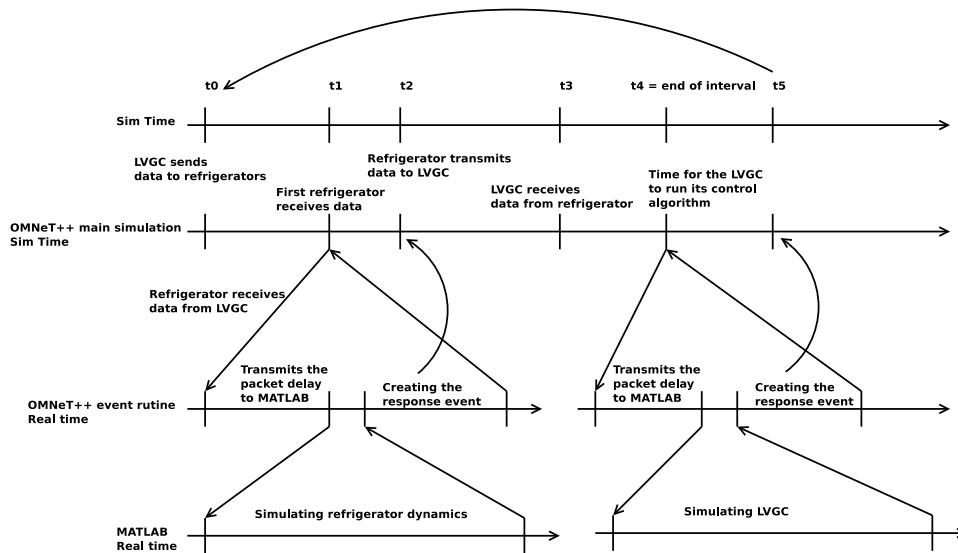

Fig. 6: Message sequence diagram of an low voltage grid controller (LVGC) communicating with a single refrigerator.

without the knowledge of the controller to make up for packet losses.

C. Evaluation of the communication network influence and proposed solution

Five different simulations have been done, one with perfect communication network conditions, which will serve as the best achievable performance (lowest error), and the four combinations of with and without upstream and downstream adaptation. Where the one without any adaptation will show how the controller performs under imperfect communication network conditions, and the rest will show the effect of the adaptations. 15 days have been simulated for each simulation and the error is calculated for each minute. The average error was then calculated for each minute of the day. Due to significant fluctuations in this plot it was difficult to see any differences between the schemes. To show the trends in the error it was chosen to make a moving average of the error with a window size of 50 minutes, which can be seen in Figure 9.

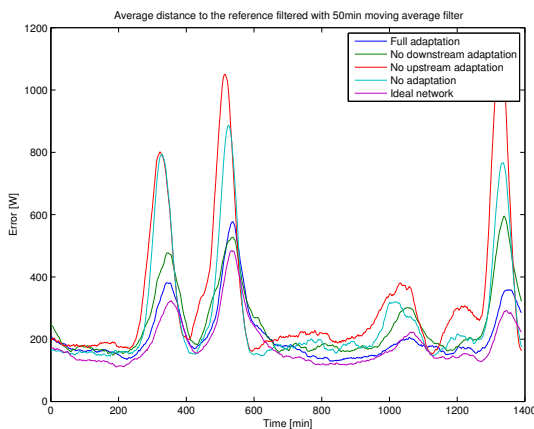

Fig. 9: Moving average of the error with a window size of 50 minutes.

The results in Figure 9 shows first a substantial impact due to the communication network imperfections (teal curve) and secondly that the proposed adaptations (blue curve) are effective. The error in terms of energy losses, becomes worse with the communication network degradation and if nothing is done, this may have impact on the overall strategy of which the MV controller needs to take if multiple LV grids should be considered within one MV control domain.

The average error over an entire day has been calculated for each scheme, by taking the average error for each day, and afterwards averaging this over the 15 simulated days. The standard deviations of the error have been calculated likewise.

Adaptation	Mean error	95 % Confidence interval
Ideal network	184,01	171,88 - 196,14
No adaptation	263,28	249,19 - 277,36
No upstream adaptation	324,19	314,91 - 334,12
No downstream adaptation	249,75	234,91 - 264,59
Full adaptation	211,42	200,91 - 221,92

TABLE II: Performance of the different schemes.

It is seen in Table II, that the imperfect communication network conditions have impact on the controller performance. It is also seen that only adapting for downstream imperfections will cause the controller to be over aggressive, and an increased error is experienced. It can also be seen that only adapting for downstream imperfections reduces the performance significantly. If we consider the calculation of ϵ as shown in equation (7), we see that if there is no modification of the received responses (no upstream adaptation), ϵ will increase, making the controller more aggressive. Furthermore if ϵ is adapted based on the packet loss it becomes even larger, thus even more aggressive. This leads to the controller becoming overly aggressive leading to poor performance. The performance can be increased significantly by adapting for upstream imperfections, and even more by adapting for both upstream and downstream imperfections, leading to a total

improvement of around 20 %.

VII. CONCLUSION AND FUTURE WORK

We introduce an approach to take measured communication network performance into account via parameter adaptation in middleware functions and show the effectiveness in simulation experiments. We also show that including communication network considerations when designing systems, like smart grids, where faults can be very expensive, is important. We propose a solution for this inclusion, where control signals are adapted according to communication network QoS measurements, and evaluate this in a LV smart grid control scenario using simulations. This can in principle be realized via a middleware solution as sketched here; however the detailed design in order to allow the middleware to act transparently to the control algorithm is not given in this paper.

We show that by adapting the controller to current communication network QoS estimations, the controller performance can be increased significantly (as seen when using full adaptation). It can, however, also be concluded that adapting the controller to the communication network can in some cases decrease control performance, if the controller becomes over aggressive (as seen when only considering downstream adaptations).

This paper shows how packet loss probabilities can be effectively included to increase control performance, however, further explorations into the inclusion of other QoS parameters such as latency and throughput can prove useful.

ACKNOWLEDGMENT

The authors would like to thank Tatiana Kozlova Madson for help with the development of a suitable simulation platform and Kartheepan Balachandran for help with data processing and useful discussions. The research leading to these results has received funding from the European Community's Seventh Framework Programme (FP7/20072013) under grant agreement N^o318023 for the SmartC²Net Project and from the Danish Research Council for the project EDGE. Further information regarding SmartC²Net is available at www.SmartC2Net.eu.

The Telecommunications Research Center Vienna (FTW) is supported by the Austrian Government and by the City of Vienna within the competence center program COMET.

REFERENCES

- [1] E. styrelsen, "Energistatistik 2010," 2010, ISBN: 978-87-7844-908-5.
- [2] Y. Yan, Y. Qian, H. Sharif, and D. Tipper, "A survey on smart grid communication infrastructures: Motivations, requirements and challenges," *Communications Surveys Tutorials, IEEE*, vol. 15, no. 1, pp. 5–20, 2013.
- [3] F. T. Wien, A. Universitet, T. U. Dortmund, Resiltech, R. S. S. Energetico, V. Omnitel, and E. E. E. Sistemas, "Fp7 smart control of energy distribution grids over heterogeneous communication networks project," 2013, <http://smarc2net.eu/>.
- [4] V. Gungor, D. Sahin, T. Kocak, S. Ergut, C. Buccella, C. Cecati, and G. Hancke, "Smart grid technologies: Communication technologies and standards," *Industrial Informatics, IEEE Transactions on*, vol. 7, no. 4, pp. 529–539, 2011.
- [5] F. Aalamifar, H. Hassanein, and G. Takahara, "Viability of powerline communication for the smart grid," in *Communications (QBSC), 2012 26th Biennial Symposium on*, 2012, pp. 19–23.

- [6] M. Korke, N. Hosseinzadeh, and T. Moazzeni, "Performance evaluation of a narrowband power line communication for smart grid with noise reduction technique," *Consumer Electronics, IEEE Transactions on*, vol. 57, no. 4, pp. 1598–1606, 2011.
- [7] J. Colandairaj, G. Irwin, and W. G. Scanlon, "Wireless networked control systems with qos-based sampling," *Control Theory Applications, IET*, vol. 1, no. 1, pp. 430–438, 2007.
- [8] M. Pohjola, "Adaptive control speed based on network quality of service," in *Control and Automation, 2009. MED '09. 17th Mediterranean Conference on*, 2009, pp. 784–789.
- [9] D. Niyato, P. Wang, Z. Han, and E. Hossain, "Impact of packet loss on power demand estimation and power supply cost in smart grid," in *Wireless Communications and Networking Conference (WCNC), 2011 IEEE*, March 2011, pp. 2024–2029.
- [10] G. Dondossola(eds.) and R. Terruggia(eds.), "Smarte2net deliverable d1.1: Smartc2net use cases, preliminary architecture and business drivers," 2013, <http://smarc2net.eu/>.
- [11] M. Petersen, K. Edlund, L. Hansen, J. Bendtsen, and J. Stoustrup, "A taxonomy for modeling flexibility and a computationally efficient algorithm for dispatch in smart grids," in *American Control Conference (ACC), 2013*, June 2013, pp. 1150–1156.
- [12] L. Totu, J. Leth, and R. Wisniewski, "Control for large scale demand response of thermostatic loads," *American Control Conference*, June 2013.
- [13] Z. Zhang, Z. Lu, Q. Chen, X. Yan, and L.-R. Zheng, "Cosmo: Co-simulation with matlab and omnet++ for indoor wireless networks," in *Global Telecommunications Conference (GLOBECOM 2010), 2010 IEEE*, 2010, pp. 1–6.