



**AALBORG UNIVERSITY**  
DENMARK

**Aalborg Universitet**

## **Papers**

*Volume 8: 2008-2014*

Thoft-Christensen, Palle

*Publication date:*  
2014

*Document Version*  
Publisher's PDF, also known as Version of record

[Link to publication from Aalborg University](#)

*Citation for published version (APA):*  
Thoft-Christensen, P. (2014). *Papers: Volume 8: 2008-2014*. Department of Civil Engineering, Aalborg University.

### **General rights**

Copyright and moral rights for the publications made accessible in the public portal are retained by the authors and/or other copyright owners and it is a condition of accessing publications that users recognise and abide by the legal requirements associated with these rights.

- Users may download and print one copy of any publication from the public portal for the purpose of private study or research.
- You may not further distribute the material or use it for any profit-making activity or commercial gain
- You may freely distribute the URL identifying the publication in the public portal -

### **Take down policy**

If you believe that this document breaches copyright please contact us at [vbn@aub.aau.dk](mailto:vbn@aub.aau.dk) providing details, and we will remove access to the work immediately and investigate your claim.

## CHAPTER 139

# STRUCTURE OF BRIDGE MANAGEMENT SYSTEMS<sup>1</sup>

P. Thoft-Christensen

Aalborg University, Aalborg, Denmark

### 1. INTRODUCTION

Obtaining and maintaining advanced infrastructure systems plays an important role in modern societies. Developed countries have in general well established infrastructure systems but most non-developed countries are characterized by having bad or no effective infrastructure systems. Therefore, in the transition from a non-developed country to a well developed country construction of effective infrastructure systems plays an important role. However, it is a fact that construction of new infrastructure systems as well as maintaining existing systems requires great investments so a careful planning of all details in the system is essential for the effectiveness of the system from an operational but also economical point of view.

Most of the infrastructure systems (highways, bridges, harbours, railways etc.) built in Europe in the past seventy years was designed on the basis of a general belief among engineers that the durability of the materials used could be taken for granted. Although a vast majority of infrastructure systems have performed satisfactorily during their service life, numerous instances of distress and deterioration have been observed in recent years. The causes of deterioration of e.g. reinforced concrete bridges, piers etc. are often related to durability problems of the composite material. One of the most important deterioration processes which may occur in reinforced concrete bridges is reinforcement corrosion, caused by chlorides present in de-icing salts and/or carbonation of the concrete cover zone.

This paper is mainly based on Thoft-Christensen [5], [27], [32], Thoft-Christensen et al. [6], and de Brito et al. [7].

---

<sup>1</sup> Course-Workshop on “Optimal Bridge Maintenance Based on Risk and Reliability”, Toluca, Mexico, August 11-13, 2008.

## **2. BRIDGE MANAGEMENT SYSTEMS**

In this paper bridge management systems are discussed with special emphasis on management systems for reinforced concrete bridges. Management systems for prestressed concrete bridges, steel bridges, or composite bridges can be developed in a similar way.

Present bridge management systems are in most cases based on a deterministic approach and the assessment of the reliability or the safety is therefore in general based on subjective statements. In future bridge management systems we will see a change to stochastically based systems with rational assessment procedures. Future management systems will be computerized and different types of knowledge based systems will be used. Further, recent developments in non-linear optimization techniques will make it possible to produce a much better decision tool regarding inspection and repair.

It is beyond the scope of this paper to give a complete presentation of existing bridge management systems. Most existing management systems are presented in detail in the literature. In this paper a number of changes which are expected in future management systems will be discussed. A survey of existing systems is given by Casas [1], Chase [2], Das [3], and Roberts [4].

For many years it has been accepted that steel bridges must be maintained due to the risk of corrosion of steel girders etc. The situation is a little different for reinforced concrete bridges. Reinforced concrete bridges built in Europe in the past seventy years were designed on the basis of a general belief among engineers that the durability of the composite material could be taken for granted. Although a vast majority of reinforced concrete bridges have performed satisfactorily during their service life, numerous instances of distress and deterioration have been observed in such structures in recent years. The causes of deterioration of reinforced concrete bridges are often related to durability problems of the composite material. One of the most important deterioration processes which may occur in reinforced concrete bridges is reinforcement corrosion, caused by chlorides present in de-icing salts and/or carbonation of the concrete cover zone.

## **3. FUTURE BRIDGE MANAGEMENT SYSTEMS**

### **3.1 Introduction**

Future advanced bridge management systems will be based on simple models for predicting the residual strength of structural elements. Improved stochastic modelling of the deterioration is needed to be able to formulate optimal strategies for inspection and maintenance of deteriorated reinforced concrete bridges. However, such strategies will only be useful if they are also combined with expert knowledge. It is not possible to formulate all expert experience in mathematical terms. Therefore, it is believed that future management systems will be expert systems or at least knowledge-based systems.

Methods and computer programs for determining rational inspection and maintenance strategies for concrete bridges must be developed. The optimal decision should be based on the expected benefits and total cost of inspection, repair, maintenance and complete or partial failure of the bridge. Further, the reliability has to be acceptable during the expected lifetime.

### 3.2 EU-project 1990

The first major research on combining stochastic modelling, expert systems and optimal strategies for maintenance of reinforced concrete structures was sponsored by EU in 1990 to 1993. The research project is entitled “*Assessment of Performance and Optimal Strategies for inspection and Maintenance of Concrete Structures Using Reliability Based Expert systems*”. The results are presented in several reports and papers; see e.g. Thoft-Christensen [5], [8] and de Brito et al. [7]. The methodology used in the project is analytic with traditional numerical analysis and rather advanced stochastic modelling.

### 3.3 HA-project 1995

Monte Carlo simulation has been used in decades to analyse complex engineering structures in many areas, e.g. in nuclear engineering. In modelling reliability profiles for reinforced concrete bridges Monte Carlo simulation seems to be used for the first time in December 1995 in the Highways Agency project “*Revision of the Bridge Assessment Rules based on Whole Life Performance: Concrete*” (1995-1996, Contract: DPU 9/3/44, Project Officer: P.C. Das). The project is strongly inspired of the above-mentioned EU-project. The methodology used is presented in detail in the final project report by Thoft-Christensen & Jensen [9].

### 3.4 HA-project 1998

In the Highways Agency project “*Optimum Maintenance Strategies for Different Bridge Types*” (1998-2000, Contract: 3/179, Project Officer: N. Haneef) the simulation approach was extended in December 1998 by P. Thoft-Christensen [10], [11] to include stochastic modelling of rehabilitation distributions and preventive and essential maintenance for reinforced concrete bridges. A similar approach is used in the project by D.M. Frangopol [12] on steel/concrete composite bridges.

### 3.5 HA-project 2001

In a recent project “*Preventive Maintenance Strategies for Bridge Groups* (2001-2003, Contact 3/344 (A+B), Project Officer V. Hogg) the simulation technique is extended further to modelling of condition profiles, and the interaction between reliability profiles and condition profiles for reinforced concrete bridges, and the whole life costs. The simulation results are detailed presented by Frangopol [13], Thoft-Christensen & Frier [14], and Thoft-Christensen [15].

Many authors have published a large number of reports and papers on this subject in the last decade. A number of improvements, additions and modifications are described in this literature. However, the Highways Agency projects have played a major role in this development.

## 4. ESTIMATION OF LIFE CYCLE COST BENEFIT (LCCB)

During the last 20 years important progress has been made in Life-Cycle Cost (LCC) analysis of structures, especially offshore platforms, bridges and nuclear installations. Less work has been done on Life-Cycle Cost Benefit (LCCB) analysis. User costs and environmental costs are usually not included in LCC analysis while at least user costs are always included in LCCB analysis.

Due to the large uncertainties related to the deterioration and maintenance of such structures, analysis based on stochastic modeling of significant parameters seems to be the only relevant modeling. However, a great number of difficulties are involved in this modeling, but also in the practical implementation of the models developed. The main purpose of this section is to discuss these problems from a social point of view.

LCCB analysis may be used not only in the design of new bridges, but also in designing maintenance strategies for individual structures as well as groups of bridges. Therefore, several potential applications are obvious. However, it is a fact that only a few real applications of LCC or LCCB in bridge engineering are reported in the literature; see Thoft-Christensen [16].

To understand why LCC or LCCB is seldom used in bridge engineering, it is necessary to look at the modelling techniques used. In planning maintenance budgets for e.g. highway agencies the total expected costs for a group of bridges must be estimated and minimized. There are several models available in the literature, but most of them are similar to the modelling presented in section 5. The situation is quite different and more complicated if only a single bridge is considered whether LCC or LCCB design of a new bridge or maintenance of an existing bridge is considered. The most complete modelling seems to be the modelling presented in section 7.

Why is LCCB not used in bridge engineering? There are many reasons, but the main reason seems to be that the bridge engineers do not at all understand the probabilistic concepts behind LCCB. It is certainly not enough to have taken a course on probability theory or in structural reliability theory. What is needed is first of all a deep understanding of the advantages on using LCCB.

It is very hard to convince an experienced structural engineer that a stochastic approach to safety is more relevant than a deterministic approach to modeling uncertainties. Even to-day many structural engineers feel more confident with a traditional approach. Also notice that modern codes using partial safety coefficients are deterministic although the calibration is often based on stochastic modeling of the relevant parameters.

## 5. MODELLING OF LIFE CYCLE COST BENEFIT (LCCB)

### 5.1 Introduction

A large number of models for LCCB of groups of structures have been proposed in recent years. These models are usually based on an estimate of the LCCB where the expected initial costs  $C_{IN}$ , the expected failure costs  $C_F$ , the expected maintenance costs  $C_M$  and the expected user costs  $R_U$  are simply added

$$LCCB = C_{IN} + C_F + C_M + C_U \quad (1)$$

The single terms in this equation have been discussed by numerous researchers, and more and more sophisticated models have been developed. The state of the art is now so advanced that one would believe that it is straightforward to use these models in the future. However, it seems fair to say that LCCU design has until now been used in few cases only in bridge engineering. If the term  $R_U$  is deleted in (1) then an LCC analysis is performed.

### 5.2 Modelling LCCB for a large bridge stock

A bridge management system consists of a large number of different types of bridges. The objective of a bridge maintenance strategy is to minimize the cost of maintaining such a group of bridges in the service life of the bridge stock. Estimation of the service

life costs is very uncertain so that a stochastic modelling is clearly needed.

Let the number of bridges in the considered bridge stock be  $m$ . The expected total cost for the bridge stock can then be written; see Thoft-Christensen [15]

$$E[LCC] = \sum_{m \text{ bridges}} \left[ \sum_{\text{life-time } T, \text{ bridge } m} \left[ \sum_{\text{year } i, \text{ bridge } m} \text{costs} \right] \right] \quad (2)$$

$$= \sum_{j=1}^m \sum_{t=1}^T \left\{ (1+\gamma)^{-1} \left[ E[C_{Mi}(t)]P(M_{it}) + E[C_{Ui}(t)]P(U_{it}) + E[C_{Fi}(t)]P(F_{it}(t)) \right] \right\}$$

where

$E[C]$  is the expected total cost in the service life of the bridge stock,

$\gamma$  is the discount rate (factor), e.g. 6 %,

$E[C_{Mi}(t)]$  is the expected maintenance cost for bridge  $i$  in year  $t$ ,

$E[C_{Ui}(t)]$  is the expected user cost for bridge  $i$  in year  $t$ ,

$E[C_{Fi}(t)]$  is the expected failure cost for bridge  $i$  in year  $t$ ,

$P(M_{it})$  is the probability of the event “maintenance is necessary” for bridge  $i$  in year  $t$ ,

$P(U_{it})$  is the probability of the event “maintenance is necessary” for bridge  $i$  in year  $t$ ,

$P(F_{it})$  is the probability of the event “maintenance is necessary” for bridge  $i$  in year  $t$ ,

$T$  is the remaining service life or reference period (in years).

## 6. USER COSTS

### 6.1 Introduction

It is a fact that user costs are usually not included when optimal maintenance strategies and decisions are made, although authors often mention that user costs ought to be included. The life-cycle costs are minimized for the considered structure without considering the often significant costs for the users of the bridge and even without considering the long-term effects of the decision. Unfortunately, the maintenance decisions are often political decisions which are not easy to accept for the community. There is clearly a need to convince the decision-makers that user costs should be considered when major decisions are made; see Thoft-Christensen [19].

Life-Cycle Cost (LCC) analysis is in reality based only on the direct costs such as inspection and repair (preventive and essential) costs. Therefore, user costs are generally not included in an LCC analysis. However, Life-Cycle Cost-Benefit (LCCB) analysis is an extended LCC analysis where all kinds of indirect costs such as user costs are included.

To illustrate the importance on including user costs in an LCCB bridge management system, a brief review of a few reports is presented in this section. Notice, that in these reports user costs are modeled deterministically although user costs are always very uncertain. Therefore, user costs should in the future be modeled by stochastic variables or stochastic processes to obtain a rational modeling. However, a deterministic modeling based on statistic documentation is a good starting point for a stochastic modeling of user costs.

## 6.2 Report 1

The following excerpts are taken from the Highway Bridge section of a technical report entitled “Corrosion Cost and Preventive Strategies in the United States”, see Koch et al. [20]. The project is sponsored by the Federal Highway Administration.

“There are 583,000 bridges in the United States (1998). Of this total, 200,000 bridges are steel, 235,000 are conventional reinforced concrete, 108,000 bridges are constructed using prestressed concrete, and the balance is made using other materials of construction. Approximately 15 percent of the bridges are structurally deficient, primarily due to corrosion of steel and steel reinforcement. The annual direct cost of corrosion for highway bridges is estimated to be \$8.3 billion, consisting of \$3.8 billion to replace structurally deficient bridges over the next ten years, \$2.0 billion for maintenance and cost of capital for concrete bridge decks, \$2.0 billion for maintenance and cost of capital for concrete substructures (minus decks), and \$0.5 billion for maintenance painting of steel bridges. Life-cycle analysis estimates indirect costs to the user due to traffic delays and lost productivity at more than ten times the direct cost of corrosion maintenance, repair, and rehabilitation.”

“Overall, approximately 15 percent of all bridges are structurally deficient, with the primary cause being deterioration due to corrosion. The mechanism is one of chloride induced corrosion of the steel members, with the chlorides coming from de-icing salts and marine exposure.”

It is interesting to notice that Koch et al. [20] estimate the user costs due to traffic delays and lost productivity to be more than ten times the direct cost of maintenance, repair, and rehabilitation. User costs are here estimated as the product of additional travel time and the value of time.

## 6.3 Report 2

Next consider some excerpts from a research report of a project entitled “Strategic review of bridge maintenance costs”; see Maunsell [21]. The report is produced by Maunsell Ltd., UK for the Highways Agency, London, UK.

“A strategic review has been undertaken of annual maintenance costs of the Highways Agency’s structures. ... The object of the exercise was to predict the annual expenditure on essential and preventive maintenance which will be required in each of the next forty years on the Highways Agency’ bridge stock”.

“Road user delay costs due to maintenance were also estimated. These ranged from relatively small amounts to over ten times the direct maintenance costs, depending on the work being done and the type of road. However, the results are very sensitive to the assumptions used and only give a broad indication of likely delay costs”.

“If essential maintenance were underfunded, bridges would, in time, need to be closed or restricted while awaiting repair. The main effect would be road user delay costs of the order of £4.6 million a year for each £1 million of essential maintenance not undertaken. The review showed that the cumulated effects of such under funding would soon become unacceptable due to the disruption ...”

### 6.4 Report 3

On May 26, 2002 a barge slammed into the bridge on Interstate 40 over the Arkansas River near Webbers Falls, Oklahoma, USA; see Federal Highway Administration [22]. Four of the bridge's approach spans collapsed and fourteen people were killed. The bridge is the state's most important east-west transportation link, so the collapse had a major influence on the economy. The cost of repair of the bridge was about \$ 15 million and the total user cost was estimated to \$430.000 per day for every day the bridge was closed. It was therefore essential to accelerate the repair which was completed in about 2 month. \$12 million were spent on upgrading of the detour highways. The detours were used by approximately 17,000 vehicles every day the bridge was not open.

### 6.5 Report 4

Replacement of the Holcombe Flowage structure and the Fisher River structure on STH 27 in the Town of Lake Holcombe, WI, USA with two new concrete bridges is estimated to cost approximately \$ 2.43 million; see Schmidt [23]. The detour will be approximately 16 miles long. With a fuel cost of \$ 1.90 per gallon and a traffic volume of 4,500 cars per day, the fuel cost will be about \$ 2 million for a 6 – 8 month period.

### 6.6 Section conclusion

The importance of including user costs is clear from these studies. Therefore, a cost-benefit analysis is needed when life-cycle analysis of maintenance (including inspection cost, repair cost, and user cost) of bridges is performed. This conclusion is based on an extensive study of documents on maintenance costs. They are related to estimation of the importance of estimating user costs when repair of bridges are planned and when optimized strategies are formulated. These studies clearly show that user costs in most cases completely dominate the total costs. In some cases, the user costs are even more than ten times higher than the repair costs. Therefore an LCCB analysis is more reasonable to use.

There is an enormous amount of work on user costs in bridge engineering in the literature. However, much more research is needed before an LCCB analysis in the bridge area can be made in a satisfactory way. Much of the work done until now is limited to narrow models without a wide area of application. A reliable life-cycle based tool must include direct as well as indirect cost. The bridge owners must learn to listen to the public when decisions regarding repair or replacement of structures are taken.

## 7. MODELLING OF LIFE CYCLE COST BENEFIT (LCCB) FOR A SINGLE BRIDGE

For individual bridges LCCB may be used in designing a new bridge, but it is also very useful in connection with decision problems regarding e.g. repair after an inspection has taken place.

After a structural assessment at the time  $T_0$  a difficult problem is to decide if the bridge should be repaired and if so, how and when should it be repaired. After each structural assessment the total expected benefits minus expected repair and failure costs in the remaining lifetime of the bridge are maximized. This model can be used in an adaptive way if the stochastic model is updated after each structural assessment or



repair and a new optimal repair decision is taken. Therefore, it is mainly the time of the first repair after a structural assessment which is of importance.

In order to decide which type of repair is optimal after a structural assessment, the following optimization problem is considered for each repair technique; see Thoft-Christensen [5] and de Brito et al. [7]

$$\begin{aligned} \max W &= B(T_R, N_R) - C_R(T_R, N_R) - C_F(T_R, N_R) \\ \text{s.t. } \beta^U(T_L, T_R, N_R) &\geq \beta^{\min} \end{aligned} \quad (3)$$

where the optimization variables are the expected number of repair  $N_R$  in the remaining lifetime and the time  $T_R$  of the first repair.  $W$  is the total expected benefits  $B$  minus the repair costs  $C_R$  capitalized to the time  $t = 0$  and minus the expected failure costs  $C_F$  capitalized to the time  $t = 0$  in the remaining lifetime of the bridge.  $T_L$  is the expected lifetime of the bridge.  $\beta^U$  is the updated reliability index.  $\beta^{\min}$  is the minimum reliability index for the bridge.

The total expected benefits  $B$  includes the benefits for the bridge owners and the users minus the direct user costs due to maintenance activities. The benefits may be modelled by

$$B(T_R, N_R) = \sum_{i=[T_0]+1}^{[T_L]} B_i (1+r)^{T_0-T_{ref}} \frac{1}{(1+r)^{T_i-T_0}} \quad (4)$$

where  $[T]$  signifies the integer part of  $T$  measured in years and  $B_i$  are the benefits in year  $i$ .  $T_i$  is the time from the construction of the bridge. The  $i^{\text{th}}$  term in (4) represents the benefits from  $T_{i-1}$  to  $T_i$ . The benefits in year  $i$  may e.g. be modelled by

$$B_i = k_0 V(T_i) \quad (5)$$

where  $k_0$  is a factor modelling the average benefits for one vehicle passing the bridge. It can be estimated as the price of rental of an average vehicle/km times the average detour length. The reference year for  $k_0$  is  $T_{ref}$ . It is assumed that bridges are considered in isolation. Therefore, the benefits are considered as marginal benefits by having a bridge (with the alternative that there is no bridge, but other nearby routes for traffic).  $V$  is the traffic volume per year estimated by

$$V(T) = V_0 + V_1(T - T_{ref}) \quad (6)$$

where  $V$  is the traffic volume per year at the time of construction,  $V_1$  is the increase in traffic volume per year, and  $T$  is the actual time (in years).

The expected repair costs capitalized to time  $t = 0$  are modelled by

$$C_R(T_R, N_R) = \sum_{i=1}^{N_R} (1 - P_F^U(T_{R_i})) C_{R_0}(T_{R_i}) \frac{1}{(1+r)^{T_{R_i}-T_0}} \quad (7)$$

$P_F^U(T_R)$  is the updated probability of failure in the time interval  $[T_0, T_R]$ . The factor  $(1 - P_F^U(T_{R_i}))$  models the probability that the bridge has not failed at the time of repair.  $r$  is the discount rate.  $C_{R_0}(T_{R_i})$  is the cost of repair and consists of the three terms, namely the functional repair costs, the fixed repair costs, and the unit dependent repair costs, respectively.

The capitalized expected costs due to failure are determined by

$$C_F(T_R, N_R) = \sum_{i=1}^{N_R+1} C_F(T_{R_i})(P_F^U(T_{R_i}) - P_F^U(T_{i-1})) \frac{1}{(1+r)^{T_{R_i}}} \quad (8)$$

The  $i^{\text{th}}$  term in (8) represents the expected failure costs in the time interval  $]T_{R_{i-1}}, T_{R_i}]$ .  $C_F(T)$  is the cost of failure at the time  $T$ .

## 8. RELIABILITY AND CONDITION BASED MANAGEMENT SYSTEMS

The state of a bridge, the reliability of a bridge, and the condition of a bridge are defined and two models of the state of a bridge including its reliability and condition are included.

In the first approach the reliability and the condition are treated separately, but combined when decisions regarding bridge management (inspection and repair) are made. This approach is very useful when a single bridge is analyzed. The reliability is formulated by the now classical methodology based on stochastic modeling of significant quantities such as loads, strengths etc. The condition is taken into account using a knowledge-based approach obtained by expert knowledge. This methodology is discussed in detail in the paper on the basis of research done in an EU-supported project; Thoft-Christensen [28].

The second approach is based on integration of the reliability and the condition and is very useful when statistical information is available. In this approach the state of the bridge as a function of time is estimated by simple Monte Carlo simulation where the reliability profile (reliability as a function of time) is modified when condition related activities are taking place. This methodology is discussed in detail in the paper on the basis of research supported by the Highways Agency in London, Thoft-Christensen & Frier [29].

## 9. THE EU RESEARCH PROJECT

In this project methods and computer programs for determining rational inspection and maintenance strategies for concrete bridges is developed. The optimal decision is based on the expected benefits and total cost of inspection, repair, maintenance and complete or partial failure of the bridge. Further, the reliability has to be acceptable during the expected lifetime.

### 9.1 Classification of bridge inspection

In this project inspections of bridges are divided into three types:

- *Current inspections*, which are performed at a fixed time interval, e.g. 15 months. The inspection is mainly a visual inspection.
- *Detailed inspections* are also performed at a fixed time interval. The detailed inspections are also visual inspections. The inspections can also include non-destructive in-situ tests.
- *Structural assessments* are only performed when a current or detailed inspection shows some serious defects, which require a more detailed investigation. Thus structural assessments are not periodical inspections. The structural assessment can include laboratory tests, in-situ tests with non-portable equipment, static and dynamic load tests.

## 9.2 Maintenance and repair systems

The decision system, which is used to assist in maintenance and repair planning, is divided into two subsystems:

- The *maintenance subsystem* deals with maintenance repair techniques and small repair i.e. repair of unimportant structural defects. Generally, this subsystem is always used after a current or detailed inspection.
- The *repair subsystem* helps choosing the best option of structural repair when an important deficiency that impairs the functionality of the bridge is detected. It is basically an economic decision. Generally this subsystem is used after a structural assessment.

## 9.3 Inspection, maintenances, and repair strategies

The application of the expert system modules in the general inspection, maintenance and repair model from inspection no.  $i$  at the time  $t_i$  to inspection no.  $i+1$  at the time  $t_{i+1}$  is shown in figure 1, where the symbols used are: C/D is current or detailed inspection, A is structural assessment, M is maintenance work and repair of minor defects, R is repair, B1 is

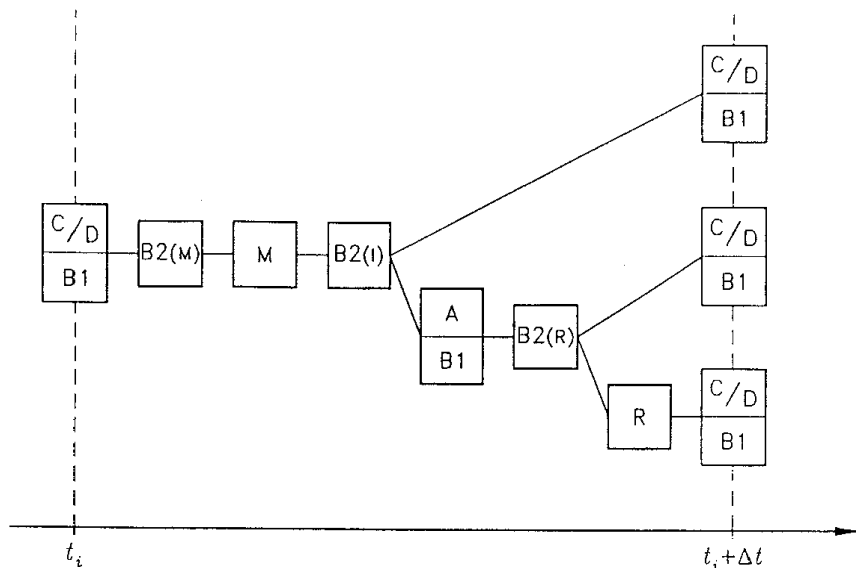

Figure 1. Application of inspection, maintenance, and repair

use of the expert system module BRIDGE1, B2 is use of the expert system module BRIDGE2. B2(M) is the maintenance/small repair submodules, B2(I) is the inspection strategy sub- module, and B2(R) is the repair sub module.  $\Delta t$  is the time between the periodic inspections.

After a current or detailed inspection there are two possibilities: the next inspection after  $\Delta t$  years is a current or a detailed inspection according to the inspection plan or the next inspection is a structural assessment to be performed immediately after the periodic inspection. The quality control inspection after a repair is not included in the modeling. After the structural assessment the repair decision is made.

### 9.4 The expert module BRIDGE2

The main functions of the expert system module BRIDGE2 are:

- After a *current or detailed inspection* maintenance work is planned by the submodule BRIDGE2(M). The decision is based on a classification of the defects based on three factors: rehabilitation urgency, structural importance and affected traffic. According to the inspector's experience and some pre-fixed rules, each defect is given a classification, which corresponds to a global number of deficiency points.
- After a *current or detailed inspection* it is decided if a structural assessment has to be performed before the next periodic inspection. The decision is based partly on estimates of the reliability of the bridge and partly on expert knowledge.
- After a *structural assessment* it is decided if repair work has to be performed and the time for the repair. The decision is partly based on expert knowledge and partly on a cost-based optimization where different repair possibilities and no repair are compared.

### 9.5 The optimal repair time

After a structural assessment at the time  $T_0$  the problem is to decide if the bridge should be repaired and the time of repair. Solution of this optimization problem requires that all future inspections and repairs are taken into account. However, the numerical calculations are then very time-consuming. Therefore, some approximations are introduced:

- After each structural assessment the total expected benefits minus expected repair and failure costs in the remaining lifetime of the bridge are maximized considering only the repair events in the remaining lifetime.
- It is assumed that  $N_R$  repairs of the same type  $I_R$  are performed in the remaining lifetime. The first repair is performed at the time  $T_{R_1}$  and the remaining lifetime is performed at equidistant times at the time interval  $t_R = (T_L - T_{R_1}) / N_R$ , where  $T_L$  is the year corresponding to the expected lifetime of the bridge.

The above decision model can be used in an adaptive way if the stochastic model is updated after each structural assessment or repair and a new optimal repair decision is made. Therefore, it is mainly the time and type of the first repair after a structural assessment, which is of importance.

In order to decide which repair type (including no repair) and repair time to choose after a structural assessment, the following optimization problem is considered with three optimization variables, namely: the type of repair  $I_R$  (including no repair); the time  $T_{R_1}$  of the first repair; the total number of repairs  $N_R$  in the remaining lifetime of the bridge.

$$\begin{aligned} \max_{I_R, T_{R_1}, N_R} C_T(I_R, T_{R_1}, N_R) &= B(I_R, T_{R_1}, N_R) - C_R(I_R, T_{R_1}, N_R) - C_F(I_R, T_{R_1}, N_R) \\ \text{s.t. } \beta^U(T_L, I_R, T_{R_1}, N_R) &\geq \beta^{\min} \end{aligned} \quad (9)$$

where  $C_T$  is the total expected benefits minus costs in the remaining lifetime of the bridge.  $B$  is the expected benefit in the remaining lifetime of the bridge.  $C_R$  is the expected repair cost in the remaining lifetime of the bridge.  $C_F$  is the expected failure cost in the remaining lifetime of the bridge.  $T_L$  is the year at the end of its expected lifetime.  $\beta^U$  is the updated reliability index.  $\beta^{\min}$  is the minimum acceptable reliability index for the bridge.

## 9.6 Application of the expert system

The objective of the project is to apply the expert system to real bridges. Therefore, the system is tested on two Portuguese and two Danish reinforced concrete bridges.

At first a small Portuguese bridge built with pre-cast girders was selected. This type of bridges has been largely employed, especially for short and medium-span viaducts or overpasses. They consist of precast girders and in-situ built deck slabs. The advantages of this bridge for testing the expert system arise from the fact that its construction was well controlled, the bridge was fully instrumented, and load tests were performed to analyze its structural behavior. The bridge was built in 1990 and it has been periodically inspected for deterioration. The bridge not expected to have important deterioration problems. The second Portuguese bridge is an old reinforced concrete arch structure built in 1940 with significant corrosion problems. Several tests, included in a structural assessment, were performed, and the results were used to check the two expert systems BRIDGE1 and BRIDGE2. At this stage the inspection recommendations obtained within BRIDGE1 were quite satisfactory.

The first of the Danish bridges is a beam-slab bridge built in 1921 and enlarged in 1936 to the double width. The bridge is a three-span structure with a total length of 33 m. The superstructure is supported at the ends and by two intermediate columns. Information about the bridge is based on an inspection report from a structural assessment made in 1988. During the inspection severe reinforcement corrosion was observed. The main cause of corrosion was carbonization. The chloride content in the bridge was not serious. The second Danish bridge is a beam-slab bridge built in 1945. In 1962 a complete overhaul of the bridge was performed. The superstructure is supported at the ends and by one intermediate column. The column cannot be analyzed by the expert system due to the materials used. Information about the bridge is based on an inspection report from a structural assessment made in 1988.

## 9.7 Implementation of the expert system

The main purpose of a first prototype of BRIDGE1 was to implement the correlation matrices. The correlation matrices were defined for: defects/diagnosis methods, defects/causes and defects/repair methods. A pseudo-quantitative classification of the types: no correlation, low, and high correlation was proposed. The correlation between defects and both diagnosis and repair methods were presented. Each matrix is organized so that each line represents a defect and each column represents a possible diagnosis/method, cause or repair method. At the intersection of each line and column a number representing the correlation between defect and possible element of reference is to be introduced.

BRIDGE1 is divided into five main blocks: general information about the concrete bridge, related diagnosis methods, probable causes, associated defects and provisional defect report. A crucial task in the development of the expert systems is the definition of the databases. Therefore, an extensive study of the comprehensive data related to concrete bridges, both at the design stage and after it has been built is made. All relevant events in the service life of the bridges are carefully described. In this database, the set of parameters required for the reliability estimation, the cost optimization, and additional bridge parameters concerning bridge repair cost and corrosion parameters are included.

The architecture of the expert system BRIDGE2 includes the following three modules: a database; an inspection module; and a decision module. The expert systems

are related to six typical corrosion related defects: rust stain, delamination/spalling, crack over/under a bar, exposed bar, corroded bar and bar with reduced cross-section.

## 10. THE LONDON HIGHWAY AGENCY RESEARCH PROJECT

### 10.1 Introduction

In this research project results from crude Monte Carlo simulations of the following five preventive maintenance strategies for underbridges are obtained; Thoft-Christensen [30]:

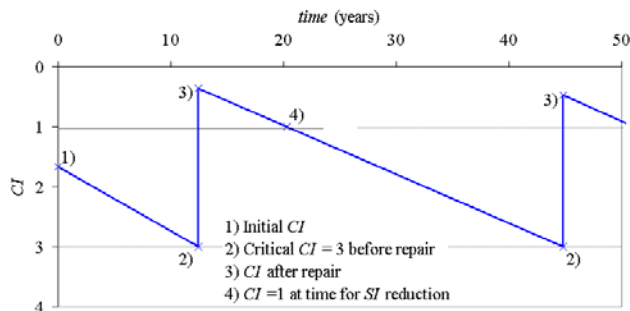

Figure 2. A realization of the condition index  $CI$  for the minor concrete repair strategy.

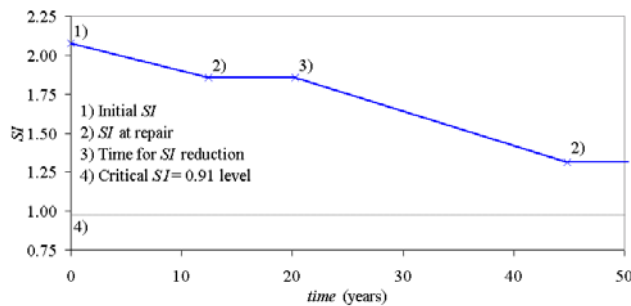

Figure 3. A realization of the safety index  $SI$  for a minor concrete repair strategy.

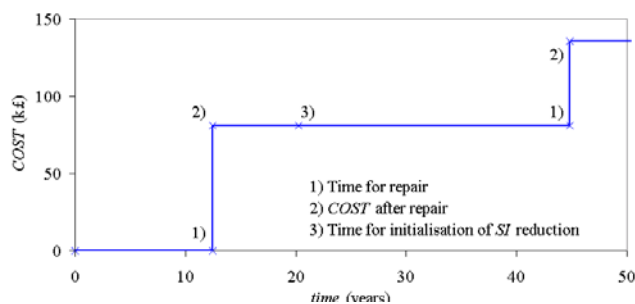

Figure 4. A realization of the cost for a minor concrete repair strategy.

- a. Minor concrete repairs
- b. Silane proactive preventive maintenance
- c. Do nothing & rebuild
- d. CP, with no associated repair
- e. Replace expansion joints.

However, in this paper only the detailed results for the minor concrete repair strategy are presented. The study is deterministic in the sense that no stochastic modeling is used. All relevant parameters are given by statistical distributions. A more up-to-date study is a stochastic approach where the initial safety state is based on the failure probability, where the time for deterioration initiation as well as the deterioration rate is based on a stochastic modeling.

No sensitivity studies have been performed. However, a satisfactory sensitivity study can be made simply by modifying the relevant data and redo the simulations. The discount rate used is 0 %, but any other value can easily be introduced.

## 10.2 Data collection and strategy assumptions

The simulations are primarily based on data received from Denton [31]. A few extra data are included to make the data set complete. These extra data and assumptions are not the same for all strategies.

The costs of the strategies are compared in section 9.6. The very wide spreading is primarily due the difference in repair costs, but also to some degree due to the different assumptions made. It is also important to bear in mind when comparing the costs that essential maintenance costs are not included.

The first SI downcrossing ( $SI=0.91$ ) distributions (first rehabilitation distributions) for all five strategies are compared in section 3.6. It is interesting to observe that they are very similar to rehabilitation distributions estimated in earlier research projects sponsored by the HA.

## 10.3 Realization of the condition index, the safety index and costs of the minor concrete repair strategy

The initial condition index CI is drawn from a triangular distribution with (minimum mean, maximum) = (0, 1.75, 3.5) conditioned on  $CI < 3$ . The approach is only valid for  $CI < 3$ . The deterioration slopes of CI (initial and after repair) is drawn from a triangular distribution ( $0 \text{ year}^{-1}$ ,  $0.08 \text{ year}^{-1}$ ,  $0.16 \text{ year}^{-1}$ ). Repair is undertaken when CI reaches an upper critical limit of 3. After repair CI is drawn from a triangular distribution (0, 1.75 3.5). A realization of the condition index CI for a minor concrete repair strategy is shown in figure 2.

The initial SI is drawn from a triangular (0.91, 1.5, 2.5) distribution. The deterioration slope of SI (initial and after  $CI = 1$ ) is drawn from a triangular distribution ( $0 \text{ year}^{-1}$ ,  $0.015 \text{ year}^{-1}$ ,  $0.035 \text{ year}^{-1}$ ). The SI slope immediately after repair is zero. When  $CI = 1$  is crossed, then the SI slope is changed from zero to the triangular distribution ( $0 \text{ year}^{-1}$ ,  $0.015 \text{ year}^{-1}$ ,  $0.035 \text{ year}^{-1}$ ). A realization of the safety index SI for a minor concrete repair strategy is shown in figure 3.

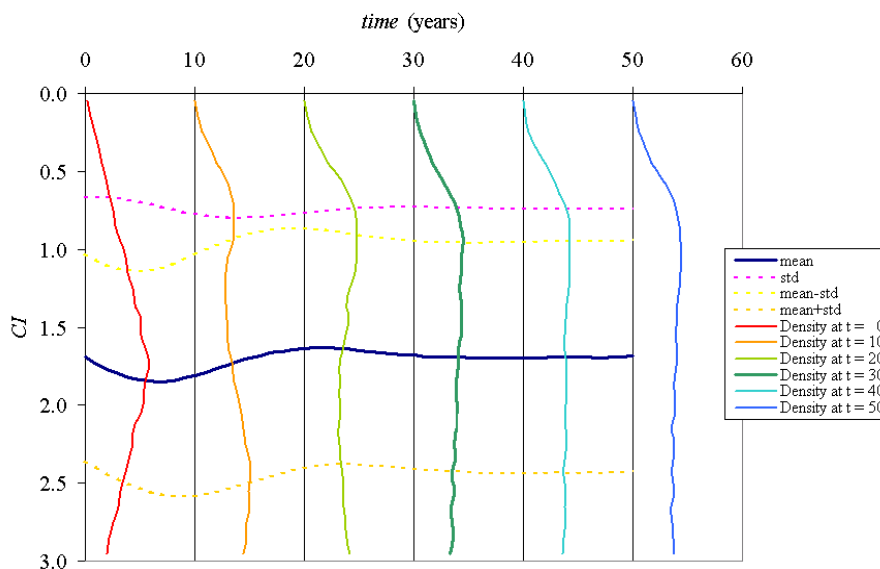

Figure 5. The condition index CI for the minor concrete repair strategy based on 50 000 simulations. Density functions are multiplied by a factor

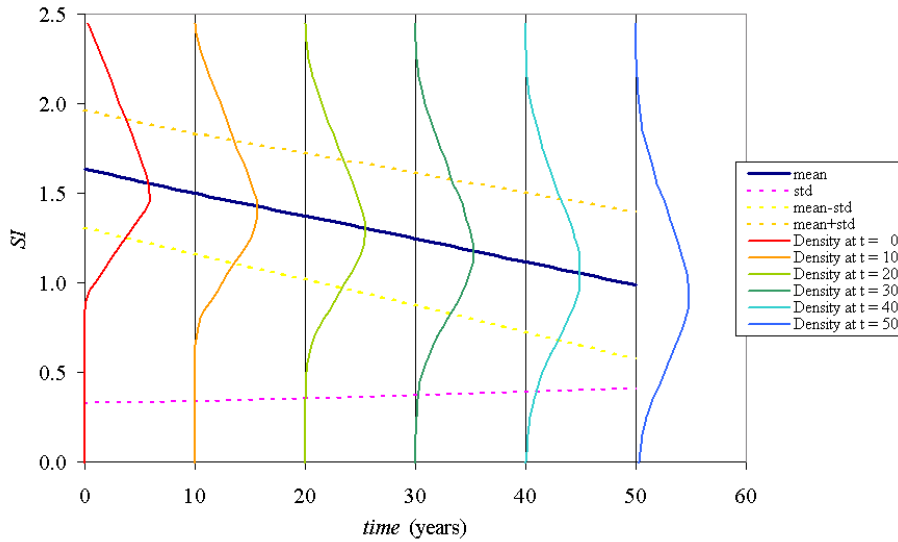

Figure 6. The safety index SI for the minor concrete repair strategy based on 50,000 simulations. Density functions are multiplied with a factor 5.

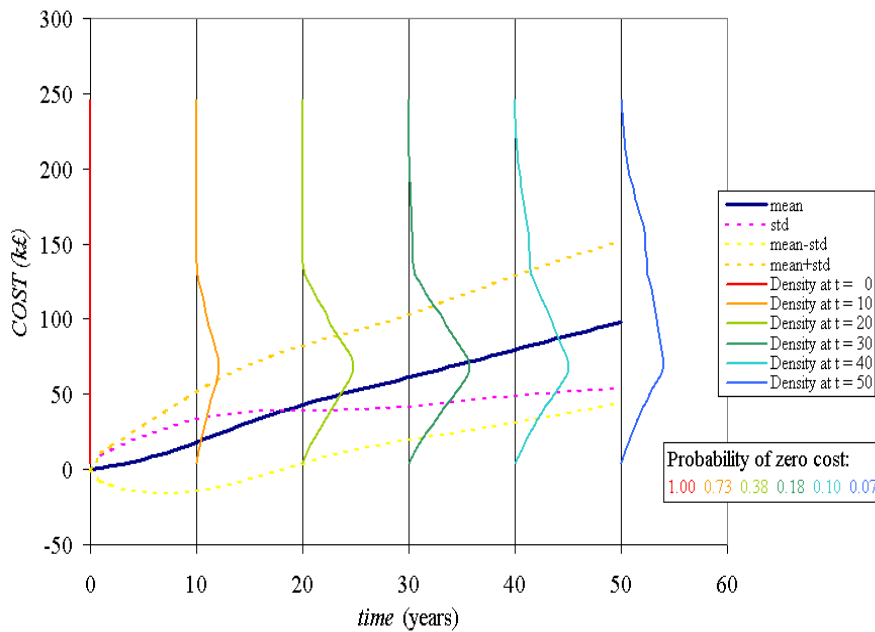

Figure 7. The cost for minor concrete repair strategy based on 50,000 simulations. Density functions are multiplied by a factor 500.

When repair is undertaken, the maintenance cost increment is drawn from the triangular distribution (6 k£, 68.5 k£, 131 k£). The discount rate is 0 %. A realization of the accumulated cost for a minor concrete repair strategy is shown in figure 4. Simulations are continued until  $SI < 0.91$  and time is larger than 50 years.

#### 10.4 Simulation results for the minor concrete repair strategy

The condition index CI at the times 0, 10, 20, 30, 40 and 50 years are shown in figure 5 when the minor concrete repair strategy is used. The data in figure 5 are based on 50,000 simulations. The similar statistics of the safety index SI and the cost are shown



in figures 6 and 7, respectively.

### 10.5 Density functions of the condition index CI, the safety index SI, and costs for the minor concrete repair strategy

The minor concrete repair approach is only valid for the 95.9 % best bridges. Simulations are performed based on the assumption that the initial condition index CI of the bridges is smaller than 3. Thus, the resulting statistics and distributions are conditioned on  $CI < 3$ .

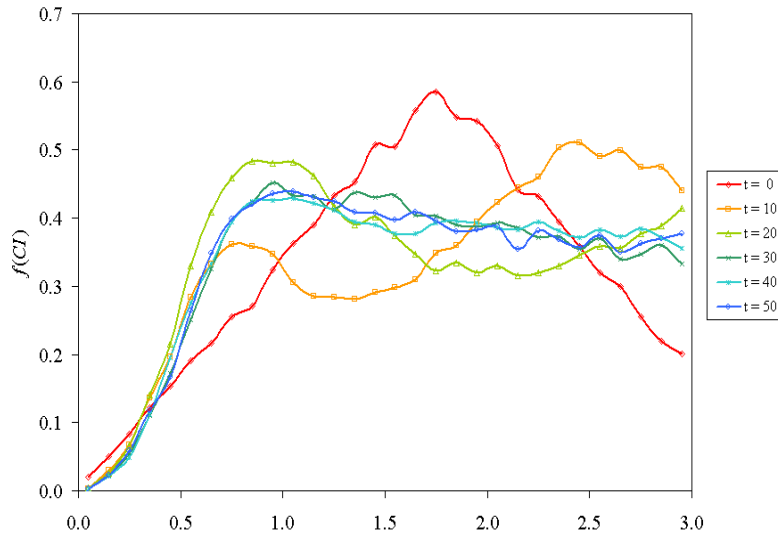

Figure 8. Density function of condition index CI for minor concrete repair strategy based on 50,000 simulations.

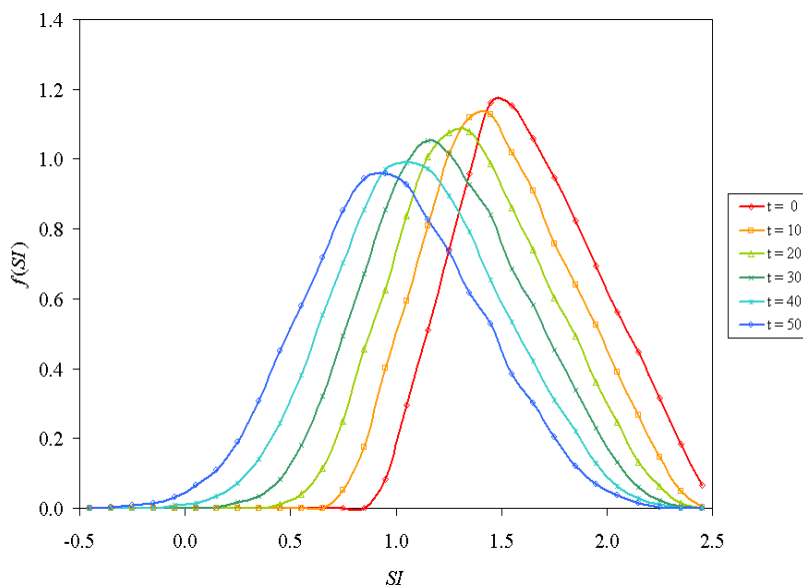

Figure 9. Density function of safety index for minor concrete repair strategy based on 50,000 simulations.

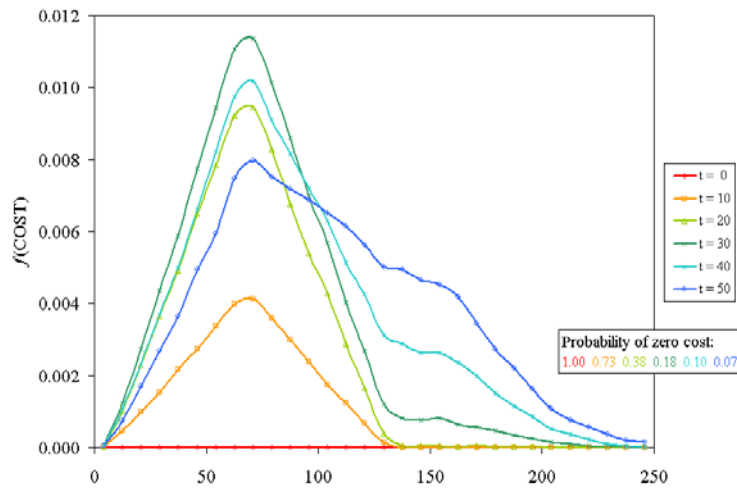

Figure 10. Density function of cost for minor concrete repair strategy based on 50,000 simulations.

A finite probability of zero cost is encountered during the simulations. Thus, the cost density function consists of a continuous and a discrete part. The continuous part is plotted in figures 7 and 10 and the discrete part is given as numbers in the figures.

Density functions of the condition index CI, of the safety index SI and the costs are shown in figures 8, 9, and 10, respectively.

### 10.6 Density functions for the first downcrossing

The density function for the first SI down at the critical level  $SI=0.91$  is shown in figure 11.

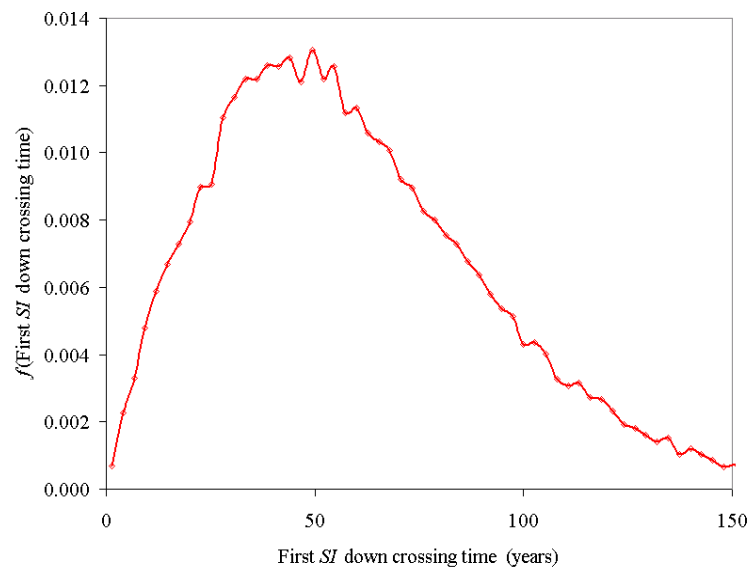

Figure 11. Density function of first SI downcrossing time for minor concrete repair strategy based on 50,000

### 10.7 Comparison of preventive maintenance costs for the five preventive maintenance strategies

In sections 9.2-9.5 results from the simulations are only shown for the preventive maintenance action called minor concrete repair. However similar results are also obtained for the remaining four preventive maintenance strategies mentioned above. In this section the results from all five strategies are compared. The five strategies are:

- Minor concrete repairs
- Silane proactive preventive maintenance
- Do nothing & rebuild
- CP, with no associated repair
- Replace expansion joints.

Table 1 shows the sample means for the five strategies for 0, 10, 20, 30, 40, and 50 years.

Maintenance type	E[C] k£ 0 years	E[C] k£ 10 years	E[C] k£ 20 years	E[C] k£ 30 years	E[C] k£ 40 years	E[C] k£ 50 years
Minor concrete repairs	0	18	43	61	80	98
Silane	0	1	1	2	3	3
Do nothing & rebuild	0	12	48	100	155	208
CP	0	15	39	67	95	124
Replace expansion Joints	0	124	305	314	389	561

Table 1. Sample means of costs for different maintenance strategies based on 50,000 simulations.

A finite probability of zero cost is encountered during the simulations. Thus, the cost density function consists of a continuous part and a discrete part. The continuous part is plotted in figures 7 and 10 and the discrete part is given as numbers in the figures.

It follows from table 2 that Cathodic Protection (CP) has the lowest expected time to the first SI downcrossing of the critical value  $SI = 0.91$ , namely about 20 years.

Maintenance type	E[first SI down crossing time], years
Minor concrete repairs	61.24
Silane	56.81
Do nothing & rebuild	61.17
CP	20.71
Replace expansion joints	56.16

Table 2. Sample means of the first downcrossing times for different maintenance strategies based on 50,000 simulations.

The downcrossing times for the other four strategies are 50 – 60 years. Further, it follows from figure 12 that the downcrossing distributions for the same four strategies are similar while the downcrossing for CP is significantly different and with a much smaller standard deviation.

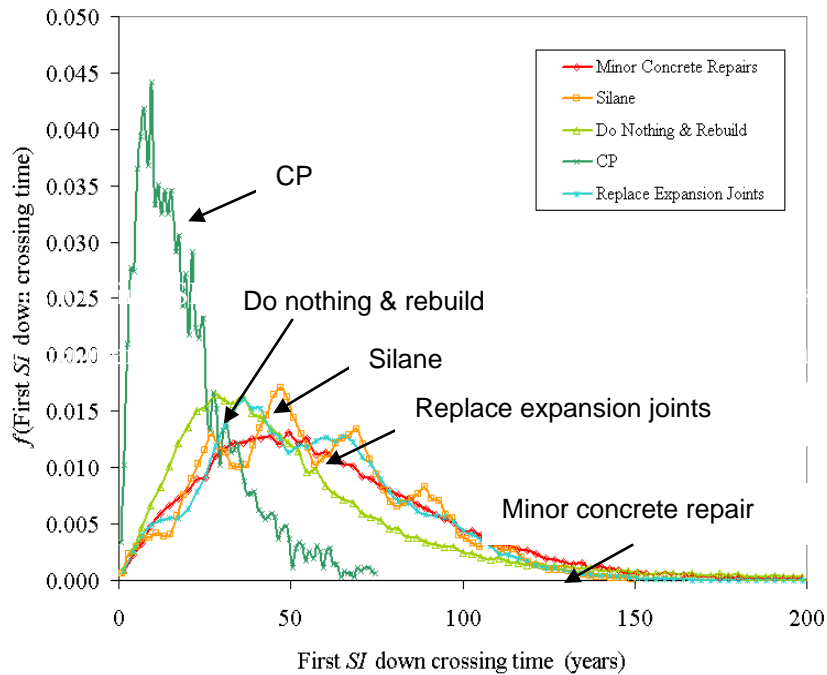

Figure 12. Comparison of first safety index SI downcrossing distributions (for CP strategy, only 3,535 realizations (7.07 %) had finite downcrossing).

## 11. EXPERT SYSTEMS

Expert systems technology is nowadays being considered as a powerful mechanism for helping human experts in their everyday decision tasks. Being able to represent in the computer system the knowledge structures and reasoning strategies that the human expert follows when approaching a problem, enables other users to share this knowledge and the expert system thus constructed establishes a common decision criterion for the prospective users of the system.

The objective of using expert system technology in bridge management is to produce a software tool to assist bridge inspectors as well as engineering experts in their tasks of assessing and improving the reliability of concrete bridges; see de Brito et al. [7] and Thoft-Christensen [17], [18].

The first step is to identify the various software subsystems and the relations between them i.e. the software architecture that will set the basis for the development of the expert systems. It is natural in bridge management to develop two different modules aimed at different goals. The first should provide technical support to the inspector during the inspection process at the bridge site. The second should assist the engineer in the analysis of the safety of bridges as well as in the selection of maintenance and repair methods.

A number of software modules will interact with the expert systems through specifically designed data files:

- *Updating analysis:* Based on inspection information and other new information the reliability estimates and the data in the databases must be updated.
- *Reliability analysis:* The reliability of the bridge must be evaluated as a function of time.
- *Structural analysis:* The system should be open so that the user is able to use his own finite element software.

- *Inspection program:* Based on the data in the databases and the reliability estimates the optimal time for the next inspection is calculated using the updating module.

The next step is to identify the representation schemes and inference mechanisms best suited for the implementation of the expert systems, as well as the evaluation and selection of the most promising expert system shells available that would guarantee that the representation and inference requirements identified are fulfilled. The functional interrelations between the expert modules and the analysis programs must be defined.

In bridge management it is convenient to have at least two systems, namely one to be used in the inspection phase and one to be used during maintenance and for repair decisions. In such a case the first system will be highly based on “correlation matrices”. Correlation matrices must be defined for: defects/diagnostic methods, defects/causes and defects/repair methods. A pseudo-quantitative classification of the type no correlation, low and high correlation is useful. Correlation between defects as well as diagnostic and repair methods is also needed. Each matrix must e.g. be organized so that each line represents a defect and each column a possible diagnosis method, cause or repair method. At the intersection of each line and column a number representing the correlation between defect and possible element of reference is to be introduced.

It is important for the applicability of the expert system that it gives all the information needed during and after inspections. Such information could be: general information about the bridge, related diagnostic methods, probable causes, associated defects and provisional defect report.

A crucial task in the development of expert systems is the definition of the databases. An exhaustive study of the data collected for concrete bridges, both at the design stage and after it has been constructed must be provided. At relevant moments of the bridge's service life (usually after construction and after important rehabilitation work is performed), its real situation must be thoroughly described so that future inspections have something to relate to. When the database definition is completed then the set of parameters required for the reliability estimation, the cost optimization, additional bridge parameters dealing with the bridge repair cost and corrosion descriptive parameters are added. Most existing bridge management databases are insufficient for e.g. reliability assessment and for implementing modern decision making tools.

A number of expert modules are needed to define the architecture of the expert system: database module, inspection module and a decision module. The decision module will in general be divided into a number of sub-modules such as: a maintenance/small repair submodule, an inspection strategy submodule and a repair/upgrading/replacement submodule.

In the expert systems a number of strategies must be implemented, such as: Should technical knowledge regarding the need to perform a structural assessment be incorporated into the system and should it also be used to double check when the reliability index estimates that the condition of the bridge is good?

The inspector must be able to perform activities like: Review all the information contained in the database of the bridges. Different types of data are recorded for each bridge: identification and bridge site information, design information, budget information, traffic information, strength information, load information, deterioration information, factors that model the costs and data for the cross-sections defined for the bridge.

The inspection engineer must at his office be able to e.g. view the inspection results recorded at any previous inspection performed in any of the bridges of the database.

## 12. DISCUSSION

Designing a new bridge or a bridge maintenance strategy based on LCCB will in general result in an apparently increased initial cost, so it is not attractive for Highways Agencies. This recognition in connection with the conservative tradition of only looking at the initial costs makes it unattractive to use LCCB.

A modern LCCB design is based on a probabilistic approach. Some of the terms in the cost equations are based on probabilistic distributions, expected values, etc. A bridge engineer not familiar with probability theory will be less prepared to accept designs based on a stochastic modeling. This is true not only for design of a bridge, but also for design of bridge maintenance strategies.

Bridge engineers often believe that the design of a new bridge or the repair of an existing bridge is 100% safe in the remaining service life of the bridge. Likewise, if you inform politicians that there is a failure probability of say  $10^{-6}$  you will often be asked whether failure could take place to-morrow. Your answer will probably be yes, it is possible but, unlikely. His reply could then easily be that he does not want the suggested design, but a 100% safe bridge. The conclusion is that we need to educate the general citizen but especially the decision-makers.

The public will is low, since designing a structure based on LCCB will result in an increased initial cost and could therefore give budget and re-election problems for the politicians.

The mathematical modeling is not complete, since there are relevant factors for the LCCB which may not be included in the model. Some minor repairs are often needed even if they are not directly important for the safety of the bridge. It may not always be possible to estimate the condition of the bridge in a rational way. Therefore, for some bridge engineers the concepts behind LCCB is not always acceptable. They feel that the modeling is in some way too complicated and detailed, but at the same time not complete.

It is obvious that using LCCB in bridge engineering will require a lot of reliable data which in many cases are not available. This is especially true when a single bridge is considered. In the case of a single bridge very good and comprehensive data regarding the condition of the bridge is needed. Using LCCB in such a case requires a bridge engineer not only familiar with probabilistic thinking, but also with a lot of experience.

The situation is perhaps a little easier for groups of bridges, since only average data is needed. Such data may to some extent be available in Highways Agency databases. For groups of bridges LCCB based strategies at level 1 may be the way ahead. However, the output of a level 1 modeling should not stand alone – it must be followed up by the knowledge of experienced bridge engineers.

In most countries user costs will be the dominating term in the modeling of LCCB, but they are not usually included in the modeling. The reason is that modeling user costs are problematic and difficult. However, this is not a reasonable argument for not taking user costs into consideration.

Some of the terms in the above-mentioned modeling of LCCB are strongly dependent on the discount rate. A high discount rate will make LCCB design less

important than a low discount rate. There is a clear tendency in most countries to use an unrealistically high discount rate. If this is so then using LCCB may be meaningless.

### 13. CONCLUSIONS

In the future we will see more and more applications of reliability based LCCB bridge management systems. Benefits (user cost) will play an important role in all future systems. Likewise, expert knowledge will be integrated into the systems.

Initially such advanced bridge management systems will be used in a small scale on a limited stock (perhaps only few) of bridges or on new bridges. The experience learned from such studies will be useful in defining areas where more research and data is needed.

A serious problem is that many bridge engineers do not appreciate the probabilistic concepts behind LCCB. The only solution to this problem seems to be to introduce the probabilistic concepts in the university courses in bridge engineering. There is also a great need for statistical data related to inspection and repair of reinforced concrete structures. Therefore, the national bridge databases should be modified to make them useful for designing and using modern bridge management systems.

### ACKNOWLEDGEMENT

Section 9 is based on the Final Technical Report and other working reports produced within the EU supported research project P3091 (BREU Contract 0186-C). The project partners are: CSR, Aalborg, Denmark (project coordinator); University of Aberdeen, Aberdeen, UK / Sheffield Hallam University, Sheffield, UK; Jahn Ingenieurbureau, Hellevoetsluis, Holland; Instituto Superior Técnico, Lisboa, Portugal; LABEIN, Bilbao, Spain.

The work presented in section 10 is a part of a research project supported by the Highways Agency in London, Contract 3/344B, project officer V. Hogg. The author wishes to thank D. Frangopol, University of Colorado, USA; S. Denton & R. Walker, Parsons Brinckerhoff Ltd, UK; N. Shetty, Atkins, UK; M. B. Roberts, Faber Maunsell Ltd, UK; and C. Middleton, Cambridge University, UK for good co-operation during this study.

### REFERENCES

- [1] Casas, J.R. Bridge Management – Actual and Future Trends. Proceedings (CD), IABMAS'06, Porto, Portugal. Belkema, 2006.
- [2] Chase, S.B. The Bridge Maintenance Programme of the United States Federal Highway Administration. Management of Highway Structures (Editor P.C. Das), Thomas Telford, 1999.
- [3] Das, P.C. Priorisation of Bridge Maintenance Needs. Case Studies in Optimal Design and Maintenance Planning of Civil Infrastructure Systems (Editor D.M. Frangopol), ASCE, 1999.

- [4] Roberts, J.E. Bridge Management for the 21<sup>st</sup> Century. Maintaining the Safety of Deteriorating Civil Infrastructures (Editors A. Miyamoto & D.M. Frangopol). Ube, Yamaguchi, Japan, 2001.
- [5] Thoft-Christensen, P. Advanced Bridge Management Systems. Structural Engineering Review, Vol. 7, 1995, 151-163 .
- [6] Thoft-Christensen, P., F.M. Jensen, C.R. Middleton & A. Blackmore Assessment of the Reliability of Concrete Slab Bridges, IFIP WG 7.5 Working Conference, Boulder, Co., USA, April 1996, pp.
- [7] de Brito, J., F.A. Branco, P. Thoft-Christensen & J. D. Sørensen. An Expert System for Concrete Bridge Management. Engineering Structures, Vol. 19, No. 7, 1997, pp. 519-526.
- [8] Thoft-Christensen, P. (editor). Assessment of Performance and Optimal Strategies for Inspection and Maintenance of Concrete Structures Using Reliability Based Expert systems. Report. CSRconsult ApS, Aalborg, Denmark, 2002.
- [9] Thoft-Christensen, P. & F.M. Jensen. Revision of the Bridge Assessment Rules based on Whole Life Performance: Concrete. Final Report, HA-project DPU 9/3/44, December 1996.
- [10] Thoft-Christensen, P. Estimation of Reliability Distributions for Reinforced Concrete Overbridges . HA-project 3/179, Working Document CSR-WD01, December 1998.
- [11] Thoft-Christensen, P. Optimum Maintenance Strategies for Different Bridge Types, Vol. 2, Concrete Bridges . Final Report, HA-project 3/179, January 2000.
- [12] Frangopol, D.M. Optimum Maintenance Strategies for Different Bridge Types, Vol. 1, Steel/Concrete Composite Bridges . Final Report, HA-project 3/179, January 2000.
- [13] Frangopol, D.M. Preventive Maintenance Strategies for Bridge Groups- Analysis, Vol.1. Final Report, HA-project 3/344(B), February 2003.
- [14] Thoft-Christensen, P. & C. Frier. Estimation of Preventive Maintenance Costs Using Simulation. HA-project 3/344(B), Report CSR-08, February 2003.
- [15] Thoft-Christensen, P. Preventive Maintenance Strategies for Bridge Groups- Analysis, Vol.2. Final Report, HA-project 3/344(B), February 2003.
- [16] Thoft-Christensen, P. Life-Cycle Cost Design – Why is it not being used? Proceedings (CD), IABMAS'04, October 19-22, 2004, Kyoto, Japan.
- [17] Thoft-Christensen, P. Reliability-Based Expert Systems for Optimal Maintenance of Concrete Bridges. Proc. ASCE Structures Congress'93, Irvine, California, USA, April 1993.



- [18] Thoft-Christensen, P. Assessment of Performance and Optimal Strategies for Inspection and Maintenance of Concrete Structures Using Reliability Based Expert Systems. ERSeDA Seminar, Charmonix, April 1994.
- [19] Thoft-Christensen, P. User Costs in Life-Cycle Cost-Benefit (LCCB) Analysis of Bridges. Proceedings IABMAS'06 Porto, Portugal, Belkema, 2006.
- [20] Kock, H.K., Brongers, M.P.H., Thompson, N.G., Virmani, Y.P. & Payer, J.H.. Corrosion Cost and Preventive Strategies in the United States. Report R315-01. CC Technologies Laboratories, Dublin, OH, USA and NACE Int., Houston, TX, USA. 2001, [www.corrosioncost.com](http://www.corrosioncost.com).
- [21] Maunsell 1999. Strategic Review of Bridge Maintenance Costs. Report on 1998 Review. HA project number: 980532/10, April 1999.
- [22] Federal Highway Administration 2002. Accelerated Bridge Repairs. Focus August 2002. U.S. Department of Transportation, FHA. [www.tfhr.gov/focus/aug02/0.1.htm](http://www.tfhr.gov/focus/aug02/0.1.htm).
- [23] Schmidt, B. STH 27 Bridge. Population Concern Report, January 31, 2005. [www.holcombebridge.com](http://www.holcombebridge.com).
- [24] Thoft-Christensen, P. What Happens with Reinforced Concrete Structures when the Reinforcement Corrodes? Proceedings of Int. Workshop on "Life-Cycle Cost Analysis and Design of Civil Infrastructure Systems", Yamaguchi University, Ube, Japan, 2001
- [25] Liu, Y. & Weyers, R.E. Modeling of the Time-to-Corrosion Cracking in Chloride Contaminated Reinforced Concrete Structures, ACI Materials Journal, Vol. 95, 1998, pp. 675-61.
- [26] Andrade, C., Alonso, C. & Molina, F.J. Cover Cracking as a Function of Bar Corrosion: Part 1 – Experimental Test. Materials and Structures, Vol. 26, 1993, pp. 453-464.
- [27] Thoft-Christensen, P. The Future of Life-cycle Cost Benefit Analysis. Proceedings 4 Jornadas de Engenharia de Estruturas (JPEE 2006), Lisbon, Portugal, 13-16 Dec. 2006, pp.28-45.
- [28] Thoft-Christensen P. (editor) 2002. Assessment of Performance and Optimal Strategies for Inspection and Maintenance of Concrete Structures Using Reliability Based Expert Systems, CSRconsult ApS, Denmark.
- [29] Thoft-Christensen, P. & Frier, C. 2003. Estimation of Preventive Maintenance Costs using Simulation. HA-project, Contract 3/344(B). Report CSR-08, CSRconsult ApS, Denmark.
- [30] Thoft-Christensen, P. 2003. Preventive Maintenance Strategies for Bridge Groups – Analysis – Vol.2. HA-project, Contract 3/344(B). Final Report.
- [31] Denton, S. 2003. Parsons Brinckerhoff Ltd, UK. Private communication.

- [32] Thoft-Christensen, P. 2003. Reliability and Condition Based Bridge Management Systems. Proceedings (CD) ICOSAR'05, Rome, Italy,2005, Millpress, 2005.ISBN 90 5966 040 4.

