



**AALBORG UNIVERSITY**  
DENMARK

**Aalborg Universitet**

## **Papers**

*Volume 8: 2008-2014*

Thoft-Christensen, Palle

*Publication date:*  
2014

*Document Version*  
Publisher's PDF, also known as Version of record

[Link to publication from Aalborg University](#)

*Citation for published version (APA):*  
Thoft-Christensen, P. (2014). *Papers: Volume 8: 2008-2014*. Department of Civil Engineering, Aalborg University.

### **General rights**

Copyright and moral rights for the publications made accessible in the public portal are retained by the authors and/or other copyright owners and it is a condition of accessing publications that users recognise and abide by the legal requirements associated with these rights.

- Users may download and print one copy of any publication from the public portal for the purpose of private study or research.
- You may not further distribute the material or use it for any profit-making activity or commercial gain
- You may freely distribute the URL identifying the publication in the public portal -

### **Take down policy**

If you believe that this document breaches copyright please contact us at [vbn@aub.aau.dk](mailto:vbn@aub.aau.dk) providing details, and we will remove access to the work immediately and investigate your claim.

## CHAPTER 146

# VARIANCE REDUCTION MONTE CARLO METHODS FOR WIND TURBINES<sup>1</sup>

M.T. Sichani, S.R.K. Nielsen & P. Thoft-Christensen  
Aalborg University, Aalborg, Denmark

### ABSTRACT:

Development of Variance Reduction Monte Carlo (VRMC) methods has proposed the possibility of estimation of rare events in structural dynamics. Efficiency of these methods in reducing variance of the failure estimations is a key parameter which allows efficient risk analysis, reliability assessment and rare event simulation of structural systems. Different methods have been proposed within the last ten years with the aim of estimating low failure probabilities especially for high dimensional problems. In this paper applicability of four of these methods i.e. Importance Sampling (IS), Distance Controlled Monte Carlo (DCMC), Asymptotic Sampling (AS) and Subset Simulation (SS) are compared to each other on a common problem. The aim of the study is to determine the most appropriate method for application on realistic systems, e.g. a wind turbine, which incorporate high dimensions and highly nonlinear structures.

### 1. INTRODUCTION

Assessment of reliability and design of highly nonlinear and high dimensional structures such as wind turbines require estimation of very low failure probabilities of the system. This task can be tackled from three different points of view. The first class of methods is the extreme value distribution fittings to the extracted data of a wind turbine (Caires & Sterl 2005, Mackay, Challenor, & Baha 2010). These data might be taken either from measured responses of a real wind turbine or from epochs of the response simulated by computer. This can be done in combination with some sampling methods such as the epochal method or the Peaks Over Threshold method (POT). It is implicitly assumed that the parent distribution belongs to the domain of attraction of one of the extreme value distributions; therefore the excess values above a

---

<sup>1</sup> Proceedings ICASP 11, Zurich, Switzerland, Aug. 01-08, 2011.

given threshold follow a Generalized Pareto (GP) distribution (Naess & Clausen 2001). The required failure probability will be extrapolated from the fitted distribution.

On the other hand the so-called Variance Reduction Monte Carlo simulations (VRMC) might be used for estimating the failure probabilities (Sichani, Nielsen, & Bucher a). The applicability and efficiency of the VRMC methods on wind turbines is the subject of this study in order to understand advantages and limitations of VRMC methods within the framework of wind turbines. The VRMC methods enable efficient estimation of the first excursion of the wind turbines within reasonable computation charge. However, they do not provide any means of understanding the evolution of the PDF of the process within time. This is of great interest since it gives a good insight into the statistical characteristics of the system and effect of different components, i.e. controller, on it.

Another approach for estimation of the first excursion probability of any system is based on calculating the evolution of the Probability Density Function (PDF) of the process and integrating it on the specified domain. Clearly this provides the most accurate result among the three classes of the methods. The Fokker-Planck-Kolmogorov (FPK) equation is a well-known tool for realizing the evolution of a stochastic process governed by a differential equation. Although solution of the FPK for even low order structural dynamic problems require excessive numerical computations. This confines the applicability of the FPK to a very narrow range of problems. On the other hand the recently introduced Generalized Density Evolution Method (GDEM), (Li & Chen 2009, Chen & Li 2009), has opened a new way toward realization of the evolution of the PDF of a stochastic process. It is an alternative to the FPK. The considerable advantage of the introduced method over FPK is that its solution does not require high computational cost which extends its range of applicability to high order structural dynamic problems.

## **2. ESTIMATION OF LOW FAILURE PROBABILITIES**

Estimation of failure probabilities of a wind turbine model is not a trivial task since it incorporates a highly nonlinear model for which the failure probability is to be estimated within long time duration e.g. 600s. However on the structure part, the wind turbine consists of a simple linear model, nonlinearities in such models appear from loading. These stem from two origins namely the nonlinear aerodynamic loads and the presence of a controller. The aerodynamic loads are highly nonlinear functions of the instantaneous wind speed and the pitch angles of the blades which are calculated with different means e.g. Blade Element Momentum theory (BEM) in this study. The pitch-controller introduces additional nonlinearities to the model i.e. due to its saturation state. Next according to the design criterions the barrier level of a specified failure probability, e.g.  $3.8 \times 10^{-7}$ , is required to be defined. This can most efficiently be estimated if the Cumulative Density Function (CDF) of the failure probability can be derived down to low failure probabilities of the order  $10^{-7}$ .

The focus of this paper is on the VRMC methods. Among the various available methods Importance Sampling (IS) (Bucher 2000, Au & Beck 2001, Macke & Bucher 2003), Distance Controlled Monte Carlo (DCMC) (Pradlwarter, Schueller, & Melnik-Melnikov 1994, Pradlwarter & Schueller 1997, Pradlwarter & Schueller 1999), Asymptotic Sampling (AS) (Bucher 2009, Sichani, Nielsen, & Bucher a, Sichani, Nielsen, & Bucher b), and Subset Simulation (SS) (Au & Beck 2001) are chosen primarily.

All of the methods aim at the same subject, i.e. estimation of the low failure probability events. However, they tackle the problem from very different points of view. IS moves the so-called sampling density of the problem to the boundaries of the failure region hence generates more samples in this area. DCMC works more on a logical basis where the idea is to run all the simulation samples simultaneously and find those processes which are closer to the boundaries of the safe domain and increase the outcrossing events by putting more emphasis on these important events. The AS development is based on the asymptotic estimation of failure probabilities (Breitung 1989). Here the advantage of the linear relationship of the safety index for multi-normal probability integrals is considered to estimate low failure probabilities by proper scaling of the probability integral. AS forces more outcrossing by increasing the excitation power. SS takes its basis on the conditional probability estimation. It breaks the problem of a low failure probability estimation into estimation of a multiplication of some higher probabilities. Next a conditional sampler i.e. Modified Metropolis-Hastings algorithm is used to estimate the conditional probabilities.

Primarily introduced methods are used for failure probability estimation of a Single Degree of Freedom (SDOF) oscillator. Comparison is made on the results of the methods in terms of their accuracy, requirements and computational load. Standard Monte Carlo (SMC) simulation for the same system is performed for global comparison of accuracy of the methods.

This study prevails advantages and disadvantages of each of the methods in application on dynamic systems. Next, the method with highest merit is chosen and applied on a wind turbine model developed in previous study c.f. figure 7.

### 3. IMPORTANCE SAMPLING

#### 3.1 Introduction

To apply IS (Macke & Bucher 2003) it is necessary to have estimation of the system responses at the failure time instance, i.e. displacements, when it is excited by the increments of the Wiener process. This estimation is the basis for constructing the so-called control functions which their characteristics are that they bring the system response to the failure state at failure time instance, i.e.  $t_k = k\Delta t$ , if the system is excited with them. Next, these deterministic drifts are added to the Wiener increments and the result is used as the final system excitation. Starting by designing control functions, if excitations are not Wiener increments themselves, they should be represented in terms of them. Suppose the system is described by the Ito SDE (1)

$$\left. \begin{aligned} d\mathbf{Z}(t) &= \boldsymbol{\mu}(t, \mathbf{Z})dt + \boldsymbol{\sigma}(t, \mathbf{Z})d\mathbf{W}(t) \\ \mathbf{Z}(s) &= \mathbf{z} \end{aligned} \right\} \quad (1)$$

where  $\mathbf{Z}(t)$  is p-dimensional system response subjected to the initial conditions  $\mathbf{Z}(s) = \mathbf{z}$  for any  $0 \leq s \leq T$  and  $\mathbf{W}(t)$  is the vector of q-dimensional unit Wiener processes. Given that the failure domain boundary is specified by the failure surface  $g(\mathbf{Z}(t), \mathbf{W})_- = 0$  such that

$$\mathcal{F} = \left\{ \mathbf{Z} \mid g(\mathbf{Z}) > 0 \right\} \quad (2)$$

using (1), (2) can be written in the terms of the Wiener excitation i.e.

$$\mathcal{F} = \{ \mathbf{W} \mid g(\mathbf{W}) > 0 \}$$

the failure probability can be defined as

$$\begin{aligned} P_f &= \int_{\mathcal{F}} dP_{\mathbf{W}}(\mathbf{w}) \\ &= \int_{\mathbf{R}^q} I[g(\mathbf{Z}(t, \mathbf{W}))] dP_{\mathbf{W}}(\mathbf{w}) \\ &= E_{\mathbf{w}}[I[g(\mathbf{Z})]] \end{aligned} \quad (3)$$

where  $I[\cdot]$  is an indicator function which is equal to 1 if the process has outcrossed to the failure domain and else is zero. The probability *measure*  $P_{\mathbf{w}}(B)$  relates a probability to any sub-domain  $B \in \mathbf{R}^q$ , i.e. a differential volume around a sample point  $\mathbf{w}$ , and can be written as  $dP(\mathbf{W}) = f_{\mathbf{w}}(\mathbf{w})d\mathbf{w}$ .  $E_{\mathbf{w}}$  signifies the expectation operator under the probability measure  $f_{\mathbf{w}}(\mathbf{w})$ .

Based on (3) SMC estimates the failure probability of the system by (4); where  $N_{sim}$  is the number of Monte Carlo samples.

$$\hat{P}_f = \frac{1}{N_{sim}} \sum_{j=1}^{N_{sim}} I[g(\mathbf{Z}^{(j)})] \quad (4)$$

### 3.2 The Girsanov Transformation

The idea of the IS based on the Girsanov theorem is to introduce a square integrable drift  $\mathbf{u}(t)$ , i.e.

$$\sum_j^p \int_0^T \mathbf{u}_j^2(\tau) d\tau < \infty$$

into the excitation, which brings the systems response to the failure region at the desired time.

$$d\tilde{\mathbf{W}}(t) = \mathbf{u}(t)dt + d\mathbf{W}(t) \quad (5)$$

The Ito SDE (1) can then be written as

$$\left. \begin{aligned} d\mathbf{Z}(t) &= \boldsymbol{\mu}(t, \mathbf{Z})dt - \boldsymbol{\sigma}(t, \mathbf{Z})\mathbf{u}(t)dt \\ &\quad + \boldsymbol{\sigma}(t, \mathbf{Z})d\tilde{\mathbf{W}}(t) \\ \mathbf{Z}(s) &= \mathbf{z} \end{aligned} \right\} \quad (6)$$

The Girsanov theorem then states that the process  $\tilde{\mathbf{W}}$  is a Wiener process under the probability measure  $P_{\tilde{\mathbf{w}}}$ . Therefore generating samples of  $\tilde{\mathbf{W}}$  under the probability measure  $P_{\tilde{\mathbf{w}}}$  corresponds to generating samples of  $\mathbf{W}$  under the probability measure  $P_{\mathbf{w}}$ . This means that the drift of the excitation might be designed in any sense that brings the system to the failure at the desired time instance. Next, the probability measure should be changed properly to take into account the effect of this transformation which is done in the following way

$$\left. \begin{aligned}
P_f &= \int_{\mathbf{R}^q} I[g(\mathbf{Z}(t, \mathbf{W}))] \frac{f_{\mathbf{W}}(\mathbf{w})}{f_{\tilde{\mathbf{W}}}(\mathbf{w})} f_{\tilde{\mathbf{W}}}(\mathbf{w}) d\mathbf{w} \\
&= \int_{\mathbf{R}^q} I[g(\mathbf{Z}(t, \mathbf{W}))] \frac{dP_{\mathbf{W}}(\mathbf{w})}{dP_{\tilde{\mathbf{W}}}(\mathbf{w})} f_{\tilde{\mathbf{W}}}(\mathbf{w}) d\mathbf{w} \\
&= E_{\tilde{\mathbf{W}}} \left[ I[g(\mathbf{Z})] \frac{dP_{\mathbf{W}}(\mathbf{w})}{dP_{\tilde{\mathbf{W}}}(\mathbf{w})} \right]
\end{aligned} \right\} (7)$$

where  $g(\mathbf{Z}) = g(\mathbf{Z}(t, \mathbf{W}))$  and the ratio  $dP_{\mathbf{W}}(\mathbf{w}) / dP_{\tilde{\mathbf{W}}}(\mathbf{w})$  is the well-known Radon-Nikodym derivative of the probability measure  $dP_{\mathbf{W}}(\mathbf{w})$  with respect to the measure  $dP_{\tilde{\mathbf{W}}}(\mathbf{w})$ .  $E_{\tilde{\mathbf{W}}}$  signifies the expectation operator under the probability measure  $f_{\tilde{\mathbf{W}}}(\mathbf{w})$ . Upon the Girsanov theorem the probability measure of (7) can be changed to  $f_{\tilde{\mathbf{W}}}(\mathbf{w})$  hence (8)

$$P_f = E_{\tilde{\mathbf{W}}} \left[ I[g(\tilde{\mathbf{X}})] \frac{dP_{\mathbf{W}}(\tilde{\mathbf{w}})}{dP_{\tilde{\mathbf{W}}}(\tilde{\mathbf{w}})} \right] \quad (8)$$

where

$$g(\tilde{\mathbf{Z}}) = g(\mathbf{Z}(t, \tilde{\mathbf{W}}))$$

The significance of equation (7) is that the probability measure can be changed so that the process  $\tilde{\mathbf{W}}$  can be used instead of the original process  $\mathbf{W}$  to estimate the failure probability of a system provided that the Radon-Nikodym derivative is taken into account. Based on (7), the failure probability of the system can be estimated using (9):

$$\hat{P}_f = \frac{1}{N_{sim}} \sum_{j=1}^{N_{sim}} I[g(\tilde{\mathbf{Z}}^{(j)})] \left( \frac{dP_{\mathbf{W}}(\tilde{\mathbf{w}}^{(j)})}{dP_{\tilde{\mathbf{W}}}(\tilde{\mathbf{w}}^{(j)})} \right) \quad (9)$$

#### 4. RUSSIAN ROULETTE & SPLITTING WITH DISTANCE CONTROL

The method encompassed two components “Russian Roulette and Splitting” (RRS), which replaces “unimportant” realizations with the “important” ones, and “Distance Control” (DC), which takes care of determining the importance of the realizations. The method substitutes the processes with low probability of causing failure, called the unimportant processes, by the so-called important processes i.e. processes with higher probability of failure. This substitution might be readily done by splitting (duplicating) some of the important processes with control over their statistical weights such that the statistics of the simulation is not changed after splitting. The distance measure is used to distribute the samples in the state space. Pradlwarter and Schueller (Pradlwarter, Schueller, & Melnik-Melnikov 1994) define this in the following way. A given realization  $\mathbf{z}(t)$  of the  $p$ -dimensional state vector  $\mathbf{Z}(t)$  is associated with a vector  $\mathbf{I}(\mathbf{z}(t))$  with non-dimensional components  $l_i(\mathbf{z}(t))$ .

$$l_i(\mathbf{z}(t)) = \frac{z_i(t) - \mu_{Z_i}(t)}{\sigma_{Z_i}(t)}, \quad i = 1, \dots, p \quad (10)$$

where  $\mu_{z_i}(t)$  and  $\sigma_{z_i}(t)$  denotes the mean value and the standard deviation of the possible non-stationary process  $\mathbf{Z}(t)$ . In case these cannot be determined analytically a preliminary SMC is performed. The components  $l_i(\mathbf{z}(t))$  may otherwise be specified with arbitrarily selected relative weight. The distance measure  $d(\mathbf{z}(t))$  related to the realization is then defined as

$$d(\mathbf{z}_j(t)) = \left. \begin{aligned} & \sum_{k=1}^K a_j \|\mathbf{l}(\mathbf{z}_{j_k|j}(t)) - \mathbf{l}(\mathbf{z}_j(t))\| \\ & a_1 > a_2 > \dots > a_K \end{aligned} \right\} \quad (11)$$

where  $\mathbf{z}_{j_k|j}(t)$  denote the  $k^{\text{th}}$  closest realization to  $\mathbf{z}_j(t)$  and  $\|\cdot\|$  is the Euclidian norm. The closest realization with the weight  $a_i$  is weighted highest. The weights were chosen as

$$a_j = 2^{1-j} \quad (12)$$

For a SDOF oscillator subjected to Gaussian white noise  $\|\mathbf{l}(\mathbf{z})\|$  with  $\mathbf{l}(\mathbf{z}(t))$  defined by (10) is proportional to the mechanical energy of the oscillator. However, (10) does not represent the mechanical energy in any other case than the indicated. Instead, (11) can be replaced with

$$d(\mathbf{z}_j(t)) = \sum_{j=1}^K a_j E_m(\mathbf{z}_{j_k|j}(t) - \mathbf{z}_j(t)) \quad (13)$$

where  $E_m$  is the mechanical energy of the system. The mechanical energy, itself could alternatively be used as a distance measure. This possibility is also examined by the authors though no improvement of the results compared to the weighting proposed by (11) is observed; which has already been reported in the literature (Pradlwarter, Schuëller, & Melnik-Melnikov 1994, Pradlwarter & Schuëller 1997).

## 5. SUBSET SIMULATION

The subset simulation strategy starts from the reachable barrier level(s) by a predefined low number of samples and increase the level gradually until the highest barrier level required. This can be done by defining intermediate probability

$$p_f = p_f^{(m)} \triangleleft p_f^{(m-1)} \triangleleft \dots \triangleleft p_f^1$$

$f$  corresponding to the intermediate barrier levels  $b = b_m > b_{m-1} > \dots > b_1$ . Using this property taken from the fact that failure probability can not increase as the barrier level increases, the required failure probability  $p_f$  is written as

$$p_f(b_2|b_1) = \frac{p_f(b_2 \cap b_1)}{p_f(b_1)} = \frac{p_f(b_2)}{p_f(b_1)} \quad (14)$$

Using (14) the final failure probability, i.e. the lowest failure probability required, is written as the following product

$$p_f(b) = p_f(b_1) \prod_{i=1}^{m-1} p_f(b_{i+1}|b_i) \quad (15)$$

The method then follows with estimation of each of the  $m$  terms on the right hand side of (15) using some type of Monte Carlo simulation. Therefore it is beneficial to let the barrier level be chosen in an adaptive manner and fix the intermediate failure probabilities associated to them. All of the terms in the product are chosen large enough so that they can be estimated with low number of samples, i.e.  $p_0 = 0.1$  in conjunction with (16).

$$\left. \begin{aligned} p_f(b_1) &= p_0 \\ p_f(b_{i+1}|b_i) &= p_0, \quad i = 1, \dots, m-1 \end{aligned} \right\} (16)$$

$p_f(b_1)$  can then be estimated efficiently by SMC with low number of samples i.e.  $N_{sim} = 100$ . However the conditional probability terms in (14) can not be estimated by SMC and need a technique which is capable of generating samples conditioned on the previous samples. Au and Beck (Au & Beck 2001) proposed using a Modified Metropolis-Hastings (MMH) algorithm for this purpose and called it the *subset simulation*.

The method starts with a SMC with  $N_{sim}$  number of samples which allows accurate estimation for the first term on the right hand side of (15). The realizations of the excitations in the  $i^{th}$  level of the simulation, i.e.  $\dot{\mathbf{W}}^{(i)} = \{\dot{\mathbf{w}}_1^{(i)}, \dots, \dot{\mathbf{w}}_{N_{sim}}^{(i)}\}$  where  $\dot{\mathbf{W}}^{(i)}$  denotes increments of the Wiener process, which their response corresponds to the barrier levels higher than the barrier level  $b_1$ . These realizations provide a set of the so-called seeds for generating the next generation of excitations. Candidates for next generation of excitations are generated using a conditional sampler, e.g. MMH, using these seeds. This step provides the estimation for the conditional terms in (15) and will be repeated  $m$  times, c.f. (15), to reach the required failure probability i.e.  $p_0^m$  provided (16).

$$p_f^i = \frac{p_f^{i-1}}{N_{sim}} \sum_{j=1}^{N_{sim}} I_{\mathcal{F}^{(i)}}(\dot{\mathbf{w}}_j^{(i)}) \quad , \quad i = 1, \dots, m \quad (17)$$

where  $p_f^0 = 1$ ;  $p_f^i$  represents the minimum failure probability calculated in the  $i^{th}$  step of the simulation.  $F$  denotes the failure domain and  $I_{F^{(i)}}(\dot{\mathbf{w}}_j^{(i)})$  is the indicator function which will be one if the response to  $\dot{\mathbf{w}}_j^{(i)}$  lies in the  $i^{th}$  intermediate failure domain and is zero otherwise.

## 6. ASYMPTOTIC SAMPLING

The method is developed based on the asymptotic estimation of multi-normal integrals. The problem of approximating a multi-normal probability integral (18) on the scaled LSF which can be represented after proper transformation of random variables as

$$p(\beta; \xi) = \int_{g(\beta^{-1}\xi) < 0} \prod_{i=1}^N \varphi\left(-\frac{1}{2}\xi_i^2\right) d\xi \quad (18)$$



where  $\xi = \{\xi_1, \dots, \xi_N\}$  denotes the vector of standardized independent multi-normal random variables; LSF is defined as  $g(\beta^{-1}\xi) < 0$ . The first parameter in the parentheses on the left hand side denotes scaling of the variables in the LSF.  $\varphi(\cdot)$  denotes the standard normal density function. The boundaries of the integral in (18) can be changed to unscaled LSF which reads

$$p(\beta; \xi) = \beta^N \int_{g(\xi) < 0} \prod_{i=1}^N \varphi\left(-\frac{\beta^2}{2}\xi_i^2\right) d\xi \quad (19)$$

which is shown to be asymptotically equal to  $\Phi(-\beta J^{1/2})$  as  $\beta \rightarrow \infty$ ; where  $J^{1/2}$  is a parameter related to the first and second order derivatives of the LSF at the design point. (18) and (19) mean that the desired low probabilities can be approximated on a scaled failure domain and then transformed back into the unscaled domain. This idea forms the procedure of AS (Bucher 2009) which starts with a SMC on the scaled variables i.e. excitations with *artificially* increased standard deviation. The reliability index is primarily estimated based on the scaled failure probability, e.g.  $\beta(f) = \Phi(1 - \rho^{\text{scaled}})$ , and is then scaled back to the unscaled space, e.g.  $\beta(1) = f^{-1} \beta(f)$ . The desired probability is estimated as  $\Phi^{-1} \beta(1)$  then.

More details of the method and some practical aspects for improving its efficiency on dynamic problems are presented in (Sichani, Nielsen, & Bucher a, Sichani, Nielsen, & Bucher b).

## 7. NUMERICAL SIMULATION

### 7.1 SDOF oscillator

The first simulation is based on a single DOF linear oscillator (20), characterized by  $\omega_n = 1\text{s}^{-1}$  and  $\zeta_n = 0.01$

$$\ddot{x}(t) + 2\zeta_n\omega_n\dot{x}(t) + \omega_n^2x(t) = w(t) \quad (20)$$

$w(t)$  is zero-mean Gaussian white noise with unit intensity. The barrier level is normalized with respect to the standard deviation of the response  $\sigma_x = (4\zeta\omega^3)^{-1/2}$ .

$$b_N = \frac{b}{\sigma_x} \quad (21)$$

The failure event is defined as the maximum of the absolute value of the response of the oscillator exceeds a certain threshold “ $b$ ”, i.e.  $\Pr(|y(t)| > b)$  for  $t \in [0, 600]$ . The normalized barrier level is assumed to be  $b_N = 5$  in simulations. Simulations are carried out with  $\Delta t = 0.0614\text{s}$  and  $t \in [0, 600]\text{s}$  which involves 9772 samples to examine the performance of the method in high dimensions. Exact failure probability and reliability index for the problem, calculated with standard Monte Carlo simulation with  $2 \times 10^6$  samples, are  $P_f(600) = 2.07 \times 10^{-4}$  and  $\beta = 3.5310$  respectively.

### 7.1.1 Importance sampling

Figure 1.a shows one of the control functions of the SDOF oscillator. The response of the system to this excitation, i.e. deterministic drift, is shown in 1.b. Estimation of the failure probability for different time instances are shown in figure 2. As seen from this figure IS is very attractive in the first sight due to its high accuracy for failure levels. However its shortcomings in application to more complicated problems are also

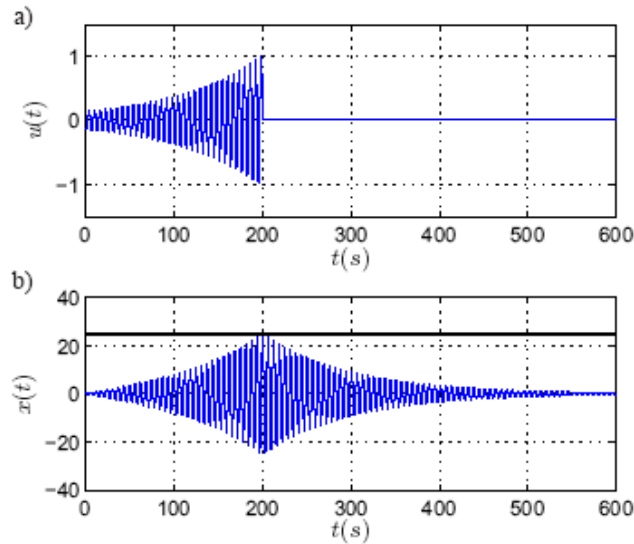

Figure 1: Control function and response of the SDOF oscillator; a) Control function, b) response.

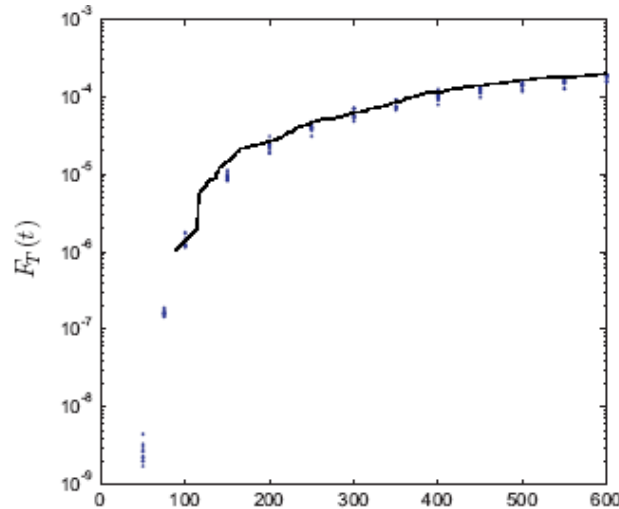

Figure 2: Estimations of the failure probability with IS; Solid line: SMC, dots : IS

considerable. Since failure may occur at any time instance within a distinguished time period  $t \in [0, T]$ s, IS requires that all of the control functions that cause failure during this time interval should be available to allow considering the interaction between different design point control functions. This requires heavy dynamic analysis in order to compute these control functions primarily and also high memory is required to save them. Unfortunately this requirement specifically for Multi Degree Of Freedom (MDOF) nonlinear systems poses severe difficulties as in such cases there exist no analytical solution for the design point excitations. In such cases a high dimensional

optimization algorithm should be used to find the design points excitations, alternatively called control functions, which is very expensive, (Koo, Der Kiureghian, & Fujimura 2005).

These problems have also been noticed by other researchers, however to the best knowledge of authors IS applications are very limited i.e. nonlinear SDOF systems, (Naess & Gaidai 2008), or linear MDOF systems with only one stochastic excitation process (Jensen & Valdebenito 2007). The above reasons conclude that using IS with presented scheme may not be considered a proper candidate for application to wind turbine models.

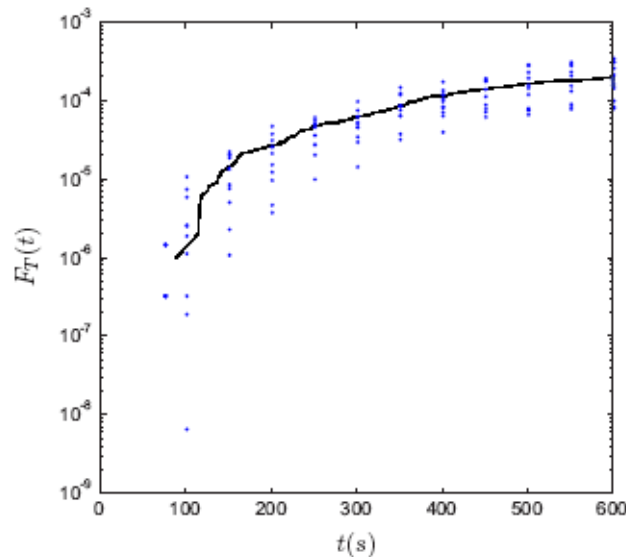

Figure 3: Estimations of the failure probability with DCMC; Solid line: SMC, dots: DCMC

### 7.1.2 Russian roulette & splitting with distance control

The DCMC with the distance measure considered as a weighted summation of six closest neighbor processes i.e.  $K = 6$ . The parameters of the DCMC are chosen  $\beta = 0.8$ ,  $p_0 = 0.5$ ,  $\omega_{min} = 5 \times 10^{-5}$ , (Pradlwarter & Schueller 1999), and the results are shown in the figure 3. A unique feature of DCMC compared to the other algorithms implemented in this study is that it works directly on the responses and does not make any changes in the excitations. Advantages of DCMC are generality of application and low memory requirements and its capability in handling high dimensional problems.

The method's shortcomings are the implementation of it which requires all of the samples to run in parallel i.e. all 500 simulations should evolve simultaneously to allow statistical weighting adjustment. This requires changing the states during the time integration of the governing equations. This may cause some practical issues during implementation of the algorithm on practical codes. Next, DCMC like IS is capable of estimating failure probability of a predefined threshold level. This is less motivating in wind turbine problems where the opposite is required i.e. the threshold for a given failure probability.

### 7.1.3 Asymptotic sampling

For each barrier level  $N_{sim} = 500$  number of samples with 5 support points are used with different  $\Delta f$  and range of  $f$ . Figure 4 illustrates the effect of distribution of support points. Clearly too low values for  $f$  will cause all of the processes to cross out which does not give any information while choosing too large  $f$  will cause few out crossings which increases the uncertainty of the estimation. It is seen that the maximum accuracy of the method, i.e. the least standard deviation of the estimate, is achieved when the support points are distributed in the region where 2 to 98 percent of the realizations crosses out c.f. figure 4.b compared to figure 4.a in which 2 to 50 percent of the realizations have crossed out. The black dots on the right hand side of the figures show the exact value of the beta.

Figure 5 shows estimations of the failure probability for the same barrier level in different time instants where solid line shows the SMC results.

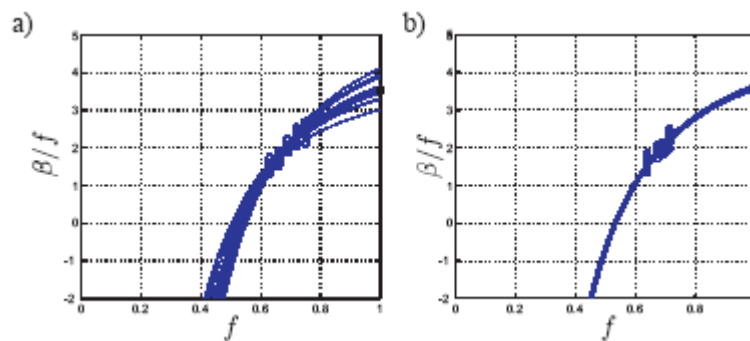

Figure 4: Estimations of the reliability index  $\beta$  with asymptotic sampling for 600[s]; single DOF oscillator. a) Uniform distributed support points,  $\text{CoV}_{\text{Pf}}(600) = 1.2$  b) Non-uniform distributed support points,  $\text{CoV}_{\text{Pf}}(600) = 0.2$

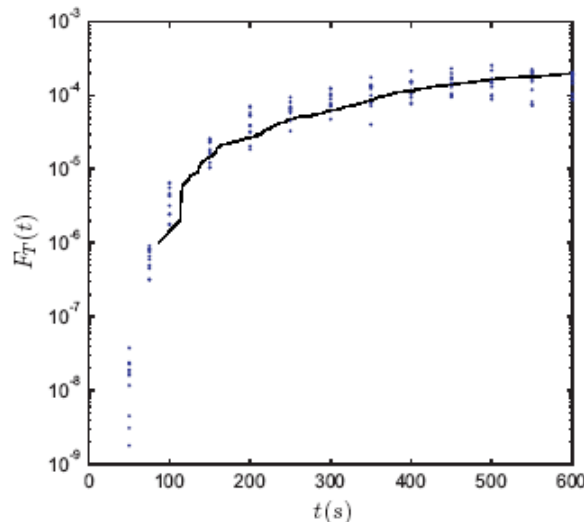

Figure 5: Estimations of the failure probability with AS; Solid line: SMC, dots: AS

### 7.1.4 Subset simulation

Results of SS applied on the oscillator for failure for different time instants within the time interval  $t \in [0, 600]$ s are shown in figure 6 as counterpart of figures 2, 5 and 3. For estimation of failure probability in this figure 4 levels of MCMC is used only for  $T =$

400s, 450s, 600s; for  $T = 150s, 200s, 250, 300, 350s$  5 MCMC levels are used and for  $T = 100s, 75s, 50s$  respectively 6,7 and 8 MCMC levels with  $p_0 = 0.1$  with  $N_{sim} = 500$  samples in each step. The proposal distribution is assumed uniform with half spread equal to the standard deviation of the excitation seeds (Au, Cao, & Wang 2010).

The SS approach is based on changing the excitation realizations like IS and AS. The method is based on designing new excitations within a fixed time duration based on previous excitation realizations which have reached the highest barrier levels in previous simulations e.g. seeds. In this way it may be interpreted as a stochastic optimization procedure.

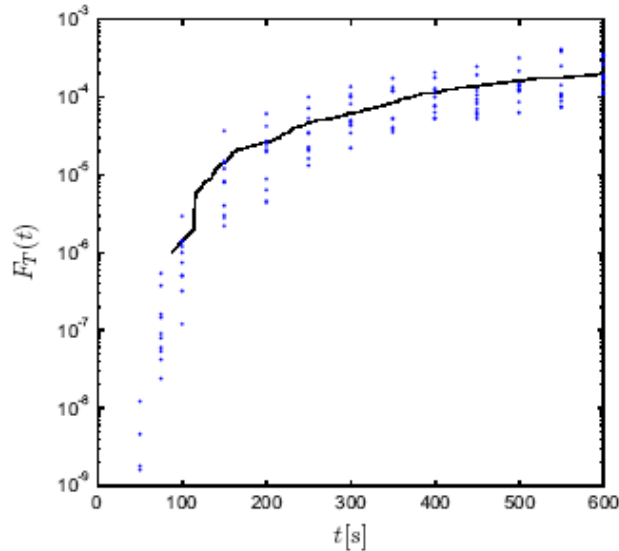

Figure 6: Estimations of the failure probability with SS; Solid line: SMC, dots: SS

The method has several interesting features which are in line with requirements of the wind turbine design criteria. An advantage of SS is that it estimates the thresholds related to a given failure probability. This is what is required in wind turbine design codes, (IEC 2005), while the other three methods provide the failure probability given for a predefined threshold level.

SS is a very accurate method for low failure probability estimation of high dimensional nonlinear systems (Au, Ching, & Beck 2007). However some practical procedures should be taken into account for very high number of basic variables which should be kept in memory during simulations e.g. random numbers required to generate the turbulent wind field. Nevertheless the method seems to propose a good candidate for application on the wind turbine model. Most favorably the method is a so-called acts as a black-box which means it does not require any a-priori knowledge of system which adds to its advantages.

## 7.2 Wind turbine

Design codes for wind turbines are based on a return period (expected first-passage time) of  $T_r = 50\text{year}$ , which itself requires design values related to the failure probability of the wind turbine models down to the order  $10^{-7}$ . According to the IEC61400-1 standard (IEC 2005), the design value  $r$  of a stochastic response  $\{R(t), t \in [0, \infty[ \}$  (deformation, bending moment, stress, etc.) is obtained by extrapolation of the failure probability under normal operation of the design value  $r$  in a referential epoche  $T$  to  $T_r$ . Presuming independent failure events in adjacent referential epoche the exceedance probability of the design value is given as

$$P(R_{max}(T_r) > r) \simeq \frac{T_r}{T} P(R_{max}(T) > r) \quad (22)$$

$R_{max}(T)$  and  $R_{max}(T_r)$  denote the maxima value in intervals  $T$  and  $T_r$ . With  $T_r = 50$  year and  $T = 600s$ , (22) provides the relation

$$P(R_{max}(T) > r) \lesssim \frac{T}{T_r} = 3.8 \times 10^{-7} \quad (23)$$

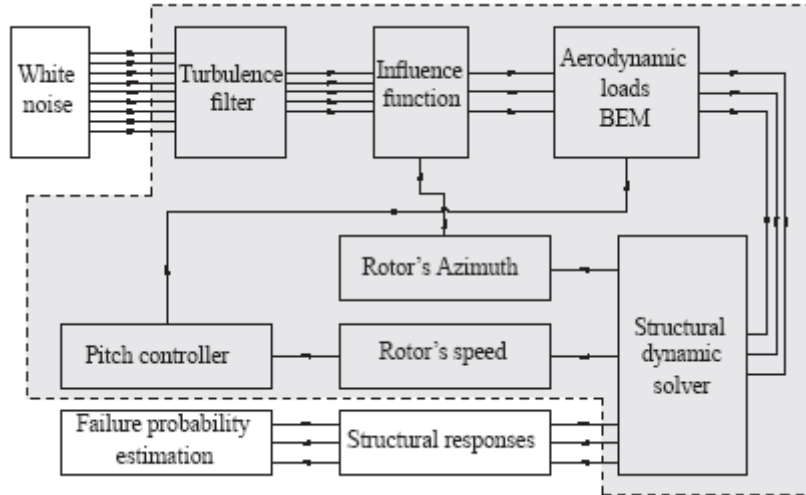

Figure 7: Flowchart of the wind turbine model.

The design value  $r$  is obtained as the solution of (23). It is out of question to determine this by SMC simulation due to the indicated low failure probability. The Suggested approach in the IEC61400-1 standard is to use a Weibull or a Gumbel distribution as the distribution function  $F_{R_{max}}(T) = 1 - P(R_{max}(T) > r)$ . The locations, scale and shape parameter, are estimated from the available sample.

Applicability of the selected method on a reduced order model of a 5MW reference wind turbine developed in previous study c.f. figure 7, (Sichani, Nielsen, & Bucher b), is tested. Specifications of the wind turbine model are adopted from the NREL reference wind turbine (Jonkman, Butterfield, Musial, & Scott 2009). It is attempted to cover the principal behavior of a wind turbine.

The model consists of structural and aerodynamic loads but no controller, i.e. fixed rotational speed is assumed. The details of the model specifications are explained in (Sichani, Nielsen, & Bucher b). The wind field is simulated in 31 nodes on 50m distance from nacelle of the rotor with 63m blades using a state space model. Failure probabilities of the model are estimated with the AS as the primary candidate method. Figure 8 shows failure probability of the wind turbine model estimated with SMC with  $4 \times 10^5$  samples, AS with  $32 \times 500$  samples (Sichani, Nielsen, & Bucher b), Weibull and Gumbel fits with 500 simulations each.

The results of AS estimations show good consistency with the SMC results. The AS method has the advantages of very low memory requirement and simplicity of application even for very high dimensional problems.

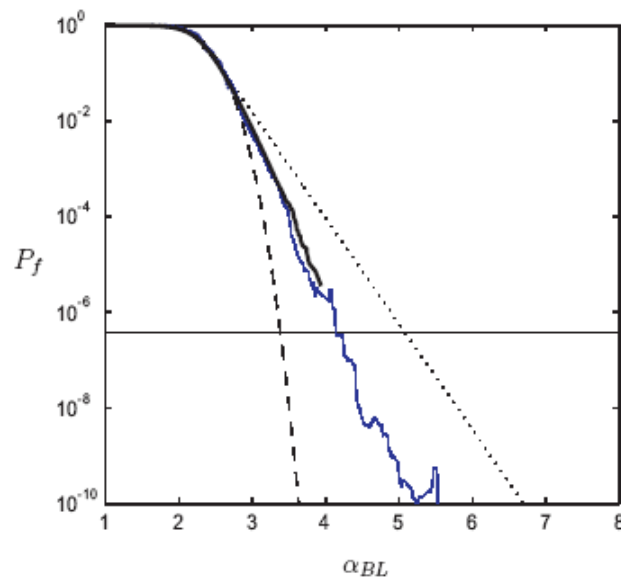

Figure 8: Estimated failure probability of the wind turbine for fixed speed wind turbine. —: 50 year recurrence period, bold black: SMC, ---: 3-parameter Weibull distribution, ···: Gumbel distribution, blue: AS.

## 8. CONCLUSIONS

Among the methods considered in this paper IS shows the highest accuracy however faces serious difficulties in application on wind turbine models due to excessively high number of dynamic analysis it requires for nonlinear systems. The DCMC method is applicable on such models however certain features, i.e. parallel running and communication of samples during solution, are required which may limit its applications on practical codes. The AS and SS methods seem the most suitable methods since they have similar characteristics regarding no a-priori knowledge about model as well as low memory requirements. The AS method is already applied on a wind turbine model and results show good agreement with the SMC with much higher efficiency.

It worth mentioning that total number of dynamic analysis required by all of the methods mentioned in the paper for accurate results may be considerably larger than the nominal number of samples, e.g. 500 in this paper, except the DCMC method.

## REFERENCES

- Au, S., Z. Cao, & Y. Wang (2010). Implementing advanced monte carlo simulation under spreadsheet environment. *Structural Safety* 32(5), 281 – 292. Probabilistic Methods for Modeling, Simulation and Optimization of Engineering Structures under Uncertainty in honor of Jim Beck's 60th Birthday.
- Au, S., J. Ching, & J. Beck (2007). Application of subset simulation methods to reliability benchmark problems. *Structural Safety* 29(3), 183 – 193. A Benchmark Study on Reliability in High Dimensions.
- Au, S. K. & J. L. Beck (2001). First excursion probabilities for linear systems by very efficient importance sampling. *Probabilistic Engineering Mechanics* 16, 193–207.

- Breitung, K. (1989). Asymptotic approximations for probability integrals. *Probabilistic Engineering Mechanics* 4(4), 187–190.
- Bucher, C. (2000). *An importance sampling technique for randomly excited systems discretized by finite elements*. Volume II. In: Ko J.M., Xu Y.L., editors, *Advances in structural dynamics*. Amsterdam: Elsevier.
- Bucher, C. (2009). Asymptotic sampling for highdimensional reliability analysis. *Probabilistic Engineering Mechanics* 24, 504–510.
- Caires, S. & A. Sterl (2005). 100-year return value estimates for ocean wind speed and significant wave height from the era-40 data. *Journal of Climate* 18(7), 1032–1048.
- Chen, J. & J. Li (2009). A note on the principle of preservation of probability and probability density evolution equation. *Probabilistic Engineering Mechanics* 24, 51–59.
- IEC (2005). Wind turbines – part 1: Design requirements. IEC International Standard 61400-1.
- Jensen, H. & M. Valdebenito (2007). Reliability analysis of linear dynamical systems using approximate representations of performance functions. *Structural Safety* 29, 222–237.
- Jonkman, J., S. Butterfield, W. Musial, & G. Scott (2009). Definition of a 5-mw reference wind turbine for offshore system development. *National Renewable Energy Laboratory* 20, 136–147.
- Koo, H., A. Der Kiureghian, & K. Fujimura (2005). Design-point excitation for non-linear random vibrations. *Probabilistic Engineering Mechanics* 20, 136–147.
- Li, J. & J. Chen (2009). *Stochastic Dynamics of Structures*. Wiley.
- Mackay, E., P. Challenor, & A. Baha (2010). On the use of discrete seasonal and directional models for the estimation of extreme wave conditions. *Ocean Engineering* 37, 425–442.
- Macke, M. & C. Bucher (2003). Importance sampling for randomly excited dynamical systems. *Journal of Sound and Vibration* 268, 269–290.
- Naess, A. & P. Clausen (2001). Combination of the peakover-threshold and bootstrapping methods for extreme value prediction. *Structural Safety* 23, 315–330.
- Naess, A. & O. Gaidai (2008). Monte carlo methods for estimating the extreme response of dynamical systems. *Journal of Engineering Mechanics* 134(8), 628–636.
- Pradlwarter, H. & G. Schuëller (1997). On advanced Monte Carlo simulation procedures in stochastic structural dynamics. *International Journal of Non-Linear Mechanics* 32(4), 753–774(10).
- Pradlwarter, H. & G. Schuëller (1999). Assessment of low probability events of dynamical systems by controlled Monte Carlo simulation. *Probabilistic Engineering Mechanics* 14, 213–227.
- Pradlwarter, H., G. Schuëller, & P. Melnik-Melnikov (1994). Reliability of mdof systems. *Probabilistic Engineering Mechanics* 9(4), 235–243.
- Sichani, M., S. Nielsen, & C. Bucher (a). Applications of asymptotic sampling on high dimensional structural dynamic problems. *submitted to Structural Safety*.
- Sichani, M., S. Nielsen, & C. Bucher (b). Efficient estimation of first passage probability of high dimensional non-linear systems. *submitted to Probabilistic Engineering Mechanics*.



