



Aalborg Universitet

AALBORG UNIVERSITY
DENMARK

Optimization of Front Axle Suspension System of Articulated Dump Truck

Langer, Thomas Heegaard; Christensen, Brian B.; Mouritsen, Ole Ø.; Hansen, Michael Rygaard

Published in:

Proceedings of the First Joint International Conference on Multibody System Dynamics: CD-ROM

Publication date:
2010

Document Version
Accepted author manuscript, peer reviewed version

[Link to publication from Aalborg University](#)

Citation for published version (APA):

Langer, T. H., Christensen, B. B., Mouritsen, O. Ø., & Hansen, M. R. (2010). Optimization of Front Axle Suspension System of Articulated Dump Truck. In *Proceedings of the First Joint International Conference on Multibody System Dynamics: CD-ROM* <http://www.imsd10.fi/>

General rights

Copyright and moral rights for the publications made accessible in the public portal are retained by the authors and/or other copyright owners and it is a condition of accessing publications that users recognise and abide by the legal requirements associated with these rights.

- Users may download and print one copy of any publication from the public portal for the purpose of private study or research.
- You may not further distribute the material or use it for any profit-making activity or commercial gain
- You may freely distribute the URL identifying the publication in the public portal -

Take down policy

If you believe that this document breaches copyright please contact us at vbn@aub.aau.dk providing details, and we will remove access to the work immediately and investigate your claim.

Optimization of Front Axle Suspension System of Articulated Dump Truck

Thomas H. Langer^{*}, Brian B. Christensen^{*}, Ole Ø. Mouritsen[#], Michael R. Hansen[†]

^{*} Research & Development Department
A/S Hydrema Produktion
Gl. Kirkevej 16, 9530 Støvring, Denmark
e-mail: tla@hydrema.com, bbc@hydrema.com

[#] Depart. of Mechanical and Manufacturing Engineering
Aalborg University
Pontoppidanstræde 101, 9220 Aalborg Ø, Denmark
e-mail: oom@me.aau.dk

[†] Department of Engineering
University of Agder
Serviceboks 509, 4898 Grimstad, Norway
e-mail: michael.r.hansen@uia.no

ABSTRACT

Manufacturers of construction machinery are challenged to accommodate legal requirements on the vibration exposure associated with their products. For such machines a crucial performance parameter is the whole body vibration level that the operator is subjected to.

This paper presents results from ongoing research collaboration between Hydrema Produktion A/S, Aalborg University and the University of Agder on comfort improvement. The main goal of the research project is to improve ride comfort of articulated construction machinery by use of multibody simulation models.

In this paper the application that has been subjected to comfort improvement is a two axle articulated dump truck. The comfort has been in terms of whole body vibration exposure and the overall improvement has been made possible by adding front axle suspension. However, a hydraulic stabilizing system between the tractor and trailer of the machine and the varying load distribution when turning the steering wheel has revealed a non-trivial task of sizing the new suspension system in an optimal way.

Hydraulic accumulators and valves are used as suspension elements. The topology of the suspension frame is given together with a work cycle used to evaluate the whole body vibrations.

By use of a multibody simulation model of the dump truck the whole body vibration exposure has been computed using the predefined work cycle as model input. The design parameters comprise the components of the hydraulic subsystem of the suspension, i.e., the size of the hydraulic accumulators and the initial gas pressure as well as the size of the damping orifices. The design criteria has been the comfort as evaluated from the typical work cycle with a number of side constraints such as availability of components, available space, collision avoidance and design rules given by the supplier of accumulators.

A non-gradient optimization routine has been applied to determine the optimal design, i.e., the design with the best possible ride comfort in terms of whole body vibrations that does not violate any of the constraints. Some variables have been treated as discrete such as the accumulator volume. In general, the results have been encouraging and may be used directly as guidelines in both current and future design.

Keywords: ride comfort, suspension, construction machinery, optimization, discrete design variables.

1 INTRODUCTION

Ride comfort has become an important competitive parameter among manufacturers of mobile machines, including construction machinery such as earth moving equipment. The reason for this is mainly legal requirements. The European directive 2002/44/EC defines some limits for the daily exposure to vibrations experienced by human operators [21]. For whole body vibration these directives pose a non-trivial challenge to accommodate with the equipment available on the market today.

The manufacturers are required to declare the vibration exposure associated with the use of the machinery. This prompts two challenges.

The first is getting information on realistic and representative duty cycles, as there is no standardized duty cycles from which the whole body vibration level should be declared. The first and only attempt to define duty cycles for construction equipment is the technical specification ISO 25398 which were approved by the European Committee for Standardization on April 18 2008 [4]. It defines for example that an articulated frame dumper undergoes 1) A loading process 2) travel with load 3) unloading and 4) travel without load. Though no information is given on travel speed, duration of the different operations or condition of the soil on which the dumper is travelling. The technical specification lists some equivalent vibration values for different kinds of construction machinery. Experiments emphasize that variation of travel speed running over obstacles is pivotal to the vibration exposure on the operator [8] [16]. Also there is big difference in the dynamic response of a small dump with a 10 tons capacity and a big dump truck used in the mining industry.

The other challenge is to evaluate and improve the ride comfort of the machinery. Improvement of ride comfort requires proper choices of the components for suspension systems. Often the design will be restricted by commercially available components. Evaluation and improvement of ride comfort is carried out most cost efficiently by model based prototyping [3] [10]. In a computer model it is possible to change parameters and evaluate the performance in a cost efficient way compared to changing and testing a full scale prototype. But the model has to be able to evaluate the ride comfort in terms of whole body vibration. The calculation scheme for this is specified in ISO 2631 [1]. Doing the evaluation by simulation models requires a three dimensional multibody simulation model with the ability to handle off-road soil conditions.



Figure 1. Hydrema 912DS Articulated Dump Truck.

In this paper a hydraulic suspension design for a 10 tonnes articulated dump truck, Figure 1, is presented and possible design variables are identified. Some design rules are introduced that effectively limits the feasible design space improving the chances of finding a proper design. Multibody dynamics simulation is applied together with a non-gradient optimization routine to find the best combination of components without violating the side constraints.

2 MODELLING

Hydrema Produktion A/S has in collaboration with Aalborg University and University of Agder developed an in-house three dimensional multibody code in Fortran 90. The program is able to simulate some of the Hydrema vehicles. The program is build up in modules and the model can easily be parameterized. For this research the multibody simulation code has been used to simulate the Hydrema 912DS Dumper, Figure 2.

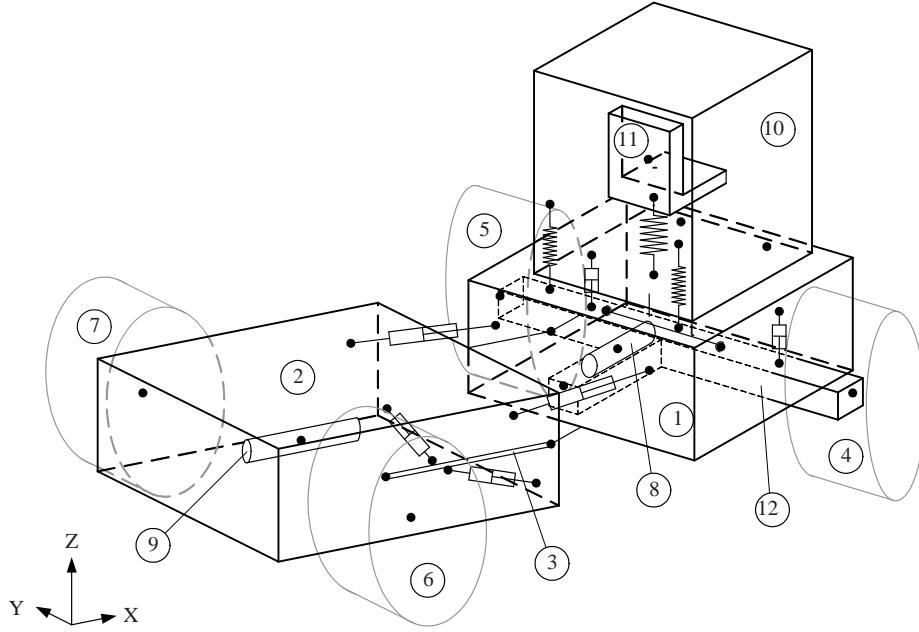

Figure 2. Hydraema 912DS Articulated Dump Truck consisting of 12 bodies.

The governing equations for the mechanical system consist of a set of second order differential equations and a set of algebraic equations. The entire set of equations is listed in Equation 1:

$$\begin{bmatrix} \underline{\mathbf{M}} & -\underline{\Phi}_{\mathbf{q}}^T \\ \underline{\Phi}_{\mathbf{q}} & \underline{\mathbf{0}} \end{bmatrix} \begin{bmatrix} \dot{\mathbf{h}} \\ \lambda \end{bmatrix} = \begin{bmatrix} \mathbf{g}^{ext} - \mathbf{b} \\ \gamma \end{bmatrix} \quad (1)$$

The governing equations for the hydraulic stabilizing system consist of a set of first order differential equations given by:

$$\dot{\mathbf{p}} = \underline{\mathbf{C}} \cdot \mathbf{h} + \pi \quad (2)$$

In Equation 1 \mathbf{g}^{ext} is a vector containing the generalized external forces acting on each body. Gravity, hydraulic cylinder forces, springs and dampers, propel torque and the tire-ground interactions all contribute to components of \mathbf{g}^{ext} . The stiffness and damping characteristics of rubber bushing and springs and dampers are described by linear and second order formulations. The wheels are modeled as individual bodies. The external force components acting on the wheels are the reaction forces between the terrain and wheels. The force contributions from the hydraulic cylinders are calculated from the pressure states in the hydraulic circuits such as stabilizing system, steering system and suspension system. The pressure gradients, $\dot{\mathbf{p}}$, are computed from Equation 2 that is based on mass conservation and assumed Newtonian fluids yielding a set of decoupled equations.

For the numerical time integration of the initial value problem a fixed step integrator is applied. The dynamics of the hydraulic system is considerably stiffer than the dynamics of the mechanics. Therefore a smaller time step is applied for integration of the hydraulic states of Equation 2. By interpolation of the states of the mechanics it is possible to integrate the hydraulic gradients by smaller steps, see also [12].

In order to be able to evaluate realistic ride comfort on off-road conditions the tire response is crucial. In the multibody simulation code a tire model developed for off-road vehicles with big tires is applied. The model needs only few modeling parameters and is able to handle short wave terrain with obstacles, see also [19].

To control the dumper in the simulation model two inputs are used. The first one is the forward/backward speed. A reference speed is given and a PI Controller adjusts the torque on the drive shaft and an opposite

torque where the engine is mounted. The other input is a path that the dumper should follow. The steering is done by opening and closing valves connected to the two steering cylinders between the articulated frames. A controller is applied to convert the offset between the dumper and the path to a valve opening signal. The controller is described in more detail in [24].

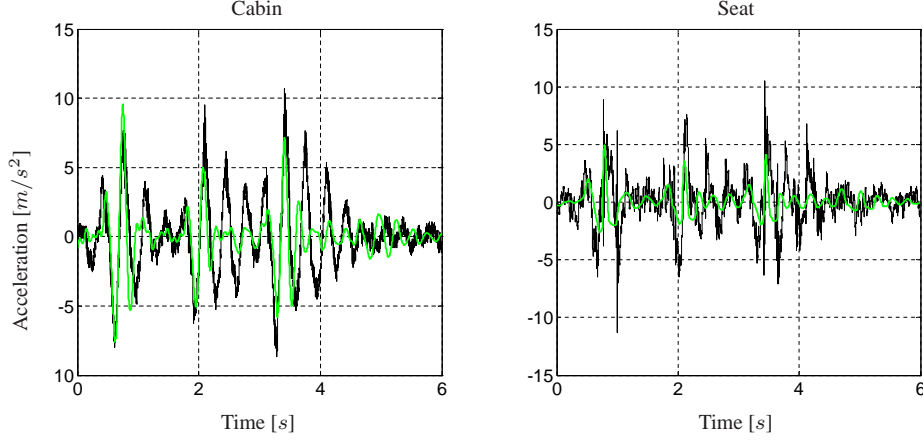

Figure 3. Comparison of vertical accelerations from the simulation (green) of the cabin and seat with the dynamic response of full scale measurement (black).

In order to evaluate the whole body vibration level in accordance with the ISO 2631 [1] digital filters are build into the model to handle the frequency weightings of the acceleration response. The digital filters are implemented as described in [23] and facilitate the calculation of the vibration exposure for each of the three directions as the RMS value of the weighted acceleration:

$$a_{w(\text{direc})} = \left[\frac{1}{T} \int_0^T a_{w(\text{direc})}^2(t) dt \right]^{\frac{1}{2}} \quad (3)$$

Now the whole body vibration level is defined as the largest of the three vibration values with a scalar weighting on the x and y direction:

$$a_{w,max} = \max \{ 1.4a_{w,x}; 1.4a_{w,y}; a_{w,z} \} \quad (4)$$

The simulation code is explained in more detail in [18]. Before any design changes was made the dynamic response of the exiting dumper has been compared to measurement, Figure 3, for a specific test track. The simulated response of the cabin and seat is in reasonable accordance with the reality. The vertical frequency weighted root-mean-square acceleration a_{wz} for the simulation model is 0.86. The measured a_{wz} is 1.11. By experience the measured value will always be higher than the simulated because of the contribution of vibration from engine, gearbox, etc. Though there is a difference between simulation and measurements it is concluded that the model is well suited for evaluating the performance since the frequency response fits quite well which is considered crucial when evaluating whole body vibrations.

3 CONSIDERED SYSTEM

As the Hydrema 912DS has stiff axles the topology shown in Figure 4 has been chosen as front axle suspension. The front axle is mounted at the tractor behind the axle in a spherical joint. The sideways forces are primarily transmitted through a Panhard tension/compression bar. The vertical forces are transmitted via the two suspension cylinders as seen in Figure 4.

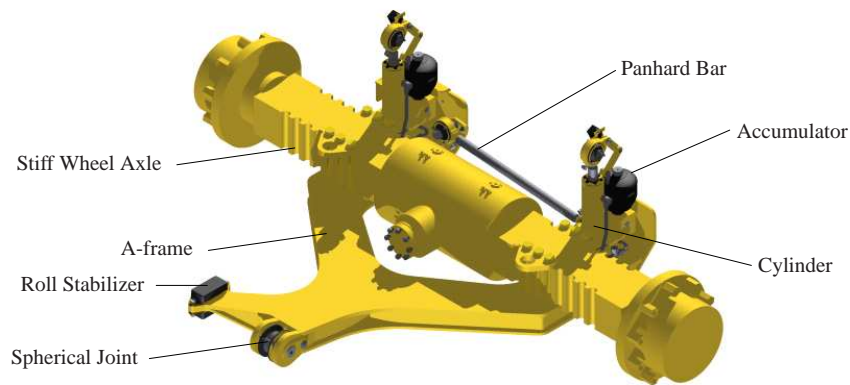

Figure 4. Front axle suspension design.

On Figure 5 a simplified diagram is shown of one hydraulic suspension circuit. The ring side of the cylinder is connected to tank pressure with a thick hose and big fittings to minimize flow induced pressure losses. The bottom side of the cylinder contains the oil pressure which carries the load from the dumper. This chamber is connected to a hydraulic accumulator through a direction valve parallel with an orifice.

Work of principal is that when the front wheel of the dumper hits an obstacle the oil from the bottom chamber should easily be displaced to the accumulator. The accumulator will afterwards try to displace the oil back in the cylinder chamber when the pressure in the cylinder decreases again. On its way back it has to pass through the orifice.

Hereby the accumulator represents a hydro-pneumatic spring of a suspension system and the orifice represents damping. These represent the main components in the suspension circuit. Besides a very slow level adjustment system is connected to the suspension circuit. It can supply or displace oil from the system. Because the supply system is throttled down it has no influence of the dynamics and is not modeled. The supply pressure is kept constant at 125 bar.

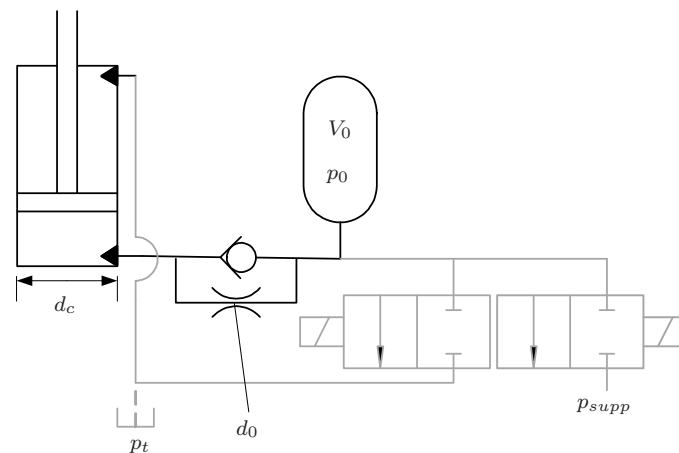

Figure 5. Characteristics of direction valve and orifice.

The direction valve is modeled as fully open/fully closed depending on the pressure difference between oil in the cylinder and the oil in the accumulator. The orifice is described by the orifice equation assuming turbulent flow. The accumulator is described by [22]:

$$constant = p \cdot V^n \quad (5)$$

p is the pressure, V is the volume of the gas and n is the polytrophic exponent which can vary from 1 to 1.67 [11].

To find the operational contraction value C_d of the orifice the pressure difference between cylinder and accumulator has been plotted as a function of the cylinder speed. Aware that the oil is compressible it still gives a reasonable indication of the response as seen in Figure 6. The blue dots are measurements. A model

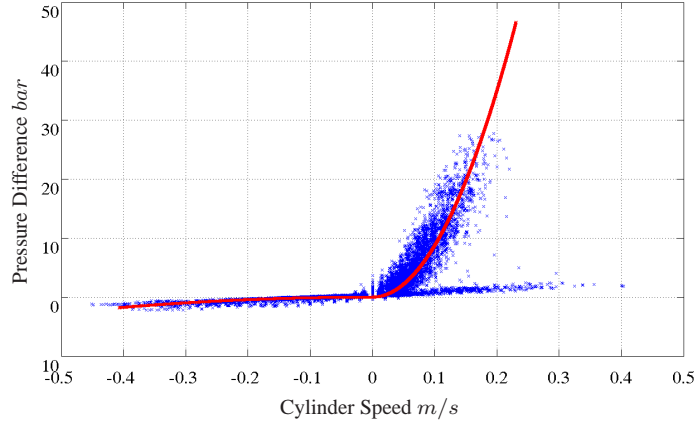

Figure 6. Characteristics of direction valve and orifice.

of the direction valve and the orifice was made in MATLAB with the cylinder travel as input. The contraction value C_d is adjusted to an operational value of 1 which gives the characteristics shown by the red curve in Figure 6. The plot on Figure 6 also indicates that the direction valve and the orifice can be modeled as turbulent flow.

The space on the considered machine is very limited. Therefore the topology design changes are very limited. The stroke of the cylinders is given by the design engineer to 80mm . Because of the limitation on the space, there are the following design variables left: Volume of the accumulator V_0 , initial pressure of the accumulator p_0 , the diameter of the cylinder d_c , the diameter of the return orifice d_o and the stiffness of the roll stabilizer rubber block called k and some clearance c_r before the roll stabilizer acts.

Observing the 6 design variables reveals that they may be divided into two categories:

1. Discrete: $\underline{y}^d = \{d_c \ V_0\}$
2. Continuous: $\underline{y}^c = \{p_0 \ d_o \ k \ c_r\}$

Hydraulic cylinders are produced by Hydrema in standard dimensions. Some possible cylinders are listed in Table 3 in Appendix I. From the supplier a number of nitrogen accumulators are extracted in a range of feasible sizes, Table 4 in Appendix I. Each accumulator are subjected to some properties in terms of the permitted operating pressure p_{per} it can stand and a permitted pressure ratio PPR which is the maximum between the duty pressure and the initial pressure of the accumulator p_0 .

4 IMPROVEMENT OF DESIGN

An optimization problem is in general formulated as the minimization of an objective function O subjected to n inequality constraints and m equality constraints:

$$\min O(\underline{y}) \quad (6)$$

$$g_i(\underline{y}) < 0.0 \quad i = 1 \dots n \quad (7)$$

$$h_i(\underline{y}) = 0.0 \quad i = 1 \dots m \quad (8)$$

where, $\underline{y} = \begin{bmatrix} \underline{y}^{(d)} \\ \underline{y}^{(e)} \end{bmatrix}$, is the vector of design variables. The objective function and the inequality constraints may be combined to form an augmented penalty function Θ that can be subjected to minimization:

$$\min \Theta(\underline{y}) = O(\underline{y}) + \sum_{i=1}^n G_i(\underline{y}) \quad (9)$$

$$G_i(\underline{y}) = \begin{cases} 0 & g_i(\underline{y}) \geq 0 \\ g_i^2(\underline{y}) & g_i(\underline{y}) < 0 \end{cases} \quad (10)$$

In this case the objective function is the ride comfort in terms of whole-body vibration exposure from Equation 4. As mentioned an articulated dump truck operates according to ISO 25398 within four modes: Loading process, travel with load, unloading, travel without load [4]. Experiences shows that the critical operation mode for a dump truck regarding ride comfort is travel [5] [8] [20].

For agricultural tractors a standardized test track, ISO 5008, is used to evaluate the ride comfort [2]. To evaluate the ride comfort of the Hydrema dump truck the 100m smooth track specified in ISO 5008 is applied, Figure 7(a). ISO 5008 prescribes three different speeds. Here the 14km/h speed is applied for an empty dump truck and 10km/h for a fully loaded dump truck.

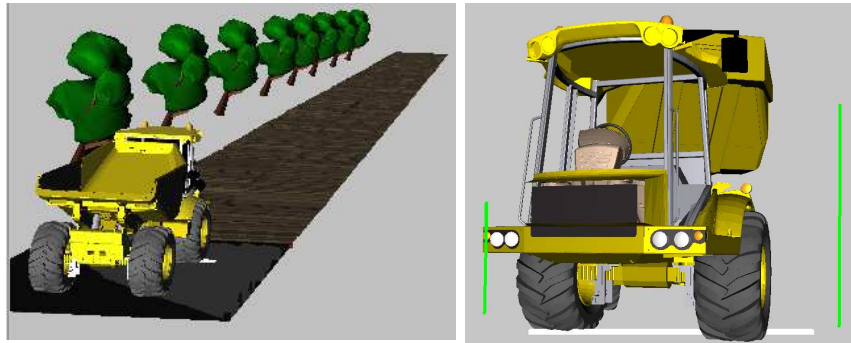

(a) ISO 5008 smooth track.

(b) Load distribution at the front wheels when fully steered out.

Figure 7.

An articulated vehicle is to a high degree characterized by the displacement of the center of gravity when the vehicle is steered out. This results in an unsymmetrical load distribution on the wheels, Figure 7(b), and some stability issues often have to be considered [9] [17]. Applying front axle suspension to an articulated machine will cause the tractor to body roll because of the asymmetric load distribution. The hydraulic stabilizing system between the tractor and trailer counteract for some of the body roll movement. It is experienced that body roll movement of the tractor is uncomfortable when the suspension cylinder stroke difference (SCSD) is over 30mm when fully steered out, which require a side constraint to the optimization of the suspension. This is evaluated by a short simulation with and without load making a fully right turn.

Hereby 4 simulations are used to evaluate the quality of a configured suspension:

1. Fully right turn without load.
2. Fully right turn with load.
3. Travel without load at the ISO 5008 smooth track at $14km/h$.
4. Travel with load at the ISO 5008 smooth track $10km/h$.

Besides the side constraint of the SCSD, there are 7 other side constraints for the suspension system given by the chosen design and the supplier of the accumulators:

1. Maximum peak pressure should not exceed $p_0 \cdot PPR$ [15].
2. Maximum peak pressure should not exceed p_{per} [15].
3. p_0 should be higher than 90 percent of the minimum duty pressure [15].
4. The gas volume should not exceed $V_0 \cdot 0.9$ or be less than zero (2 constraints) [15].
5. The suspension cylinders should not reach the end stops (2 constraints).

The objective function as well as the contributions from the side constraint violations to the augmented objective functions are all normalized. The value of the augmented objective function appears by adding the whole-body vibration exposure with the square of all side constraint violations.

[13] and [14] suggest that the discrete design variables are handled as continuous and then, in order to obtain an optimal design that is actually useful to apply on real world applications, an integer evaluation number G_u is added to the augmented objective function:

$$G_u = \sum_{j=1}^2 \left(\frac{u_i - i}{\epsilon} \right)^2 \quad (11)$$

where i is the rounded integer value of u and ϵ is a parameter that is gradually reduced. In practice this is done by listing the discrete design variables in tables like Table 3 and Table 4 considering the index number at the left as the design variables and then interpolating between the rows when doing the evaluation.

To minimize $\Theta(\underline{y})$ the complex method first presented by [7] is applied. It is a non-gradient based mapping method that uses a population of design called a complex. The complex contains q design. Each configuration is evaluated with respect to Equation 9. Then the design with the highest objective value is changed. This is done by mirroring it in the center of the remaining design by:

$$\underline{y}_{new} = \kappa \cdot (\underline{y}_c - \underline{y}_{worst}) + \underline{y}_c, \quad \underline{y}_c = \frac{\sum_{i \neq worst}^q \underline{y}_i}{q - 1} \quad (12)$$

κ is called the reflection constant which is set to 1.3 as originally suggested by [7]. If the newly mirrored design continues to evaluate as the worst design it is moved toward the currently best design. The algorithm for this depends on the number of successive mirror operations that has returned the particular design as the worst design, k :

$$\underline{y}_{new} = \frac{1}{2} \cdot \left(\underline{y}_{worst} + \epsilon \cdot \underline{y}_c + (1 - \epsilon) \cdot \underline{y}_{best} \right) + \sigma \quad (13)$$

\underline{y}_{best} is the currently best design and ϵ is:

$$\epsilon = \left(\frac{n_r}{n_r + k - 1} \right)^{\left(\frac{n_r + k - 1}{n_r} \right)} \quad (14)$$

In Equation 14 n_r is a tuning parameter set to 4 and σ in Equation 13 is an extra term suggested by [6] that takes into account a situation where the centroid \underline{y}_c coincides with a local minimum of the objective function:

$$\sigma = (\underline{y}_c - \underline{y}_{best})(1 - \epsilon)(2 \cdot R - 1) \quad (15)$$

R is a random number between 0 and 1.

[7] suggests a population size that is twice the number of design variables and that is adopted here.

5 RESULTS

In figure 8 the development in the augmented objective function for the fittest member of the population is shown. The criteria of converge is that the difference between the best and worst configuration should be less than 0.01. When ϵ is reduced, an increasement of the fittest member is observed, and then the solution converge again but to a higher value than before.

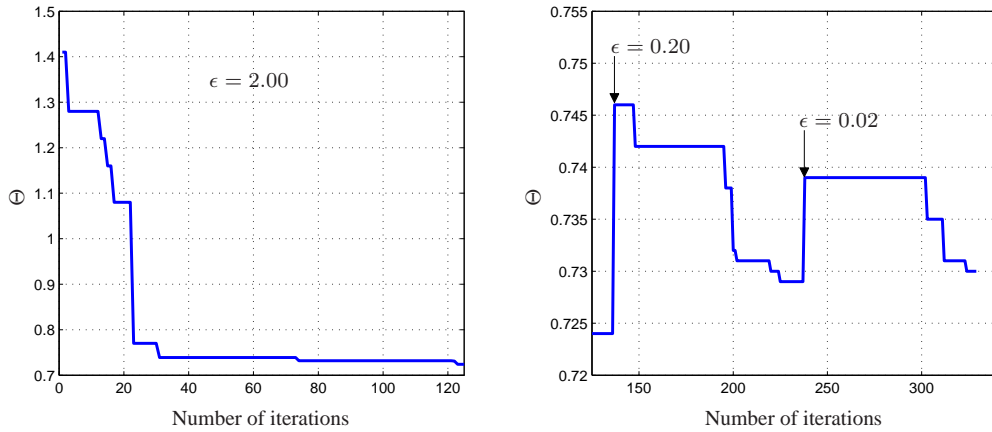

Figure 8. Development of augmented objective function value of fittest member.

In figure 9 the development of the cylinder diameter and the accumulator size are shown by table indices. The values moves toward integer values as wanted.

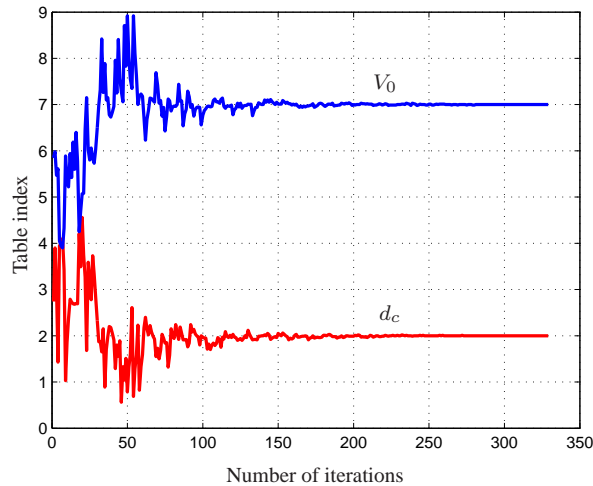

Figure 9. Development of the two discrete design variables.

In table 1 the optimized design of the suspension system is shown.

The final design is about twice as good as the best member of the start population. As no side constraints are violated in the final design the augmented object function value express the whole-body vibration exposure. Compared to the Hydrema dump truck without front axle suspension the

d_c	V_0	p_0	d_0	k	c_r
85mm	1l	23.4bar	3.23mm	$1.94 \cdot 10^6 \frac{N}{m}$	1.77mm

Table 1. Final optimized design.

whole-body vibration exposure on this specific track is decreased from $1.54m \cdot s^{-2}$ to $0.73m \cdot s^{-2}$, which is a significant improvement.

Since the polytropic exponent n can vary in a quite wide range [11] the whole-vibration exposure is evaluated for the final design propose with different sizes of the polytropic exponent. From table 2 a negliable difference in the vibration level is observed as function of the polytropic exponent size.

Polytropic exponent n	1.0	1.2	1.4	1.67
WBV level	0.729	0.728	0.730	0.731

Table 2. Vibration level with different operational sizes of the polytropic exponent.

In Appendix II a shorter simulation right front wheel hitting an 30mm obstacle is used to optimize the configuration of the suspension system in the same way as on the test track. It seems there is no significant difference in the final configuration for the 100m long test track and the single obstacle. The discrete design variables becomes the same as there is small deviation in the continuous variables. This indicates that the comfort number is independent of track length and much more dependant of the system eigenfrequency and avoiding end-stops of the suspension system, which is supported by [25].

6 CONCLUSIONS

By a non-gradient optimization method the optimum configuration of six design variables are fund for a hydro-pneumatic suspension system for an articulated dump truck. The evaluation criterion is a minimum level of whole-body exposure with a number of side constraints. Among these is the tolerable body roll when turning.

Two discrete design variables are handled as continuously and then an augmented objective restrict the design variables to become exact components in a library. Hereby it is demonstrate that discrete variables in design optimization of real world application can be done effectively.

Experimental work has been done to find operational values of the orifice equation and to ensure that the flow acts turbulent in order to have the right equation for the physical phenomena. The operational polytropic exponent though is difficult to determine. A sensitivity study has shown that the vibration value is very little dependent of the size of the polytropic exponent.

Optimization has been carried through with a 100m long standardized test track and a single small obstacle. The optimum design configuration becomes very similar. This result encourages using short simulations only in future work. This will decrease evaluation time for a design and though the overall development time.

For the specific problem the optimization routine has found that the accumulator with the highest volume gives the lowest whole-body vibration. This result call for an evaluation with accumulators with higher volume and then the design engineer must check out, if is possible to implement such a high volume accumulator.

ACKNOWLEDGEMENT

The authors would like to thank R&D Manager T. K. Iversen, A/S Hydrema Produktion for help, advice and cooperation on this work.

The research work is funded by an Industrial PhD-grant from the Danish Agency for Science, Technology and Innovation under the Danish Ministry of Science, Technology and Innovation.

REFERENCES

- [1] *ISO 2631-1 Mechanical vibration and shock Evaluation of human exposure to whole-body vibration Part 1: General requirements*. International Organization for Standardization, 1997.
- [2] *ISO 5008 Agricultural wheeled tractors and field machinery - Measurement of whole-body vibration of the operator*. International Organization for Standardization, 2002.
- [3] Aktiv vibrationsdæmpning. *Panorama* (2007), 14–15.
- [4] *ISO 25398 Earth-moving machinery - Guidelines for assessment of exposure to whole-body vibration of ride-on machines - Use harmonized data measured by international institutes, organizations and manufacturers*. International Organization for Standardization, 2008.
- [5] HSE information sheet: Whole-body vibration in quarries. <http://www.hse.gov.uk/vibration/wbv/quarries.pdf>, 2010.
- [6] ANDERSSON, J. A survey of multiobjective optimization in engineering design. Technical LiTH-IKP-R-1097, Department of Mechanical Engineering, Linköping University, Linköping, Sweden.
- [7] BOX, M. J. A new method of constraint optimization and a comparison with other methods. *Computer Journal* 8 (1965), 42–52.
- [8] CHRISTENSEN, B. B., AND LANGER, T. H. Experimental evaluation of whole body vibration on a hydrema 912DS dumper. Test report, A/S Hydrema Produktion, Støvring, 2009.
- [9] DUDZINSKI, P. Projektierung mobiler arbeitsmaschinen mit virtuellen und experimentellen methoden. Tech. rep., Technische Universität Wroclaw (Breslau).
- [10] FILLA, R., AND PALMBERG, J. O. Using dynamic simulation in the development of construction machinery. In *Proceedings of the Eight Scandinavian International Conference on Fluid Power* (Tampere, Finland, 2003).
- [11] GILIOME, C. L. Mathematical modelling of hydraulic accumulators. University of Pretoria etd, 2005.
- [12] GONZALEZ, F., GONZALEZ, M., AND CUADRADO, J. Weak coupling of multibody dynamics and block diagram simulation tools. In *Proceedings of the ASME 2009 International Design Engineering Technical Conference and Computers and Information in Engineering Conference* (San Diego (CA), USA, Sept. 2009), ASME.
- [13] HANSEN, M. R., AND ANDERSEN, T. O. Design optimization of hydraulically actuated lifting table using mapping techniques. In *Proceedings of the Ninth Scandinavian International Conference on Fluid Power SICFP* (Linköping, Sweden, June 2005).
- [14] HANSEN, M. R., AND ANDERSEN, T. O. A method for linked discrete design variables applied to lifting tables. In *Proceedings of the 12th AIAA/ISSMO Multidisciplinary Analysis and Optimization Conference* (Victoria, British Columbia Canada, Sept. 2008), American Institute of Aeronautics and Astronautics.
- [15] HYDAC. Diaphragm accumulators welded types. <http://www.hydac.com/de-en/products/hydraulic-accumulators/diaphragm-accumulators/diaphragm-accumulators-welded-types.html>.

- [16] JÖNSSON, P., AND LÖFROTH, C. RESULT: mobil provbana för standardiserad vibrationsmätning. Tech. Rep. 2, Skogforsk, Uppsala, Sweden, 2007.
- [17] LANGER, T. H. Analysis of the 912 pendulum bar length influence on load distribution. Calculation and analysis, A/S Hydrema Produktion, Støvring, Feb. 2010.
- [18] LANGER, T. H., AND BAK, M. K. Dynamic simulation for evaluation and improvement of ride comfort in a hydrema ADT, 2008.
- [19] LANGER, T. H., MOURITSEN, O. Ø., EBBESEN, M. K., AND HANSEN, M. R. A tire model for Off-Highway simulation and comfort evaluation. In *Proceedings of the ASME 2009 International Design Engineering Technical Conference and Computers and Information in Engineering Conference* (San Diego (CA), USA, Sept. 2009).
- [20] MAYTON, A. G. Evaluation of whole-body vibration exposures for haulage truck and loader operators in quarry operations. In *Proceedings of the ASME 2009 International Design Engineering Technical Conference and Computers and Information in Engineering Conference* (San Diego (CA), USA, Sept. 2009).
- [21] PARLIAMENT, E., AND OF THE EUROPEAN UNION, C. Directive 2002/44/EC of the european parliament and of the council of 25 june 2002 on the minimum health and safety requirements regarding exposure of workers to the risks arising from the physical agents (vibration).
- [22] RASMUSSEN, P. W., IVERSEN, F., HALLING, B., HOUNSGAARD, G., MØLBAK, H. G., KRISTENSEN, F. D., LYNGBÆK, E., RASMUSSEN, N. B., JESSEN, B. B., AND JANNERUP, O. *Hydraulik Ståbi*. Teknisk Forlag A/S, 1996.
- [23] RIMELL, A. N., AND MANSFIELD, N. J. Design of digital filters for frequency weightings required for risk assessments of workers exposed to vibration. *Industrial Health* 45 (2007), 512–519.
- [24] SAEKI, M. Path following control of articulated vehicle by backward driving. In *Proceedings of the 2002 IEEE International Conference on Control Applications* (Sept. 2002).
- [25] TOSCANO, J. Improving operator comfort. <http://www.sae.org/mags/sohe/6727>, Aug. 2009.

APPENDIX I

COMPONENT LIBRARY

This appendix contains tabel for standard sizes of hydraulic cylinders and hydraulic accumulators.

d_c	Piston Diameter [mm]
1	63
2	80
3	85
4	90
5	120

Table 3. Standard piston sizes.

V_0	Volume V_0 [L]	Permitted Operating Pressure p_{per} [Bar]	Permitted Pressure Ratio PPR
1	0.075	250	8
2	0.16	300	8
3	0.32	300	8
4	0.50	210	8
5	0.60	330	8
6	0.75	330	8
7	1.00	200	8
8	1.00	330	4

Table 4. Available accumulators sizes [15].

APPENDIX II

SHORT TRACK FOR OPTIMIZATION

This appendix contains optimization results when the dump truck hits only one single obstacle with right front wheel, Figure 10, for both empty and fully loaded machine.

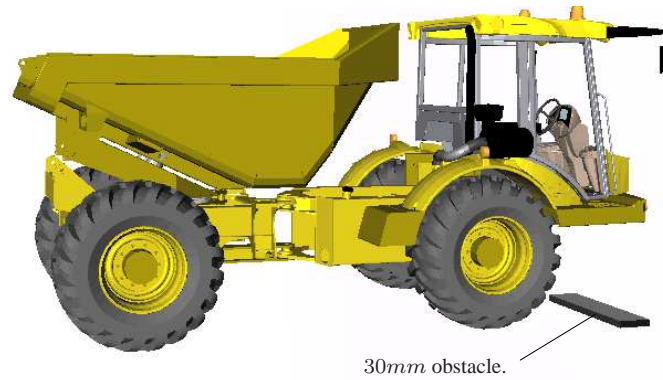

Figure 10. Single obstacle.

In Figure 11 the development in the augmented objective function for the fittest member of the population is shown. The criteria of converge is that the difference between the best and worst configuration should be less than 0.01. Convergence similar to Figure 8 is observed.

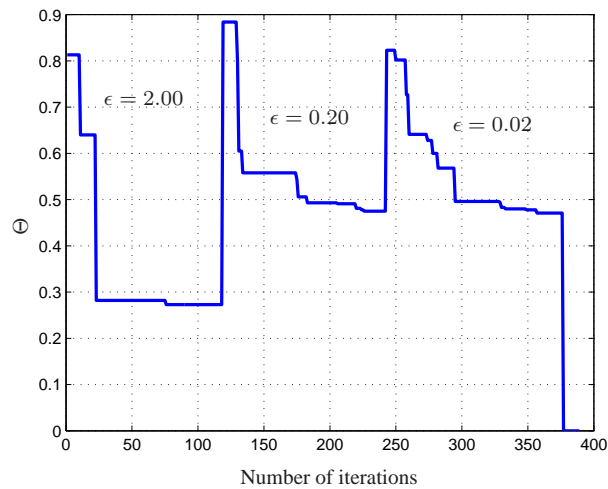

Figure 11. Development of augmented objective function value of fittest member.

In table 5 the optimized design of the suspension system is shown.

d_c	V_0	p_0	d_0	k	c_r
85mm	1l	26.6bar	3.32mm	$1.89 \cdot 10^6 \frac{N}{m}$	1.28mm

Table 5. Final optimized design.

In figure 12 the development of the cylinder diameter and the accumulator size are shown by table indices. The values moves toward integer values as wanted.

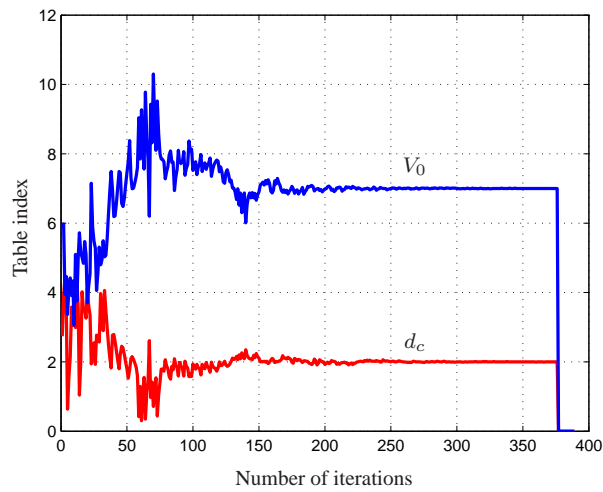

Figure 12. Development of the two discrete design variables.