



AALBORG UNIVERSITY
DENMARK

Aalborg Universitet

Power Routing

Active Asset Management in Power Electronics Systems

Peyghami, Saeed; Blaabjerg, Frede

Published in:
I E E Transactions on Industry Applications

DOI (link to publication from Publisher):
[10.1109/TIA.2022.3189329](https://doi.org/10.1109/TIA.2022.3189329)

Publication date:
2022

Document Version
Accepted author manuscript, peer reviewed version

[Link to publication from Aalborg University](#)

Citation for published version (APA):
Peyghami, S., & Blaabjerg, F. (2022). Power Routing: Active Asset Management in Power Electronics Systems. *I E E Transactions on Industry Applications*, 58(5), 6418-6427. Article 9822975. <https://doi.org/10.1109/TIA.2022.3189329>

General rights

Copyright and moral rights for the publications made accessible in the public portal are retained by the authors and/or other copyright owners and it is a condition of accessing publications that users recognise and abide by the legal requirements associated with these rights.

- Users may download and print one copy of any publication from the public portal for the purpose of private study or research.
- You may not further distribute the material or use it for any profit-making activity or commercial gain
- You may freely distribute the URL identifying the publication in the public portal -

Take down policy

If you believe that this document breaches copyright please contact us at vbn@aub.aau.dk providing details, and we will remove access to the work immediately and investigate your claim.

Power Routing: Active Asset Management in Power Electronics Systems

Saeed Peyghami, *Member, IEEE* and Frede Blaabjerg, *Fellow, IEEE*

Abstract—This paper proposes a power routing approach for active asset management in power electronic-based power systems. The proposed approach aims to expand the lifecycle of power converters as the key assets of modern energy systems. Moreover, it takes into account the operational costs of converter-based generation units in order to obtain economic dispatch in the system. As a result, the useful lifetime of converters is enhanced, thus improving the overall reliability of the system with respect to the operational costs of the generations. A numerical case study on a DC distribution system is presented to illustrate the effectiveness of the proposed approach.

Keywords— *asset management, reliability, power converter, power routing, operational cost, reliability cost-worth, lifecycle management.*

I. INTRODUCTION

Power electronics have become a key asset in modern interconnected power and energy systems. They can affect power systems performance in short- and long-term by posing stability [1] and reliability challenges. From a reliability perspective, power converters can be the source of failure, downtime and its costs in power systems [2]–[5] in the case they are not appropriately designed or operated. Thus, safe and secure operation of modern power systems require advanced asset management approaches for power converters.

Asset management in power electronics systems can be performed using short-, mid- and long-term approaches. The short-term methods are associated with control and stability issues. Furthermore, the mid-term approaches are subjected to the maintenance planning. The long-term asset management is related to the planning and design of power electronics systems. The main goal in these three levels is to enhance the reliability in converter and system level with respect to the planning and operation costs.

The converter reliability depends on various failure causes including catastrophic and wear-out failures [6]–[8]. The catastrophic failures are usually triggered by an extrinsic cause; thus, it is very difficult to model and mitigate them. Meanwhile, the wear-out failure mechanisms are intrinsic, and controllable. The wear-out failure in power converters is usually occur in power devices and electrolytic capacitors.

Various failure mechanisms in power devices and capacitors are summarized in [9]. According to field experience, these components are the most fragile components in various applications. Therefore, the converter reliability can be improved by preventing the aging of converter components.

There are several methods to enhance the reliability of converters which are essentially divided into three main categories of design, maintenance and control domains. Design and maintenance of converters is associated with the planning of microgrids, and the control of converters is attributed to the operation of microgrids. Therefore, their mechanisms on the reliability improvement will cover both short- and long-term effects. During design and manufacturing the converters, their components are selected according to a desired reliability performance, usually a life cycle with a specific probability of survival. Moreover, recently, system level design for reliability is presented to design a converter with respect to the power system performance, which takes into account the converter application and its function in power system [10], [11]. In addition to design for reliability, preventive maintenance approaches [12] can be employed during the planning of a microgrid in order to do cost-effective design of a converter for a specific period of mission.

Moreover, the converter reliability can be improved within operation using appropriate techniques such as adaptive switching frequency [7], advanced switching techniques, reactive power routing [13], [14] and preventive maintenance and active power sharing [15]. Furthermore, condition monitoring and fault diagnostics during operation can help enhancing the reliability of converters [16]–[18]. Moreover, power routing among converters based on their thermal stresses or loading conditions can have remarkable impact on the system reliability as it can dynamically distribute the thermal damages of the converters among them [14], [15], [19]. This concept indeed act as an online and active maintenance where the loading of highly damaged units can be moved to the converters with low thermal damage.

The power routing among DC-DC converters based on reliability considerations monitoring an state of the health indicator is addressed in [15], [19]. Furthermore, reactive power sharing based on the thermal damage of the converters in AC microgrid is presented in [14]. In practice, shifting the load of highly damaged converter to a lowly damaged one may introduce extra operation costs. Notably, operational cost-based power routing in microgrids has already addressed in [20]. However, the state of the health of units is not considered

This work was supported by VILLUM FONDEN under the VILLUM Investigators Grant called REPEPS at the Department of AAU Energy, Aalborg University, Aalborg, Denmark.

The authors are with the Department of AAU Energy, Aalborg University, Aalborg, Denmark (e-mail: sap@energy.aau.dk, fbl@energy.aau.dk).

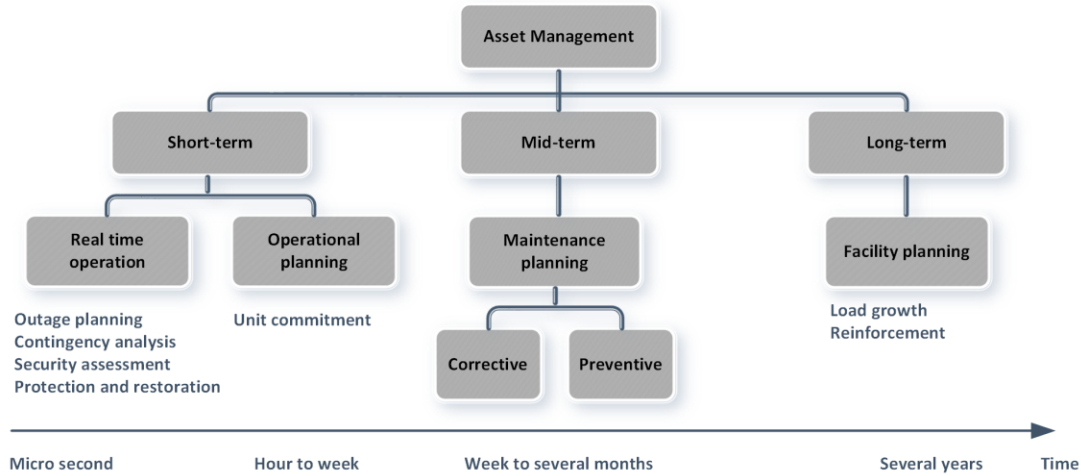

Fig. 1. Multi-time scale asset management in modern power systems.

in this study. Therefore, in spite of lower operational costs, the lifecycle of converters and overall system reliability can be deteriorated. As a result, highly damaged converters may need early replacement in order to reduce the system risk. This will intern introduces operational planning costs associated with the maintenance of converters. Thus, appropriate asset management technique is required to address the operational costs and reliability of power converters in order to optimize net benefits [21].

This paper will propose an active asset management method for power electronic-based power systems using an appropriate power routing strategy. The proposed approach will enhance the converter and system reliability with respect to the operational costs. The remainder of this paper is organized as follows. Section II presents the concept of asset management in power electronics system in different time scales. Section III presents the details of the proposed power routing method as an active asset management strategy in power electronics systems. The effectiveness of the proposed approach is illustrated on a DC power electronic-based power system in Section IV. Finally, the outcomes are summarized in Section V.

II. ASSET MANAGEMENT IN MODERN POWER SYSTEMS

According to ISO 55000, asset management generally refers to a coordinated activity of an organization to realize value from assets. Furthermore, based on CIGRE joint Task Force JTF23.18, asset management in power systems is the central key decision-making for the power system assets to maximize long-term benefits with respect to high level of service quality, and acceptable level of risk. To achieve these goals, asset management in power networks is classified into three categories; short, mid, and long-term as shown in Fig. 1.

A. Short-term asset management

Short-term asset management in power systems refers to time intervals of several hours down to microseconds. The

activities in short-term asset management is divided into operational planning and real-time operations. Operational planning refers to the utilization of existing facilities in the power network to support the grid demand in next hour/hours. This is performed based on economic dispatch with respect to the desired system reliability. According to the forecasted demand, available units, generation and operation costs, emission costs, etc., the optimization is performed and generation scheduling is carried out using a unit commitment program.

Then, the selected facilities with the planned conditions will be operated in real time. These facilities are managed in such a way that the short-term performance of the system is achieved. Short-term performance includes power quality, stability and operational reliability. The main concern in this stage is system security which is related to the asset outage management. Power systems must be operational due to any sudden contingency in the system. Thus, contingency analysis needs to be performed to ensure system safe and secure performance. This include both static performance such as power quality, e.g., voltage and frequency violations, as well as dynamic performance including different types of stability. The relevant asset management activity in this level is called security assessment and management. The operator will analyze the system security level based on any likely contingency and plan any remedial action for any case of an unsecure event. Remedial actions could be corrective or preventive according to the severity of the outage. Some preventive actions could be network splitting and generation rescheduling, etc. Moreover, corrective approaches could be isolating faulty regions, load shedding, etc. Protection approaches against faults to protect devices and customers, as well as restoration of isolated areas, can be part of corrective security management.

B. Mid-term asset management

Furthermore, operation of huge number of devices in power

systems which are supposed to work for ever to deliver power to the customers requires appropriate maintenance methods to guarantee acceptable level of risk in the system. The system devices are prone to wear-out. Furthermore, improper operation may deteriorate their performance. Moreover, some devices have limited lifecycle due to physical limitation of materials. Therefore, malfunction of these devices may cause power loss and even power cut in the network. In order to prevent or at least reduce the impact of above-mentioned factors on the risk of system, appropriate maintenance activities are required. In some references this is called life cycle management, or even asset management. In this paper, it is called mid-term asset management as shown in Fig. 1, since maintenance is usually performed in the time interval of a few months to one year.

There are two types of maintenance in power systems; corrective and preventive. Corrective maintenance, so-called run-to-fail maintenance or reactive maintenance, is performed after a failure occurrence. This is the easiest technique but the most non-optimal one among maintenance approaches since it introduces higher downtime and costs. The main goal of corrective maintenance is to return the system to the operation state regardless of downtime. In contrary, preventive maintenance, as it is obvious from its title, refers to the maintenance activities to prevent failure occurrence using proper techniques. This strategy can be performed: (1) in a fixed calendar time, (2) variable time based on an indicator related to the system life, and (3) based on the state of health of the system. In the first approach, based on the operator experience in different cases, fixed time is considered to repair/replace the devices. In the second one, the devices are maintained based on time in-use like the number of kilometers in a car to change the engine oil, or the number of cycles to failure in a battery/semiconductor device. The drawback of these two approaches is that they are not optimal and cost-effective as they do not monitor the real health state of the device. Depends on the failure and degradation mechanisms, a device may be replaced much earlier than its end-of-life or may fail before maintenance. Therefore, predictive maintenance is introduced to monitor to state of health of a device using a proper life indicator, e.g., on state collector-emitter voltage in a semiconductor device, to predict the residual life and then plan for its maintenance. Notably, the preventive maintenance is applied for aging failures, while catastrophic failures which are not detectable by an indicator, needs to be managed by corrective maintenance after failure occurrence. This needs spare unit management to ensure acceptable level of system risk.

According to the maintenance strategies, various maintenance actions can be taken to reduce the system risk. Depending on the component characteristics, failure type and residual life, the applied action can be passive or active. For instance, in a component with a redundant structure, e.g., redundant power converter, it can be operated in a de-rated mode until the failure clearance. This approach can be an active solution for reducing the system risk. Another active

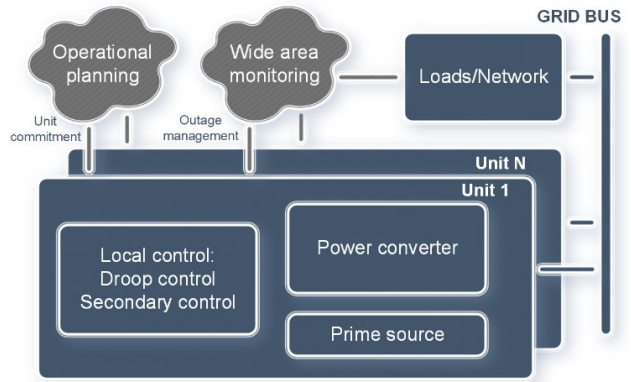

Fig. 2. Short-term asset management in power electronics-based power systems; control and operational planning.

approach can be reduction of stress level in a device with high degradation process employing health indicator. This approach can be part of predictive maintenance, where until taking a proper decision making, de-loaded operation can actively reduce the system risk. This technique is used in this paper for reducing the risk of failure in power electronic-based power systems. For instance, in a generator with aged shaft, de-loaded operation until proper maintenance action can reduce the risk of loss of whole generation. In other words, maintenance may take time due to component delivery, expert personal availability, high-level decision-making process, thus in this case de-loaded operation is better than full-load operation with the high risk of outage. Moreover, passive approaches can be repair or replacement of a component based on a maintenance strategy.

C. Long-term asset management

Furthermore, the next phase of asset management is the long-term facility planning. This phase is associated with the development, expansion and reinforcement of power grids considering load growth, emerging technologies, grid modernization, etc. This phase requires long-term technical, technological, economical and societal analyses for decision-making for adding new facilities, extending power grids, etc.

This paper focuses on the short-term and mid-term asset management in power electronic-based power systems. The basic structure of short-term asset management in modern power electronic-based power systems is shown in Fig. 2. This includes operational planning for economical and reliable power sharing among different units. The scheduled reference signals are sent to the units. The units regulate the output power accordingly. Furthermore, the units are responsible for voltage and frequency regulation based on their participation in the grid control defined by the operator. Moreover, the wide area monitoring system is employed to monitor the status of the grid in terms of voltage, frequency, component outage, load, fault, etc., to help the operators for properly managing the system security.

The goal in short-term asset management is to

economically dispatch the load among converter-based units considering the operational costs of prime sources. Furthermore, the goal in mid-term is to extend the lifecycle of power electronics converters by appropriately monitoring converter health status and then expanding their lifetime by preventing overstressing the converters. This can be part of preventive maintenance where by an active strategy, the converter lifetime is extended. Notably, the converter lifetime expansion is carried out with respect to the operational costs of units. Thus, the converter-based generation units as the key assets of power system can actively be managed to optimally and reliably operate. This can not only expand the lifetime of the power converters, but also enhance the reliability and reduce the power system risks in an optimal way with respect to the operational costs. The proposed asset management approach is explained in the following section.

III. PROPOSED POWER ROUTING FOR ACTIVE ASSET MANAGEMENT

Fig. 3 shows the proposed short- and mid-term asset management structure for a converter-based generation. The proposed approach includes three main parts:

- 1- Real-time power routing approach,
- 2- Converter lifetime expansion with proper health monitoring,
- 3- Economic dispatch modeling operational costs in short-term.

According to the proposed approach, the power sharing of generation units is performed based on the operational costs of prime energy source and the reliability of the converters as the fragile components in the system. First, the thermal damage of the converters is calculated. A life indicator such as thermal damage or residual life is then obtained. This indicator can be periodically calculated, e.g., every hour or every month. For the units with high damage, the stress level will be reduced by de-loading the unit. However, this may cause additional operational costs for other units carrying the de-loaded demand. Thus, in the next step, the operational cost of generation unit is modeled and according to the output power of units, the operational costs for the shared demand is obtained. Finally, a power routing approach is employed to adjust the output power of the units to reduce the operational costs and thermal damage of the units. As a result, the lifecycle of converters is enhanced and the operational costs are optimized. The details of the proposed approach are explained in the following sub-sections.

A. Proposed power routing approach

The proposed power routing approach relies on the droop control method. According to the droop approach, the frequency can be proportionally controlled by output power in AC grids following (1), where ω , ω_0 are the actual and reference angular frequency, k_p is the droop gain and P is the output power. Similarly, in DC grids, the voltage is controlled proportional to the output power following (2), where V , V_0 are the actual and rated DC voltages.

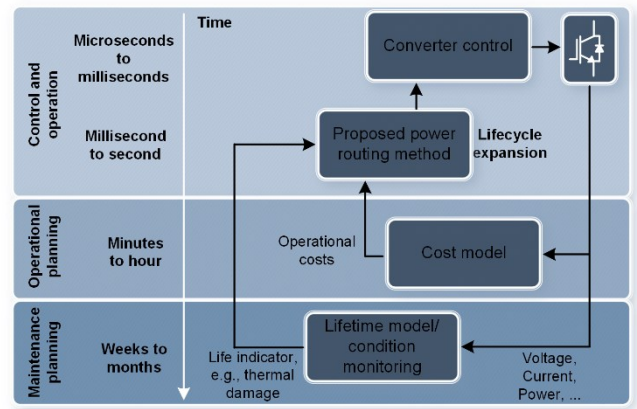

Fig. 3. Proposed active asset management in power electronics-based power systems.

$$\omega = \omega_0 - k_p P \quad (1)$$

$$V = V_0 - k_p P \quad (2)$$

Obviously, there are different methods to perform power routing where their static performance will be identical to the droop methods. Therefore, from reliability and operational cost perspective, their performance is identical. Thus, in this paper, the basic form of these controllers is employed and it is called conventional method in this paper.

This technique takes into account the rated power (current) of the units to prevent overloading. However, according to the lifetime of power devices, not only does the load level affect its reliability, but also the loading fluctuations may limit the life expectancy of power converters [4]. Thus, even the conventional approach prevents the overloading of converters, it may not avoid overstressing and aging of units [14]. Therefore, the reliability-oriented methods have been presented to address this issue, where the loading of converters are controlled using (3) and (4) for AC and DC grids [14], [15].

$$\omega = \omega_0 - \frac{D}{D_{max}} P \quad (3)$$

$$V = V_0 - \frac{D}{D_{max}} P \quad (4)$$

where D is the thermal damage of corresponding unit and D_{max} is the maximum damage of the units. According to this method, the loading of highly damaged unit is shifted to the lowly damaged one. This can improve the system reliability while it may cause higher operational costs. In fact, there is a compromise between reliability and operational costs in microgrids. To address this issue, the reliability/cost-based control approach is proposed in this paper.

$$\omega = \omega_0 - \frac{D}{D_{max}} \frac{C}{C_m} P \quad (5)$$

$$V = V_0 - \frac{D}{D_{max}} \frac{C}{C_m} P \quad (6)$$

where C is the operational cost of corresponding unit and C_{max} is the maximum operational cost of the units in the grid. Notably, the damage and cost values are updated in on hourly base. This can be done either in a central way using central control unit, or distributed way, sharing the data among sources, or independently using a fixed value for D_{max} and C_{max} . In this paper, the third approach is adopted, however, this can reduce the response time, while it does not require a communication system. In the following, the converter damage analysis and operational costs model are presented.

B. Converter lifecycle model

The reliability and damage of a converter depends on its loading and climate conditions [22]. These conditions cause wearing out of converter components, thus limiting its useful lifetime. According to the field returned data, capacitors and semiconductor devices are the two most fragile components in power converters [23]–[25]. The semiconductors lifetime can be modeled as the number of cycles to failure, N that the device withstands without according a failure. According to (7), this depends on the junction temperature variations ΔT_j , its minimum value T_{jm} , and its heating time t_{on} [26], [27].

$$N = A \cdot \Delta T_j^\alpha \cdot \exp\left(\frac{\beta}{T_{jm} + 273.15}\right) t_{on}^\gamma \quad (7)$$

where A , α , β , and γ are obtained based on field experience or from lifetime tests [26], and $A = 9.34E14$, $\alpha = -4.416$, $\beta = 1285$, and $\gamma = 0.3$. Thereby, the thermal damage of a semiconductor device is obtained using minor rules as:

$$D^{(sem)} = \sum_t \frac{n_t}{N_t} \quad (8)$$

where $D^{(sem)}$ denotes the thermal damage on the semiconductor devices experiencing n_t power cycles within the period of t . Moreover, N_t is the number of cycles to failure in the applied loading profile which is associated with T_{jm} , ΔT_j , and t_{on} obtained from (7). The wear out of power devices such as Insulated-Gate Bipolar Transistor (IGBT) and diodes can be obtained using (8).

Moreover, the wear out of the capacitors can be estimated employing its lifetime model, e.g., using lifetime model represented in (9) [28].

$$L_w = L_r \cdot 2^{\frac{T_r - T_w}{n_1}} \left(\frac{V_w}{V_r}\right)^{-n_2} \quad (9)$$

where, L_r , V_r , and T_r , denote the nominal lifetime, voltage and temperature of capacitor, and $L_r = 5000$ hour, $V_r = 450V$, and $T_r = 105^\circ C$, $n_1 = 10$, $n_2 = 3$. Moreover, L_w , T_w , and V_w are the lifetime consumption, temperature and voltage due to applied mission profile. As a result, the capacitor damage, $D^{(cap)}$ under given operational conditions can be obtained as:

$$D^{(cap)} = \sum_t \frac{\Delta T_w}{L_{w,t}} \quad (10)$$

where, ΔT_w is the time interval w that the capacitor experiences T_w , and V_w and the corresponding lifetime consumption will be L_w based on (9).

Finally, the average thermal damage per converter's component, D , is obtained as:

$$D = \frac{1}{M^{(sem)} + M^{(cap)}} \left(\sum_j^{M^{(sem)}} D_j^{(sem)} + \sum_j^{M^{(cap)}} D_j^{(Cap)} \right) \quad (11)$$

where, M denotes the number of each component in the convert.

C. Operational costs model

The operational costs of energy units depend on different factors based on the initial energy source, environmental pollutions, maintenance costs, etc. Operational costs, C are usually modeled by a second-order quadratic expression as [20]:

$$C(P_x) = a + b \cdot P_x + c \cdot P_x^2 \quad (12)$$

where, the term a is in charge of no-load costs, b is associated with the maintenance costs, c is attributed with the fuel and emission costs. During shifting the load of one unit to the other unit the decremental cost of first unit will be smaller than the incremental costs of the second one. Therefore, load adjustment may improve the reliability of the system, while it can introduce higher operational costs.

The proposed approach relies on optimizing the reliability per costs of operation in the system. According to this approach, the unit with higher thermal damage should support lower power to enhance the system reliability. On the other hand, the unit with higher operational costs will support low power to decrease the overall operational costs. As a result, there is a compromise between operational costs and the reliability of the system, and the system can be operated in an optimal point maximizing the reliability while minimizing the operational costs. This can be implemented by an advanced droop control given in (5) and (6) for AC and DC grids. In the following a case study is provided in DC grid to show the performance of the proposed control scheme to enhance the reliability and costs of operation.

D. System reliability model

In order to illustrate the impact of proposed power routing on the overall reliability of the system, the power system risk assessment approach is adopted in this paper [29], [30]. According to the system level reliability, the unavailability of different units needs to be analyzed. The unavailability is the probability that a components or system is in down state. According to this definition, it is important to analyze the current state of the component regardless of failure occurrence in past operation. To model this concept, the unavailability, U is defined as (13):

$$U = \frac{\lambda}{\lambda + \mu} \quad (13)$$

where λ and μ are the failure rate and repair rate of the component. The failure rate is calculated based on stress-strength analysis and the damage analysis given in (8) and (10) for converter components. The reader can find procedure of failure rate prediction for power converters in [31]. Meanwhile, repair rate is the reciprocal of the time spent to repair or replace a component. Therefore, it is essential to bring up a component once it fails and the unavailability is the function of both failure frequency and replacement time.

Once the availability of the components and units have been obtained, their probability can be convolved with the load profile to obtain the number of hours per year that the load cannot be supplied due to the power shortage. This is called Loss Of Load Expectation (LOLE), which can be calculated using (14) [32]:

$$LOLE = \sum_{i=1}^{8760} P_i(C_i < L_i) \quad (14)$$

where, P_i is the probability that the load L_i is greater than the generation capacity C_i at time interval i over the 8760 hours of a year. P_i is the function of a combination of the unavailability of different generation units. More detail expression on how to calculate LOLE is provided in [31].

IV. DC DISTRIBUTION SYSTEM CASE

In this section, a simulation on a DC power electronic-based power system is presented. The DC grid includes a solar photovoltaic (PV) unit, fuel cell (FC) stack, microturbine (MT) and battery storage as shown in Fig. 4. The structure of the energy sources is shown in Fig. 5. The PV system specifications are given in TABLE I. The solar irradiance and ambient temperature are shown in Fig. 6(a, b) respectively. Furthermore, the annual load profile is shown in Fig. 6 (c). The operational cost of energy units is given in Fig. 7 according to cost model expressed by (12). Moreover, the converter specifications are summarized in TABLE II. Notably, the proposed approach is applicable for AC power systems as well without losing generality. Worth to mention that in the analysis the battery charging/discharging efficiency is considered to be 100% with fast ramp rate.

To performed the analysis, the converters are simulated in Matlab Simulink to analyze their thermal behavior. The thermal characteristics are, then, used in a program in Matlab to perform power flow analysis. Once the power flow analysis is done, the mission profiles are obtained and the system level reliability analysis and cost worth analysis are carried out to demonstrate the effectiveness of the proposed approach on the system performance.

TABLE I PV SYSTEM SPECIFICATIONS.

Parameter	Value
Panel Rated Power	345 W
Number of Series panels in string	5
Number of Parallel strings	3
Open Circuit Voltage	64.8 V
Short Circuit Current	7.04 A
MPPT Voltage	54.7 V
MPPT Current	6.26 A
Voltage temperature Coefficient	-0.27 %/K
Current temperature Coefficient	0.05 %/K

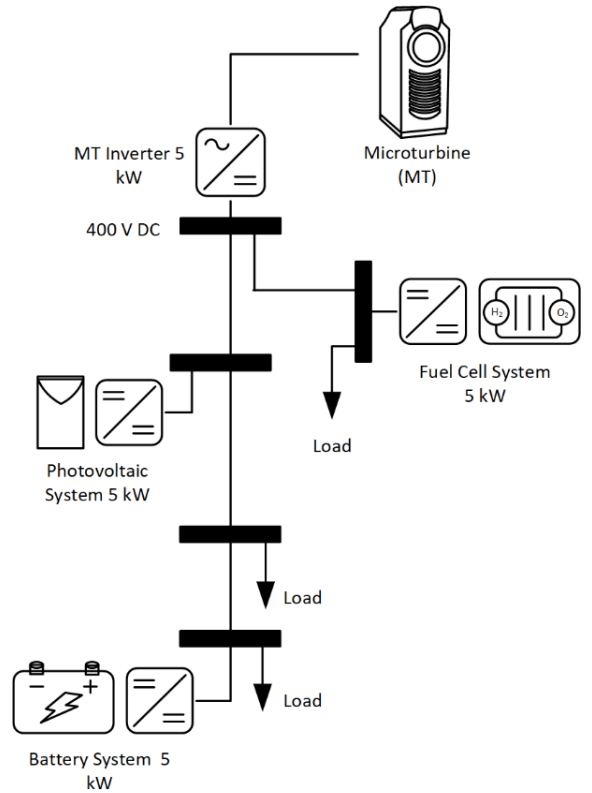

Fig. 4. Structure of a DC power electronic-based power system with different converter topologies and energy sources.

The converters reliability functions under the given mission profiles shown in Fig. 6 and energy management strategies is predicted using stress-strength analysis presented in [31]. Afterwards, the converters unavailability functions are obtained. The unavailability of converters under three power sharing strategies is illustrated in Fig. 8. It is shown in Fig. 8(a and b) that by using a reliability-oriented load sharing approach compared to the conventional one the unavailability of FC and battery is decreased.

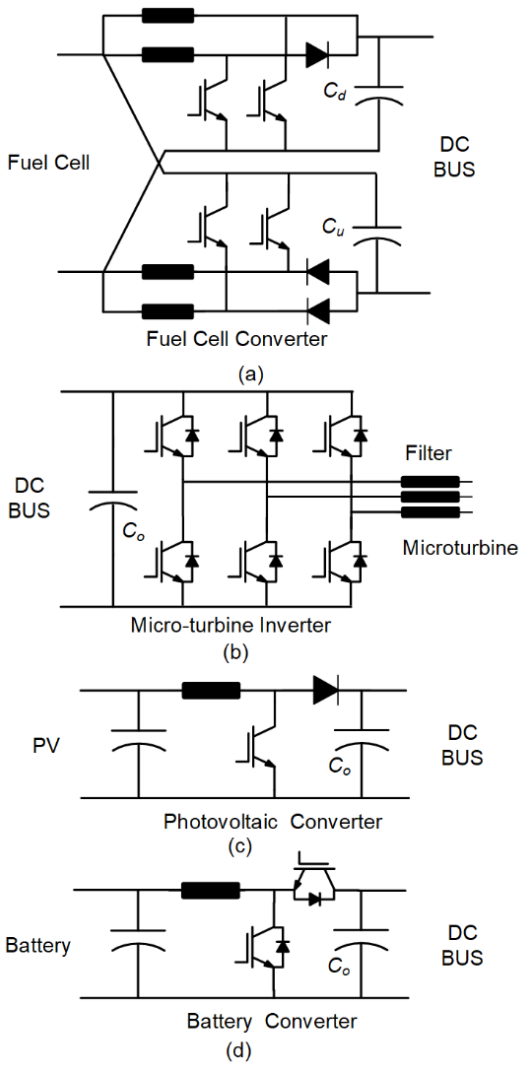

Fig. 5. Structure of a DC power electronic-based power system with different converter topologies and energy sources.

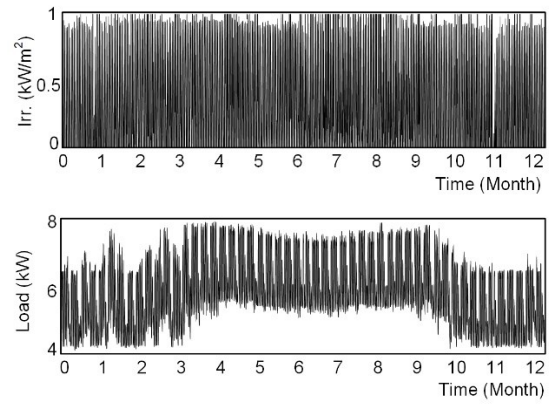

Fig. 6. Annual mission profiles: (a) solar irradiance (Irr.) and (b) accumulated load profile.

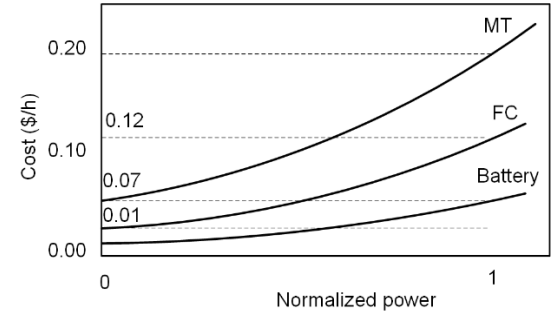

Fig. 7. Operational cost of different units shown in Fig. 4.

Moreover, the unavailability of the MT is increased, which implies the shifting of the load of battery and FC to the MT. As a result, the system reliability measured by LOLE (loss of load expectation) is decreased as shown in Fig. 9. LOLE shows the number of hours per year that the load cannot be supplied due to the failure of any components, thus the lower LOLE indicates the higher system reliability. According to Fig. 9, if the standard level of LOLE to be considered as 8 h/y, then, the system reliable span – the period that the system stays reliable – is 16 years. This means the reliability-oriented

TABLE II POWER CONVERTER COMPONENT AND SPECIFICATIONS.

Converter Parameters	Microturbine (MT)	PV Converter	FC Converter	Battery Converter
Rated power	5 kW	5 kW	5 kW	5 kW
Switching frequency	20 kHz	20 kHz	20 kHz	20 kHz
DC Bus voltage	400 V	400 V	400 V	400 V
Input voltage	150 Vac, (50 Hz)	220 – 320 Vdc	72-110 Vdc	300-335 Vdc
Output capacitor	2×220 μF (C _o)	2×220 μF (C _o)	5×220 μF (C _u , C _d)	2×220 μF (C _o)
ESR per capacitor @ 100 Hz	0.41 Ω	0.35 Ω	0.24 Ω	0.41 Ω
Capacitor thermal resistance, and time constant	19.5 K/W 10 min	19.5 K/W 10 min	28 K/W 10 min	19.5 K/W 10 min
DC inductor	-	1 mH	1 mH	1 mH
IGBT	IGB20N60H3	IGB10N60T	IGB15N60T	IGB15N60T
Diode	IDV15E65D2	IDV20E65D1	IDV20E65D1	IDV15E65D2
Battery capacity	-	-	-	2000 Ah

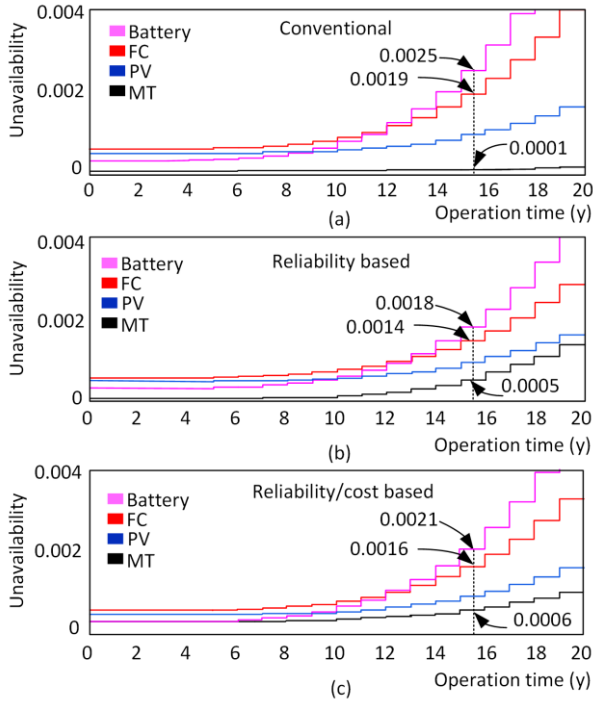

Fig. 8. Unavailability of converters due to wear-out failure under load sharing schemes of (a) conventional, (b) reliability-oriented and (c) reliability/cost-based.

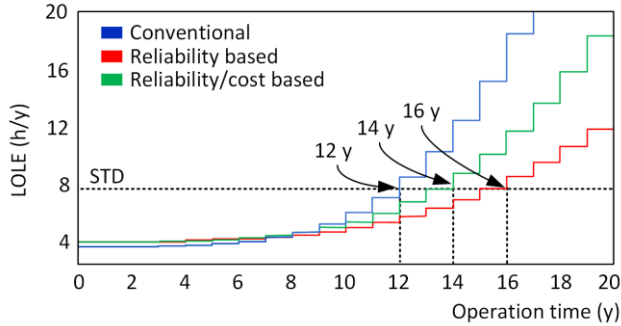

Fig. 9. Overall reliability (LOLE) of the microgrid shown in Fig. 4.

approach extends the system reliable span by 4 years. Moreover, the operational costs of units are summarized in TABLE III. Using the reliability-oriented approach, increases the overall operational costs by 21% according to TABLE III.

The unavailability function of units using the proposed reliability/cost-based approach is shown in Fig. 8(c). The unavailability function of battery and FC is lower than the conventional approach shown in Fig. 8(a). Meanwhile, it is higher than the reliability-oriented technique shown in Fig. 8 (b). The overall system reliability measured by LOLE is improved compared to the conventional one as shown in Fig. 8. However, reliability enhancement compared to the reliability-oriented technique is limited. As shown in Fig. 8, the system becomes unreliable after 14 years using the proposed method. Moreover, the operational costs are given in TABLE III, where it is 6% higher than the conventional approach, while it is 15% lower than the reliability-oriented

TABLE III ANNUAL OPERATIONAL COSTS (\$/y).

Power Sharing Strategy	Conventional	Reliability oriented	Reliability/cost based
Fuel cell (FC)	1,100	830	955
Battery storage	530	430	485
Microturbine (MT)	1,235	2,215	1,590
Total	2,865	3,475(21%)	3,030(6%)

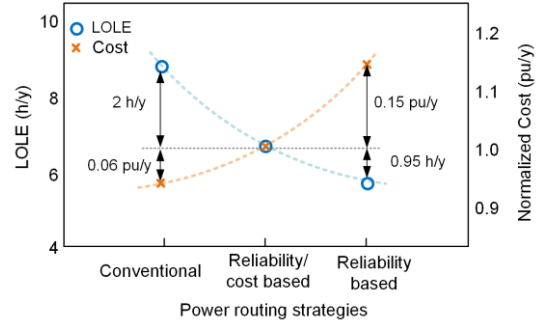

Fig. 10. Reliability cost-worth analysis, LOLE: loss of load expectation (reliability index), and the cost in per unit (pu) represents the operational costs normalized per 3,000 \$.

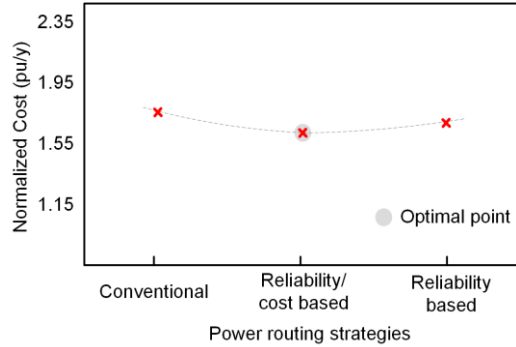

Fig. 11. The normalized total cost of reliability and operation. Costs are normalized per 3,000 \$ - VOLL is 35 \$/kWh.

technique. This case study shows that there is a compromise between reliability and operational costs of units.

These results for the 12th year of operation are presented in Fig. 10. The LOLE shows the system reliability in 12th year, where the lower LOLE shows a better reliability. Following Fig. 10, the LOLE is decreased by using the reliability/cost-based approach and the reliability-oriented approach respectively. Meanwhile, the operational costs are increased for the case of employing reliability/cost-based and reliability-oriented methods. Therefore, higher reliability demands for higher costs. However, the cost of reliability enhancement in more reliable conditions is higher than less reliable conditions. As shown in Fig. 10, improving the reliability by 2 h/y form conventional approach to the reliability/cost-based approach needs 6% of annual operation costs, while improving the reliability from reliability/cost-based approach to the reliability-oriented approach by 0.95 h/y demands for 15% of

operation costs. While the reliability enhancement is almost halved, the corresponding costs are almost tripled. This is due to the fact that, in this case, the MT need to provide more power as its damage is low as it is also shown in Fig. 6(a), while its operational cost is high according to Fig. 9. Therefore, it is of high importance to provide reliability worth-cost analysis to find an optimal point where the reliability is enhanced with minimizing the operational costs.

In order to find the optimal approach from economic perspective, the LOLE is converted to the unreliability cost by the concept of Value of Lost Load (VOLL). This indicator measures the cost of damage due to the power shortage [33], [34]. There are different approaches to calculate power shortage damage. In this paper a simple approach is adopted to illustrate the impact of power routing strategy on system performance [33]. In general, the cost of unreliability can be obtained by:

$$C_{damage} = P \cdot LOLE \cdot VOLL \quad (15)$$

where P is annual peak load in kW and VOLL is value of lost load in \$/kWh. VOLL depends on the load type and it has different values for different countries and it varies from 3 to 60 \$/kWh. An average VOLL equal to 35 \$/kWh is considered and the total cost of system including cost of damage and cost of operation is illustrated in Fig. 11. It is obvious that the reliability-cost based approach gives lower costs and is an optimum approach. However, there is an upper limit for costs or damage on the converter depends on the converter parameters, operating conditions and operational costs. In the boundary conditions, this approach will tend to either conventional approach if the costs of operation is high, or reliability-based method if the damage is high. This is automatically performed by the proposed droop control.

Therefore, employing the proposed approach enhances the reliability of the system with respect to the operational costs of the units. Unlike the conventional power sharing approach for power electronic-based systems, the proposed approach takes into account the thermal damage of the units and their operational costs. Therefore, not only it prevents the overloading and over-stressing the units, but also it enhances the overall system reliability, and at the same time decreases the operational costs. This method can automatically provide operational planning services such as reliability services, economic dispatch, and autonomous operation to the islanded microgrids specially, thus enhancing self-organizing capability of power electronic systems.

V. CONCLUSION

This paper has proposed an active asset management approach using an adaptive power routing method for power electronic-based power systems. The proposed power routing approach takes into account the operational costs in order to achieve economic dispatch among converter-based units as well as the state of health of power converters to extend their lifecycle. Therefore, not only it prevents the overloading and

over-stressing converters, thus enhancing the overall system reliability, but also it optimizes the operational costs of generation units.

According to the numerical analysis on a DC distribution system, moving from conventional to reliability based- power routing approach, the system risk, i.e., LOLE, is decreased from 8.60 h/y to 5.65 h/y, thus the system reliability is improved. However, the operational costs are increased by 21% per annual operation costs. Meanwhile, the proposed power routing approach enhances the lifetime of the converters by appropriately sharing the thermal stresses over converters with respect the operational costs. This approach introduces better system reliability, 2 h/y lower LOLE compared to the conventional approach, and lower operational costs, 15% compared to the reliability-oriented approach. The impact of early replacement costs added to the operational costs and maintenance strategies together with the de-loaded operation of PV system and its contribution in system reliability and operational costs will be focused in the future work.

REFERENCES

- [1] IEEE PES-TR 77, "Stability Definitions and Characterization of Dynamic Behavior in Systems with High Penetration of Power Electronic Interfaced Technologies," 2020.
- [2] M. Wilkinson and B. Hendriks, "Report on Wind Turbine Reliability Profiles," 2011.
- [3] L. M. Moore and H. N. Post, "Five Years of Operating Experience at a Large, Utility-Scale Photovoltaic Generating Plant," *Prog. Photovoltaics Res. Appl.*, vol. 16, no. 3, pp. 249–259, 2008.
- [4] H. S. Chung, H. Wang, F. Blaabjerg, and M. Pecht, "Reliability of Power Electronic Converter Systems," First Edi. London: IET, 2016.
- [5] J. Falck, C. Felgmacher, A. Rojko, M. Liserre, and P. Zacharias, "Reliability of Power Electronic Systems," *IEEE Ind. Electron. Mag.*, vol. 12, no. 2, pp. 24–35, Jun. 2018.
- [6] K. Ma, M. Liserre, F. Blaabjerg, and T. Kerekes, "Thermal Loading and Lifetime Estimation for Power Device Considering Mission Profiles in Wind Power Converter," *IEEE Trans. Power Electron.*, vol. 30, no. 2, pp. 590–602, Feb. 2015.
- [7] M. Andresen, G. Buticchi, and M. Liserre, "Study of Reliability-Efficiency Tradeoff of Active Thermal Control for Power Electronic Systems," *Microelectron. Reliab.*, vol. 58, pp. 119–125, Mar. 2016.
- [8] H. Wang, M. Liserre, F. Blaabjerg, P. de Place Rimmen, J. B. Jacobsen, T. Kvisgaard, and J. Landkildehus, "Transitioning to Physics-of-Failure as a Reliability Driver in Power Electronics," *IEEE J. Emerg. Sel. Top. Power Electron.*, vol. 2, no. 1, pp. 97–114, Mar. 2014.
- [9] S. Peyghami, Z. Wang, and F. Blaabjerg, "Reliability Modeling of Power Electronic Converters: A General Approach," in *Proc. IEEE COMPEL*, 2019, pp. 1–7.
- [10] N. C. Sintamarean, F. Blaabjerg, H. Wang, F. Iannuzzo, and P. De Place Rimmen, "Reliability Oriented Design Tool for the New Generation of Grid Connected PV-Inverters," *IEEE Trans. Power Electron.*, vol. 30, no. 5, pp. 2635–2644, 2015.
- [11] H. Wang, K. Ma, and F. Blaabjerg, "Design for Reliability of Power Electronic Systems," in *Proc. IEEE IECON*, 2012, pp. 33–44.
- [12] S. Peyghami, F. Blaabjerg, J. R. Torres, and P. Palensky, "Maintenance Scheduling in Power Electronic Converters Considering Wear-out Failures," in *2020 22nd European Conference on Power Electronics and Applications, EPE 2020 ECCE Europe*, 2020, pp. 1–10.
- [13] K. Ma, M. Liserre, and F. Blaabjerg, "Reactive Power Influence on the Thermal Cycling of Multi-MW Wind Power Inverter," *IEEE Trans. Ind. Appl.*, vol. 49, no. 2, pp. 922–930, Mar. 2013.
- [14] J. Jiang, S. Peyghami, C. Coates, and F. Blaabjerg, "A Decentralized Reliability-Enhanced Power Sharing Strategy for PV-Based Microgrids," *IEEE Trans. Power Electron.*, vol. 6, no. doi: 10.1109/TPEL.2020.3040991, pp. 7281–7293, 2020.

- [15] S. Peyghami, P. Davari, and F. Blaabjerg, "System-Level Reliability-Oriented Power Sharing Strategy for DC Power Systems," *IEEE Trans. Ind. Appl.*, vol. 55, no. 5, pp. 4865–4875, 2019.
- [16] S. S. Manohar, A. Sahoo, A. Subramaniam, and S. K. Panda, "Condition Monitoring of Power Electronic Converters in Power Plants - A Review," *2017 20th Int. Conf. Electr. Mach. Syst. ICEMS 2017*, 2017.
- [17] M. T. Fard, W. A. Khan, J. He, N. Weise, and M. Abarzadeh, "Fast Online Diagnosis of Open-Circuit Switching Faults in Flying Capacitor Multilevel Inverters," *Chinese J. Electr. Eng.*, vol. 6, no. 4, pp. 53–62, 2020.
- [18] S. Mollov and F. Blaabjerg, "Condition and Health Monitoring in Power Electronics," *CIPS 2018 - 10th Int. Conf. Integr. Power Electron. Syst.*, pp. 61–68, 2018.
- [19] V. Raveendran, M. Andresen, and M. Liserre, "Improving Onboard Converter Reliability For More Electric Aircraft With Lifetime-Based Control," *IEEE Trans. Ind. Electron.*, vol. 66, no. 7, pp. 5787–5796, 2019.
- [20] I. U. Nutkani, P. C. Loh, and F. Blaabjerg, "Droop Scheme with Consideration of Operating Costs," *IEEE Trans. Power Electron.*, vol. 29, no. 3, pp. 1047–1052, 2014.
- [21] S. Peyghami and F. Blaabjerg, "Reliability / Cost-Based Power Routing InPower Electronic-Based Power Systems," in *IEEE ECCE*, 2021, pp. 789–795.
- [22] P. D. Reigosa, H. Wang, Y. Yang, and F. Blaabjerg, "Prediction of Bond Wire Fatigue of IGBTs in a PV Inverter under a Long-Term Operation," *IEEE Trans. Power Electron.*, vol. 31, no. 10, pp. 3052–3059, Mar. 2016.
- [23] D. Reigosa, F. Briz, C. Blanco, P. Garcia, and J. M. Guerrero, "Active Islanding Detection Using High Frequency Signal Injection," in *2011 IEEE Energy Conversion Congress and Exposition*, 2011, pp. 2183–2190.
- [24] D. Zhou, H. Wang, and F. Blaabjerg, "Mission Profile Based System-Level Reliability Analysis of DC/DC Converters for a Backup Power Application," *IEEE Trans. Power Electron.*, vol. 33, no. 9, pp. 8030–8039, 2018.
- [25] J. Falck, C. Felgemacher, A. Rojko, M. Liserre, and P. Zacharias, "Reliability of Power Electronic Systems: An Industry Perspective," *IEEE Ind. Electron. Mag.*, vol. 12, no. 2, pp. 24–35, Jun. 2018.
- [26] R. Bayerer, T. Herrmann, T. Licht, J. Lutz, and M. Feller, "Model for Power Cycling Lifetime of IGBT Modules - Various Factors Influencing Lifetime," in *Proc. IEEE CIPS*, 2008, pp. 1–6.
- [27] "Technical Information IGBT Modules Use of Power Cycling Curves for IGBT 4," Germany, 2012.
- [28] A. Albertsen, "Electrolytic Capacitor Lifetime Estimation," *JIANGHAI Eur. Electron. COMPONENTS GmbH*, pp. 1–13, 2010.
- [29] L. Wenyuan and W. Li, "Risk Assessment of Power Systems: Models, Methods, and Applications," Second Edi. New Jersey: John Wiley & Sons, 2014.
- [30] S. Peyghami, F. Blaabjerg, and P. Palensky, "Incorporating Power Electronic Converters Reliability into Modern Power System Reliability Analysis," *IEEE J. Emerg. Sel. Top. Power Electron.*, vol. 9, no. 2, pp. 1668–1681, 2021.
- [31] S. Peyghami, Z. Wang, and F. Blaabjerg, "A Guideline for Reliability Prediction in Power Electronic Converters," *IEEE Trans. Power Electron.*, vol. 35, no. 10, pp. 10958–10968, 2020.
- [32] J. Steinkohl, S. Peyghami, X. Wang, P. Davari, and F. Blaabjerg, "Frequency Security Constrained Control of Power Electronic-Based Generation Systems," *IET Renew. Power Gener.*, vol. 15, no. 10, pp. 2246–2256, 2021.
- [33] Swinand, G. Peter, Natraj, and Ashwini, "The Value of Lost Load (Voll) in European Electricity Markets: Uses, Methodologies, Future Directions," *Int. Conf. Eur. Energy Mark. EEM*, vol. 2019-September, 2019.
- [34] H. Manninen, J. Kilter, and M. Landsberg, "Advanced Methodology for Estimation of Value of Lost Load (VOLL) Using Equipment Specific Health Indices," *2019 Electr. Power Qual. Supply Reliab. Conf. 2019 Symp. Electr. Eng. Mechatronics, PQ SEEM 2019*, 2019.
- [35] Longo A, Giaccaria S, T. Bouman, and Efthimiadis T, "Societal Appreciation of Energy Security Volume 1: Value of Lost Load-Households (EE, NL and PT)," *Publ. Off. Eur. Union*, vol. EUR 29512, pp. 1–70, 2018.