



Aalborg Universitet

AALBORG UNIVERSITY
DENMARK

Participatory Ergonomics Intervention with technical Measurements in the Construction Industry

A Cluster Randomized Controlled Trial including development of a new method for measuring physical workload

Petersen, Mikkel Brandt

DOI (link to publication from Publisher):
[10.5278/vbn.phd.med.00110](https://doi.org/10.5278/vbn.phd.med.00110)

Publication date:
2018

Document Version
Publisher's PDF, also known as Version of record

[Link to publication from Aalborg University](#)

Citation for published version (APA):
Petersen, M. B. (2018). *Participatory Ergonomics Intervention with technical Measurements in the Construction Industry: A Cluster Randomized Controlled Trial including development of a new method for measuring physical workload*. Aalborg Universitetsforlag. <https://doi.org/10.5278/vbn.phd.med.00110>

General rights

Copyright and moral rights for the publications made accessible in the public portal are retained by the authors and/or other copyright owners and it is a condition of accessing publications that users recognise and abide by the legal requirements associated with these rights.

- Users may download and print one copy of any publication from the public portal for the purpose of private study or research.
- You may not further distribute the material or use it for any profit-making activity or commercial gain
- You may freely distribute the URL identifying the publication in the public portal -

Take down policy

If you believe that this document breaches copyright please contact us at vbn@aub.aau.dk providing details, and we will remove access to the work immediately and investigate your claim.

**PARTICIPATORY ERGONOMICS INTERVENTION
WITH TECHNICAL MEASUREMENTS IN THE
CONSTRUCTION INDUSTRY: A CLUSTER
RANDOMIZED CONTROLLED TRIAL**

INCLUDING DEVELOPMENT OF A NEW METHOD FOR
MEASURING PHYSICAL WORKLOAD

BY
MIKKEL BRANDT PETERSEN

DISSERTATION SUBMITTED 2018

**PARTICIPATORY ERGONOMICS
INTERVENTION WITH TECHNICAL
MEASUREMENTS IN THE
CONSTRUCTION INDUSTRY:
A CLUSTER RANDOMIZED
CONTROLLED TRIAL**

**INCLUDING DEVELOPMENT OF A NEW METHOD FOR
MEASURING PHYSICAL WORKLOAD**

by

Mikkel Brandt Petersen



AALBORG UNIVERSITY
DENMARK



Dissertation submitted

Dissertation submitted: February 2018

PhD supervisor: Professor, PhD, DSc. Pascal Madeleine
Physical Activity and Human Performance group - SMI,
Department of Health Science and Technology
Aalborg University, Denmark

Project PhD supervisor: Professor, PhD, Lars L. Andersen
National Research Centre for the Working Environment
and Physical Activity and Human Performance group -
SMI, Department of Health Science and Technology
Aalborg University, Denmark

PhD committee: Associate Professor Ryan Godsk Larsen
Aalborg University, Denmark

Professor, ph.d. Bo Veiersted
Statens Arbeidsmiljøinstitutt, Norway

Professor Allard van der Beek
VU University Medical Center, The Netherlands

PhD Series: Faculty of Medicine, Aalborg University

Department: Department of Health Science and Technology

ISSN (online): 2246-1302
ISBN (online): 978-87-7210-158-3

Published by:
Aalborg University Press
Langagervej 2
DK – 9220 Aalborg Ø
Phone: +45 99407140
aauf@forlag.aau.dk
forlag.aau.dk

© Copyright: Mikkel Brandt Petersen

Printed in Denmark by Rosendahls, 2018



CV

Mikkel Brandt Petersen (MBP) received his Bachelor degree in 2009 and Master degree in sports science in 2011, both from University of Copenhagen, Denmark. MBP has been working as a clinical research assistant at the Gait Analysis Laboratory at Hvidovre University Hospital, Denmark from 2011-2012, and after that he worked as a scientific assistant at The National Research Centre for the Working Environment until the start of this PhD-project in 2014.

MBP received a grant from the Independent Research Fund Denmark before being enrolled as a PhD-student at the doctoral school of the Faculty of Medicine at Aalborg University. The PhD-project is a cooperation between The National Research Centre for The Working Environment and Aalborg University under supervision from Professor Lars L. Andersen and Professor Pascal Madeleine. During his PhD MBP has given an oral presentation at the Ninth International Scientific Conference on the Prevention of Work-Related Musculoskeletal Disorders (PREMUS, 2016, Toronto, Canada) and a poster presentation at the fifth International Conference on Ambulatory Monitoring of Physical Activity and Movement (ICAMPAM, 2017, Washington, D.C., USA).

PREFACE

This PhD-project was performed in cooperation between The National Research Centre for the Working Environment (NFA), Copenhagen, Denmark and Physical Activity and Human Performance group - SMI, Department of Health Science and Technology, Aalborg University (AAU), Denmark. Supervisors are Professor Pascal Madeleine (AAU) and Professor Lars L. Andersen (NFA and AAU).

The thesis consists of four scientific papers; one protocol, two methods and one intervention study.

The studies are approved by the local ethics committee of Frederiksberg and Copenhagen (H-3-2010-062) and the North Denmark Region Committee on Health Research (N-20160023). The project is registered at ClinicalTrial.gov (NCT02498197) and the Danish Data Protection Agency (215-57-0074).

The enrolment of participants was conducted in accordance with the Declaration of Helsinki, and the reporting followed the CONSORT, SPIRIT and GRRAS guidelines.

The PhD-project was supported by funding from The Danish Council for Independent Research (DFF – 4092-00320, main applicant: Mikkel Brandt Petersen).

A handwritten signature in black ink, appearing to read 'Mikkel Brandt Petersen', with a stylized, cursive script.

Mikkel Brandt Petersen

Copenhagen, January 2018

SUMMARY

Work-related musculoskeletal disorders (WMSD) are among the most prevalent health problems in the industrial countries and have extensive consequences for individuals and society in terms of work disability and sickness absence. Worldwide, low back pain causes more disability than any other condition. Heavy lifting, working in awkward postures, pushing and pulling and manual material handling – which frequently occur during construction work - are associated with increased risk of developing WMSD. Recent data from the Danish Work Environment & Health questionnaire study (AH 2016) show that construction workers have a higher degree of; heavy lifting, pushing and pulling, and work with back rotation or forward bending than the general working population. The number of high-quality intervention studies aiming at reducing the workload in the construction industry is scarce, and the methods for evaluating workload have often been based on self-reports. Technological development has made it possible to obtain technical measurements during full working days by using surface electromyography (sEMG), kinematics (IMU), heart rate and video recordings. However, these measurements have not previously been used simultaneously and in a synchronized manner to detect events of excessive workload during a full day of construction work. While technical measurements are important for achieving good measurements of exposure, making actual changes at the workplaces in the construction industry can be difficult. Participant involvement in interventions has previously shown promising results in certain job groups and may help fit the intervention to the context, culture, as well as the psychosocial and organizational conditions on the working site. However, whether participatory ergonomics can reduce the physical workload in the construction industry is unknown. The overall aim of this PhD-thesis was to investigate whether a participatory ergonomics intervention with technical measurements consisting of IMU, sEMG, heart rate and video recordings of excessive physical workload can reduce the number of events with excessive physical workload during a working day in the construction industry. A Study protocol that describe the purpose and methods planned to be used in the intervention was published (Study I). Two methodological studies (Study II and III) were conducted with the purpose of developing a reliable and accurate method to detect events of excessive physical workload during construction work. In Study II the inter-day reliability of sEMG of the back and neck muscles was tested during standardized lifting situations, which showed moderate to almost perfect reliability ($ICC_{3,k}$) for 89% and 73% of the lifting situations, for absolute and normalized values, respectively. In Study III the accuracy of detecting high or low-risk lifting during standardized lifting situations were tested and showed accuracy up to 78.1%. Based on the results from Study II and III a cluster randomized controlled trial with technical measurements, i.e. sEMG, IMU, heart rate, and video recordings, obtained simultaneously at baseline,

three and six months follow-up, was conducted in the Danish construction industry (Study IV). The sEMG and IMU were used to detect events of excessive physical workload. The video recordings showing excessive physical workload for the construction gang in question were used in a participatory ergonomics intervention involving construction workers and managers. This intervention consisted of three workshops over a three month period. During the workshops several solutions to decrease the physical workload were proposed. The results of the intervention did not show an effect on the number of events of excessive physical workload. However, secondary outcome (questionnaires) showed a decrease in general fatigue after a typical working day from baseline to second follow-up as well as increased influence of own work from baseline to first follow-up, in the intervention group compared with the control group. Altogether, this PhD-thesis demonstrates a new reliable method for detecting events of excessive physical workload during laboratory settings. The thesis demonstrated that it is possible to use the method for event detection in a field environment despite a lack of decrease in the number of events with excessive physical workload.

DANSK RESUME (DANISH SUMMARY)

Arbejdsrelateret muskel- og skeletbesvær (WMSD) er et af de mest udbredte sundhedsproblemer i de industrielle lande og har store konsekvenser for det enkelte individ samt for samfundet i form af blandt andet nedsat arbejdsevne og sygefravær. På verdensplan er smerter i lænderyggen den hyppigste årsag til nedsat arbejdsevne. Tunge løft, dårlige arbejdsstillinger, træk og skub og manuel håndtering af materiel forekommer ofte i bygningsarbejde og indebærer en øget risiko for at udvikle WMSD. Den seneste udgave af den danske undersøgelse ”Arbejdsmiljø og Helbred (AH 2016)” viser, at bygningsarbejdere, sammenlignet med den generelle arbejdsstyrke, i højere grad oplever tunge løft, træk og skub og arbejde med vredet eller foroverbøjet ryg i løbet af en arbejdsdag. Udvalget af studier af høj kvalitet med det formål at reducere arbejdsbelastningen i byggebranchen er sparsomt og ofte baseret på spørgeskemaer. Den teknologiske udvikling har gjort det muligt at foretage tekniske målinger over en hel arbejdsdag ved at anvende af electromyografi (sEMG), kinematik (IMU), hjertefrekvens og videoptagelser. Disse tekniske målemetoder har ikke tidligere været anvendt simultant og synkront til at detektere arbejdsituationer med uhensigtsmæssig høj arbejdsbelastning under bygningsarbejde, men de kan være et middel til troværdige målinger af den fysiske belastning. Dog kan det trods pålidelige målinger være svært at skabe faktiske ændringer i byggebranchen. Interventioner med deltagerinvolvering har tidligere vist lovende resultater, og deltagerinvolvering kan muligvis være medvirkende til at tilpasse indsatsen til den enkelte virksomheds kontekst og kultur såvel som de psykosociale og organisatoriske rammer på arbejdspladsen. Det er uvist, om en deltagerinvolverende ergonomisk indsats kan reducere den fysiske arbejdsbelastning i byggebranchen. Formålet med denne Ph.d.-afhandling har været at undersøge, om deltagerinvolverende ergonomisk intervention med tekniske målinger bestående af sEMG, IMU, hjertefrekvens og videoptagelser af den fysiske arbejdsbelastning kan reducere antallet af situationer med uhensigtsmæssig høj arbejdsbelastning under en arbejdsdag i byggebranchen. Der er publiceret en protokolartikel, som beskriver formål og de metoder, der var planlagt at anvende i interventionsstudiet (studie I). Derudover blev der udført to metodestudier (studie II og studie III), som havde til formål at udvikle pålidelige og præcise metoder til at detektere situationer med uhensigtsmæssig høj arbejdsbelastning under bygningsarbejde. I studie II blev inter-day pålideligheden af sEMG fra ryg- og skuldermuskler testet under standardiserede løftesituationer og viste en moderat til næsten perfekt pålidelighed i form af ICC_{3,K} for henholdsvis 89 % og 73 % af løftesituationerne for absolutte og normaliserede værdier. I studie III blev præcisionen af detektering af høj- eller lavrisiko løft under standardiserede løftesituationer testet og viste en præcision på op til 78,1 %. Et cluster randomiseret kontrolleret studie blev udført i den danske byggebranche baseret på resultaterne fra studie II og III ved brug af synkroniserede tekniske målemetoder, dvs. sEMG, IMU,

hjerterefrekvens og videooptagelser ved baseline samt ved tre og seks måneders opfølgning (Studie IV). sEMG og IMU blev brugt til at detektere en uhensigtsmæssig høj arbejdsbelastning. Mens videooptagelserne afslørede, hvilke arbejdssituationer der fremkaldte den pågældende uhensigtsmæssige arbejdsbelastning. Udvalgte optagelser blev efterfølgende anvendt i en deltagerinvolverende ergonomisk intervention for bygningsarbejdere og deres formænd. Interventionen bestod af tre workshops over en periode på tre måneder. Under workshopforløbet blev der foreslået adskillige løsninger til at mindske den fysiske arbejdsbelastning. Resultaterne af interventionen viste ingen effekt på antallet af situationer med uhensigtsmæssig høj arbejdsbelastning. Sekundære outcome (spørgeskemaer) viste et fald i generel træthed i kroppen efter en typisk arbejdsdag fra baseline til anden follow-up samt en øget indflydelse på eget arbejde fra baseline til første follow-up i interventionsgruppen sammenlignet med kontrolgruppen. Alt i alt demonstrerer denne ph.d.-afhandling en ny og pålidelig metode til at detektere situationer med uhensigtsmæssig høj arbejdsbelastning under laboratorieforhold. Afhandlingen viser desuden, at det er muligt at anvende denne metode til at detektere situationer med uhensigtsmæssig høj arbejdsbelastning i et feltstudie, til trods for at interventionen ikke viste et fald i antallet af situationer med uhensigtsmæssig høj arbejdsbelastning.

ACKNOWLEDGEMENTS

I would like to acknowledge the generous economical support of the present project granted by The Danish Council for Independent Research (Grant number: DFF – 4092-00320). The Danish Construction Association and 3F also deserve a great acknowledgement for your help with recruitment and for covering the lost of earning for the participants in the project. Without this, the project could not have been carried out. Furthermore, I would like to thank the Oticon foundation and Otto Mønsted foundation for travel grants that made it possible to participate in international scientific conferences.

Many people have supported me throughout the last three years.

First, I would like to thank my two supervisors. Pascal Madeleine from AAU, for your involvement and for always taking your time discussing the project and for being critical, which have increased the level of the project. Lars L. Andersen from NFA for your support and guidance. You have been an excellent sounding board in challenging periods. Thank you for pushing me into research, without this I had probably not ended up as a PhD-student.

I also owe a huge thank to:

Afshin Samani from AAU, who has put an extraordinary amount of work into writing the programs for the event detection in the project. I deeply appreciate your big effort.

Klaus Hansen from NFA for your flexibility and for getting up in the middle of the night to go testing. I am grateful for the energy you put into the project during both test periods and in the development of the test equipment.

Sebastian Skals and Jonas Vinstrup for also helping out in test periods.

The research group and good colleagues and friends from NFA, especially Jeppe Ajslev, Emil Sundstrup and Markus Due Jakobsen. Jeppe for your cooperation during the workshops, our many fruitful discussions and lots of good laughs. Markus for saving me several times with technical help, support and for helping out with data collection. Emil for help during data collection and for always taking your time for discussions.

Peter Hansen, Stefan Jakobsen and Jørgen Skotte from NFA for great technical support during the development of the test equipment.

All the consultants from Bambus, for your valuable critical comments and your help during the recruitment of construction companies.

The construction companies and all the participants at the construction sites.

Last but not least, my family Mette and Mynte for great flexibility in the family life that made it possible to have all the test days away from home. And for constantly reminding me that playing with Lego, drawing, and jumping, always is more important than research.

LIST OF STUDIES

The studies included in the thesis are provided in the appendices section.

STUDY I

Brandt, M., Madeleine, P., Ajslev, J.Z.N., Jakobsen, M.D., Samani, A., Sundstrup, E., Kines, P., and Andersen, L.L. (2015). *Participatory intervention with objectively measured physical risk factors for musculoskeletal disorders in the construction industry: study protocol for a cluster randomized controlled trial*. BMC Musculoskelet. Disord. (1)

STUDY II

Brandt M, Andersen LL, Samani A, Jakobsen MD, Madeleine P. (2017). *Inter-day reliability of surface electromyography recordings of the lumbar part of erector spinae longissimus and trapezius descendens during box lifting*. BMC Musculoskelet Disord. (2)

STUDY III

Brandt M, Madeleine P, Samani A, Jakobsen MD, Skals S, Vinstrup J, Andersen LL. (2017). *Accuracy of identification of low or high risk lifting during standardized lifting situations*. Ergonomics. (3)

STUDY IV

Brandt M, Madeleine P, Samani A, Ajslev JZN, Jakobsen MD, Sundstrup E, Andersen LL. *Effects of a participatory ergonomics intervention with technical measurements of physical workload in the construction industry: A cluster randomized controlled trial*. (4) Submitted, January 2018.

ABBREVIATIONS

sEMG	Surface electromyography
MVC	Maximal voluntary contraction
LDA	Linear discriminant analysis
WMSD	Work related musculoskeletal disorders
VAS	Visual analogue scale
IMU	Inertial measurement units
ICC	Intra class correlation coefficient
SEM	Standard error of measurement
MDC	Minimal detectable change

TABLE OF CONTENTS

Chapter 1. INTRODUCTION.....	23
1.1. Appetiser	23
1.2. Work-related musculoskeletal disorders	23
1.3. Risk factors for work-related musculoskeletal disorders	24
1.4. Work-related musculoskeletal disorders in the construction industry	24
1.5. How to measure physical workload	26
1.5.1. Self-reporting and visual observations	26
1.5.2. Technical measurements	26
1.6. Development of a new method for measuring physical workload	28
1.7. Participatory ergonomics	28
1.8. Aims and hypotheses.....	29
Chapter 2. METHODS	31
2.1. Study overview	31
2.2. Ethics.....	34
2.3. Recruitment.....	35
2.4. Compensation for lost earnings.....	36
2.5. Technical measurements	36
2.5.1. Kinematics	36
2.5.2. Surface electromyography.....	36
2.5.3. Video recordings	37
2.5.4. Heart rate monitoring	38
2.5.5. Synchronization of technical measurements	38
2.6. Event detection.....	39
2.7. Box lifting	40
2.8. Maximal voluntary contraction	40
2.8.1. Strength measurements	40
2.9. Questionnaires.....	41
2.10. Randomization	41
2.11. Intervention	42

2.11.1. Intervention group - workshops	42
2.11.2. Control group	43
2.12. Statistics	44
Chapter 3. RESULTS	45
3.1. Reliability of surface Electromyography (Study II)	45
3.2. Accuracy of identification of low or high risk lifting situations (Study III)..	45
3.3. Effects of a participatory ergonomics intervention with technical measurements of physical workload (Study IV)	46
Chapter 4. DISCUSSION	51
4.1. Reliability of surface Electromyography (Study II)	51
4.2. Accuracy of identification of low or high risk lifting situations (Study III)..	52
4.3. Effects of a participatory ergonomics intervention with technical measurements of physical workload (Study I and IV)	53
4.4. Challenges when research meets practice	57
4.4.1. Inertial measurement unit drift	57
4.4.2. Recruitment	57
4.4.3. Surface electromyography drift	58
4.4.4. Construction work in general	58
4.4.5. Strengths and limitations	58
Chapter 5. CONCLUSIONS	61
Chapter 6. PERSPECTIVES	63
Chapter 7. THESIS AT A GLANCE.....	65
Chapter 8. REFERENCES.....	67
Chapter 9. APPENDICES	81

FIGURES AND TABLES

Figures

Figure 1: Data from Work Environment and Health 2016 (AH 2016)	25
Figure 2: Study overview.	31
Figure 3: Detailed timeline of the inter-day reliability of sEMG (Study II)	32
Figure 4: Detailed timeline of the accuracy study (Study III)..	33
Figure 5: Timeline of the intervention study (Study IV)..	33
Figure 6: Illustration of placement of sEMG electrodes	37
Figure 7: Illustration of working tasks during the project.	38
Figure 8: Description of the synchronization process	39
Figure 9: Illustration of MVCs including strength measurements	41
Figure 10: Pictures from a workshop	43
Figure 11: Force measured during the MVC	49
Figure 12: Bland-Altman plots of the intra-day reliability of sEMG.	49
Figure 13: Bland-Altman plots of the inter-day reliability of sEMG.	50

Tables

Table 1: Overview of the methods used in the studies (Study I-IV)..	34
Table 2: Anthropometrics of the participants in the studies	35
Table 3: Explorative analyses of events of excessive physical workload	48

CHAPTER 1. INTRODUCTION

The following chapter introduces the scope and background of the present thesis. The overall aim and hypotheses of the thesis are also presented.

1.1. APPETISER

These years extensive changes appear in the Danish labour market. The pension age is increasing, and workers born before 1967 have to stay in the labour market until the age of 68 (5). This trend is similar in most European countries (6). Consequently, the part of the labour force categorized as elderly is increasing and fewer young people are replacing the older in physical manual work (6). This development constitutes a paradox for construction workers in Denmark, as they have to manage a continuously high physical workload (7) while their physical capabilities naturally decreases with age (8). This scenario underlines the need for interventions trying to decrease the physical workload for workers in the construction industry.

Hence, the present PhD-thesis study the possibility of reducing the excessive physical workload during construction work by using participatory ergonomics with technical measurements of physical workload.

1.2. WORK-RELATED MUSCULOSKELETAL DISORDERS

Work-related musculoskeletal disorders (WMSD) embrace a wide range of both non-specific pain disorders without known cause as well as inflammatory and degenerative conditions that affect muscles, tendons, joints, peripheral nerves and blood vessels (9,10). WMSD typically affect job groups with a high degree of physical workload, e.g. workers in the construction industry (11–13).

WMSD are among the most prevalent health problems in the industrial countries (14,15,12,16–21). The consequences of WMSD are extensive for the individual in terms of reduced overall health, work disability and increased use of analgesics, and it imposes a socioeconomic burden because of an increased use of the health care system, sickness absence and loss of productivity (9,13,22–27). Especially, low back pain and neck-shoulder pain are highly prevalent among the working population and causes many years with disability (14,28–30). The Global Burden of Disease study shows that low back pain causes more disability worldwide than any other health-

related condition (31,32). In the extreme, WMSD can lead to disability pension (33,34) or early retirement from the labour market (35,36). Prevention should be prioritized, as pain is often recurring (37–39).

1.3. RISK FACTORS FOR WORK-RELATED MUSCULOSKETAL DISORDERS

The literature defines several risk factors for developing WMSD. Heavy and strenuous physical work is the most influential risk factor in the working environment (40–42), and in particular heavy lifting (40,42), working in awkward postures (8,41,43), pushing and pulling (44), and manual material handling (43,45) are found to be related to the development of WMSD. Associations between low back pain, and working with bended or rotated back have additionally been pointed out (46). Furthermore, working with arms above shoulder level is associated with increased shoulder complaints, which are a predictor of WMSD (45,47).

1.4. WORK-RELATED MUSCULOSKELETAL DISORDERS IN THE CONSTRUCTION INDUSTRY

Heavy physical work is a distinct part of the construction industry, where several work tasks include a combination of the abovementioned risk factors for WMSD (41,42).

In the most recent version of the Danish survey “Work Environment and Health” (7), construction workers (n=370) state to have a higher degree of sickness absence caused by work, pain intensity, heavy lifting, pushing and pulling, and work with back rotation or forward bending compared to a large sample of the Danish working population (n~30.000) (Figure 1). In regard to the level of physical work, the construction workers perceived their work as being 6.4 on a scale from 0-10 where 0 is “not hard” and 10 is “maximal hard”. On the contrary, the general working population of Denmark perceived their work to be 3.6 on this scale (7).

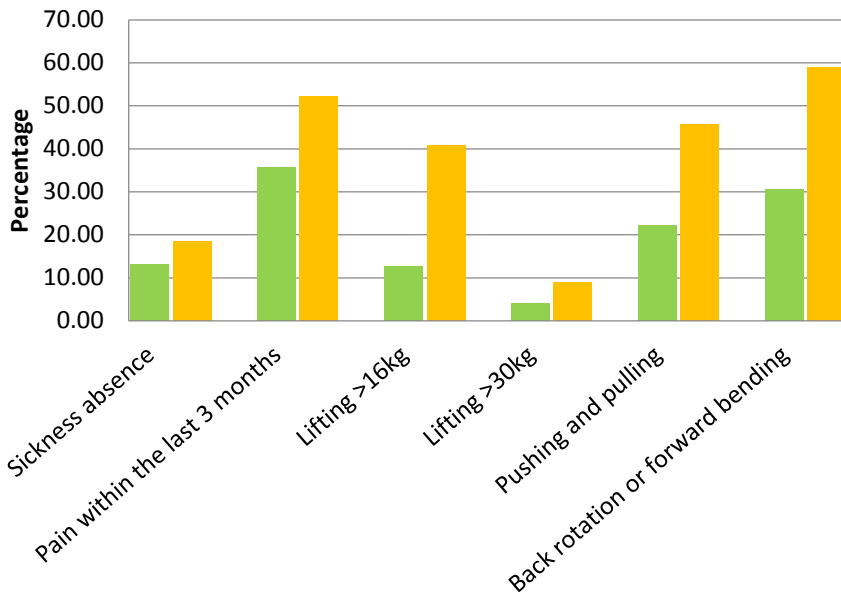

Figure 1: Data from Work Environment and Health 2016 (AH 2016) (7). The figure compares numbers from construction workers with the total population of the survey. Green=Total population of the survey, Yellow=construction workers.

Other studies have shown that blue-collar workers have a higher risk of developing low back pain compared with white-collar workers (48). A high biomechanical burden leads to increased risk for disability later in life (49), and WMSD are found to be a predictor for occupational disability in the construction industry (50).

In a qualitative study among early retired construction workers half of the respondents point out poor health as an important reason for their early retirement (51). Furthermore, an epidemiological study has shown that heavy physical work is a predictor for disability pension among 325.549 Swedish construction workers (52).

Because it is expected that everybody will have longer working lives in the years to come and the statutory pension age is increasing in Denmark and other European countries, managing WMSD in the construction industry will likely be more complicated in the coming years. As stated earlier, this potential development can have huge consequences for both individuals and society. Therefore, to compensate for the increased years on the labour market, there is a need to reduce the physical workload in the construction industry.

1.5. HOW TO MEASURE PHYSICAL WORKLOAD

Valid and reliable measurement methods are a cornerstone of high quality research in working environment research concerning physical workload. Physical workload in construction work can be measured in different ways, and all methods have their pros and cons.

The following sections will describe the methods that have previously been used to measure physical workload.

1.5.1. SELF-REPORTING AND VISUAL OBSERVATIONS

Self-reported measurements (53) have often been used in studies of physical exposure. However, this method can be inaccurate or have poor validity (54) and can be influenced by e.g. muscle pain (55), which introduces the risk of misclassification (53,56,57).

Visual observation is another method of determining physical exposure during work. Despite the availability of several methods for visual observation, these are all based on subjective observer ratings, and the observer faces difficulty in observing more than one worker at a time. Thus, precise estimation of physical workload obtained during work is difficult by using visual observations (54,55), and the method is often not as cost-effective as technical measurements (58).

1.5.2. TECHNICAL MEASUREMENTS

Throughout the recent years the development in technology has made it possible to provide information about the physical workload during field studies over an entire working day (59–62).

Kinematics

Kinematics is a method for studying postures of e.g. the human body, which can be measured cost efficient with inertial measurement units (IMU) (58). Kinematics measured with IMU has been used in several field studies to detect the degree of physical activity (63), forward bending (62,64), trunk bending and rotation (65), sitting and standing (66) or upper arm postural exposure amplitudes, frequencies and durations (67), and for detecting unhealthy postures and movements in a laboratory setting (68). The use of IMU has shown high sensitivity and specificity in detecting various types of physical activity (69). Furthermore, IMU have shown valid estimates of arm and upper body inclination in simulated work tasks (70,71). Even though kinematics measured with IMU is a valid and widely used method to detect positions of the body it does not contain direct information about the load the workers are exposed to.

Surface electromyography

Surface electromyography (sEMG) can on the contrary give insight into the physical load that a worker is exposed to. sEMG is a method for recording electrical activity running from the nervous system to the skeletal muscles. The muscular activity signals are formed by physiological variations in the state of muscle fibres (72,73). In other words, sEMG can provide information about the myoelectrical activity of skeletal muscles, e.g. during a working day.

Jakobsen et al. (2014) measured sEMG on blue-collar workers with manual lifting tasks from the shoulders and lower back to investigate associations between perceived exertion and muscular load during a full working day (59). Hanvold et al. (2013) measured sEMG from the upper trapezius muscles among young adults during a full working day to determine sustained trapezius muscle activity (74). Furthermore, Lidegaard et al. (2013) measured sEMG from splenius and upper trapezius during a full working day to study the acute and longitudinal effects of resistance training on occupational muscle activity in office workers with chronic pain (75). While sEMG unlike IMU can measure the workload, this method does not provide information about which position the body is in while the muscular activity is measured.

Video recordings

Video recordings are considered being cost efficient in observing posture (76), and have been used in ergonomics studies to identify risks and ergonomic discomfort among truck drivers (77), and differences in work technique among cashiers (78). On the contrary, video recordings are subject to subjective assessments when analysing the work tasks (79), and it is time consuming to go through the video recordings.

Separately, the above technical measurements have limitations, but a combination might compensate for this. The use of these methods simultaneously and synchronized has potential to provide detailed information about the work tasks that expose the workers to excessive physical workload.

Given that kinematics measured with IMU and sEMG can provide information about position of the body and intensity of muscular activity, respectively, the video recording can reveal the specific work task.

However, no studies have used the sEMG, kinematics and video recordings simultaneously and synchronized to detect events with excessive physical workload based only on technical measurements during construction work.

1.6. DEVELOPMENT OF A NEW METHOD FOR MEASURING PHYSICAL WORKLOAD

The ability of detecting events of excessive physical workload from technical measurements highly depends on valid and reliable measurement methods. The first step in developing such method was to test the reliability of sEMG across days. For that purpose relative and absolute reliability addressed by the intra class correlation coefficient (ICC) and standard error of measurement (SEM) and minimal detectable change (MDC), respectively (80). The reliability of sEMG obtained during box lifting situations following a standardized lifting protocol has not been fully covered. Nevertheless, previous studies show encouraging results for the low back (81,82) and shoulder muscles (83–85), during different test positions, respectively (see Study II, table 1). The second step was to develop and test the ability of the method to detect events of excessive physical workload based on sEMG and kinematic measurements in a laboratory setting. In the third and final step, the method was used in the field to work tasks of excessive physical workload of construction workers. The video recordings were afterwards used in a participatory ergonomics intervention.

1.7. PARTICIPATORY ERGONOMICS

Participatory ergonomics programs maximise the involvement of workers in the process and decision making by acknowledging that the individual worker is the true expert on his/hers work (86,87).

Participant involvement in workplace interventions is recommended by several researchers, since it will increase the chance for a successful outcome and sustainable implementation (88–90). Following this recommendation, participatory involvement fits the intervention to the context, culture, as well as the psychosocial and organizational conditions at the working site. Further, the employees feel ownership of the intervention and support it to a greater extent. The European Agency for Safety and Health at Work also recommends employees to be involved in the processes at the working site as a way to motivate workers and help the employer identify the problems and find the best solutions (91).

Interventions that involve the workers and tailor the work to the employees' capacity, have shown to support the return to work after sickness absence due to back pain (87). Likewise, it has also been reported that the physical workload can be reduced when technical assistive devices are included as part of a participatory intervention (92). A participatory ergonomics intervention among cleaners has shown that the cardiovascular and musculoskeletal load can be reduced (60). The outcome was a decrease in physical workload and a more varied muscular activity,

which is considered to be preventive to musculoskeletal pain (10). However, it is unknown if participatory ergonomics can reduce the physical workload in the construction industry where the work is constantly changing in terms of work tasks and conditions at the working site.

The number of high quality intervention studies aiming at reducing WMSD in the construction industry is scarce, and there is a need for high quality studies to fill this gap (93). This statement and the above mentioned reasons emphasize the importance of the present PhD-thesis.

1.8. AIMS AND HYPOTHESES

The overall aim of this PhD-thesis was to investigate whether a participatory ergonomics intervention with technical measurements consisting of IMU, surface electromyography (sEMG), heart rate and video recordings of excessive physical workload can reduce the number of events with excessive physical workload during a working day in the construction industry (Study protocol, Study I, and intervention, Study IV).

To ensure reliable measurement methods for Study IV, the second aim was to develop a reliable and accurate method to detect events of excessive physical workload, based on technical measurements during manual lifting (laboratory studies, Study II and III).

To provide a full picture of the working environment conditions, the technical measurements of the physical workload were combined with surveys on psychosocial as well as organizational conditions.

It was hypothesized that detection of events of excessive physical workload could be performed based on technical measurements.

Further, it was hypothesized that a participatory ergonomics intervention involving both managers and workers would lead to a reduction in the events of excessive physical workload.

CHAPTER 2. METHODS

This chapter briefly outlines the design and methods used in the present PhD-thesis. For a more thorough and detailed description see Appendix I-IV (Study I-IV).

2.1. STUDY OVERVIEW

This thesis consists of a study protocol (Study I) and two methodological studies conducted in laboratory environment (Study II and III) leading to the intervention study performed in a field environment (Study IV). A short overview of the studies is provided in the following sections, in Figure 2, and in Chapter 7, Thesis at a glance.

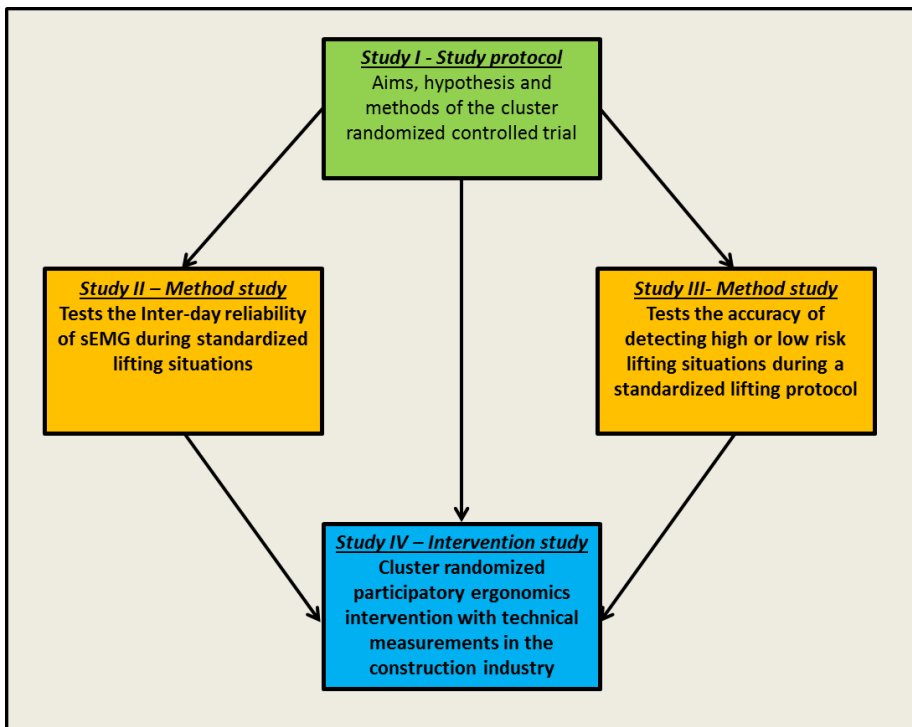

Figure 2: Study overview.

The study protocol (Study I) contains information about design of the intervention and power calculation, and was published before enrolment of participants for the intervention.

Study II was carried out at Aalborg University and tested the inter-day reliability of sEMG from the shoulders and low back muscles in a laboratory environment during standardized box lifting. During the study, the participants visited the laboratory at two occasions with approximately two weeks in between. A timeline for Study II is outlined in Figure 3.

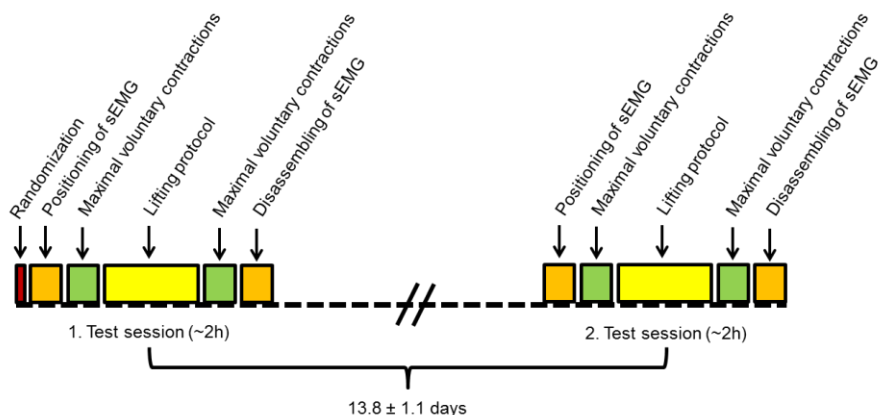

Figure 3: Detailed timeline of the test of the inter-day reliability of sEMG (Study II)

Study III was also a laboratory study and was performed at the National Research Centre for the Working Environment. The purpose of this study was to test the accuracy of identifying low and high risk lifting. During this study, the participants came to the laboratory four times during a day. A timeline for Study III is outlined in Figure 4.

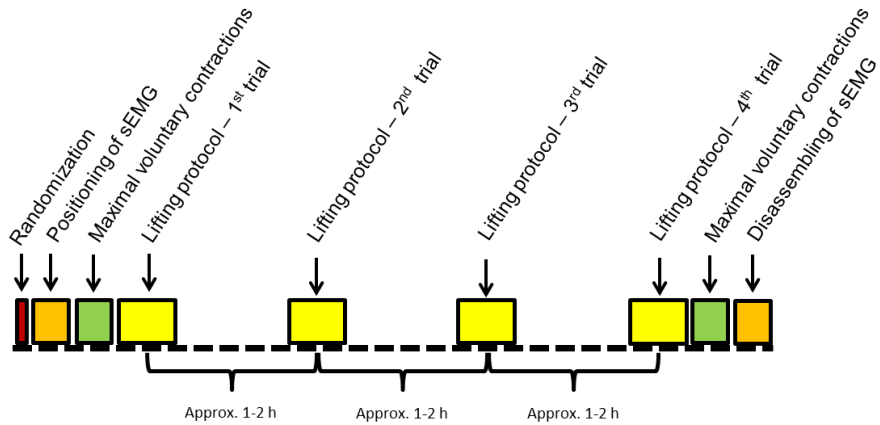

Figure 4: Detailed timeline of the accuracy study (Study III). Figure is adapted from Figure 1 in Study III.

The intervention study (Study IV) is a cluster randomized controlled trial conducted in the Danish construction industry from May 2016 to June 2017. The study consisted of three workshops in a period of approximately three months with technical measurements at baseline, three (First follow-up) and six (Second follow-up) months follow-up, respectively. A timeline of Study IV is outlined in Figure 5.

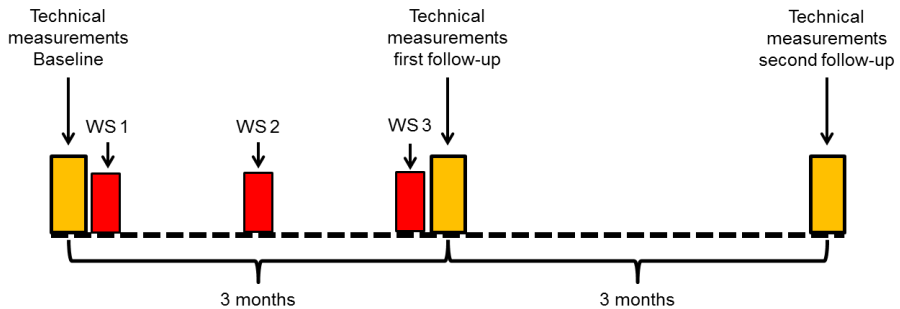

Figure 5: Timeline of the intervention (Study IV), including times for technical measurements. WS=Workshop.

Table 1 presents an overview of the methods used in the four studies, followed by a more detailed description in the following sections.

	Study I	Study II	Study III	Study IV
Study protocol	x			
Laboratory study		x	x	
Field study				x
Randomization		x	x	
Cluster randomization	x			x
sEMG	x	x	x	x
Kinematics	x		x	x
Video recordings	x			x
Heart rate				x
Box lifting / reference lifts	x	x	x	x
Maximal voluntary contraction	x	x	x	x
Strength measurements				x
Event detection			x	x
Participatory Ergonomics	x			x
Questionnaire	x			x

Table 1: Overview of the methods used in the four studies (Study I-IV). Please note that Study I is a study protocol, hence this study contains only descriptions of the methods.

2.2. ETHICS

All participants received oral and written information about the purpose and content of the study, according to the convention of Helsinki. The participants signed their informed consent before being enrolled in the study. To ensure transparency, a study protocol that describes the design of the intervention was published (Study I) and registered at clinicaltrials.gov (NCT02498197). The reporting of the intervention study (Study I and IV) followed the CONSORT-guidelines for cluster randomized trials (94,95) to secure a transparent reporting of the results. The study protocol followed the SPIRIT-guidelines (96,97), and the method studies (Study II and III) followed the GRRAS guidelines for reporting reliability and agreement studies (98). The overall project was approved by the Danish National Ethics Committee on Biomedical Research', the committee of Frederiksberg and Copenhagen, (H-3-2010-062). Study II took place at Aalborg University and was approved by the North Denmark Region Committee on Health Research (N-20160023). The inclusion and exclusion criteria were in general the same for all the studies; for Study II and III, the inclusion criteria were healthy men (18-60 years) without any back or shoulder disorders, heart diseases or hypertension. Moreover, for Study IV, the participants had to work full time in the construction industry and had to read and speak Danish. However, there were no "working age" limit in this study. See Study I-IV for details.

2.3. RECRUITMENT

Study II, III and IV were all performed with different participants. Hence the recruitment was not the same for all three studies. See Table 2 for a description of the study population included in the studies.

	Study II	Study III	Study IV
N	17	25	80
Sex	All male	All male	All male
Age (yr)	28.6 ± 10.0	32.4 ± 6.0	39.4 ± 12.9
Height (cm)	179.4 ± 7.1	182.4 ± 9.2	178.3 ± 6.7
Body mass (kg)	76.4 ± 10.0	79.7 ± 9.5	85.6 ± 14.5
BMI (kg/m²)	23.8 ± 2.7	23.9 ± 2.0	26.9 ± 3.9
Dom hand (R/L)	R=16 / L=1	R=22 / L=3	R=71 / L=9

Table 2: Anthropometrics of the participants in the studies presented as mean ± SD. The data is adapted from table 2 (Study II), table 1 (Study III) and table 1 (Study IV).

The recruitment of participants for Study II is described in details in Study II. In short, the trial was posted on the website: <https://www.forsog.dk/> and the majority of participants were recruited through this site. The remainder were enrolled ad-hoc through written and verbal announcements.

The recruitment of participants for Study III was mainly carried out by sending an e-mail to the male employees of a middle-sized office company. The remainder were enrolled ad-hoc through written and verbal announcements. See Study III for further details.

The enrolment of construction gangs for the intervention study is described in Study IV. To kick off the recruitment, physical meetings were held with The Danish Construction Association and The Safety and Health Preventive Service Bus.

In brief, construction companies were contacted through The Danish Construction Association's list of members. Furthermore, consultants from The Safety and Health Preventive Service Bus contacted construction companies in their network. Moreover, former collaborators were contacted. First, the companies were contacted by e-mail, followed up by a phone call, where they were offered a meeting to inform the employer and the employees about the project. During the recruitment phase, one phone meeting and seven physical meetings were held with construction companies nationwide. Three construction companies were willing to participate in the project, and gave permission to meet with managers and foremen at their

construction sites. A total of 13 meetings were held, which resulted in participation from nine construction sites with a total of 15 construction gangs.

2.4. COMPENSATION FOR LOST EARNINGS

The participants or their employers were compensated with 260dkk/hour for their loss of earnings through their participation in the intervention study (Study IV). The compensation was funded by The Danish Construction Association and the Danish union 3F's "Arbejdsmiljø og Samarbejdsfonden". This funding was crucial for the project, since the recruitment would have been much more difficult without this possibility.

2.5. TECHNICAL MEASUREMENTS

The following paragraphs summarize the technical methods used in the thesis. For a more detailed description, please refer to Study II, III and IV.

2.5.1. KINEMATICS

Small portable IMU (ActiGraph GTX9-Link, ActiGraph, Pensacola, USA) were used to obtain the kinematic measurements in Study III and IV. In Study III, the IMU were placed on the upper (70) and lower back (99) while in Study IV, they were placed on the upper back (70), and one IMU was placed on the thigh for calculation of the number of steps (100). The IMU were calibrated by having the subject standing in neutral position (N-pose) (69). Please see Study III and IV for a more detailed description. Moreover, kinematics were planned to be included in Study II, but due to technical problems with the IMU, the data were discarded, which is described in Chapter 4.4.1.

2.5.2. SURFACE ELECTROMYOGRAPHY

Surface EMG is a fundamental method in this PhD-thesis, and sEMG measurements were obtained in the same way in Study II, III and IV. In short, sEMG was obtained from the shoulder and lower back muscles, i.e. bilateral from trapezius part descendens and the lumbar part of erector spinae and recorded with portable data loggers (Nexus 10, Mind Media, Herten, Netherlands). The placement of the sEMG electrodes (Figure 6) followed the SENIAM recommendations (<http://www.seniam.org/>) and the ISEK standards (<http://www.isek.org/emg-standards/>). See Study I, II, III and IV for a more detailed description of placement

and analyses of sEMG. For all studies, custom made Matlab scripts were used (MathWorks, Natick, MA, USA).



Figure 6: Illustration of the placement of sEMG electrodes.

2.5.3. VIDEO RECORDINGS

In Study IV, video recordings were obtained simultaneously to the sEMG and IMU measurements, which made it possible to see which work tasks the workers were performing. This enabled to link the sEMG activity and IMU measurements with the task performed confirming the detection of events of excessive physical workload. The video cameras (Reveal Media, RS2-X2L, Hampton Wick, Surrey, UK) were shock resistant and had a long recording time regarding battery time and memory capacity (approximately 8 hours). The video cameras had a default security-setting to start a new video file every 40 minute, i.e. a working day was stored in several video files. The video camera was placed in a harness around the chest of the participants (Figure 7).

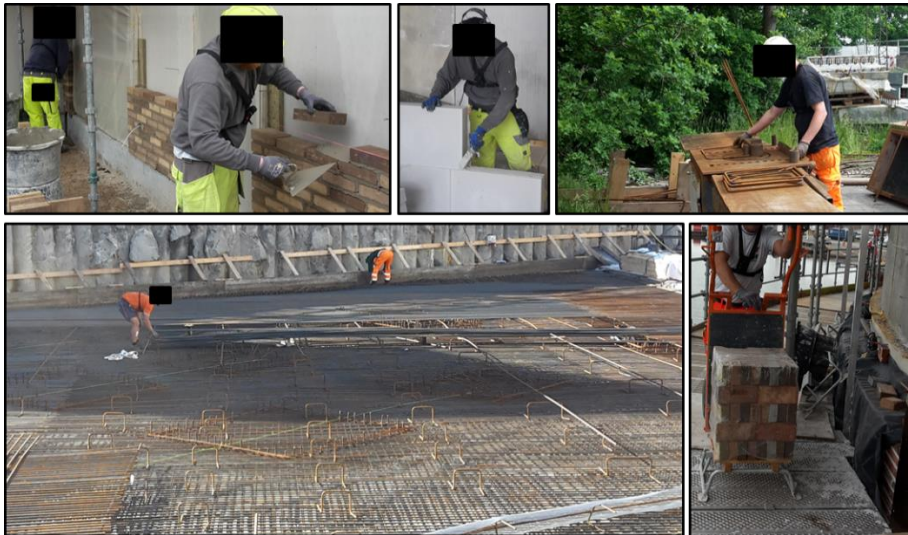

Figure 7: Illustration of work tasks during the project. Top left: Bricklaying, top middle: Masonry of gas concrete, top right: iron bending, bottom left: Iron binding, bottom right: Bricklayers' assistant placing bricks on the scaffold.

2.5.4. HEART RATE MONITORING

Heart rate monitors (Actiheart, CamNtech Ltd, Cambridge, UK) were used in Study IV to measure the participants' cardio vascular load during their working day. The Actiheart devices have proven to be a suitable method for measuring heart rate during work activities (101,102). The heart rate data were used to adjust for a potential difference in the physical workload between the measurement days. Please see Study IV for a detailed description of the heart rate monitoring.

2.5.5. SYNCHRONIZATION OF TECHNICAL MEASUREMENTS

It was essential to collect the data in a synchronized manner, to detect work tasks of excessive physical workload for the construction workers during their working day. A synchronization (or trigger) procedure was performed in Study II, III and IV.

In brief, the synchronization was carried out before the participants arrived at the test site, i.e. laboratory for Study II and III, and a designated room at the construction site in Study IV, the sEMG, IMU and cameras were synchronized using a customized device. This instrument consisted of an A/D-converter, a control unit (National Instruments) connected with a cable to the sEMG data-logger, a rotary solenoid (GDAX 050 X20 B71 24V 100% ED) for the IMU and a flashing diode for

the camera (Figure 8). A signal was sent to the three devices ten times with an interval of 30 seconds between each signal. The same setup was used in all three studies, but in Study II only for the sEMG data-logger, and in Study III only for the sEMG data-logger and the IMU. Please see Study II, III and IV for detailed descriptions.

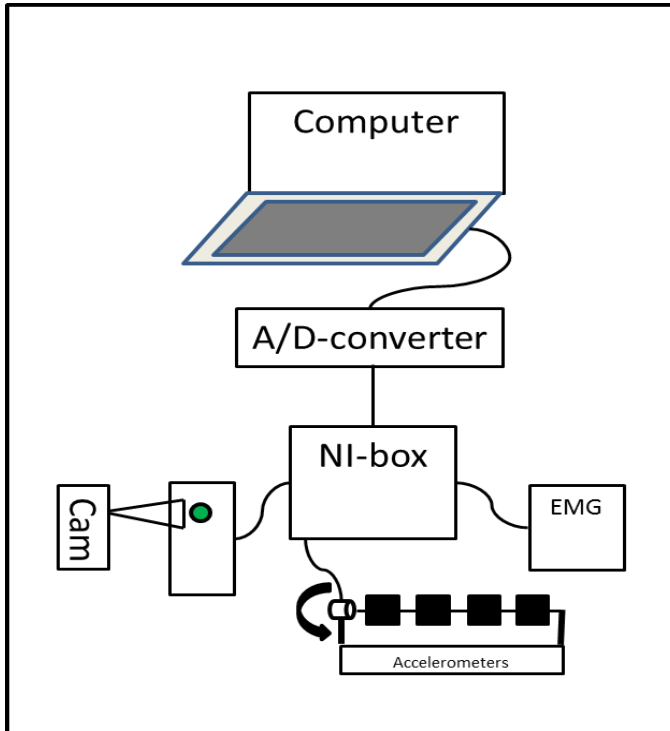

Figure 8: Illustration of the synchronization process.

2.6. EVENT DETECTION

The method for detection of events of excessive physical workload was developed and tested in a laboratory setting in Study III. In Study IV, the method was used in an intervention study. In the intervention study, the primary outcome was the change in events with excessive physical workload, and event detection was based on reference lift consisting of lifting a box of known load. For explorative analyses, the event detection was based on maximal voluntary contractions (MVC). Please see Study III and IV for further details.

2.7. BOX LIFTING

Box lifting was used to test the inter day reliability of sEMG in Study II and to test the classification accuracy in Study III. Furthermore, box lifting was used as reference lift, i.e. to set the cut point of excessive physical workload in Study IV. The same box was used for all box lifting occasions and it was possible to change the weight of the box by adding or removing loads. Detailed descriptions of the lifting protocols are given in Study II, III and IV.

2.8. MAXIMAL VOLUNTARY CONTRACTION

Maximal voluntary contractions (MVC) were performed for the lower back (erector spinae) and shoulder (trapezius) muscles in Study II, III and IV. A detailed description is available in Study II, III and IV.

In short, the MVCs were performed against resistance from the test leader by lying prone in a custom-made apparatus (103) or standing upright with 90 degrees abduction in the shoulders for the lower back and shoulder muscles, respectively. While in Study IV the MVCs were performed, against static resistance from custom-made test equipment in a standing position (Figure 9) (104). The possibility for obtaining strength measurement were the primary reason for not using the same MVC procedure in all studies.

2.8.1. STRENGTH MEASUREMENTS

In Study IV, strength measurements were obtained during the MVCs using a custom-built dynamometer with a strain gauge load cell (KIS-2, 2 KN, Vishay Transducers Systems, Malvern, PA, USA). For the low back, a strap was placed around the upper back, at the level of insertion of the deltoid muscle, and connected to a strain-gauge dynamometer (Figure 9b) (104). For the shoulders, the straps around the participant's wrists were connected to a custom-built wooden plate with two strain gauge dynamometers (Figure 9a). Participants were instructed to exert maximal force by building up force over a few seconds and exert maximally for another few seconds while the test leader provided verbal encouragement. See Study IV for further details.

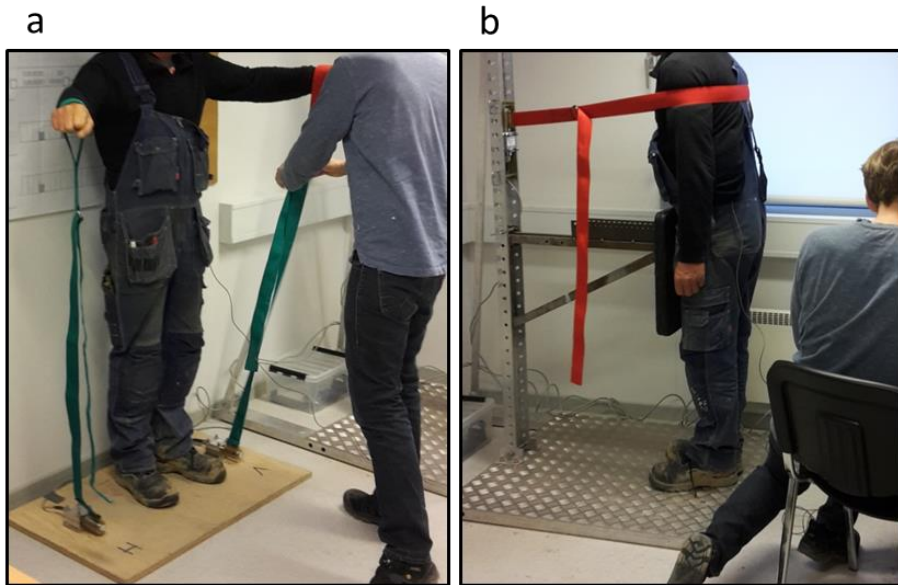

Figure 9: Illustration of MVCs including strength measurements, a: for the shoulders, and b: for the low back.

2.9. QUESTIONNAIRES

Questionnaires were used in the evaluation of the intervention study (Study IV) and were handed out in paper form just before the measurement day, i.e. at baseline, first and second follow-up. The baseline questionnaire included 47 questions while the follow-up questionnaires included 29 questions. The questions covered work ability (105,106), social capital (107), physical workload and fatigue, social relationship and work culture within the construction gangs and at the construction site (108).

2.10. RANDOMIZATION

Study II, III and IV were all randomized. In Study II and III, the order of the lifts performed was randomized in a counter-balanced order. In Study IV, a cluster block randomization was used for the intervention.

In short, in Study II and III concealed opaque unmarked envelopes were prepared before study start. The participants drew an envelope containing their randomized order of the lifts. For the intervention (Study IV), a blinded researcher performed the

cluster randomization with clusters of construction gangs. The organization of construction work – i.e. work in construction gangs – was the reason for choosing a cluster design where the workers already work as a comprehensive unit, where a regular randomized design would increase the risk of contamination between the groups. For further description concerning randomization processes, see Study I, II, III and IV.

2.11. INTERVENTION

2.11.1. INTERVENTION GROUP - WORKSHOPS

The intervention study (Study IV) consisted of three workshops performed over a period of three months (Figure 5). The workshop procedure was carried out with a rolling start for practical reasons and was initiated shortly after completion of the baseline test. See Study I and IV for details regarding the workshop programme.

In brief, 29 construction workers participated in workshop 1 (Figure 10) (see Figure 1 and Table 5 in Study IV for further details) that lasted up to 3.5 hours and consisted of the following, in chronological order:

1. Introduction to the workshop and agenda, i.e. that we expected to have a dialog in a friendly tone and with an open heart.
2. Presentation of ten video recordings with work tasks with excessive physical workload from the specific construction gang. These video recordings were selected from a principle of generalizability, i.e. that the work task appeared several times for the specific gang in question or could be indexed in themes (e.g., heavy lifting).
3. To increase relevance of the selected work tasks, the participants were asked to score each work task with excessive physical workload from 1 to 10, where 1 was extremely easy and 10 was extremely heavy.
4. Each participant now had to select three work tasks that he would prefer to change. The tasks that most participants preferred to change had the highest priority (Figure 10).
5. The construction gang came up with suggestions to decrease the physical workload in the selected work tasks from an ideal world.
6. The construction gang was asked to find realistic solutions to decrease the physical workload within the setting of their workplace.
7. Discussion on ideas and solutions including potential barriers.
8. Preparation of an action plan on how to implement changes at the workplace in relation to the selected work tasks with excessive physical workload.



Figure 10: Pictures from a workshop, a: Participants are introduced to video clips of excessive physical workload, b: Example of work tasks chosen by the participants.

Workshop 2 had 25 participants, lasted up to 3.5 hours and consisted of the following, in chronological order:

1. Presentation of previous research in the construction industry.
2. With the action plan as a point of departure, the participants discussed what had happened since the first workshop.
3. Discussion on new ideas and solutions.
4. Evaluation of the action plan.

Finally 22 participants attended in workshop 3 that lasted up to 3 hours and consisted of:

1. Discussion on the action plan in relation to experiences and new ideas.
2. A long-term action plan was developed with the purpose to secure long-lasting solutions within the construction gang.

2.11.2. CONTROL GROUP

The control group received handouts about WMSD and the negative influence in working life (109), and the Danish Working Environment Authority's lifting guidelines (110). See Study I and IV for more details.

2.12. STATISTICS

The statistics for the present PhD-thesis are made in SAS version 9.4, Microsoft Excel and Matlab (MathWorks, Natick, MA, USA). For a detailed description see Study I, II, III and IV.

In Study II, relative and absolute reliability in terms of $ICC_{3,K}$, SEM and MDC were calculated (80,111,112) using SAS. Further, maximal root mean square values were compared from day 1 and day 2, using a student's t-test and Pearson's correlation coefficient (Microsoft Excel).

In Study III, a custom made Matlab programme was used to categorize lifts into low and high risk and to estimate the accuracy of this classification.

In Study IV, possible differences were calculated using student's t-test (SAS). Linear mixed model (proc mixed, SAS) was used to calculate differences between the intervention and control group from baseline to follow-up (*group-by-time* interaction test). Furthermore, differences from the questionnaires were calculated using Fischers exact test (SAS).

CHAPTER 3. RESULTS

The following chapter gives a short presentation of the results from the two method studies and the intervention study. For further details about tables and figures, please refer to Study II, III and IV. Since Study I is a study protocol, no results are provided from this study.

3.1. RELIABILITY OF SURFACE ELECTROMYOGRAPHY (STUDY II)

The main results of the study are presented in the following; see Study II for further details.

The results of the relative reliability showed no difference between day 1 and day 2 in absRMS or normRMS (table 3 and 4, Study II). In general, the results showed higher ICC for absRMS compared to normRMS and for the right trapezius compared to the left trapezius, respectively.

When taking all lifting situations into account, i.e. lifts from floor to table and lifts from table to table, three lifting situations were considered poor, three were fair, eight were moderate, 12 were substantial, and 30 were almost perfect for the absRMS. And with the same categorization for normRMS, three lifting situations ICCs were considered poor, 12 were fair, 14 were moderate, 17 were substantial, and ten were almost perfect. Altogether, 89 %, and 73 % of the lifting situations were in the range from moderate to almost perfect for absRMS and normRMS, respectively.

The results of the absolute reliability in terms of SEM, SEM%, MDC and MDC%, showed in general lower reliability for lifts from floor to table and similar values for absRMS and normRMS (table 5 and 6, Study II).

3.2. ACCURACY OF IDENTIFICATION OF LOW OR HIGH RISK LIFTING SITUATIONS (STUDY III)

The main results of the study are presented in the following, see Study III for further details.

According to the sensitivity analysis, there was no difference between 90th, 95th and 99th percentile thresholds. From a random resampling procedure across all 100

resampling procedures the confusion matrix of the LDA showed an average accuracy of the classification of 21.2% (SD 2.1), 20.9% (SD 2.1) and 20.3% (SD 1.9) for the 90th, 95th and 99th percentile, respectively (table 2, Study III). The average accuracy of classification increased to 65.1% (SD 1.8), 65.0% (SD 1.9) and 64.5% (SD 1.7) for the 90th, 95th and 99th percentile, respectively, when LDA was applied to discriminate between high and low risk lifts (table 3, Study III).

When identifying high and low risk lifts based on the subject-specific threshold, the accuracy from the confusion matrix was 58.1%, 55.7% and 52.1% and 78.1%, 76.4% and 72.7% from the low (table 4, Study III) and upper back accelerometer (table 6, Study III), respectively.

3.3. EFFECTS OF A PARTICIPATORY ERGONOMICS INTERVENTION WITH TECHNICAL MEASUREMENTS OF PHYSICAL WORKLOAD (STUDY IV)

The main results of the intervention study are presented in short in the following, see Study IV for further details.

The flow and dropout, including technical issues, through the study is outlined in (figure 1, Study IV). The majority of the participants who dropped out of the study were not employed at the construction sites anymore.

The results for the primary outcome did not show a decrease in the number of events with excessive physical workload. Explorative analyses of higher reference cut point confirmed this finding (table 2, Study IV).

The result of the secondary outcome showed a decrease in general fatigue after a typical working day from baseline to second follow-up, in the intervention group (table 3, Study IV). Further, influence of own work increased from baseline to first follow-up in the intervention group (table 3, Study IV).

In the following section, additional results from Study IV are presented. While these results are not included in the submitted manuscript due to limitations in either word count or number of figures, they are included in the thesis for a more complete understanding.

The explorative analyses are presented in Table 3, and include higher reference cut point from the MVCs, and *per protocol* analyses, and analyses including only the erector spinae muscles. The results did not change the conclusion from the analyses

of the primary outcome (table 2, Study IV), i.e. there was no group-by-time effect. However, a within-group difference was observed from baseline to first follow-up. For the control group the within-group difference occurred in the following analysis: 100% sEMG from reference lifts, *Per protocol*, the back of 100% sEMG, *intention to treat*, and the back of 100% reference lifts, *intention to treat*. The intervention group had a within-group difference in the analysis of the back of 100% reference lifts, *intention to treat* (Table 3).

Figure 11 presents the force that the construction workers could perform during the MVCs for the back (Figure 11a) and for the shoulders (Figure 11b). The results showed no significant differences between days or within-group for these measurements.

Intra-day (i.e. from the morning and afternoon sessions) reliability of the sEMG from the erector spinae and trapezius muscles obtained during reference lifts and MVCs is presented in Bland-Altman plots in Figure 12. Furthermore, Figure 13 presents inter-day reliability for sEMG obtained during reference lifts and MVCs from the morning session at the baseline and first follow-up, respectively.

PARTICIPATORY ERGONOMICS INTERVENTION WITH TECHNICAL MEASUREMENTS IN THE CONSTRUCTION INDUSTRY

	Baseline	First follow-up	Second follow-up	Between group difference at follow-up	
				First follow-up	Second follow-up
<i>100% sEMG from reference lifts - Per Protocol</i>					
I	5.6 (95% CI 5.1 - 6.1)	5.8 (95% CI 5.4 - 6.3)	5.7 (95% CI 5.3 - 6.2)	0 (95% CI -0.5 - 0.6)	0.3 (95% CI -0.3 - 0.9)
C	5.1 (95% CI 4.8 - 5.4)	5.8 (95% CI 5.4 - 6.2)*	5.4 (95% CI 5.0 - 5.8)		
<i>150% sEMG from reference lifts - Per Protocol</i>					
I	4.1 (95% CI 3.4 - 4.8)	4.3 (95% CI 3.7 - 4.9)	3.8 (95% CI 3.1 - 4.4)	0.3 (95% CI -0.6 - 1.1)	0.1 (95% CI -0.8 - 1)
C	3.4 (95% CI 2.9 - 4.0)	4.0 (95% CI 3.4 - 4.6)	3.6 (95% CI 3.0 - 4.2)		
<i>150% sEMG from MVCs - Intention to treat</i>					
I	3.4 (95% CI 2.8 - 4.0)	3.1 (95% CI 2.2 - 3.9)	3.2 (95% CI 2.1 - 4.3)	0.7 (95% CI -0.5 - 1.9)	0.3 (95% CI -1.2 - 1.8)
C	2.8 (95% CI 2.3 - 3.4)	2.3 (95% CI 1.6 - 3.1)	2.9 (95% CI 1.9 - 3.8)		
<i>150% sEMG from MVCs - Per Protocol</i>					
I	3.4 (95% CI 2.3 - 4.4)	2.7 (95% CI 1.6 - 3.8)	2.9 (95% CI 1.7 - 4.2)	0.2 (95% CI -1.5 - 1.8)	0.7 (95% CI -0.9 - 2.4)
C	2.9 (95% CI 2.0 - 3.8)	2.5 (95% CI 1.3 - 3.7)	2.2 (95% CI 1.1 - 3.3)		
<i>Back 100% sEMG from reference lifts - Intention to treat</i>					
I	4.4 (95% CI 4.1 - 4.8)	5.1 (95% CI 4.6 - 5.5)**	4.9 (95% CI 4.3 - 5.6)	0.1 (95% CI -0.5 - 0.7)	0.2 (95% CI -0.6 - 0.9)
C	4.3 (95% CI 4.1 - 4.6)	5.0 (95% CI 4.7 - 5.3)***	4.8 (95% CI 4.4 - 5.2)		
<i>Back 100% sEMG from reference lifts - Per Protocol</i>					
I	4.7 (95% CI 4 - 5.3)	5 (95% CI 4.2 - 5.7)	4.9 (95% CI 4.1 - 5.6)	-0.2 (95% CI -1 - 0.7)	0.2 (95% CI -0.7 - 1.1)
C	4.5 (95% CI 4 - 4.9)	5.1 (95% CI 4.6 - 5.6)	4.7 (95% CI 4.2 - 5.2)		
<i>Back 150% sEMG from reference lifts - Intention to treat</i>					
I	2.5 (95% CI 2 - 3)	3.3 (95% CI 2.6 - 4)	2.8 (95% CI 2 - 3.7)	0.5 (95% CI -0.4 - 1.4)	0.2 (95% CI -0.9 - 1.2)
C	2.1 (95% CI 1.6 - 2.5)	2.8 (95% CI 2.3 - 3.3)****	2.7 (95% CI 2 - 3.3)		
<i>Back 150% sEMG from reference lifts - Per Protocol</i>					
I	2.5 (95% CI 1.5 - 3.5)	3.1 (95% CI 2 - 4.3)	2.5 (95% CI 1.4 - 3.6)	0.7 (95% CI -0.7 - 2.1)	0.1 (95% CI -1.2 - 1.4)
C	2 (95% CI 1.3 - 2.8)	2.4 (95% CI 1.6 - 3.2)	2.4 (95% CI 1.6 - 3.2)		
<i>Back 100% sEMG from MVC - Intention to treat</i>					
I	4.3 (95% CI 3.7 - 4.9)	4.3 (95% CI 3.5 - 5.1)	4.4 (95% CI 3.2 - 5.5)	0.3 (95% CI -0.7 - 1.3)	0 (95% CI -1.4 - 1.4)
C	4.6 (95% CI 4 - 5.1)	4 (95% CI 3.4 - 4.6)	4.4 (95% CI 3.6 - 5.2)		
<i>Back 100% sEMG from MVC - Per Protocol</i>					
I	4.7 (95% CI 3.5 - 6)	4.4 (95% CI 3 - 5.8)	4.3 (95% CI 2.7 - 5.8)	0.1 (95% CI -1.6 - 1.9)	0 (95% CI -1.7 - 1.8)
C	4.6 (95% CI 3.6 - 5.5)	4.3 (95% CI 3.2 - 5.3)	4.2 (95% CI 3.3 - 5.2)		
<i>Back 150% sEMG from MVC - Intention to treat</i>					
I	3.3 (95% CI 2.8 - 3.9)	3.1 (95% CI 2.2 - 4)	3.3 (95% CI 2.2 - 4.4)	0.7 (95% CI -0.4 - 1.8)	0.3 (95% CI -1.1 - 1.8)
C	3.2 (95% CI 2.7 - 3.7)	2.4 (95% CI 1.7 - 3.1)	3 (95% CI 2.1 - 3.9)		
<i>Back 150% sEMG from MVC - Per Protocol</i>					
I	3.7 (95% CI 2.6 - 4.8)	2.5 (95% CI 1.2 - 3.9)	3 (95% CI 1.5 - 4.5)	-0.2 (95% CI -2.1 - 1.7)	0.3 (95% CI -1.7 - 2.2)
C	3.2 (95% CI 2.3 - 4.1)	2.7 (95% CI 1.5 - 4)	2.8 (95% CI 1.6 - 3.9)		

Table 3: Explorative analyses of events of excessive physical workload, based on reference values of reference lifts and MVCs. * indicates within-group difference between baseline and first follow-up. *P=0.004, **P=0.022, ***P=0.003 and ****P=0.029.

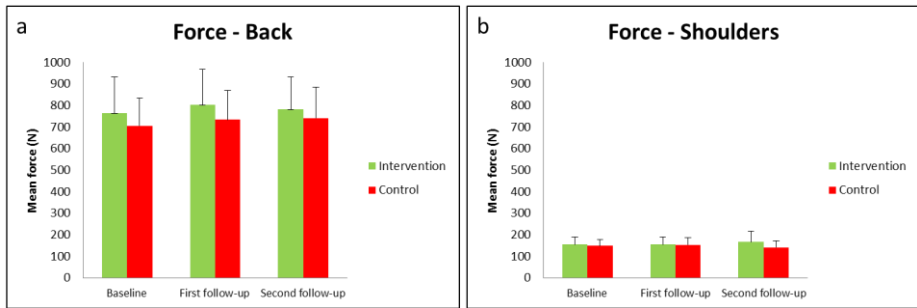

Figure 11: Force measured during the MVC for the back (erector spinae) (a) and for the shoulders (trapezius) (b). Presented as mean \pm SD.

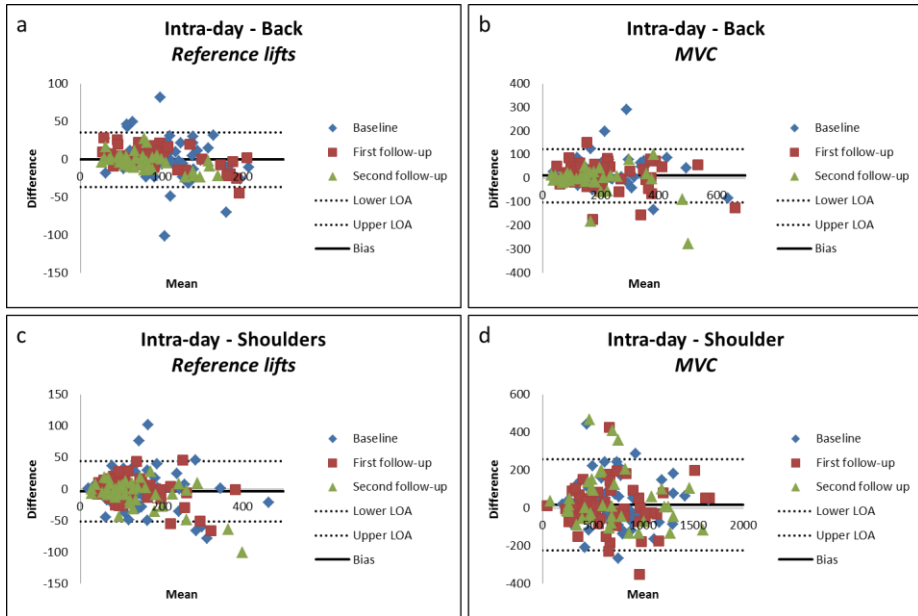

Figure 12: Bland-Altman plots of the intra-day reliability of sEMG obtained from reference lifts and MVCs. Mean=Mean sEMG from morning and afternoon sessions. Difference=Difference in sEMG from morning and afternoon sessions. Bias=Mean difference in sEMG from morning and afternoon sessions.

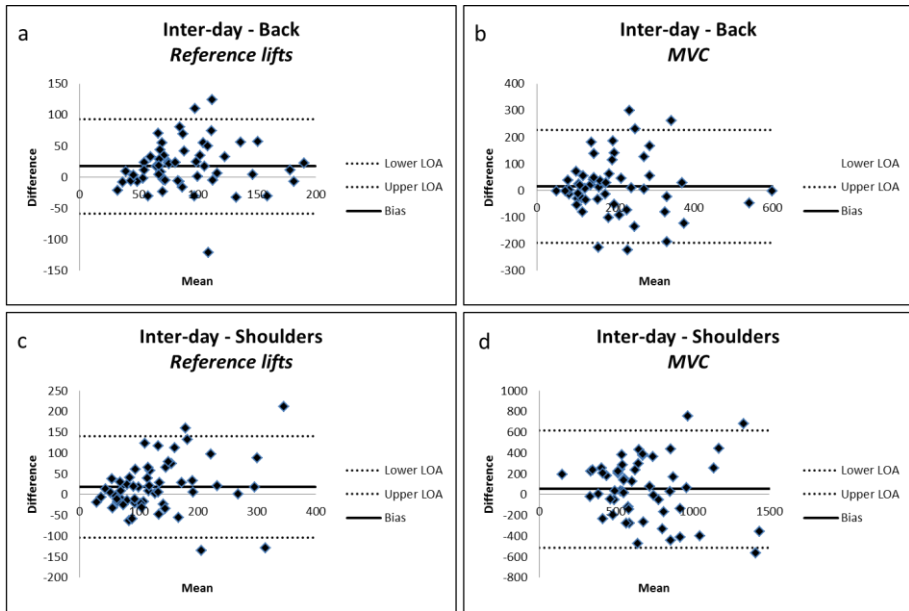

Figure 13: Bland-Altman plots of the inter-day reliability of sEMG obtained from reference lifts and MVCs. Mean=Mean sEMG from morning sessions from baseline and first follow-up, Difference=Difference in sEMG from morning sessions from baseline and first follow-up, Bias=Mean difference in sEMG from morning sessions from baseline and first follow-up.

CHAPTER 4. DISCUSSION

Because the findings of the studies included in this PhD-thesis have been discussed separately in Study I-IV, the following discussion will tie the ends together and focus on how the studies fit together.

The main findings of the present PhD-thesis are that the intervention showed no change in the number of events with excessive physical workload during a working day of construction work. However, a decrease in general fatigue after a typical working day from baseline to second follow-up in the intervention group was observed. Moreover, the influence of own work increased from baseline to first follow-up in the intervention group. The results of the method development studies showed that inter-day reliability of sEMG of the erector spinae and trapezius muscles showed high reliability in most lifting situations during standardized box lifting, according to definitions by Landis & Koch (112). Furthermore, the accuracy of detecting events of excessive physical workload based on technical measurements showed an accuracy of up to 78.1%.

The first part of the discussion will concern development of the method since an essential proportion of this PhD-thesis has been dedicated to this, due to the fact that no previous studies have combined the three methods sEMG, kinematics and video recordings to detect work tasks of excessive physical workload. The remaining part of the discussion will be on the intervention study followed by a section of the challenges of performing research in the construction industry.

4.1. RELIABILITY OF SURFACE ELECTROMYOGRAPHY (STUDY II)

To avoid waste of time and money in research, it is important that the measurement methods used in intervention studies are valid and reliable. In the development of new method for detecting events of excessive physical workload during construction work to be used in Study IV, the first step was to test the inter-day reliability of sEMG signals in Study II. The results of the reliability study showed that maximum absRMS and normRMS had a fair to substantial relative inter-day reliability for the majority of the lifting situations (112). The inter-day reliability was observed to be higher for lifts from table to table than from floor to table for both trapezius and erector spinae muscles. Furthermore, it was found that absolute sEMG had higher reliability than normalized sEMG amplitudes, while absolute reliability (i.e. SEM and MDC) was similar (Study II).

Initially, it was planned to include kinematic measurements from IMU in Study II, but due to technical problems (unreliable sampling frequency), the data had to be

discarded from the analyses. A further description of this issue is provided in Chapter 4.4.1. Because of this, the reliability from the IMU could not be estimated in this study. However, the reliability has been evaluated elsewhere (69,70,99).

The sEMG measurements in the inter-day reliability study show results in line with previous studies (81,82,84,85,113). For further details, see Study II, table 1.

One might argue that the population of the inter-day reliability study was not representative because the participants were from a mix of occupations (e.g. students or office workers) and not construction workers. The selection of this population was made for pragmatic reasons since it was not possible to recruit construction workers to participate in the method development studies. The purpose of Study II was to investigate the inter-day reliability of absolute and normalized amplitude of sEMG measurements obtained during repeated standardized reference lifts. Because the lifting protocol was performed in a standardized manner and in a laboratory environment the population might be of less importance.

As discussed in detail in Study II, sEMG has a number of limitations when used during dynamic muscle work, e.g. the limitation of the volume conductor effect, where the distance to the motor units changes during movements caused by skin movement (114,115). However, this is always a limitation when working with EMG. In relation to translating methods from a laboratory study to the field, there are also some practical issues, e.g. the sEMG electrodes may be more prone to detach from the skin during a full working day where the worker may sweat and move in unpredictable ways compared with controlled laboratory measurements.

Altogether, based on the results from this inter-day reliability study and previous studies in the literature, sEMG seems to be a method with acceptable reliability to be used for the present thesis, keeping the above mentioned limitations in mind.

4.2. ACCURACY OF IDENTIFICATION OF LOW OR HIGH RISK LIFTING SITUATIONS (STUDY III)

The next step in developing a method able to detect events of excessive physical workload was to test the accuracy of detecting situations of known loads from a standardized lifting protocol. Study II showed that sEMG had a fair to substantial relative inter-day reliability for the majority of the lifting situations and based on the literature, it was known that the IMU were reliable as well (69,70,99). However, whether these measurements have the ability to detect low or high risk situations from a standardized lifting protocol was unknown.

The main finding from Study III was that using a subject-specific threshold from sEMG and inclination of the upper back, the LDA provides an accuracy of 78.1%, 76.4% and 72.7% for the 90th, 95th and 99th percentile, respectively, in identifying low or high risk lifts during a standardized protocol. The number of studies in the literature using the LDA to classify lifting is very limited, but one study used the LDA classifier to predict risk for low back pain disorders caused by design of the workplace in industrial job with a 73% accuracy (116). Study III discusses this in further detail.

Another methodological question was the placement of the IMU. The results showed the highest accuracy in identifying lifts as low or high risk based on subject-specific thresholds from the IMU from the upper back compared to an IMU on the low back. This provided valuable information about optimal IMU placement for the intervention study. This finding is in line with a study by Faber et al. (2009) that recommends a sensor placement on the upper back when measuring back inclination (117). Furthermore, the results showed a marked increase in accuracy when individual threshold was applied, which also has been suggested in the literature (118).

As discussed in section 4.1., the generalizability of the results to construction workers could be hampered by the inclusion of healthy males from the general working population.

Due to the accuracy of up to 78.1% in detecting low or high risk lifts from this study, it seems promising for the possibility to detect events of excessive physical workload during construction work based on individual threshold values from sEMG and IMU recordings.

4.3. EFFECTS OF A PARTICIPATORY ERGONOMICS INTERVENTION WITH TECHNICAL MEASUREMENTS OF PHYSICAL WORKLOAD (STUDY I AND IV)

Before initiating the intervention a detailed study protocol was made (Study I), to ensure transparency of the study background, aims, methods, and hypotheses. The main findings of the intervention study, Study IV, were that a participatory ergonomics intervention with three workshops did not change the number of events with excessive physical workload during a working day for construction workers. However, the results based on the questionnaire replies showed positive effects on influence at work and general fatigue after a typical working day, but not on frequency of heavy lifting, pain and perceived workload (secondary outcomes).

The intervention study employed the method developed in Study II and III to detect events of excessive physical workload by using technical measurements during construction work. The approach is novel since previous studies mostly are based on visual observations or self-reported measurements of physical workload. The video recordings obtained from the technical measurements served as a strong visual tool for the participants in the intervention who had the opportunity to see actual work tasks from their own working day, to allow them to find concrete solutions to decrease the physical workload. It should be mentioned that during the workshops, the construction workers could easily recognize most of the identified work tasks as being problematic from a physical workload point of view, and in this way, the video recordings led to several discussions on how to manage the problem. Hence, based on Study II, III and IV, the hypothesis that detection of events of excessive physical workload could be performed based on technical measurements was confirmed. However, the intervention did not reduce the number of events of excessive physical workload during a working day of construction work (Study IV, table 2). Thus, the hypothesis that a participatory ergonomics intervention involving both managers and workers would lead to a reduction in the number of events of excessive physical workload was not confirmed. However, a within-group difference (time difference) was observed from baseline to first follow-up in both the intervention and the control group. Because of this time difference, a number of exploratory analyses were made.

As discussed in Study IV, explorative analyses of higher reference thresholds in terms of 150% sEMG from reference lifts and 100% sEMG from MVCs confirmed the results of the primary outcome. However, these analyses were all performed as *intention-to-treat* analyses and all included both back and shoulder muscles. Hence, analyses of both *intention-to-treat* and *per protocol* are included in the PhD-thesis. Furthermore, an analysis of an even higher threshold of 150% sEMG from MVCs was included (Table 3). The results of these explorative analyses confirmed the results from Study IV. The argument for making analyses including only the back was to study if the events from the shoulders distort the results and thereby to check if the events including only back muscles were affected by the intervention. The reason for including the *per protocol* analyses were to test if the intervention affected the participants who followed the whole intervention period. Furthermore, as discussed in Study IV, a within-group difference was observed in both the intervention and the control group, and the *per protocol* analyses could detect if the participants who dropped out from the study were the participants who could not keep up the work pace. However, the results could not confirm this speculation. To further explore this, within-group difference analysis of 150% MVC was performed, but did not change the result. Overall, this supports the conclusion that the intervention did not lead to a change in the number of events with excessive physical workload.

When writing the study protocol (Study I), it was planned to use 30kg reference lifts. However, according to the Danish Working Environment Authority's lifting guidelines, lifting from the floor is considered an aggravating factor. Thus, although it would not be problematic from an ethical point of view in a research study, the workers would not in a daily work task be allowed to lift 30kg from the floor (110). To maximize the relevance of the research study for subsequent practical use, it was chosen to reduce the load and determine the threshold to 20kg. According to the results, it could be speculated that the cut point for the reference lifts was too low since some of the workers had several hundred events. Furthermore, the results from sEMG normalized to 100% reference lifts showed a within-group difference across different analyses (i.e. adjusted and unadjusted *intention-to-treat* and *per protocol*). These within-group differences were not observed using higher thresholds from reference lifts or MVCs. To explore if the within-group difference was caused by variation in sEMG or muscle strength, additional t-tests were made, and did not show a difference in intra-day sEMG (Figure 11), inter-day sEMG (Figure 12) or muscle strength (Figure 10) from baseline to first follow-up. Thus, the within-group difference does not seem to be explained by a systematic measurement error. Other reasons are discussed in Study IV and could be related to the process of the construction work or habituation effect from wearing the technical equipment. Future studies should consider using a higher threshold for normalization to reference lifts or using MVC, as it seems to eliminate the within-group difference.

The current lifting guidelines like the ones from the Danish Working Environment Authority (110) or The National Institute for Occupational Safety and Health (NIOSH) (119,120) may be complicated for the worker, and may underestimate the workload in awkward positions (121). However, new methods have made it easier to evaluate manual lifting (122). The method proposed in the present PhD-thesis provides the workers with feedback on their work in terms of video recordings of events with excessive physical workload. This new visual feedback might compliment the lifting guidelines and give the possibility to measure the workload in case of doubt.

The number of high-quality intervention studies performed in the construction industry is scarce, mostly based on self-reported measures and most often not conducted in randomized controlled trial designs. A number of non-randomized studies have shown positive effects of participatory ergonomics in the construction industry. Hess et al. (2004) performed a participatory intervention in which they used a lumbar motion monitor to measure the position, velocity and acceleration of the workers' back during work at the construction site. During the intervention the workers modified skid plates for concrete hoses, which reduced low back velocity, acceleration and moments, that may decrease the risk for low back disorders (123). Jong et al. (2003) showed a reduction in self-reported workload in bricklayers using participatory ergonomics (124). The same research group showed a more than 50% adaptation of innovations, measured with questionnaires, through a participatory

approach in the Dutch scaffolding sector; also in a non-randomized study (125). Another study by Jong & Vink (2002) showed a decrease in self-reported physical workload during installation work by implementing participatory ergonomics (126). Dale et al. (2016) showed minimal improvement in short-term and intermediate impacts but no long-term improvements in health outcomes following a participatory ergonomics programme in small commercial construction firms (127). This study concluded that lack of support from contractors was the main reason for not seeing an improvement of the intervention. Furthermore, it was concluded from the process evaluation from the above mentioned study that adoption of complex solutions must involve stakeholders, needs more time and requires a shift in culture or work systems (128). All of these studies are non-randomized and in general based on self-reported measures. However, Van der Molen et al. (2005) studied the effectiveness of a cluster randomized participatory ergonomics intervention in decreasing the physical work demands (129). The results did not show an effect of the intervention and it was recommended that future studies should focus on engaging the stakeholders to make changes. The studies from van der Molen (129) and Dale (127,128) call for more involvement of stakeholders, which is also recommended in a systematic review (86). For this reason the management at the construction sites were involved in the workshops in the present intervention. However, involvement does not necessarily mean support. As discussed in Study IV, the lack of support from the management could be a reason for not seeing a decrease in the number of events of excessive physical workload in the present PhD-thesis. The construction workers came up with several solutions to decrease the workload (Study IV, table 5), but they were often not implemented if they increased the cost for the management. Another reason for not seeing a decrease in the number of events with excessive physical workload could be related to the issue stated in Dale et al. (2017), that implementation of new ergonomic initiatives requires a change in the culture at the construction sites (128). The culture on construction sites is characterized by the belief that the workers have to live with the fact that construction work includes having WMSD (130,131). A third reason for not seeing a decrease could be the relatively short time of the intervention, which might have been too short for implementation of the solution (132,128). The lack of time for implementation could also be seen from the experienced reduced general fatigue and an increased influence on their work following the intervention in the intervention group. This could serve as a predictor for an effect of the intervention and it may have resulted in a decrease in the number of events with excessive physical workload if the intervention period had been longer. However, it may not have been possible in the current design to prolong the intervention, because the dropout caused by end of employment in the present intervention study (Study IV, figure 1) might be increased with a longer intervention period. A fourth reason for not seeing a change in the number of events may be that the intervention targeted only a limited number of work tasks with excessive physical workload. By contrast, some of the participants had several hundred events during the working day, and although some of these probably were repeated work tasks, this also suggests that a long-term

intervention targeting several work tasks may be necessary to measure improvements with the present method.

4.4. CHALLENGES WHEN RESEARCH MEETS PRACTICE

This section will provide a short description of the problems and challenges that occurred during this PhD-thesis. Because they might have relevance to other researchers, practitioners and the perspectives of the thesis, this section is placed before the conclusion of the thesis.

4.4.1. INERTIAL MEASUREMENT UNIT DRIFT

Study II was planned to include IMU synchronized with sEMG signals, but a significant drift in time between the IMU was experienced, even over a short period of time. The drift could be up to 30 seconds during three hours of measurements. It was not possible to ascertain a consistency in this drift in time. This test was performed by using the same equipment used for the synchronization process described in Chapter 2.5.5. The IMU were placed in the device and rotated 95° every 5th minute for ten hours using a rotary solenoid. The manufactures of the IMU (Actigraph) were contacted, and their engineers found out that the problem was related to temperature. If there was a change in the temperature, the sampling frequency simply changed. The manufacturer fixed the problem by a firmware update. After this update, all the IMU were tested in the rotary solenoid for 3*10 hours with a 95° rotation every 5th minute. The results showed that the drift in time had dropped to <1 second during a ten-hour measurement for all IMU, which were considered acceptable. All in all, this issue took several months to solve and caused a postponing of the start of the intervention study, which induced problems with the recruitment of construction sites.

4.4.2. RECRUITMENT

The postponement induced that a major construction site with approximately 40 participants could not participate in the project because their work at this construction site would be finished before the end of the intervention period. The cancellation resulted in several more phone calls and meetings with construction companies and construction gangs than planned in the first place. Furthermore, the intervention ended up being carried out with more (and smaller) construction sites than expected, with a lot more transportation and coordination as a result. However, this could have turned out to be an advantage because more and smaller construction sites reduced the risk for contamination between the construction gangs.

4.4.3. SURFACE ELECTROMYOGRAPHY DRIFT

During Study II a mismatch between the time stamps from the trigger procedure (see Study II) and the noted time from the protocol was experienced. It was tested if the sEMG data-logger drifted in time by using the same method as described in section 4.4.1. A 2 mV signal was sent to the sEMG data-logger every 5th minutes for ten hours and repeated three times for every data-logger. The results showed that the drift was linear, but did not match the expected time between the trigger pulses. Based on the results the calculated actual sampling frequency was estimated to be 1028.54 Hz, instead of the expected 1024 Hz. The sampling frequency at 1028.54 Hz was used in the analysis of the intervention study (Study IV).

4.4.4. CONSTRUCTION WORK IN GENERAL

In research, it is preferable to control everything, or at least as much as possible. To fully control a randomized controlled trial in the construction industry is, however, extremely difficult, e.g. because of the variation in which work tasks the workers are performing during a working day and because of the risk of sudden change in these work tasks because of unpredictable incidents at the construction site.

Another massive challenge by conducting an intervention study with pre and post measurements in the construction industry is that the construction process progresses and thereby the workers are not always performing the same work tasks at the follow-up.

Furthermore, the terms of employment in the construction industry are dominated by short-term contracts, which resulted in a relatively high turnover of workers in the construction gangs which affected the number of participants employed over the entire intervention period.

4.4.5. STRENGTHS AND LIMITATIONS

The refund of lost earnings for the construction workers or construction companies was a definite strength in the recruitment. Without this possibility, the completion of the intervention would have been tough.

A limitation of the present thesis is that we experienced a higher dropout rate during the intervention (Study IV) than expected, which resulted in a small population for the second follow-up. The dropout was primarily caused by changes in the composition of the construction gangs and not because of participants withdrawing from the study.

As mentioned in section 4.4.4. construction work is a challenging type of work to research on, because of various work tasks and sudden changes in work from day to

day or sometimes with even shorter notice, which induces challenges for the researcher who wants standardized measurements. Standardized measurements are probably impossible to obtain in a field study in the construction industry, which is a limitation. On the other hand, a considerable strength of the present study is that the measurements have been conducted during actual construction work.

CHAPTER 5. CONCLUSIONS

The overall aim of this PhD-thesis was to investigate whether a participatory ergonomics intervention with technical measurements consisting of IMU, surface electromyography (sEMG), heart rate and video recordings of physical workload can reduce the number of events with excessive physical workload during a working day in the construction industry (Study protocol, Study I and intervention study, Study IV).

The conclusion of the present PhD-thesis was that a participatory ergonomics intervention did not decrease the number of events with excessive workload during a working day in the construction industry (Study IV). However, the results showed positive effects on the workers' influence at work and general fatigue after a typical working day, but not on frequency of heavy lifting, pain and perceived workload (secondary outcome).

It was hypothesized that a participatory ergonomics intervention involving both managers and workers would lead to a reduction in the events of excessive physical workload. However, this hypothesis could not be confirmed.

To ensure reliable measurement methods for the intervention study (Study IV), the second aim was to develop a reliable and accurate method to detect events of excessive physical workload based on technical measurements during manual lifting (Study II and III).

The results of the method development studies showed fair to substantial relative inter-day reliability for the majority of the lifting situations (Study II) and an accuracy of up to 78.1% in detecting low or high risk lifting situations (Study III). Thus, this confirmed the hypothesis that events of excessive physical workload could be detected based on technical measurements using individual thresholds.

CHAPTER 6. PERSPECTIVES

The results of the present PhD-thesis open several new perspectives.

The considerable amount of data collected was only analyzed to detect events of excessive physical workload. Accordingly, the collected data has the potential to undergo further analyses, e.g. it could be interesting to use a more descriptive approach and investigate how physical demanding the different work tasks are. The data can also be used for a top-down approach of the participatory ergonomics theory, as suggested in Study IV, where the management and occupational professionals find solutions to decrease the physical workload in the construction industry.

The technical measurements used simultaneously and synchronized could be used as a method to evaluate different types of assistive devices and thereby determine which devices apply the lowest physical workload. With the rapid technological development, this is something that could be integrated in portable devices connected to e.g. smartphones and thereby provide the worker with direct feedback to prevent work tasks with excessive physical workload.

The method for detecting events of excessive workload could be applied to other relevant job groups, e.g. manufacturing, and it might serve as a tool for ergonomics improvement.

CHAPTER 7. THESIS AT A GLANCE

Title of study	Aim	Methods	Main findings
Study I			
Participatory intervention with objectively measured physical risk factors for musculoskeletal disorders in the construction industry: Study protocol for a cluster randomized controlled trial.	-	To describe the study design and methods	-
Study II			
Inter-day reliability of surface electromyography recordings of the lumbar part of erector spinae longissimus and trapezius descendens during box lifting.	To investigate the inter-day reliability of the absolute and normalized amplitude of sEMG measurements obtained during repeated standardized reference lifts.	Surface electromyography, Box lifting.	A total of 50 out of 56, i.e., 89%, and 41 out of 56, i.e., 73%, of the lifting situations were in the range from moderate to almost perfect for absRMS and normRMS, respectively.
Study III			
Accuracy of identification of low or high risk lifting during standardized lifting situations.	To assess the accuracy of sEMG and kinematic measurements to detect low or high risk lifts during standardized conditions.	Surface electromyography, Kinematics, Box lifting, Linear Discriminant Analysis.	Identification of lifting situations that pose a low or high risk with an accuracy of 78.1%, 76.4% and 72.7% for the 90th, 95th and 99th percentile, respectively.
Study IV			
Effects of a participatory ergonomics intervention with technical measurements of physical workload in the construction industry: A cluster randomized controlled trial	To investigate whether a participatory ergonomics intervention with technical measurements consisting of IMU sensors, sEMG, heart rate monitoring and video recordings of physical workload would reduce the number of events with excessive physical workload during a working day.	Surface electromyography, Kinematics, Heart rate monitoring, Video recordings, Participatory ergonomics, Detection of physical loading.	The intervention did not reduce the number of situations with excessive physical workload during construction work.

CHAPTER 8. REFERENCES

1. Brandt M, Madeleine P, Ajslev JZN, Jakobsen MD, Samani A, Sundstrup E, et al. Participatory intervention with objectively measured physical risk factors for musculoskeletal disorders in the construction industry: study protocol for a cluster randomized controlled trial. *BMC Musculoskelet Disord.* 2015;16:302.
2. Brandt M, Andersen LL, Samani A, Jakobsen MD, Madeleine P. Inter-day reliability of surface electromyography recordings of the lumbar part of erector spinae longissimus and trapezius descendens during box lifting. *BMC Musculoskelet Disord.* 2017 Dec 11;18(1):519.
3. Brandt M, Madeleine P, Samani A, Jakobsen MD, Skals S, Vinstrup J, et al. Accuracy of identification of low or high risk lifting during standardized lifting situations. *Ergonomics.* 2017 Nov 24;1–24.
4. Brandt M, Madeleine P, Samani A, Ajslev JZ, Jakobsen MD, Sundstrup E, et al. Effects of a participatory ergonomics intervention with technical measurements of physical workload in the construction industry: A cluster randomized controlled trial.
5. Beskæftigelsesministeriet. Folkepension [Internet]. Beskæftigelsesministeriet.dk. 2018 [cited 2018 Jan 6]. Available from: <http://bm.dk/da/Beskaeftigelsesomraadet/Ydelser/Folkepension.aspx>
6. European Commission, Directorate-General for Economic and Financial Affairs. The 2015 Ageing Report - Economic and budgetary projections for the 28 EU Member States (2013-2060) [Internet]. Brussels, Belgium: European Union,; 2015 [cited 2018 Jan 8]. Available from: http://ec.europa.eu/economy_finance/publications/european_economy/2015/pdf/ee3_en.pdf
7. Det Nationale Forskningscenter for Arbejdsmiljø. Arbejdsmiljø i Danmark [Internet]. Arbejdsmiljø i Danmark. 2017 [cited 2017 Dec 27]. Available from: <https://arbejdsmiljoidanmark.nfa.dk/>
8. Burr H, Pohrt A, Rugulies R, Holtermann A, Hasselhorn HM. Does age modify the association between physical work demands and deterioration of self-rated general health? *Scand J Work Environ Health.* 2017 May 1;43(3):241–9.
9. Punnett L, Wegman DH. Work-related musculoskeletal disorders: the epidemiologic evidence and the debate. *J Electromyogr Kinesiol Off J Int Soc Electrophysiol Kinesiol.* 2004 Feb;14(1):13–23.

10. Madeleine P. On functional motor adaptations: from the quantification of motor strategies to the prevention of musculoskeletal disorders in the neck-shoulder region. *Acta Physiol Oxf Engl*. 2010 Jun;199 Suppl 679:1–46.
11. Det Nationale Forskningscenter for Arbejdsmiljø. Fakta om Arbejdsmiljø & Helbred 2016 [Internet]. Copenhagen: Det Nationale Forskningscenter for Arbejdsmiljø; 2017 [cited 2017 Dec 29]. Available from: <http://www.arbejdsmiljoforskning.dk/da/nyheder/arkiv/2017/~~/media/Projekter/AH2016/Fakta-om-Arbejdsmiljoe-og-Helbred-2016.pdf>
12. Morken T, Riise T, Moen B, Hauge SHV, Holien S, Langedrag A, et al. Low back pain and widespread pain predict sickness absence among industrial workers. *BMC Musculoskelet Disord*. 2003 Sep 4;4:21.
13. Sundstrup E, Andersen LL. Hard Physical Work Intensifies the Occupational Consequence of Physician-Diagnosed Back Disorder: Prospective Cohort Study with Register Follow-Up among 10,000 Workers. *Int J Rheumatol*. 2017;2017:1037051.
14. Schneider E, Irastorza X, Copsey S, Verjans M, Eeckelaert L, Broeck V. OSH in figures: Work-related musculoskeletal disorders in the EU - Facts and figures. Luxembourg: European Agency for Safety and Health at Work; 2010.
15. Boschman JS, van der Molen HF, Sluiter JK, Frings-Dresen MH. Musculoskeletal disorders among construction workers: a one-year follow-up study. *BMC Musculoskelet Disord*. 2012;13:196.
16. van den Heuvel SG, Ariëns GAM, Boshuizen HC, Hoogendoorn WE, Bongers PM. Prognostic factors related to recurrent low-back pain and sickness absence. *Scand J Work Environ Health*. 2004 Dec;30(6):459–67.
17. Nyman T, Grooten WJA, Wiktorin C, Liwing J, Norrman L. Sickness absence and concurrent low back and neck-shoulder pain: results from the MUSIC-Norrhälje study. *Eur Spine J Off Publ Eur Spine Soc Eur Spinal Deform Soc Eur Sect Cerv Spine Res Soc*. 2007 May;16(5):631–8.
18. Natvig B, Eriksen W, Bruusgaard D. Low back pain as a predictor of long-term work disability. *Scand J Public Health*. 2002;30(4):288–92.
19. Kamaleri Y, Natvig B, Ihlebaek CM, Bruusgaard D. Does the number of musculoskeletal pain sites predict work disability? A 14-year prospective study. *Eur J Pain Lond Engl*. 2009 Apr;13(4):426–30.

20. Holmberg SAC, Thelin AG. Primary care consultation, hospital admission, sick leave and disability pension owing to neck and low back pain: a 12-year prospective cohort study in a rural population. *BMC Musculoskelet Disord.* 2006;7:66.
21. Bergström G, Bodin L, Bertilsson H, Jensen IB. Risk factors for new episodes of sick leave due to neck or back pain in a working population. A prospective study with an 18-month and a three-year follow-up. *Occup Environ Med.* 2007 Apr;64(4):279–87.
22. Andersen LL, Mortensen OS, Hansen JV, Burr H. A prospective cohort study on severe pain as a risk factor for long-term sickness absence in blue- and white-collar workers. *Occup Environ Med.* 2011 Aug;68(8):590–2.
23. Baldwin ML. Reducing the costs of work-related musculoskeletal disorders: targeting strategies to chronic disability cases. *J Electromyogr Kinesiol Off J Int Soc Electrophysiol Kinesiol.* 2004 Feb;14(1):33–41.
24. Hansson EK, Hansson TH. The costs for persons sick-listed more than one month because of low back or neck problems. A two-year prospective study of Swedish patients. *Eur Spine J Off Publ Eur Spine Soc Eur Spinal Deform Soc Eur Sect Cerv Spine Res Soc.* 2005 May;14(4):337–45.
25. Sundstrup E, Jakobsen MD, Brandt M, Jay K, Ajslev JZN, Andersen LL. Regular use of pain medication due to musculoskeletal disorders in the general working population: Cross-sectional study among 10,000 workers. *Am J Ind Med.* 2016 Nov;59(11):934–41.
26. Dunning KK, Davis KG, Cook C, Kotowski SE, Hamrick C, Jewell G, et al. Costs by industry and diagnosis among musculoskeletal claims in a state workers compensation system: 1999-2004. *Am J Ind Med.* 2010 Mar;53(3):276–84.
27. GBD 2013 DALYs and HALE Collaborators, Murray CJL, Barber RM, Foreman KJ, Abbasoglu Ozgoren A, Abd-Allah F, et al. Global, regional, and national disability-adjusted life years (DALYs) for 306 diseases and injuries and healthy life expectancy (HALE) for 188 countries, 1990-2013: quantifying the epidemiological transition. *Lancet Lond Engl.* 2015 Nov 28;386(10009):2145–91.
28. Hoogendoorn WE, van Poppel MN, Bongers PM, Koes BW, Bouter LM. Physical load during work and leisure time as risk factors for back pain. *Scand J Work Environ Health.* 1999 Oct;25(5):387–403.

29. These MS, Hegmann KT, Wood EM, Garg A, Moore JS, Kapellusch J, et al. Prevalence of low back pain by anatomic location and intensity in an occupational population. *BMC Musculoskelet Disord*. 2014 Aug 21;15:283.
30. Driscoll T, Jacklyn G, Orchard J, Passmore E, Vos T, Freedman G, et al. The global burden of occupationally related low back pain: estimates from the Global Burden of Disease 2010 study. *Ann Rheum Dis*. 2014 Jun;73(6):975–81.
31. GBD 2016 Disease and Injury Incidence and Prevalence Collaborators. Global, regional, and national incidence, prevalence, and years lived with disability for 328 diseases and injuries for 195 countries, 1990–2016: a systematic analysis for the Global Burden of Disease Study 2016. *Lancet Lond Engl*. 2017 Sep 16;390(10100):1211–59.
32. Hoy D, March L, Brooks P, Blyth F, Woolf A, Bain C, et al. The global burden of low back pain: estimates from the Global Burden of Disease 2010 study. *Ann Rheum Dis*. 2014 Jun;73(6):968–74.
33. Ropponen A, Svedberg P, Koskenvuo M, Silventoinen K, Kaprio J. Physical work load and psychological stress of daily activities as predictors of disability pension due to musculoskeletal disorders. *Scand J Public Health*. 2014 Jun;42(4):370–6.
34. Lahelma E, Laaksonen M, Lallukka T, Martikainen P, Pietiläinen O, Saastamoinen P, et al. Working conditions as risk factors for disability retirement: a longitudinal register linkage study. *BMC Public Health*. 2012 Apr 26;12:309.
35. van den Berg TIJ, Elders LAM, Burdorf A. Influence of health and work on early retirement. *J Occup Environ Med*. 2010 Jun;52(6):576–83.
36. Lund T, Iversen L, Poulsen KB. Work environment factors, health, lifestyle and marital status as predictors of job change and early retirement in physically heavy occupations. *Am J Ind Med*. 2001 Aug;40(2):161–9.
37. Ruseckaite R, Collie A. Repeat workers' compensation claims: risk factors, costs and work disability. *BMC Public Health*. 2011;11:492.
38. Lipscomb HJ, Cameron W, Silverstein B. Incident and recurrent back injuries among union carpenters. *Occup Environ Med*. 2008 Dec;65(12):827–34.

39. Wasiak R, Kim J, Pransky G. Work disability and costs caused by recurrence of low back pain: longer and more costly than in first episodes. *Spine*. 2006 Jan 15;31(2):219–25.
40. Coenen P, Gouttebarga V, van der Burght ASAM, van Dieën JH, Frings-Dresen MHW, van der Beek AJ, et al. The effect of lifting during work on low back pain: a health impact assessment based on a meta-analysis. *Occup Environ Med*. 2014 Aug 27;
41. da Costa BR, Vieira ER. Risk factors for work-related musculoskeletal disorders: A systematic review of recent longitudinal studies. *Am J Ind Med*. 2010 Mar;53(3):285–323.
42. Andersen LL, Fallentin N, Ajslev JZN, Jakobsen MD, Sundstrup E. Association between occupational lifting and day-to-day change in low-back pain intensity based on company records and text messages. *Scand J Work Environ Health*. 2017 Jan 1;43(1):68–74.
43. de Cássia Pereira Fernandes R, da Silva Pataro SM, de Carvalho RB, Burdorf A. The concurrence of musculoskeletal pain and associated work-related factors: a cross sectional study. *BMC Public Health*. 2016 Jul 22;16:628.
44. Sterud T, Johannessen HA, Tynes T. Work-related psychosocial and mechanical risk factors for neck/shoulder pain: a 3-year follow-up study of the general working population in Norway. *Int Arch Occup Environ Health*. 2014 Jul;87(5):471–81.
45. Mayer J, Kraus T, Ochsmann E. Longitudinal evidence for the association between work-related physical exposures and neck and/or shoulder complaints: a systematic review. *Int Arch Occup Environ Health*. 2012 Aug;85(6):587–603.
46. Burdorf A, Sorock G. Positive and negative evidence of risk factors for back disorders. *Scand J Work Environ Health*. 1997 Aug;23(4):243–56.
47. Nimbarte AD, Aghazadeh F, Ikuma LH, Harvey CM. Neck disorders among construction workers: understanding the physical loads on the cervical spine during static lifting tasks. *Ind Health*. 2010;48(2):145–53.
48. Lagersted-Olsen J, Bay H, Jørgensen MB, Holtermann A, Sjøgaard K. Low back pain patterns over one year among 842 workers in the DPHacto study and predictors for chronicity based on repetitive measurements. *BMC Musculoskelet Disord*. 2016 Nov 3;17(1):453.

49. Prakash KC, Neupane S, Leino-Arjas P, von Bonsdorff MB, Rantanen T, von Bonsdorff ME, et al. Work-related biomechanical exposure and job strain in midlife separately and jointly predict disability after 28 years: a Finnish longitudinal study. *Scand J Work Environ Health*. 2017 Sep 1;43(5):405–14.
50. Arndt V, Rothenbacher D, Daniel U, Zschenderlein B, Schuberth S, Brenner H. Construction work and risk of occupational disability: a ten year follow up of 14,474 male workers. *Occup Environ Med*. 2005 Aug;62(8):559–66.
51. de Wind A, Geuskens GA, Reeuwijk KG, Westerman MJ, Ybema JF, Burdorf A, et al. Pathways through which health influences early retirement: a qualitative study. *BMC Public Health*. 2013 Apr 3;13:292.
52. Järvholm B, Stattin M, Robroek SJW, Janlert U, Karlsson B, Burdorf A. Heavy work and disability pension - a long term follow-up of Swedish construction workers. *Scand J Work Environ Health*. 2014 Jul;40(4):335–42.
53. Barrero LH, Katz JN, Dennerlein JT. Validity of self-reported mechanical demands for occupational epidemiologic research of musculoskeletal disorders. *Scand J Work Environ Health*. 2009 Jul;35(4):245–60.
54. Takala E-P, Pehkonen I, Forsman M, Hansson G-A, Mathiassen SE, Neumann WP, et al. Systematic evaluation of observational methods assessing biomechanical exposures at work. *Scand J Work Environ Health*. 2010 Jan;36(1):3–24.
55. Eliasson K, Palm P, Nyman T, Forsman M. Inter- and intra- observer reliability of risk assessment of repetitive work without an explicit method. *Appl Ergon*. 2017 Jul;62:1–8.
56. Stock SR, Fernandes R, Delisle A, Vézina N. Reproducibility and validity of workers' self-reports of physical work demands. *Scand J Work Environ Health*. 2005 Dec;31(6):409–37.
57. Kwak L, Proper KI, Hagströmer M, Sjöström M. The repeatability and validity of questionnaires assessing occupational physical activity--a systematic review. *Scand J Work Environ Health*. 2011 Jan;37(1):6–29.
58. Trask C, Mathiassen SE, Wahlström J, Forsman M. Cost-efficient assessment of biomechanical exposure in occupational groups, exemplified by posture observation and inclinometry. *Scand J Work Environ Health*. 2014 May 1;40(3):252–65.

59. Jakobsen MD, Sundstrup E, Persson R, Andersen CH, Andersen LL. Is Borg's perceived exertion scale a useful indicator of muscular and cardiovascular load in blue-collar workers with lifting tasks? A cross-sectional workplace study. *Eur J Appl Physiol.* 2014 Feb;114(2):425–34.
60. Samani A, Holtermann A, Sjøgaard K, Holtermann A, Madeleine P. Following ergonomics guidelines decreases physical and cardiovascular workload during cleaning tasks. *Ergonomics.* 2012;55(3):295–307.
61. Lunde L-K, Koch M, Veiersted KB, Moen G-H, Wærsted M, Knardahl S. Heavy Physical Work: Cardiovascular Load in Male Construction Workers. *Int J Environ Res Public Health.* 2016 Mar 23;13(4):356.
62. Villumsen M, Samani A, Jørgensen MB, Gupta N, Madeleine P, Holtermann A. Are forward bending of the trunk and low back pain associated among Danish blue-collar workers? A cross-sectional field study based on objective measures. *Ergonomics.* 2014 Nov 6;1–13.
63. Arias OE, Caban-Martinez AJ, Umukoro PE, Okechukwu CA, Dennerlein JT. Physical activity levels at work and outside of work among commercial construction workers. *J Occup Environ Med.* 2015 Jan;57(1):73–8.
64. Lagersted-Olsen J, Thomsen BL, Holtermann A, Sjøgaard K, Jørgensen MB. Does objectively measured daily duration of forward bending predict development and aggravation of low-back pain? A prospective study. *Scand J Work Environ Health.* 2016 Jun 1;42(6):528–37.
65. Balaguier R, Madeleine P, Rose-Dulcina K, Vuillerme N. Trunk kinematics and low back pain during pruning among vineyard workers-A field study at the Chateau Larose-Trintaudon. *PLoS One.* 2017;12(4):e0175126.
66. Lunde L-K, Koch M, Knardahl S, Veiersted KB. Associations of objectively measured sitting and standing with low-back pain intensity: a 6-month follow-up of construction and healthcare workers. *Scand J Work Environ Health.* 2017 Mar 8;
67. Wahlström J, Bergsten E, Trask C, Mathiassen SE, Jackson J, Forsman M. Full-Shift Trunk and Upper Arm Postures and Movements Among Aircraft Baggage Handlers. *Ann Occup Hyg.* 2016 Oct;60(8):977–90.
68. Valero E, Sivanathan A, Bosché F, Abdel-Wahab M. Musculoskeletal disorders in construction: A review and a novel system for activity tracking with body area network. *Appl Ergon.* 2016 May;54:120–30.

69. Skotte J, Korshøj M, Kristiansen J, Hanisch C, Holtermann A. Detection of physical activity types using triaxial accelerometers. *J Phys Act Health*. 2014 Jan;11(1):76–84.
70. Korshøj M, Skotte JH, Christiansen CS, Mortensen P, Kristiansen J, Hanisch C, et al. Validity of the Acti4 software using ActiGraph GT3X+accelerometer for recording of arm and upper body inclination in simulated work tasks. *Ergonomics*. 2014;57(2):247–53.
71. Robert-Lachaine X, Mecheri H, Larue C, Plamondon A. Validation of inertial measurement units with an optoelectronic system for whole-body motion analysis. *Med Biol Eng Comput*. 2017 Apr;55(4):609–19.
72. De Luca CJ. Myoelectrical manifestations of localized muscular fatigue in humans. *Crit Rev Biomed Eng*. 1984;11(4):251–79.
73. Konrad P. *The ABC of EMG - A Practical Introduction to Kinesiological Electromyography*. Version 1.0. Vol. 2005. Scottsdale, AZ: Noraxon; 2005.
74. Hanvold TN, Wærsted M, Mengshoel AM, Bjertness E, Stigum H, Twisk J, et al. The effect of work-related sustained trapezius muscle activity on the development of neck and shoulder pain among young adults. *Scand J Work Environ Health*. 2013 Jul;39(4):390–400.
75. Lidegaard M, Jensen RB, Andersen CH, Zebis MK, Colado JC, Wang Y, et al. Effect of brief daily resistance training on occupational neck/shoulder muscle activity in office workers with chronic pain: randomized controlled trial. *BioMed Res Int*. 2013;2013:262386.
76. Mathiassen SE, Liv P, Wahlström J. Cost-efficient measurement strategies for posture observations based on video recordings. *Appl Ergon*. 2013 Jul;44(4):609–17.
77. Reiman A, Pekkala J, Väyrynen S, Putkonen A, Forsman M. Participatory video-assisted evaluation of truck drivers' work outside cab: deliveries in two types of transport. *Int J Occup Saf Ergon JOSE*. 2014;20(3):477–89.
78. Peter P, Elin J, Katarina K, Malin J. Differences in cashiers work technique regarding wrist movements when scanning groceries. *Work Read Mass*. 2012;41 Suppl 1:5436–8.
79. Trask C, Mathiassen SE, Rostami M, Heiden M. Observer variability in posture assessment from video recordings: The effect of partly visible periods. *Appl Ergon*. 2017 Apr;60:275–81.

80. Weir JP. Quantifying test-retest reliability using the intraclass correlation coefficient and the SEM. *J Strength Cond Res Natl Strength Cond Assoc.* 2005 Feb;19(1):231–40.
81. Schinkel-Ivy A, DiMonte S, Drake JDM. Repeatability of kinematic and electromyographical measures during standing and trunk motion: how many trials are sufficient? *J Electromyogr Kinesiol Off J Int Soc Electrophysiol Kinesiol.* 2015 Apr;25(2):232–8.
82. Ghofrani M, Olyaei G, Talebian S, Bagheri H, Kazemi P. Reliability of SEMG measurements for trunk muscles during lifting variable loads in healthy subjects. *J Bodyw Mov Ther.* 2017 Jul;21(3):711–8.
83. Andersen KS, Christensen BH, Samani A, Madeleine P. Between-day reliability of a hand-held dynamometer and surface electromyography recordings during isometric submaximal contractions in different shoulder positions. *J Electromyogr Kinesiol Off J Int Soc Electrophysiol Kinesiol.* 2014 Oct;24(5):579–87.
84. Michener LA, Elmore KA, Darter BJ, Timmons MK. Biomechanical measures in participants with shoulder pain: Intra-rater reliability. *Man Ther.* 2016 Apr;22:86–93.
85. Seitz AL, Uhl TL. Reliability and minimal detectable change in scapulothoracic neuromuscular activity. *J Electromyogr Kinesiol Off J Int Soc Electrophysiol Kinesiol.* 2012 Dec;22(6):968–74.
86. van Eerd D, Cole D, Irvin E, Mahood Q, Keown K, Theberge N, et al. Process and implementation of participatory ergonomic interventions: a systematic review. *Ergonomics.* 2010 Oct;53(10):1153–66.
87. Rivilis I, Van Eerd D, Cullen K, Cole DC, Irvin E, Tyson J, et al. Effectiveness of participatory ergonomic interventions on health outcomes: a systematic review. *Appl Ergon.* 2008 May;39(3):342–58.
88. Nielsen K. Review Article: How can we make organizational interventions work? Employees and line managers as actively crafting interventions. *Hum Rel.* 2013;66(8):1029–50.
89. Craig P, Dieppe P, Macintyre S, Michie S, Nazareth I, Petticrew M. Developing and evaluating complex interventions: the new Medical Research Council guidance. *Int J Nurs Stud.* 2013 May;50(5):587–92.

90. Aust B, Ducki A. Comprehensive health promotion interventions at the workplace: experiences with health circles in Germany. *J Occup Health Psychol.* 2004 Jul;9(3):258–70.
91. Walters D, Wadsworth E, Marsh K. Worker representation and consultation on health and safety. OSHA Europe; 2012.
92. van der Molen HF, Sluiter JK, Hulshof CTJ, Vink P, Frings-Dresen MHW. Effectiveness of measures and implementation strategies in reducing physical work demands due to manual handling at work. *Scand J Work Environ Health.* 2005;31 Suppl 2:75–87.
93. Rinder MM, Genaidy AM, Salem S, Karwowski W. Interventions in the construction industry: A systematic review and critical appraisal. *Hum Factors Ergon Manuf.* 2008 Mar;18(2):212–29.
94. Campbell MK, Piaggio G, Elbourne DR, Altman DG, CONSORT Group. Consort 2010 statement: extension to cluster randomised trials. *BMJ.* 2012 Sep 4;345:e5661.
95. Consort Group. Consolidated standards of reporting trials. Consort Group [Internet]. [cited 2017 Dec 10]; Available from: www.consort-statement.org
96. Chan A-W, Tetzlaff JM, Gøtzsche PC, Altman DG, Mann H, Berlin JA, et al. SPIRIT 2013 explanation and elaboration: guidance for protocols of clinical trials. *BMJ.* 2013;346:e7586.
97. Chan A-W, Tetzlaff JM, Altman DG, Laupacis A, Gøtzsche PC, Krleža-Jerić K, et al. SPIRIT 2013 statement: defining standard protocol items for clinical trials. *Ann Intern Med.* 2013 Feb 5;158(3):200–7.
98. Kottner J, Audigé L, Brorson S, Donner A, Gajewski BJ, Hróbjartsson A, et al. Guidelines for Reporting Reliability and Agreement Studies (GRRAS) were proposed. *J Clin Epidemiol.* 2011 Jan;64(1):96–106.
99. Cleland I, Kikhia B, Nugent C, Boytsov A, Hallberg J, Synnes K, et al. Optimal placement of accelerometers for the detection of everyday activities. *Sensors.* 2013;13(7):9183–200.
100. Feng Y, Wong CK, Janeja V, Kuber R, Mentis HM. Comparison of tri-axial accelerometers step-count accuracy in slow walking conditions. *Gait Posture.* 2017 Mar;53:11–6.

101. Brage S, Brage N, Ekelund U, Luan J, Franks PW, Froberg K, et al. Effect of combined movement and heart rate monitor placement on physical activity estimates during treadmill locomotion and free-living. *Eur J Appl Physiol*. 2006 Mar;96(5):517–24.
102. Kristiansen J, Korshøj M, Skotte JH, Jespersen T, Søgaard K, Mortensen OS, et al. Comparison of two systems for long-term heart rate variability monitoring in free-living conditions--a pilot study. *Biomed Eng Online*. 2011 Apr 12;10:27.
103. Abboud J, Nougrou F, Pagé I, Cantin V, Massicotte D, Descarreaux M. Trunk motor variability in patients with non-specific chronic low back pain. *Eur J Appl Physiol*. 2014 Dec;114(12):2645–54.
104. Jakobsen MD, Sundstrup E, Brandt M, Jay K, Aagaard P, Andersen LL. Effect of workplace- versus home-based physical exercise on musculoskeletal pain among healthcare workers: a cluster randomized controlled trial. *Scand J Work Environ Health*. 2015 Mar;41(2):153–63.
105. Ilmarinen J, Tuomi K. Past, Present and Future of Work Ability. *People Work - Res Rep J Hels Finl Finn Inst Occup Health*. 2004;65: 581-589.
106. Ilmarinen J. Work ability--a comprehensive concept for occupational health research and prevention. *Scand J Work Environ Health*. 2009 Jan;35(1):1–5.
107. Borg V, Mateu N, Clausen T. Udvikling af en ny metode til undersøgelse af social kapital på arbejdspladsen. 2014;
108. Ajslev JZN, Persson R, Andersen LL. Contradictory individualized self-blaming: a cross-sectional study of associations between expectations to managers, coworkers, one-self and risk factors for musculoskeletal disorders among construction workers. *BMC Musculoskelet Disord*. 2017 Jan 10;18(1):13.
109. Arbejdstilsynet. ARBEJDETS UDFØRELSE – D.3.4 (<https://arbejdstilsynet.dk/da/regler/at-vejledninger/a/d-3-4-arbejdsrelateret-muskel-og-skeletbesvaer>) [Internet]. [cited 2017 Dec 12]. Available from: <https://arbejdstilsynet.dk/da/regler/at-vejledninger/a/d-3-4-arbejdsrelateret-muskel-og-skeletbesvaer>
110. Arbejdstilsynet. At-vejledning D.3.1 (<https://arbejdstilsynet.dk/da/regler/at-vejledninger/l/d-3-1-loft-traek-og-skub>) [Internet]. 2005 [cited 2017 Dec 12]. Available from: <https://arbejdstilsynet.dk/da/regler/at-vejledninger/l/d-3-1-loft-traek-og-skub>

111. Shrout PE, Fleiss JL. Intraclass correlations: uses in assessing rater reliability. *Psychol Bull.* 1979 Mar;86(2):420–8.
112. Landis JR, Koch GG. The measurement of observer agreement for categorical data. *Biometrics.* 1977 Mar;33(1):159–74.
113. Andersen CH, Andersen LL, Zebis MK, Sjøgaard G. Effect of scapular function training on chronic pain in the neck/shoulder region: a randomized controlled trial. *J Occup Rehabil.* 2014 Jun;24(2):316–24.
114. Farina D, Merletti R, Enoka RM. The extraction of neural strategies from the surface EMG: an update. *J Appl Physiol Bethesda Md* 1985. 2014 Dec 1;117(11):1215–30.
115. Mesin L. Volume conductor models in surface electromyography: computational techniques. *Comput Biol Med.* 2013 Aug 1;43(7):942–52.
116. Ganga GMD, Esposto KF, Braatz D. Application of discriminant analysis-based model for prediction of risk of low back disorders due to workplace design in industrial jobs. *Work.* 2012;(Supplement 1):2370–2376.
117. Faber GS, Kingma I, Bruijn SM, van Dieën JH. Optimal inertial sensor location for ambulatory measurement of trunk inclination. *J Biomech.* 2009 Oct 16;42(14):2406–9.
118. Balogh I, Hansson GA, Ohlsson K, Strömberg U, Skerfving S. Interindividual variation of physical load in a work task. *Scand J Work Environ Health.* 1999 Feb;25(1):57–66.
119. Waters TR, Putz-Anderson V, Garg A, Fine LJ. Revised NIOSH equation for the design and evaluation of manual lifting tasks. *Ergonomics.* 1993 Jul;36(7):749–76.
120. Waters T, Putz-Anderson V, Garg A. Applications manual for the revised NIOSH lifting equation [Internet] [Internet]. Cincinnati: National Institute for Occupational Safety and Health; 1994 [cited 2017 Jun 6]. Available from: <http://www.cdc.gov/niosh/docs/94-110/>
121. Han B, Stobbe TJ, Hobbs GR. The effect of asymmetry on psychophysical lifting capacity for three lifting types. *Ergonomics.* 2005 Mar 15;48(4):364–79.
122. Waters T, Occhipinti E, Colombini D, Alvarez-Casado E, Fox R. Variable Lifting Index (VLI): A New Method for Evaluating Variable Lifting Tasks. *Hum Factors.* 2016 Aug;58(5):695–711.

123. Hess JA, Hecker S, Weinstein M, Lunger M. A participatory ergonomics intervention to reduce risk factors for low-back disorders in concrete laborers. *Appl Ergon.* 2004 Sep;35(5):427–41.
124. de Jong AM, Vink P, de Kroon JCA. Reasons for adopting technological innovations reducing physical workload in bricklaying. *Ergonomics.* 2003 Sep 15;46(11):1091–108.
125. de Jong AM, van der Molen H, Vink P, Eikhout S, Koningsveld E. Reasons for applying innovations for scaffolding work. *Int J Occup Saf Ergon JOSE.* 2003;9(2):161–75.
126. de Jong AM, Vink P. Participatory ergonomics applied in installation work. *Appl Ergon.* 2002 Sep;33(5):439–48.
127. Dale AM, Jaegers L, Welch L, Gardner BT, Buchholz B, Weaver N, et al. Evaluation of a participatory ergonomics intervention in small commercial construction firms. *Am J Ind Med.* 2016 Jun;59(6):465–75.
128. Dale AM, Jaegers L, Welch L, Barnidge E, Weaver N, Evanoff BA. Facilitators and barriers to the adoption of ergonomic solutions in construction. *Am J Ind Med.* 2017 Mar;60(3):295–305.
129. van der Molen HF, Sluiter JK, Hulshof CTJ, Vink P, van Duivenbooden C, Holman R, et al. Implementation of participatory ergonomics intervention in construction companies. *Scand J Work Environ Health.* 2005 Jun;31(3):191–204.
130. Ajslev J, Lund H, Møller J, Persson R, Andersen L. Habituating pain: Questioning pain and physical strain as inextricable conditions in the construction industry. *Nord J Work Life Stud.* 2013;3(3):195–218.
131. Boatman L, Chaplan D, Teran S, Welch LS. Creating a climate for ergonomic changes in the construction industry. *Am J Ind Med.* 2015 Aug;58(8):858–69.
132. Van Eerd D, King T, Keown K, Slack T, Cole DC, Irvin E, et al. Dissemination and use of a participatory ergonomics guide for workplaces. *Ergonomics.* 2016 Jun;59(6):851–8.

CHAPTER 9. APPENDICES

Appendix I - STUDY I

Brandt, M., Madeleine, P., Ajslev, J.Z.N., Jakobsen, M.D., Samani, A., Sundstrup, E., Kines, P., and Andersen, L.L. (2015). *Participatory intervention with objectively measured physical risk factors for musculoskeletal disorders in the construction industry: study protocol for a cluster randomized controlled trial*. BMC Musculoskelet. Disord.

Appendix II - STUDY II

Brandt M, Andersen LL, Samani A, Jakobsen MD, Madeleine P. (2017). *Inter-day reliability of surface electromyography recordings of the lumbar part of erector spinae longissimus and trapezius descendens during box lifting*. BMC Musculoskelet Disord.

Appendix III - STUDY III

Brandt M, Madeleine P, Samani A, Jakobsen MD, Skals S, Vinstrup J, Andersen LL. (2017). *Accuracy of identification of low or high risk lifting during standardized lifting situations*. Ergonomics.

Appendix IV - STUDY IV

Brandt M, Madeleine P, Samani A, Ajslev JZN, Jakobsen MD, Sundstrup E, Andersen LL. *Effects of a participatory ergonomics intervention with technical measurements of physical workload in the construction industry: A cluster randomized controlled trial*. Submitted, January 2018.

ISSN (online): 2246-1302
ISBN (online): 978-87-7210-158-3

AALBORG UNIVERSITY PRESS