



Aalborg Universitet

AALBORG UNIVERSITY
DENMARK

Reliability-Oriented Design of Power Electronics-Based Power Systems

Sandelic, Monika

DOI (link to publication from Publisher):
[10.54337/aau679677396](https://doi.org/10.54337/aau679677396)

Publication date:
2023

Document Version
Publisher's PDF, also known as Version of record

[Link to publication from Aalborg University](#)

Citation for published version (APA):
Sandelic, M. (2023). *Reliability-Oriented Design of Power Electronics-Based Power Systems*. Aalborg Universitetsforlag. <https://doi.org/10.54337/aau679677396>

General rights

Copyright and moral rights for the publications made accessible in the public portal are retained by the authors and/or other copyright owners and it is a condition of accessing publications that users recognise and abide by the legal requirements associated with these rights.

- Users may download and print one copy of any publication from the public portal for the purpose of private study or research.
- You may not further distribute the material or use it for any profit-making activity or commercial gain
- You may freely distribute the URL identifying the publication in the public portal -

Take down policy

If you believe that this document breaches copyright please contact us at vbn@aub.aau.dk providing details, and we will remove access to the work immediately and investigate your claim.

**RELIABILITY-ORIENTED DESIGN
OF POWER ELECTRONICS-BASED
POWER SYSTEMS**

**BY
MONIKA SANDELIC**

DISSERTATION SUBMITTED 2023



AALBORG UNIVERSITY
DENMARK

Reliability-Oriented Design of Power Electronics-Based Power Systems

Ph.D. Dissertation
Monika Sandelic

Dissertation submitted September, 2023

Dissertation submitted: September, 2023

PhD supervisor:: Prof. Frede Blaabjerg
Aalborg University, Denmark

Assistant PhD supervisors: Asst. Prof. Ariya Sangwongwanich
Aalborg University, Denmark
Asst. Prof. Saeed Peyghami
Aalborg University, Denmark

PhD committee: Associate Professor Yajuan Guan (Chair)
Aalborg University, DK
Professor Brad Lehman
Northeastern University, USA
Reader Alessandra Parisio
University of Manchester, UK

PhD Series: Faculty of Engineering and Science, Aalborg University

Department: AAU Energy

ISSN (online): 2446-1636
ISBN (online): 978-87-7573-618-8

Published by:
Aalborg University Press
Kroghstræde 3
DK – 9220 Aalborg Ø
Phone: +45 99407140
aauf@forlag.aau.dk
forlag.aau.dk

© Copyright: Monika Sandelic

Printed in Denmark by Stibo Complete, 2023

Abstract

Power system modernization, characterized by the extensive integration of renewable energy-based generation, is one of the fundamental actions undertaken by humanity's need for a sustainable future. In such a radical transitioning process, it is essential to ensure that the modern power system is reliable. Power electronics are one of the integral parts of the modern power system, which can also have a severe reliability impact. Current power system planning and operation guidelines need to be re-defined, as they are largely inadequate for assessing the power electronics reliability impacts.

Accordingly, in this Ph.D. project, the long-term and operational impact of power electronics on the power system are investigated. To address the power system challenges introduced by the power electronics, the power electronics reliability is integrated into the long-term modern power system planning. This entails 1) a novel model for long-term generation capacity forecast, and 2) models for power electronics-based power system generation sizing. The former is the highlight of this Ph.D. project, which enables forecasting of generation profiles for power system generation capacity planning with included prediction of power converter lifetime. The model testing demonstrates its accuracy that goes beyond the conventional state-of-the-art methods. The latter comprises an extensive investigation of various external and operational impact on power electronics reliability, generation sizing and overall economic profitability in the case of a single-generator power system. It also defines the optimization procedure for multi-generator power systems that includes the fundamental power electronics reliability impacts into the sizing decisions.

To account for the power electronics benefits in the power system, their grid support functionalities (characteristics of smart inverters) during contingency events in operation are investigated. This includes the development of a novel procedure for a realistic assessment of the power system reliability improvements through smart inverter utilization. Such assessment is, similar to the proposed long-term guidelines, intended to be used to plan and operate a reliable modern power electronics-based power system.

Resumé

Moderniseringen af elsystemet er kendetegnet ved omfattende integration af vedvarende energikilder og er en af de fundamentale handlinger, der er nødvendige for menneskehedens behov for at skabe en bæredygtig fremtid. I en så radikal omstillingsproces er det vigtigt at sikre, at de moderne elsystemer er pålideligt. Effektelektronik er en af de integrerende dele af det moderne elsystem, men som også kan have en alvorlig påvirkning på pålideligheden. De nuværende retningslinjer for elsystemets planlægning skal omdefineres, da de er utilstrækkelige til at vurdere effektelektronikkens indvirkning på pålideligheden.

I dette ph.d.-projekt undersøger vi derfor effektelektronikkens langsigtede og driftsmæssige indvirkninger på elsystemet. For at løse de udfordringer, som effektelektronikken introducerer for elsystemet, integreres effektelektronikkens pålidelighed i den langsigtede planlægning af det moderne elsystem. Dette indebærer 1) en ny model til langsigtet prognose af el-produktionskapacitet og 2) modeller til effektelektronik-baseret dimensionering af elsystemets produktion. Førstnævnte er de primære i dette ph.d.-projekt, som gør det muligt at forudsige produktionsprofiler til planlægning af el-produktionskapacitet i elsystemet med inkluderet forudsigelse af effektkonverternes levetid. Test af modellen viser, at dens nøjagtighed overgår de konventionelle state-of-the-art metoder. Sidstnævnte omfatter en omfattende undersøgelse af forskellige eksterne og driftsmæssige påvirkninger af effektelektronikkens pålidelighed, produktionsdimensionering og overordnede økonomiske rentabilitet i forbindelse med et elsystem med en enkelt generator. Den definerer også en optimeringsprocedure for elsystemer med flere generatorer, som inkluderer de grundlæggende effektelektroniske pålidelighedspåvirkninger i forbindelse med dimensioneringen.

For at kunne tage højde for fordelene ved effektelektronik i elsystemet undersøges også deres net-støttende funktioner (egenskaber ved intelligente invertere) under nød-drift. Dette omfatter udviklingen af en ny procedure til en realistisk vurdering af forbedringerne af elsystemets pålidelighed ved brug af intelligente invertere. Konklusionen er at smarte invertere forbedrer elsystemets pålidelighed. En sådan vurdering er, i lighed med de øvrige

foreslåede langsigtede retningslinjer, beregnet til at kunne blive brugt til at planlægge et mere pålideligt moderne effektelektronik-baseret elsystem.

Contents

Abstract	iii
Resumé	v
Thesis Details	xi
Preface	xiii
I Report	1
1 Introduction	3
1.1 Background	3
1.1.1 Reliability Evaluation of Modern Power Electronics - Based Power Systems	6
1.1.2 Cost Implications for Reliable Design and Operation of Modern Power Systems	8
1.1.3 Power Electronics Reliability Impact on Long-Term Plan- ning of Power Systems	9
1.1.4 Power Electronics Mission Profile Specifications for Long - Term Forecasting in Power Systems	11
1.1.5 Power Electronics Control Impact on Power Systems Reliability	12
1.2 Project Motivation	14
1.3 Project Objectives and Limitations	15
1.3.1 Research Questions and Objectives	15
1.3.2 Project Limitations	16
1.4 Thesis Outline	16
1.5 List of Publications	18

2	Combined Cost/Reliability Modelling of Power Electronics-Based Power System	21
2.1	Background	21
2.2	Proposed Modelling Approach	22
2.2.1	Power System Performance Model	23
2.2.2	Reliability Models	24
2.2.3	Economic Model	25
2.3	Case study: Reliability Impact on Power System Cost	26
2.3.1	Model Application to Power Electronics-Based Power System	26
2.3.2	Power Electronics Reliability Cost	28
2.3.3	Power System Reliability Cost	30
2.4	Summary	32
3	Long-Term Generation Forecasting for Enabling Power Electronics-Based Power System Planning	35
3.1	Background	35
3.2	Proposed Forecasting Methodology	36
3.2.1	Reliability-Driven Clustering	38
3.2.2	Prediction Process	40
3.3	Performance of Reliability-Driven Clustering	41
3.4	Forecast Accuracy	43
3.5	Influence of Data Availability on Forecasting Results	45
3.6	Summary	46
4	Integration of Power Converters Reliability into Long-Term Power System Sizing	49
4.1	Background	49
4.2	Single-Generator Case	50
4.2.1	Impact of Power Electronics Reliability	51
4.2.2	Impact of Mission Profile	53
4.3	Multi-Generator Case	56
4.3.1	Optimization Space	56
4.3.2	Impact of Power Electronics Reliability	59
4.4	Summary	61
5	Investigation of Power Electronics-Aided Generation Impacts on Power System Reliability	63
5.1	Background	63
5.2	Generating Scenarios of Power System Contingencies	64
5.2.1	Mathematical Approach	65
5.2.2	Connection with Scheduling Data	67

Contents

5.2.3	Dynamic Simulations of Power Electronics-Based Power System	68
5.3	Assessment of Power Electronics Grid Support Benefits During Contingencies	69
5.4	Summary	72
6	Conclusion	75
6.1	Summary	75
6.2	Main Contributions	77
6.3	Research Prospects	78
	Bibliography	81
	References	81

Thesis Details

Thesis Title: Reliability-Oriented Design of Power Electronics-Based Power Systems

Ph.D. Student: Monika Sandelic

Supervisors: Prof. Frede Blaabjerg, Aalborg University
Asst. Prof. Ariya Sangwongwanich, Aalborg University
Asst. Prof. Saeed Peyghami, Aalborg University

The main body of this thesis consists of the following papers:

Publications in Refereed Journals

- J1. **M. Sandelic**, S. Peyghami, A. Sangwongwanich, and F. Blaabjerg, "Reliability aspects in microgrid design and planning: Status and power electronics-induced challenges," *Renew. Sust. Energ. Rev.*, vol. 159, pp. 112127-112143, May 2022.
- J2. **M. Sandelic**, Y. Zhang, S. Peyghami, A. Sangwongwanich, and F. Blaabjerg, "Reliability-Driven Clustering Methodology for Probabilistic Forecast of Environmental Conditions in Power Electronics Applications," *Int. J. Electr. Power Energy Syst.*, Status: Under Review.
- J3. **M. Sandelic**, A. Sangwongwanich, and F. Blaabjerg, "Impact of Power Converters and Battery Lifetime on Economic Profitability of Residential Photovoltaic Systems," *IEEE Open J. Ind. Appl.*, vol. 3, pp. 224-236, August 2022.
- J4. **M. Sandelic**, X. Liu, J. Tan, and F. Blaabjerg, "Modern Power System Planning for Enhanced Security: Assessment of Smart Inverters Grid Support Benefits," Status: In Preparation

Publications in Refereed Conference Proceedings

- C1. **M. Sandelic**, A. Davoodi, A. Sangwongwanich, S. Peyghami and F. Blaabjerg, "Multi-Converter System Modelling in Cost for Reliability Studies," in *2021 IEEE 22nd Workshop on Control and Modelling of Power Electronics (COMPEL)*, Cartagena, Colombia, 2021, pp. 1-8.
- C2. **M. Sandelic**, Y. Zhang, S. Peyghami, A. Sangwongwanich and F. Blaabjerg, "Long-Term Forecasting Method for Power Electronics-Based System Design," in *2022 17th International Conference on Probabilistic Methods Applied to Power Systems (PMAPS)*, Manchester, United Kingdom, 2022, pp. 1-6.
- C3. **M. Sandelic**, A. Sangwongwanich, S. Peyghami and F. Blaabjerg, "Reliability Modelling of Power Electronics with Mission Profile Forecasting for Long-Term Planning," in *2022 IEEE 13th International Symposium on Power Electronics for Distributed Generation Systems (PEDG)*, Kiel, Germany, 2022, pp. 1-6.
- C4. **M. Sandelic**, A. Sangwongwanich, S. Peyghami and F. Blaabjerg, "Multi-Year PV Generation Planning Incorporating Power Electronics Impacts in Sizing Decisions," in *2023 IEEE Power and Energy Society General Meeting (PESGM)*, Orlando, FL, USA, 2023, pp. 1-5.

This thesis has been submitted for assessment in partial fulfilment of the Ph.D. degree. Parts of the papers above are used directly or indirectly in the extended summary of the thesis. The co-author statements have been made available to the assessment committee and are also available at the Faculty of Engineering and Science, Aalborg University.

Preface

This Ph.D. thesis summarizes the outcomes of the Ph.D. project "Reliability-Oriented Design of Power Electronics-Based Power Systems", which has been carried out at AAU Energy, Aalborg University, Denmark. This Ph.D. project is supported by the Villum Foundation Denmark through Reliable Power Electronic based Power Systems (REPEPS) project. I would like to extend my gratitude to the aforementioned institutions.

First and foremost, I would like to express my sincere appreciation to my supervisor Professor Frede Blaabjerg. His care, guidance and encouragement to think innovative and explore new research ideas have been of an unprecedented significance for me. I would also like to thank my co-supervisor Assistant Professor Ariya Sangwongwanich, whose share of knowledge and technical discussions, especially at the start of my academic journey, have shaped my fundamental approach to research. I would also like to thank my co-supervisor Assistant Professor Saeed Peyghami for support.

I am deeply grateful to Dr Jin Tan from National Renewable Energy Laboratory (NREL) in Colorado, U.S. I am especially beholden to Dr Jin Tan and Xuebo Liu for the generous amount of time they dedicated to our discussions during my study abroad. I would also like to thank Mrs Robin Lovato, who made my stay at NREL and Colorado that much easier and enjoyable.

During my Ph.D. study, I was lucky to be surrounded by a group of remarkable people. My friends, Andrej, Daniela, Ema, Maday, Mateja, Mateja N., Oksana, Paula, Subham and Yubo, were there for me to make sure that the danish sky was never too dark. I will always be deeply indebted to them.

Last but not least, I would like to express my deepest gratitude to my family, without whom I would have not had as many opportunities in my life. I will be forever humbled for them selflessly choosing to put my dreams ahead of their own. Finally, my heartfelt thank goes to my fiance Christian Vestergaard Jensen, without whom none of this would be possible. Thank you for sharing the sorrows of the challenging days and the celebrations of the remarkable ones with me.

Monika Sandelic
Aalborg University, September 29, 2023

Part I

Report

Chapter 1

Introduction

1.1 Background

To achieve prosperity for mankind and the planet in the future, the United Nations (UN) Member States defined action plans under Sustainable Development Goals (SDG). They entail assuring access to affordable, reliable and sustainable energy. The proposed solutions are also to combat climate change and its impact. For example, UN member states are required to integrate climate change measures into the national policies and strategy planning to combat, among other, rising sea levels, large-scale disasters, and energy-related CO₂ emissions [1]. Led by such goals, the power systems have been undergoing rapid change. The predominately fossil fuel-based generation is being phased out and replaced by a portfolio of renewable energy-based resources, such as wind and solar [2]. This has led to an increase in renewable energy consumption by 25% in 2019 compared to the 2010 level on a global scale [1, 3]. To tackle the negative impact of climate change, it is projected that more than 65% of the total energy consumption needs to come from renewable energy sources by 2030 [4]. Such ambitious targets require a three times faster installation rate of renewable energy-based generation compared to now. In the European Union (EU), the share of final energy consumption is higher than on a global scale. In 2021, it reached 21.8% of the final energy. Some of the EU member states have set more ambitious goals. One example is Denmark, where more than 60% of the electricity consumption was met by renewable energy generation in 2021. This is a result of one of the highest growths in the renewable energy share over a long-term period in the world [5]. Moreover, it is expected that by 2030, 100% of the electricity consumption will be met by renewable energy [6].

The transition in the generation type has been followed by the structural and operational changes of the power system, as well as the introduction of

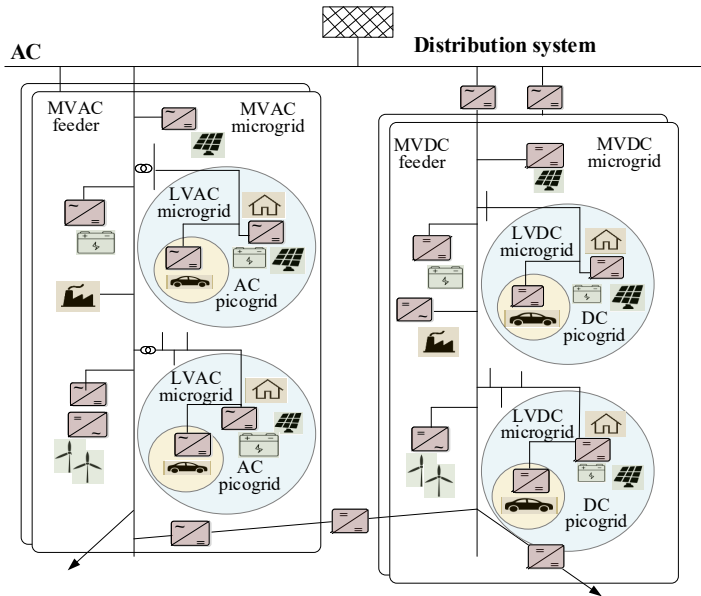

Fig. 1.1: Structure of the modern power electronics-based power system. MVAC & LVAC are medium voltage and low voltage AC grids, and MVDC & LVDC are medium voltage and low voltage DC grids. Source: [7].

new technologies. Power electronics is an example of such technology, which is a vital component of a modern power system. Power electronics is often referred to as the enabling technology for renewable energy-based generators, as it is used as the interface for their connection to the power grid. In a modern power system, it is also utilized for the connection of the storage units and a large number of loads, as illustrated in Fig. 1.1. It is expected that the future power systems will be dominated or fully based on power electronics. Hence, power electronics will have a monumental impact on the power system operation and reliability. Under such resource-based power system structural changes, it is essential to ensure a satisfactory level of reliability. North American Electric Reliability Corporation (NERC) defines reliability as *"the ability of the system to meet the needs of end-use customers even when unexpected equipment failures or other factors reduce the amount of available electricity to meet the electricity needs"* [8]. In a modern power system, it is important to identify how the new technologies impact its reliability. Such investigation should be done over different time scales and it should include both resource adequacy and security of supply. To do so, the main reliability and cost assessment methods need to be revisited and assessed for their suitability to include the impact of new technologies, such as power electronics [8].

Field experience data of the last decade refers that power electronics are a frequent failure cause of the renewable-energy generation systems. Its reli-

1.1. Background

ability was indicated as the key issue as well as the main cause of escalated failure costs [9]. This is supported by more recent reports, where field data from over a thousand wind turbine systems in the United Kingdom during 2016 has shown that power electronics was one of the top five causes of system repair activities [10]. Moreover, the Chinese wind power industry investigation that included 47 wind turbine manufactures, component suppliers, and developers has shown that power converters were a predominant cause of wind turbine system failures [11]. A similar is observed for photovoltaic power plants, where the share of power electronics failures in all system failures was more than 60% [12]. Such observation is aligned with the experience noted in the industrial maintenance reports, where the greatest impact on the system reliability is indicated for the power converter units [13]. These field experiences highlight the need to include power electronics reliability and failure due to ageing in modern power system planning. If such planning guidelines are not revisited for inclusion of power electronics reliability, it can lead to deteriorating power system reliability, which can have substantial societal and economic repercussions.

Power outages are an example of such large-scale events which can lead to severe economic losses as well as long-term costs of a macroeconomic relevance. They are commonly estimated to have economic damage in the scale of millions of euros [14]. Such events have already been seen in practice over the last two decades. One of the most severe global blackouts occurred in the U.S. and Canada in 2003 due to a lack of maintenance and equipment failures. It resulted in no power supply for four consecutive days with more than 50 million people affected. The U.S. Department of Energy (DoE) estimated the economic losses of 6 billion US dollars related to this event [15].

It is, further on, evaluated that several short-term outages can also result in severe socio-economic consequences. For example, up to 160 billion US dollars are lost yearly due to short-term power outages and blackouts in the US [16]. Furthermore, the ageing of the equipment is highlighted as one of the three preconditions for a power outage risk. Given the statistics on power electronics ageing failures and its still unknown effect on power system reliability on a larger scale, it is necessary to include it in future design guidelines. In fact, future guidelines need to be defined in a way, which will enable the investigation of the impact the power converters have on grid reliability. To this end, it is equally significant to exploit newly introduced functionalities that might aid power system reliability. For instance, these include smart control capabilities of the new generation of power converters (i.e., smart inverters). In all, investigating this and other aforementioned aspects is one of the key requirements to expedite the design of a reliable and sustainable modern power system for the future.

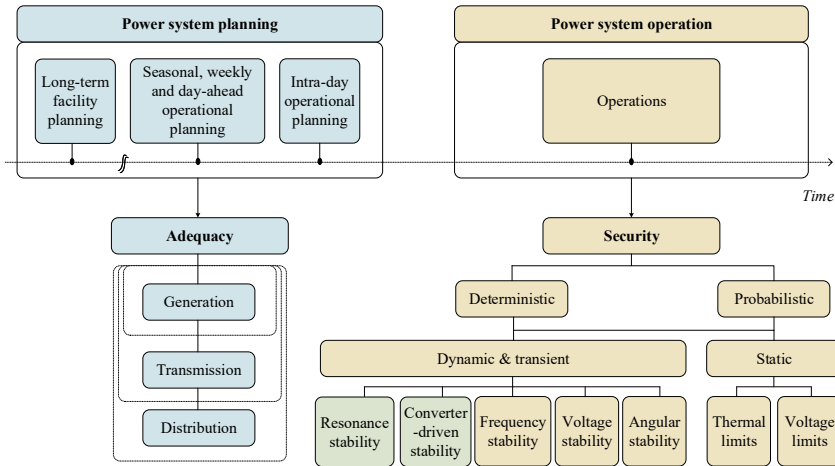

Fig. 1.2: Reliability evaluation framework of a conventional power system with the updated power converter-based security categorization (marked in green) presented in [19] by IEEE Power System Dynamic Performance Committee and the CIGRE Study Committee 38. Source: [20].

1.1.1 Reliability Evaluation of Modern Power Electronics - Based Power Systems

To achieve a high level of power system performance, it is necessary to plan and operate the system economically, with a reasonable level of reliability, while taking into account uncertainties [17,18]. With respect to that, the system reliability assessment and economic evaluation are two main objectives that are taken into account during the planning and operation. In the following, the reliability aspects of a power system are discussed, while the cost implications are considered in the next part.

The reliability evaluation framework in the power system is divided into adequacy and security studies, as shown in Fig. 1.2. The main aim of the adequacy studies is to ensure sufficient generation capacity to cover load demand over the targeted operational span of a system [18]. Such evaluation is done during power system planning, which includes long-term facility planning as well as short-term operational planning (i.e., seasonal, weekly, day-ahead and intra-day planning). Security studies deal with the operation, where the main aim is to ensure that the power system can withstand sudden disturbances and abnormal events [17].

Adequacy evaluation is commonly evaluated with the probabilistic indices. They provide information about the frequency and duration of the interruptions. Moreover, they indicate the service continuity for individual loads (i.e., load point indices) and the groups of loads (i.e., system indices) [21]. To evaluate the load point indices, the failure rates of the load-

1.1. Background

connected components are necessary. Those indices are then used in the evaluation of the system indices. In a conventional power system, the units failure rates are determined from the reliability handbooks [22–24]. There are several different handbooks commonly used, which differ in availability and accuracy [J1]. The majority of the handbooks still exploit constant failure rate data based on historical data, which can often be outdated or only available for obsolete technology. Furthermore, empirical models are often provided without a clear explanation of the failure mechanisms and operating conditions considered. In recent years, a need for a more accurate estimation of failure rates has been pointed out, especially with the introduction of new technologies and the operational changes in the power system. The FIDES model proposed in [25] is an example of a leap forward towards more informative and accurate failure rate estimation. Its working principle is based on the evaluation of different stress phases and physical constraints of the operating conditions. Nonetheless, the FIDES model can only provide the constant failure rates of the units, which only considers random chance failures. Those failures related to the constant failure rate only account for power electronics useful life. Subsequently, the ageing stage starts, where the failure rate is no longer constant. In fact, it increases substantially over time due to wear-out failures, as illustrated in Fig. 1.3.

Thus, in a power electronics-based power system, it is crucial to account for non-constant failure rate as well. This is supported by previous field experience, which has shown that power electronics cause unplanned maintenance activities (where the majority of failures come from ageing), as exemplified in Chapter 1.1. Moreover, global organizations in the power system field, such as CIGRE, have indicated that current reliability procedures,

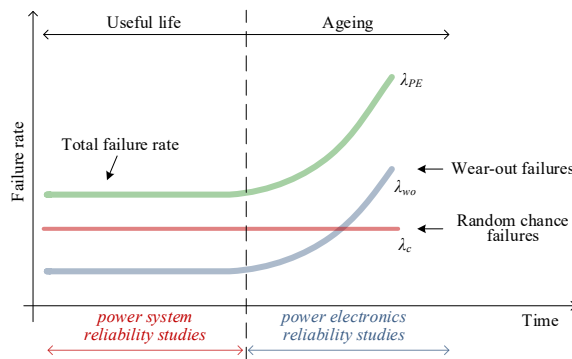

Fig. 1.3: Illustration of the typical failure rate curve of power electronics λ_{PE} . Useful life with constant failure rate λ_c is considered in the power electronics reliability studies, while wear-out phase with non-constant failure rate λ_w is investigated within power electronics reliability. Source: [J1].

which do not include power electronics wear, need to be redesigned to fit modern power system characteristics [26]. Finally, several recent publications have shown an important impact of including the wear-out failure rate of the power converters on system-level reliability indices and adequacy [27,28].

To accurately evaluate the power electronics failure rate due to wear-out, a Physics-of-Failure (PoF) modelling approach is preferred. It includes the failure mechanisms and their root causes. It has already been shown to aid reliability-oriented design and operation of power converters [29–31]. Several efforts have been put forward recently to combine the power electronics and power system reliability approaches. For example, a procedure for a joint assessment of power electronics and power system reliability aspects is proposed in [27]. There, the impact of power converter topology on power system reliability is investigated. The impact of power electronics reliability on maintenance scheduling in the power system is also analysed in [7]. A methodology for a power electronics-based power system is proposed in [32], where the impact of mission profile and repair rate is evaluated on the example of a small power electronics-based power system. The aforementioned research concluded that power electronics reliability has a substantial impact on power system reliability. Nonetheless, to include such a new reliability paradigm requires a change of the design and planning practices, which will be one of the main focus areas of this Ph.D. project.

Research Gap 1 (Planning practices of the modern power system)

It is demonstrated in state-of-the-art research that power electronics affect power system reliability. However, the guidelines on how to systematically assess the power electronics reliability across different power system planning procedures are still missing.

1.1.2 Cost Implications for Reliable Design and Operation of Modern Power Systems

Cost assessment is the second part of the procedure (i.e., reliability being assessed first) that needs to be considered when aiming for a high level of system performance through the design and operation actions. In general, cost assessment includes the estimation of the capital cost and the operation and maintenance cost [33–35]. The capital cost reflects the cost of the investment, which often includes the cost of the system components, the balance of the system, auxiliary hardware and software, and cost of installation. Operation and maintenance cost reflects the cost of system maintenance over the planned operational span. For example, it includes the cost of the system monitoring and the cost of scheduled replacements of the components [36].

1.1. Background

Commonly, the cost assessment is performed together with the revenue evaluation to determine the profitability of the system being planned over the whole operational span [37].

In addition to the aforementioned cost assessment, power system reliability consideration can be added to the analysis. Such practice is especially important when performing the cost-benefit evaluation of the system when reliability improvements are being designed [38]. One way of accounting for this is to translate the reliability indices into the reliability-related cost indices. By doing so, the reliability can be compared with other conditions in a single domain, i.e., through the economic figures of merit. For example, loss of load probability (LOLP) can be translated into the cost of loss of load [35], while expected power not served (EPNS) can be represented with the cost of unserved energy [39]. Power electronics reliability is often included in the cost evaluation of the system without accounting for its actual failure prediction. Commonly, failure rates are taken from the previous field experience and included in the cost analysis of the system [40]. Contrary to this, when the cost is based on the non-constant failure rate prediction based on PoF, an extensive analysis of the power electronics and power system interactions is not performed. Rather, a levelized cost of energy (LCoE), with included power electronics lifetime is determined for the system under study [41].

Research Gap 2 (Cost and reliability assessment of modern power system)

It still remains unclear how the connection of the two reliability costs can be made to fully assess both power electronics and power system reliability in the cost analysis. Furthermore, it is unclear which models need to be employed and how to develop the models and their mutual connection as well as the connection with the standard cost assessment procedure discussed above. In addition, it is unclear in which manner the power electronics reliability and power system reliability-related costs impact the optimum design solutions.

1.1.3 Power Electronics Reliability Impact on Long-Term Planning of Power Systems

Long-term power system planning has typically been conducted for 10-35 years ahead [42], while recently even longer planning horizons are being considered for specific applications [43]. In this process, the main goal is to optimally and economically develop the system over the planning horizon. This entails several different investigations, covered within long-term forecasting and sizing. The latter is identified as the most relevant investigation,

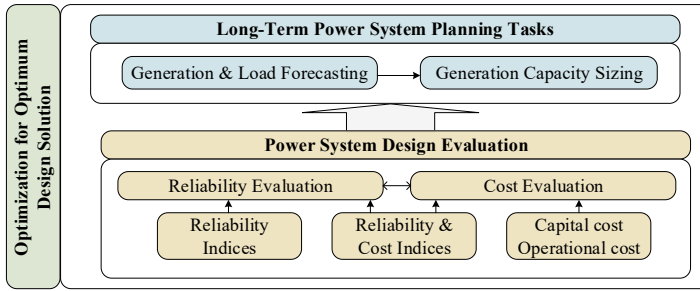

Fig. 1.4: Connection between planning procedures and reliability/cost evaluation of power systems. Source: [J1].

where sizing of generation and storage units to cover the growing load demand is performed [42]. The former is a prerequisite for the sizing procedure, where the forecasting of the input profiles (renewable energy sources, load demand) is conducted. These tasks are connected to the reliability and cost considerations, as shown in Fig. 1.4. Often, different optimization algorithms are employed to find the optimum long-term planning solution [44–47].

A detailed analysis in [J1] reveals that significant efforts are put into long-term power system sizing. In this field, the effects of different modern power system characteristics during the sizing procedure are investigated. Contrary to this, less attention is given to long-term forecasting, where certain challenges have been pointed out. Thus, in the remaining part of this sub-chapter, the review of state-of-the-art long-term power system sizing is presented, while a more detailed analysis of long-term forecasting methods is performed in the following sub-chapter.

As a part of the long-term sizing research, the procedures for sizing and siting of small-scale distributed energy resources have been extensively investigated [42, 48–53]. This approach is especially appealing for the power systems with a large installation rate of the renewable energy-based generation units. In such cases, the flexibility of small distributed units can help in strengthening power system reliability [50]. Several procedures have been proposed, where the impact of different technology types and their characteristic is included in the decision-making process. It is pointed out that different technologies can complement each other, where the limitations of one technology can be covered by another [54]. During the long-term sizing of the system, the influence of different objectives and parameters on the optimum solution is investigated. For example, in [51, 52], the impact of economic figures of merit such as payback time on optimum planning solution is analysed. Moreover, the influence of the variation in generation and load profile characteristics (planning horizon and time resolution) has been investigated in [42]. Another study included the effect of performance degradation

of units on the long-term sizing results [53].

All of the aforementioned research provides valuable information about the impact of different modern power system aspects on long-term planning. The results of such studies can further reduce uncertainty in the power system planning. However, the reliability-related influence of the power electronics (being an integral part of the system) has not been extensively investigated before. In fact, the research on the impact of power electronics on the optimum sizing is very limited and currently focused on the specific application scenarios [55,56]. With respect to that, there are no guidelines on how to include power electronics reliability in the long-term sizing of the power system.

Research Gap 3 (Modern power system sizing)

An extensive impact of power electronics reliability on different aspects of long-term power system sizing as well as the guidelines on future design are still missing. It remains unclear how to include power electronics in the sizing decisions over the long-term horizon.

1.1.4 Power Electronics Mission Profile Specifications for Long - Term Forecasting in Power Systems

The main goal of the forecasting procedure is to predict with sufficient accuracy the renewable generation sources (e.g., solar irradiance, ambient temperature, wind speed) and load demand over a long-term horizon (e.g., several years). A large integration of renewable energy-based generators into the power system in recent years has led to increased research on renewable energy sources forecasting. For example, several models are developed to account for spatial and temporal characteristics [57,58]. Furthermore, the influence of multi-source data on the renewable energy sources dynamics for different time scales was investigated in [58,59]. Significant contributions have also been seen from models developed based on the probabilistic forecasting principles. There, the impact of uncertainties for long-term forecasting horizons was included to further improve the accuracy of the long-term forecasting for renewable energy-based systems [60–63]. Moreover, several studies deal with the impact of forecast uncertainty on the optimum power system sizing results [50,64].

As mentioned earlier, it is necessary to include the power electronics non-constant failure rate in the reliability evaluation. However, to be able to evaluate the power electronics reliability, it is necessary to know the environmental and operation conditions the power converters will be subjected to [65]. This includes the forecasting of power electronics mission profiles which have

specific requirements. To accurately account for the power electronics stress accumulation during the operation, the profiles with high temporal granularity are necessary. They can account for all the changes in the power converter loading during operation. This is especially important in the power system with a large installation rate of renewable energy sources. There, the power electronics loading can change substantially within a couple of minutes [66]. Such abrupt changes can lead to additional stress on the power converter, which has a direct impact on lifetime and reliability. However, current long-term forecasting methods are not suitable for forecasting of profiles with such characteristics. The majority of the methods show deteriorating accuracy with the extension of the prediction horizon. Furthermore, standard long-term forecasting methods are not developed to account for such high temporal granularity. Their working principles are defined based on the requirements of long-term sizing, which require only monthly or yearly updates.

Research Gap 4 (Long-term forecasting with power electronics reliability)

Power electronics have specific requirements for their mission profile that relate to the temporal granularity and prediction horizon. None of the common state-of-the-art methods are suitable in their current form for this task. Hence, it is necessary to develop new forecast methodologies, which will simultaneously provide forecast information that can be used for generation and storage sizing (as in the traditional power system forecasting) and which can be used for the reliability prediction of power electronics converters.

1.1.5 Power Electronics Control Impact on Power Systems Reliability

From the reliability point of view, the main goal of the power system operation is to assure power system security. This means that the system can respond to the disturbances that might occur during the operation [67]. In case of contingencies, the system needs to be able to maintain its stability. The stability investigations in the traditional power systems are usually divided into frequency, voltage and angular stability issues [18], as also shown in Fig. 1.2. Following the contingency scenario, certain preventive and corrective actions are done to ensure that the system security is maintained. Some of the common actions include load curtailment and the rescheduling of the units [17]. In a power system with a large installation rate of renewable energy sources, assuring system security becomes challenging. Renewable energy-based generators are characterized by the intermittent nature of their source. They do

1.1. Background

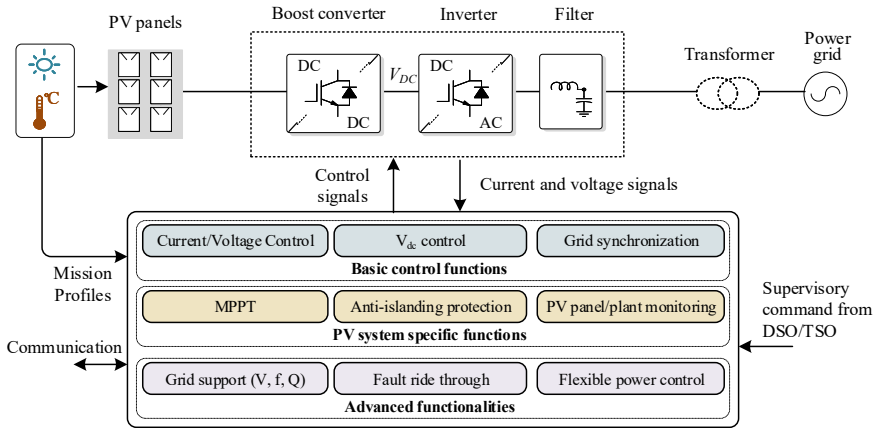

Fig. 1.5: Smart inverter control functionalities illustrated in the example of photovoltaic application. Source: [75].

not follow the load demand in the same way the conventional generators do. This can lead to larger frequency variations and voltage instabilities [68, 69]. Moreover, the power electronics-based power system cannot react to such changes in the same manner as the traditional power system. This is mainly due to the lack of inertia, which is characteristic of a traditional power system due to the rotational energy of conventional generators [70]. In the future, more frequent as well as more severe contingency situations can be expected. With respect to that, a special emphasis needs to be put on dealing with these challenges.

One way of assuring better security is to employ power electronics with grid support capabilities, such as smart inverters [71] illustrated in Fig. 1.5. This relates to power converters active role in supporting power system reliability (i.e., security). The inverters installed a decade ago (i.e., legacy inverters) are actively being replaced by smart inverters [72]. At the same time, new power electronics units are being added to the system. In such a scenario, it becomes important to assess the impact of smart inverters on the power system reliability. From a control point of view, there are several ways the power converters can provide grid support services [73]. They are categorized into active power control, reactive power control and grid fault response [74].

The majority of the research on power converter grid support capabilities is focused on power converter control investigations. There, extensive effort is put into investigating the solutions for cost-effective and optimal realization of different control functionalities of smart inverters [65, 75–77]. Recently, more emphasis has been put on the investigation of smart inverter benefits from the power system perspective. For example, a detailed analysis of the

smart inverter influence on voltage and frequency control of a power system is conducted in [78–81]. Those studies showcase the improvements in power system operation for different penetration levels of smart inverters, as well as indicate cost-saving opportunities for the utilities. Nonetheless, certain aspects of the power system reliability have not been covered in the existing literature, such as grid contingencies during load-shedding events.

Research Gap 5 (Security assessment with smart inverters)

A procedure for investigation of power system reliability under smart inverter control implications for load-shedding events is necessary. With respect to that, it remains unclear how to fully assess the benefits and include such studies in the planning of the system to aid increased rate of power system security.

1.2 Project Motivation

To aid the successful transition towards sustainable power systems, it is of pivotal importance to evaluate new functionalities, as well as address the challenges introduced by renewable energy integration. As discussed in the state-of-the-art review, failure-prone power electronics are indicated as a critical component, which poses a threat to the power system reliability and, consequently, cost. To avoid any deteriorating scenarios which could lead to interruptions in energy supply and blackouts with severe socio-economic consequences, it is necessary to revisit the current power system design guidelines. To that extent, two different power electronics characteristics are identified, i.e., reliability and control-based grid support functionalities. The former is indicated to impact power system adequacy. In such cases, the models which enable power electronics lifetime and reliability investigation during long-term planning need to be developed. This entails forecasting methods which need to enable the prediction of power electronics lifetime. Furthermore, the sizing methods are supposed to include the prediction information into the decision-making process. The latter is indicated as an important solution for aiding power system security. The power system stability needs to be assessed for a range of contingency events in the power system with a high installation rate of smart inverters. Thus, it is necessary to develop guidelines which can systematically account for such benefits. By investigating both aspects and finding adequate solutions, the planning of a reliable power electronics-based system can be performed.

1.3 Project Objectives and Limitations

1.3.1 Research Questions and Objectives

Given the aforementioned motivation, the main research question of this Ph.D. project can be defined:

"How to design a reliable and cost-effective modern power system based on power electronics?"

Given the indicated research gaps and the main research question, several sub-questions are defined as follows:

- How to model a power system with multiple power converters to enable power electronics and power system reliability investigations as well as their interaction with the cost evaluation?
- How to integrate power electronics lifetime and reliability into long-term power system planning procedures?
- How to evaluate the power converter control capabilities to support the power system during contingencies?

Accordingly, the main objectives of the Ph.D. project are summarized as follows:

Modelling of power electronics-based power system under cost and reliability considerations

To evaluate the mutual impact of power electronics and power system reliability as well as their influence on the system cost, a model accounting for those aspects needs to be defined. It should translate environmental and operating conditions over a long-term horizon into reliability and cost indices.

Defining new power system design guidelines which incorporate the lifetime and reliability of power electronics

As discussed previously, the current long-term planning processes are not suitable for the integration of power electronics reliability. In this Ph.D. project, new guidelines for long-term forecasting and sizing need to be provided. They should include the characterization of models, multiple time-scales and data requirements suitable for assessing long-term power electronics impact on power system operation.

Assessment methods for power converters grid support functionalities on power system operation during contingencies

The operational impact of power electronics must be investigated during

power system contingencies. A procedure for assessing the benefits of smart inverter control functionalities for power system reliability is needed.

1.3.2 Project Limitations

Several limitations, assumptions and simplifications have been considered in this Ph.D. project, listed as follows.

Power electronics reliability-related:

- Power converter reliability analysis considers only wear-out failures, where only dominant thermal-related failure mechanisms are taken into account.
- Only the reliability of the power devices is investigated. Other power converter components (such as capacitors) are not considered in the lifetime and reliability assessment.
- A limited number of topologies and power converter design solutions are used as an example during the various analyses that include power electronics reliability.

Power system modelling-related:

- When performing dynamic simulations of the power system, no transient behaviours are investigated, nor the dynamics of the controllers are included.
- Equal resource availability conditions are assumed over the whole power system. Thus, the output power of the resource-dependent renewable energy-based generators is considered proportional across the power system.
- The electrical models of the power lines and other system equipment are not modelled.
- Only under-frequency load shedding is considered for the power system contingency studies.

1.4 Thesis Outline

The main outcomes and the results of the Ph.D. project are summarized in this Ph.D. thesis, which is based on a collection of papers. The Ph.D. thesis is structured into two main parts, i.e., *Report* and *Selected Publications*. The report presents the summary of the main research outcomes during the

1.4. Thesis Outline

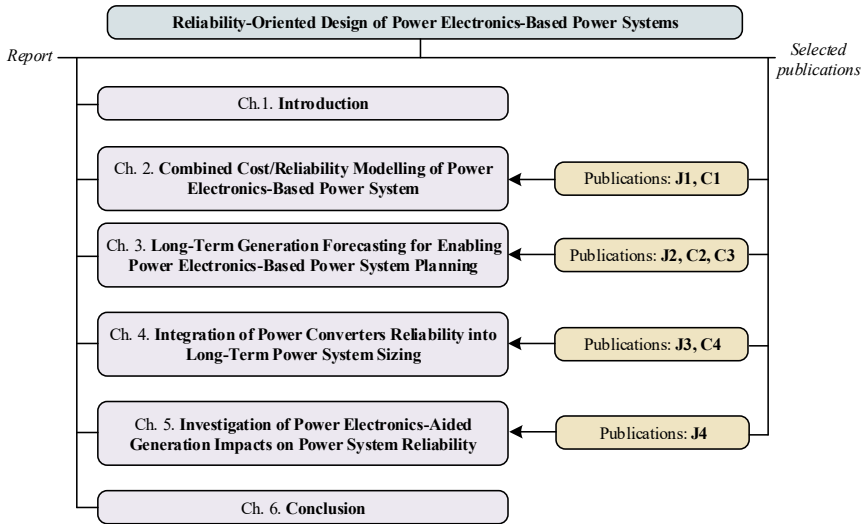

Fig. 1.6: Structure of the Ph.D. thesis report with indicated connection between report parts and the selected publications.

Ph.D. project. Its structure is illustrated in Fig. 1.6, where the connection to the selected publications is also indicated. As shown, the report consists of six main chapters, where in *Chapter 1* the introduction to the Ph.D. project is given. In *Chapter 2*, the main modelling aspects of the power electronics-based power system are proposed. The models necessary for the evaluation of the power electronics reliability and power system reliability are developed. The analysis of two reliability aspects that influence the cost of the system is conducted. This chapter provides the necessary foundation for further investigation of power electronics and power system reliability aspects in the remaining chapters. In *Chapter 3*, a forecast methodology which enables both, power electronics reliability and long-term renewable energy-based generation prediction is presented. The developed method is intended to be used during long-term system planning, where power electronics reliability prediction can be included in the system sizing. With respect to that, in *Chapter 4*, a methodology for power electronics-based power system sizing is presented. Firstly, different environmental and operational impacts on the optimum sizing of a single-generator power electronics-based power system are investigated. Afterwards, an optimization method, which includes power electronics reliability in the long-term sizing of a multi-generator power system, is presented. In *Chapter 5*, a systematic approach to the investigation of the smart inverter benefits during load-shedding conditions is presented. This entails the assessment of the power converter grid support-related control benefits during grid contingencies. Finally, the main findings of the Ph.D.

project are summarized in *Chapter 6*, as well as the prospective research.

1.5 List of Publications

The main research outcomes of the Ph.D. project have been disseminated in journal and conference publications, as listed below.

Publications in Refereed Journals

- J1. **M. Sandelic**, S. Peyghami, A. Sangwongwanich, and F. Blaabjerg, "Reliability Aspects in Microgrid Design and Planning: Status and Power Electronics-Induced Challenges," *Renew. Sust. Energ. Rev.*, vol. 159, pp. 112127-112143, May 2022.
- J2. **M. Sandelic**, Y. Zhang, S. Peyghami, A. Sangwongwanich, and F. Blaabjerg, "Reliability-Driven Clustering Methodology for Probabilistic Forecast of Environmental Conditions in Power Electronics Applications," *Int. J. Electr. Power Energy Syst.*, Status: Under Review.
- J3. **M. Sandelic**, A. Sangwongwanich, and F. Blaabjerg, "Impact of Power Converters and Battery Lifetime on Economic Profitability of Residential Photovoltaic Systems," *IEEE Open J. Ind. Appl.*, vol. 3, pp. 224-236, August 2022.
- J4. **M. Sandelic**, X. Liu, J. Tan, and F. Blaabjerg, "Modern Power System Planning for Enhanced Security: Assessment of Smart Inverters Grid Support Benefits," Status: In Preparation

Publications in Refereed Conference Proceedings

- C1. **M. Sandelic**, A. Davoodi, A. Sangwongwanich, S. Peyghami and F. Blaabjerg, "Multi-Converter System Modelling in Cost for Reliability Studies," in *2021 IEEE 22nd Workshop on Control and Modelling of Power Electronics (COMPEL)*, Cartagena, Colombia, 2021, pp. 1-8.
- C2. **M. Sandelic**, Y. Zhang, S. Peyghami, A. Sangwongwanich and F. Blaabjerg, "Long-Term Forecasting Method for Power Electronics-Based System Design," in *2022 17th International Conference on Probabilistic Methods Applied to Power Systems (PMAPS)*, Manchester, United Kingdom, 2022, pp. 1-6.
- C3. **M. Sandelic**, A. Sangwongwanich, S. Peyghami and F. Blaabjerg, "Reliability Modelling of Power Electronics with Mission Profile Forecasting for Long-Term Planning," in *2022 IEEE 13th International Symposium on Power Electronics for Distributed Generation Systems (PEDG)*, Kiel, Germany, 2022, pp. 1-6.

1.5. List of Publications

- C4. **M. Sandelic**, A. Sangwongwanich, S. Peyghami and F. Blaabjerg, "Multi-Year PV Generation Planning Incorporating Power Electronics Impacts in Sizing Decisions," in *2023 IEEE Power and Energy Society General Meeting (PESGM)*, Orlando, FL, USA, 2023, pp. 1-5.

Chapter 2

Combined Cost/Reliability Modelling of Power Electronics-Based Power System

2.1 Background

To plan for the power system with a high installation rate of the power electronics, it is pivotal to understand its reliability and cost implications. Such practice is widely adopted in traditional power system planning, where the main aim is to develop the system with a required level of reliability under minimum cost [35,39]. For example, different results of the long-term power system sizing can be evaluated for reliability improvements and cost requirements [54]. However, the investigation of power electronics reliability impact is often not included in such analysis, especially when a high installation rate of power electronics is present in the power system. From the power electronics perspective, the reliability evaluation usually covers the design of a single power converter unit. In such cases, corrective design measures are employed to ensure a desired level of converter reliability [29]. This analysis can, similarly to a power system perspective, be conducted together with the cost assessment [82].

Even though that two aspects (i.e., power system reliability and power electronics reliability) seem conceptually similar, the models and requirements differ significantly [J1]. For example, in the power system reliability analysis, it is pivotal to estimate the severity of the events that lead to the

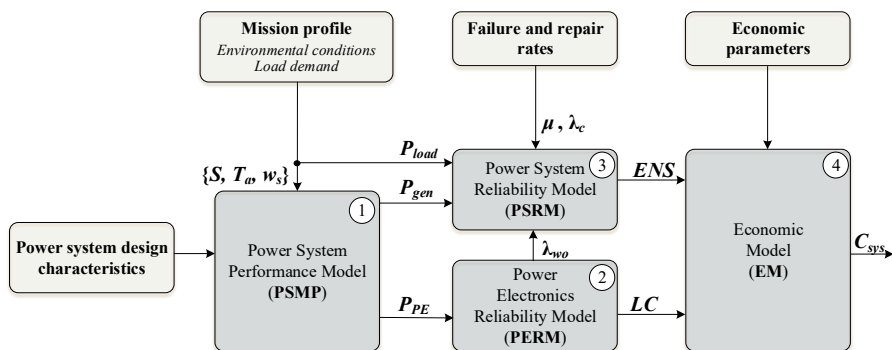

Fig. 2.1: Overview of the proposed model for the reliability and cost evaluation of the modern power electronics-based power system. Source: [C1].

interruptions in the system [83]. This often entails the evaluation of the reliability of the system based on failure and repair rates of the units, where analytical and simulation models are employed [49, 84–86]. Contrary to this, power electronics reliability applies PoF approach to evaluate when the dominant failure mechanisms will be triggered for the reliability-critical components in the power converter [30]. Such analysis includes semi-empirical models which describe the lifetime of the component for the relevant stress variable [87–89].

With respect to that, this chapter is devoted to developing a model suitable for investigation of both power electronics and power system reliability impact on the overall cost of the power electronics-based power system. Moreover, a connection among different aspects (power system performance, lifetime and reliability, and cost) will be defined. The developed model will be employed to evaluate the relative impact of each cost component on the overall cost of the modern power electronics-based power system.

2.2 Proposed Modelling Approach

The developed comprehensive model for cost and reliability studies of the power electronics-based power system is discussed in detail in [C1]. A diagram of the model is illustrated in Fig. 2.1, where a connection between different parts of the model is also indicated. The comprehensive model consists of four main parts, namely 1) Power System Performance Model (PSPM), 2) Power System Reliability Model (PSRM), 3) Power Electronics Reliability Model (PERM), and 4) Economic Model (EM). The developed model provides information about the cost under the influence of different perspectives, including power electronics reliability and power system reliability. A brief description is provided in the following for model 1), model 2) and 3), and

2.2. Proposed Modelling Approach

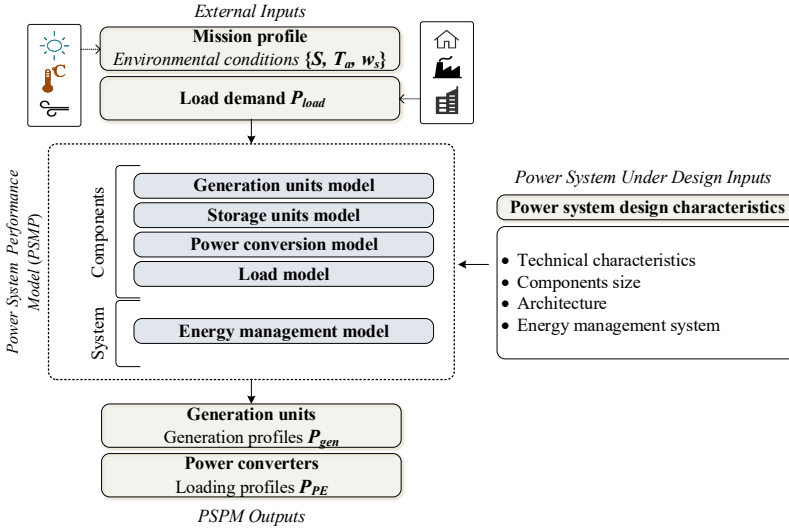

Fig. 2.2: Diagram of the Power System Performance Model (PSPM) used to determine the generation profiles and loading of power converters in the modern power system. Source: [C1].

model 4), respectively.

2.2.1 Power System Performance Model

A PSPM is developed to investigate the operating conditions of the power system for the planning horizon T_{PH} . To evaluate power system and power electronics reliability, several parameters need to be determined within PSPM, as indicated in Fig. 2.1. For example, generation P_{gen} and load P_{load} profiles of the system are required in the power system reliability analysis. Moreover, the loading profile P_{PE} of each power converter in the power system is necessary for the power electronics reliability study. To determine all of the aforementioned parameters (i.e., P_{gen} and P_{PE}), the component- and system-level models, as well as their interactions, are defined within PSPM and illustrated in Fig. 2.2. Various models with differences in the complexity and data requirements can be selected for that purpose. The system design characteristics (the external input to the model shown in Figs. 2.1 & 2.2) can serve as guidance in the selection process. Moreover, it is equally important to enable the investigation of the external impact, such as environmental conditions, through the selected models. In such a way, it is possible to analyse the effect of any power system dynamics on the reliability and cost results of the modern power system for the planning horizon T_{PH} .

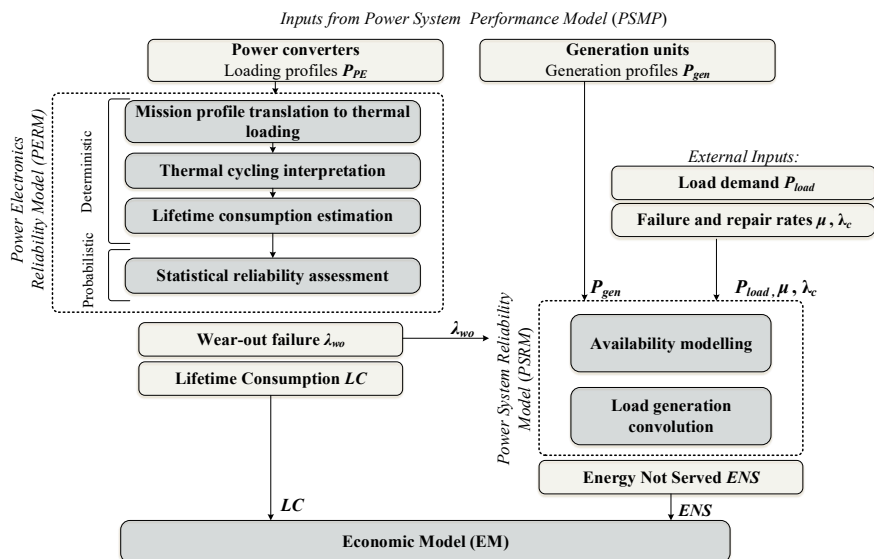

Fig. 2.3: Diagram of the Power Electronics Reliability Model (PERM) and Power System Reliability Model (PSRM). Source: [C1].

2.2.2 Reliability Models

The reliability models cover the two relevant aspects, i.e., power system reliability and power electronics reliability. In case of the power electronics reliability, it is necessary to determine the amount of lifetime consumed for each power converter in the power system. In such a way, it is possible to estimate when each power converter needs to be replaced due to failure. To determine the power converter lifetime consumption LC , the loading profiles P_{PE} evaluated during operation within PSPM are used. Once this parameter is available, it is used in EM for the power electronics reliability-related cost assessment. In addition, the wear-out failure rates λ_{wo} of the power converters are evaluated within the PERM model, as indicated in Fig. 2.1. This parameter is utilized in PSRM as a part of the system-level reliability analysis. There, the main aim is to determine a relevant reliability index which can be used in the economic assessment to account for the power system reliability-related costs. Both processes are outlined in Fig. 2.3, with specific details provided below.

PERM is based on the PoF approach to reliability modelling which is discussed in detail in [J1]. The process is based on several steps that need to be employed to determine LC , as indicated in Fig. 2.3. The loading of each power converter P_{PE} is translated into the stress profile of the reliability-critical components. In this work, junction temperature T_j represents, as a case, the stress parameter of the Insulated-Gate Bipolar Transistor (IGBT) that

2.2. Proposed Modelling Approach

is considered the reliability-critical component [90]. The junction temperature profile is determined utilizing an electro-thermal model, which maps electrical parameters into the thermal stress of the power converter [29]. Once the thermal profile is determined, lifetime consumption LC is estimated through the lifetime model of IGBT. In the case of irregular and dynamic thermal profiles, an intermediate step is enforced to decompose the profile into a simple set of reversals. To account for the uncertainties, a statistical reliability assessment is carried out. The outcome of this process is a reliability function of the IGBT sample set that accounts for parameter variations of the lifetime model [89], which can be used to determine λ_{wo} .

PSRM is defined to determine the amount of energy that is expected to be lost due to the power system unavailability. An adequate reliability index for such analysis is Energy Not Served ENS [83]. To determine this parameter, the availability modelling takes place, as shown in Fig. 2.3. The system unavailability is modelled based on the availability of the power converters in the system. For that purpose, repair μ and failure rates λ are needed. Repair rates μ and the constant failure rates λ_c , which account for the random chance failures can be obtained from the historical data or relevant reliability handbooks. Furthermore, the wear-out failure rates λ_{wo} of the power converters are obtained from the PERM. Once the availability of power converters is determined by following the method presented in [91], the capacity outage probability table is defined. This table provides information about the different power system states based on the availability of the power converters, the power generation, and the load profiles. Finally, a state enumeration method is employed to calculate ENS based on the provided table.

2.2.3 Economic Model

This model connects the conventional assessment of the power system cost i.e., capital cost and operation & maintenance (O&M) cost with two reliability aspects. Thus, the total cost C_{sys} of the modern power electronics-based power system is defined as:

$$C_{sys}(t) = C_{cap} + C_{o\&m}(t) + C_{rel}^{PE}(t) + C_{rel}^{PS}(t) \quad (2.1)$$

where C_{cap} and $C_{o\&m}$ are the capital cost and O&M cost of the system respectively, C_{rel}^{PE} is the power electronics reliability cost, and C_{rel}^{PS} is the power system reliability cost.

Capital cost C_{cap} includes the investment cost of the power system and its essential components. O&M cost $C_{o\&m}$ accounts for any cost that is necessary to keep the system at the desired level of operational performance [92]. Power electronics reliability cost C_{rel}^{PE} and power system reliability cost C_{rel}^{PS} are defined in (2.3) and (2.4) respectively by means of parameters evaluated in their respective models. C_{rel}^{PE} represents the cost of the power converter

replacement due to the ageing-related failure. It is determined through LC parameter, as indicated in Fig. 2.3. C_{rel}^{PS} represents the cost of energy delivered from the grid due to the power converter-related unavailability of the local load supply. It is determined through the ENS parameter provided by PSRM.

$$C_{PE_i}^{rep}(t) = \begin{cases} C_{PE_i}^{rep}, LC_i(t) = 1 \\ 0, \text{ otherwise} \end{cases} \quad (2.2)$$

$$C_{rel}^{PE}(t) = \sum_{i=1}^{N_{PE}} C_{PE_i}^{rep}(t), \text{ for } 1 < t < T_{PH} \quad (2.3)$$

$$C_{rel}^{PS}(t) = ENS \cdot C_{energy}(t), \text{ for } 1 < t < T_{PH} \quad (2.4)$$

where $C_{PE_i}^{rep}$ is the cost of replacement of i -th converter in the system and C_{energy} is the price per unit of energy delivered from the grid at instant t .

C_{energy} and other economic parameters necessary to evaluate the cost components need to be based on the recent industry reports. Furthermore, it is worth including any relevant changes in those parameters over the planning horizon T_{PH} . Such practice is especially important in case of the parameters which can heavily influence the final cost C_{sys} . In this analysis, it is concluded that C_{energy} is one such parameter, which value is projected to be increased in the future. Hence, its time dependence is modelled accordingly.

2.3 Case study: Reliability Impact on Power System Cost

2.3.1 Model Application to Power Electronics-Based Power System

The impact of the power electronics and the power system reliability cost is investigated for a small power electronics-based power system. It is commonly used in residential photovoltaic (PV) applications, with the configuration shown in Fig. 2.4. It consists of a single generator unit (PV arrays), an energy storage unit (battery) and a power conversion system that consists of the three power converter units. The PV converter is a uni-directional DC/DC boost converter, while the battery converter is a bi-directional DC/DC converter. Its operational principles are directly related to the battery operation (boost during battery discharge, buck during battery charge). To transfer

2.3. Case study: Reliability Impact on Power System Cost

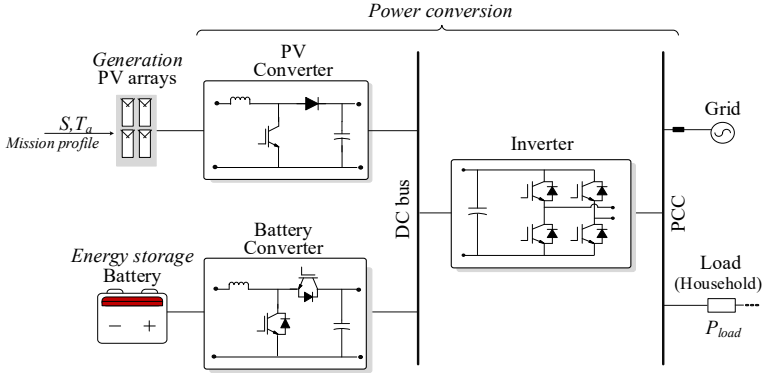

Fig. 2.4: Configuration of a power electronics-based power system under study. Source: [C1].

Table 2.1: Technical design characteristics of the power electronics-based power system under study. Source: [C1].

Parameter	Value
PV arrays nominal power	6 kW
PV converter rated power	6 kW (3 kW x 2 units)
Battery nominal power and energy capacity	3 kW/3.5 kWh
Battery converter rated power	3 kW
Inverter rated power	6 kW
Energy management strategy	Self-consumption
Reliability-critical component	IGBT
Planning horizon	25 years

power to the AC side (grid and the local load), a full-bridge single-phase inverter with four active switches is chosen. Detailed descriptions and relevant parameters are provided in [C1], while the summary is provided in Table 2.1.

The components of the system are modelled within the PSPM block shown in Fig. 2.2. For the generation unit, an electrical characteristic model of a PV panel is used [93]. It provides information about the maximum power point and voltage for input environmental conditions (solar irradiance S and ambient temperature T_a). The environmental conditions are represented through the time-series data, i.e., mission profiles at the installation site. Furthermore, the battery unit is modelled through the Coulomb counting method to estimate the state-of-charge for a given input power [94]. The load is represented by a load demand profile, which shows the power needs of a household connected to the PV-battery system. The energy management strategy of the system is based on the self-consumption principles. In such a case, the in-

Table 2.2: Economic parameters of the Economic Model (EM) used in the study of the power electronics-based power system. Source: [C1].

Parameter	Value	Description
C_{cap}^{gen}	1550 USD/kW	PV component of the capital cost
$C_{o\&m}(t)$	14 USD/kW yearly	PV component of the O&M cost
$C_{cap}^{storage}$	400 USD/kWh	Battery component of the capital cost
$C_{o\&m}(t)$	7 USD/kWh yearly	Battery component of the O&M cost
$C_{PE_i}^{rep}$	250 USD/kW	Power electronics replacement cost
C_{grid}	0.32 USD/kWh	Grid electricity reference cost

ternal power supply is prioritized, while the excess energy if not stored in the battery, can be fed into the grid. If the generation or storage unit cannot supply the load, the energy is provided from the grid.

To evaluate the lifetime consumption LC of each converter, a lifetime model described in [87] is incorporated into the PERM. The failure rates, which account for the random chance failures as well as the repair rates, are based on [28]. The economic parameters are based on the investigation of the industry trends in PV applications, where more details can be found in [C1]. The summary of the main economic parameters is provided in Table 2.2. In addition, the system is planned for an operational span of 25 years, i.e., $T_{PH} = 25$ years.

2.3.2 Power Electronics Reliability Cost

To understand the power electronics reliability cost C_{rel}^{PE} , the results of the PERM shown in Fig. 2.5(a) are analysed. The results indicate that both inverter and battery converter reach their end-of-life due to wear-out before T_{PH} is reached. In fact, the inverter needs to be replaced after 56% of the planning horizon (14 years), while battery converter replacement takes place one year before T_{PH} is reached. Thus, the power converter units need to be replaced twice during the operation. While the power converter design dictates its reliability, it is worth mentioning which main parameters within the PSPM in Fig. 2.2 influence LC progression. Such information is vital when analysing the full extent of the power electronics reliability cost C_{rel}^{PE} implications for the power electronics-based power system design. For example, the inverter lifetime is significantly shorter due to the energy management strategy of the system. The chosen strategy requires a large amount of energy transfer through the inverter, i.e., from both the generation unit and the storage unit towards the load and the grid. Such energy management prin-

2.3. Case study: Reliability Impact on Power System Cost

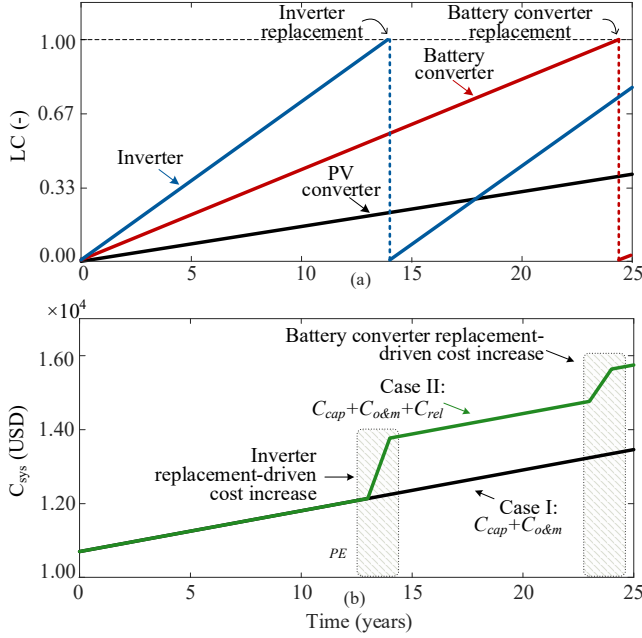

Fig. 2.5: Power electronics reliability-related results (see Fig. 2.4): (a) Lifetime consumption LC of the converter components, and (b) System cost C_{sys} for Case I (without power electronics reliability considerations) and Case II (with included power electronics reliability cost). Source: [C1].

principles cause extensive stress in the inverter unit, which, in turn, results in an accelerated lifetime consumption LC . Another important aspect is the size of the system, which influence is observed in the case of the battery converter lifetime. The PV array size impacts the excess power production, while battery power rating characterizes the battery energy cycling, which defines the battery converter loading profile.

The replacements of the inverter and the battery converter units directly affect the cost of the system C_{sys} , as indicated in Fig. 2.5(b). In fact, it is observed that the power electronics reliability cost C_{rel}^{PE} accounts for the significant increase in the overall system cost C_{sys} . This impact is also seen in the C_{sys} at the end of the operational span (indicated as Case II in Fig. 2.5(b)) compared to the base case consisting of only capital and O&M cost (indicated as Case I in Fig. 2.5(b)). C_{rel}^{PE} is characterized by a steep increase in the system cost C_{sys} in the years the power electronics replacement takes place. The time when this cost occurs is directly dependent on the reliability level for which the power converters are designed. Given the fact that this cost accounts for a large increase in specific years, it is pivotal to assess the lifetime of the power converters accurately. It is equally vital to include this cost component in

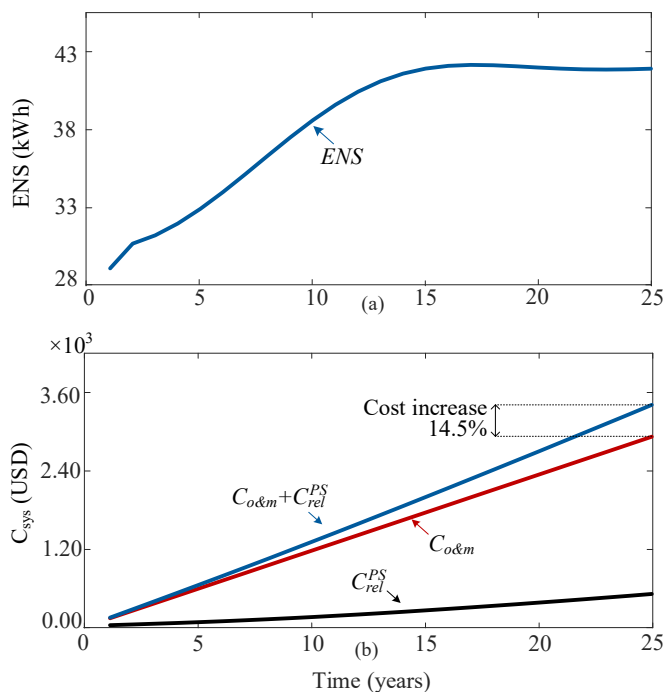

Fig. 2.6: Power system reliability-related case study results (see Fig. 2.4): (a) Energy not served ENS , and (b) Cost of power system reliability C_{rel}^{PS} and O&M cost $C_{o\&m}$. Source: [C1].

the economic assessment of the modern power system being planned, as it is shown that significantly influences the final cost value. Not doing so can have large repercussions, as it can impact the optimal system design solution of the techno-economic analysis.

2.3.3 Power System Reliability Cost

Power system reliability cost C_{rel}^{PE} is related to the reliability index ENS , which is shown in Fig. 2.6(a). The results indicate that the value of this index gradually increases over time. Two parameters influence such results, namely electricity price C_{grid} and failure rates of the converters λ_{wo} . The former is an external factor, which is defined to realistically project future conditions. The latter are the direct results of the reliability modelling within the PERM and PSRM. ENS value increases over time as a result of the ageing of power converters, which is accounted for through the wear-out failure. Thus, a higher amount of energy is expected to be lost due to power electronics ageing-related vulnerabilities. A substantially smaller increase in ENS is observed after the inverter replacement takes place (indicated in Fig.2.5(a)). There, the

2.3. Case study: Reliability Impact on Power System Cost

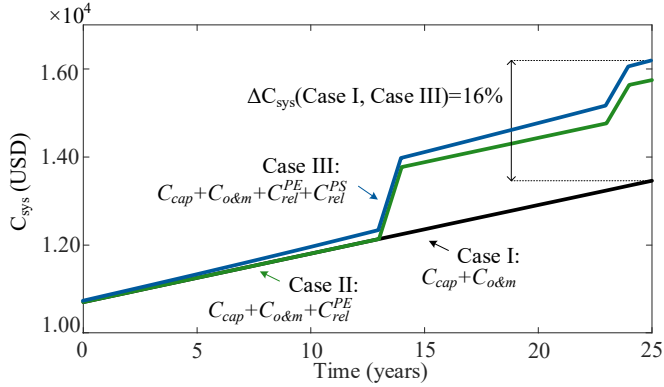

Fig. 2.7: Case study results of the system in Fig. 2.4: System cost C_{sys} for Case I (only capital cost and O&M cost considered), Case II (with included power electronics reliability cost), and Case III (with included both power electronics reliability and power system reliability cost). Source: [C1].

wear-out failure has an insignificant impact on the expected amount of lost energy. In addition, similarly to the power electronics reliability cost C_{rel}^{PE} , the power system reliability cost C_{rel}^{PS} is also highly influenced by the reliability level for which the power converters are designed.

Given the fact that the nature of the ENS parameter differs from LC , the power system reliability cost is compared only with the O&M cost. Both costs account for the total system cost C_{sys} yearly and gradually increase over time. In Fig. 2.6(b), it is shown that power system reliability cost results in an increase of 14.5% of O&M cost at the end of the planning horizon T_{PH} . It is, further on, assumed that this cost can be even more significant if more power converters are present in the system. Thus, it is important to be assessed and included in the cost assessment.

Finally, to characterize the total system cost with included power electronics reliability cost and power system reliability cost, results in Fig. 2.7 are shown. There, three cases are indicated, namely Case I which only includes commonly used capital and O&M cost. Moreover, power electronics reliability cost is added in Case II, while power system reliability cost is added in Case III. The results indicate 16% higher C_{sys} of Case III. Therefore, this case study confirms that the two reliability aspects impact the profitability of the system under design. The models and the methodology presented in this chapter can be used to assess such impact. Furthermore, they can be utilized to assess the impact of different external parameters and operational principles on the reliability results and, consequently, the profitability of the modern power electronics-based power system.

2.4 Summary

In this chapter, a model for cost and reliability studies of a power system with a high installation rate of power electronics is developed. The model is formed to account for both power electronics and power system reliability and cost for planning horizon. For that purpose, different aspects of the model are evaluated, such as the power system performance, lifetime, reliability, and cost. Moreover, a connection between the different aspects is established and the influence of the external parameters related to each aspect is included. The developed model is employed in the analysis of the power electronics-based power system. The results of the analysis suggest that both power electronics reliability and power system reliability impact the overall cost of the power electronics-based power system. In fact, it is shown that the cost of the system can be significantly underestimated when the two reliability aspects are not considered. Furthermore, the nature of the two costs are analysed and it is determined that they impact the system cost in different manners. For example, power electronics reliability cost accounts for large amounts only in specific years when the replacement of the power converter takes place. In contrary to this, power system reliability cost is accounted for yearly and contributes to the overall system cost gradually. The results of the analysis can be used for optimal and cost-effective planning of the power electronics-based power system.

Related Publications

- J1. M. Sandelic, S. Peyghami, A. Sangwongwanich, and F. Blaabjerg, "Reliability aspects in microgrid design and planning: Status and power electronics-induced challenges," *Renew. Sust. Energ. Rev.*, vol. 159, pp. 112127-112143, May 2022.**

Main contribution:

This paper reviews the main power electronics-induced challenges in the power system. A detailed analysis of the state-of-the-art provides an insight into the main challenges that obstruct a comprehensive assessment of mutual power electronics and power system characteristics on the cost of modern power systems under design.

- C1. M. Sandelic, A. Davoodi, A. Sangwongwanich, S. Peyghami and F. Blaabjerg, "Multi-Converter System Modelling in Cost for Reliability Studies," in *2021 IEEE 22nd Workshop on Control and Modelling of Power Electronics (COMPEL)*, Cartagena, Colombia, 2021, pp. 1-8.**

2.4. Summary

Main contribution:

In this paper, a comprehensive model that connects performance, reliability and cost aspects of the system is defined. The developed model is intended to be used in the power electronics-based power system. In this paper, it is employed for the analysis of the power electronics and power system reliability impact on the overall system cost.

Chapter 3

Long-Term Generation Forecasting for Enabling Power Electronics-Based Power System Planning

3.1 Background

During the planning of a traditional power system, the forecasting of the generation and load demand takes place for several decades ahead [95]. The forecasting profiles are used to determine the optimum size of the units in the power system [51, 96]. Such profiles are characterized by a low temporal granularity and a long-term horizon, as illustrated in Fig. 3.1. When a modern power electronics-based power system should be planned, the forecast profiles would have an additional purpose. They would also be used for the reliability prediction of the failure-prone power electronics. This is an important task which can help in avoiding any power electronics-related unforeseen power outages and unplanned maintenance activities. In addition, it can help in estimating the power electronics reliability cost realistically, which has been shown in *Chapter 2* to have a significant impact on the power system design. However, the profile requirements for this prediction differ significantly. In Fig. 3.1, it is shown that power electronics reliability-related studies require profiles with a high temporal granularity over several years. For those profiles, it is pivotal that the relatively fast dynamics (e.g., in the range of minutes), which can have a deteriorating effect on power electronics lifetime [97], are captured. In such cases, the long-term forecasting of

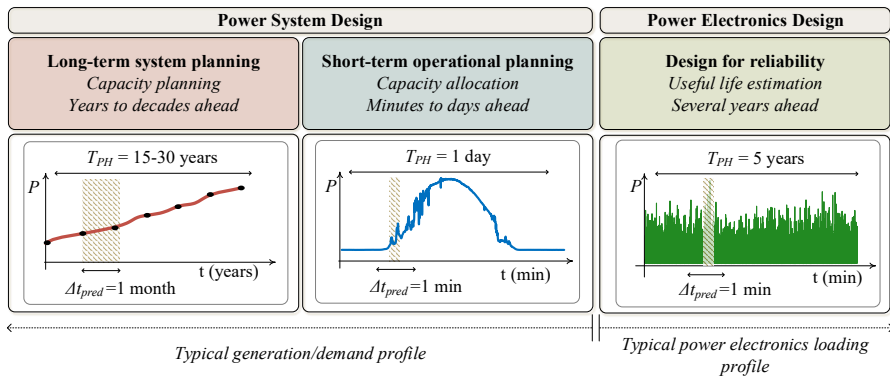

Fig. 3.1: An overview of the forecast profile P characteristics (temporal granularity or time resolution Δt_{pred} and prediction horizon T_{PH}) in the power system and power electronics design applications. Source: [C2].

the traditional power system cannot be directly applied to the modern power electronics-based power system, as discussed in detail in [C2]. Therefore, this chapter is devoted to developing a method for long-term forecasting which enables power electronics reliability investigation within the long-term power system planning based on [J2]. To fully describe the method, an additional focus will be put on investigating its performance, accuracy, and robustness.

3.2 Proposed Forecasting Methodology

The proposed framework for long-term forecasting suitable for the power electronics-based power system design is shown in Fig. 3.2. The framework is based on the idea that the historical mission profiles are analysed and used to train a forecasting model. This forecasting model is then used for predicting mission profiles which can also be used for power electronics reliability purposes. The methodology is developed on the example of a single converter in the solar photovoltaic application shown in Fig. 2.4 with the parameters in Table 2.1 in Chapter 2. Moreover, the methodology is applied to the forecasting of the solar irradiance S and ambient temperature T_a profiles (i.e., mission profile) which define the PV power generation and the PV converter loading and reliability.

The training process is defined around the concept that the historical mission profile can be transformed into a simplified mission profile. Such a simplified profile is a combination of only several representative daily profiles. During the transformation process, it is assured that the simplified profile gives the same power electronics reliability as the historical mission profile. In the subsequent stage, the forecasting of the future mission profiles

3.2. Proposed Forecasting Methodology

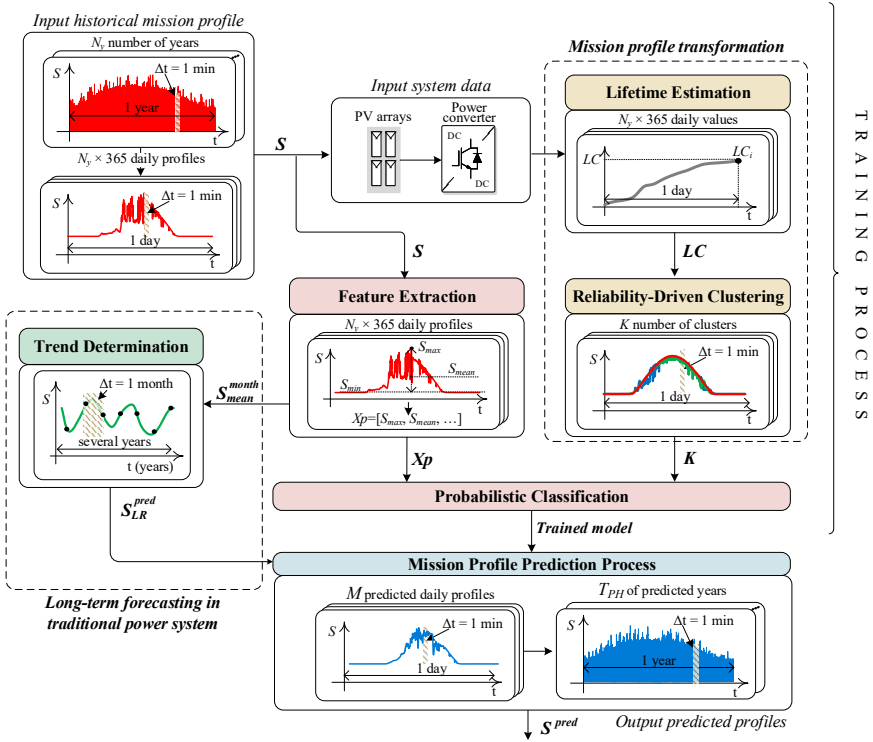

Fig. 3.2: Framework for the long-term forecasting of the power electronics-based power system. Solar irradiance S is taken as an example of the historical mission profile for a power converter connected to the PV arrays. The framework results with S^{pred} predicted mission profile suitable for power electronics reliability investigation within the long-term modern power system planning. Source: [J2].

is done by predicting a series of representative daily profiles based on the trained model. The result of the whole process is the forecast profile which, similarly to the transformed mission profile during training, is a combination of several representative daily profiles. Such predicted profile has the temporal granularity and the prediction horizon which are suitable for power electronics reliability investigation (as illustrated in Fig. 3.1).

To transform the historical mission profile into a simplified mission profile, several steps need to be employed, as marked in Fig. 3.2. First, in the Lifetime Estimation block, LC of the power converter is determined for each day of the historical mission profile. In the following step, K number of representative days is defined within the Reliability-Driven Clustering block. The model is trained in the Probabilistic Classification block, which requires the representative days as well as the features of each daily profile X_p in the historical mission profile. There, for each daily profile in the historical mission profile, the relationship between its features and the representative day

decided within the Reliability-Driven Clustering block is examined [98,99]. The features are defined in the parallel process within the Feature Extraction block. They include temporal and environmental characteristics, such as mean and maximum daily value, mean weekly value, etc. One important feature in X_p is the mean monthly value S_{mean}^{month} . This value is used in the Trend Determination block, which contains a separate model for forecasting profiles with a low temporal granularity S_{LR}^{pred} (as illustrated in Fig. 3.1). It represents the long-term forecasting model utilized in traditional power system planning. It is included in the proposed model to showcase how the forecasting for power electronics and power systems can be done in synergy within one procedure.

The main part of the proposed forecasting model is Reliability-Driven Clustering, which assures that the simplified forecast mission profile can be used to accurately predict the power electronics reliability. Its working principle is described in detail in the following.

3.2.1 Reliability-Driven Clustering

The Reliability-Driven Clustering block in Fig. 3.2 is designed under consideration that all the daily profiles that have a similar impact on the power converter reliability are grouped into one cluster [100]. Thus, the whole historical mission profile can be divided into K groups, namely clusters. Furthermore, each cluster is assigned a cluster centroid C_k , which best describes the impact of the cluster elements on the power electronics reliability. Each daily profile of the historical mission profile can be represented with its C_k . Essentially, this results in a simplified historical mission profile that only consists of K different daily profiles. Simultaneously, due to the reliability-driven clustering, no significant error is introduced in the power converter reliability estimation when such a simplified historical mission profile is used.

To divide the elements into clusters, a variety of commonly known clustering methods can be applied [100]. They usually employ an iterative process to define C_k values and optimally attribute elements to the clusters based on their mutual distances. This process is shown in Fig. 3.3, where it is indicated as Initial elements division. However, such methods have inherent limitations, which result in clusters that cannot meet the requirements for an accurate power electronics reliability estimation [C3]. One such limitation is the lack of flexibility, where all the elements are divided into the pre-defined number of clusters K based on the division criterion which does not reflect any power electronics reliability-related characteristics. Such features disable the dynamic adjustment of the clusters and their elements to meet the specific reliability requirements.

Therefore, the proposed reliability-driven clustering process implements an additional layer, as shown in Fig. 3.3, namely the Reliability-based reshaping

3.2. Proposed Forecasting Methodology

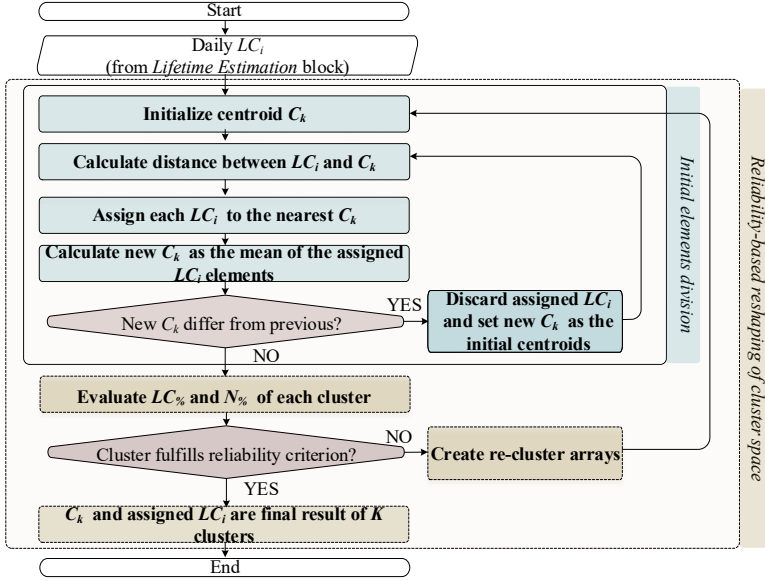

Fig. 3.3: Flow chart of the proposed reliability-driven clustering of mission profile within the proposed forecasting procedure. It is based on Initial elements division, followed by Reliability-based reshaping of the cluster space. Source: [J2].

ing of cluster space. In fact, it assures that the final number of clusters and the elements that belong to each cluster facilitate the accurate power electronics reliability estimation. For example, it is assured that the clusters with a high power electronics reliability impact are homogeneous. This refers to that the discrepancy between LC contribution of the cluster elements and its centroid C_k is insignificant. In fact, the cluster homogeneity rate can be measured by evaluating the percentage of its mean that equals its three standard deviations 3σ . Thus, the lower the percentage, the higher the homogeneity of the cluster is assured. In this layer, all of the high-impact clusters which do not adhere to the homogeneity criterion are subjected to re-clustering. As a result, the initial high-impact clusters are divided into homogeneous sub-clusters.

Reliability-based reshaping of clustering space is implemented by examining the two relevant parameters of each cluster, i.e., the number of elements and LC contribution. In the case of the former, the percentage of the k -th cluster elements in the overall number of elements is examined and denoted with $N_{\%}(k)$. Relevant to later, the percentage of the k -th cluster LC in the cumulative LC of all elements (i.e., historical mission profile) of the power converter is evaluated and denoted with $LC_{\%}(k)$. A high or a low value of the two parameters indicates how homogeneous the clusters need to be. The clusters with a high $LC_{\%}(k)$ need to have a high level of homogeneity due to their direct impact on the power electronics reliability. This is shown on the

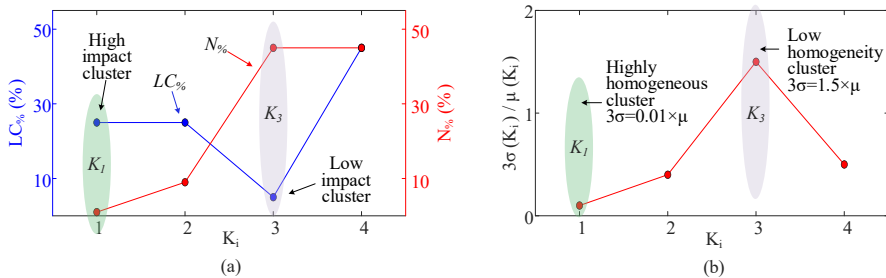

Fig. 3.4: Example of results used during reliability-based reshaping of cluster space within the proposed reliability-driven clustering procedure: (a) cluster impact examined through $LC_{\%}$ and N_k parameters, and (b) cluster homogeneity rate. Source: [J2].

example of cluster K_1 in Fig. 3.4. Moreover, any clusters with similar $N_{\%}(k)$ and $LC_{\%}(k)$ values which are not homogeneous would need to be subjected to the re-clustering. Simultaneously, the reliability-based reshaping of the clustering space assures that the low-impact clusters are not further divided into sub-clusters. One such example is cluster K_3 , which has a large number of elements (i.e., high $N_{\%}(k)$ value) that only contribute to an insignificant portion of the overall LC (observed with a low $LC_{\%}(k)$) of the power converter. The cluster has a low homogeneity, but due to its low contribution to power converter lifetime consumption, it does not need to be further divided into sub-clusters. Such actions would otherwise be of no merit for the power electronics reliability prediction, and would only increase the complexity of the forecasting problem.

3.2.2 Prediction Process

Mission profile prediction process is illustrated in Fig. 3.5. Its working principle is based on the construction of the long-term mission profile from the series of the predicted daily profiles. The process of daily profile prediction is done in two steps, which are indicated in Fig. 3.5 as Probabilistic Forecast and Prediction Profile Attribution. In the first step, the cluster K^{pred} of the daily profile is predicted through the trained forecast model (Fig. 3.2). Afterwards, a daily profile corresponding to the predicted cluster is attributed S^{pred} . This two-step process is repeated until the prediction horizon T_{PH} is reached. In the subsequent phase, the output long-term forecast profile with a high temporal granularity is assembled.

To predict the daily profile cluster K^{pred} with the trained model, the set of features X_p that describe the preceding predicted daily profile needs to be known. This is determined within the Data Characterization block shown in Fig. 3.5. There, the last predicted cluster K^{pred} is used to define the feature vector X_p . This is done by examining the training data, where all the daily

3.3. Performance of Reliability-Driven Clustering

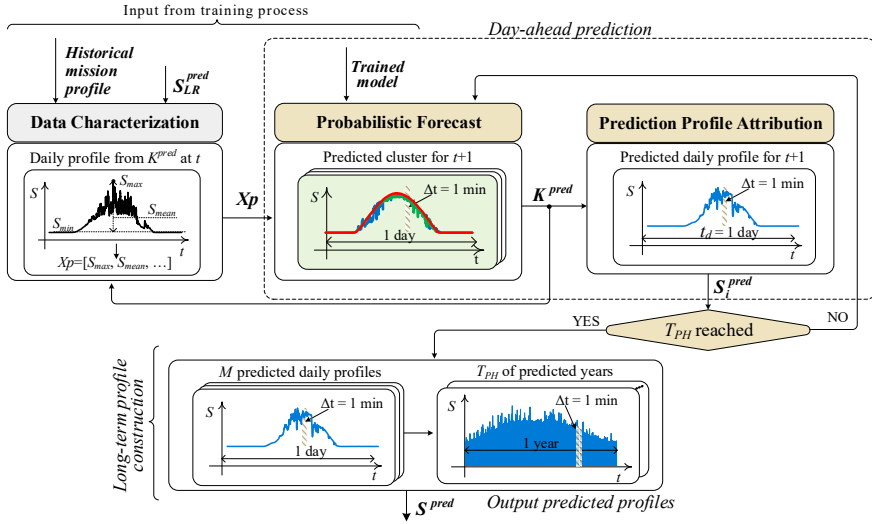

Fig. 3.5: Diagram of the prediction process within the proposed long-term forecasting method. The process is based on the iterative day ahead prediction of solar irradiance S_i^{pred} . The output profile S^{pred} is constructed of M daily profiles and it is suitable for power electronics reliability investigation within long-term modern power system planning. Source: [J2].

profiles that belong to the predicted cluster are provided. The feature vector is defined by randomly selecting a daily profile with the same calendar attribute as the last predicted profile S_i^{pred} . In addition, similarly to the training process illustrated in Fig. 3.2, an average monthly value of the prediction variable S_{LR}^{pred} is added to the feature vector X_p . S_{LR}^{pred} is a commonly available parameter during the long-term planning of a traditional power system, while it is used in this process to further aid the prediction accuracy. This parameter is obtained from Trend Determination block in the training process shown in Fig. 3.2.

3.3 Performance of Reliability-Driven Clustering

An adequate clustering is one of the critical parts of the proposed procedure (shown in Fig. 3.2) that can assure a forecasting accuracy for power electronics reliability prediction. Thus, the performance of both Initial elements division and Reliability-based reshaping of cluster space within the clustering procedure are examined on the example of a one-year mission profile.

When examining the performance of the Initial elements division process, it is necessary to evaluate whether there are any significant overlapping among the clusters for certain combinations of values in the feature vector

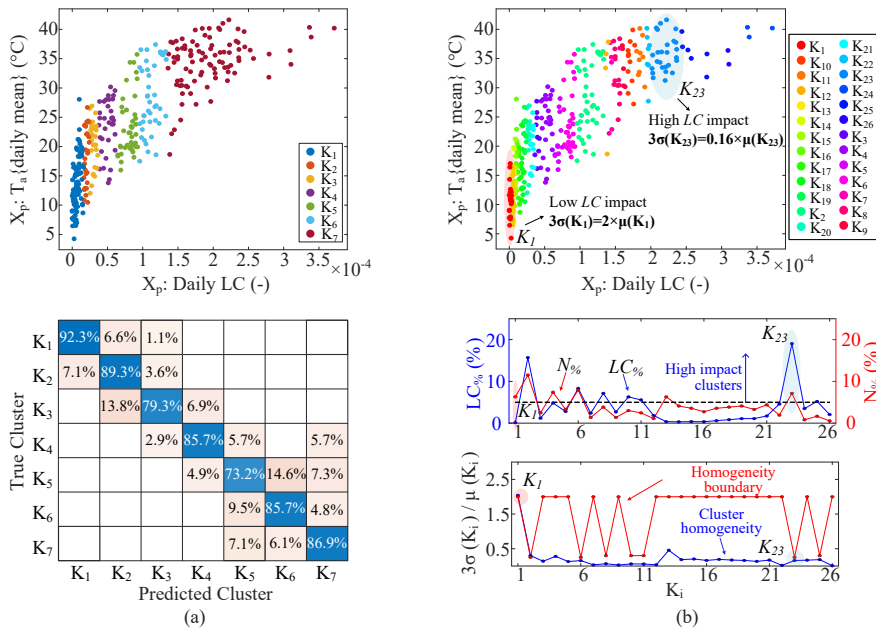

Fig. 3.6: Performance results of the proposed reliability-driven clustering performed for the power converter connected to the PV arrays shown in Fig. 3.2: (a) Clustering results for the Initial elements division and probabilistic classification results, and (b) Results of the Reliability-based reshaping of clustering space with indicated cluster impact and homogeneity levels. Source: [J2].

X_p . When clusters do not overlap, it means that each cluster has a specific value of X_p parameters. This characteristic is important in the classification and prediction process, where the exact cluster can be determined based on the given set of features. In the case of the feature values which would share two or more clusters, errors in the prediction process could occur. In such a case, it would become profoundly difficult to identify the actual cluster among the ones with similar features. The results indicated in Fig. 3.6(a) show no overlapping of the clusters. Moreover, good clustering performance is reflected in a high level of accurate cluster prediction (more than 85%) in the classification process.

To examine if the clusters are adhering to the reliability requirements, the results of Reliability-based reshaping of cluster space are examined and shown in Fig. 3.6(b). For the high-impact clusters, it is necessary to examine if they are divided into sub-clusters with an adequate homogeneity level. The results in Fig. 3.6(a) indicate that cluster K_7 is a high-impact cluster, which covers a large area of the feature combinations (i.e., low level of homogeneity). Thus, this cluster is divided into several high-impact homogeneous sub-clusters, as indicated in Fig. 3.6(b). Furthermore, in the case of

3.4. Forecast Accuracy

low-impact clusters, it is relevant to investigate if they remain intact without any unnecessary sub-divisions. The clusters with low LC contribution of the power converter (e.g., K_1 , K_{13} provided in Fig. 3.6(b)) show large deviations among the LC value of their elements (low homogeneity). However, $LC_{\%}$ and $N_{\%}$ parameters indicate that those clusters do not need to be further divided into sub-clusters, as their impact on the overall LC of the power converter (see Fig. 3.2) is insignificant. Therefore, both reliability-related clustering requirements of this layer are fulfilled. In addition, the clustering performance of the proposed procedure is at a satisfactory level, as no evident overlapping of the resulting clusters is observed.

3.4 Forecast Accuracy

The accuracy of the probabilistic forecast is evaluated for a model trained with a historical mission profile lasting nine years with 1 minute per sample resolution. The predicted mission profiles are shown in Fig. 3.7 for the prediction horizon T_{PH} of one year and six years. The results indicate that the predicted profiles do not have a high level of point-to-point matching with the actual profiles. Such results are expected, as the predicted profile is a simplified profile that consists of a combination of only several different daily profiles. However, the point-to-point matching of the mission profiles does not reflect the accuracy requirements, as those profiles are further used for power converter reliability evaluation. Thus, to examine the forecast ac-

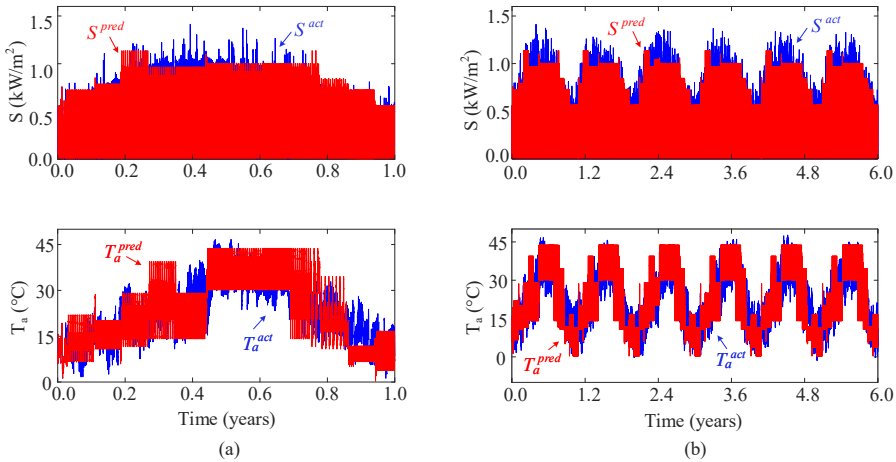

Fig. 3.7: Predicted mission profiles of solar irradiance S^{pred} and ambient temperature T_a^{pred} obtained with the proposed long-term forecasting model for a prediction horizon: (a) $T_{PH} = 1$ year, and (b) $T_{PH} = 6$ years. Source: [J2].

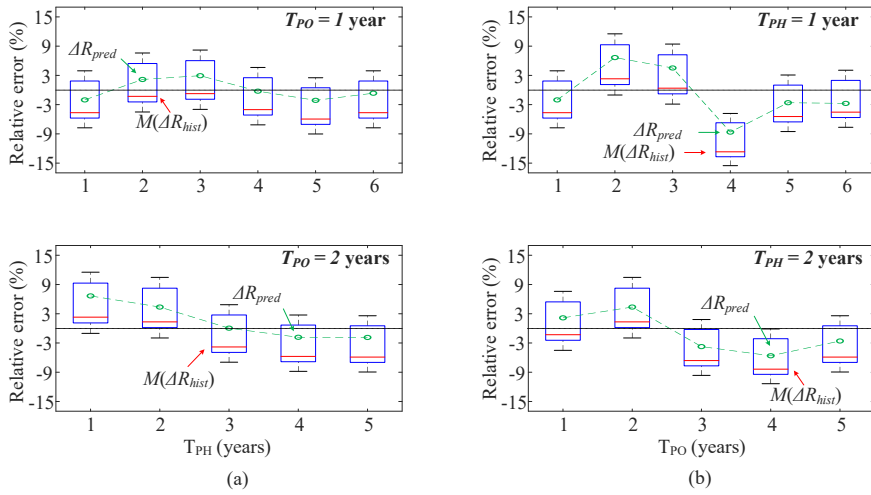

Fig. 3.8: Forecasting accuracy of the proposed forecasting method with relative error in the lifetime consumption of power converter based on the predicted environmental conditions ΔR_{pred} and historical profiles ΔR_{hist} (shown as a box plot) for varying: (a) Prediction horizons T_{PH} , and (b) Prediction offsets T_{PO} . Source: [J2].

curacy, it is necessary to evaluate the relative difference in LC of the power converter obtained for the input predicted profiles LC^{pred} and the actual profiles LC^{act} :

$$\Delta R_{pred} = \frac{LC^{pred} - LC^{act}}{LC^{act}} \times 100\% \quad (3.1)$$

This assessment yields ΔR_{pred} of -2.08% for T_{PH} of 1 year. The negative value of the ΔR_{pred} parameter indicates that LC^{pred} obtained with the predicted mission profile (S^{pred}, T_a^{pred}) results in an under-estimated LC of the power converter, compared to the actual profile. Moreover, an insignificant increase of ΔR_{pred} is observed with the extension of the prediction horizon T_{PH} to six years. This reflects that the lifetime of the power converter will be predicted longer than the actual lifetime by an insignificant margin.

Even though the obtained results seem to provide an accurate estimation of the power electronics lifetime, a more detailed analysis is carried out to validate the accuracy of the proposed model. For that purpose, the accuracy of the predicted LC is compared with the state-of-the-art approach [55]. There, one-year historical data is used to evaluate LC . It is, further on, assumed that the accumulation of one-year damage is linear until the end-of-life is reached. This approach is applied to the training data sets, where LC of each year is calculated and considered as a separate test case. The relative error between each case and the actual LC ΔR_{hist} is determined and compared to the relative error that involves the predicted profiles ΔR_{pred} . Moreover, the influence of

3.5. Influence of Data Availability on Forecasting Results

the prediction horizon T_{PH} and prediction offset T_{PO} is analysed and shown in Fig. 3.8. The results indicate that ΔR_{pred} is lower than the median of the relative error of the historical results $M(\Delta R_{hist})$ for the majority of the cases and combinations of T_{PH} and T_{PO} . Moreover, the state-of-the-art method of reliability prediction shows deteriorating results for the extension of the prediction horizon T_{PH} . In such a case, the proposed method outperforms the state-of-the-art method, as the randomness of the historical profiles becomes more pronounced.

Thus, the analysis suggests that the proposed method shows both a sufficient accuracy in the reliability prediction and a better performance than the state-of-the-art methods. It is also shown that the proposed method overcomes the limitation of the long-term forecast methods for the prediction of the high-resolution profiles. Furthermore, the proposed method enables accurate forecasting of the profiles that can be used for long-term sizing of the modern power system with included power electronics reliability in the decision-making process.

3.5 Influence of Data Availability on Forecasting Results

Given the fact that the proposed method is data-driven, it is necessary to evaluate its sensitivity to data availability. To quantify its relation to the prediction accuracy, six scenarios are defined and shown in Table 3.1. The proposed framework in Fig. 3.2 is employed to train the forecast model based on the historical mission profile with removed data for each of the defined scenarios. The reliability results are compared to the results in Fig. 3.8 for prediction horizon $T_{PH} = 6$ and prediction offset $T_{PH} = 1$.

In Fig. 3.9(a), the influence of data unavailability on the definition of the features in a feature vector X_p is illustrated. For the daily (Scenario I) and

Table 3.1: Overview of the scenarios with varying frequency and duration of missing data in the historical mission profile used in the robustness analysis of the proposed long-term forecast model. Source: [J2].

Scenario	Data removed N_{DR} Frequency (until T_{PH} is reached)	Data removed N_{DR} Duration for each iteration
I	every month	1 day
II	every month	1 week
III	every second month	1 week
IV	every fourth month	1 week
V	one winter month in a year	1 week
VI	one summer month in a year	1 week

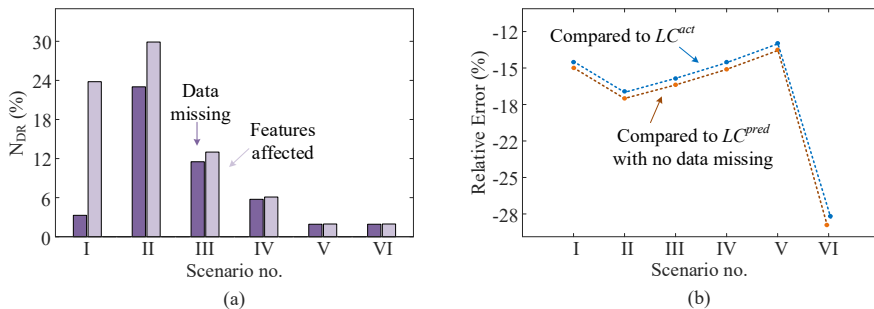

Fig. 3.9: Influence of data availability on forecasting results: (a) Percentage of missing data in the historical mission profile and their impact on the definition of features X_p , and (b) Relative error in the prediction of the lifetime consumption of the power converter connected to the PV arrays shown in Fig. 3.2 for a varying frequency and duration of missing data in the historical mission profile. Source: [J2].

weekly (Scenario II) duration of missing data, no significant difference in the affected features is observed. In fact, even though Scenario I accounts for a considerably smaller number of data points missing, the impact on the feature definition and, subsequently, the forecast model is significant. Thus, the X_p definition is equally affected for a varying duration of the data removed when their frequency is the same. On the contrary, the smallest discrepancy in removed data and affected features is observed for Scenario V and Scenario VI. There, the frequency of data unavailability is low enough not to affect the definition of the features.

The accuracy of the LC prediction for each scenario is shown in Fig. 3.9(b). All of the scenarios result in a large relative error, with a significant underestimation of the power converter LC . This refers to that the performance of the proposed framework is influenced when a significant data unavailability is present. However, a difference in the sensitivity level is observed, which can serve to analyse the type of data unavailability that is performance-critical. A comparison of the relative error of Scenario I and Scenario IV reveals that the impact of the consecutive data unavailability sets is not high for a reduced frequency of occurrence. On the contrary, the results of Scenario VI indicate that the nature of the data that is unavailable has an immense impact on model performance. For example, the unavailable data in Scenario VI cover daily profiles which result in the largest yearly LC contribution. Hence, it is of pivotal importance to have such data available in the training process.

3.6 Summary

In this chapter, a data-driven framework for long-term forecasting in the power electronics-based power system is presented. The framework enables

3.6. Summary

simultaneous forecasting of the traditional long-term profiles for generation capacity planning and mission profiles for power electronics reliability estimation. The working principle is based on grouping the historical data based on their impact on power converter reliability. The output profiles of the framework can be used in the long-term power system planning to, among others, optimally size the generation and storage units as well as the connecting power electronics. The proposed framework is tested in simulations for performance, accuracy and robustness. The performance results show a satisfactory level of each model employed during the training process within the forecasting framework. Furthermore, the analysis results show that the accuracy of power electronics reliability prediction is higher than the state-of-the-art approach, especially for extended prediction horizons. Finally, robustness results provide insight into the impact of the data availability on the forecast accuracy. The comprehensive results of the analysis can be used as guidance for the application of the forecasting framework in long-term modern power system planning.

Related Publications

- J2. **M. Sandelic**, Y. Zhang, S. Peyghami, A. Sangwongwanich, and F. Blaabjerg, "Reliability-Driven Clustering Methodology for Probabilistic Forecast of Environmental Conditions in Power Electronics Applications," *Int. J. Electr. Power Energy Syst.*, Status: Under Review.

Main contribution:

This paper presents a reliability-driven clustering methodology for the long-term forecast of power electronics-based power systems. The proposed clustering procedure enables mission profile clustering concerning their impact on the reliability of power converters. The prediction accuracy is compared to the state-of-the-art approach to mission profile-based reliability assessment. Moreover, the impact of data availability on the forecasting results is analysed.

- C2. **M. Sandelic**, Y. Zhang, S. Peyghami, A. Sangwongwanich and F. Blaabjerg, "Long-Term Forecasting Method for Power Electronics-Based System Design," in *2022 17th International Conference on Probabilistic Methods Applied to Power Systems (PMAPS)*, Manchester, United Kingdom, 2022, pp. 1-6.

Main contribution:

This paper addresses the need to develop a long-term forecasting method which is suitable for modern power electronics-based power system design. Concerning that, a forecasting method, which can be used to simultaneously

predict mission profiles for generation capacity planning and power electronics reliability prediction, is developed.

- C3. **M. Sandelic**, A. Sangwongwanich, S. Peyghami and F. Blaabjerg, "Reliability Modelling of Power Electronics with Mission Profile Forecasting for Long-Term Planning," in *2022 IEEE 13th International Symposium on Power Electronics for Distributed Generation Systems (PEDG)*, Kiel, Germany, 2022, pp. 1-6.

Main contribution:

In this paper, a framework for mission profile forecasting in the reliability modelling of power electronics is defined. The framework includes the power electronics reliability in the forecasting process.

Chapter 4

Integration of Power Converters Reliability into Long-Term Power System Sizing

4.1 Background

The pivotal task of long-term power system planning is the process of generation capacity planning [96,101]. This entails the decision on the optimum size, deployment time and technology mix of the generation and storage units over a long-term planning horizon [102,103]. However, in the modern power system, the requirement to include power electronics in this procedure becomes more and more pronounced. Therefore, this chapter is dedicated to investigating the long-term sizing of the modern power electronics-based power system. Similar to the long-term forecasting approach in *Chapter 3*, a procedure that enables the investigation of the power electronics reliability in the long-term sizing is developed.

Concerning that, this chapter is organized into two parts, where in the first part, a single-generator power system is considered. There, a detailed analysis of the various power electronics impacts on the power system planning is carried out. Furthermore, a study of the external inputs on the power electronics reliability is conducted. It provides a more detailed description of the power electronics impact on the power system design compared to *Chapter 2*. The main findings of the analysis are utilized in the second part of the chapter, where a sizing procedure for a multi-generator power system is

developed. The proposed procedure takes into account the power electronics reliability in the decision-making process. In fact, it defines the optimization space for sizing the multiple generation units and connected power converters. The procedure is intended to be used in combination with the forecasting method presented in *Chapter 3* for the long-term planning of a modern power electronics-based power system.

4.2 Single-Generator Case

In the case of a power system with only one generation unit, it is profoundly easier to examine the impact of power electronics reliability on different aspects. For example, power electronics influence on the selection of the optimum generation size of the system can be analysed. In addition, the impact of different parameters on the power electronics reliability and, consequently, the economic profitability of the power system can be described. For that purpose, a single-generator, multi-converter power system presented in *Chapter 2* is used and shown in Fig. 4.1. To evaluate the aforementioned aspects, the parts of the comprehensive model presented in *Chapter 2* are also utilized. Those include the Power System Performance Model (PSPM), Power Electronics Reliability Model (PERM), and Economic Model (EM), as illustrated in Fig. 4.1. Such selection of models refers to that the power electronics reliability is determined with mission profile-based PoF approach. Detailed specifications of power devices considered within PERM model are provided in [J3]. The input environmental conditions and economic parameters shown in Table 2.1 and Table 2.2 are also utilized for the aforementioned models. Furthermore, EM is updated to determine the profitability of the system. In such a way, it can be described how power electronics can also contribute to the revenue generation in the power system [104,105].

The economic profitability of the system is defined through Net Present Value NPV :

$$NPV = \sum_{t=1}^{T_{PH}} \frac{R_{sys}(t) - C_{sys}(t)}{(1+r)^t} \quad (4.1)$$

where $C_{sys}(t)$ and $R_{sys}(t)$ are yearly cost and revenue contributions, respectively, r is a discount rate that accounts for the time value of money [106].

In the case of cost evaluation, C_{sys} defined in (2.1) is adjusted to comply with the requirements of the study. Thus, it only accounts for C_{cap} , $C_{o\&m}$ and C_{rel}^{PE} . Revenue R_{sys} is defined following the selected energy management strategy and the system application [107]. In this case, revenue can be generated through the system savings due to the internal load supply and the grid feed-in. A detailed explanation of revenue-related parameters, together with

4.2. Single-Generator Case

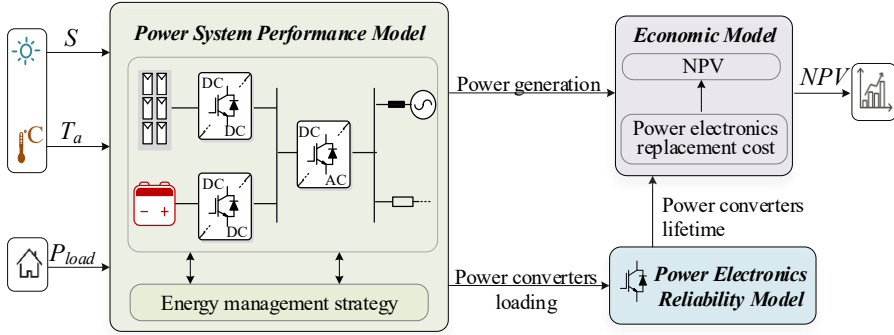

Fig. 4.1: Illustration of the model and the configuration of the system used in the single-generation unit power system sizing studies. Source: [J3].

their mathematical expressions and connections with the rest of the model are provided in [J3].

4.2.1 Impact of Power Electronics Reliability

To evaluate the impact of power electronics reliability on the economic profitability and sizing decisions, the LC development for the expected operating conditions over T_{PH} is examined. The replacement times due to the wear-out failures are shown in Fig. 4.2 for the different combinations of PV arrays (i.e., single generator in the system) and battery energy storage sizes. The battery converter and the inverter are considered to be the reliability-critical components of the power system under study. They both need to be replaced during T_{PH} span for the majority of the PV array P_{gen}^{nom} and battery E_{bat} combinations.

It is necessary to identify the parameters and processes in a single - generation unit power system that have such a deteriorating effect on power electronics reliability. It is equally important to distinguish between the influence that the generation unit size and the specific power system characteristics have on the reliability results. For example, the results in Fig. 4.2(a) show that the battery converter is expected to be replaced at least once during T_{PH} of the single-generator power system under study. This refers to that the replacement will occur regardless of the selected generation and storage size mix. This result is a consequence of the accelerated LC that occurs due to the high dynamics in the battery converter loading profile. The large and frequent changes in the loading are a consequence of the energy distribution in the system that is defined by the selected energy management strategy. Thus, the battery converter lifetime is dependent on the processes characteristic to the power system. A similar is not observed in the case of the inverter unit. There, the results in Fig. 4.2(b) indicate that the inverter lifetime is strongly dependent on the generation unit size P_{gen}^{nom} . In fact, for the larger

Chapter 4. Integration of Power Converters Reliability into Long-Term Power System Sizing

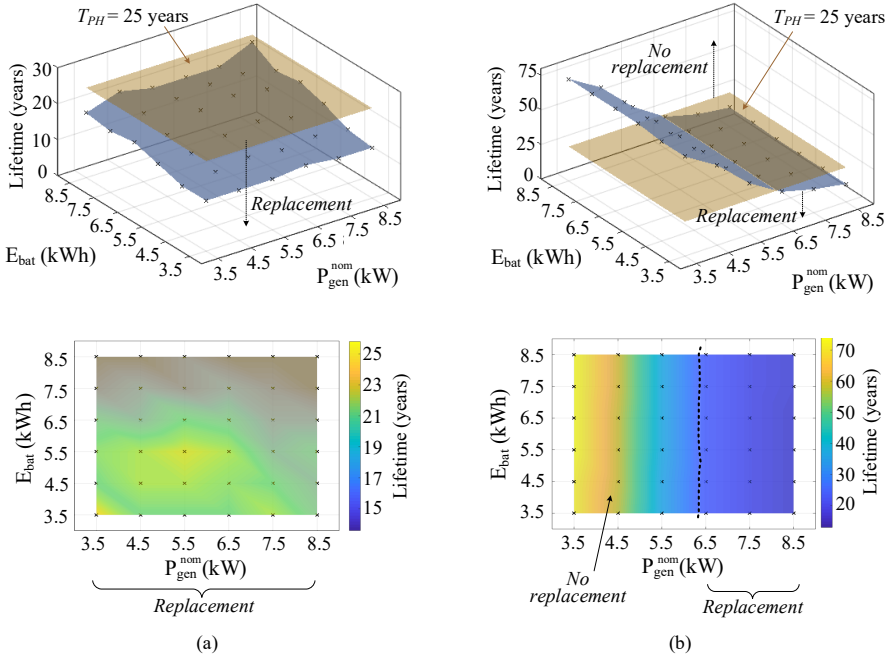

Fig. 4.2: Lifetime of the reliability-critical components for a combination of generation P_{gen}^{nom} and energy storage E_{bat} sizes in a single-generator power system, where the reference planes (marked in brown) represent the planning horizon $T_{PH} = 25$ years: (a) battery converter, and (b) inverter. Source: [J3].

PV array sizes, the inverter lifetime shortens significantly. In such cases, the inverter loading increases with the increase of the PV generation that is used to supply the load and grid feed-in.

The observed lifetime and reliability aspects of the battery converter and inverter units are included in the analysis of the economic profitability of the system. There, the impact of power electronics replacement cost C_{rel}^{PE} can be analysed together with the revenue estimation R_{sys} of the system. The NPV results shown in Fig. 4.3 indicate that the power system profitability reduces with the increase of the generation P_{gen}^{nom} and storage E_{bat} sizes. This applies especially to a large PV array size and a small battery size. In such cases, there is a substantial PV power generation that cannot be stored in the battery with a limiting capacity. As a result, the majority of the power generated by the PV system is fed into the grid, which creates an additional revenue R_{sys} . Nonetheless, the results in Fig. 4.3 indicate that the additional revenue stream R_{sys} is insufficient to cover the related replacement costs C_{rel}^{PE} . Therefore, this analysis showcases that power electronics reliability plays an important role in the optimum power system sizing. In addition, the NPV results are compared with the ones obtained without considering the replace-

4.2. Single-Generator Case

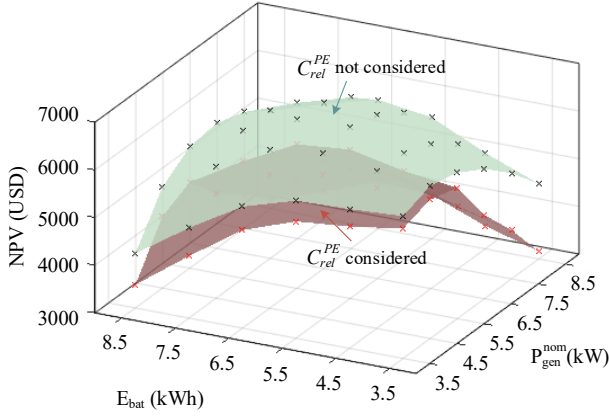

Fig. 4.3: Net Present Value NPV for a combination of generation P_{gen}^{nom} and energy storage E_{bat} sizes in a single-generator power system. Red and black marks denote profitability with and without included power electronics reliability cost C_{rel}^{PE} , respectively. Source: [J3].

ment cost. For the latter, the economic profitability of the system appears higher, which leads to misjudgments in the decision-making process during the power system sizing. Those findings comply with the ones in *Chapter 2* that emphasize the importance of including power electronics reliability in the economic assessment. In addition, they provide the rate of difference in the estimated NPV for the generation and storage sizes affected by the aforementioned characteristics.

4.2.2 Impact of Mission Profile

The mission profile is also considered as one of the parameters that has the potential to highly impact the power electronics reliability [55]. Thus, it is worth to examine its influence on the modern power system design. In the previous analysis, a mission profile from the installation site in Germany was considered. This profile is characterized by a low solar irradiance S year-round. To account for the remainder of the mission profile characteristics, two additional installation sites are accounted for, namely Colorado and Spain. The former is characterized by large variations in T_a , while the latter has a high average S with small inter-seasonal T_a variations. The summary of the main characteristics of the three mission profiles is provided in Fig. 4.4.

The analysis of NPV results reveals that the same combination of the PV array P_{gen}^{nom} and battery size E_{bat} is considered optimum for the two newly added mission profiles. It equals 3.5 kW for the PV array and 8.5 kWh for the battery storage, which differs from the mission profile in Germany. There, a larger PV array that equals 5.5 kW and a smaller battery with 5.5 kWh capacity are optimum. Such sizing results are directly related to the mission

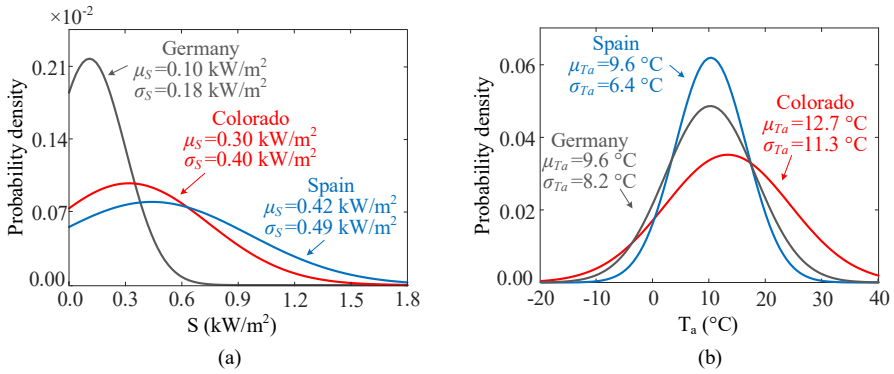

Fig. 4.4: Mission profile characteristics for the installation sites in Germany, Colorado, and Spain: (a) solar irradiance S and, (b) ambient temperature T_a . Source: [J3].

profile characteristics. For a mission profile in Germany, a lower solar irradiance results in a lower energy yield from the PV system. This makes the investment in a larger battery unit unprofitable. In addition, smaller PV arrays are utilized in Colorado and Spain, as they are more profitable and yield sufficient energy to supply the load demand.

To further examine the power electronics impacts on the optimum solution, the lifetime of the reliability-critical components is compared for the three installation sites and two optimum sizes. They are denoted as *Case 1* and *Case 2* together with the corresponding results in Fig. 4.5. In *Case 1*, the largest sensitivity to the mission profile characteristics is observed for the inverter. Its lifetime in Colorado and Spain installation sites is significantly lower than in Germany (optimum solution). Such results are a consequence of a high S and T_a of those mission profiles, which lead to the increased loading of the inverter. This results in an accelerated LC and earlier failure due to wear-out than in the installation site in Germany. Moreover, the lowest inverter lifetime (observed for mission profile in Colorado) confirms that the impact of the intra-day mission profile variations on the power electronics lifetime and reliability should not be neglected. The inverter sensitivity to the mission profile characteristics is also observed in *Case 2*. There, the inverters lifetimes for the installation sites in Germany and Spain are significantly higher than T_{PH} . This refers to the fact that the inverter is under-utilized and its economic viability cannot be achieved. Thus, the two cases demonstrate that the mission profile characteristics need to be taken into account during the power converter design and power system sizing.

The NPV results for the three mission profiles are provided in Table 4.1. Several conclusions on the impact of mission profiles can be drawn from the presented economic results and the above analysis. Firstly, it is more profitable to replace the units often than invest in over-dimensioned units with a

4.2. Single-Generator Case

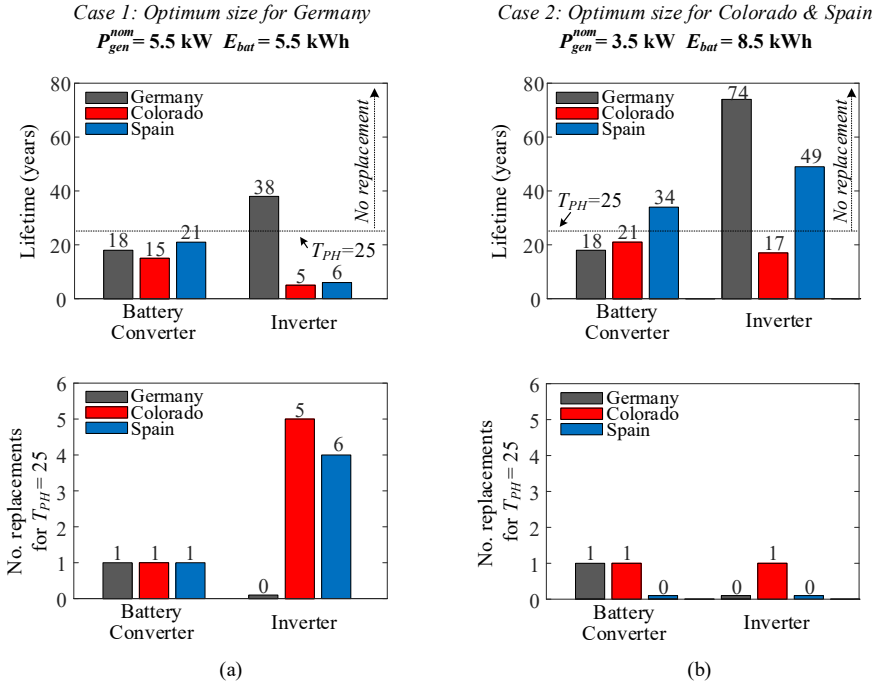

Fig. 4.5: Lifetime and number of replacement of reliability-critical components during the planning horizon T_{PH} of 25 years for: (a) Case 1 with $P_{gen}^{nom}=5.5 \text{ kW}$ $E_{bat}=5.5 \text{ kWh}$ corresponding to the optimum sizes for mission profile in Germany and, (b) Case 2 with $P_{gen}^{nom}=3.5 \text{ kW}$ $E_{bat}=8.5 \text{ kWh}$ corresponding to the optimum sizes for mission profile in Colorado and Spain. Source: [J3].

high cost and under-utilization risk. Moreover, the number of replacements should not be too high to impose the escalated replacement cost C_{rel}^{PE} . In fact, it is important that this component of the overall system cost C_{sys} can be covered by the revenue R_{sys} generated during T_{PH} . Finally, a detailed analysis of the power electronics impact on the optimum size and economic prof-

Table 4.1: Influence of mission profile on lifetime of reliability-critical components and economic profitability (measured in Net Present Value NPV) of a single-generator unit power system. Source: [J3].

	Case 1			Case 2		
	$P_{gen}^{nom} = 5.5 \text{ kW}$ $E_{bat} = 5.5 \text{ kWh}$			$P_{gen}^{nom} = 3.5 \text{ kW}$ $E_{bat} = 8.5 \text{ kWh}$		
Mission Profile	Germany	Colorado	Spain	Germany	Colorado	Spain
NPV (USD)	6125	17250	19860	5055	20700	23755
No. replaced units	2	9	8	1	4	4

itability can be used as the basis for the development of the multi-generation, multi-converter power system sizing methods. This aspect is discussed in the following, where the main power electronics reliability-related results of the conducted analysis are included in the proposed method.

4.3 Multi-Generator Case

When a multi-generator power system is considered, the size of the several different generation units over a long-term horizon needs to be determined. In such cases, multi-generator power systems can range in scale and power rating. For example, they can be as small as the residential PV system used in a single-generator power system sizing studies. More frequently, they can be of a much larger scale, with numerous generation units, where each unit contributes to only a fraction of the total load demand. To study such complex systems, a multi-variable optimization problem needs to be defined. The optimization solution should provide the optimum size and the number of generation units over the long-term planning horizon T_{PH} . In such a case, it becomes ineffective to examine the influence of power electronics in the same way as in the case of a single-generator power system. Therefore, it is necessary to define an optimization procedure which includes power electronics reliability aspects in the sizing decisions.

4.3.1 Optimization Space

Several requirements need to be considered when developing the optimization procedure. First, the goal is set to find the optimum size, deployment and replacement time of both the generation unit and its power converters (i.e. optimization variable). Furthermore, a sufficient generation capacity to cover the increasing load demand P_{load} over a long-term planning horizon T_{PH} needs to be assured. The optimum results need to be reflected in the minimized overall cost of the planned system C_{sys} , which also includes the power electronics reliability cost C_{rel}^{PE} . As in the case of a single-generator power system, the procedure for a multi-generator power system is developed on the example of PV arrays as the generation unit and PV inverter as its power electronic unit. Hence, the power system is designed as an optimal combination of multiple PV units over the long-term horizon. The optimization space is constructed in the form of stages and states, which resemble Dynamic programming optimization principles [108]. As illustrated in Fig. 4.6, the planning horizon T_{PH} is divided into a series of discrete-time instances (years) represented by stages. For each stage, there are several feasible outcomes of the optimization variable, which are modelled as states. Thus, a certain combination of PV arrays nominal power P_{gen}^{nom} and PV invert-

4.3. Multi-Generator Case

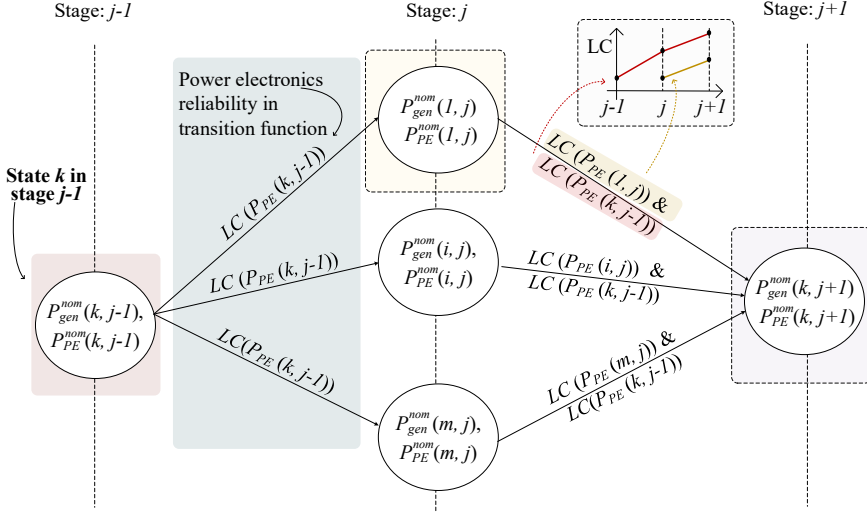

Fig. 4.6: Optimization space for a multi-generator power system planning with included power electronics reliability in the decision-making process. The planning horizon is divided into stages, while the states represent different combinations of the PV arrays P_{gen}^{nom} and the PV inverters P_{PE}^{nom} sizes. Power electronics reliability is included in the transition function between the states of the consecutive stages through inverter lifetime consumption LC . Source: [C4].

ers nominal power P_{PE}^{nom} defines a single state. Three fundamental options for the state definition are specified and illustrated in Fig. 4.7. *Option 1* covers the case where a new PV array and a new inverter are installed in stage j of the planning horizon T_{PH} . In *Option 2*, it is assumed that the additional PV arrays are added to the PV unit installed before stage j . The two options allow for the definition of several states with different combinations of the nominal powers of the two units. As a part of the third option, a condition that no new units are installed at stage j is covered. Thus, this option is represented with a single state, where P_{gen}^{nom} and P_{PE}^{nom} parameters equal zero. The transition from any state in stage j to any of the states in the following stage $j+1$ is defined by the transition function, which is also marked in blue in Fig. 4.6. The overall cost of the system to be minimized $C_{sys}(i, j)$ is defined based on the two aforementioned aspects, i.e., $C_{state}(i, j)$ cost of being in state i and $C_{trans}(i, j)$ cost of transition from state i :

$$C_{sys}(i, j) = C_{state}(i, j) + C_{trans}(i, j) + C_{sys}^{opt}(j-1) \quad (4.2)$$

where $C_{sys}^{opt}(j-1)$ is the optimum system cost determined up to the stage j (i.e. optimum path). Representation of C_{sys} variable does not differ from the cost used in the case of a single generator power system or the one specified in Chapter 2 and Table 2.2. However, in this case, it is defined to adhere to the optimization space requirements. With respect to that, the capital cost is

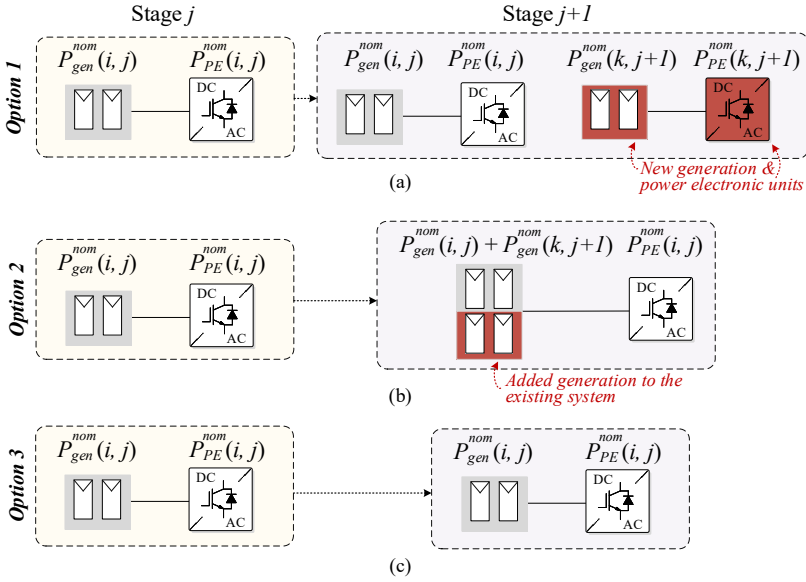

Fig. 4.7: State definition in the optimization space based on three options: (a) Option 1: a new PV array and inverter are added in stage $j + 1$, (b) Option 2: additional PV arrays are added to the already existing PV installed in the stage j , and (c) Option 3: neither new PV arrays are added to the existing units nor new PV array and PV inverter are installed. Source: [C4].

included in the state cost C_{state} . It represents the capital cost of the PV array C_{cap}^{gen} and PV inverter C_{cap}^{PE} , which reflects one of the three options in Fig. 4.7. Transition cost $C_{trans}(i, j)$ defined in (4.3) accounts for the operation & maintenance (O&M) cost $C_{om}(i, j)$ and the cost of power electronics reliability $C_{rel}^{PE}(i, j)$ for stage j . Moreover, it also accounts for the accumulation of the two costs for the optimum path of T_{PH} covered up to stage j . It is represented with the transition stack cost $C_{TS}(i, j)$ defined in (4.4).

$$C_{trans}(i, j) = C_{om}(i, j) + C_{rel}^{PE}(i, j) + C_{TS}(i, j) \quad (4.3)$$

$$C_{TS}(i, j) = \sum_{n=1}^j \sum_{t=T_i(n)}^j C_{rel}^{PE}(n, t) + C_{om}(n, t) \quad (4.4)$$

In (4.4), T_i represents the PV inverter installation time, t is the time since installation time, and n represents the installed unit in the optimum path.

The transition stack is highlighted as the most significant contribution of the defined method, as it accurately accounts for the reliability of each power converter in the power system [C4]. In fact, it stores information about LC accumulation between each stage of the planning horizon T_{PH} for every PV converter in the optimum path. This principle is illustrated in Fig. 4.6 for

4.3. Multi-Generator Case

the transition function to the stage $j + 1$. It is important to emphasize that the transition stack also accounts for changes in a PV inverter loading for the stages where *Option 2* (illustrated in Fig. 4.7) is selected. In such a way, the replacement cost of each power converter can be accurately determined and included in the optimization procedure. It is worth mentioning that the transition stack does not represent a tangible cost of the system. Rather, it is defined in the optimization space to account for the power electronics reliability in the decision-making process.

4.3.2 Impact of Power Electronics Reliability

The impact of power electronics reliability on the sizing decision is shown in Fig. 4.8. The results indicate that there is no distinction in the optimum size of the installed PV inverters P_{PE}^{nom} when power electronics reliability is not included (baseline) and when it is included in the sizing decisions. However, a crucial difference lies in their optimum installation times. An equally relevant difference is seen for the PV array sizes P_{gen}^{nom} and installation times. It is observed that the optimum allocation of PV arrays has a significant influence on the PV inverter reliability and lifetime. In fact, when power electronics reliability is not considered in the optimization, adding PV arrays to the existing PV system (*Option 2* in Fig. 4.7) seems like a favorable choice. From

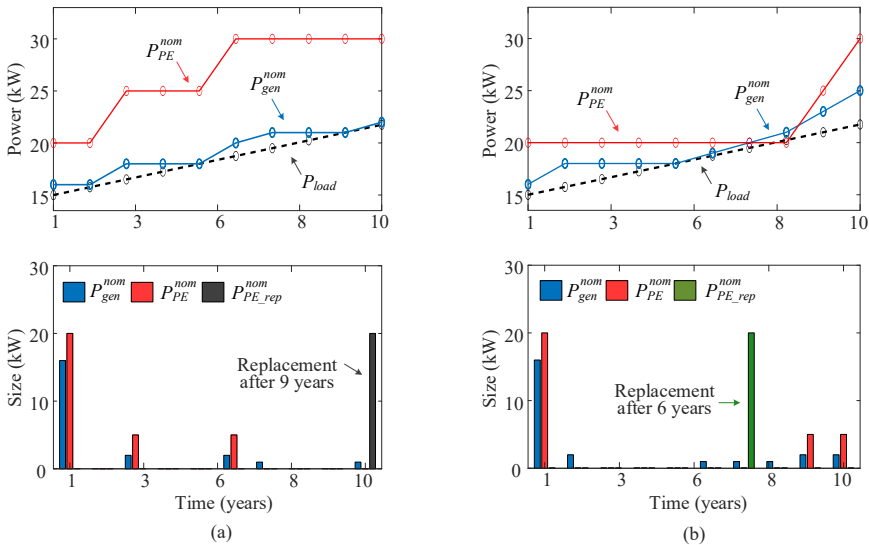

Fig. 4.8: Optimum PV arrays P_{gen}^{nom} and PV inverters P_{PE}^{nom} sizes and installation times for a planning horizon $T_{PH} = 10$ years to meet growing load demand P_{load} : (a) with including power electronics reliability in the decision-making process, and (b) without including power electronics reliability in the decision-making process. Source: [C4].

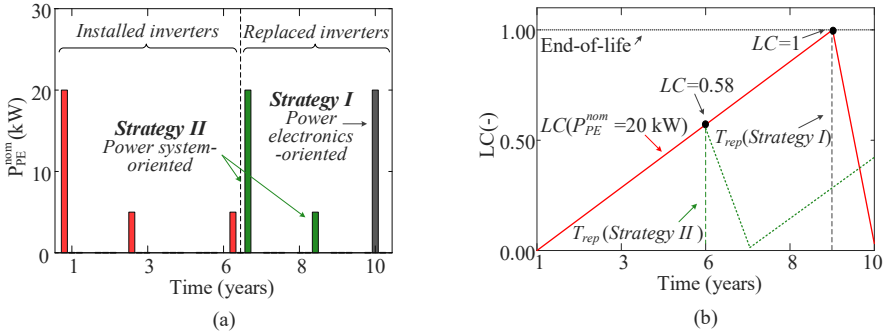

Fig. 4.9: Impact of maintenance strategies in a multi-generator power system on: (a) Replacement times, and (b) Utilization rate of PV inverter shown in amount of lifetime consumed LC before the replacement takes place. Source: [C4].

an economic perspective, it is superior to investing in a new PV inverter to add the needed generation capacity. Nonetheless, such situations lead to the accelerated LC of the PV inverter due to the increase in its electrical loading. As a result, the PV inverter wear-out failure occurs, which leads to the PV inverter replacement that takes place 3 years earlier in baseline. Such situations are avoided when the power system is sized by including the power electronics reliability, as shown in Fig. 4.8(b). The findings of this analysis correspond to the ones discussed in detail for a single-generator power system. Thus, the relevant power electronics reliability effects are properly included in the planing of the multi-generator power system.

Aside from its impact on the power system sizing, the influence of power electronics reliability can be examined for other planning aspects, such as maintenance strategies. To do so, the optimum sizing results of the system with included power electronics reliability are used as a basis to which two different replacement strategies are added. (*Strategy I*) is a power electronics reliability-driven replacement strategy. There, the PV inverter replacement takes place at the end of its lifetime, i.e., for LC value equal to unity. On the contrary, *Strategy II* is a power system reliability-oriented strategy. There, a PV inverter replacement occurs at the fixed-term intervals, regardless of the actual PV inverter state-of-health (i.e., LC value). The results in Fig. 4.9(a) refer to more frequent replacements of the units for *Strategy II*. Moreover, LC results of the PV inverter installed at $T_{PH} = 1$ year shown in Fig. 4.9(b) indicate that this unit is not fully utilized. In fact, less than 60% of its lifetime is consumed when the replacement occurs. However, in this case, a detailed analysis of the synergy between the power electronics lifetime, power system reliability requirements and cost assessment needs to be administered. Nonetheless, the obtained results indicate that the existing replacement processes can be updated with newly obtained power electronics reliability re-

4.4. Summary

sults to aid the optimum replacement strategy of a modern power system, in this case, exemplified with a PV system.

Finally, the proposed procedure can be used for the design of a larger-scale power electronics-based power system. For example, it can be utilized to find the optimum size and deployment time of the different generation units and technology types. It can also be used to include the rest of the units that require a power electronics interface (e.g., storage units) in the power system design. In such a case, a design of a larger-scale power system can be conducted, while taking into account the power electronics reliability of a diverse combination of power system components. In addition, the proposed sizing procedure presented in this chapter can be combined with the long-term forecasting method proposed in *Chapter 3* to minimize uncertainty in a cost-effective and reliable power electronics-based power system planning.

4.4 Summary

In this chapter, approaches to the integration of power electronics reliability into long-term power system sizing are presented. First, the analysis of the power electronics reliability impact on the long-term sizing of the power system with a single generator power system is conducted. It provides an important insight into the various ways the power electronics reliability impacts the optimum size of the power system being planned. It is shown that the power electronics replacement cost can outweigh the revenue generation of the power system. In addition, the optimum generation size is heavily influenced by the mission profile characteristic, which also affects the expected lifetime of the power converters. In the second part of the chapter, an optimization method for the long-term generation capacity planning of the modern power system is presented. The method includes power electronics reliability in the decision-making process. It can be used for the power system with multiple generation sources interfaced by power electronics. The method can be used to avoid the sizing of the generation units over the long-term horizon that leads to accelerated power converter lifetime consumption and early replacements. Furthermore, it is demonstrated on the example of the maintenance strategies how power electronics reliability can be used to further update the planning processes.

Related Publications

- J3. **M. Sandelic**, A. Sangwongwanich, and F. Blaabjerg, "Impact of Power Converters and Battery Lifetime on Economic Profitability of Residential Photovoltaic Systems," *IEEE Open J. Ind. Appl.*, vol. 3, pp. 224-236,

August 2022.

Main contribution:

This paper provides a comprehensive examination of the power electronics reliability impact on the optimum sizing results of a power system with a single generator. It also includes the analysis of the influence of various external parameters on the power electronics reliability and consequently the profitability of the planned system.

- C4. **M. Sandelic**, A. Sangwongwanich, S. Peyghami and F. Blaabjerg, "Multi-Year PV Generation Planning Incorporating Power Electronics Impacts in Sizing Decisions," in *2023 IEEE Power and Energy Society General Meeting (PESGM)*, Orlando, FL, USA, 2023, pp. 1-5.

Main contribution:

This paper presents the optimization method for long-term planning of the modern power system with multiple power electronics-interfaced generation sources. It includes the power electronics reliability in the decision-making process. The method can be used to determine the optimum size of the generation units and power electronics over a long-term planning horizon.

Chapter 5

Investigation of Power Electronics-Aided Generation Impacts on Power System Reliability

5.1 Background

Previous chapters dealt with the adverse effect of the increasing installation rate of power electronics in the power system. Conversely, this chapter intends to investigate power electronics characteristics that can be favorable for the power system. One such characteristic is observed when the first generation of power converters installed in the power system (i.e., legacy inverters) are replaced with smart inverters [109]. Those units have more advanced control capabilities compared to the legacy inverters. In fact, they can actively participate in assuring power system reliability during operation [110], as also illustrated in Fig. 5.1. Moreover, they can stay connected to the power system during contingency events [111]. To utilize such benefits, it is pivotal to completely understand to which extent the smart inverters can help the power system. Such observations can be a valuable asset in the planning of future modern power systems, as shown in Fig. 5.2. There, design actions can be undertaken to aid the reliability of the power system during operation utilizing the grid-supporting power electronics. Therefore, in this chapter, a method for a systematic evaluation of smart inverter benefits during contingency events related to load shedding in the power system is developed based on [J4]. The main aim is to define realistic operational

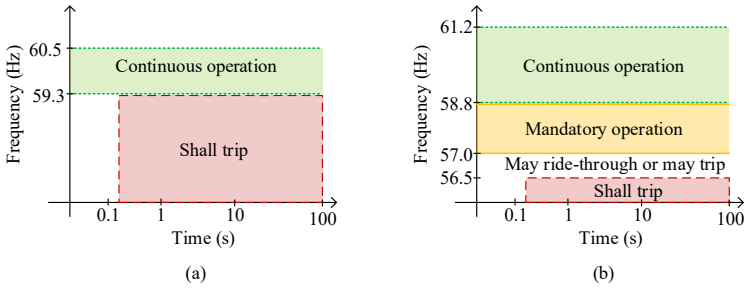

Fig. 5.1: Power electronics operating area for various power system frequency levels according to IEEE Std 1547 [111] for: (a) legacy inverters, and (b) smart inverters. Source: [J4].

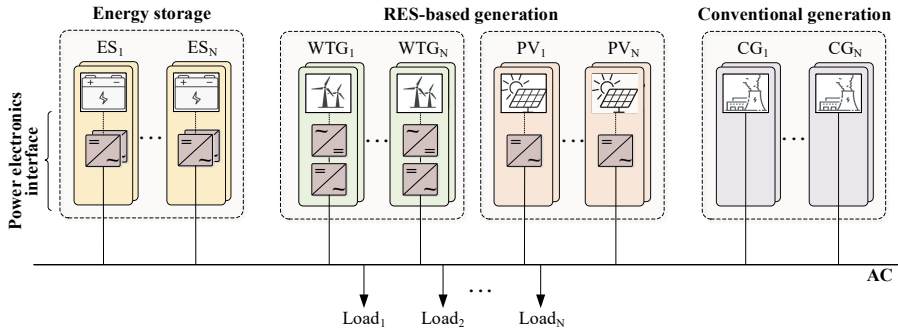

Fig. 5.2: Illustration of the power electronics-based power system with the generation and storage units interfaced by the power converters. Power electronics interface can consist of legacy inverters or smart inverters, where the latter have grid support capabilities. Source: [J4].

scenarios which can be used to assess the relative power system reliability improvements that are achieved by smart inverters.

5.2 Generating Scenarios of Power System Contingencies

The framework for the investigation of the power electronics grid support functionalities is shown in Fig. 5.3. It is developed to account for all realistic scenarios which have the potential to lead to load shedding in the power system. Those scenarios can be used to investigate the reliability of the power system with power electronics that either can or cannot provide grid support services. To account for all realistic scenarios, steps 1 & 2 of the proposed framework shown in Fig. 5.1 are defined. As part of *Step 1*, the scenarios which lead to contingencies due to generation unit outages as well as their probability are defined. In the next step (*Step 2*), the mathematically defined scenarios are combined with the scheduling results of the power sys-

5.2. Generating Scenarios of Power System Contingencies

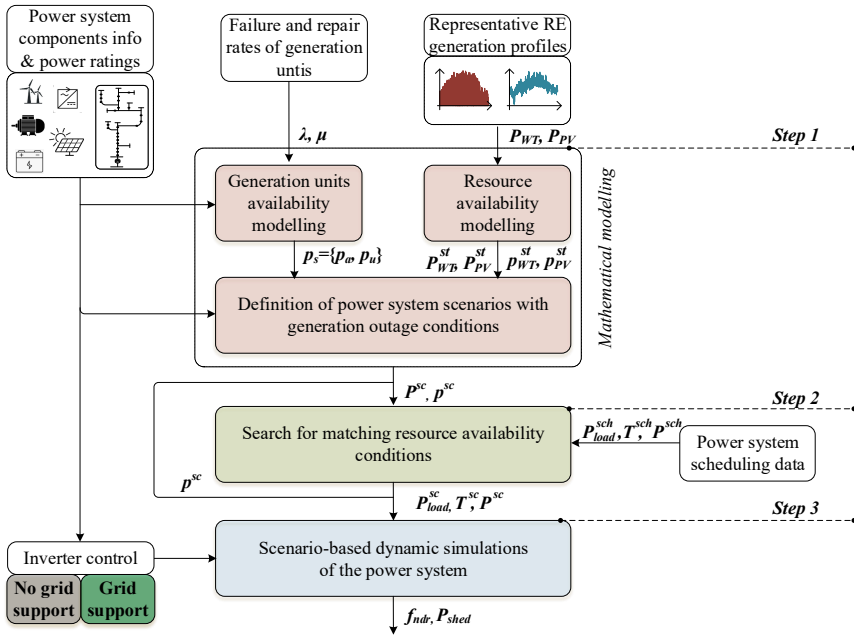

Fig. 5.3: Framework for assessment of power electronics grid support capabilities for power system reliability improvements during operation. Source: [J4].

tem. Thus, in this step, more detailed and realistic power system conditions during operation are provided. Finally, dynamic simulations of the power system with smart inverters are conducted for the generated scenarios of the first two steps. The main modelling aspects of the three parts are described as follows, while detailed descriptions are provided in [J4].

5.2.1 Mathematical Approach

Scenarios are defined to account for a single-generator outage in the power system. This entails modelling the generation unit availability to determine its state probability vector p_s . It contains the probability that a generation unit is available p_a (marked in Fig. 5.4 with UP state) or unavailable p_u (marked in Fig. 5.4 with DOWN state). When the unit is available (UP), its normal operation is assumed. On the contrary, when the unit is unavailable (DOWN), it is in an outage state, which leads to the power system contingency. A transition from the UP state to a DOWN state is defined with a failure rate λ , while the opposite transition is indicated with a repair rate μ . Those parameters are

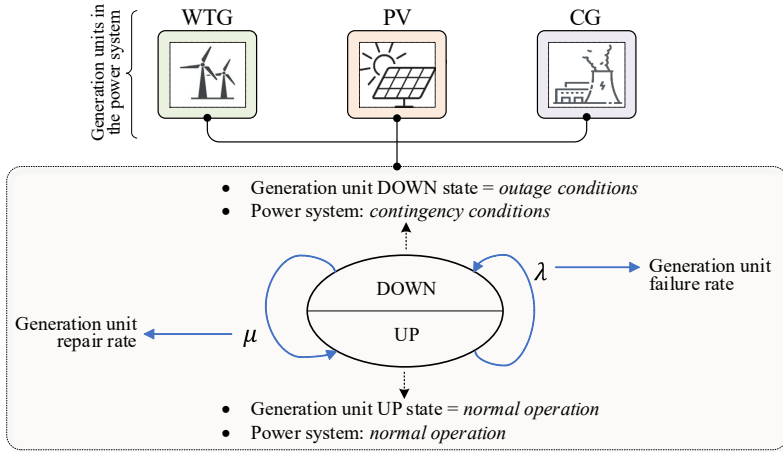

Fig. 5.4: Illustration of generation unit availability modelling. Source: [J4].

utilized to evaluate p_u and p_a probabilities as follows [83]:

$$p_u = \frac{\lambda}{\mu + \lambda} \quad (5.1)$$

$$p_a = \frac{\mu}{\mu + \lambda} \quad (5.2)$$

In a parallel process, resource availability modelling takes place, as indicated in Fig. 5.3. This is an important aspect of a modern power system with a large installation rate of the resource-dependent renewable energy sources (RES)-based generation, such as PV and wind turbine generator (WTG). Resource availability modelling aims to provide the occurrence probability p^{st} of a certain resource availability level P^{st} for those units. To determine P^{st} and p^{st} , a historical mission profile is used, as indicated in Fig. 5.3. Data points contained in the historical mission profiles are grouped based on their similarity. The grouping process resembles the clustering procedure (Initial elements division outlined in Fig. 3.3) presented in Chapter 3. The mean value of each group of data points is a representative power level P^{st} . Furthermore, the probability of each level p^{st} is evaluated by examining the number of data points of the historical mission profile that belongs to it.

Generation units and resource availability parameters are employed in the last part of the mathematical modelling (*Step 1*), where contingency scenarios are defined. Those scenarios account for a single unit outage of each power generator in the power system, where different resource availability levels are included. Thus, to cover the outage of the i -th generation unit and L different resource availability levels, L scenarios need to be defined. Concerning that, a probability of k -th scenario $p^{sc}(k)$ with i -th generation unit unavailable and

5.2. Generating Scenarios of Power System Contingencies

l -th resource availability level is defined as follows:

$$p^{sc}(k) = p_u(i) \times \prod_{j=1}^{N_{CG}} p_a(j) \times \prod_{j=1}^{N_{WTG}} p_a(j) \cdot p_{WTG}^{st}(l) \times \prod_{j=1}^{N_{PV}} p_a(j) \cdot p_{PV}^{st}(l) \quad (5.3)$$

where N_{CG} , N_{WTG} and N_{PV} are the number of available CG, WTG, and PV units, respectively.

For k -th scenario defined by the probability $p^{sc}(k)$, a maximum power output of each generation unit is defined in vector $P^{sc}(k)$. For the units which are not in the outage stage (i.e., UP/available), the maximum power output of conventional generators (CG) equals the nominal power, while for PVs and WTGs, it equals $P^{st}(l)$ defined within the scenario. Thus, the result of the mathematical modelling is a table with scenarios defined by P^{sc} and p^{sc} vectors.

5.2.2 Connection with Scheduling Data

In the previous step, mathematical modelling covered all the scenarios that lead to the power system contingency due to a single generator outage. To investigate the smart inverter benefits during load shedding, it is important to provide realistic operating conditions. For that purpose, one-year hourly scheduling data for the power system under study are utilized. They can provide information about load levels for each scenario based on the matching power availability of RES-based generators (e.g., PVs and WTGs). Moreover, the scheduling set point for CG can be obtained, which will provide a realistic operational span of those units when the contingency occurs. In addition, the temporal characteristics can be obtained for each scenario.

The procedure for combining the results of the mathematical modelling and scheduling data is shown in Fig. 5.5. First, each hourly scheduling data of PVs and WTGs is converted into corresponding availability levels P^{st} . This includes comparing the PVs and WTGs power outputs P_{PV}^{sch} , P_{WT}^{sch} contained in the scheduling data with each of the availability levels P_{PV}^{st} , P_{WT}^{st} . In the following process, each hourly data is attributed to a scenario matching the resource availability. This is followed by choosing the representative hourly scheduling data based on the minimum Euclidean distance between PVs and WTGs outputs P_{PV}^{sch} , P_{WT}^{sch} and P^{sc} of all hourly scheduling data attributed to the scenario. By doing so, it will be ensured that the resource availability level is matched as closely as possible to the realistic power system conditions. In addition, this will ensure that the expected grid support benefits of the smart inverters can be realistically assessed. As indicated in Fig. 5.5, in the last part of the procedure, the load level P_{load}^{sch} and temporal characteristics T^{sch} of the chosen hourly data are attributed to the scenario. Moreover, CGS scheduling data P_{CG}^{sch} are updated in P^{sc} vector.

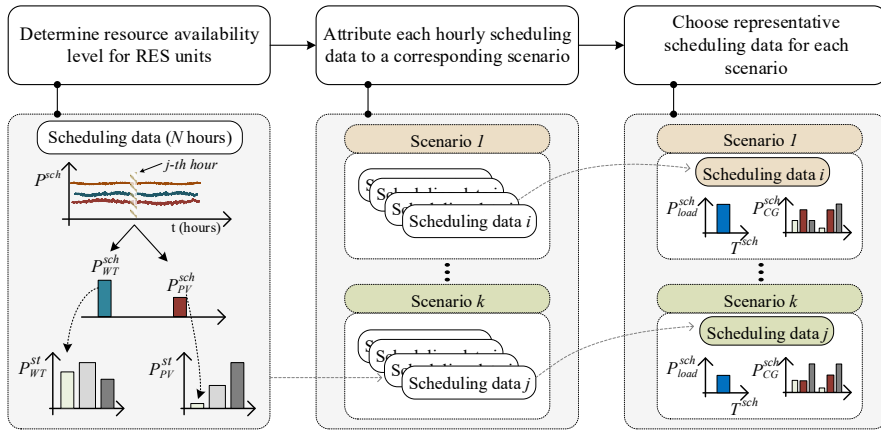

Fig. 5.5: Illustration of the search for matching resource availability levels in the power system scheduling data, which corresponds to Step 2 in the proposed framework. Source: [J4].

5.2.3 Dynamic Simulations of Power Electronics-Based Power System

The last step of the proposed procedure (*Step 3*) includes the scenario-based dynamic simulations of the power system, as indicated in Fig. 5.3. In this step, the scenarios defined within the mathematical modelling, and updated in the following step with the scheduling data, are simulated for the power system under study. Dynamic simulations are conducted for one hour, where the scheduling of the units is done according to values in P^{sc} and P_{load}^{sc} . Dynamic simulations are then performed, where a reliable power system operation is assured in the first 15 minutes. This is evaluated by examining if the power system frequency is within the allowable limits for normal operation. Afterwards, the outage of the unit is set to occur. In the following minutes, the power system frequency response is evaluated. If the load-shedding conditions are met, the load will be shed P_{shed} according to the grid codes.

To conduct such dynamic simulations, a Multi-timescale Integrated Dynamics and Scheduling (MIDAS) tool is used [112]. It enables detailed power system simulations starting with the economic scheduling to dynamic stability response analysis. Moreover, the MIDAS tool is developed to account for power system characteristics with a high installation rate of power electronics. Thus, to investigate the smart inverter benefits, dynamic simulations in MIDAS are conducted with two different inverter control settings, as indicated in Fig. 5.1 and Fig. 5.3. In the first set of simulations, no grid support is provided by the inverters. This refers to that the power system has legacy inverters as the interface of the RES-based generators. In the second set of simulations, the inverter has grid support functionalities. Thus, all the RES-

based generators (i.e., PVs and WTGs) are interfaced by the smart inverters. In each set of simulations, frequency nadir f_{ndr} and amount of load shed P_{shed} is evaluated. As the result of the analysis, the relative improvement in the power system reliability (measured through f_{ndr}) due to smart inverters can be provided. Moreover, the conditions that lead to load shedding during the realistic operation of the power system can be characterized.

5.3 Assessment of Power Electronics Grid Support Benefits During Contingencies

A selected power system under study is a multi-generator power system with a high installation rate of power electronics-interfaced units. The majority of the generation is provided by the PV units (47.80%), while 15.36% and 36.84% come from the WTGs and CG units, respectively. The failure rate λ and repair rate μ used in the generation units availability modelling are obtained from [113]. The number of representative power levels determined within resource availability modelling is set to 3. The results of the assessment indicate that 8% of all defined scenarios (corresponding to 9 scenarios) result in the load shedding conditions in the power system. A detailed examination of those scenarios reveals that the outage of the different types of generation units results in load shedding in the system.

As indicated in Fig. 5.6 (a), those 9 scenarios include the outage of the two largest CG units (CG₁ for Scenario 1-3 and CG₂ Scenario 4-6) as well as the largest PV unit (PV₁ for Scenario 7-9). The power system conditions, such as load level and the amount of load covered by RES, are also shown in Fig. 5.6 (a) for each scenario and summarized in Table 5.1. Furthermore, the resulting power system reliability (i.e., frequency nadir f_{ndr}), as well as the amount of the load shed P_{shed} , are provided in Fig. 5.6 (b),(c). The results indicate the largest difference in f_{ndr} for Scenarios 3 & 5. In both, P_{shed} is significantly lower for the power system with the smart inverter-interfaced RES-based generation.

A more detailed analysis of the power system conditions reveals that those two scenarios have several similarities. For example, in both, a high percentage of load demand P_{load}^{sc} is covered by RES-based generation with medium to high availability of resources. To that extent, it is worth examining the extent to which the availability of the resources impacts the grid support capabilities of the smart inverters. To do so, the scenarios with no difference in f_{ndr} and P_{shed} for the two types of power electronics units are investigated further. Fig. 5.7 (a) indicates that all those scenarios (i.e., Scenarios 1-2, 4 & 6) have a low resource availability for PV generation. A closer examination of the temporal characteristics T^{sc} shown in Fig. 5.7 (b) reveals that low resource availability

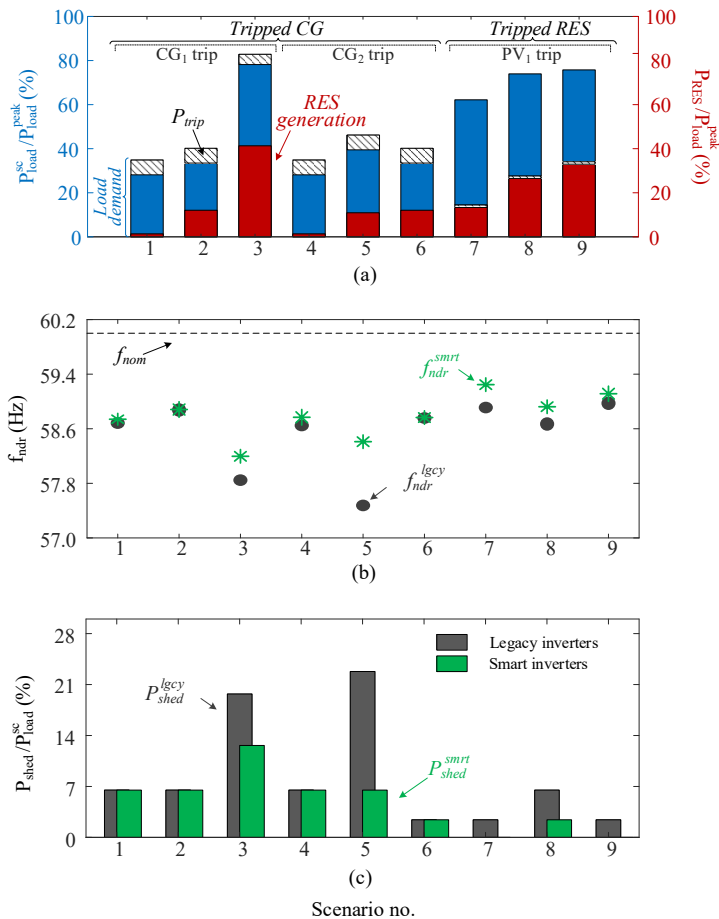

Fig. 5.6: Scenarios which lead to load shedding conditions in the power system: (a) Load (marked in blue), renewable energy-based generation (marked in red), and outage generation (marked with the shaded area) shown as a percentage of power system peak load, (b) frequency nadir f_{ndr} with legacy and smart inverters, (c) Load shedding amount P_{shed} with legacy and smart inverters. Source: [J4].

is in the majority of the scenarios attributed to hours during the day without sunlight. Those conditions impose restrictions on PV power generation and the smart inverter grid support capabilities. Thus, the majority of the smart inverter-interfaced RES-generation cannot be utilized during the contingency situation. In such cases, the actions in the power system undertaken to restore frequency are done majorly by the CG. Contrary to the PV units, a less significant influence of the resource availability for the WTG production on the power system reliability is observed. The reasoning for this can be found in the fact that only 15.36% of the total generation comes from WTG sources.

5.3. Assessment of Power Electronics Grid Support Benefits During Contingencies

Table 5.1: Summary of the load and generation levels as well as the resulting load shedding amounts for the power system with legacy and smart inverters. Source: [J4].

Scenario no.	$P_{load}^{sc}/P_{load}^{peak}$ (%)	P_{RES}/P_{load}^{peak} (%)	P_{trip}/P_{load} (%)	$P_{shed}^{lgy}/P_{load}^{sc}$ (%)	$P_{shed}^{smrt}/P_{load}^{sc}$ (%)
1	34.82	3.88	19.25	6.50	6.50
2	40.14	30.05	16.70	6.50	6.50
3	82.80	49.89	5.61	19.70	12.63
4	34.82	3.88	19.25	6.50	6.50
5	46.15	23.67	14.53	22.79	6.50
6	40.14	30.05	16.70	2.42	2.42
7	62.17	23.24	1.80	2.42	0.00
8	73.96	37.23	1.56	6.50	2.42
9	75.75	44.77	1.53	2.42	0.00

The above observations lead to the conclusion that the resource availability of the dominant RES-based generation in the power system highly impacts load-shedding conditions and the extent of the grid support benefits provided by the smart inverters. Therefore, these aspects should be considered when planning a modern power system to utilize the full extent of the smart inverter advantages over the legacy inverters.

Equally important to examine when quantifying the relative benefits of the smart inverters is the probability of the load shedding occurrence. For that purpose, the results of the mathematical modelling which indicate the probability of each scenario p^{sc} are shown in Fig. 5.8. They suggest that the

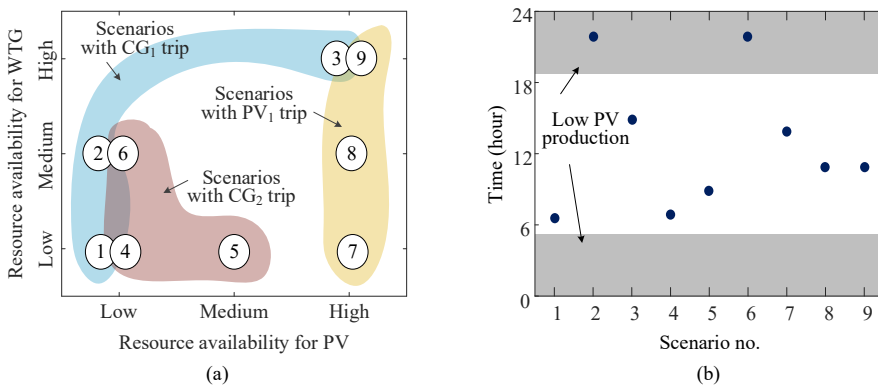

Fig. 5.7: Scenarios which lead to load shedding conditions in the power system: (a) Resource availability levels for CG₁ failures (marked in blue), CG₂ outages (marked in red) and PV₁ outages (marked in yellow), (b) Temporal characteristics in terms of time during the day that the scheduling data corresponding to the scenarios belongs to. Source: [J4].

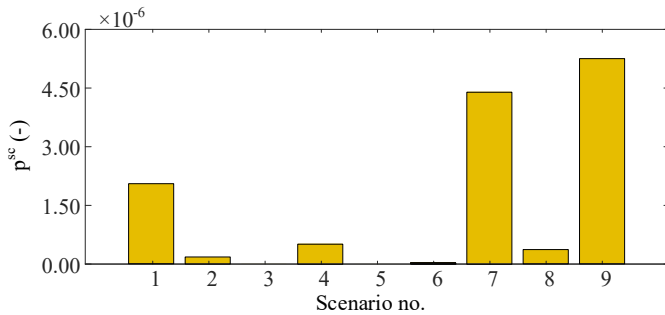

Fig. 5.8: Probability of occurrence of the scenarios leading to the load shedding conditions in the power system. Source: [J4].

events leading to the largest P_{shed} have the lowest probability. Nonetheless, those events have an immense impact on the power system reliability and can cause considerable economic repercussions. Thus, it is important to rely on the grid support capabilities of the smart inverters, which are especially useful in such situations. Furthermore, when the high probability scenarios are examined (e.g., Scenario 7& 9), the advantages of smart inverters over legacy inverters are also observed. For such operating conditions, the relative difference in P_{shed} is smaller compared to the legacy inverter, but a power system with smart inverters has a higher level of reliability (measured in f_{ndr}). Thus, in both cases, the investment in smart inverters on the account of power system reliability seems like a promising option. In addition, those observations, combined with the results above, can be used for the planning of future modern power systems on large scales, where the power electronics-aided reliability improvements can be achieved.

5.4 Summary

This chapter deals with the power electronics features that can be used to benefit the power system reliability. One such feature is observed in grid support functionalities using smart inverters. Thus, the investigation of the smart inverter support during grid contingencies that include load-shedding conditions is conducted. Furthermore, a procedure that enables the investigation of reliability improvements during operation is proposed. The main features of the procedure include combining pure mathematical modelling, scheduling data and dynamic simulations to quantify the power electronics-based benefits during realistic power system contingency scenarios. The results of the analysis suggest significant improvements in the power system reliability for worst-case scenarios. Thus, smart inverters are seen as a favorable option which benefits should be included in the modern power system

planning in the future.

Related Publications

- J4. **M. Sandelic**, X. Liu, J. Tan, and F. Blaabjerg, "Modern Power System Planning for Enhanced Security: Assessment of Smart Inverters Grid Support Benefits," Status: In Preparation

Main contribution:

This paper presents the method for examining the grid support capabilities of smart inverters during load-shedding conditions in the power system. It provides guidelines on how to define the realistic power system scenarios that can be used to quantify the relative improvement in the power system reliability during operation. The proposed method can be used for modern power electronics-based power system planning, where smart inverter-related benefits can be utilized.

Chapter 6

Conclusion

This chapter provides a summary of the main results and the outcomes of the Ph.D. project *Reliability-Oriented Design of Power Electronics-Based Power Systems*. The main contributions as well as the future research prospects are discussed in this chapter as well.

6.1 Summary

The main research focus of this Ph.D. thesis is developing new guidelines for facilitating the design of reliable and cost-effective modern power systems with a high installation rate of power electronics. To that end, several features and challenges related to the accelerated integration of the power electronics into the power system are indicated. The solutions to address such challenges and benefit features are being investigated and summarized as follows.

In *Chapter 1*, the impact of power electronics on power systems has been discussed. It is shown that power electronics play an important role in the modern power system. Furthermore, it is concluded that it is necessary to account for their impact by redefining the current planning guidelines. Moreover, two important aspects of power electronics have been pointed out. Those are long-term impacts in terms of power electronics reliability as well as lifetime and operational impact in terms of power electronics control capabilities to provide grid support. Therefore, those two aspects are further investigated, and the methods for their inclusion in the planning guidelines are considered in the remaining chapters.

In *Chapter 2*, a model is developed to enable the investigation of performance, reliability, and cost aspects of the power system with a high penetration rate of power electronics. The reliability aspect is divided into power electronics and power system analysis. Both models are based on the state-of-the-art assessment in their respective domains. A connection between the reliability

models and the cost is established. The developed model is used to analyse the long-term evolution of system cost based on two reliability aspects and system operation impact. The obtained results suggest that the power system reliability affects the system cost gradually every year. Contrary to this, power electronics reliability effects are less frequent, but with a larger impact. The analysis results indicate that both aspects contribute to the total cost of the system planning. Hence, they need to be included in the planning of the system adequately. By using the proposed model, which establishes the direct relationship between performance, reliability and cost, a more accurate and comprehensive assessment can be conducted during the system planning.

Parts of the model developed in *Chapter 2* are used in *Chapter 3* and *Chapter 4* to integrate the long-term impact of power electronics reliability on power system planning. To that extent, the main challenges related to the long-term forecasting method in power system planning are investigated in *Chapter 3*. A method is developed which enables the power electronics reliability prediction within the forecast process. The method accounts for the uncertainties of the long-term prediction horizon and constructs the profiles of the environmental conditions to aid accurate power electronics lifetime prediction. The performance of the proposed method is compared with the state-of-the-art approaches to power electronics lifetime prediction. The results indicate that the accuracy of the proposed method is higher, especially with the extension of the prediction horizon. Such results demonstrate the benefits of the proposed modelling method, especially as the power electronics-based power systems will require extended operational span in the future. In such cases, the accurate prediction of the power electronics components can help with, among others, a more accurate cost assessment and less unforeseen maintenance activities.

The main outcomes of the investigation undertaken in *Chapter 3* can be applied in the second stage of the long-term planning, i.e., long-term generation sizing of the power system. This aspect is investigated in *Chapter 4*, where the emphasis is put on developing the sizing methodology which determines the optimal size of the generation units as well as power electronic units over a long-term horizon. First, the models employed in *Chapter 2* are used to evaluate the impact of different operating and environmental conditions on power electronics lifetime and the optimal system size for a single generator. Afterwards, an optimization method for optimal sizing of a multi-generator power system is defined. The method accounts for the accumulation of damage for each year of operation that is planned. In such a way, it includes the reliability of power electronics in the decision-making process.

In *Chapter 5*, the operational benefits of power electronics on the power system reliability are investigated. The methodology for security assessment during contingency of a power system with grid support power electron-

ics is developed. It includes the definition of scenarios which lead to the load shedding events in the power system, their impact level and probability. The resulting grid frequency under different grid support capabilities of power converters is also presented. The analysis results show that significant improvements in the power system security can be achieved by power electronics grid support functionalities.

6.2 Main Contributions

The main contributions of the Ph.D. project based on the major research outcomes are listed below:

Model for cost and reliability evaluation of power electronics-based power system

A new model which includes the interaction of power electronics reliability (based on the PoF approach), power system reliability and cost is developed. It accounts for different time scales and aspects to evaluate the aforementioned elements. The model can be used to directly evaluate the reliability impact of the designed system on the cost development over time. Furthermore, it can be employed to assess the different environmental and operating impacts on the power electronics reliability and power system reliability.

Design guidelines incorporating power electronics reliability into long-term planning of power systems including optimization

New design guidelines for long-term planning, which enable power electronics reliability investigation are defined. They include long-term forecasting and sizing procedures. The developed long-term forecasting method predicts with a high level of accuracy the generation capacity used for system sizing as well as the power electronics lifetime. Those parameters can then be used in the long-term system sizing. To that extent, an optimization process for long-term power system sizing, which incorporates power electronics lifetime into the decision-making process is developed. Moreover, the impact of different external factors and operating conditions on the power electronics reliability and sizing decisions is provided.

Procedure for evaluation of power converter grid support capabilities during power system contingency

A new assessment procedure for smart inverter benefits during power system contingency is developed. The procedure provides detailed guidelines on how to define scenarios which lead to load-shedding events, as well as how to define the severity and probability of such events. Furthermore, reliability results for power systems with different grid support functionalities

provided by power electronics are analysed. They can be used for reinforcement of the existing power system or planning a future power system with increased security.

6.3 Research Prospects

Even though the main outcomes of this Ph.D. project lead to the design of a more reliable and cost-effective power electronics-based power system, there are still many research aspects that can be considered to further improve such design.

- To facilitate higher reliability of the power system during operation, it is necessary to fully exploit the grid support functionalities of smart inverters. In this Ph.D. thesis, those benefits are investigated during load-shedding conditions in the power system. In the future, it is necessary to investigate other events during operation, where smart inverters can aid power system security. To that extent, it is necessary to provide detailed guidelines for the assessment of those benefits and to integrate them into the power system planning studies.
- The forecasting method for power electronics lifetime prediction shows to outperform common state-of-the-art approaches. Nonetheless, it is necessary to investigate its accuracy for a variety of installation sites and power converter topologies. In such a way, a more robust and comprehensive forecasting tool can be obtained. The results of this study could help in reducing uncertainties in long-term power system planning. Moreover, the application of the proposed guideline for an extensive number of power converters in a large power system needs to be done. The implementation characteristics and computational requirements should be analysed in detail.
- Previous research has shown that including power electronics reliability positively impacts power system reliability. In this Ph.D. project, guidelines and models are developed to accurately evaluate and include power electronics reliability in power system planning. Nonetheless, it is still necessary to investigate the extent of adequacy improvement for different penetration levels of power electronics-based units. Similar research is also necessary for various system configurations, installation sites and operating conditions, given the framework provided in this Ph.D.
- In this Ph.D. project, power converter reliability assessment included only thermal-related failure mechanisms of power devices. In the future,

6.3. Research Prospects

it would be worth investigating the influence of other failure mechanisms (such as humidity and cosmic rays) on the design solutions. Similarly, it would be beneficial to include the failure of other power converter components (e.g. capacitors) in the reliability framework. In addition, other failures, aside from wear-out, should be considered. Including those aspects can further reduce the power electronics reliability-related uncertainties in the power system planning.

- The guidelines proposed in this Ph.D. thesis are demonstrated on several examples through the simulations. Nonetheless, it is equally important to develop the procedure for their validation on the physical system. To that extent, it is also required to develop the electrical and reliability models of other components of the power system (power lines, transformers, etc.) and include them in the proposed procedures.

Bibliography

References

- [1] United Nations (UN), “The Sustainable Development Goals Report 2022,” 2023. [Online]. Available: <https://unstats.un.org/sdgs/report/2022/>. Accessed: April. 20, 2023.
- [2] International Energy Agency (IEA), “Renewables 2022,” 2023. [Online]. Available: <https://www.iea.org/reports/renewables-2022>. Accessed: April. 20, 2023.
- [3] REN21, “Renewables global status report 2022,” 2023. [Online]. Available: <https://www.ren21.net/reports/global-status-report/>. Accessed: April. 20, 2023.
- [4] International Renewable Energy Agency (IRENA), “World energy transitions outlook 2022,” 2022. [Online]. Available: <https://www.irena.org/publications/2022/mar/world-energy-transitions-outlook-2022>. Accessed: April. 20, 2023.
- [5] European Environmental Agency (EEA), “Share of energy consumption from renewable sources in Europe,” 2023. [Online]. Available: <https://www.eea.europa.eu/ims/share-of-energy-consumption-from>. Accessed: April. 20, 2023.
- [6] Energinet, “Annual magazine 2023 - get up to speed on the green transition,” 2023. [Online]. Available: <https://en.energinet.dk/about-our-reports/reports/annual-magazine-2023/>. Accessed: April. 20, 2023.
- [7] S. Peyghami, P. Palensky, M. Fotuhi-Firuzabad, and F. Blaabjerg, “System-level design for reliability and maintenance scheduling in modern power electronic-based power systems,” *IEEE Open Access J. Power Energy*, vol. 7, pp. 414–429, 2020.

References

- [8] Electric Power Research Institute (EPRI), "Enhancing energy system reliability and resiliency in a net-zero economy," 2023. [Online]. Available: <http://mydocs.epri.com/docs/public/EPRI-Report-EnhancingEnergySystemReliability-20210804.pdf> Accessed: April 21, 2023.
- [9] S. Yang, A. Bryant, P. Mawby, D. Xiang, L. Ran, and P. Tavner, "An industry-based survey of reliability in power electronic converters," in *Proc. of ECCE*, San Jose, CA, USA, 2009, pp. 3151–3157.
- [10] System Performance, Availability and Reliability Trend Analysis (SPARTA), "Portfolio review 2016," 2017. [Online]. Available: <https://www.sparta-offshore.com>. Accessed: April 21, 2023.
- [11] Y. Lin, L. Tu, H. Liu, and W. Li, "Fault analysis of wind turbines in China," *Renew. Sust. Energ.*, vol. 55, pp. 482–490, 2016.
- [12] Kiwa, "Addressing the challenges of string inverter failures in solar PV systems," 2021. [Online]. Available: <https://www.kiwa.com/nl/en/>. Accessed: April 21, 2023.
- [13] F. Spertino, E. Chiodo, A. Ciocia, G. Malgaroli, and A. Ratclif, "Maintenance activity, reliability, availability, and related energy losses in ten operating photovoltaic systems up to 1.8 MW," *IEEE Trans. Ind. Appl.*, vol. 57, no. 1, pp. 83–93, 2021.
- [14] M. Schmidthaler and J. Reichl, "Assessing the socio-economic effects of power outages ad hoc," *Comput. Sci. Res. Dev.*, vol. 31, pp. 157–161, 2016.
- [15] U.S.-Canda Power System Outage Task Force, "Final Report on the August 14, 2003 Blackout in the United States and Canada: Causes and Recommendations," 2004. [Online]. Available: <https://www.energy.gov/oe/articles/blackout-2003-final-report-august-14-2003-blackout-united-states-and-canada-causes-and>. Accessed: April 21, 2023.
- [16] CRO Forum, "Power blackout risks," 2011. [Online]. Available: <https://www.thecroforum.org/wp-content/uploads/2012/09/CRO-Position-Paper-Power-Blackout-Risks-1-1.pdf>. Accessed: April 21, 2023.
- [17] S. Peyghami, P. Davari, M. Fotuhi-Firuzabad, and F. Blaabjerg, "Standard test systems for modern power system analysis: An overview," *IEEE Ind. Electron. Mag.*, vol. 13, no. 4, pp. 86–105, 2019.

References

- [18] L. L. Grigsby, *Power System Stability and Control*. Taylor & Francis, New York, 2007.
- [19] N. Hatziaargyriou, J. Milanovic, C. Rahmann, V. Ajjarapu, C. Canizares, I. Erlich, D. Hill, I. Hiskens, I. Kamwa, B. Pal, P. Pourbeik, J. Sanchez-Gasca, A. Stankovic, T. Van Cutsem, V. Vittal, and C. Vournas, "Definition and classification of power system stability – revisited & extended," *IEEE Trans. Power Syst.*, vol. 36, no. 4, pp. 3271–3281, 2021.
- [20] S. Peyghami, P. Palensky, and F. Blaabjerg, "An overview on the reliability of modern power electronic based power systems," *IEEE Open J. Power Electron.*, vol. 1, pp. 34–50, 2020.
- [21] "IEEE Recommended Practice for the Planning and Design of the Microgrid," *IEEE Std 2030.9-2019*, pp. 1–46, 2019.
- [22] A. Ahadi, N. Ghadimi, and D. Mirabbasi, "Reliability assessment for components of large scale photovoltaic systems," *J. Power Sources*, vol. 264, pp. 211–219, 2014.
- [23] B. Zhang, M. Wang, and W. Su, "Reliability analysis of power systems integrated with high-penetration of power converters," *IEEE Trans. Power Syst.*, vol. 36, no. 3, pp. 1998–2009, 2021.
- [24] Y. Guo, H. Gao, and Q. Wu, "A combined reliability model of VSC-HVDC connected offshore wind farms considering wind speed correlation," *IEEE Trans. Sustain. Energy*, vol. 8, no. 4, pp. 1637–1646, 2017.
- [25] P. Carton, M. Giraudeau, and F. Davenel, "New FIDES models for emerging technologies," in *Proc. of RAMS*, Orlando, FL, USA, 2017, pp. 1–6.
- [26] "The future of reliability - definition of reliability in light of new developments in various devices and services which offer customers and system operators new levels of flexibility," Tech. Rep. 715, Cigre Working Group C6.27, 2018.
- [27] S. Peyghami and F. Blaabjerg, "Demands for bridging power electronics and power system engineering concepts," in *Proc. of eGRID*, Aachen, Germany, 2020, pp. 1–8.
- [28] S. Peyghami, F. Blaabjerg, and P. Palensky, "Incorporating power electronic converters reliability into modern power system reliability analysis," *IEEE Emerg. Sel. Topics Power Electron.*, vol. 9, no. 2, pp. 1668–1681, 2021.

References

- [29] Y. Yang, A. Sangwongwanich, and F. Blaabjerg, "Design for reliability of power electronics for grid-connected photovoltaic systems," *CPSS Trans. Power Electron. Appl.*, vol. 1, no. 1, pp. 92–103, 2016.
- [30] K. Ma, H. Wang, and F. Blaabjerg, "New approaches to reliability assessment: Using physics-of-failure for prediction and design in power electronics systems," *IEEE Power Electron. Mag.*, vol. 3, no. 4, pp. 28–41, 2016.
- [31] H. Wang, F. Blaabjerg, K. Ma, and R. Wu, "Design for reliability in power electronics in renewable energy systems – status and future," in *Proc. of POWERENG*, Istanbul, Turkey, 2013, pp. 1846–1851.
- [32] A. Davoodi, Y. Yang, T. Dragicevic, and F. Blaabjerg, "System-level reliability analysis of a repairable power electronic-based power system considering non-constant failure rates," in *Proc. of EPE'20 ECCE Europe*, Lyon, France, 2020, pp. 1–10.
- [33] A. Khodaei, S. Bahramirad, and M. Shahidehpour, "Microgrid planning under uncertainty," *IEEE Trans. Power Syst.*, vol. 30, no. 5, pp. 2417–2425, 2015.
- [34] H. Lotfi and A. Khodaei, "AC versus DC microgrid planning," *IEEE Trans. Smart Grid*, vol. 8, no. 1, pp. 296–304, 2017.
- [35] H. Baghaee, M. Mirsalim, G. Gharehpetian, and H. Talebi, "Reliability/cost-based multi-objective Pareto optimal design of stand-alone wind/PV/FC generation microgrid system," *Energy*, vol. 115, pp. 1022–1041, 2016.
- [36] National Renewable Energy Laboratory (NREL), "U.S solar photovoltaic system and energy storage cost benchmark: Q1 2020," Tech. Rep. No. NREL/TP-6A20-77324, 2021.
- [37] V. K. Garg, S. Sharma, and D. Kumar, "Design and analysis of a microgrid system for reliable rural electrification," *Int. Trans. Electr. Energy Syst.*, vol. 31, no. 2, pp. 1–20, 2021.
- [38] G. Si, T. Xia, N. Gebraeel, D. Wang, E. Pan, and L. Xi, "A reliability-and-cost-based framework to optimize maintenance planning and diverse-skilled technician routing for geographically distributed systems," *Reliab. Eng. Syst. Saf.*, vol. 226, pp. 108 652–108 666, 2022.
- [39] A. Khodaei and M. Shahidehpour, "Microgrid-based co-optimization of generation and transmission planning in power systems," *IEEE Trans. Power Syst.*, vol. 28, no. 2, pp. 1582–1590, 2013.

References

- [40] F. He, Z. Zhao, and L. Yuan, "Impact of inverter configuration on energy cost of grid-connected photovoltaic systems," *J. Renewable Energy*, vol. 41, pp. 328–335, 2012.
- [41] D. Wang, H. Wang, and X. Zhang, "Mission profile-oriented configuration of PV panels for lifetime and cost-efficiency of PV inverters," *Microelectron. Reliab.*, vol. 114, pp. 113 944–113 948, 2020.
- [42] D. Fioriti, D. Poli, P. Duenas-Martinez, and I. Perez-Arriaga, "Multi-year stochastic planning of off-grid microgrids subject to significant load growth uncertainty: Overcoming single-year methodologies," *Electr. Power Syst. Res.*, vol. 194, pp. 107 053–107 063, 2021.
- [43] International Renewable Energy Agency (IRENA), "Future of solar photovoltaic: Deployment, investment, technology, grid integration and socio-economic aspects (a global energy transformation paper)," Abu Dhabi, 2019.
- [44] P. Machado, L. E. de Souza, and R. S. Netto, "Framework to support grid-connected microgrid optimal planning," in *Proc. of IEEE IC/ICPS Europe*, Palermo, Italy, 2018, pp. 1–6.
- [45] C. A. Cortes, S. F. Contreras, and M. Shahidehpour, "Microgrid topology planning for enhancing the reliability of active networks," *IEEE Trans. Smart Grid*, vol. 9, no. 6, pp. 6369–6377, 2018.
- [46] A. M. Nakiganda, S. Dehghan, and P. Aristidou, "Enhancing microgrid resilience and survivability under static and dynamic islanding constraints," in *Proc. of ISGT-Europe*, Delft, The Netherlands, 2020, pp. 539–543.
- [47] S. Chalil Madathil, E. Yamangil, H. Nagarajan, A. Barnes, R. Bent, S. Backhaus, S. J. Mason, S. Mashayekh, and M. Stadler, "Resilient off-grid microgrids: Capacity planning and N-1 security," *IEEE Trans. Smart Grid*, vol. 9, no. 6, pp. 6511–6521, 2018.
- [48] A. K. Basu, "Microgrids: Planning of fuel energy management by strategic deployment of CHP-based DERs – an evolutionary algorithm approach," *Int. J. Electr. Power Energy Syst.*, vol. 44, no. 1, pp. 326–336, 2013.
- [49] Y.-Y. Hong, W.-C. Chang, Y.-R. Chang, Y.-D. Lee, and D.-C. Ouyang, "Optimal sizing of renewable energy generations in a community microgrid using Markov model," *Energy*, vol. 135, pp. 68–74, 2017.
- [50] C. Yuan, G. Liu, Z. Wang, X. Chen, and M. S. Illindala, "Economic power capacity design of distributed energy resources for reliable community microgrids," *Energy Procedia*, vol. 142, pp. 2561–2567, 2017.

References

- [51] S. R. Khuntia, J. L. Rueda, and M. A. M. M. van der Meijden, "Volatility in electrical load forecasting for long-term horizon — an ARIMA-GARCH approach," in *Proc. of PMAPS*, Beijing, China, 2016, pp. 1–6.
- [52] S. Jung, J. Jeoung, H. Kang, and T. Hong, "Optimal planning of a rooftop PV system using GIS-based reinforcement learning," *Appl. Energy*, vol. 298, pp. 117 239–117 251, 2021.
- [53] S. Swaminathan, G. S. Pavlak, and J. Freihaut, "Sizing and dispatch of an islanded microgrid with energy flexible buildings," *Appl. Energy*, vol. 276, pp. 115 355–115 365, 2020.
- [54] V. Amir, M. Azimian, and A. S. Razavizadeh, "Reliability-constrained optimal design of multicarrier microgrid," *Int. Trans. Electr. Energy Syst.*, vol. 29, no. 12, pp. 1–20, 2019.
- [55] A. Sangwongwanich, Y. Yang, D. Sera, F. Blaabjerg, and D. Zhou, "On the impacts of PV array sizing on the inverter reliability and lifetime," *IEEE Trans. Ind Appl.*, vol. 54, no. 4, pp. 3656–3667, 2018.
- [56] M. Sandelic, A. Sangwongwanich, and F. Blaabjerg, "Robustness evaluation of PV-battery sizing principle under mission profile variations," in *Proc. of ECCE*, Detroit, MI, USA, 2020, pp. 545–552.
- [57] H. Wen, Y. Du, X. Chen, E. Lim, H. Wen, L. Jiang, and W. Xiang, "Deep learning based multistep solar forecasting for PV ramp-rate control using sky images," *IEEE Trans. Industr. Inform.*, vol. 17, no. 2, pp. 1397–1406, 2021.
- [58] T. Yao, J. Wang, H. Wu, P. Zhang, S. Li, K. Xu, X. Liu, and X. Chi, "Intra-hour photovoltaic generation forecasting based on multi-source data and deep learning methods," *IEEE Trans. Sustain. Energy*, vol. 13, no. 1, pp. 607–618, 2022.
- [59] R. Zhang, H. Ma, W. Hua, T. K. Saha, and X. Zhou, "Data-driven photovoltaic generation forecasting based on a Bayesian network with spatial-temporal correlation analysis," *IEEE Trans. Industr. Inform.*, vol. 16, no. 3, pp. 1635–1644, 2020.
- [60] J. Xie and T. Hong, "Temperature scenario generation for probabilistic load forecasting," *IEEE Trans. Smart Grid*, vol. 9, no. 3, pp. 1680–1687, 2018.
- [61] Y. Zhang, C. Cheng, H. Cai, X. Jin, Z. Jia, X. Wu, H. Su, and T. Yang, "Long-term stochastic model predictive control and efficiency assessment for hydro-wind-solar renewable energy supply system," *Appl. Energy*, vol. 316, pp. 119 134–119 148, 2022.

References

- [62] J.-H. Kim, P. A. Jimenez Munoz, M. Sengupta, J. Yang, J. Dudhia, S. Alessandrini, and Y. Xie, "The WRF-solar ensemble prediction system to provide solar irradiance probabilistic forecasts," *IEEE J. Photovolt.*, vol. 12, no. 1, pp. 141–144, 2022.
- [63] J. F. Jønler, F. Brunø Lottrup, B. Berg, D. Zhang, and K. Chen, "Probabilistic forecasts of global horizontal irradiance for solar systems," *IEEE Sens. Lett.*, vol. 7, no. 1, pp. 1–4, 2023.
- [64] S. Abedi, A. Alimardani, G. Gharehpetian, G. Riahy, and S. Hosseini, "A comprehensive method for optimal power management and design of hybrid RES-based autonomous energy systems," *Renew. Sust. Energ. Rev.*, vol. 16, no. 3, pp. 1577–1587, 2012.
- [65] A. Sangwongwanich, Y. Yang, D. Sera, and F. Blaabjerg, "Mission profile-oriented control for reliability and lifetime of photovoltaic inverters," *IEEE Trans. Ind Appl.*, vol. 56, no. 1, pp. 601–610, 2020.
- [66] M. Anvari, G. Lohmann, M. Wächter, P. Milan, E. Lorenz, D. Heine mann, M. R. R. Tabar, and J. Peinke, "Short term fluctuations of wind and solar power systems," *New J. Phys.*, vol. 18, no. 6, pp. 63 027–63 048, 2016.
- [67] P. S. Kundur and O. Malik, *Power System Stability and Control, Second Edition*. McGraw Hill Education, New York, 2022.
- [68] B. Qin, M. Wang, G. Zhang, and Z. Zhang, "Impact of renewable energy penetration rate on power system frequency stability," *Energy Rep.*, vol. 8, pp. 997–1003, 2022.
- [69] X. Sun, J. Qiu, Y. Yi, and Y. Tao, "Cost-effective coordinated voltage control in active distribution networks with photovoltaics and mobile energy storage systems," *IEEE Trans. Sustainable Energy*, vol. 13, no. 1, pp. 501–513, 2022.
- [70] A. Ulbig, T. S. Borsche, and G. Andersson, "Impact of low rotational inertia on power system stability and operation," *IFAC Proceedings Volumes*, vol. 47, no. 3, pp. 7290–7297, 2014.
- [71] S. Xu, Y. Xue, and L. Chang, "Review of power system support functions for inverter-based distributed energy resources- standards, control algorithms, and trends," *IEEE Open J. Power Electron.*, vol. 2, pp. 88–105, 2021.
- [72] National Renewable Energy Laboratory (NREL), "Integrating More Solar with Smart Inverters," Tech. Rep. No. NREL/CP-5D00-71766, 2018.

References

- [73] Y. Han, H. Li, P. Shen, E. A. A. Coelho, and J. M. Guerrero, "Review of active and reactive power sharing strategies in hierarchical controlled microgrids," *IEEE Trans. Power Electron.*, vol. 32, no. 3, pp. 2427–2451, 2017.
- [74] Electric Power Research Institute (EPRI), "Advanced grid support functions for smart inverters," 2023. [Online]. Available: <https://www.epri.com/research/products/000000003002003288> Accessed: May 3, 2023.
- [75] Y. Yang, *Advanced Control Strategies to Enable a More Wide-Scale Adoption of Single-Phase Photovoltaic Systems*. Ph.D. dissertation, Department of Energy Technology, Aalborg University, 2014.
- [76] F. Blaabjerg, A. Sangwongwanich, and Y. Yang, "Chapter 6 - Flexible Power Control of Photovoltaic Systems," in *Advances in Renewable Energies and Power Technologies*, I. Yahyaoui, Ed. Elsevier, 2018, pp. 207–229.
- [77] E. Gatavi, A. Hellany, M. Nagrial, and J. Rizk, "An integrated reactive power control strategy for improving low voltage ride-through capability," *Chin. J. Electr. Eng.*, vol. 5, no. 4, pp. 1–14, 2019.
- [78] J. Johnson, J. C. Neely, J. J. Delhotal, and M. Lave, "Photovoltaic frequency-watt curve design for frequency regulation and fast contingency reserves," *IEEE J. Photovolt.*, vol. 6, no. 6, pp. 1611–1618, 2016.
- [79] A. M. Howlader, S. Sadoyama, L. R. Roose, and Y. Chen, "Active power control to mitigate voltage and frequency deviations for the smart grid using smart PV inverters," *Appl. Energy*, vol. 258, pp. 114 000–114 015, 2020.
- [80] K. Shinoda, A. Benchaib, J. Dai, and X. Guillaud, "Over- and under-voltage containment reserves for droop-based primary voltage control of MTDC grids," *IEEE Trans. Power Delivery*, vol. 37, no. 1, pp. 125–135, 2022.
- [81] S. Weckx, C. Gonzalez, and J. Driesen, "Combined central and local active and reactive power control of PV inverters," *IEEE Trans. Sustainable Energy*, vol. 5, no. 3, pp. 776–784, 2014.
- [82] M. Sandelic, A. Sangwongwanich, and F. Blaabjerg, "Impact of power converters and battery lifetime on return of investment of photovoltaic systems," in *Proc. of IPEMC2020-ECCE Asia*, Nanjing, China, 2020, pp. 1395–1401.
- [83] R. Billinton and R. N. Allan, *Reliability Evaluation of Power Systems*. Plenum Press, New York, 1996.

References

- [84] J. Nelson, N. G. Johnson, K. Fahy, and T. A. Hansen, "Statistical development of microgrid resilience during islanding operations," *Appl. Energy*, vol. 279, pp. 115724–115738, 2020.
- [85] H. Wu, X. Liu, and M. Ding, "Dynamic economic dispatch of a microgrid: Mathematical models and solution algorithm," *Int. J. Elec. Power*, vol. 63, pp. 336–346, 2014.
- [86] J. Teh, C.-M. Lai, and Y.-H. Cheng, "Impact of the real-time thermal loading on the bulk electric system reliability," *IEEE Trans. Reliab.*, vol. 66, no. 4, pp. 1110–1119, 2017.
- [87] R. Bayerer, T. Herrmann, T. Licht, J. Lutz, and M. Feller, "Model for power cycling lifetime of IGBT modules - various factors influencing lifetime," in *Proc. of CIPS*, Nuremberg, Germany, 2008, pp. 1–6.
- [88] M. Musallam and C. M. Johnson, "An efficient implementation of the rainflow counting algorithm for life consumption estimation," *IEEE Trans. Reliab.*, vol. 61, no. 4, pp. 978–986, 2012.
- [89] A. Davoodi, Y. Yang, T. Dragičević, and F. Blaabjerg, "System-level reliability analysis of a repairable power electronic-based power system considering non-constant failure rates," in *Proc. of EPE'20 ECCE Europe*, Lyon, France, 2020, pp. 1–10.
- [90] A. Davoodi, S. Peyghami, Y. Yang, T. Dragičević, and F. Blaabjerg, "System-level design for reliability of microgrids considering power electronic failures," in *Proc. of PEDG*, Kiel, Germany, 2022, pp. 1–6.
- [91] A. Davoodi, S. Peyghami, Y. Yang, T. Dragicevic, and F. Blaabjerg, "Fast and accurate modeling of power converter availability for adequacy assessment," *IEEE Trans. Power Deliv.*, vol. 36, no. 6, pp. 3992–3995, 2021.
- [92] A. Naderipour, H. Saboori, H. Mehrjerdi, S. Jadid, and Z. Abdul-Malek, "Sustainable and reliable hybrid AC/DC microgrid planning considering technology choice of equipment," *Sustain. Energy, Grids Netw.*, vol. 23, pp. 100386–100400, 2020.
- [93] D. Sera, R. Teodorescu, and P. Rodriguez, "PV panel model based on datasheet values," in *Proc. of ISIE*, Vigo, Spain, 2007, pp. 2392–2396.
- [94] M. Sandelic, D.-I. Stroe, and F. Iov, "Battery storage-based frequency containment reserves in large wind penetrated scenarios: A practical approach to sizing," *Energies*, vol. 11, no. 11, pp. 3065–3084, 2018.

References

- [95] J. P. Carvallo, P. H. Larsen, A. H. Sanstad, and C. A. Goldman, "Long term load forecasting accuracy in electric utility integrated resource planning," *Energy Policy*, vol. 119, pp. 410–422, 2018.
- [96] J. Faraji, H. Hashemi-Dezaki, and A. Ketabi, "Multi-year load growth-based optimal planning of grid-connected microgrid considering long-term load demand forecasting: A case study of Tehran, Iran," *Sustain. Energy Technol. Assess.*, vol. 42, pp. 100 827–100 846, 2020.
- [97] A. Sangwongwanich, D. Zhou, E. Liivik, and F. Blaabjerg, "Mission profile resolution impacts on the thermal stress and reliability of power devices in PV inverters," *Microelectron. Reliab.*, vol. 88-90, pp. 1003–1007, 2018.
- [98] Y. Yang, W. Li, T. A. Gulliver, and S. Li, "Bayesian deep learning-based probabilistic load forecasting in smart grids," *IEEE Trans. Industr. Inform.*, vol. 16, no. 7, pp. 4703–4713, 2020.
- [99] Y. Quek, W. Woo, and T. Logenthiran, "A Naïve Bayes classification approach for short-term forecast of a photovoltaic system," in *Proc. of SEES*, Singapore, Singapore, 2017, pp. 1–6.
- [100] U. Maulik and S. Bandyopadhyay, "Performance evaluation of some clustering algorithms and validity indices," *EEE Trans. Pattern Anal. Mach. Intell.*, vol. 24, no. 12, pp. 1650–1654, 2002.
- [101] Y. Kurdi, B. J. Alkhatatbeh, S. Asadi, and H. Jebelli, "A decision-making design framework for the integration of PV systems in the urban energy planning process," *Renew. Energy*, vol. 197, pp. 288–304, 2022.
- [102] J. H. Yi, R. Cherkaoui, M. Paolone, D. Shchetinin, and K. Knezovic, "Expansion planning of active distribution networks achieving their dispatchability via energy storage systems," *Appl. Energy*, vol. 326, pp. 119 942–119 956, 2022.
- [103] Q. Sun, Z. Wu, W. Gu, T. Zhu, L. Zhong, and T. Gao, "Flexible expansion planning of distribution system integrating multiple renewable energy sources: An approximate dynamic programming approach," *Energy*, vol. 226, p. 120367, 2021.
- [104] G. Merei, J. Moshövel, D. Magnor, and D. U. Sauer, "Optimization of self-consumption and techno-economic analysis of PV-battery systems in commercial applications," *Appl. Energy*, vol. 168, pp. 171 – 178, 2016.
- [105] A. I. Nousdilis, G. C. Kryonidis, E. O. Kontis, G. K. Papagiannis, G. C. Christoforidis, and I. P. Panapakidis, "Economic viability of residential PV systems with battery energy storage under different incentive schemes," in *Proc. of EEEIC / I CPS Europe*, Palermo, Italy, 2018, pp. 1–6.

References

- [106] R. A. Chadderton, *Purposeful Engineering Economics*. Springer, Springer, 2015.
- [107] G. Angenendt, S. Zurmühlen, H. Axelsen, and D. U. Sauer, "Comparison of different operation strategies for PV battery home storage systems including forecast-based operation strategies," *Appl. Energy*, vol. 229, pp. 884 – 899, 2018.
- [108] Y. Li and J. Wu, "Optimum integration of solar energy with battery energy storage systems," *IEEE Trans. Eng. Manag.*, vol. 69, no. 3, pp. 697–707, 2022.
- [109] I. A. Ibrahim and M. Hossain, "A benchmark model for low voltage distribution networks with PV systems and smart inverter control techniques," *Renew. Sust. Energ. Rev.*, vol. 166, pp. 112 571–112 594, 2022.
- [110] N. Guruwacharya, N. Bhujel, T. M. Hansen, S. Suryanarayanan, R. Tonkoski, U. Tamrakar, and F. Wilches-Bernal, "Modeling inverters with grid support functions for power system dynamics studies," in *Proc. of ISGT*, Washington, DC, 2021, pp. 1–5.
- [111] "IEEE standard for interconnection and interoperability of distributed energy resources with associated electric power systems interfaces," *IEEE Std 1547-2018 (Revision of IEEE Std 1547-2003)*, pp. 1–138, 2018.
- [112] National Renewable Energy Laboratory (NREL), "Final Technical Report: Multi-Timescale Integrated Dynamics and Scheduling for Solar (MIDAS-Solar)," Tech. Rep. No. NREL/TP-5D00-85679, 2023.
- [113] Y.-Y. Hong, M.-C. Hsiao, Y.-R. Chang, Y.-D. Lee, and H.-C. Huang, "Multiscenario underfrequency load shedding in a microgrid consisting of intermittent renewables," *IEEE Trans. Power Deliv.*, vol. 28, no. 3, pp. 1610–1617, 2013.

ISSN (online): 2446-1636
ISBN (online): 978-87-7573-618-8

AALBORG UNIVERSITY PRESS