



Aalborg Universitet

AALBORG UNIVERSITY  
DENMARK

## Optimization with System Damping Restoration for Droop Controlled DC-DC Converters

Meng, Lexuan; Dragicevic, Tomislav; Guerrero, Josep M.; Vasquez, Juan Carlos

*Published in:*

Proceedings of the IEEE Energy Conversion Congress and Exposition, ECCE 2013

*DOI (link to publication from Publisher):*

[10.1109/ECCE.2013.6646682](https://doi.org/10.1109/ECCE.2013.6646682)

*Publication date:*

2013

*Document Version*

Early version, also known as pre-print

[Link to publication from Aalborg University](#)

*Citation for published version (APA):*

Meng, L., Dragicevic, T., Guerrero, J. M., & Vasquez, J. C. (2013). Optimization with System Damping Restoration for Droop Controlled DC-DC Converters. In *Proceedings of the IEEE Energy Conversion Congress and Exposition, ECCE 2013* (pp. 65-72). IEEE Press. <https://doi.org/10.1109/ECCE.2013.6646682>

### General rights

Copyright and moral rights for the publications made accessible in the public portal are retained by the authors and/or other copyright owners and it is a condition of accessing publications that users recognise and abide by the legal requirements associated with these rights.

- Users may download and print one copy of any publication from the public portal for the purpose of private study or research.
- You may not further distribute the material or use it for any profit-making activity or commercial gain
- You may freely distribute the URL identifying the publication in the public portal -

### Take down policy

If you believe that this document breaches copyright please contact us at [vbn@aub.aau.dk](mailto:vbn@aub.aau.dk) providing details, and we will remove access to the work immediately and investigate your claim.

# Optimization with System Damping Restoration for Droop Controlled DC-DC Converters

Lexuan Meng, Tomislav Dragicevic, Josep M. Guerrero, Juan C. Vásquez

Dept. of Energy Technology  
Aalborg University  
Aalborg, Denmark

[lme@et.aau.dk](mailto:lme@et.aau.dk) , [tdr@et.aau.dk](mailto:tdr@et.aau.dk) , [joz@et.aau.dk](mailto:joz@et.aau.dk) , [juq@et.aau.dk](mailto:juq@et.aau.dk)

**Abstract**—The parallel operation of dc-dc converters is widely used in distribution systems and uninterruptable power supply systems. Droop control along with virtual resistance (VR) is considered a simple and reliable method for achieving wireless power sharing among converters. In order to enhance the efficiency of the conversion system, this paper implements tertiary level optimization control on the basis of hierarchical control. As the efficiency of each converter changes with output power, VRs are set as decision variables for adjusting power sharing proportion among converters. Genetic algorithm is used in searching for global efficiency optimum. However system dynamic is affected when shifting VRs. Therefore, the stability of a parallel buck converter system is analyzed to examine the influence of VR changing on system dynamics. Based on the stability analysis, a system damping secondary restoration (SDSR) is implemented to readjust the optimization results so as to ensure system stability. Simulation results are shown to demonstrate the improvement of system efficiency and effectiveness of the method.

operation of dc-dc converters (see Fig. 1) have been widely used in various applications in power distribution or conversion applications, as it gives many advantages. Some of the notable ones are enhanced flexibility, reduced thermal and electric stress, improved reliability and so forth [1].

One challenging issue is the power sharing control among paralleling units. Up to date, several kinds of current sharing approaches were proposed, among which master-slave and droop are the two most popular methods [2]. Since droop control is a decentralized strategy which does not require communication links and offers higher reliability and flexibility, it is preferred [4] in multi-converter systems.

Although the dc voltage droop control facilitates autonomous power sharing among paralleled converters, in its basic form it does not guarantee an efficient operation of the system. Converter efficiency is related with its operation point which finally influences the system losses [6]. Operation points for converters can be optimized so as to achieve higher system efficiency.

However, stability issues may appear when droop parameters (also termed virtual resistances (VRs) [5]) are altered [7]. As the bandwidth of optimization control is usually much lower than inner loops and droop controller, the optimization for adjusting VRs can be performed online.

In this paper, a droop-controlled buck converter based dc-dc conversion system is taken as an example. The structure of hierarchical control method is described in section II, with droop, bus voltage restoration, system damping secondary restoration (SDSR) and optimization control being distinguished. In section III, the optimization problem is formulated and analyzed by defining the objective function and respective constraints. The algorithm is also presented and tuned. Section IV introduces a novel method for stability secondary restoration by setting a damping reference. The state space model of the system is established, root locus analysis is described. In section V,

## I. INTRODUCTION

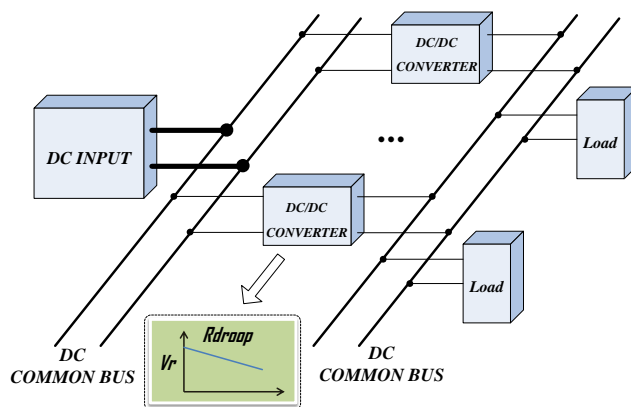

Figure 1. Droop-controlled paralleled dc-dc converter system

Direct current (dc) electricity distribution is generally accepted as high efficiency, high reliability and simple control system [1]-[5]. During last decades, parallel

simulation results are presented and discussed. Finally, Section VI gives the conclusion.

## II. OPTIMIZATION CONTROL ON A HIERARCHICAL CONTROL BASIS

Hierarchical control [5][8] was proposed for economical and stable operation of microgrids. The three control levels, primary control, secondary control and tertiary control, are integrated together to fulfill control objectives in different significances and time scales. Primary control enables power sharing among converters and defines system stability. Secondary control deals with power quality issues and controls voltage and frequency deviation, harmonics and unbalances. Tertiary control acts on set-points within the primary and secondary control and achieves optimal operation while taking into consideration both safety and economic.

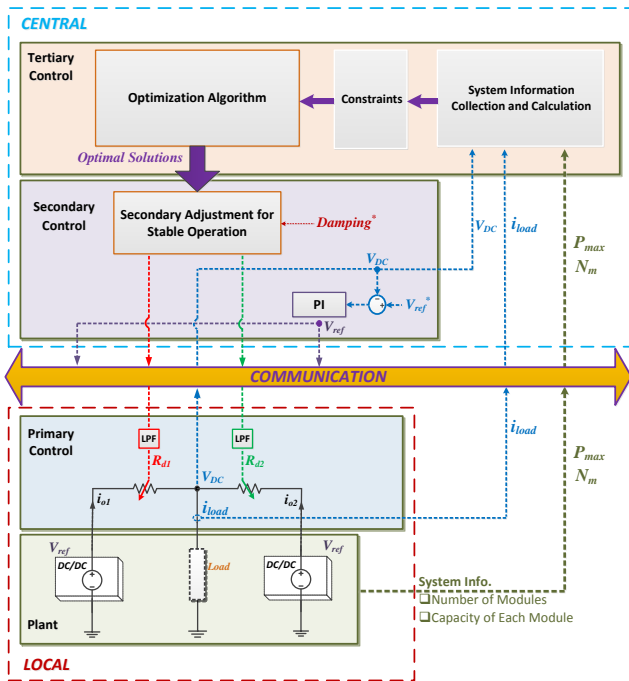

Figure 2. Hierarchical Control in DC System

The concept of hierarchical control can be mimicked into paralleled dc-dc converter system, as shown in Fig. 2. The plant block shows a simplified equivalent circuit of two dc supplies connected in parallel powering a common load bus. Droop controlled dc-dc converter acts as a voltage source in series with VR. In primary level, droop control method is implemented which include the VR expressed as follows:

$$v_{DC}^* = v_{ref} - R_d \cdot i_o \quad (1)$$

where  $i_o$  is the output current of each unit,  $R_d$  is the VR, and  $v_{ref}$  is the output voltage reference at no load. Usually VR is fixed by the maximum allowed voltage deviation  $\varepsilon$ , and maximum output current  $i_{max}$ :

$$R_d = \varepsilon_v / i_{max} \quad (2)$$

Primary loop ensures power sharing and stable operation, however, according to (1), the voltage deviation is inherent and depends on load current. In order to solve this problem, secondary control is implemented. The dc bus voltage is sensed and compared with desired voltage  $v^*$ , with the difference being sent to a PI (Portional-Integral) controller to generate a compensating quantity  $\delta v$  for each converter reference:

$$\delta v = k_p (v^* - v_{DC}) + k_i \int (v^* - v_{DC}) dt \quad (3)$$

$$v_{DC}^* = v_{ref} + \delta v - R_d \cdot i_o \quad (4)$$

Ultimately, tertiary level receives system data including the number of operation modules, the conversion capability of each module and load current measurement. Received information is processed by optimization algorithm to find the optimal sharing proportion of load current. VR is the actual controlled variable for adjusting sharing efforts of each unit. However, in order to keep stable operation while changing VR, a secondary adjustment is implemented for restore the system to a desired damping level. Also, a low pass filter (LPF) is required between higher level regulation and primary droop to smooth the shifting of VR.

It is noteworthy that secondary is important when considering higher level controls. Because of the low bandwidth of tertiary level regulation, without secondary control it may not be able to fast restore voltage deviation caused by droop control and stochastic load changing. In this sense, secondary control provides significant support to stabilize bus voltage. Low pass filters with different time constant are essential for differentiate regulation speed of secondary and tertiary control.

## III. OPTIMIZATION PROBLEM FORMULATION AND ANALYSIS

Although modern power electronic system provides high efficiency conversion, losses are inevitable. The minimization of losses is always pursued. In a paralleling system, total losses are mostly related with conversion loss which is caused by switching, driver and filter parasitic elements in each converter. Paralleled converters normally have different efficiency curves due to different configurations and parameters. Even if constant input and output voltages are assumed, converter efficiency changes with load current, as shown in Fig. 3 [9][10]. As the highest efficiency is usually reached between 30% to 60% load, there exists a room for optimization, which is to find the power sharing proportion where the losses of the system are minimum.

### A. Converter Efficiency and Objective Function

A typical efficiency curve extracted from experimental setup is shown in Fig. 3. Matlab Curve Fitting Tool is used to transform the experimental data into function:

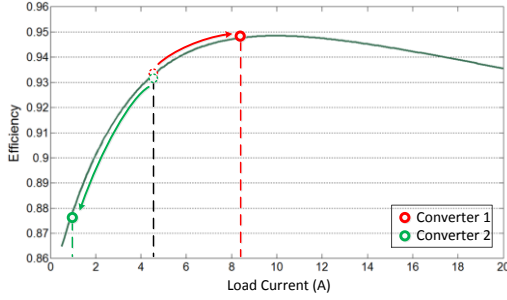

Figure 3. Typical Converter Efficiency Curve

$$\eta(i) = 0.975 \cdot e^{-2 \times 10^{-3} \cdot i} - 0.1257 \cdot e^{-0.3 \cdot i} \quad (5)$$

where  $\eta$  is converter efficiency and  $i$  is converter output current. Then the power conversion losses of a system with  $n$  paralleled converters may be calculated as follows:

$$P_{cvr\_loss} = \sum_{j=1}^n V_{DC} \cdot I_j \cdot \frac{\eta_j}{1 - \eta_j} \quad (6)$$

where  $V_{DC}$  is dc bus voltage,  $I_j$  is the output current of  $j^{\text{th}}$  converter and  $\eta_j$  is the efficiency of  $j^{\text{th}}$  converter. Minimization of system total conversion losses,  $P_{cvr\_loss}$ , is taken as the objective in the following optimization problem.

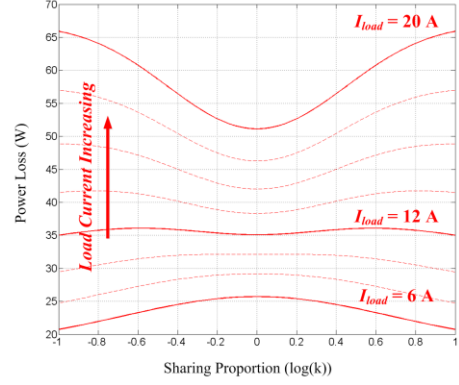

(a) System Power Loss Changing with Sharing Proportion

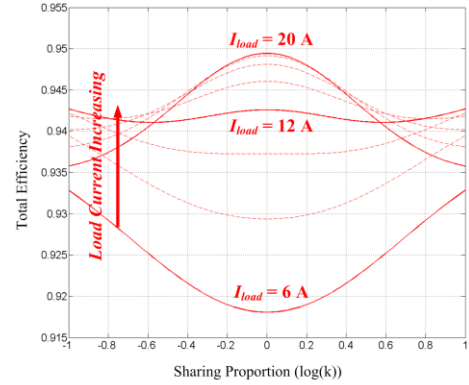

(b) System Efficiency Changing with Sharing Proportion

Figure 4. The effect of sharing proportion changing

Assuming two converters operating in parallel with the same efficiency curve as shown in Fig. 3, the general approach for enhancing system efficiency is to use only one converter in low and medium power conditions instead of equal sharing load power. A sharing proportion gain  $k$  is set to evaluate the system power loss and efficiency change, as shown in Fig. 4.

Fig. 4(a) shows the varying trends of system power losses with sharing proportion in different load current levels. In low load current level ( $I_{load} = 6A$ ), the system loss is lower when the sharing proportion is higher while in high load current level ( $I_{load} = 20A$ ) the system loss is lower when the two converters equally share the load current. Special case is in medium load current ( $I_{load} = 12A$ ) when sharing proportion changes from 0.1 to 10. The system power losses at  $k=0.1$ ,  $k=1$  and  $k=10$  are almost the same, but one can expect more decrease of system power loss if increase the sharing proportion. Fig. 4(b) shows the system efficiency changing with regard to logarithm of sharing proportion  $k$ , which is in accordance with Fig. 4(a).

Based on above discussion, by changing sharing proportion, the system efficiency can be improved.

### B. Effect of Droop Shifting and Decision Variable

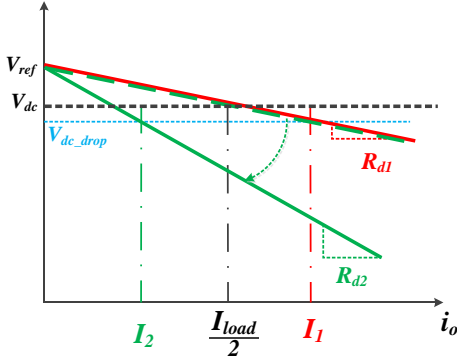

Figure 5. Sharing Proportion Adjusting by Droop Shifting

In order to change the current sharing proportion, a droop shifting method is proposed, as shown in Fig. 5. Two converters are given the same reference voltage  $v_{ref}$ . Originally, the two converters are sharing the load current equally ( $I_1=I_2=I_{load}/2$ ). If the VR of one of the converters is shifted to another value (see green line in Fig. 5), the sharing proportion is changed. Then, from Eq. (1) one can get:

$$I_j = \frac{V_{ref} - V_{DC}}{R_{dj}} \quad (7)$$

where  $I_j$  and  $R_{dj}$  is the  $j^{\text{th}}$  converter output current and VR. In a 2-converter system, the load sharing ratio is:

$$\frac{I_1}{I_2} = \frac{R_{d2}}{R_{d1}} \quad (8)$$

Accordingly, the optimization is to find an optimal proportion of load current sharing by changing VR. However, the VR shifting certainly has influence on dc bus voltage deviation and system dynamics. Also the power conversion capability of each converter should be taken into consideration.

Dc bus voltage deviation is well handled by secondary control as described in (3) and (4). System dynamics are analyzed and discussed in Section IV.

### C. Optimization Problem Formulation and Analysis

Based on the analysis above, the optimization problem can be described as:

$$\text{Objective Function: } \text{Min} \{ P_{cvr\_loss} \} \quad (9)$$

$$\text{Decision Variables: } \{ R_{d1}, R_{d2}, \dots, R_{dn} \} \quad (10)$$

$$\text{Subject to: } \begin{cases} 0 \leq \{ R_{d1}, R_{d2}, \dots, R_{dn} \} \leq 1 \\ \{ I_1, I_2, \dots, I_n \} \leq I_{MAX} \\ I_1 + I_2 + \dots + I_n = I_{load} \end{cases} \quad (11)$$

$$\text{Consider: } \begin{cases} I_1 : I_2 : \dots : I_n = \frac{1}{R_{d1}} : \frac{1}{R_{d2}} : \dots : \frac{1}{R_{dn}} \\ \eta_j(I_j) = 0.975 \cdot e^{-2 \times 10^{-3} \cdot I_j} - 0.1257 \cdot e^{-0.3 \cdot I_j} \end{cases} \quad (12)$$

where  $P_{cvr\_loss}$  is the total power conversion loss calculated by (6),  $R_d$  is the VR of each converter, as the optimization is actually find an optimal sharing ratio, the given range of  $R_d$  is first set to  $[0,1]$ ,  $I_{MAX}$  is the maximal conversion current limit of each converter, the sum of converter output current should be equal to total load current. The ratio of output current among converters is equal the ratio of reciprocal of their VR.

According to (9)-(12), consider a system with two droop-controlled buck converters with same efficiency curve (Fig. 3), under certain load resistance  $I_{load}$ , objective  $P_{cvr\_loss}$  can be plotted with respect to VRs ( $R_{d1}$ ,  $R_{d2}$ ), as shown in Fig. 6(a)-(c). The shape and color represent the system power loss. The objective is to operate the system in colder color and lower height point.

According to the figures, in low and medium load current condition as shown in Fig. 6, it is more efficient to differentiate the sharing efforts between two converters while in high load current condition as shown in Fig. 6, it is better to equally share the load current.

### D. Optimization Algorithm Selection and Tuning

For solving the optimization model formulated above, a proper algorithm should be implemented. The selection of algorithm is based on the analysis of objective function. Global and local optimization methods are taken into option. The fastest optimization algorithms only seek local optimum point which is called local optimization, such as simplex method and gradient based algorithms. However, local optimization does not guarantee global optimal solution. On the other hand, global optimization algorithms, such as genetic algorithm (GA) and Particle Swarm Optimization (PSO), are able to find global optimum. However, they may require more computational time and space. Consequently, preliminary tests are necessary for improving algorithm efficiency.

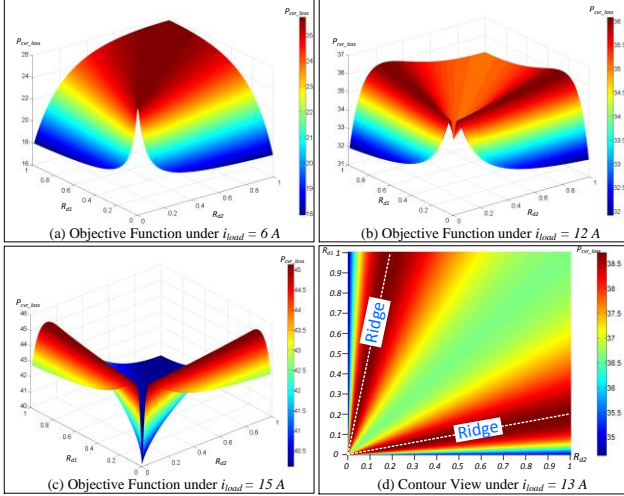

Figure 6. System Loss with Regard to Virtual Resistances

In Fig. 6(d), the white dashed lines show the ridge between two minimum sides. Different solutions are obtained with different initial points. Local optimization is not capable of climbing over the 'ridge'. Consequently, global optimization methods are preferred in this problem. In this paper, genetic algorithm is programmed and used to solve the optimization problem.

The basic parameters of GA significantly influence the performance of the program [11][12]. For different sorts of problems, good parameter settings of GA can be significantly different. When selecting parameters, such as population size ( $N_{pop}$ ) and maximum number of generations ( $N_g$ ), there is usually a tradeoff between computational time and quality of final solutions. In addition, as these parameters cannot be treated separately, a rational matching is also important.

In this paper, crossover rate is set to 0.8 (default setting),  $N_{pop}$  and  $N_g$  are tuned to achieve better performance. Case  $I_{load}=12A$  is used to adjust parameters because of the representativeness under this load condition, the algorithm is conducted 100 times to gather the final solutions (see Fig. 7). In order to use the least computational time while ensuring acceptable quality of final solutions, the tuning process starts from  $N_{pop} = 10$ ,  $N_g = 10$  (see Fig. 7(a)). With this setting algorithm is not able to always put solutions into near-optimum region. To improve the performance, both  $N_{pop}$  and  $N_g$  are increased gradually (see Fig. 7(a)-(d)). Final settings ( $N_{pop} = 30$ ,  $N_g = 200$ ) are able to enforce the objective function to converge to a near-optimum region.

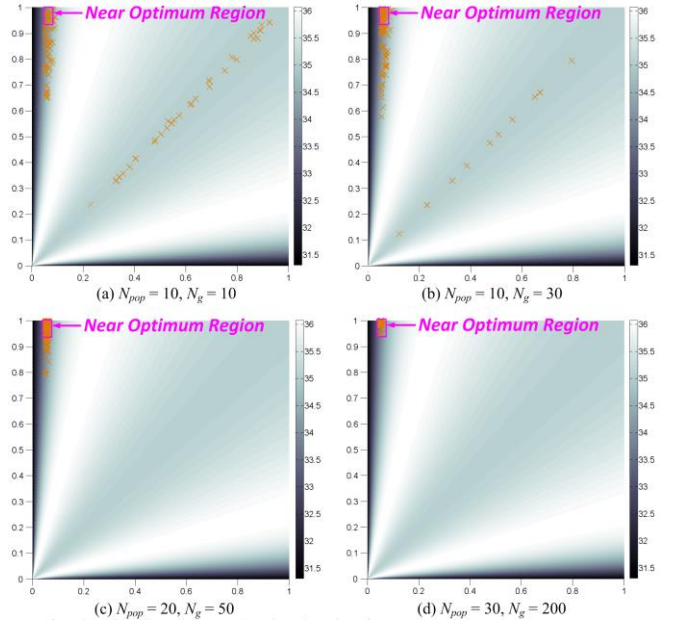

Figure 7. GA Parameter Tuning

#### IV. SYSTEM DYNAMIC CONSTRAINING – A SECONDARY CONTROL APPROACH

The dynamic model of a paralleled buck converter system (2 modules) is shown in Fig. 8. Voltage and current loops can be accomplished by conventional PI controllers together with output LC filter. VR appears as a proportional current feedback ( $R_{d1}$  and  $R_{d2}$ ) over inner control loops.

Based on Fig. 8, each converter can be described by the following dynamic model:

$$\begin{cases} \frac{1}{I_v} \cdot \dot{x}_V = -R_d \cdot i_L - (P_{sc} + 1) \cdot v_{DC} + x_{SC} + (P_{sc} + 1) \cdot v_{ref} \\ \frac{1}{I_c} \cdot \dot{x}_C = x_V - (R_d P_v + 1) \cdot i_L - P_v (P_{sc} + 1) \cdot v_{DC} + P_v \cdot x_{SC} \\ \quad + P_v (P_{sc} + 1) \cdot v_{ref} \\ L \cdot \dot{i}_L = P_c V_{in} \cdot x_V + V_{in} \cdot x_C - (P_c V_{in} (R_d P_v + 1) + R_p) \cdot i_L \\ \quad - (P_c P_v V_{in} (P_{sc} + 1) + 1) \cdot v_{DC} + P_c P_v V_{in} \cdot x_{SC} \\ \quad + P_c P_v V_{in} (P_{sc} + 1) \cdot v_{ref} \\ C \cdot \dot{v}_{DC} = i_L - \frac{1}{R_{load}} \cdot v_{DC} \\ \frac{1}{I_{sc}} \cdot \dot{x}_{SC} = -v_{DC} + v_{ref} \end{cases} \quad (11)$$

where  $x_V$ ,  $x_C$ ,  $i_L$ ,  $v_{DC}$  and  $x_{SC}$  are the outputs of voltage and current loop integrators, converter inductor current, capacitor voltage secondary control integrater respectively.  $P_v$ ,  $P_c$ ,  $P_{sc}$ ,  $I_v$ ,  $I_c$  and  $I_{sc}$  are the control parameters of voltage and current loop and voltage secondary control PI controllers,  $L$  and  $C$

are inductance and capacitance of the converter output filter,  $R_p$  is the parasitic resistance of inductance coils,  $R_{load}$  is the equivalent resistance of the connected load,  $V_{in}$  is the source voltage and  $v_{ref}$  is the reference voltage for secondary voltage control.

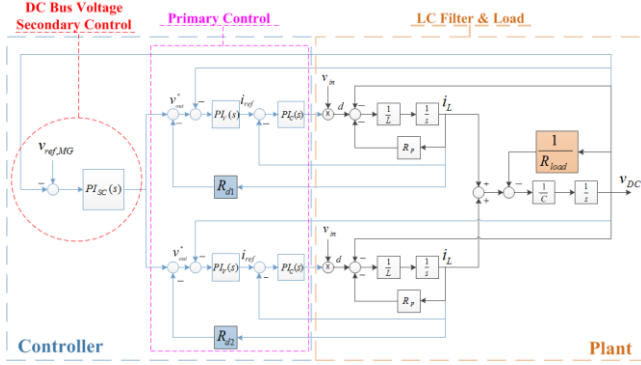

Figure 8. Dynamic Model of a System with Two Paralleled Converters

In order to analyze a general multi-module system consisting of  $N$  converters,  $N$  equations for Eq. (11) are embedded into the complete state space model:

$$\dot{x}_s = A_s \cdot x_s + B_s \cdot u \quad (12)$$

and all the modules share the common part of secondary control and capacitor.

### A. Root Locus Analysis

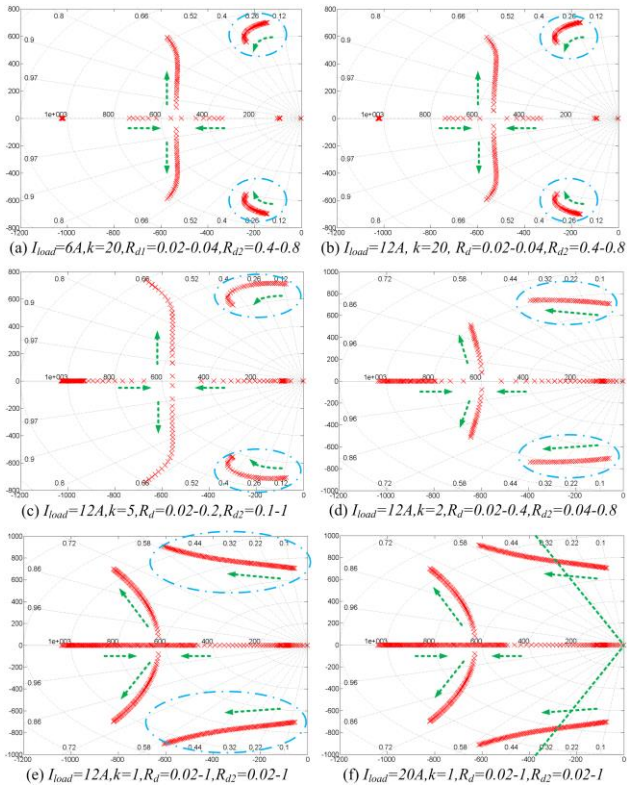

Figure 9. Dynamic Model of a System with Two Paralleled Converters

Based on the system state space model, root locus can be obtained and used to examine the system dynamics. Root locus for a 2-converter system is shown in Fig. 9. By change the VRs with different ratios ( $k=1, k=2, k=5, k=20$ ) in different load current levels, one can observe the shifting trends of the system dynamics. According to efficiency curve in Fig. 3, when load current is smaller than 8-10A, it is more efficient to use only single converter, when load is in medium level, an optimal ratio can be found, while at high load level, equally sharing load current is the most efficient way. Consequently, in Fig. 9, the root locus is obtained in different load levels, in low load level (6A), the ratio is set to 20:1, in medium load level (12A), sharing ratio is changed from 20:1 to 1:1 to see the system dynamic changing while in high load level (20A), the sharing ratio is set to 1:1.

First of all, in Fig. 9(a)-(f), with all the eigenvalues located in the left-half plane (negative real part), the system is stable. However, the damping and dynamics of the system should be constrained to a desired level. The minimum angle among all the eigenvalues actually represents the damping level of the system. Accordingly, in order to ensure that system operates with acceptable dynamic properties, the minimum angle of the eigenvalues should be controlled.

Fig. 9(a) shows the root locus under load current 6A, and the sharing ratio between two converters is 20:1 which means one converter generate the most load current needed, VR of one converter is shifting from 0.02-0.04, and VR of the other converter is shifting from 0.4-0.8 to keep the sharing ratio. The roots marked by dashed circle which have the minimum angle among all the roots are the ones affect most the system damping. Similar conclusion can be obtained according to Fig. 9(b)-(f). Consequently, it is reasonable to constrain the minimum angle of the eigenvalues by changing VRs of the converters with fixed ratio as shown in Fig. 9(f) (dashed line), while this ratio is actually the optimal sharing ratio given by optimization algorithm.

### B. Simulation Demonstration

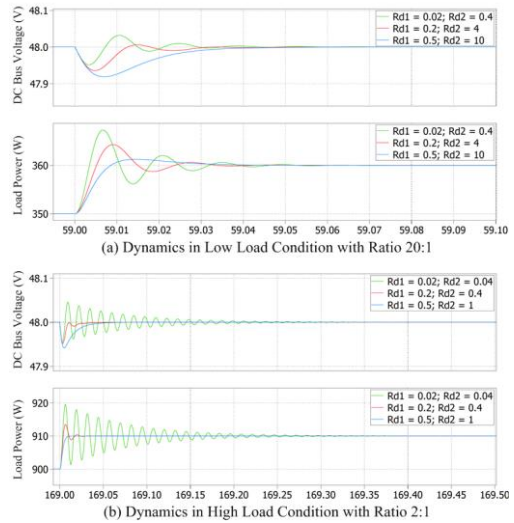

Figure 10. System Dynamics Comparison With Different VR ratio

To demonstrate the conclusion drawn above, the simulation results are shown in Fig. 10. Fig. 10(a) shows the dynamic comparison in low load condition when VRs have the same ratio (20:1) but with different values which demonstrates that by shifting the VRs under a fixed ratio, it is possible to find a desired damping, and the angle of the eigenvalues can be used for adjusting the damping level. Fig. 10(b) is the result in high load levels with different VR ratios which gives the same conclusion.

### C. Secondary Control for System Damping Restoration

Based on the conclusion above, SDSR is proposed, as shown in Fig. 11.

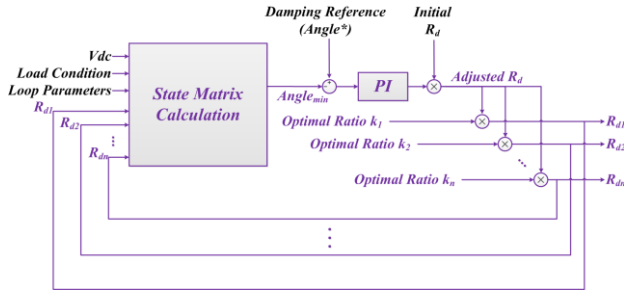

Figure 11. System Damping Secondary Restoration

The State Matrix Calculation block calculates the minimum angle of eigenvalues according to system information (dc bus voltage, load condition, etc.) and system state space model. The minimum angle,  $Angle_{min}$ , is compared with a damping reference which is an angle value, the error is sent to a PI controller to adjust an Initial  $R_d$  value. Finally, this value is multiplied by the optimal ratios which are generated by optimization algorithm.

Usually, before the final VRs are sent to converter, low pass filters are necessarily needed to smooth the shifting process. The parameters of the PI controller and the low pass filter are given in Section V.

## V. SIMULATION RESULTS

In order to validate the method presented in the paper, simulation is conducted with four droop controlled dc-dc paralleling converters. The parameters of each control loop and plant are shown in TABLE I. The conversion system consists of four 100/48V buck converters with maximum output current 20A each. Conventionally, all the VRs are set to 0.24 Ohm so as to equally share load current.  $L$  and  $C$  are output filter inductor and capacitor,  $P_v$ ,  $P_c$ ,  $P_{sc}$ ,  $P_{dp}$ ,  $I_v$ ,  $I_c$ ,  $I_{sc}$  and  $I_{dp}$  are the proportional and integral term of voltage inner loop, current inner loop, voltage secondary control loop and SDSR loop,  $Damping (Angle^*)$  is set to 1.9 rad, this value can be adjusted according to different system damping requirements. The cut-off frequency of VR shifting control is set to 5 Hz. And the four converters have small efficiency differences, set converter 1 has the highest efficiency while converter 4 has the lowest. All the simulations are conducted with comparison among three kinds of control method: (1) conventional fixed droop, (2) optimized sharing ratio without SDSR, (3) optimized sharing ratio with SDSR.

TABLE I. SIMULAITON SYSTEM PARAMETERS

Class	Parameters	
	Name	Value
Converter System Basic Setting	Converter Type	100V/48V Buck
	Max. Current of Each	20 A (1000 VA)
	Conventional Droop ( $R_d$ )	0.24 Ohm
Plant	$L$	1.8e-3 H
	$C$	2.2e-3 F
Inner Loop	$P_c$	1
	$I_c$	97
	$P_v$	0.5
	$I_v$	993
Voltage Secondary	$P_{sc}$	0.02
	$I_{sc}$	70
Damping Secondary	$P_{dp}$	0.01
	$I_{dp}$	20
	$Damping*(Angle^*)$	1.9 rad
LPF	Cut-Off Frequency	5 Hz
Efficiency	$Eff_{con1} > Eff_{con2} > Eff_{con3} > Eff_{con4}$	

### A. Load Current increasing

First, a simulation is conducted with gradually increasing load power as shown in Fig. 12. According to the system power loss and system efficiency comparison, the optimized control, either with or without SDSR, has obvious improvement in low and medium load level while in high load level, the room for optimization is limited. This result is in accordance with objective function analysis in Section III. Furthermore, during the load increasing, the DC Bus Voltage is always stabilized to rated value 48V. The current wave forms show the tactic of employing converters in different load levels. Since converter 1 has the highest efficiency, it is employed most, while converter 4 has the lowest efficiency, it is the last considered converter.

Although in Fig. 12, the control methods with and without SDSR have the same efficiency improvement, their system dynamics are different, as shown in Fig. 13. System dynamic are compared in low and high load level conditions with the three control methods. In both load condition, the ones with SDSR have obvious system dynamic improvement compared with the ones with conventional fixed droop or without SDSR.

Finally, some random load profile is input to simulation system to test the system optimization performance and response, as shown in Fig. 14. As expected, the system efficiency improvements in low and medium load levels (Phase 1 and Phase 2) are more impressive. And this simulation also demonstrates the effectiveness of the method.



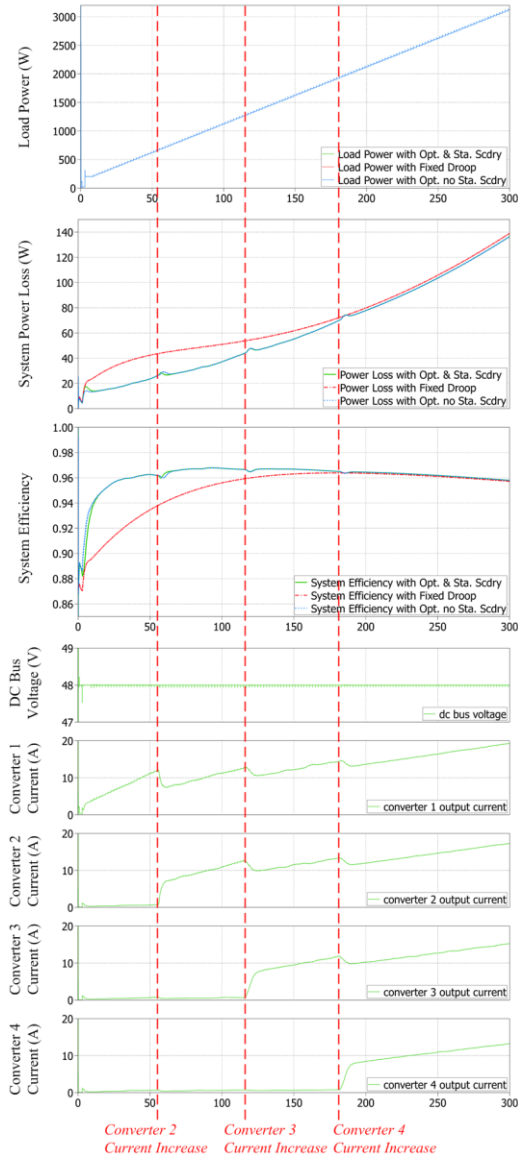

Figure 12. Simulation Results with Increasing Load Power

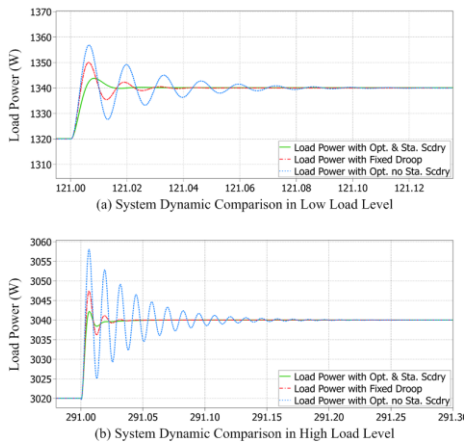

Figure 13. System Dynamic Comparison

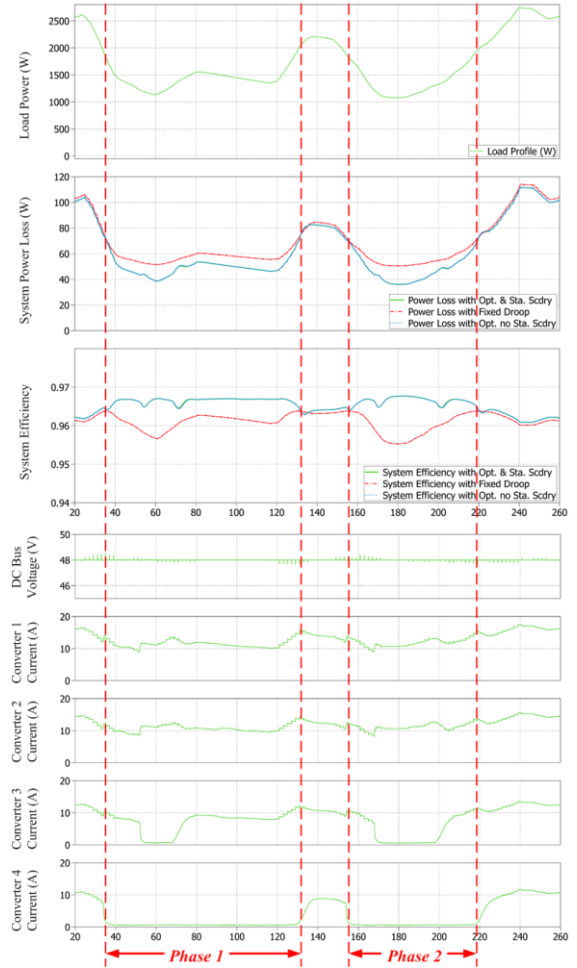

Figure 14. Simulation Results with Random Load Profile

## VI. CONCLUSION

In this paper, an optimization method is proposed for improving operation efficiency of paralleled dc-dc converter system. Conventionally, load current is equally shared among converters that the system efficiency is low especially in low and medium load conditions. This paper proposes a VR shifting method to adjust sharing proportion among converters. Hierarchical control conception is adopted so that droop method is employed on top of primary control level, voltage secondary control takes charge of voltage deviation restoration while smoothing higher level regulation, GA is implemented in tertiary level for searching optimal sharing ratio so as to improve system efficiency. In order to ensure system stability as well as restore system damping to a desired level after optimization, a system damping secondary restoration control is proposed. The state space matrix of the paralleling system is used for the system dynamic analysis. As the minimum angle of eigenvalues of the state matrix represents system damping, it is used as control variable in system damping secondary restoration.

Simulations are conducted in a system with four buck converters which have different efficiency. The results

indicate the potential of efficiency improvement for parallel converter system. Also the method proposed is demonstrated to be capable of improving system efficiency while keeping desired system damping.

#### REFERENCES

- [1] Wu Chen; Xinbo Ruan; Hong Yan; Tse, C.K., "DC/DC Conversion Systems Consisting of Multiple Converter Modules: Stability, Control, and Experimental Verifications," *Power Electronics, IEEE Transactions on*, vol.24, no.6, pp.1463,1474, June 2009
- [2] Anand, S.; Fernandes, B. G., "Modified droop controller for paralleling of dc-dc converters in standalone dc system," *Power Electronics, IET*, vol.5, no.6, pp.782,789, July 2012
- [3] Salomonsson, D.; Sannino, A., "Low-Voltage DC Distribution System for Commercial Power Systems With Sensitive Electronic Loads," *Power Delivery, IEEE Transactions on*, vol.22, no.3, pp.1620,1627, July 2007
- [4] Karlsson, P.; Svensson, J., "DC bus voltage control for a distributed power system," *Power Electronics, IEEE Transactions on*, vol.18, no.6, pp.1405,1412, Nov. 2003
- [5] Guerrero, J.M.; Vasquez, J.C.; Matas, J.; de Vicuña, L.G.; Castilla, M., "Hierarchical Control of Droop-Controlled AC and DC Microgrids—A General Approach Toward Standardization," *Industrial Electronics, IEEE Transactions on*, vol.58, no.1, pp.158,172, Jan. 2011
- [6] Xiaoxiao Yu; Khambadkone, A.M.; Huanhuan Wang; Terence, S.; , "Control of Parallel-Connected Power Converters for Low-Voltage Microgrid—Part I: A Hybrid Control Architecture," *Power Electronics, IEEE Transactions on*, vol.25, no.12, pp.2962-2970, Dec. 2010
- [7] Barklund, E.; Pogaku, N.; Prodanovic, M.; Hernandez-Aramburo, C.; Green, T.C., "Energy Management System with Stability Constraints for Stand-alone Autonomous Microgrid," *System of Systems Engineering, 2007. SoSE '07. IEEE International Conference on*, vol., no., pp.1,6, 16-18 April 2007
- [8] Bidram, A.; Davoudi, A., "Hierarchical Structure of Microgrids Control System," *Smart Grid, IEEE Transactions on*, vol.3, no.4, pp.1963,1976, Dec. 2012
- [9] Klimczak, P.; Munk-Nielsen, S., "Comparative study on paralleled vs. scaled dc-dc converters in high voltage gain applications," *Power Electronics and Motion Control Conference, 2008. EPE-PEMC 2008. 13th*, vol., no., pp.108,113, 1-3 Sept. 2008
- [10] Weimin Wu; Xiaoli Wang; Pan Geng; Tianhao Tang, "Efficiency analysis for three phase grid-tied PV inverter," *Industrial Technology, 2008. ICIT 2008. IEEE International Conference on*, vol., no., pp.1,5, 21-24 April 2008
- [11] Grefenstette, J.J., "Optimization of Control Parameters for Genetic Algorithms," *Systems, Man and Cybernetics, IEEE Transactions on*, vol.16, no.1, pp.122,128, Jan.
- [12] Yussof, S.; Ong Hang See, "The effect of GA parameters on the performance of GA-based QoS routing algorithm," *Information Technology, 2008. ITSIM 2008. International Symposium on*, vol.4, no., pp.1,7, 26-28 Aug. 2008