

# LIFETIME INVESTIGATIONS OF A LITHIUM IRON PHOSPHATE (LFP) BATTERY SYSTEM CONNECTED TO A WIND TURBINE FOR FORECAST IMPROVEMENT AND OUTPUT POWER GRADIENT REDUCTION

**Maciej Świerczyński**  
Aalborg University  
Aalborg, Denmark

**Remus Teodorescu**  
Aalborg University  
Aalborg, Denmark

**Pedro Rodriguez**  
UPC Barcelona  
Barcelona, Spain

## INTRODUCTION

Through the years of development, network stability was only based on so-called conventional generation units. In recent times, when mankind is looking for more environmentally friendly and renewable solutions, energy produced by wind turbines seems to be the most promising of renewables, mainly due to the abundance of the wind resource. But, beyond its many advantages, wind energy brings new challenges for the stable operation of the power system. Wind turbines are producing energy only when the wind is blowing, and its power level varies significantly (to the third power), depending on the wind strength. Wind turbines' intermittent, partly unpredictable power production introduces variable power to the grid. That changeability has to be compensated by other (usually fossil based) conventional generation units in order to assure grid stability. However, the higher the percentage of installed wind capacity, the higher the problem of wind integration into the power system and the need for more conventional units that can handle the variable power production of wind turbines.

Energy storage addition to wind turbines is one of the most promising solutions to problems related to integration of wind power into the energy network. Not only can it decrease the wind turbine's variability, but it can also decouple moments of energy production and generation.

Lithium Ion batteries and especially Lithium Iron Phosphate (LFP) batteries can be characterized by high power densities, relatively long life-time, no maintenance and a lot of research currently being done on increasing their performance. Therefore, they seem to be a good choice for integration with wind turbines. However, the current Lithium Ion energy storage price and its limited lifetime are the main obstacles to the integration of storage technologies with wind turbines. That is why proper lifetime estimation of the lithium ion batteries, working with mission-profile characteristics for specific services, is very important, not only for optimisation of the revenues but also for correct scheduling of the maintenance jobs. This paper analyzes the connection of LFP battery storage systems into wind turbines, with a high focus on the lifetime of LFP batteries for selected services.

## SYSTEM UNDER STUDY

The system that is being studied is shown in Figure 1. A 2 MW wind turbine with a full back to back converter is connected to the grid through the Point of Common Coupling (PCC). To the same point, an LFP battery energy storage system is connected through a converter, a filter and a transformer. Moreover, a Battery Management System (BMS) collects the information on current wind turbine power production. The BMS also gets information regarding service that is supposed to be delivered, forecast data, and actual values of the battery voltage and current. The BMS processes this information to obtain a power reference signal to the battery controller. The battery controller calculates required battery output current based on actual battery voltage and SOC values. The battery controller is able to limit or stop battery output power depending on actual battery operating conditions.

In order to predict battery behavior under different operational conditions, a model of an LFP battery was developed. The Lithium ion battery is modeled as an SOC controlled voltage source and equivalent impedance. Values of the equivalent impedance are also a function of SOC. To each value of the equivalent circuit, specific physical phenomena can be ascribed. In Figure 2, a block diagram of the simulated LFP battery is shown.

Model parameters are obtained by performing frequency analyses with Electrochemical Impedance Spectroscopy (EIS) for different values of SOC. Small signal impedance analysis results for different values of SOC of a 50Ah LiFePO<sub>4</sub> battery cell are shown in Figure 3. Tests were performed in laboratory conditions under a controlled temperature with the battery test station (Figure 4).

Furthermore, the model takes into account physical limitations of the battery, such as maximum charging/discharging C-rate (power limitation), maximum Depth of Discharge (DOD), and a rainflow counting algorithm, which will be described further in this paper. The LFP battery model was validated later by comparing real battery cell charging and discharging characteristics with charging and discharging characteristics produced by the model.

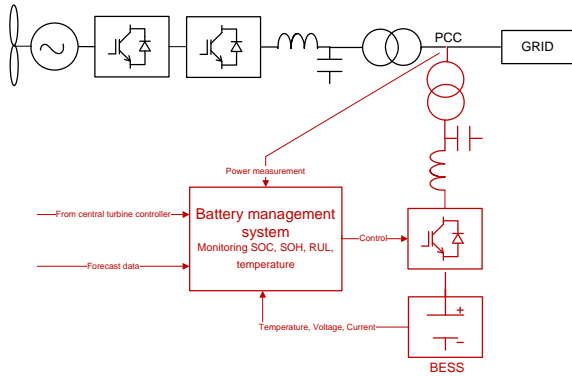

Figure 1 System under study

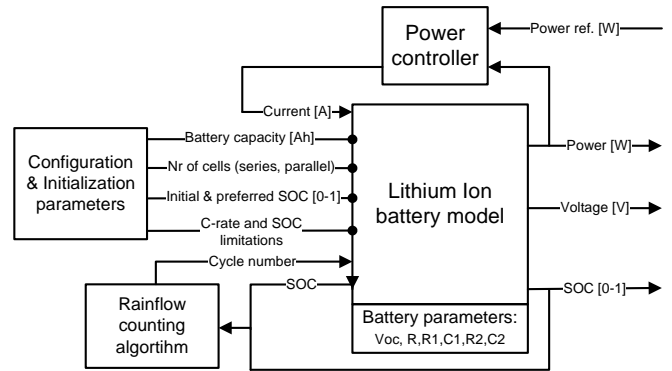

Figure 2 Block diagram of the battery model

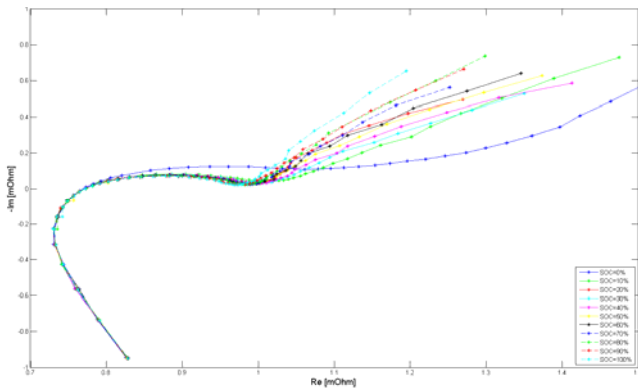

Figure 3 Measured Nyquist plots of 50Ah battery cell for different values of SOC

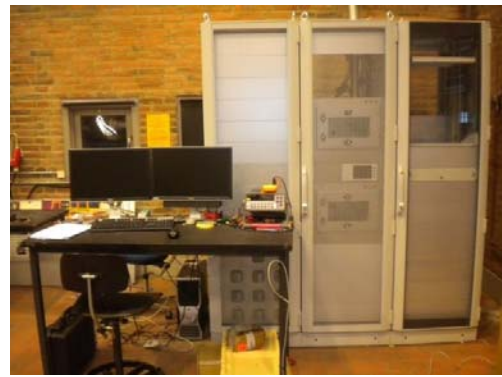

Figure 4 Battery test station used for model parameterization

## APPLICATIONS OF INTEREST

Amongst plenty of possible services that the battery can provide, two of them are of interest for this paper: wind turbine power production forecast improvement and wind turbine output power gradient reduction. Features of both services are juxtaposed in **Error! Reference source not found.** Both services are interesting because they allow higher wind penetration in the grid; they do not require huge storage size and can be combined together in one controller.

### Wind turbine power production forecast improvement

Because of the limited wind forecast certainty and the fact that power production of the wind turbine is proportional to the third power of wind speed, a small error in wind speed forecast can have significant influence on power production forecast. Production predictability from a wind turbine depends on the quality of the weather forecast and of the service forecast. Forecast accuracy is dependent on time scale, site and season. In some markets, for instance, Spain, there are penalties imposed on wind energy suppliers when generation does not match the amount of generation bid for delivery.

To some extent, it is possible to decrease forecast error with Lithium Ion batteries by compensating for unforeseen changes in the wind. Differences between forecasted and actual power generation can introduce problems with power system stability, especially in the case of high wind power penetrations in the grid. Differences between contracted and delivered power by wind turbine can be significantly decreased with energy storage, thus bringing the behaviour of a wind turbine closer to that of a conventional generation unit.

**Wind turbine output power gradient reduction**

Quick and unforeseen variations of the wind turbine output power are not desirable because there is a need to compensate for them with fast reacting conventional generation units. Lithium ion batteries added to wind turbines are able to keep the power gradient (dP/dt) within required limits or, in other words, it is possible to control the steepness of power changes, giving some time to other generation units to compensate for wind fluctuations. As a consequence, network stability can be improved and costs of the spinning reserve can be decreased.

**Table 1 Characteristics of selected applications**

	<b>Wind turbine output power gradient reduction</b>	<b>Wind turbine power production forecast improvement</b>
<b>Definition:</b>	Reduction of wind turbines rate of power change in a certain timescale.	Reduction of error between actual and forecasted production.
<b>Why is it important?</b>	Grid stability support. No need for fast reacting generators which have to compensate for fast power changes.	Grid stability support and better forecasting allows better generation scheduling. No penalties.
<b>Comments:</b>	The stability problem arises due to fast changes in power output from wind power generation, which the remaining fully controllable generation in the grid must be able to counteract.	Addition of ES cannot only improve the forecast but, in some markets, help avoid penalties.
<b>Reaction time</b>	~1s	~1min
<b>WPP without Energy Storage:</b>	<b>(limited only to upward by pitching)</b>	<b>(only if forecasted power is lower than produced)</b>
<b>WPP with Energy Storage:</b>	✓	✓

**RAINFLOW CYCLE COUNTING METHOD**

In this paper, lifetime estimations of LFP batteries are based on the rainflow cycle counting method, which was first introduced in the field of mechanical engineering (Ref.1) and was originally intended to count fatigue cycles in materials in order to predict stress levels and possible failure. The algorithm is not only able to count the number of cycles, but also separates them according to their magnitude. This method has been used before to predict the lifetime of batteries (Ref. 2). There are two assumptions behind this method: (a) order of loading makes no difference, and (b) damage accumulation is independent of the stress level.

End of life for batteries is usually defined as a drop of battery capacity by 20% in comparison to the initial, fully-rated capacity of the battery cell. According to this method, failure occurs when the following formula is satisfied:

$$\sum_{DOD=1}^{DOD=100} \frac{N_{DODx}}{N_{max}} = 1$$

Where:

$N_{max}$  - maximum number of 100% Depth of Discharge (DOD) cycles the battery can handle before the end of life occurs.

$N_{DODx}$  - number of cycles from DOD=x

$\sigma_x$  - maximum number of cycles the battery can handle before the end of life occurs for DOD=x

$x = \langle 0\%; 100\% \rangle$

Battery manufacturers usually provide the relationship between battery cycle life and battery DOD. Figure 5 shows the relationship between the maximum number of cycles the battery can handle before end of life occurs and different values of DOD. For the LFP battery considered in this paper, the relationship is shown in Figure 6. The characteristic is strongly nonlinear, and the battery has a much longer life cycle in the case of low DOD cycles.

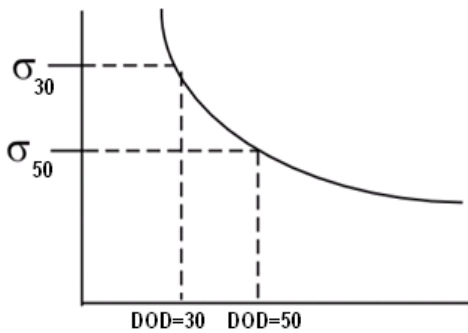

**Figure 5 Illustration of the maximum number of cycles the battery can handle before end of life occurs as a function of DOD.**

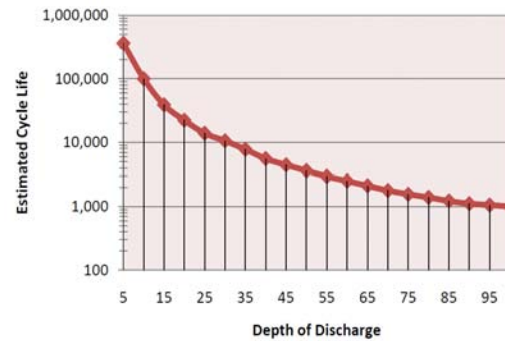

**Figure 6 Relationship of battery cycle life as a function of DOD for the considered LFP battery.**

The method of rainflow cycle counting is useful for determining battery end of life when the battery is subjected to complex cycles, such as in the considered applications of wind turbine power production forecast improvement and wind turbine output power gradient reduction. The algorithm is able to reference complex cycles to an equivalent number of 100% DOD cycles.

### BATTERY STORAGE SIZE VERSUS PERFORMANCE FOR SELECTED SERVICES

Both services were simulated for a period of one year, and real 2 MW wind turbine production data was used. In Figure 7, simulated LFP battery mission profiles for wind turbine power production forecast improvement and wind turbine power gradient reduction are shown. It can be seen that gradient reduction requires peaks of power and a small amount of energy, while forecast improvement requires both power and energy capability from the battery storage system.

#### Wind turbine power production forecast improvement

In the following simulation studies, wind power forecast data was not available, and it was emulated with the algorithm described in (Ref. 3) (Figure 8). Furthermore, the wind turbine is assumed to participate in a day ahead market. The forecast is being generated 36 hours ahead for each day, based on statistical methods. The deterministic component of the forecast error taken for simulation studies is 10%, while the stochastic component is 5%.

The accuracy of the forecast data is often determined by Normalized Mean Average Error (NMAE), which can be calculated according to the following formula:

$$NMAE = \frac{\frac{1}{N} \cdot \sum_{t=1}^N |P_F(t) - P_W(t)|}{P_{WT}}$$

Where:

$P_F(t)$  - forecasted power [W]

$P_W(t)$  - power production of the wind turbine [W]

$P_{WT}$  - Nominal wind turbine power [W]

N – total number of data periods (in considered case 365 days)

In the case of wind turbine power production forecast improvement, the LFP battery system is used to reduce the NMAE of the forecast. The success criterion of such system is a confidence level of 95%.

An added energy storage system is lowering the NMAE throughout the forecast period. Figure 10 presents how the addition of a different size of LFP battery storage system influences forecast error. Storage power is related to wind turbine nominal power, and storage size is considered to be 1 hour. It can be observed that storage of 25 % of wind turbine nominal power is able to decrease the NMAE coefficient almost by a factor of 2. However, a further increase in storage power has only a small influence on forecast error.

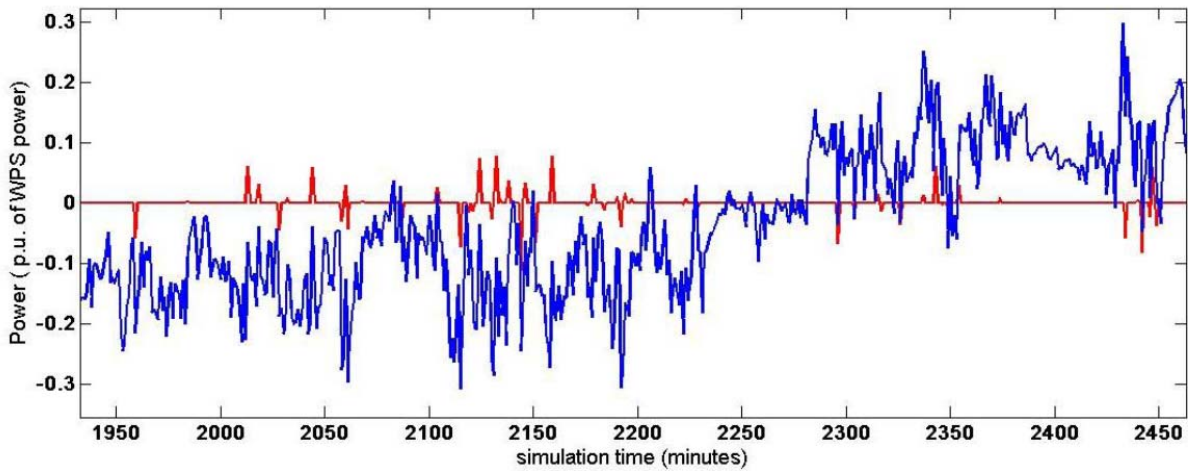

Figure 7 Hypothetical Lithium ion battery mission profiles for two different services: (red color) – WT output power gradient reduction, (blue color) – forecast improvement

### Wind turbine output power gradient reduction

For wind turbine output power gradient reduction, the LFP battery storage system controller examines wind turbine power production at PCC and makes sure that the rate of power change does not exceed the maximum determined gradient value. In Figure 9, an example of limiting the power gradient to 5% of wind turbine nominal power per minute is shown.

In order to be able to assess the performance of power gradient reduction, a Mission Profile Fulfillment (MPF) coefficient is proposed and defined as follows:

$$MPF = \frac{\text{Total energy delivered|absorbed by LFP storage}}{\text{Total energy that is required according to Mission Profile}} \cdot 100\%$$

The MPF coefficient change with a function of LFP battery storage power size is shown in Figure 11. A simulation for 30 minutes storage time is performed. One can see that, in order to achieve maximum wind turbine output power gradient not higher than 10% of wind turbine nominal power per minute with an MPF=90% in a one year period, it is necessary to have a storage size of 5% of the wind turbine power for 30 minutes. To obtain the same MPF in the case of a 1% gradient per minute, storage power of 40% of wind turbine power for 30 minutes is required.

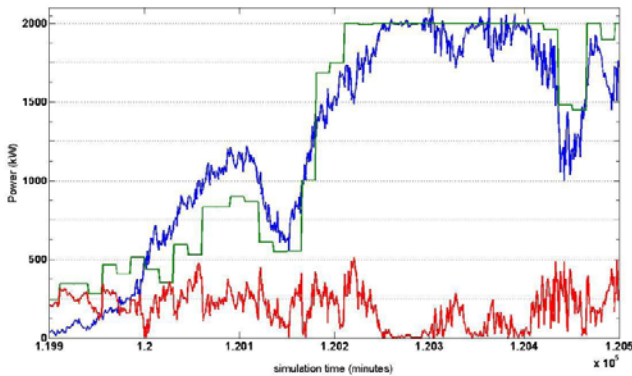

**Figure 8 Illustration of wind power production forecast error. (Green color – wind power production forecast – 15min resolution, Blue color –wind turbine production, Red color – forecast error)**

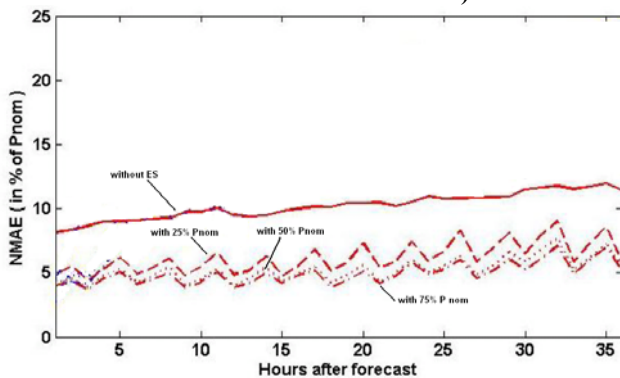

**Figure 10 NMAE for different cases: a) without storage (statistical forecasting method), b) with 25% of Pnom, c) with 50% of Pnom, d) with 75% of Pnom. Storage time: 60 minutes**

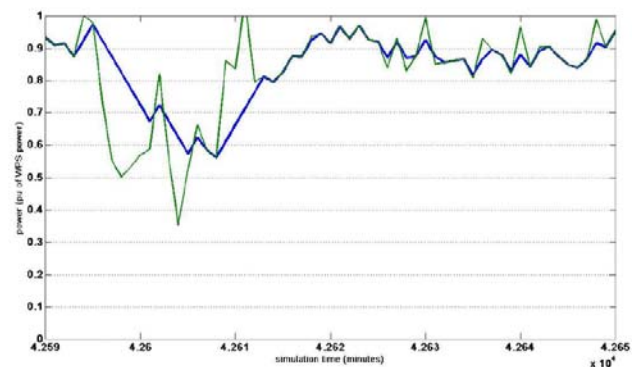

**Figure 9 Illustration of wind turbine output power reduction to 5% of nominal power per minute. (Green color – without Energy Storage, Blue color – with connected Lithium ion batteries)**

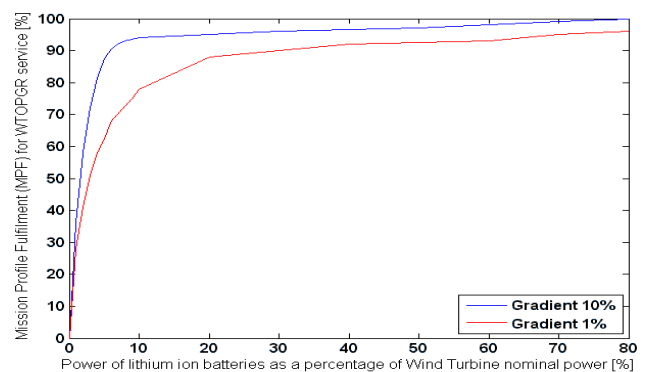

**Figure 11 Mission Profile Fulfillment (MPF) in function of Lithium ion power output for WTOPGR service. Storage time: 30 minutes**

## BATTERY LIFETIME INVESTIGATIONS FOR SELECTED SERVICES

In the following, the lifetime of LFP batteries for selected services will be presented. Lifetime is being calculated based on the rainflow counting algorithm described previously. The goal is to determine the lifetime of an LFP battery energy storage system as a function of the LFP battery size, and juxtapose obtained values with the performance coefficient for a given service.

In the forecast improvement service case, an LFP battery with a storage time of 120 minutes was arbitrarily chosen. Figure 12 presents simulation results for wind turbine power production forecast improvement service. It can be seen that, in order to decrease forecast error by a factor of 2 and assure energy storage lifetime equal to wind turbine lifetime (20 years), it is necessary to have an LFP battery energy storage system of 85% of wind turbine nominal power for 2 hours. In the case of a 2 MW wind turbine, the required LFP battery energy storage system is equal to 3.4MWh.

In Figure 13, similar considerations for wind turbine output power gradient reduction are shown. In the case shown, a stringent gradient of 1% of wind turbine nominal power per minute is required. Storage time is considered fixed and equals 30 minutes. One can see that, in order to obtain an LFP energy storage lifetime equal to 20 years, it is necessary to have storage of 40% of wind turbine nominal power for 30 minutes. For that case, the MPR coefficient is equal to 90%. In the considered case of a 2 MW wind turbine, the required LFP battery energy storage system is equal to 400kWh.

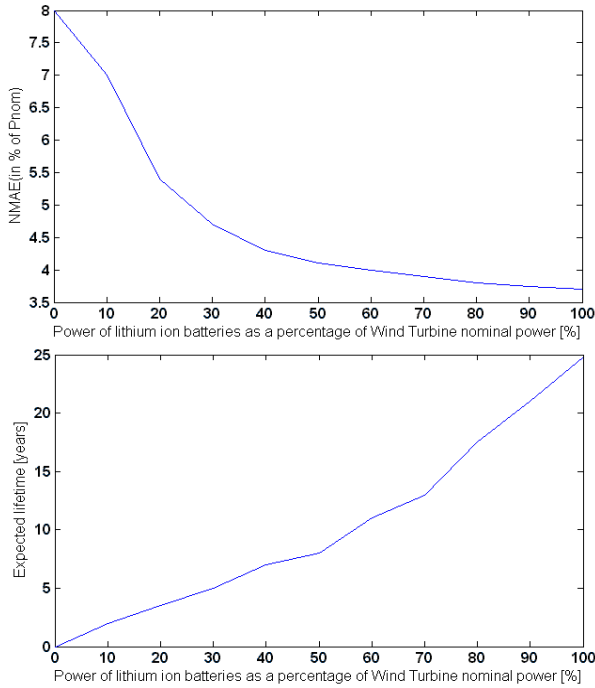

**Figure 12 Forecast improvement with Lithium ion batteries. Storage time 120 minutes. NMAE as a function of Lithium ion BESS power (upper graph) and expected BESS lifetime based on rainflow counting method (lower graph)**

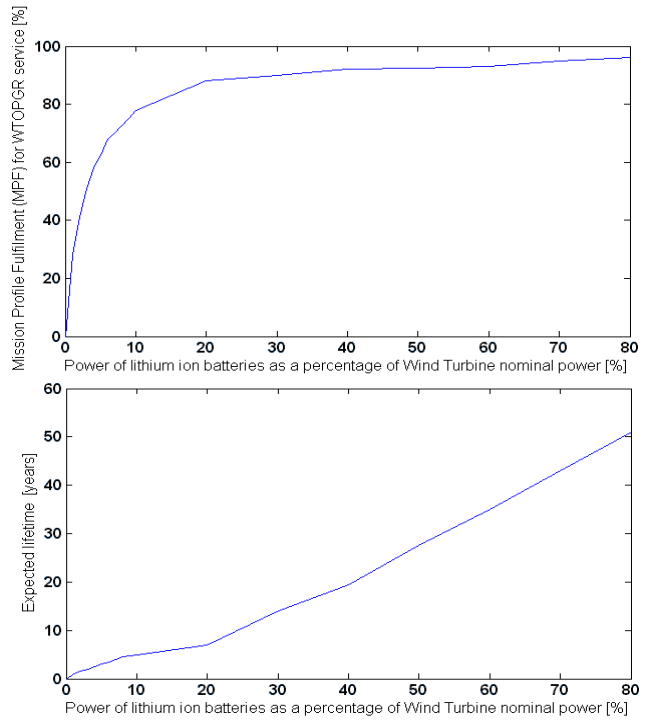

**Figure 13 wind turbine output power gradient reduction to 1% of P<sub>nom</sub> with Lithium ion batteries. Storage time 30 minutes. MPF as a function of Lithium ion BESS power (upper graph) and expected BESS lifetime based on rainflow counting method (lower graph)**

## CONCLUSION

High penetration of wind energy in the grid can be difficult to achieve without energy storage. Addition of energy storage to a wind turbine helps solve problems related to wind integration in the power system. In this paper, two applications of energy storage connected to a wind turbine are presented. Service performance coefficients as functions of storage size are shown. Moreover, battery lifetime as a function of battery size for selected services are studied. The addition of LFP batteries to wind turbines improves wind turbine power production predictability and enables compensation of fast and unforeseen wind turbine power production changes.

There are differences between the two selected services, both in power magnitudes and in total energy required from an LFP battery storage system. Gradient reduction service requires pulse shaped power from batteries, while forecast improvement requires both high power and a high amount of energy from energy storage.

In general, according to the rainflow counting method, doubling LFP battery storage system size leads to more than double the battery lifetime. The LFP battery storage system lifetime is influenced by storage size and the level of required performance coefficient for the given service. It is also worth mentioning that the studied LiFePO<sub>4</sub> battery does not represent the best case, and LFP batteries with higher lifetime can already be found on the market.

## REFERENCES

1. Sørensen, P., Hansen, A. D., Rosas, P. A. C., “*Wind models for simulation of power fluctuations from wind farms.*” *Journal of Wind Engineering and Industrial Aerodynamics* 90 (2002) 1381-1402.
2. Kawakami, M., Iijima, Y., Sakanata, Y., Fukuhara, M., Ogawa, K., Bando, M., Matsuda, T., “*Development and field experiences of a stabilization system using 34 MW NAS batteries for a 51MW wind farm.*”
3. Zhaoyin, Wen, “*A study on the energy storage technology of the sodium sulfur battery and its application in power systems.*”