



Aalborg Universitet

AALBORG UNIVERSITY
DENMARK

Study of High Voltage AC Underground Cable Systems

da Silva, Filipe Miguel Faria; Bak, Claus Leth; Wiechowski, Wojciech T.

Published in:

Proceedings of the Danish PhD Seminar on Detailed Modelling and Validation of Electrical Components and Systems 2010

Publication date:

2010

Document Version

Publisher's PDF, also known as Version of record

[Link to publication from Aalborg University](#)

Citation for published version (APA):

da Silva, F. M. F., Bak, C. L., & Wiechowski, W. T. (2010). Study of High Voltage AC Underground Cable Systems. In *Proceedings of the Danish PhD Seminar on Detailed Modelling and Validation of Electrical Components and Systems 2010* (pp. 10-15). Energinet.dk.

General rights

Copyright and moral rights for the publications made accessible in the public portal are retained by the authors and/or other copyright owners and it is a condition of accessing publications that users recognise and abide by the legal requirements associated with these rights.

- Users may download and print one copy of any publication from the public portal for the purpose of private study or research.
- You may not further distribute the material or use it for any profit-making activity or commercial gain
- You may freely distribute the URL identifying the publication in the public portal -

Take down policy

If you believe that this document breaches copyright please contact us at vbn@aub.aau.dk providing details, and we will remove access to the work immediately and investigate your claim.

Study of High Voltage AC Underground Cable Systems

F. Faria da Silva, Claus L. Bak, Wojciech T. Wiechowski

ABSTRACT

High-Voltage cables are starting to be more often used to transmit electric energy at high-voltage levels, introducing in the electric grid phenomena that are uncommon when using Overhead Lines. Under the phenomena worthy of special attention are those related with the cable energisation and deenergisation. Examples are switching overvoltage, zero-missing phenomenon, energisation of cables in parallel, series resonance and disconnection overvoltage, all described and explained in this paper.

This paper starts by describing the main objectives of this PhD project, followed by a description of the different phenomena, illustrated by simulations based on real cable/system parameters.

I. INTRODUCTION

On the 4th of November 2008, Denmark Government decided that in order to reduce the visual pollution caused by Overhead Lines (OHL), all the transmission lines with a voltage level equal and below 150 kV must be undergrounded gradually within the next 20 years. Additionally, all new 400 kV lines will be built as cable lines (with some exceptions) [1][2]. This massive use of HV cables will force to some changes in the philosophies used until now for the planning, analysis and operation of electrical power systems.

This PhD project intends to study the main problems affecting systems using a large number of HV cables and present the respective solutions. The PhD project should also provide guidelines to be used in the migration from an OHL based grid to a cable grid.

II. PROBLEM DEFINITION

Cables have electric characteristics distinct from OHL, being the most notable the higher capacitance of the first ones,

This work is supported by Energinet.dk.

F.F.S. is a PhD student at the Institute of Energy Technology, Aalborg University, 9220 Aalborg, Denmark (e-mail: fms@energinet.dk, phone no. +45 99 40 92 80).

C. L. B. is with the Institute of Energy Technology, Aalborg University, 9220 Aalborg, Denmark (e-mail: clb@iet.aau.dk).

W. T. W. is a Senior System Analyst at the Planning Department of Energinet.dk (e-mail: wwi@energinet.dk)

Paper submitted to the PhD Seminar on Detailed Modelling and Validation of Electrical Components and Systems 2010 in Fredericia, Denmark, February 8th, 2010

what results in a larger production of reactive power by the line and reduction of transmitted active power. Other consequences are an increase of power losses and a raise of the voltage in the receiving end.

To compensate the generated reactive power are usually installed shunt reactors, which due to their inductive characteristic raise other problems to the system, being the more notably ones resonances.

In the analysis of a cable system especial attention must be given to the transients, as the connection/disconnection of a cable is a complex electromagnetic phenomenon that may originate overvoltage in the energised cable, and strongly affect the rest of the grid.

Harmonics are also a relevant issue in cable systems. As cables have a large capacitance than OHL, the resonance frequencies will be at lower frequencies than in OHL based grids, and thus more likely to be a problem for the grid.

III. OBJECTIVES

The main objectives of this PhD project are:

- To identify the main problems on system with large amounts of HVAC cables;
- Study countermeasures for these problems;
- Do a full-scale test of a 100 km, 150 kV cable;
- Study of harmonic in a large HV cable system;
- Provide guidelines/suggestions for the planning of future electrical systems at 400kV, 150kV and 132kV levels;

IV. PHENOMENA DESCRIPTION

A. Energisation of a single cable

The energisation of a cable may origin a transitory overvoltage, which amplitude depends of the moment in which the cable is connected. If the circuit breaker is closed when the voltage at its terminals is zero the overvoltage is minimum, ideally zero, but if the connection is made for a peak voltage, the overvoltage is maximum.

The reason for this difference is the charging of the cable's capacitance and the energy oscillation between the cable's capacitance and inductance. To better understand this phenomenon it will be explained using a simple LC series circuit, as the one shown in Fig. 1, whose simulation's plot is shown in Fig. 2.

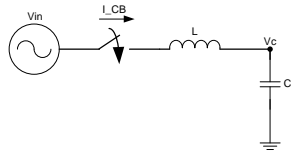

Fig. 1. LC Circuit

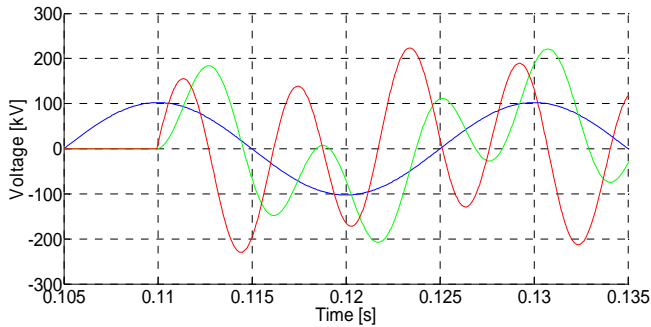

Fig. 2. Voltages and current (current not at scale) for Fig. 1 circuit when connected at peak voltage. (Blue: V_{in} , Green: V_c , Red: I_{CB})

In this system, initially both capacitor and inductor have no energy, but as the voltage in the capacitor (V_c) has to be continuous, when the circuit breaker closes for a voltage value that not zero, the capacitor has to be charged through the inductor, initiating a transient with the system natural frequency. After a very short moment the voltage in the capacitor is equal to the source voltage, but when this moment is reached the current in the inductor is at a peak value (see Fig. 2) and by energy conservation it can not become zero immediately. Thus the voltage in the capacitor continues to increase becoming larger than the source voltage while the current decreases to zero, when the current makes to zero V_c reaches a peak value and the capacitor starts to discharge [3].

As the system has no resistance this transient is not damped, and the oscillatory behaviour continues with one difference. Due to the fact that source is sinusoidal, for each transient cycle at system natural frequency, V_c will match the source voltage at different points, and thus the amplitude of V_c is different for each cycle, as the reference voltage for the capacitor terminals, is constantly changing.

Other phenomenon associated with cables' energisation is the appearance of a decaying DC current at the connection moment, what may lead to zero-missing phenomenon.

An easy way of understanding zero-missing phenomenon is by analysing an inductor in parallel with a capacitor of equal impedance. In this situation the currents in the capacitor and inductor have equal amplitude and are in phase opposition. The current in the inductor can also have a DC component, whose value depends on the voltage at moment of connection.

In an inductor there is a 90° phase difference between the current and the voltage at its terminals. Thus, if the voltage is zero the current should be maximum and vice-versa. The current in an inductor is continuous and zero before the connection, so it must also be zero after the connection regardless the voltage at moment of connection. Therefore, if

the inductor is connected for zero voltage, in order to maintain its continuity the current will have a DC component with amplitude equal to the amplitude of the AC component. If the inductor is connected for a peak voltage no DC component is present [4].

If there is no resistance in the system, the DC component is not damped and it will be maintained infinitely. In reality there is always some resistance and the DC component disappears after some time.

Fig. 3 shows an inductor in series with a resistor, both of them in parallel with a capacitor. The resistance is 100 times smaller than the inductor reactance, which is equal to the capacitor reactance. Fig. 4 shows a simulation of Fig. 3. The circuit breaker closes when the voltage is crossing zero, and therefore the DC component in the inductor is maximum. The inductive and capacitive AC components cancel out (I_L and I_C have equal amplitude and are in phase opposition) and the current I_I contains only the decaying DC component

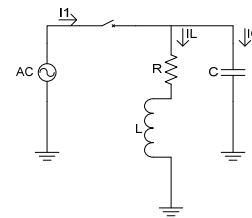

Fig. 3. Equivalent scheme of an inductor in series with a resistor, both in parallel with a capacitor

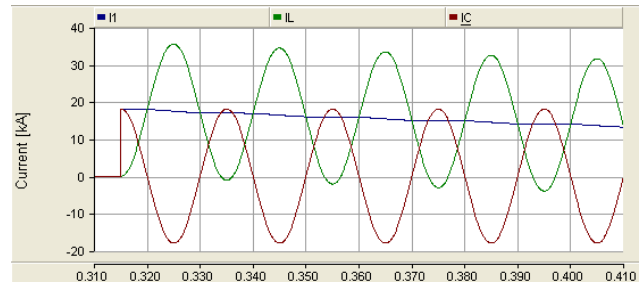

Fig. 4. Current in the inductor (I_L), in the capacitor (I_C) and the sum ($I_I=I_L+I_C$)

The behaviour of a system consisting of a shunt reactor and a cable is not very different from the one depicted in Fig. 3. The shunt reactor can be modelled as an inductor in series with a resistor, and the cable is mainly a capacitive shunt element [5].

The two situations explained before are shown in Fig. 5 and Fig. 6. In Fig. 5 it is shown the current through the circuit breaker and the voltage at the cable's end for a circuit breaker closing a zero voltage, thus there is maximum initial DC component, but no switching overvoltage. Whereas in Fig. 6 are shown the current and the voltage for a circuit breaker closing at peak voltage, resulting in a maximum switching overvoltage (1.75 pu), but no initial DC component.

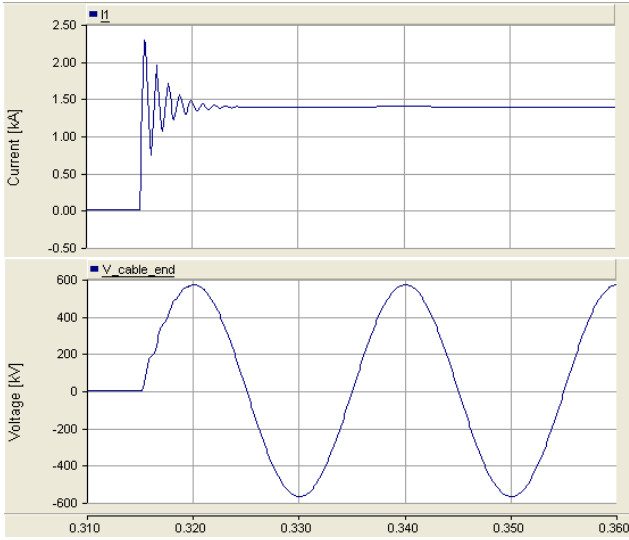

Fig. 5. Current in the circuit breaker and voltage on the end of the cable for a situation of maximum DC component

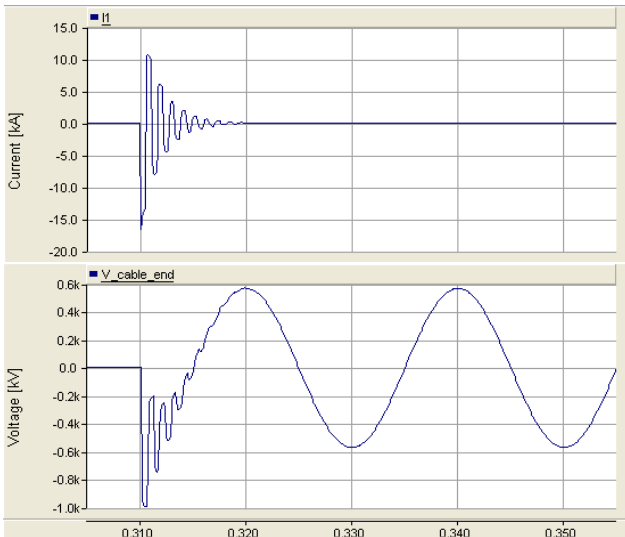

Fig. 6. Current in the circuit breaker and voltage on the end of the cable for a situation of maximum switching overvoltage

B. Energisation of cables in parallel

Electrically, cables are mainly capacitive elements, so the energisation of a cable, when connected to an already energised one, can be seen as being similar to the energisation of capacitor banks in parallel. When energising a capacitor bank that is in parallel with an already energised capacitor bank there will be an inrush current whose amplitude depends of the voltage in the connection moment, and can go up to 100pu [6] or even 200pu [7].

A cable can be modeled as series of RLC circuits like is shown in Fig. 7. As the cable's inductance and resistance are very small the series of "capacitors" on the two cables will be almost in parallel. When in parallel, capacitors should have the same voltage, so part of the charge on the "capacitors" of the energized cable will transfer almost immediately for the "capacitors" of the cable being connected, originating an

inrush current.

This shift of the "capacitor's" charge from one cable to the other is shown in Fig. 7. When the circuit breaker is closed the energy stored in the cable already energized is transferred to the cable being energized, as indicated by the arrows in Fig. 7.

The inrush currents will not be as high as the ones obtained when energizing capacitor banks in parallel, due to the cables' resistance and inductance, which limits the transient and damps it faster.

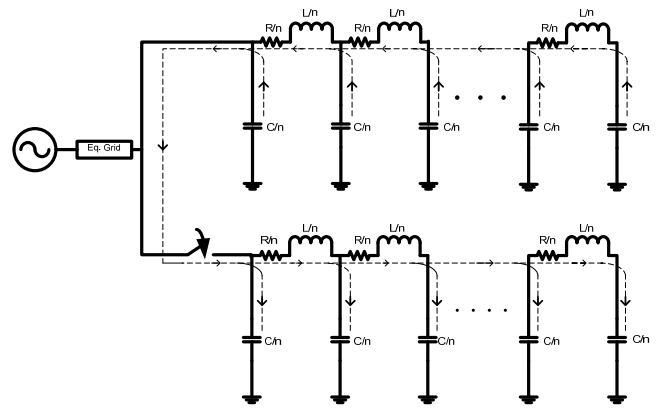

Fig. 7. Cable's energisation equivalent circuit

To demonstrate this phenomenon the energisation of two equal 40km, 72.5kV cables, whose datasheet can be consulted in [8], will be simulated as represented in Fig. 8. The cables are connected in parallel, and in order to reduce the grid influence its short-circuit power is low (a 0.4367Ω resistance and a 31.416Ω reactance), this way there is a larger interaction between the two cables and a smaller one with the grid.

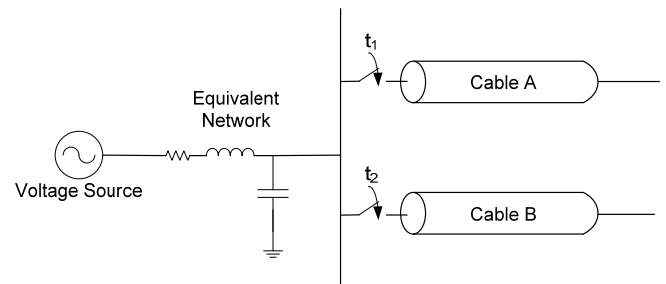

Fig. 8. Energisation of a cable in parallel with an already energized cable ($t_2 \gg t_1$)

The simulation results are presented in Fig. 9 and Fig. 10. Fig. 9 shows the current on the sending end for the energisation of cable A at t_1 , with cable B not connected to the busbar. This situation is similar to the energisation of a single cable and it was explained in the previous sub-section. The current maximum value is around 700A.

At t_2 , after cable A have reached steady-state conditions, cable B is energized. The currents in both cables during the energisation of cable B are shown in Fig. 10.

As can be noticed during the first 0.3ms the currents are

almost symmetrical, meaning that the current being injected in cable B is coming from cable A. It should be observed that when energising a cable in parallel with an already energised cable, the frequency and the currents reach higher peak values that for the energisation of a single cable, the current's amplitude is 1kA when for energisation of a single cable it did not pass the 700A, an increase of 43%.

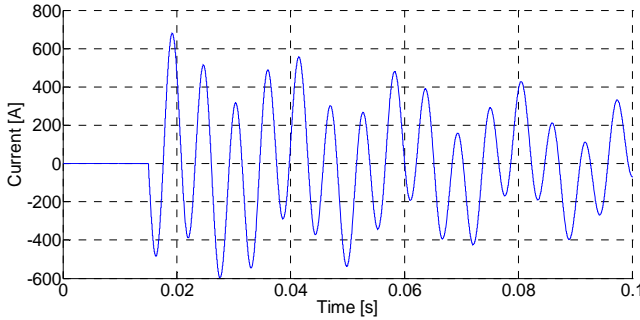

Fig. 9. Current on Cable A sending end during the energisation its energisation

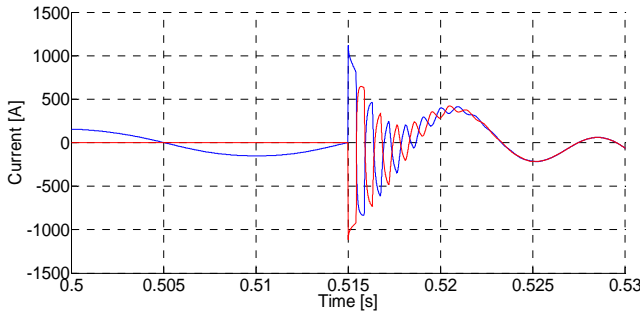

Fig. 10. Currents on the sending ends of Cable A and Cable B during the energisation of Cable B (Blue: Cable A; Red: Cable B)

C. Deenergisation of a single cable

When a cable is disconnected the energy stored in the cable has to be damped, what due to the low cable resistance can take several seconds. When there is a shunt reactor connected directly to the cable, the stored energy will oscillate between the cable and the shunt reactor, with a resonance frequency that can be approximately calculated by (1), where L_{sh} is the shunt reactor inductance and C_{cable} is the cable capacitance. This equation does not consider the cable's inductance, which is small when compared with the shunt reactor inductance.

$$f_r = \frac{1}{2\pi\sqrt{L_{sh}C_{cable}}} \quad (1)$$

This can be verified in Fig. 11 where it is shown the voltage during the cable deenergisation. The shunt reactor compensates 46% of the cable's reactive power, thus using (1) a resonance frequency of approximately 34Hz is expected, and this is the value obtained in the simulation. It can also be noticed in Fig. 11.b that due the low system's resistance it

takes a long time to completely damp the voltage in the cable.

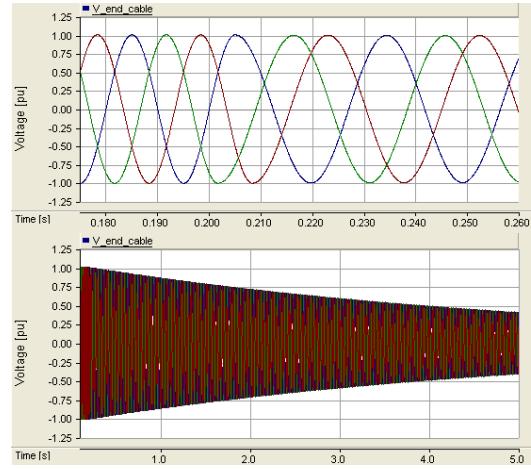

Fig. 11. Voltage in the end of the cable during its deenergisation. a) Zoom of the disconnection moment b) First 5s of the cable's deenergisation

In this situation no overvoltage is expected, but this happens because mutual inductances between the shunt reactor phases were not considered. When the cable is disconnected the three phases are disconnected in different moments, being normally a time difference of 3.333 ms between the disconnection of each phase, if shunt reactor's mutual inductance is considered the system will be unbalanced and overvoltage is expected [9].

When the three phases are connected there is a phase difference of 120° between the three currents (see Fig. 12.a), but after the first phase be disconnected, that phase starts to oscillate at resonance frequency while the other two continue to do it at 50Hz, thus the phase difference is no longer 120° . Because of mutual inductance the voltage in each phase depends of the current in the other two phases, as the system is no longer balance the voltage will become larger in one or two phases while it becomes smaller in the remaining phase(s). The situation with larger overvoltages is the one shown in Fig. 12.b, where the voltage due to self and mutual inductances are aligned generating a maximum voltage.

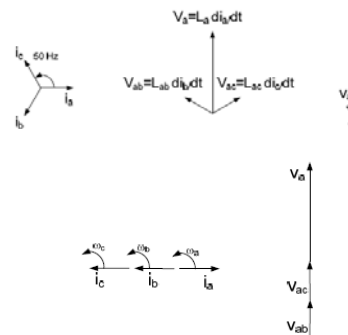

Fig. 12. a) Currents and voltage in phase A when the cable is connected; b) Currents and voltage in phase A, for a possible disconnection

The simulations done previously are repeated but considering a mutual inductance of -0.04H between the phases

of the shunt reactors. The system resonance frequency is 34.25Hz, and the phases are disconnected by the following order A->C->B. In Fig. 13 are shown the voltages after the cable disconnection.

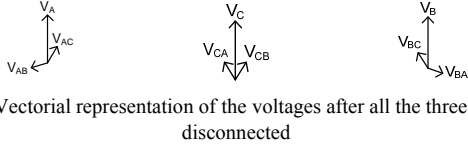

Fig. 13. Vectorial representation of the voltages after all the three phases be disconnected

From Fig. 13 is expected a higher voltage in phase C than in the other two, and this can be verified in Fig. 14 where are shown the simulation plots. Notice that while in the first phase to be disconnected (Phase A) there is no overvoltage in the second (Phase C) the voltage goes up to 1.16pu.

In the analyzed case the mutual inductances were all equal, but in reality they are most likely to be different, unbalancing even more the system. It is also noticed in the figures a low frequency component, this happens because after the disconnection of the last phase, each of the phases resonate at slightly different frequencies, and so due to mutual coupling a modulated low-frequency decaying voltage appears [9].

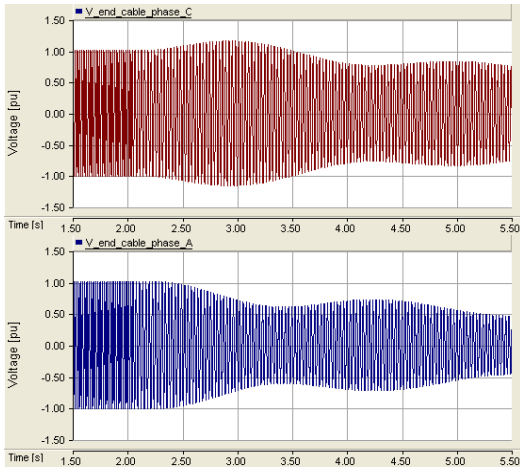

Fig. 14. Voltage in the end of the cable. a) 2nd phase to be disconnected b) 1st phase to be disconnected

D. Series Resonance between cable and transformer

The inductance of a transformer can create a series resonance circuit with the capacitance of a cable. This situation is characterized by low impedance for the harmonic currents at the resonance frequency, what may result in high current distortion and overvoltage if the cable is long enough. The reason for this phenomenon to be more relevant when using underground cables than OHL is because the capacitance is higher on the first ones, and thus the resonance frequency lower.

To simulate this phenomenon is used a 108km cable, connected to a transformer, which is connected to an ideal voltage source. The system is energised two times, with and without the transformer, in both times the three phases are

connected for zero voltage, and no overvoltage is expected. The simulation plots are present in Fig. 15.

When there is no transformer the behaviour is the expected one and there is only a slight overvoltage (Fig. 15.a). But when a transformer is used, and the system cable plus transformer is energized the voltage goes up to 2pu in one of the phases, and higher than 1.7pu in the other two phases (Fig. 15.b). The overvoltage takes several cycles to be damped and is presented in the system for more than 1s, in the simulation the transformer saturation was not activated.

The system frequency spectrum is shown in Fig. 16, being the minimum impedance, i.e. the series resonance point, for a frequency of approximate 80Hz.

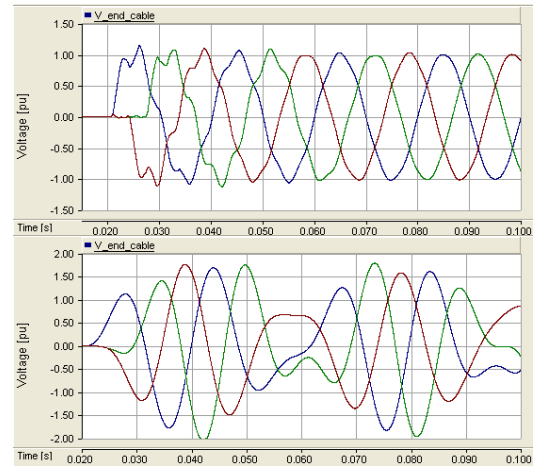

Fig. 15. Voltage in the cable's receiving end during its energization: a) without transformer b) with transformer

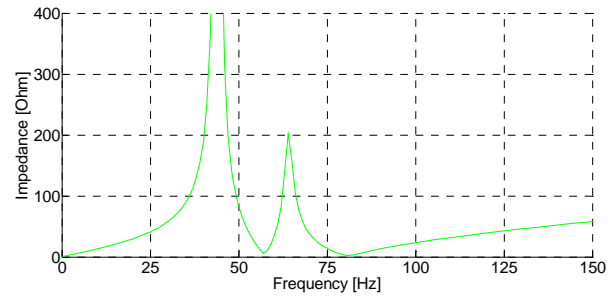

Fig. 16. Frequency Spectrum

During the cable/transformer energisation there is an energy exchange between the system's inductance and capacitance at system resonance frequency. The main voltage harmonic continues to be the fundamental, but the high current that appear at the resonance frequency originates voltages with the same frequency, which when added to the fundamental distort the voltage and create the temporary overvoltage presented on Fig. 15.b.

The simulation was made without transformer saturation, if it saturates other harmonic currents would be injected in the system what may increase the overvoltage a little more.

V. CONCLUSIONS

Several non-desirable phenomena are associated with HV underground cables transients. These transients may reduce the lifetime or even damages cables and remaining network equipment. Thus they must be attended when planning and operating the electric grid.

This paper presents several of those phenomena, showing how overvoltages and inrush currents can appear in systems based on HVAC cables. The phenomena were presented for simple systems, consisting in no more than two cables, shunt reactor and transformer. A real grid is much more complex, and thus in reality these phenomena may be even more dangerous for the network.

Therefore, countermeasures and mitigation methods have to be study under the risk of in the future having instead constant fails and damages in the grid.

VI. REFERENCES

- [1] Energinet.dk, "Kabelhandlingsplan 132-150 kV", 2009, (in Danish)
- [2] ELINFRASTRUKTURUDVALGET, " Technical report on the future expansion and undergrounding of the electricity transmission grid", Appil 2009
- [3] Alan Greenwood, "Electric Transients in Power Systems", John Wiley & Sons, 1st Edition, 1971
- [4] J. F. Borges da Silva, "Electrotecnia Teórica - 1ª Parte", 2nd edition, AEIST, 1995 (in Portuguese)
- [5] J. H. R. Enslin, Yi Hu, R. A. Wakefield, "System Considerations and Impacts of AC Cable Networks on Weak High Voltage Transmission Networks", *Transmission and Distribution Conference and Exhibition, 2005/2006 IEEE PES*, May 2006
- [6] *IEEE Guide for the Protection of Shunt Capacitor Banks*, IEEE Standard C37.99-2000, 2000
- [7] C. D. Tsirekis, N. D. Hatzargyriou, "Control of Shunt Capacitors and Shunt Reactors Energization Transients", IPST 2003
- [8] 60-500kV High voltage Underground Power Cables: XLPE Insulated Cables, Nexans
- [9] Claus L. Bak, Wojciech Wiechowski, Kim Sogaard, Søren D. Mikkelsen, "Analysis and simulation of switching surge generation when disconnecting a combined 400kV cable/overhead line with shunt reactor", IPST 2001