



Aalborg Universitet

AALBORG UNIVERSITY
DENMARK

Ambient Response Analysis of the Heritage Court Tower Building Structure

Brincker, Rune; Andersen, P.

Published in:

IMAC 18 : Proceedings of the International Modal Analysis Conference (IMAC), San Antonio, Texas, USA, February 7-10, 2000

Publication date:

2000

Document Version

Publisher's PDF, also known as Version of record

[Link to publication from Aalborg University](#)

Citation for published version (APA):

Brincker, R., & Andersen, P. (2000). Ambient Response Analysis of the Heritage Court Tower Building Structure. In IMAC 18 : Proceedings of the International Modal Analysis Conference (IMAC), San Antonio, Texas, USA, February 7-10, 2000 (pp. 1081-1087)

General rights

Copyright and moral rights for the publications made accessible in the public portal are retained by the authors and/or other copyright owners and it is a condition of accessing publications that users recognise and abide by the legal requirements associated with these rights.

- ? Users may download and print one copy of any publication from the public portal for the purpose of private study or research.
- ? You may not further distribute the material or use it for any profit-making activity or commercial gain
- ? You may freely distribute the URL identifying the publication in the public portal ?

Take down policy

If you believe that this document breaches copyright please contact us at vbn@aub.aau.dk providing details, and we will remove access to the work immediately and investigate your claim.

Ambient Response Analysis of the Heritage Court Tower Building Structure

Rune Brincker
Department of Building Technology and Structural Engineering
Aalborg University
Sonhgaardsholmsvej 57, DK 9000, Aalborg

Palle Andersen
Structural Vibration Solutions ApS
NOVI Science Park,
Niels Jernes Vej 10, DK 9220 Aalborg East, Denmark

Abstract

In this paper an ambient response analysis of the Heritage Court Building structure is presented. The work is a part of a blind test organised by Professor Carlos Ventura, University of British Columbia. The response data were analysed using two different techniques: a non-parametric based on Frequency Domain Decomposition (FDD), and a parametric technique working on the raw data in time domain, a data driven Stochastic Subspace Identification (SSI) algorithm. Both techniques identified 11 modes under 10 Hz. One case of three close modes and one case of two close modes were identified. For all modes, natural frequencies identified by the two techniques showed good agreement, mode shape estimates were nearly identical, and damping ratios reasonably close and around 1-2 % in the most cases.

Nomenclature

Δt	sampling time step
y_i	response vector
f	natural frequency
ζ	damping ratio
Φ, Ψ	mode shape matrices

Introduction

When modal properties are to be identified from large structures, usually the possibilities to control and measure the loading on the structure is rather limited. This is especially true for a building structure where artificial loading is difficult to apply without introducing a significant risk of damaging the structure.

Thus, in this case, it is preferable that the modal properties are determined by analysing the ambient responses of the building, i.e. the responses due to unknown loading from wind, people moving around in the building, traffic crossing by etc.

Several real cases of ambient response analysis can be found in Ventura and Horyna [2], and a comparison between different techniques for modal identification from ambient responses can be found in Andersen et al. [3].

For this particular building structure, the loading is unknown, it is not measured and it is not known what kind of loading is dominating. A description of the how the tests of the structure were performed can be found in Dyck and Ventura [1].

The response data were analysed using two different techniques: a non-parametric technique based on Frequency Domain Decomposition (FDD), and a parametric technique working on the raw data in time domain, a data driven Stochastic Subspace Identification (SSI) algorithm.

The results from the two techniques were compared and validated against each other.

Principle of Frequency Domain Decomposition (FDD)

The Frequency Domain Decomposition (FDD) technique is an extension of the classical frequency domain approach often referred to as the Basic Frequency Domain (BFD) technique, or the peak picking technique. The classical approach is based on simple signal processing using the Discrete Fourier Transform, and is using the fact, that well separated modes can be estimated directly from the power spectral density matrix at the peak.

In the FDD technique first the spectral matrix is formed from the measured outputs using simple signal processing by discrete Fourier Transform (DFT). However, instead of using the spectral density matrix directly like in the classical approach, the spectral matrix is decomposed at every frequency line using Singular Value Decomposition (SVD). By doing so the spectral matrix is decomposed into a set of auto spectral density functions, each corresponding to a single degree of freedom (SDOF) system. This is exactly true in the case where the loading is white noise, the structure is lightly damped, and where the mode shapes of close modes are geometrically orthogonal. If these assumptions are not satisfied, the decomposition into SDOF systems is an approximation, but still the results are significantly more accurate than the results of the classical approach.

The singular vectors in the SVD are used as estimates of the mode shape vectors, and the natural frequencies are estimated by taking each individual SDOF auto spectral density function back to time domain by inverse DFT. The frequency and the damping were simply estimated from the crossing times and the logarithmic decrement of the corresponding SDOF auto correlation function.

The theoretical background of the FDD technique is described in Brincker et al [4].

Results of Frequency Domain Decomposition (FDD)

Figure 1 shows the singular value decomposition of the spectral density matrix of the first set-up. In this identification, the first set-up had 6 channels of response measurements. Thus, the decomposition results in 6 singular values.

As it appears, 3 singular values are coming up around 1.1-1.4 Hz. This clearly indicates the presence of 3 modes in this range. The rest of the modes are reasonable separated except the two modes around 7.5 Hz. The first mode is present in the first singular value, the other mode is present in the second singular value, the second being weakly excited and hiding behind the dominating mode. The small but sharp peak around 8.3 Hz could be a mode, but it is not clearly identified as a mode using the FDD technique. If it is a mode, the mode shape seems to be a pure torsion mode with a wavelength a little shorter than the building height.

Damping and natural frequencies are given in Table 1, and mode shapes are shown in Figures 3-6.

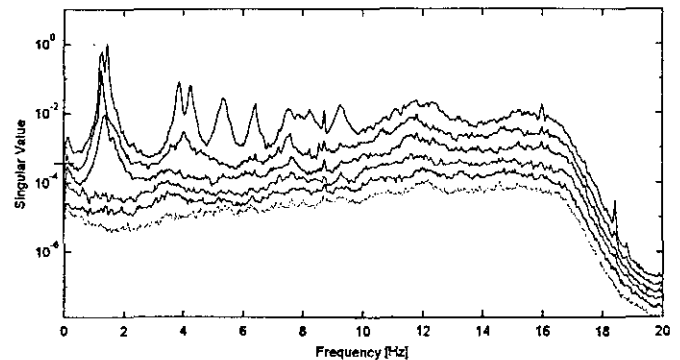

Figure 1. Singular value decomposition of the spectral density matrix of the first set-up.

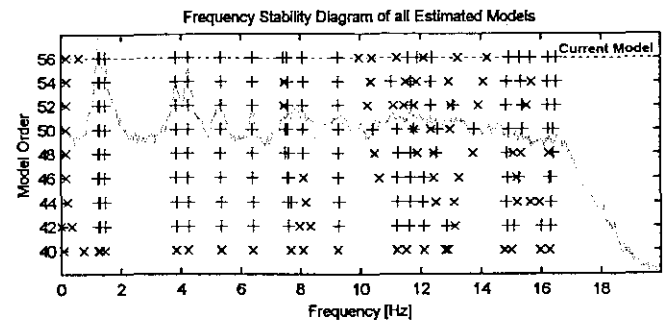

Figure 2. Stabilisation diagram of the first set-up.

Principle of Stochastic Subspace Identification (SSI)

Stochastic Subspace Identification (SSI) is a class of techniques that are all formulated and solved using state space formulations of the form

$$x_{t+1} = Ax_t + w_t$$

$$y_t = Cx_t + v_t$$

where x_t is the Kalman sequences that in SSI is found by a so-called orthogonal projection technique, Overschee and De Moor [6]. Next step is to solve the regression problem for the matrices A and C , and for the residual sequences w_t and v_t . Finally, in order to complete a full covariance equivalent model in discrete time, the Kalman gain matrix K is estimated to yield

$$\hat{x}_{t+1} = A\hat{x}_t + Ke_t$$

$$y_t = C\hat{x}_t + e_t$$

It can be shown, Brincker and Andersen [5], that by performing a modal decomposition of the A matrix as $A = V[\mu_i]V^{-1}$ and introducing a new state vector $z_t = V^{-1}\hat{x}_t$, the equation can also be written as

$$z_{t+1} = [\mu_i]z_t + \Psi e_t$$

$$y_t = \Phi z_t + e_t$$

where $[\mu_i]$ is a diagonal matrix holding the discrete poles related to the continuous time poles λ_i by $\mu_i = \exp(\lambda_i \Delta t)$, and where the matrix Φ is holding the left hand mode shapes (physical, scaled mode shapes) and the matrix Ψ is holding the right hand mode shapes (non-physical mode shapes). The right hand mode shapes are also referred to as the initial modal amplitudes, Juang [7].

The specific technique used in this investigation is the Principal Component algorithm, see Overschee and De Moor [6].

Results of Stochastic Subspace Identification (SSI)

For each set-up a set of models with different model orders are identified and the stabilisation diagram is established. Figure 2 shows the stabilisation diagram for set-up one.

As it appears, clearly there are three modes present around 1.1-1.4 Hz, the first two modes being quite close. Further it appears, that the first 7 modes are well defined, they are repeated without variance in all models. Around 7.5 Hz two close modes are clearly present, however they are not determined with the same accuracy as the first modes. The last two modes are pretty well defined.

Damping and natural frequencies are given in Table 1, and mode shapes are shown in Figures 3-6.

Conclusions

Eleven modes have been identified using both techniques. Both techniques clearly indicate three close modes around 1.1-1.4 Hz, a translation mode, one mode nearly pure torsion, and a mode of combined torsion and translation.

Two close modes are clearly indicated around 7.5 Hz, the mode shapes for the two modes being somewhat uncertain. The mode shapes for the rest of the modes show good agreement comparing the two techniques.

Damping ratios show a reasonably good agreement in the most cases, values estimated around 1-2 %. For mode 3 a relatively high value of 3.4 % has been estimated. This value might be uncertain due to the difficulties introduced by the close mode problem. All other damping estimates are believed to be reliable estimates.

References

- [1] Dyck, Cheryl and Carlos E. Ventura: "Ambient Vibration Measurements of Heritage Court Tower". EQ LAB, University of British Columbia, Earthquake Engineering Research, September 1998.
- [2] Ventura, Carlos E. and Tomas Horyna: "Structural Assessment by Modal Analysis in Western Canada", Proc. of the 15th International Modal Analysis Conference, Orlando, Florida, Orlando, 1997.
- [3] Andersen, P, R. Brincker, B. Peeters, G. De Roeck, L. Hermans and C. Krämer: "Comparison of system Identification Methods Using Ambient Bridge Test Data", Proc. of the 17th International Modal Analysis Conference, Kissimee, Florida, 1999.
- [4] Brincker, R., L. Zhang and P. Andersen: "Modal Identification from Ambient Responses using Frequency Domain Decomposition, Proc. of the 18th International Modal analysis Conference, San Antonio, Texas, February 7-10, 2000.
- [5] Brincker, R. and P. Andersen: "ARMA Models in Modal Space", Proc. of the 17th International Modal Analysis Conference, Kissimee, Florida, 1999.
- [6] Overschee, Van P., and B. De Moor: "Subspace Identification for Linear Systems", Kluwer Academic Publishers, 1996.
- [7] Juang, J.N.: "Applied System Identification", Prentice Hall, Englewood Cliffs, New Jersey, 1994.

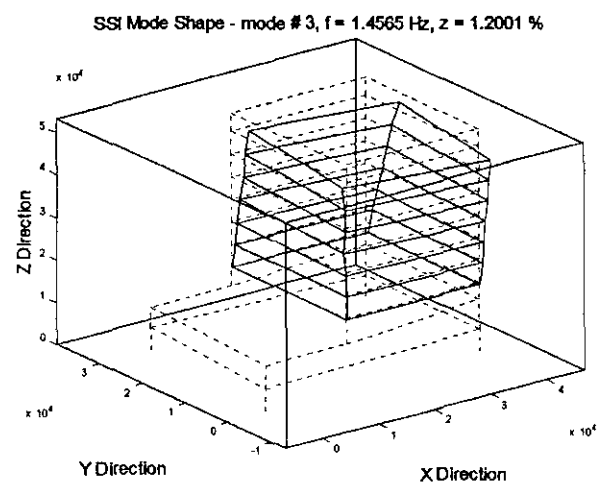
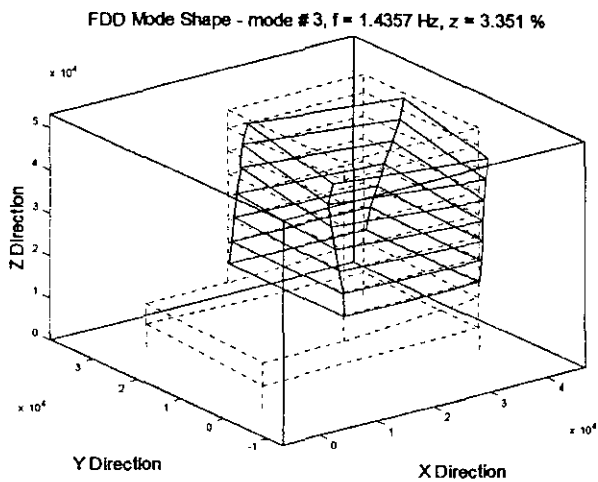
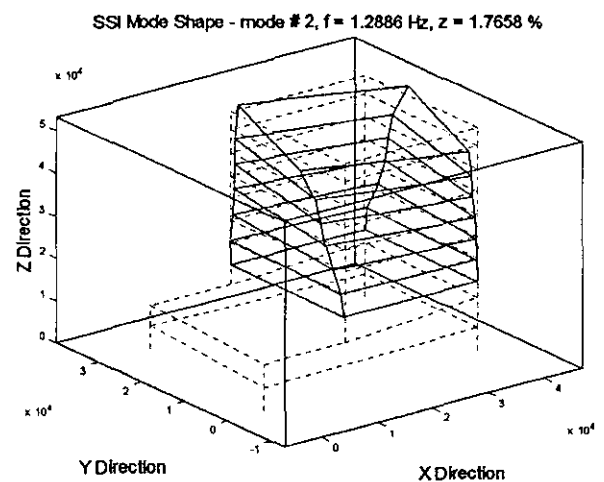
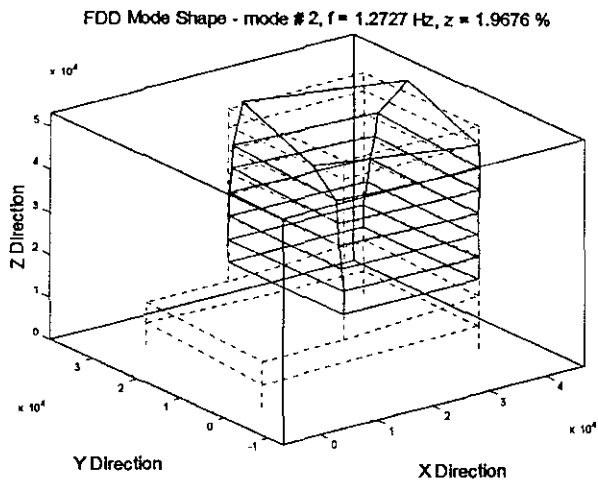
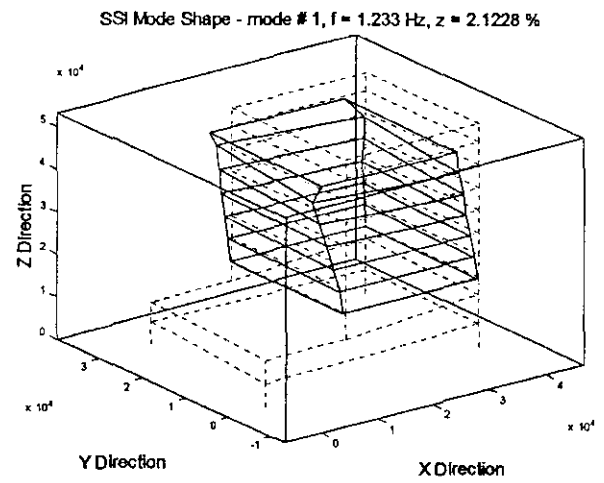
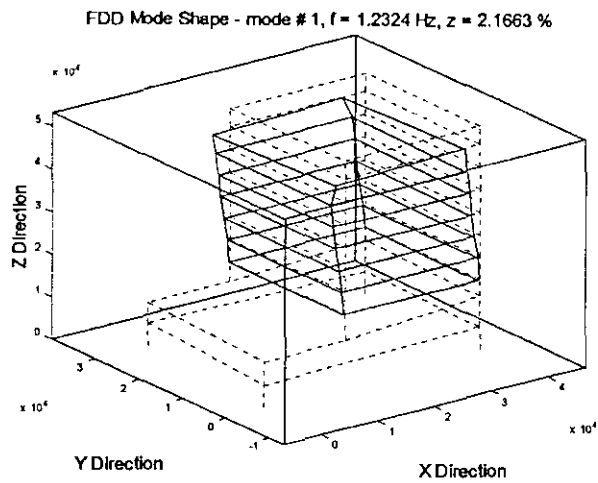

Figure 3. Mode 1-3, left: Results of Frequency Domain Decomposition (FDD), right: Results of Stochastic Subspace Identification (SSI)

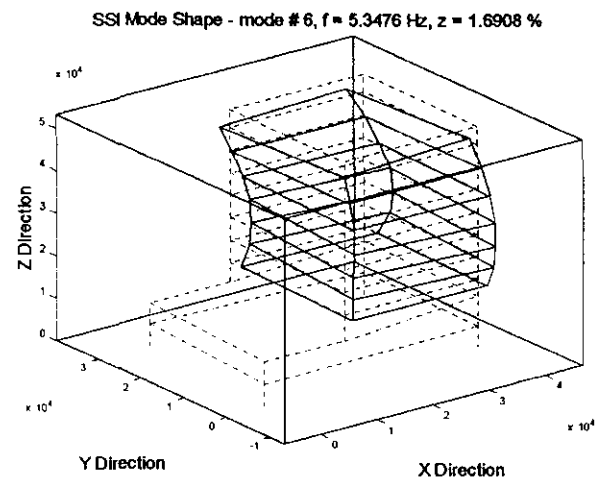
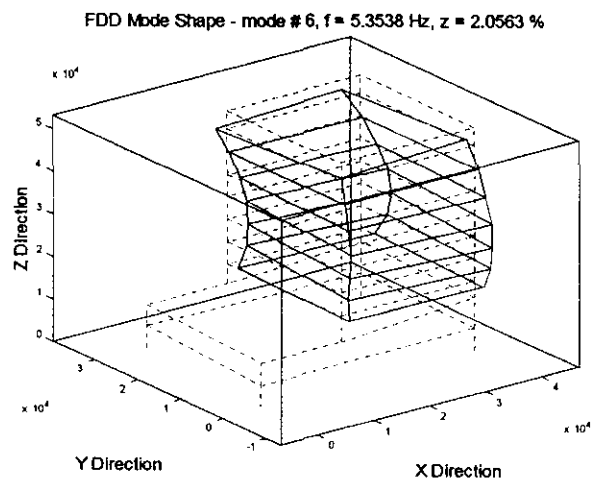
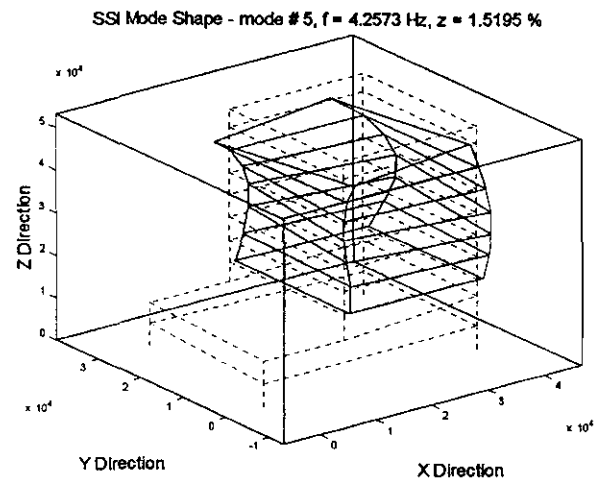
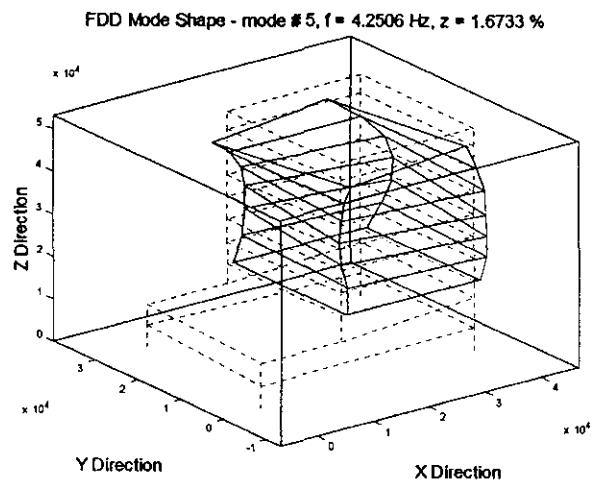
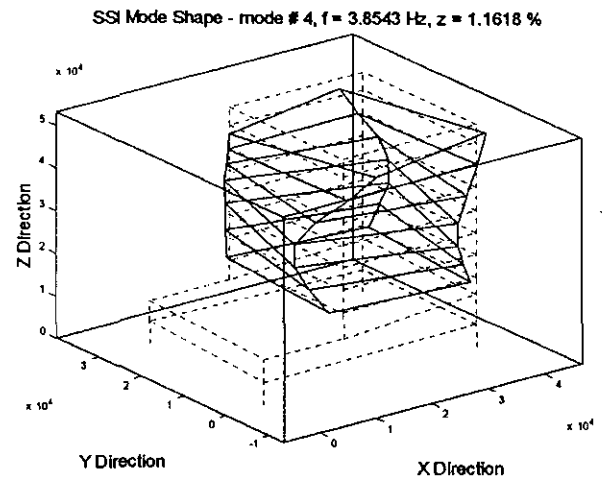
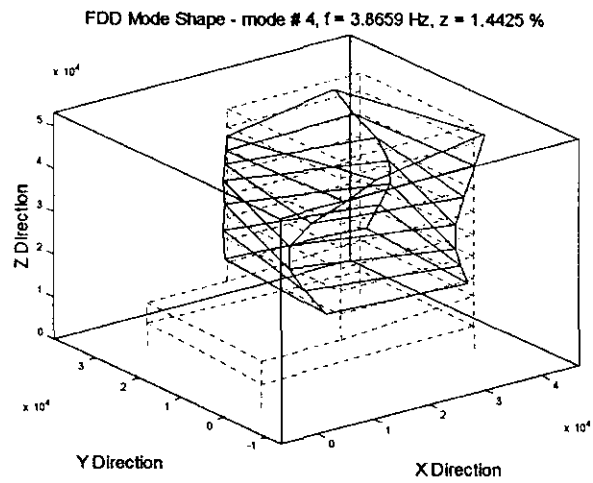

Figure 4. Mode 4-6, left: Results of Frequency Domain Decomposition (FDD), right: Results of Stochastic Subspace Identification (SSI)

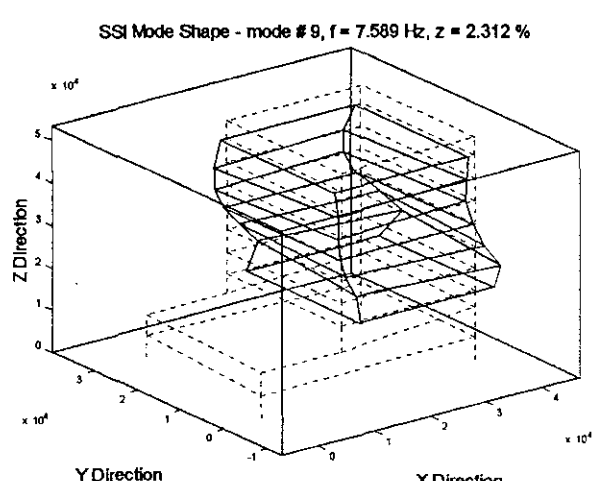
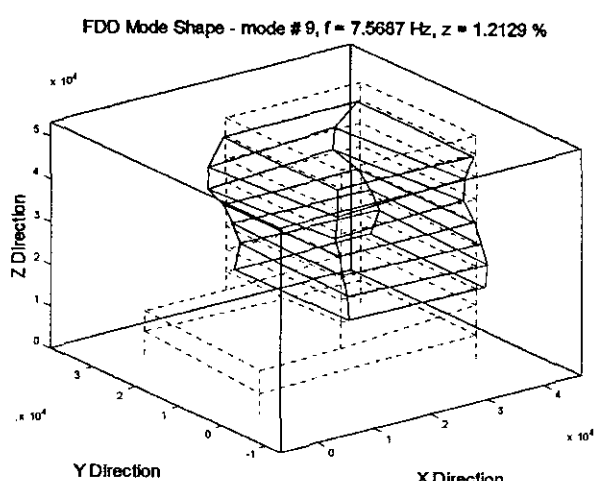
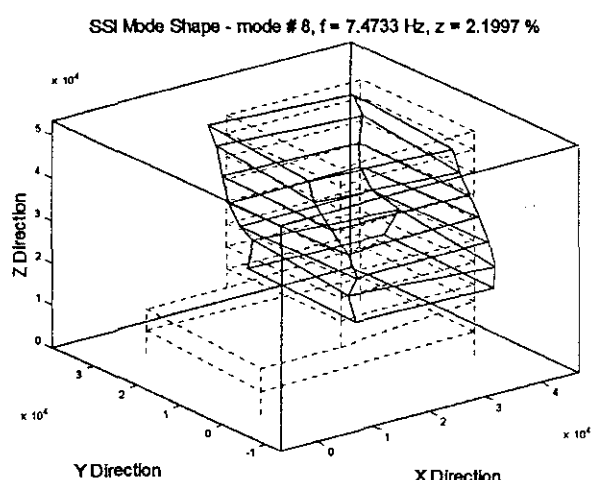
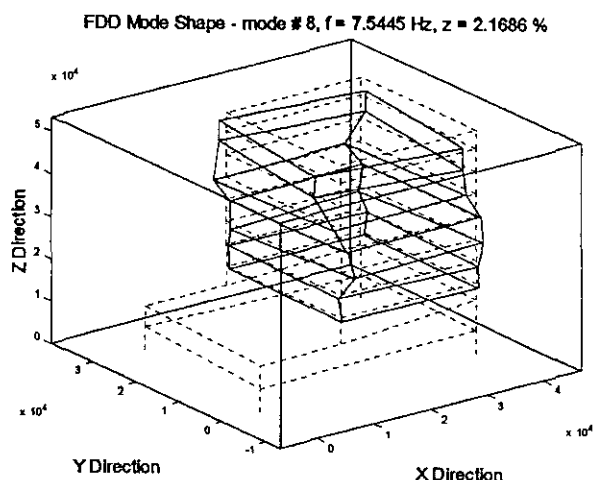
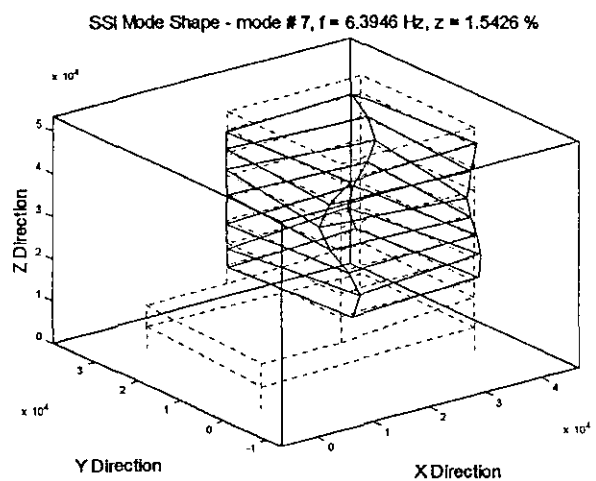
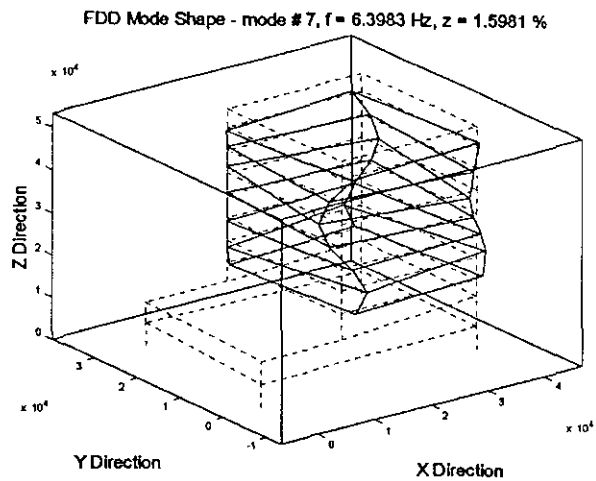

Figure 5. Mode 7-9, left: Results of Frequency Domain Decomposition (FDD), right: Results of Stochastic Subspace Identification (SSI)

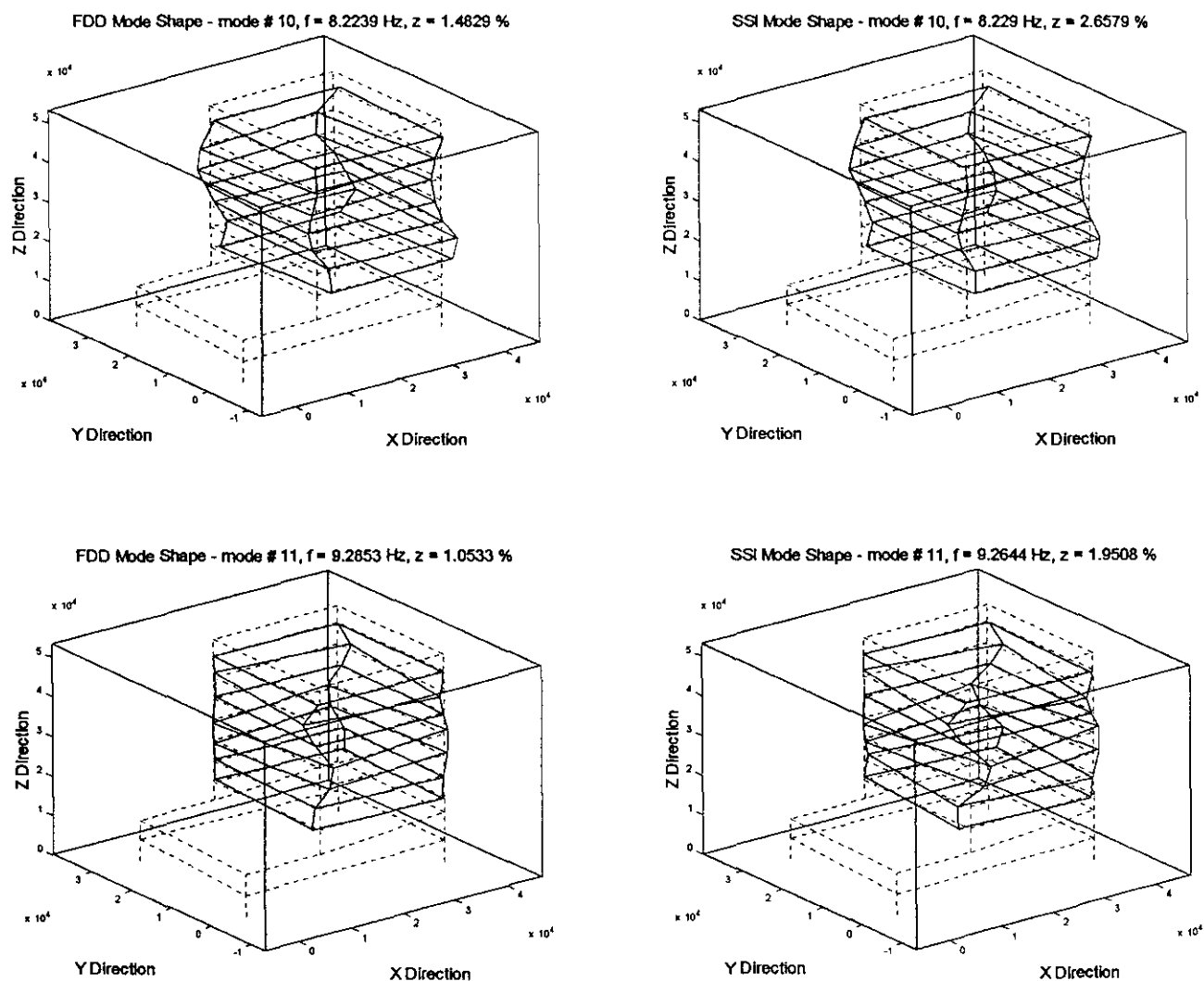

Figure 6. Mode 10-11, left: Results of Frequency Domain Decomposition (FDD), right: Results of Stochastic Subspace Identification (SSI).

Table 1. Natural frequencies and damping ratios of all estimated modes

Mode No	Frequency Domain Decomposition (FDD)		Stochastic Subspace Identification (SSI)	
	Frequency f (Hz)	Damping ζ (%)	Frequency f (Hz)	Damping ζ (%)
1	1.232	2.17	1.233	2.12
2	1.273	1.97	1.289	1.77
3	1.436	3.35	1.457	1.20
4	3.866	1.44	3.854	1.16
5	4.251	1.67	4.257	1.52
6	5.354	2.06	5.348	1.69
7	6.398	1.60	6.395	1.54
8	7.545	2.17	7.473	2.20
9	7.569	1.21	7.589	2.31
10	8.224	1.48	8.229	2.66
11	9.285	1.05	9.264	1.95