



**AALBORG UNIVERSITY**  
DENMARK

**Aalborg Universitet**

## **A Survey on Control of Electric Power Distributed Generation Systems for Microgrid Applications**

Bouزيد, Allal; Guerrero, Josep M.; Cheriti, Ahmed; Bouhamida, Mohamed; Sicard, Pierre; Benghanem, Mustapha

*Published in:*  
Renewable & Sustainable Energy Reviews

*DOI (link to publication from Publisher):*  
[10.1016/j.rser.2015.01.016](https://doi.org/10.1016/j.rser.2015.01.016)

*Publication date:*  
2015

*Document Version*  
Early version, also known as pre-print

[Link to publication from Aalborg University](#)

*Citation for published version (APA):*  
Bouزيد, A., Guerrero, J. M., Cheriti, A., Bouhamida, M., Sicard, P., & Benghanem, M. (2015). A Survey on Control of Electric Power Distributed Generation Systems for Microgrid Applications. *Renewable & Sustainable Energy Reviews*, 44, 751–766. DOI: 10.1016/j.rser.2015.01.016

### **General rights**

Copyright and moral rights for the publications made accessible in the public portal are retained by the authors and/or other copyright owners and it is a condition of accessing publications that users recognise and abide by the legal requirements associated with these rights.

- ? Users may download and print one copy of any publication from the public portal for the purpose of private study or research.
- ? You may not further distribute the material or use it for any profit-making activity or commercial gain
- ? You may freely distribute the URL identifying the publication in the public portal ?

### **Take down policy**

If you believe that this document breaches copyright please contact us at [vbn@aub.aau.dk](mailto:vbn@aub.aau.dk) providing details, and we will remove access to the work immediately and investigate your claim.

# A Survey on Control of Electric Power Distributed Generation Systems for Microgrid Applications

Allal M. Bouzid<sup>1,2</sup>, Josep M. Guerrero<sup>3</sup>, Ahmed Cheriti<sup>2</sup>, Mohamed Bouhamida<sup>1</sup>, Pierre Sicard<sup>2</sup>, and Mustapha Benghanem<sup>1</sup>

<sup>1</sup> Department of Electrical Engineering, Université des Sciences et de la Technologie d'Oran, Algeria

<sup>2</sup> Department of Electrical & Computer Engineering Université du Québec à Trois-Rivières (Québec), Canada

<sup>3</sup> Department of Energy Technology, Aalborg University, Aalborg East 9220, Denmark

**Corresponding author:** Allal M. Bouzid, Department of Electrical & Computer Engineering Université du Québec à Trois-Rivières (Québec), Canada, Tel : +1-819-701-0827, Email : allalbouzid@live.fr, Allal.El.Moubarek.Bouzid@uqtr.ca

**Abstract**—The introduction of microgrids in distribution networks based on power electronics facilitates the use of renewable energy resources, distributed generation (DG) and storage systems while improving the quality of electric power and reducing losses thus increasing the performance and reliability of the electrical system, opens new horizons for microgrid applications integrated into electrical power systems. The hierarchical control structure consists of primary, secondary, and tertiary levels for microgrids that mimic the behavior of the mains grid is reviewed. The main objective of this paper is to give a description of state of the art for the distributed power generation systems (DPGS) based on renewable energy and explores the power converter connected in parallel to the grid which are distinguished by their contribution to the formation of the grid voltage and frequency and are accordingly classified in three classes. This analysis is extended focusing mainly on the three classes of configurations grid-forming, grid-feeding, and grid-supporting. The paper ends up with an overview and a discussion of the control structures and strategies to control distribution power generation system (DPGS) units connected to the network.

**Keywords**— Distributed power generation system (DPGS); hierarchical control; grid-forming; grid-feeding; grid-supporting.

Nomenclature		HES	Hybrid Energy System
Symbols		ILC	Iterative learning control
$i_d - i_q$	Current (A)	IMP	Internal model principle
$V_d - V_q$	Voltage (Volt)	IRSMC	Integral resonant sliding mode controller
P	Power (Watt)	LQG	Linear quadratic Gaussian
Q	Power (Var)	LQ	Linear Quadratic
$\omega$	Pulsation (rad/s)	LQR	Linear Quadratic Regulator
E	Voltage (Volt)	MG	Microgrid
f	Frequency (Hz)	NPC	Neutral-point-clamped
U	Voltage (Volt)	NN	Neural network
Abbreviations		NNIPI	Neural network interfacing-parameters identifier
AC	Alternating current	NNGVE	Neural network grid-voltage estimator
CHP	Combined heat and power	PI	Proportional integral
DB	Deadbeat	PID	Proportional integral derivative
DC	Direct current	PR	Proportional resonant
DER	Distributed energy resources	PWM	Pulse width modulation
DG	Distributed generation	PCC	Point of common coupling
DPC	Direct power control	PED	Power electronics device
DPGS	Distributed power generation systems	RC	Repetitive feedback control
$dq$	Park transformation	SISO	Single-input single-output
EES	Electrical energy storage	SMC	Sliding mode controller
FACTS	Flexible AC transmission system	THD	Total harmonic distortion
FIR	Finite impulse response	UPS	Uninterruptible power supply
HC	Harmonic compensator	VSC	Voltage-source converters
		VPP	Virtual power plants

## 1. INTRODUCTION

Today, there is an increasing use of small-scale renewable power sources into modern electric grids, because the current growing demands for electrical energy [1, 2]. Photovoltaics, wind power and hydroelectricity are three of the renewable energies that are mostly used; they are clean for the environment and inexhaustible. This renewable energy has experienced rapid technological development, which makes them at affordable prices. This advantage allows the energy security of countries to reduce imports of fossil fuels, which agrees to maintain a lower cost than usual prices and improve the standard of living without harming the

environment, especially in a time when the economic crisis is timely. Another advantage, they can easily support the electrical network in remote sites and rural areas [2]. As shown in Fig. 1, or the rate of investment of wind energy was more important in 2010, but he started dropped in 2012 and 2013 to 12% in contrast to the solar energy that has experienced the same problem a year later compared to the wind, despite the economic problems many countries support programs connecting renewable energy with global and local power grid. In order to integrate different kinds of renewable energy sources, the concept of microgrid (MG) was proposed several years ago [3]. A microgrid can be defined as a part of the grid consisting of prime energy movers, power electronics converters, distributed energy storage systems, and local loads [4].

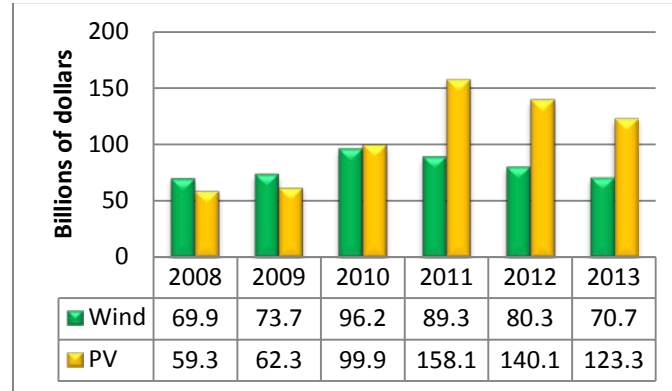

Fig. 1. Global investment in wind and photovoltaic

This makes the electrical network more flexible and intelligent [5]. Microgrids and virtual power plants (VPPs) are two low voltage distribution network concepts that can participate in active network management of a smart grid [6, 7]. They are becoming an important concept to integrate distributed generation (DG) and energy storage systems [5, 8]. The interest of DG grows and is taking importance [9] when it is composed of different energy resources: Photovoltaics, wind power and hydroelectrics with electrical energy storage (EES) (e.g., batteries or super capacitors) [6] forming a Hybrid Energy System (HES) [2], because they can easily support the electrical network in island mode and rural areas or grid-connection mode. Other non-renewable based power systems (diesel or gas), whose generation profile can be easily controlled are also likely to be integrated into microgrids [10]. This gives the user the possibility to produce and storage part of the electrical power of the whole system [9]. The use of DPGS of energy systems makes no sense without using distributed storage systems to cope with the energy balances [5]. Microgrids should be able to locally solve energy problems and hence increase flexibility [11]. The advance carried in recent years in power electronics makes this latter very attractive when integrating renewable energy resources, distributed energy storage systems and active loads [4, 12]. The Power Electronic Converters are typically used as interfaces between these devices and the MG, acting as a voltage source (voltage source inverter VSI, in the case of AC network micro) [3, 8, 12]. MGs need to be able to operate intelligently in both grid and island mode [13]. At the same time, AC and DC sources sometimes coexist in a practical microgrid. the interfacing converters are usually connected in parallel [3]. The control of the parallel VSIs forming a MG has been investigated in last years [12]. Thus, the greatest challenge is to ensure a stability and voltage regulation for offering a better power quality for the customer [9]. In order to avoid circulating currents among the converters without using any critical communication between them, the droop-control method is often applied [5, 11]. This is a kind of collaborative control used for share active and reactive power between VSIs in a cooperative way [12]. These control loops, also called  $P - \omega$  and  $Q - E$  droops, have been applied to connect inverters in parallel in uninterruptible power supply (UPS) systems to avoid mutual control wires while obtaining good power sharing [5, 11, 14, 15]. However, although this technique achieves high reliability and flexibility, but the price to pay is that the sharing is obtained through voltage and frequency deviations of the system (load dependent frequency and amplitude deviations) [12, 16, 17] this that limit its application [5, 11]. In order to solve these problems, an external control loop named secondary control is implemented in the microgrid central control to restore the nominal values frequency and amplitude in the microgrid [4, 5, 11, 12]. An additional tertiary control can be used to bidirectional control the power flowing. In case of AC microgrids the objective is to regulate the power flows between the grid and the microgrid at the point of common coupling (PCC) [5, 11, 18, 19]. In countries with hydro power potential, small hydro turbines are used at the distribution level, in order to sustain the utility network in dispersed or remote locations [20]. At present time, most of renewable based DG units directly produce DC or variable frequency/voltage AC output power and hence power electronics devices (PEDs) have become the key elements in order to realize the MGs [21]. But the increased amount of DPGS based on wind turbine and photovoltaic are connected to the utility network and can create instability in the power systems because of the variation of the wind and sun. In order to maintain a stable power system in countries with a large penetration of distributed power, transmission system operators issue more stringent demands regarding the interconnection of the DPGS to the utility grid [22]. Besides their low efficiency, the controllability of the DPGS based on both wind and sun are their main drawback [23]. As a consequence, their connection to the utility network can lead to grid instability or even failure, if these systems are not properly controlled. Moreover, the standards for interconnecting these systems to the utility network are stressing more and more the capability of the DPGS to run over short grid disturbances [20]. This

document provides the structure of a DGPS system based on renewable energy, with the properties of these two important parts (input / grid side controller). Section III presents the overview and Design of the Hierarchical Control of Micro-Grid. Followed by the contribution of the power inverter to the formation of the grid voltage and frequency. Mainly focusing on the three classes of: grid-forming configurations, grid-feeding, and grid-supporting. Finally, we finish with a state of the art of the control structures and strategies to (DGPS) connected to network.

## 2. INTRODUCTION TO MICROGRID

Microgrids are emerging as an integral feature of the future power systems shaped by the various smart-grid initiatives [24]. This is new approach to the integration of distributed energy resources (DER) due to the rapid growth of systems of decentralized energy production and thus opening promising perspectives in the sustainable energy sector. A microgrid can be considered as a local grid, it is formed by integrating loads, multiple distributed generators (DGs), ESS could also be used to control the net power flows to and from the utility in the grid connected mode [25]. Such microgrids also include the flexible AC transmission system (FACTS) control devices such as power flow controllers and voltage regulators as well as protective relays and circuit breakers [26]. The MG is able to operate either in grid-connected or islanded mode, with possibility of seamless transitions between them. An important advantage of microgrids is improving energy efficiency with the system of producing combined heat and power (CHP) combined, which captures thermal energy resulting from the production of electricity for a variety of heating needs (hot water steam, heating and cooling), which provides opportunities to optimize the DGPS [27, 28]. The microgrid is responsible to provide and ensure these criteria [29-31]

- Increase energy efficiency and efficiency;
- Insured that the microsources feed the electrical loads; offers and optimizes heat utilization for local installation;
- Insure that the microgrid satisfies operational contracts with the utility;
- Minimize emissions and/or system losses;
- Enhance the robustness of the distribution system and maximize the operational efficiency and local reliability;
- Facilitate greater use of renewable (wind and photovoltaic systems);
- Active and reactive powers are transferred according to necessity of the microgrids and/or the distribution system;
- Disconnection and reconnection processes are conducted seamlessly;
- In case of general failure, the microgrid is able to operate through black-start.

A microgrids is an interconnection of distributed energy sources, such as micro turbines, wind turbines, fuel cells and PVs integrated with storage devices, such as batteries, flywheels and power capacitors on low voltage distribution systems [32]. Each feeder has circuit breaker and power flow controller. The basic microgrid architecture is shown in Fig. 2.

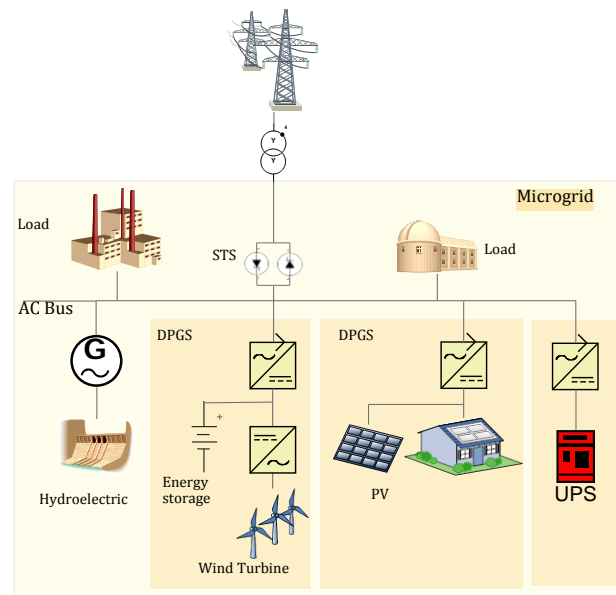

Fig. 2. The basic AC microgrid architecture

The microgrid offers a number of important advantages and provided a new paradigm for future distribution power systems, these advantages are enumerated as following [33, 34]:

- A major advantage of a Microgrid, is its ability, during a utility grid disturbance, to separate and isolate itself from the utility seamlessly with little or no disruption to the loads within the Microgrid;
- Contributes to optimize the general operation of the system;
- In peak load periods it prevents utility grid failure by reducing the load on the grid;
- Significant environmental benefits made possible by the use of low or zero emission generators;
- The use of both electricity and heat permitted by the close proximity of the generator to the user, thereby increasing the overall energy efficiency;
- Microgrid can act to mitigate the electricity costs to its users by generating some or all of its electricity needs;
- Enhancing the quality of power which is delivered to sensitive loads [35].

Despite the fact that the AC micro-grid system have a large number of benefit but its application involves some problems of low efficiency and several disadvantages, these very challenging problems are listed bellow [29, 36-41]:

- Major drawbacks to increased DER utilization are
  - High cost and net metering may pose obstacles for Microgrid.
  - The need for custom engineering,
  - Interconnection standards needs to be developed to ensure consistency.
- The control and protection hardware are one of the most important challenges for facing the implementation of Microgrids and ensure the supplying of the customers in island mode;
- Resynchronization with the utility grid is difficult [37, 42]:
  - The ability to maintain synchronism after transition to island operation is crucial from stability point of view.
  - Synchronized reconnection of island operated microgrid back to utility grid means that the voltage angle difference between utility grid and microgrid should be minimized before re-connection in order to prevent voltage disturbances in the MG;
- The small errors in voltage set points, can create the circulating currents which exceed the limits of the Micro source which causes voltage and/or reactive power oscillations. Likewise in island mode, the need to change power-operating points, for frequency generation to match load changes, can create problems and slight errors in frequency generation. Which makes these parameters (Voltage, frequency and power quality) main and must be considered and controlled to acceptable standards
- The unequal line impedances and DG output impedances significantly affect the accuracy of reactive power control during grid-connected operation mode and the reactive power sharing during islanding mode due to the unequal voltage drops[36].

### 2.1. Energy storage system

The Energy storage devices are one of the main critical components to rely on for successful operation of a microgrid that which provides the user with dispatch capability of the distributed resources (PV and wind etc.) also to be the care taker in balancing the power and energy demand with generation. It is easier to integrate into a dc system. The stored energy can then be used to provide electricity during periods of high demand. Energy storage devices take this responsibility in three necessary scenarios[24]:

- Insure the power balance in a microgrid despite load fluctuations and transients as DGs with their lower inertia lack the capability in fast responding to these disturbances;
- Provides ride-through capability when there are dynamic variations in intermittent energy sources and allows the DGs to operate as dispatchable units;
- Provides the initial energy requirement for a seamless transition between grid-connected to/from islanded operation of microgrids.

But its disadvantage is that the electrical energy needs to be stored in battery banks requiring more space and maintenance.

### 3. STRUCTURE OF DISTRIBUTED POWER GENERATION

DG is defined as, “Generation of electricity by facilities that are sufficiently smaller than central generating plants so as to allow interconnection at nearly any point in the power system” [43, 44]. The structure of distributed generation power system contains the input power source, different configurations are possible: photovoltaic, fuel cell, wind turbine, etc.; the converter which can be a single-stage converter (DC-AC converter) or a double stage converter (DC-DC and DC-AC converter). They have two separate operation modes, acting as a current source if they are connected to the grid and as a voltage source if they work autonomously [9]. An output filter (L, LC, LCL, and LCL with damping resistor) connected in series with the inverter improves harmonic performance at lower switching frequencies [45-50]. Recently, the LCL filter has been widely applied to the grid-interfaced inverters [45, 51]. The general structure having different input power sources is depicted in Fig. 3. The Distribution Generation (DG) unit can be connected to the utility grid through single Point of Common Coupling (PCC). It is responsible for generation of electricity and it has to be able to import/export energy to from/to the grid, control the active and reactive power flows and manage of the storage energy [19].

From Table I, the main task of the input controller is to extract the maximum power from the renewable energy sources and protect the input side converter while, the grid side controller must check the active and reactive power which is transferred from renewable energy systems to the grid.

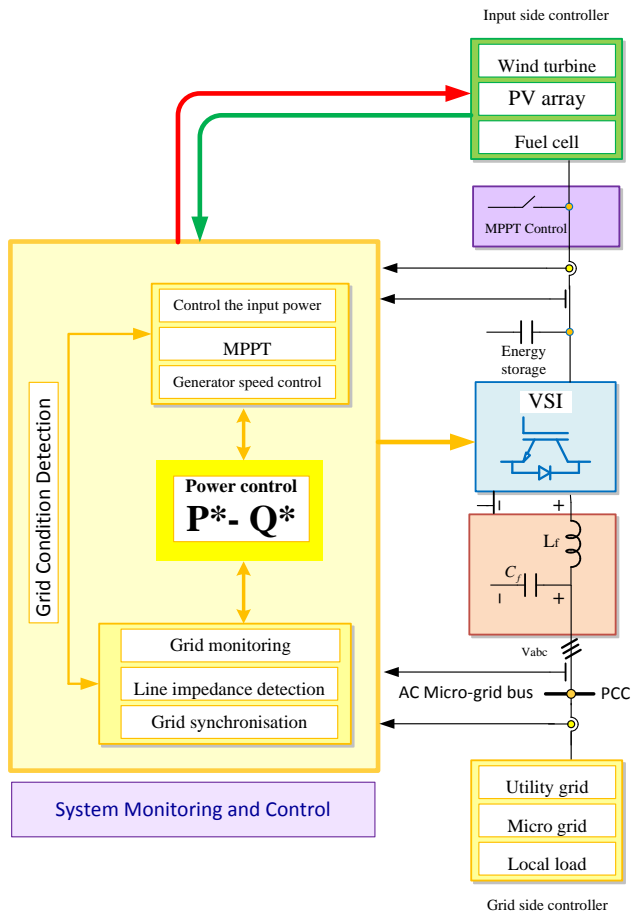

Fig. 3. General structure for distributed power system

TABLE I. PROPERTIES OF THE PART OF THE DPGS

Part of DPGS	Property
Input side controller	The main property to extract the maximum power from the input source:
	<ul style="list-style-type: none"> <li>a) Maximum power point tracking</li> <li>b) Generator speed control</li> </ul>
Grid side controller	Control of active power generated to the grid
	Control of reactive power transfer between the DPGS and the grid
	Control of dc-link voltage
	Grid synchronization
	Line impedance detection

#### 4. OVERVIEW AND DESIGN OF THE HIERARCHICAL CONTROL OF MICRO-GRID

Most current micro-grid implementations combine different distributed energy resources [18] (PV arrays, small wind turbines, or fuel cells) or storage devices (flywheels, superconductor inductors, or compressed air systems) [19, 52, 53]. However, at the present time it is necessary to conceive a supply microgrid which should be able to import/export energy from/to the grid (control of active and reactive power flow) [19], and flexible for standalone and grid-connected applications [11].

The hierarchical control for microgrids have been proposed recently in [4, 5, 8, 11, 18, 19, 54-61] for standardize the microgrid operation and functions. This hierarchical control can be divided into three levels of control namely primary, secondary and tertiary level, each of these levels has objectives and methods of controlling which are designed and manipulated by different controllers. [62, 63]. Fig 4 shows the schematic diagram of the hierarchical architecture of a microgrid using three levels of control: primary, secondary and tertiary.

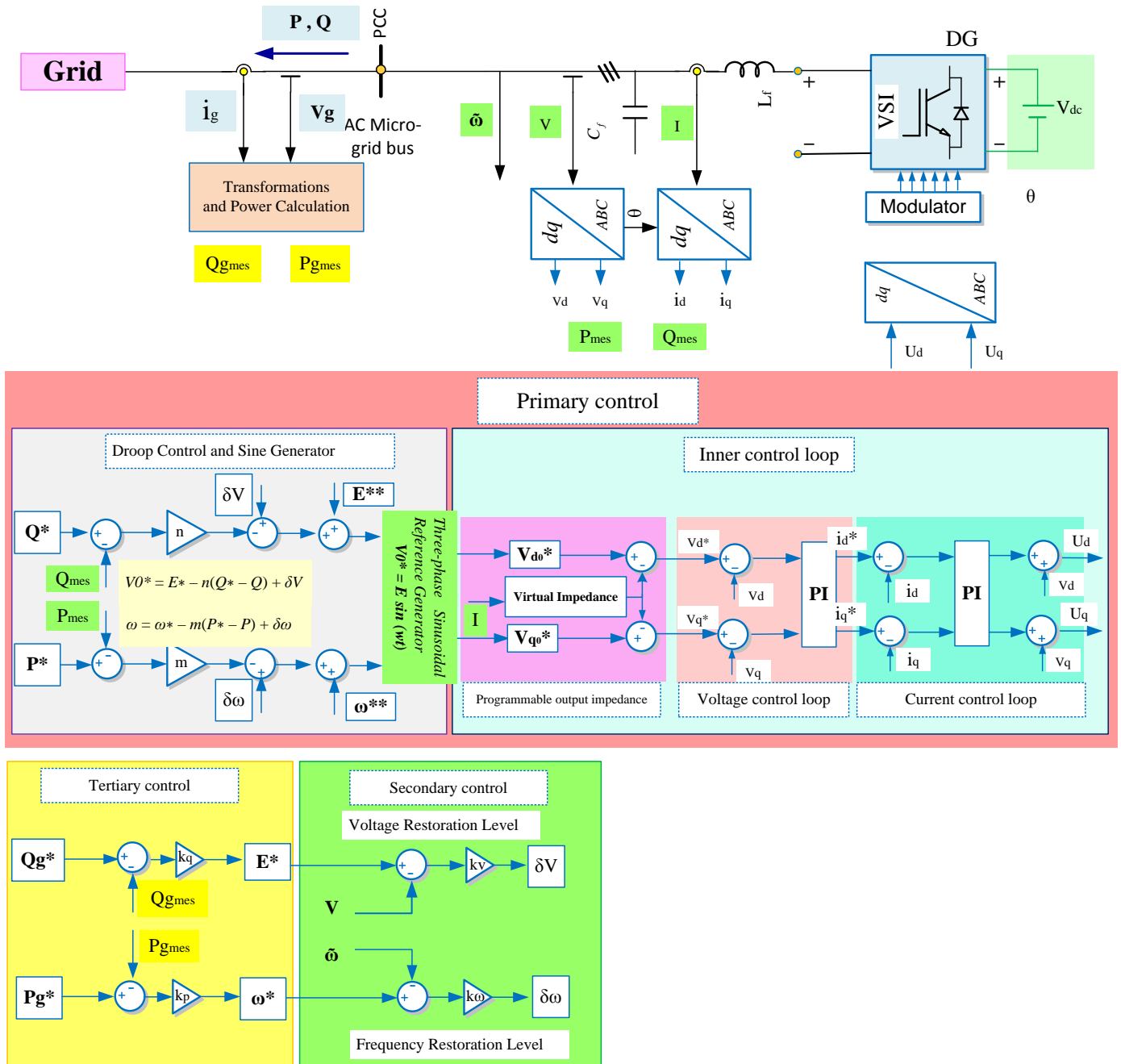

Fig.4. Hierarchical architecture of a microgrid

#### 4.1. Primary control (Droop control)

The primary controller is responsible for the reliability and improving the system performance and stability for the local voltage control; into adjusting at the same time the frequency and the magnitude of the output voltage to get the reference of inner current and voltage control loops, and for ensuring a proper power sharing (active and reactive power among DG units). Each inverter will have an external power loop based on droop control [60, 64], that allows each DG unit to operate autonomously. The primary control is based only on local measurements; communication is often avoided for reliability reasons,

The control of the parallel inverters in DG systems is based on [65-67]:

- the inner voltage and current regulation loops (feedback and feedforward, and linear and nonlinear control loops can be performed to regulate and supervises the inductor current or the capacitor current of the output filter to reach a fast dynamic response while maintaining the system stable)
- the intermediate virtual impedance loop (to emulate physical output impedance.)
- the outer active and reactive power sharing loops(whose function is to regulate the output voltage).

The droop control introduces the droops in the amplitude  $E$  and the frequency  $\omega$  of the inverter; they can be expressed as (Fig. 5):

$$\begin{cases} \omega = \omega^* - m(P - P^*) \\ E = E^* - n(Q - Q^*) \end{cases} \quad (1)$$

Where  $\omega^*$  and  $E^*$  are the angular frequency and the amplitude no load of the output voltage, respectively,  $m$  and  $n$  coefficients define the corresponding slopes for the frequency and amplitude, respectively.  $P^*$  and  $Q^*$  are the active and reactive power references, which are commonly set to zero when we connect DG units in parallel autonomously, forming the energetic island [4].

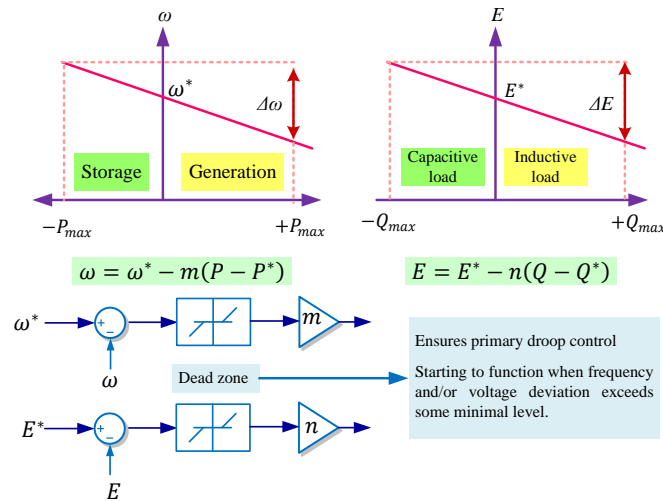

Figure 5: P/Q Droop characteristic when supplying capacitive or inductive loads

#### 4.2. Secondary control(Frequency and Voltage Restoration and Synchronization)

The secondary controller is responsible to restore the frequency and amplitude deviations produced by the virtual inertias and output virtual impedances (sacrificing by the primary control). Also, this control also takes on the function to synchronize the microgrid with the main grid before performing the interconnection, the transition from islanded to grid-connected mode. The secondary control must to measure the frequency and amplitude levels in the micro-grid  $\omega_g$  and  $E_g$  and the compares with the references  $\omega^*$  and  $E^*$ , and send the errors  $\Delta\omega$  and  $\Delta E$  to all the units to restore the output voltage [3, 11, 57, 68-78]. The phase between the grid and the micro-grid will be measured and send to all the modules to synchronize the micro-grid phase.

#### 4.3. Tertiary Control( P-Q Import and Export)

This level controls the power flow (the micro-grid imports/exports energy), the set points of the micro-grid inverters can be adjusted. The tertiary control level is responsible to regulating of the power flows (the import or export of energy) between the grid and the microgrid at the PCC and to provide load balancing by using an optimal power flow solver. Thus, the active and reactive power flows can be exported or imported independently [3, 4, 6, 8, 57, 58, 79, 80].



## 5. CLASSIFICATION OF OUTER CONTROL LOOPS FOR DPGS ACCORDING TO THEIR ROLE IN MICROGRIDS

The power inverter connected in parallel to the grid is controlled to exchange the power between the grid and the DPGS, this power are more or less proportional to power desirable, and the power inverter contribute to the formation of the grid voltage and frequency and are classified in three classes: grid-forming, grid-supporting and grid-feeding. These classes are discussed in this section.

### 5.1. Control of Grid-Forming Power Converters

The grid forming converters are power converters designed for autonomous operation, represented as AC voltage source ideal and a fixed frequency  $\omega^*$ , by balancing the power generators and loads. Fig.6 shows the basic circuit diagram for a power converter grid forming in three phases. The scheme of control consists of two control loops cascade into the  $dq$  referential frame, the outer loop is responsible for control the voltage, and the inner loop is responsible for the current control.

In the proposed control schema, the amplitude of the voltage at the  $PCC$  and current are measured and Transformed to dc values by applying the Park transformation  $dq$  and compared to reference values according to the control schema shown in Fig.6.

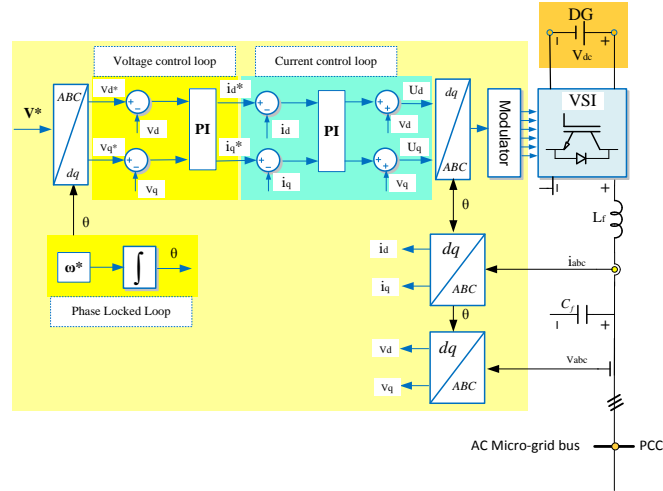

Fig. 6. Basic control scheme of a grid-forming voltage source inverter

With the implementation of the control scheme, it is possible to decouple the active component and reactive component to ensure the independent voltage regulation imposing the frequency reference. Based on the choice of reference  $dq$ , it is clear that the current  $i_d$  has control over the active component while the current  $i_q$  has control over the reactive component. Moreover, in the selection of reference, it is clear that the amplitude of  $V_q$  has a null value, while  $V_d$  the same amplitude as the reference voltage.

### 5.2. Control of Grid-Feeding Power Converters

The grid-feeding power converters are mainly designed to deliver (draw) a specified amount of active and reactive power to an energized grid. These components do not contribute to power balancing [81]. Grid-feeding power converters are controlled in current and can be represented as an ideal current source connected to the grid in parallel with presenting high parallel output impedance. These power converters are suitable to operate in parallel with other grid-feeding power converters in grid-connected mode. Actually, most of the power converters belonging to DG systems operate in grid-feeding mode, like in PV or wind power systems [23].

The scheme control of the grid-feeding power converter is depicted in Fig. 7, where  $P^*$  and  $Q^*$  represent the active and the reactive powers to be delivered, respectively. Control of the output voltage is no longer a purpose, and thus the control scheme comprises only the primary current control [81].

The grid-feeding should be perfectly synchronized with the ac voltage at the connection point, in order to regulate accurately the active and reactive power exchanged with the grid. This is why we must use phase locked loop. Based on the choice of reference  $dq$ , it is clear that the amplitude of  $V_q$  has a null value, while  $V_d$  is equal to the amplitude of the voltage, it is clear that the current  $i_d$  has control over the active component while the current  $i_q$  has control over the reactive component so it is clear that the desired direct  $i_d$  and quadrature  $i_q$  current components are easily derived from the active  $P^*$  and reactive  $Q^*$  power components by dividing them by the direct voltage component  $U_d$ . Grid-feeding power converters cannot operate in island mode if there is no grid-forming or grid-supporting power converter, or a local synchronous generator, setting the voltage amplitude and frequency of the ac microgrid [10].

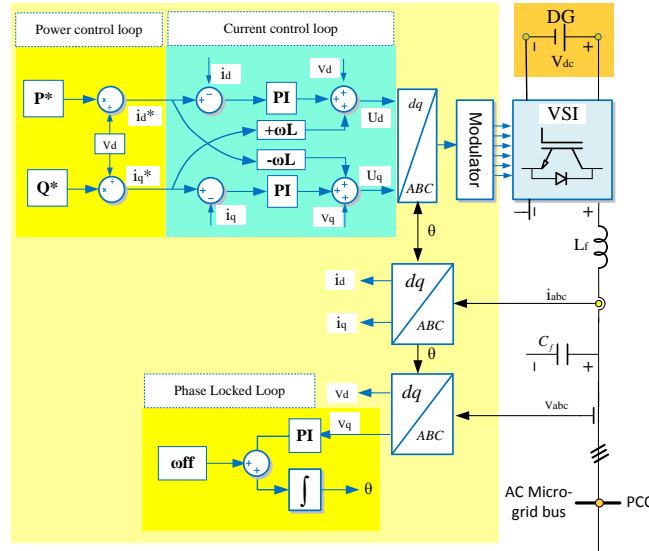

Fig. 7. Basic control scheme of a grid-feeding voltage source inverter

### 5.3. Control of Grid-Supporting Power Converters

Grid-supporting power converters are designed to the control of the AC grid voltage amplitude  $E^*$  (reactive power) and frequency  $\omega^*$  (active power) quality of either a stand-alone or interconnected grid allowing power sharing for to power balancing. They support a grid, either alone or with other grid-supporting inverters. There are two main types of power converters in the grid-supporting, those controlled as a voltage source with link impedance, or as a current source with parallel impedance. In grid-supporting inverters, the circulating currents between two grid-forming inverters paralleled are avoided by introducing artificial droop coefficients in the inverter frequency and voltage control, equivalent to the droop of the generator in the primary frequency control of synchronous generators in the utility grid [81]:

$$\begin{cases} f - f_0 = -k_p(P - P_0) \\ U - U_0 = -k_q(Q - Q_0) \end{cases} \quad (2)$$

#### 4.3.1. Grid supporting power converter operating as a voltage source.

The power converter is based about the control scheme of a grid-supporting inverter as shown in Fig. 8. There is controlled for emulating the behavior of an AC voltage source connected to the grid through link impedance which can be either a physical device connected between the VSI and the grid, or a virtual component, emulated within the current control loop.

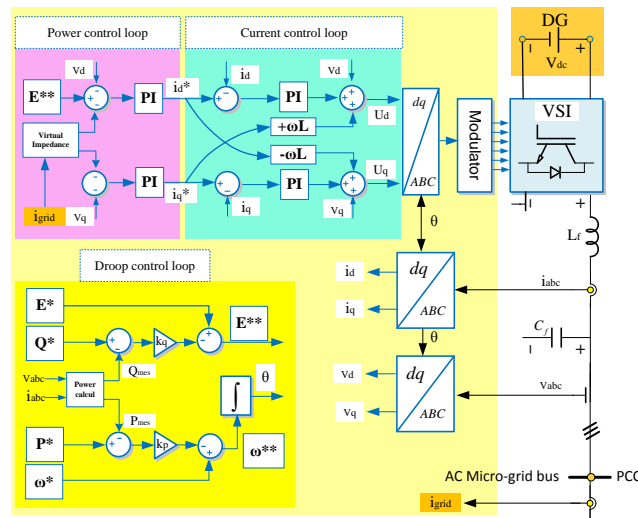

Fig. 8. Basic control scheme of a Grid-supporting power converter operating as a voltage source

The Grid supporting power converter operating as a voltage source allows regulating the amplitude and the frequency of the grid voltage in both grid-connected and island modes. The voltage amplitude and frequency are no longer fixed but obtained as a result of the droop equations as a function of active and reactive power components. In such a control scheme, active and reactive power  $P$  and  $Q$  delivered by the power converter are calculated by multiplying direct  $i_d$  and quadrature  $i_q$  current components by the direct  $U_d$  voltage grid component.

#### 4.3.2. Grid supporting power converter operating as a current source.

The power converter is based about the control scheme of a grid-feeding inverter as shown in Fig. 9. In which the main objective is contribute to regulate the voltage amplitude and frequency of both the ac grid and the micro grid and supply the load connected to the micro grid. The droop regulation techniques are implemented in grid-supporting power converters to regulate the exchange of active and reactive powers with the grid, in order to keep the grid voltage frequency and amplitude under control. The main idea to support the droop control comes from mimic the self-regulation capability of the synchronous generator in grid-connection mode, decreasing the delivered active power [10]. The scheme of Fig.8 remains stable as long as the droop gains are not too large, while the same holds for the inverse droop gains of Fig.7. It is noted that the scheme of Fig.8 is far more popular in literature than the one of Fig.9. Two reasons could be thought of for explaining this: the first reason is the analogy with the control of synchronous generators, the second reason being that droop characteristics for inverters were first implemented in UPS systems, traditionally being grid-forming. Starting from a grid-forming inverter, when adding the possibility of parallel operation, the most straightforward evolution is towards the scheme of Fig.6 [81].

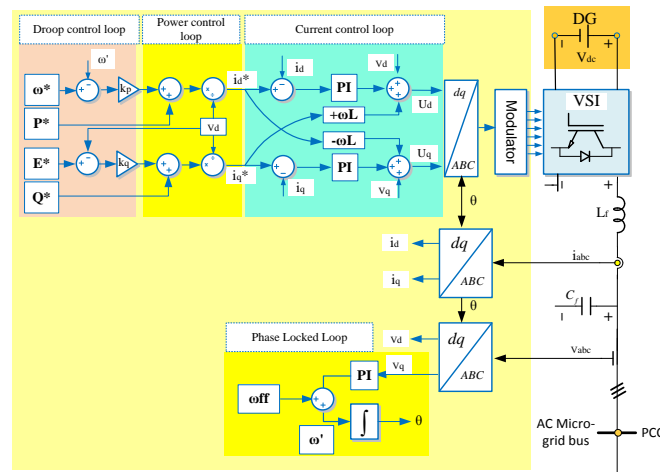

Fig. 9. Basic control scheme of a Grid-supporting power converter operating as a current source

From Table II, it is apparent that grid-forming and grid-feeding components are two extremes, whereas the grid-supporting component is in fact a generalization, having properties that lie between both extremes [81].

TABLE II. CLASSIFICATION OF GRID-CONNECTED COMPONENTS ACCORDING TO THEIR ELECTRICAL BEHAVIOUR AND THEIR CONTRIBUTION TO THE GRID

Contribution to the grid.	Classification of Grid-Connected		
	Grid-forming	Grid-feeding	Grid-supporting
Source type	Ideal voltage source	Ideal current source	Non-ideal voltage or current source
Control type	Constant frequency/voltage control	PQ control	Droop control
Combination	Series	Parallel	Parallel or series
Output impedance	$Z_d = 0$	$Z_d = \infty$	Finite, nonzero
Output frequency	Fixed frequency	Grid synchronized	Frequency droop
Application	Isolated	Grid-connected	Grid-connected or Isolated

## 6. OVERVIEW OF INNER CONTROL LOOPS FOR DPGS

Depending on the DPGS application, different controller's methods can be used for control of VSI. The control of a DPGS is mainly designed in accordance with the electrical grid conditions at the PCC. The purpose of all the different controllers is used to achieve satisfactory performance in terms steady state error requirements for utility connected converters and improve the disturbance rejection by rejecting utility voltage harmonics.

The control techniques vary from the very simple methods to complex analytical approaches; these controllers are briefly discussed here.

### 6.1. Classical Control PID

Classical PID control is the most technique employed for many decades for different applications, the advantage of this approach is its simplicity. Its theory is based on the complex-domain approach, which is applicable to linear time-invariant, single-input single-output (SISO) systems. Conventional PI regulators do not have proper performance for unbalanced systems. Several authors have used the classical PI controller in the literature. Wang *et al.* [82] have discusses the effect of the one-time step delay firstly, and proposes a step-by-step design method to choose the parameters of the PI-based current regulator and the capacitor-current feedback coefficient based on Jury stability criterion.

### 6.2. Proportional Resonant (PR)

Proportional resonant (PR) controllers are widely used in *abc* directly when the control variables are sinusoidal due to their ability to get rid of the steady state error and attenuation of individual harmonics [83-85]. PR is a good choice as inner voltage controller to show the desired performance. It theoretically introduces a high gain around the natural resonant frequency of  $\omega$ . In this structure a low order harmonics compensator can be easily implemented to improve the performance of the current controller without influencing its behavior [86]. It can be regarded as an AC regulator/integrator and is similar to an integrator whose infinite DC gain, forces the error to be zero [87]. Yaoqin *et al.* [46] proposes a proportional resonant (PR) controller under two-phase static coordinate designed to track the ac reference current as well as to avoid the strong coupling brought by the coordinate transformation. The virtual resistance based on the capacitance current is used to realize active damping, zero compensation is brought in to enhance the stability, the PR plus harmonic compensator (PR+HC) structure is adopted to restrain the distortion of the grid current.

### 6.3. Predictive Control

The predictive control is predicted at the beginning of each sample and the error is found. Then the control action is developed to minimize the forecast error so that the reference current can be tracked properly without any error. Seong *et al* [88]. have proposed predictive active damping method to minimize the resonant behavior during the grid connection, this method is added with the phase and gain compensations. Yang *et al.* [89] have proposed a predictive current control strategy in the inner loop and a fuzzy voltage control strategy in the outer loop that which can eliminate the steady-state phase error between the output and reference current, and compensate for the errors caused by sample delays and discretization computation, with a fixed switching frequency. Yohan *et al.* [90] have used predictive current control strategy based on predictive direct power control strategy en use a symmetrical 4x4 voltage vectors' sequence which selects two effective and two zero voltage vectors and determines concatenated voltage vectors' sequence. But the drawback of predictive current control is the mathematical based approach, which is sensitive to parameters changes. The parameter estimation is achieved by the least square method it improves an accuracy of control system [91]. Rezaei *et al.* [92] have proposed an improved predictive current control strategy for reducing the output current harmonic content of single-phase grid-connected inverters, based on nonlinear filter inductor model. Espi *et al.* [93] presents an adaptive robust predictive current control (RPCC) for grid-connected three-phase inverters. The error correction is achieved by means of an adaptive strategy that works in parallel with the deadbeat algorithm, therefore preserving the typical fast response of the predictive law. Jiabing and Zhu. [94] presents a dead-beat predictive direct power control (DPC) strategy and its improved voltage-vector sequences for reversible three-phase grid-connected voltage-source converters (VSCs).

### 6.4. Dead-Beat Control

A deadbeat controller (DB) is widely employed due to its high dynamic response in different applications, it is a very fast response method and suitable for the current controller. Timbus [95] and El-Saadany. [96] have used this control for voltage-source PWM converters in DPGS. They belong to the predictive control family, the controller is developed to minimize the forecast error (predict the effect of the control action) so that the reference current can be tracked properly without any error. In which utility current is predicted at the beginning of each sample and the current error is found [97]. Deadbeat control has a fast transient response and is widely employed for active power filters too. Mattavelli *et al.* [98, 99] have treated the robustness of this controller in where estimation of line voltage improves the robustness of the controller to the parameters mismatch. Mohamed and El-Saadany. [96] have proposed an improved dead beat controller using an adaptive self-tuning load model is presented. Although, these methods boost the robustness of dead beat controller in case of parameters mismatch, the solutions applied make the structure of the controller more complex [95].

### 6.5. Hysteresis Control

Hysteresis current control is a method for controlling a voltage source inverter to force the grid injected current follows a reference current [100]. It is a controller with non-linear controller loop with hysteresis comparators; an adaptive band of the controller has to be designed in order to obtain fixed switching frequency [20]. Moreover, several control strategies to provide flexible active and reactive power control during grid faults have been developed using the information of positive and negative sequence components. Malesani *et al.* [101] proposed a different methods and algorithms to obtain fixed switching frequency are presented. Depending on the method used, the complexity of the controller can be increased considerably [102]. Among advantages using a hysteresis control is predominantly the simplicity, robustness, independence of load parameters and good transient response [103]. There are two main disadvantages by using the hysteresis controller [104]. It does not have any fixed switching frequency and therefore a wide frequency spectrum and current ripple is relatively high and can theoretically reach twice the size of the band limit for the phase current hysteresis controller. Xunjiang and Qin. [105] have presented an adaptive hysteresis band control algorithm featuring dynamically modulate hysteresis band width. This algorithm show that grid-connected inverter can inject sinusoidal current into power grid and is in phase with power grid voltage with the result of unity of power factor.

### 6.6. LQG/LQR

The idea about optimal methods is based on the criteria function (or performance index) describing the behavior of the system where the minimum (or maximum) of the criteria function gives the control signal. When the system to be controlled is linear, all states are possible to measure and the criterion is a quadratic function of the states and control signal, the control system will be a linear quadratic (LQ) control system [97]. Alepuz *et al.* [106-110] have presented a approach simple and easy to implement for the control of the three level neutral-point-clamped (NPC) VSI converter based on the Linear Quadratic Regulator (LQR) and Gain-Scheduling control techniques, these control techniques work concurrently in the regulator, this allows the control of any state variables including state variables related to DC-link voltages. The LQR is a proportional regulator, adding an integral action cancels steady-state errors and the gain-scheduling control technique allows to extend the application of the controller from small-signal to large-signal operation. The advantage of this method is that information about the system is not lost and to obtain better voltage regulation and load sharing simultaneously. However, these state-feedback control schemes do not inherently include any means against external noise. For this purpose Kalman filter (observer) can be used, it has the property to minimize the variance of the estimation error, when zero-mean Gaussian random noise (i.e white noise) is considered [111]. The Kalman filter can be used to estimate the states of the system, when all states are not possible to measure and disturbances considerably affect the system, and the control system would be known as a linear quadratic Gaussian (LQG) control system [97].

### 6.7. Sliding mode controls

Sliding mode control (SMC) is recognized as robust controller ( can provide good performance against parameter variations) with a high stability in a wide range of operating conditions [97], it is a special version of on-off control and is a variable structure controller, however it suffers from chattering problem. The key idea is to apply strong control action when a system deviates from the desired behavior [112]. The adding a well-designed feed forward controller to the SMC improves the zero tracking speed as well as a non-overshoot transient performance. Sometimes, it is difficult to design a SMC to exhibit both suitable transient and zero steady state performance. In this case, a feedforward controller can be employed [113, 114]. Xiang *et al.* [112] have proposed a fixed switching frequency integral resonant SMC (IRSMC) based on pulse width modulation (PWM) under d-q rotate frame for three-phase grid-connected inverter with LCL- filter. The chattering problem of SMC is eliminated by adopting GAO's reaching law. In order to obtain an optimal trade-off between the elimination of chattering and the guarantee of performance of SMC, the parameters of SMC are optimized according to the ripple of the system output based on PWM. Moreover, an extra integral term of grid current error is introduced in sliding surface to eliminate the fundamental component of the tracking error. In order to suppress the grid current THD effectively, multiple resonant terms of the grid current error are added to the sliding function. Shang and Sun [115] have presents an improved means of direct power control (DPC) of grid-connected voltage-sourced inverters (GC-VSIs) when the network voltage is unbalanced. A new power compensation method is proposed for the SMC-based DPC during network unbalance to achieve three selective control targets, that is, obtaining sinusoidal and symmetrical grid current, removing reactive power ripples and cancelling active power ripples. Jiabing and Bin [116] proposed DPC strategy employs a nonlinear sliding mode control scheme to directly calculate the required converter voltage so as to eliminate the active and reactive power errors without involving any synchronous coordinate transformations. Besides, no extra current control loops are required, thereby simplifying the system design and enhancing the transient performance.

### 6.8. $H_\infty$ Controllers

The  $H_\infty$  methods are used in control theory to synthesis controllers that stabilizes the process not only for its nominal parameters values, but for the case in which the system parameters vary within certain limits also to guarantee the performance

with the worst-case disturbance. Order to satisfy certain performance requirements like: low overshoot, short settling time and also disturbance rejection. Its basic principle is to minimize the influence of the disturbances to outputs. T, Hornik and Zhong. [117] have proposed a current controller design based on  $H_\infty$  and repetitive control techniques for grid-connected inverters to reduce current total harmonic distortion (THD). The  $H_\infty$  current controller allows maintaining a balanced neutral point for a three-phase four-wire inverter and can eliminate the current flowing through the split capacitors. [118]. The current controller consists of an internal model and a stabilizing compensator, using the  $H_\infty$  control theory, to deal a very large number of harmonics simultaneously by injecting a clean sinusoidal current to the grid, even in the presence of nonlinear/unbalanced loads and/or grid-voltage distortions [119]. A voltage controller based on  $H_\infty$  and repetitive control techniques is proposed. A frequency adaptive mechanism is introduced to improve system performance and to cope with grid frequency variations. The repetitive control, based on the internal model principle, offers excellent performance for voltage tracking, as it can deal with a very large number of harmonics simultaneously [120]. The cascaded current-voltage control strategy proposed includes an inner voltage loop and an outer current loop, with both controllers designed using the  $H_\infty$  repetitive control strategy. Order to simultaneously improve the power quality of the inverter local load voltage and the current flowing within the micro grid. This leads to a very low THD in both the micro grid voltage and the grid current. It also enables seamless transfer of the operation mode from stand-alone to grid-connected or vice versa and also allows grid-connected inverters to inject balanced clean currents to the grid even when the local loads (if any) are unbalanced and/or nonlinear [121] [122].

### 6.9. Repetitive Controller (RC)

Repetitive feedback control (RC), has been derived from the concept of iterative learning control (ILC) and it can be used for control of utility converters with periodic reference signals or disturbances. The RC theory regarded as a simple learning control method, provides an alternative to eliminating periodic errors in dynamic systems, using the internal model principle [123]. In these controllers, error between the reference value and feedback utility connected current is used to generate a new reference for the next fundamental cycle [124] [125]. RC is mathematically equivalent to a parallel combination of an integral controller, many resonant controllers and a proportional controller [126] and accordingly good disturbance rejection can be achieved at these frequencies. To ensure stability, a low-pass filter needs to be incorporated within the repetitive controller to attenuate the high frequency resonant peaks of the controller gain (above the system's cross-over frequency), without significantly affecting the low frequency resonant peaks corresponding to significant grid harmonics that need to be rejected [124]. Liu *et al.* [125] proposed a control strategy To damp the harmonics, the inverter output current is regulated by PI controller and grid current is controlled by repetitive controller (RC) for three-phase grid-connected voltage source inverter (VSI) with LCL filter under d-q rotating frame. Chen *et al.* [127] have proposed an improved control scheme based on the T0/6 repetitive control for three-phase grid-connected inverters. The proposed scheme adopts T0/6 as the delay time in the positive-rotating and negative-rotating synchronous reference frames to suppress the  $6n \pm 1$  harmonics. A new auxiliary function based on the linear interpolation is proposed to maintain the ideal repetitive control performance when one-sixth of the ratio of the sampling frequency to the grid fundamental frequency is non-integer. Asbafkan *et al* [128] have presented a frequency adaptive repetitive controller (RC), which is based on the internal model principle (IMP). This controller is equivalent to a PR controller and infinite number of ideal resonant filters (harmonic compensators) with infinite gains. It is simple for the implementation and the ability to tune all the resonant frequencies simultaneously via the adaptation of the RC time delay parameter. But it can degrade significantly in the case of grid frequency variations while in the frequency adaptive scheme the high performance of the current controller is still preserved. Hornik and Zhong. [117-122] proposed a voltage controller is proposed and implemented for grid-connected inverters based on  $H_\infty$  and repetitive control techniques based on the internal model principle, which leads to a very low THD and improved tracking performance. Jiang and Peng. [129] use a high performance repetitive current controller for grid connected inverters based on a high-resonance-frequency LCL filter (deliberately selected higher than 40% of the inverter switching frequency). By properly selecting the current sensor LCL position and introducing an extra delay with a low pass filter on the feedback path, the system stability is obtained without the adoption of any extra damping techniques. High power factor ( $>0.99$ ) and very low THD (1.72%~3.72%) are guaranteed under both heavy and light load conditions. Loh *et al.* [130] have proposed a novel repetitive controller which can realize multi-harmonics rejection with a simple structure. The novel controller has been only verified in an L-filtered inverter. Guofei *et al.* [131] use the method, dual close-loop control with feed forward for limit the resonance peak of the LCL filter and brings high gain and rapid response; repetitive control can provide the system with the ability to attenuate grid harmonics and good robustness. Dong *et al.* [132] have proposed an improved repetitive control scheme with a special designed finite impulse response (FIR) filter. The FIR filter cascaded with a traditional delay function can approximate the ideal repetitive control function of any ratio. The proposed scheme varies the FIR filter according to varied grid frequency and maintains its resonant frequencies matching the grid fundamental and harmonic ones.

### 6.10. Neural Networks and Fuzzy Control Methods

Neural networks (NN) control method has been mostly used in current controllers because of its high robustness. Mohamed and El-Saadany [133] presents an adaptive discrete-time grid-voltage sensorless interfacing scheme for grid-connected distributed generation inverters, based on neural network identification. A reliable solution to the present nonlinear estimation problem is

presented by combining a neural network interfacing-parameters identifier (NNIPI) with a neural network grid-voltage estimator (NNGVE). The self-learning feature of the NN adaptation algorithm allows feasible and easy adaptation design at different grid disturbances and operating conditions. This provides improved robust control performance as compared to existing controllers, and integrates new control functions such as line-voltage sensorless current control and synchronization. The overall control system has a modest complexity and computational demand, which enabled real-time implementation using commercial grade digital signal processors [134].

Chao and Dagui [135] have studied to optimize the design of current controller: PI controller, fuzzy logic controller (FLC) and PI-FLC double-mode controller to reduce overshoots and improve the tracking error performance.

## 7. REVIEW OF SOFTWARE TOOLS

Several software tools have been deployed for the sizing, simulation, testing and optimization of hybrid systems, there are needed to use of several available natural resources, in this section we present different software and hardware used for study and integration of hybrid systems and microgrids

### 7.1. Optimization software tools

One of the most used software tools with this purpose is HOMER (Hybrid Optimization Model for Electric Renewables), originally developed at the National Renewable Energy Laboratory, USA, and enhanced and distributed by HOMER Energy [136]. It is a very famous software for hybrid systems because it has all the tools necessary for optimization, in order to determine the optimal architecture and control strategy, and further it is not too complicated [137]. The sensitivity analysis is also performed to obtain the optimal configuration of hybrid renewable energy based on different combinations of generating system [138]. It is able to optimize hybrid systems consisting of a photovoltaic generator, biomass, batteries, wind turbines, hydraulic turbines, AC generators, fuel cells, electrolyzers, hydrogen tanks, inverters (DC/AC converters), rectifiers (AC/DC converters), and combined heat and power (CHP). The loads can be AC, DC, and/or hydrogen-based loads, as well as thermal loads [139].

HYBRID2 [140] is a user friendly tool to perform detailed long term performance and economic analysis on a wide variety of hybrid power systems, it was developed by the Renewable Energy Research Laboratory (RERL) of the University of Massachusetts. Hybrid2 was designed to study a wide variety of hybrid power systems, e.g. multiple different types wind turbines, photovoltaic generators, multiple diesel generators, battery storage, four types of power conversion devices, and three types of electrical loads. Systems can be modeled in AC, DC or using both AC and DC. A variety of different control strategies and components like fuel cells or electrolyzers can be implemented in the software. The simulation is very precise, as it can define time intervals from ten minutes to one hour [139]. The most used software for this category is the famous Matlab/Simulink developed by Mathworks [141].

HOGA [142] (Hybrid Optimization by Genetic Algorithms) developed by the Electric Engineering Department of the University of Zaragoza (Spain) for the simulation and optimization of Hybrid Renewable Systems for generation of electrical energy (DC and/or AC) and/or hydrogen. Based on traditional genetic algorithms, HOGA has been improved with a robust selection operator and an intelligent crossover operator [143], which can be mono-objective (financial optimization) or multi-objective (minimization of CO<sub>2</sub> emissions or of unmet load, in case of energy not served). It allows optimizing hybrid generation systems integrating renewable energies (like photovoltaic panels and wind turbines), hydraulic turbines, AC generators, and storage systems based on batteries or hydrogen (fuel cells, electrolyzers, and hydrogen storage tanks), rectifiers, and inverters. The loads can be AC, DC, and/or hydrogen-loads or water pumping loads [144].

HYDROGEMS [145-147] is not a program, but a series of libraries developed at the Institute for Energy Technology (IFE, Norway). The libraries are used by TRNSYS and by Engineering Equation Solver (EES) software. HYDROGEMS-models can be used to analyze the performance of hydrogen energy systems down to one-minute time-steps. The libraries developed by HYDROGEMS model include the following components: wind energy conversion systems, photovoltaic systems, water electrolysis, fuel cells, hydrogen gas storage, metal hydride hydrogen storage, hydrogen compressor, secondary batteries (lead-acid), power conditioning equipment, and diesel engine generators, e.g. multi-fuels, including hydrogen and DC/AC converters.

RAPSim [148] (Renewable Alternativ Powersystems Simulation) is a software able to simulate grid-connected or standalone microgrids with solar, wind, or other renewable energy sources. This software is helpful for optimal placement of distributed generation units in a microgrid.

SOMES [149] (Simulation and Optimization Model for renewable Energy Systems) has been developed at Utrecht University (The Netherlands). It can simulate the performances of renewable energy systems that may contain renewable energy sources, such as PV arrays and wind turbines, a motor generator, a grid, battery storage, and several types of converters.

TRNSYS [150] (Transient Energy System Simulation Program) is an energy system simulation software initially developed to simulate thermal systems. Developed in Fortran and it is commercially available since 1975 by the University of Wisconsin and the University of Colorado (USA), continues to develop by the international collaboration of the United States, France, and

Germany. It is a hybrid system simulator, including photovoltaic panels, wind turbines, thermal solar systems, low energy buildings and HVAC systems, renewable energy systems, cogeneration, fuel cells, and other systems. The simulation is carried out with great precision, showing graphics with great detail and precision. TRNSYS has become a reference software for researchers and engineers around the world, but it does not carry out optimization.

### 7.2. Simulation platform and implementation in real-time

SPS/Simulink [151, 152] is the dominant, graphical interfaced, modeling and simulation tool, used in many engineering fields. Sim Power Systems (SPS) developed by Hydro-Quebec Research Center (IREQ) is a Simulink toolbox that provides multiple model components, all based on electromechanical and electromagnetic equations, for the simulation of power systems and machine drives.

RTDS Technologies is the industry standard for real time digital power system simulators [153]. The RTDS Simulator is designed specifically to simulate electrical power systems and to test physical equipment such as control and protection devices. The base components available in RTDS for study of microgrids are: real time network solution, sources, transformers, and distributed generators, such as wind turbines, photovoltaics, fuel cells and various other power sources can be represented by library components, while the corresponding VSC converters can be freely configured in small time step sub networks.

PSCAD™/EMTDC™ [154] is software allowing building, simulation, and modeling for renewable energy integration and power system, it offers an array of solutions in the following areas: System integration/impact studies (wind and solar), wind system custom equipment model development, FACTs and synchronous condenser based solutions for performance improvement, that which offers limitless possibilities in power system simulation. It includes a comprehensive library of system models.

OPAL-RT [155] is a leader in the development of PC/FPGA Based Real-Time Digital Simulators, Hardware-In-the-Loop (HIL) testing equipment and Rapid Control Prototyping (RCP) systems. RT-LAB, is software from OPAL-RT, fully integrated with MATLAB/Simulink®, is the open Real-Time Simulation software environment that has, through its flexibility and scalability, revolutionized the way Model-based Design is performed. These systems are used to design, test and optimize control and protection for different systems, like power grids, power electronics, and so forth.

Different researchers have used these tools in their research works on microgrids, for instance:

Ibarra Hernandez, F et al [156] have proposed the energy management and control for islanded microgrid using multi-agents formed by photovoltaic (PV) solar energy, batteries and resistive and rotating machines loads. The management and control of the PV system is performed in JADE (Java Agent DEvelopment Framework), while the microgrid model is simulated in RSCAD/RTDS (Real-Time Digital Simulator).

Yangkai L, et al [157] proposes a hardware in the loop simulation (HILS) system based on NI-PXI to test the microgrid operation and control. This microgrid includes a doubly-fed induction generator (DFIG), a battery energy storage system (BESS) and a desalination load.

Etemadi, A.H et al [158] presents the fundamental concepts of a generalized central power management system and a decentralized, robust control strategy for autonomous mode of operation of a microgrid that includes multiple distributed energy resource (DER) units. The digital time-domain simulation is studied in PSCAD/EMTDC platform and the performance of the control system is also verified based on hardware-in-the-loop (HIL) studies in the RTDS environment.

Farzinfar, M et al [159] present the real-time simulation of MGs and his implementation using discrete real-time simulator, Opal-RT platform. The model of the MG is first constructed in the MATLAB/Simulink environment and then is compiled to the Opal-RT to achieve parallel processing.

Lin-Yu L, [160] presents a consensus-based droop control method which will be developed for autonomous power management and load sharing. Dynamical simulations of a 6-DIC/14-bus micro-grid are performed under the real-time simulation environments OPAL-RT with detailed dynamical converter models.

## 8. DISCUSSIONS AND CONCLUSION

In this paper several control strategies that a distributed generation have been presented and compared in Table III. The aim of this comparative study is to find the advantages and disadvantages for each controller in term of robustness against parameters variation, rapidity, stability, performance, harmonic elimination and the nonlinearities of the system.



This paper summarizes the recent development in standards for interconnecting distributed power generators with electric power systems. DPGS are discussed in this paper. The structure of a DGPS system based on renewable energy, with the properties of these two important parts (input / grid side controller). The hierarchical control of intelligent microgrids was described in this paper showing the different operating modes (primary, secondary and tertiary) as a control hierarchical strategy. The contribution of the power inverter to the formation of the grid voltage and frequency is studied and each method is useful if it is chosen for an appropriate application in both grid-connected and islanded mode. In this research, a review of literature published on the various control strategies of DPGS is presented. We have found that with the advancement of power electronics, the researchers developed various control strategy so that harmonics are reduced as possible, secure the stability and power quality. These controllers are categorized as classical and advanced methods. Each method is used depending on the performance required. The future trends in microgrid technologies are toward the use of advanced decentralized control techniques, such as multi-agent systems where the general purpose of consensus algorithms is to allow a set of agents to reach an agreement on a quantity of interest by exchanging information through communication network[161-163], consensus algorithms, and so on. Furthermore, in the macroscopic level, multiple microgrids forming interconnected microgrids clusters and DC microgrids and low voltage DC distribution systems are becoming very important, because they present some advantages such as the reduction of conversion losses of inverters between DC output sources and loads are reduced, which increases enhancing the system efficiency; thus higher quality of power supply. The synchronization is no need and is not an issue for connection of DGs and ESSs to the bus and the main grid in DC MGs. There is no need for control of frequency and phase.

TABLE III. ADVANTAGES/DISADVANTAGES FOR EACH CONTROLLER

Methods	Advantages	Disadvantages
Classical Control PID	Simple control structures	When the operating conditions change, the performance degrades. For unbalanced systems, it does not ensure good performance. They are not the best solutions to compensate higher harmonic disturbances
Proportional Resonant (PR)	To show the desired performance, this method can be used with a robust inner current controller. Control of the harmonics.	Ensures a zero steady-state error by having significant gains, but in the vicinity of the controller's resonant frequencies
DeadBeat Controller (DB)	Ensures a fast response and suitable for the current controller and satisfied the requirement of very fast transient response with low THD, in the lower sampling frequency [164].	It has needed a precise model of the filter to reach the desired performance. Sensitive to the parametric variations of the controlled system and high THD for nonlinear loads [165].
Direct Power Control (DPC)	Simple controller with a very fast dynamic response	A non-constant switching frequency which makes it harder to : <ul style="list-style-type: none"> <li>• calculate to losses of the converter</li> <li>• design the switching noise filters.</li> </ul>
The Predictive Control	Possibility to include nonlinearities of the system [166]. Use to minimize switching frequency for high-power inverters and maintaining the current error within a specified bound[167]. Allows achieving more precise current control with minimum THD and harmonic noise.	It has needed a precise model of the filter to reach the desired performance.  This method needs a lot of calculations.

Methods	Advantages	Disadvantages
Hysteresis Current Control	These types of controllers are robust and simple, their implementation does not require complex circuits or processors, and they have fast transient response. Due to the interaction between the phases, the current error is not strictly limited to the value of the hysteresis band [166].	The major drawback of this controller is the frequency of switching variable with changes in parameters loads and operating conditions, which can cause resonance problems.  The switching losses restrict the application of hysteresis control to lower power levels [166].
Sliding Mode Control (SMC)	Exhibits reliable performance during transients. Shows an acceptable THD if it is designed well.	The problem of the Chattering Phenomenon in discrete implementation The difficulty of designing a controller having for both a good transient and zero steady state performance
Fuzzy Control Methods	Insensitive to parametric variations and operation points. Sophisticated technique, easy to design and implement a large-scale nonlinear system.	Slow control method.
Repetitive Controller (RC)	These controllers are implemented as harmonic compensator and current controller, they shows robust performance for periodic disturbances and ensures a zero steady-state error at all the harmonic frequencies.	Is not easy to stabilize for all unknown load disturbances and cannot obtain very fast response for fluctuating load Can cause a slow dynamic response and are applied only in static mode.
Neural Networks	These methods are trained in offline or on-line approaches and they are used in current controllers because of its high robustness.	The off-line method lacks a suitable performance.
$H_{\infty}$ Controllers	Readily applicable for Multi-Input Multi-Output (MIMO) systems coupled [168]. Take into account for plant uncertainties and disturbances same If the plant to be controlled has complex, or poorly modeled dynamics. [169]. A very low total harmonic distortion (THD) and improved performance contrary to other controllers. And improves the power quality. It ensures good performance even in the presence of nonlinear/unbalanced loads and/or grid-voltage distortion and reduces tracking error. Easy to implement in real applications [117-121, 170].	The high level of mathematical understanding The need for a very good model of the system [168].  Its relatively slow dynamics  The high order of the computer controllers.

## REFERENCES

- [1] G. Chicco and P. Mancarella, "Distributed multi-generation: A comprehensive view," *Renewable and Sustainable Energy Reviews*, vol. 13, pp. 535-551, 4// 2009.
- [2] A. Llaría, O. Curea, J. Jiménez, and H. Camblong, "Survey on microgrids: Unplanned islanding and related inverter control techniques," *Renewable Energy*, vol. 36, pp. 2052-2061, 8// 2011.
- [3] L. Xiaonan, J. M. Guerrero, S. Kai, J. C. Vasquez, R. Teodorescu, and H. Lipei, "Hierarchical Control of Parallel AC-DC Converter Interfaces for Hybrid Microgrids," *Smart Grid, IEEE Transactions on*, vol. 5, pp. 683-692, 2014.
- [4] J. C. Vasquez, J. M. Guerrero, J. Miret, M. Castilla, V. de, x00F, *et al.*, "Hierarchical Control of Intelligent Microgrids," *Industrial Electronics Magazine, IEEE*, vol. 4, pp. 23-29, 2010.
- [5] J. M. Guerrero, J. C. Vasquez, J. Matas, G. V. Luis, and M. Castilla, "Hierarchical Control of Droop-Controlled AC and DC Microgrids- A General Approach Toward Standardization," *Industrial Electronics, IEEE Transactions on*, vol. 58, pp. 158-172, 2011.

- [6] O. Palizban, K. Kauhaniemi, and J. M. Guerrero, "Microgrids in active network management—Part I: Hierarchical control, energy storage, virtual power plants, and market participation," *Renewable and Sustainable Energy Reviews*.
- [7] K. H. Sirviö, "Integrating low voltage distribution systems to distribution automation," Master, Faculty of technology, University Of Vaasa, Finland, 2012.
- [8] J. M. Guerrero, J. C. Vasquez, and R. Teodorescu, "Hierarchical control of droop-controlled DC and AC microgrids- a general approach towards standardization," in *Industrial Electronics, 2009. IECON '09. 35th Annual Conference of IEEE*, 2009, pp. 4305-4310.
- [9] J. M. Guerrero, J. C. Vasquez, J. Matas, J. L. Sosa, and L. G. de Vicuna, "Parallel operation of uninterruptible power supply systems in microgrids," in *Power Electronics and Applications, 2007 European Conference on*, 2007, pp. 1-9.
- [10] J. Rocabert, A. Luna, F. Blaabjerg, Rodri, x, and P. guez, "Control of Power Converters in AC Microgrids," *Power Electronics, IEEE Transactions on*, vol. 27, pp. 4734-4749, 2012.
- [11] J. M. Guerrero, M. Chandorkar, T. Lee, and P. C. Loh, "Advanced Control Architectures for Intelligent Microgrids-Part I: Decentralized and Hierarchical Control," *Industrial Electronics, IEEE Transactions on*, vol. 60, pp. 1254-1262, 2013.
- [12] J. C. Vasquez, J. M. Guerrero, M. Savaghebi, J. Eloy-Garcia, and R. Teodorescu, "Modeling, Analysis, and Design of Stationary-Reference-Frame Droop-Controlled Parallel Three-Phase Voltage Source Inverters," *Industrial Electronics, IEEE Transactions on*, vol. 60, pp. 1271-1280, 2013.
- [13] S. C. Bhattacharyya, "Review of alternative methodologies for analysing off-grid electricity supply," *Renewable and Sustainable Energy Reviews*, vol. 16, pp. 677-694, 1// 2012.
- [14] J. M. Guerrero, J. C. Vasquez, and R. Teodorescu, "Hierarchical control of droop-controlled DC and AC microgrids - a general approach towards standardization," in *Industrial Electronics, 2009. IECON '09. 35th Annual Conference of IEEE*, 2009, pp. 4305-4310.
- [15] J. M. Guerrero, N. Berbel, J. Matas, L. G. de Vicuna, and J. Miret, "Decentralized Control for Parallel Operation of Distributed Generation Inverters in Microgrids Using Resistive Output Impedance," in *IEEE Industrial Electronics, IECON 2006 - 32nd Annual Conference on*, 2006, pp. 5149-5154.
- [16] P. L. Villeneuve, "Concerns generated by islanding [electric power generation]," *Power and Energy Magazine, IEEE*, vol. 2, pp. 49-53, 2004.
- [17] M. C. Chandorkar, D. M. Divan, and R. Adapa, "Control of parallel connected inverters in standalone AC supply systems," *Industry Applications, IEEE Transactions on*, vol. 29, pp. 136-143, 1993.
- [18] H. Chaoyong, H. Xuehao, and H. Dong, "Hierarchical control techniques applied in micro-grid," in *Power System Technology (POWERCON), 2010 International Conference on*, 2010, pp. 1-5.
- [19] J. M. Guerrero, J. C. Vasquez, J. Matas, M. Castilla, and L. G. de Vicuna, "Control Strategy for Flexible Microgrid Based on Parallel Line-Interactive UPS Systems," *Industrial Electronics, IEEE Transactions on*, vol. 56, pp. 726-736, 2009.
- [20] F. Blaabjerg, R. Teodorescu, M. Liserre, and A. V. Timbus, "Overview of Control and Grid Synchronization for Distributed Power Generation Systems," *Industrial Electronics, IEEE Transactions on*, vol. 53, pp. 1398-1409, 2006.
- [21] J. J. Justo, F. Mwasilu, J. Lee, and J.-W. Jung, "AC-microgrids versus DC-microgrids with distributed energy resources: A review," *Renewable and Sustainable Energy Reviews*, vol. 24, pp. 387-405, 8// 2013.
- [22] P. Rodriguez, A. V. Timbus, R. Teodorescu, M. Liserre, and F. Blaabjerg, "Flexible Active Power Control of Distributed Power Generation Systems During Grid Faults," *Industrial Electronics, IEEE Transactions on*, vol. 54, pp. 2583-2592, 2007.
- [23] F. Blaabjerg, F. Iov, Z. Chen, and K. Ma, "Power electronics and controls for wind turbine systems," in *Energy Conference and Exhibition (EnergyCon), 2010 IEEE International*, 2010, pp. 333-344.
- [24] N. Lidula and A. Rajapakse, "Microgrids research: A review of experimental microgrids and test systems," *Renewable and Sustainable Energy Reviews*, vol. 15, pp. 186-202, 2011.
- [25] M. Barnes, "Real-world MicroGrid-an overview," in *IEEE International Conference on System of Systems Engineering, San Antonio, USA, 2007*, 2007.
- [26] F. Z. Peng, Y. W. Li, and L. M. Tolbert, "Control and protection of power electronics interfaced distributed generation systems in a customer-driven microgrid," in *Power & Energy Society General Meeting, 2009. PES'09. IEEE*, 2009, pp. 1-8.
- [27] A.-M. Borbely and J. F. Kreider, *Distributed generation: the power paradigm for the new millennium*: CRC press, 2001.
- [28] R. Lasseter, A. Akhil, C. Marnay, J. Stephens, J. Dagle, R. Guttromson, *et al.*, "The CERTS microgrid concept, white paper on integration of distributed energy resources," *California Energy Commission, Office of Power Technologies-US Department of Energy, LBNL-50829*, <http://certs.lbl.gov>, 2002.
- [29] R. Zamora and A. K. Srivastava, "Controls for microgrids with storage: Review, challenges, and research needs," *Renewable and Sustainable Energy Reviews*, vol. 14, pp. 2009-2018, 2010.

- [30] R. Lasseter, A. Akhil, C. Marnay, J. Stephens, J. Dagle, R. Guttromson, *et al.*, "The CERTS microgrid concept," *White paper for Transmission Reliability Program, Office of Power Technologies, US Department of Energy*, 2002.
- [31] R. H. Lasseter, "Smart distribution: Coupled microgrids," *Proceedings of the IEEE*, vol. 99, pp. 1074-1082, 2011.
- [32] N. Hatzigaryriou, N. Jenkins, G. Strbac, J. P. Lopes, J. Ruela, A. Engler, *et al.*, "Microgrids—large scale integration of microgeneration to low voltage grids," *CIGRE C6-309*, 2006.
- [33] L. Tao and C. Schwaegerl, "Advanced architectures and control concepts for more microgrids," EC Project, Tech. Rep. SES6-0198642009.
- [34] J. Sarkar and P. Yade, "Structuring DC Micro-Grid for Integrating Renewable Energy in a DC Load Dominant Electrical Environment."
- [35] R. H. Lasseter; and P. Piagi, "Control and design of microgrid components," University of Wisconsin-Madison, PSERC Publication 06-03 Jan 2006.
- [36] Y. W. Li and C.-N. Kao, "An accurate power control strategy for power-electronics-interfaced distributed generation units operating in a low-voltage multibus microgrid," *Power Electronics, IEEE Transactions on*, vol. 24, pp. 2977-2988, 2009.
- [37] H. Laaksonen and K. Kauhaniemi, "Synchronized re-connection of island operated LV microgrid back to utility grid," in *Innovative Smart Grid Technologies Conference Europe (ISGT Europe), 2010 IEEE PES*, 2010, pp. 1-8.
- [38] H. Jiayi, J. Chuanwen, and X. Rong, "A review on distributed energy resources and MicroGrid," *Renewable and Sustainable Energy Reviews*, vol. 12, pp. 2472-2483, 2008.
- [39] R. H. Lasseter, "Microgrids and distributed generation," *Journal of Energy Engineering*, vol. 133, pp. 144-149, 2007.
- [40] R. H. Lasseter, "Microgrids and distributed generation," *Intelligent Automation & Soft Computing*, vol. 16, pp. 225-234, 2010.
- [41] R. H. Lasseter and P. Paigi, "Microgrid: a conceptual solution," in *Power Electronics Specialists Conference, 2004. PESC 04. 2004 IEEE 35th Annual*, 2004, pp. 4285-4290.
- [42] H. Laaksonen and K. Kauhaniemi, "Stability of Microgrid with Different Configurations after Islanding Due to Fault in the Utility Grid," *International Review of Electrical Engineering*, vol. 3, 2008.
- [43] M. S. Mahmoud, S. Azher Hussain, and M. A. Abido, "Modeling and control of microgrid: An overview," *Journal of the Franklin Institute*, vol. 351, pp. 2822-2859, 5// 2014.
- [44] G. Pepermans, J. Driesen, D. Haeseldonckx, R. Belmans, and W. D'haeseleer, "Distributed generation: definition, benefits and issues," *Energy Policy*, vol. 33, pp. 787-798, 4// 2005.
- [45] Z. Zhixiang, W. Zheng, and C. Ming, "Modeling, Analysis, and Design of Multifunction Grid-Interfaced Inverters With Output LCL Filter," *Power Electronics, IEEE Transactions on*, vol. 29, pp. 3830-3839, 2014.
- [46] J. Yaoqin, Z. Jiqian, and F. Xiaowei, "Direct Grid Current Control of LCL-Filtered Grid-Connected Inverter Mitigating Grid Voltage Disturbance," *Power Electronics, IEEE Transactions on*, vol. 29, pp. 1532-1541, 2014.
- [47] X. Jinming, X. Shaojun, and T. Ting, "Active Damping-Based Control for Grid-Connected LCL Filtered Inverter With Injected Grid Current Feedback Only," *Industrial Electronics, IEEE Transactions on*, vol. 61, pp. 4746-4758, 2014.
- [48] M. Hamzeh, Y. Karimi, E. Asadi, and H. Oraee, "Design and implementation of a single phase grid-connected PV inverter with a new active damping strategy," in *Power Electronics, Drive Systems and Technologies Conference (PEDSTC), 2014 5th*, 2014, pp. 72-77.
- [49] B. Chenlei, R. Xinbo, W. Xuehua, L. Weiwei, P. Donghua, and W. Kailei, "Step-by-Step Controller Design for LCL-Type Grid-Connected Inverter with Capacitor Current-Feedback Active-Damping," *Power Electronics, IEEE Transactions on*, vol. 29, pp. 1239-1253, 2014.
- [50] W. Weimin, H. Yuanbin, T. Tianhao, and F. Blaabjerg, "A New Design Method for the Passive Damped LCL and LLCL Filter-Based Single-Phase Grid-Tied Inverter," *Industrial Electronics, IEEE Transactions on*, vol. 60, pp. 4339-4350, 2013.
- [51] J. L. Agorreta, M. Borrega, Lo, x, J. pez, and L. Marroyo, "Modeling and Control of N Paralleled Grid-Connected Inverters With LCL Filter Coupled Due to Grid Impedance in PV Plants," *Power Electronics, IEEE Transactions on*, vol. 26, pp. 770-785, 2011.
- [52] D. Georgakis, S. Papathanassiou, N. Hatzigaryriou, A. Engler, and C. Hardt, "Operation of a prototype microgrid system based on micro-sources equipped with fast-acting power electronics interfaces," in *Power Electronics Specialists Conference, 2004. PESC 04. 2004 IEEE 35th Annual*, 2004, pp. 2521-2526 Vol.4.
- [53] A. L. Dimeas and N. D. Hatzigaryriou, "Operation of a Multiagent System for Microgrid Control," *Power Systems, IEEE Transactions on*, vol. 20, pp. 1447-1455, 2005.
- [54] T. L. Vandoorn, J. C. Vasquez, J. De Kooning, J. M. Guerrero, and L. Vandevelde, "Microgrids: Hierarchical Control and an Overview of the Control and Reserve Management Strategies," *Industrial Electronics Magazine, IEEE*, vol. 7, pp. 42-55, 2013.

- [55] H. R. Chamorro and N. L. Diaz, "Hierarchical power flow control in low voltage microgrids," in *North American Power Symposium (NAPS), 2013*, 2013, pp. 1-5.
- [56] A. Micallef, M. Apap, C. Spiteri-Staines, J. M. Guerrero, and J. C. Vasquez, "Reactive Power Sharing and Voltage Harmonic Distortion Compensation of Droop Controlled Single Phase Islanded Microgrids," *Smart Grid, IEEE Transactions on*, vol. 5, pp. 1149-1158, 2014.
- [57] M. Savaghebi, J. M. Guerrero, A. Jalilian, J. C. Vasquez, and L. Tzung-Lin, "Hierarchical control scheme for voltage Harmonics Compensation in an islanded droop-controlled microgrid," in *Power Electronics and Drive Systems (PEDS), 2011 IEEE Ninth International Conference on*, 2011, pp. 89-94.
- [58] M. Savaghebi, J. M. Guerrero, A. Jalilian, and J. C. Vasquez, "Hierarchical control scheme for voltage unbalance compensation in islanded microgrids," in *IECON 2011 - 37th Annual Conference on IEEE Industrial Electronics Society*, 2011, pp. 3158-3163.
- [59] O. Palizban, K. Kauhaniemi, and J. M. Guerrero, "Microgrids in active network management—Part I: Hierarchical control, energy storage, virtual power plants, and market participation," *Renewable and Sustainable Energy Reviews*, vol. 36, pp. 428-439, 8// 2014.
- [60] J. C. Vasquez, R. A. Mastromauro, J. M. Guerrero, and M. Liserre, "Voltage Support Provided by a Droop-Controlled Multifunctional Inverter," *Industrial Electronics, IEEE Transactions on*, vol. 56, pp. 4510-4519, 2009.
- [61] A. Bidram and A. Davoudi, "Hierarchical Structure of Microgrids Control System," *Smart Grid, IEEE Transactions on*, vol. 3, pp. 1963-1976, 2012.
- [62] J. A. Peas Lopes, C. L. Moreira, and A. G. Madureira, "Defining control strategies for analysing microgrids islanded operation," in *Power Tech, 2005 IEEE Russia*, 2005, pp. 1-7.
- [63] J. M. Guerrero, N. Berbel, J. Matas, J. L. Sosa, J. Cruz, and A. Alentorn, "Decentralized control for parallel operation of distributed generation inverters using resistive output impedance," in *Power Electronics and Applications, 2005 European Conference on*, 2005, pp. 10 pp.-P.10.
- [64] E. A. A. Coelho, P. C. Cortizo, and P. F. D. Garcia, "Small-signal stability for parallel-connected inverters in stand-alone AC supply systems," *Industry Applications, IEEE Transactions on*, vol. 38, pp. 533-542, 2002.
- [65] W. Tsai-Fu, C. Yu-Kai, and H. Yong-Heh, "3C strategy for inverters in parallel operation achieving an equal current distribution," *Industrial Electronics, IEEE Transactions on*, vol. 47, pp. 273-281, 2000.
- [66] W. Hongying, L. Dong, Z. Dehua, Y. Kaiwei, and Z. Jinfa, "A current-mode control technique with instantaneous inductor-current feedback for UPS inverters," in *Applied Power Electronics Conference and Exposition, 1999. APEC '99. Fourteenth Annual*, 1999, pp. 951-957 vol.2.
- [67] Q. Shafiee, J. M. Guerrero, and J. C. Vasquez, "Distributed Secondary Control for Islanded Microgrids&#x2014;A Novel Approach," *Power Electronics, IEEE Transactions on*, vol. 29, pp. 1018-1031, 2014.
- [68] M. Savaghebi, J. C. Vasquez, A. Jalilian, and J. M. Guerrero, "Secondary control for compensation of voltage harmonics and unbalance in microgrids," in *Power Electronics for Distributed Generation Systems (PEDG), 2012 3rd IEEE International Symposium on*, 2012, pp. 46-53.
- [69] M. Savaghebi, A. Jalilian, J. C. Vasquez, and J. M. Guerrero, "Secondary Control for Voltage Quality Enhancement in Microgrids," *Smart Grid, IEEE Transactions on*, vol. 3, pp. 1893-1902, 2012.
- [70] M. Savaghebi, A. Jalilian, J. C. Vasquez, and J. M. Guerrero, "Secondary Control Scheme for Voltage Unbalance Compensation in an Islanded Droop-Controlled Microgrid," *Smart Grid, IEEE Transactions on*, vol. 3, pp. 797-807, 2012.
- [71] W. Xiongfei, J. M. Guerrero, F. Blaabjerg, and C. Zhe, "Secondary voltage control for harmonics suppression in islanded microgrids," in *Power and Energy Society General Meeting, 2011 IEEE*, 2011, pp. 1-8.
- [72] M. Savaghebi, J. M. Guerrero, A. Jalilian, and J. C. Vasquez, "Secondary control for voltage unbalance compensation in an islanded microgrid," in *Smart Grid Communications (SmartGridComm), 2011 IEEE International Conference on*, 2011, pp. 499-504.
- [73] P. Jung-Wook and R. G. Harley, "Secondary control for a series reactive compensator based on a voltage-source PWM inverter," *Power Electronics Letters, IEEE*, vol. 2, pp. 117-120, 2004.
- [74] Q. Shafiee, C. Stefanovic, T. Dragicevic, P. Popovski, J. C. Vasquez, and J. M. Guerrero, "Robust Networked Control Scheme for Distributed Secondary Control of Islanded Microgrids," *Industrial Electronics, IEEE Transactions on*, vol. 61, pp. 5363-5374, 2014.
- [75] A. Bidram, A. Davoudi, F. L. Lewis, and J. M. Guerrero, "Distributed Cooperative Secondary Control of Microgrids Using Feedback Linearization," *Power Systems, IEEE Transactions on*, vol. 28, pp. 3462-3470, 2013.
- [76] Q. Shafiee, J. C. Vasquez, and J. M. Guerrero, "Distributed secondary control for islanded MicroGrids - A networked control systems approach," in *IECON 2012 - 38th Annual Conference on IEEE Industrial Electronics Society*, 2012, pp. 5637-5642.

- [77] A. Micallef, M. Apap, C. S. Staines, and J. M. Guerrero Zapata, "Secondary control for reactive power sharing and voltage amplitude restoration in droop-controlled islanded microgrids," in *Power Electronics for Distributed Generation Systems (PEDG), 2012 3rd IEEE International Symposium on*, 2012, pp. 492-498.
- [78] J. W. Simpson-Porco, F. Dorfler, F. Bullo, Q. Shafiee, and J. M. Guerrero, "Stability, power sharing, & distributed secondary control in droop-controlled microgrids," in *Smart Grid Communications (SmartGridComm), 2013 IEEE International Conference on*, 2013, pp. 672-677.
- [79] M. Lexuan, J. M. Guerrero, J. C. Vasquez, T. Fen, and M. Savaghebi, "Tertiary control for optimal unbalance compensation in islanded microgrids," in *Multi-Conference on Systems, Signals & Devices (SSD), 2014 11th International*, 2014, pp. 1-6.
- [80] J. C. Vasquez, J. M. Guerrero, A. Luna, P. Rodriguez, and R. Teodorescu, "Adaptive Droop Control Applied to Voltage-Source Inverters Operating in Grid-Connected and Islanded Modes," *Industrial Electronics, IEEE Transactions on*, vol. 56, pp. 4088-4096, 2009.
- [81] K. D. BRABANDERE, "Voltage and frequency droop control in low voltage grids by distributed generators with inverter front-end," Phd, Faculteit Ingenieurswetenschappen, Departement Elektrotechniek Afdeling Elektrische Energie En Computerarchitecturen, Katholieke Universiteit Leuven, België, 2006.
- [82] W. Xuehua, R. Xinbo, B. Chenlei, P. Donghua, and X. Lin, "Design of the PI regulator and feedback coefficient of capacitor current for grid-connected inverter with an LCL filter in discrete-time domain," in *Energy Conversion Congress and Exposition (ECCE), 2012 IEEE*, 2012, pp. 1657-1662.
- [83] J. G. Hwang, P. W. Lehn, and M. Winkelnkemper, "A Generalized Class of Stationary Frame-Current Controllers for Grid-Connected AC-DC Converters," *Power Delivery, IEEE Transactions on*, vol. 25, pp. 2742-2751, 2010.
- [84] S. Guoqiao, Z. Xuancai, Z. Jun, and X. Dehong, "A New Feedback Method for PR Current Control of LCL-Filter-Based Grid-Connected Inverter," *Industrial Electronics, IEEE Transactions on*, vol. 57, pp. 2033-2041, 2010.
- [85] M. Liserre, R. Teodorescu, and F. Blaabjerg, "Multiple harmonics control for three-phase grid converter systems with the use of PI-RES current controller in a rotating frame," *Power Electronics, IEEE Transactions on*, vol. 21, pp. 836-841, 2006.
- [86] A. V. Timbus, R. Teodorescu, F. Blaabjerg, M. Liserre, and P. Rodriguez, "Linear and Nonlinear Control of Distributed Power Generation Systems," in *Industry Applications Conference, 2006. 41st IAS Annual Meeting. Conference Record of the 2006 IEEE*, 2006, pp. 1015-1023.
- [87] R. Teodorescu, F. Blaabjerg, M. Liserre, and P. C. Loh, "Proportional-resonant controllers and filters for grid-connected voltage-source converters," *Electric Power Applications, IEE Proceedings*, vol. 153, pp. 750-762, 2006.
- [88] H.-S. Heo, G.-H. Choe, and H.-S. Mok, "Robust predictive current control of a grid-connected inverter with harmonics compensation," in *Applied Power Electronics Conference and Exposition (APEC), 2013 Twenty-Eighth Annual IEEE*, 2013, pp. 2212-2217.
- [89] Y. Bo, W. Jiande, L. Xiaodong, and H. Xiangning, "An improved DSP-based control strategy with predictive current control and fuzzy voltage control for grid-connected voltage source inverters," in *Industrial Electronics, 2008. IECON 2008. 34th Annual Conference of IEEE*, 2008, pp. 2296-2300.
- [90] B. Yohan, L. Kui-Jun, and H. Dong-Seok, "Improved Predictive Current Control for Grid Connected Inverter Applications with Parameter Estimation," in *Industry Applications Society Annual Meeting, 2009. IAS 2009. IEEE*, 2009, pp. 1-6.
- [91] B. Yohan, L. Kui-Jun, and H. Dong-Seok, "Improved predictive current control by parameter estimation in grid connected inverter applications," in *Power Electronics and Motion Control Conference, 2009. IPESC '09. IEEE 6th International*, 2009, pp. 1535-1538.
- [92] M. A. Rezaei, S. Farhangi, and G. Farivar, "An improved predictive current control method for grid-connected inverters," in *Power Electronic & Drive Systems & Technologies Conference (PEDSTC), 2010 1st*, 2010, pp. 445-449.
- [93] J. M. Espi, J. Castello, Garci, x, R. a-Gil, G. Garcera, *et al.*, "An Adaptive Robust Predictive Current Control for Three-Phase Grid-Connected Inverters," *Industrial Electronics, IEEE Transactions on*, vol. 58, pp. 3537-3546, 2011.
- [94] H. Jiabing and Z. Q. Zhu, "Improved Voltage-Vector Sequences on Dead-Beat Predictive Direct Power Control of Reversible Three-Phase Grid-Connected Voltage-Source Converters," *Power Electronics, IEEE Transactions on*, vol. 28, pp. 254-267, 2013.
- [95] A. Timbus, "Grid Monitoring and Advanced Control of Distributed Power Generation Systems," Doctor of Philosophy in Electrical Engineering, Institute of Energy Technology. Faculty of Engineering, Science & Medicine at Aalborg University, Aalborg University, Denmark, May, 2007.
- [96] Y. A. R. I. Mohamed and E. F. El-Saadany, "An Improved Deadbeat Current Control Scheme With a Novel Adaptive Self-Tuning Load Model for a Three-Phase PWM Voltage-Source Inverter," *Industrial Electronics, IEEE Transactions on*, vol. 54, pp. 747-759, 2007.

- [97] M. Jamil, "Repetitive Current Control of Two-Level and Interleaved Three-Phase PWM Utility Connected Converters," doctor of Philosophy, Faculty of Engineering and the Environment, university of Southampton, 2012.
- [98] P. Mattavelli, G. Spiazzi, and P. Tenti, "Predictive digital control of power factor preregulators with input voltage estimation using disturbance observers," *Power Electronics, IEEE Transactions on*, vol. 20, pp. 140-147, 2005.
- [99] L. Malesani, P. Mattavelli, and S. Buso, "Robust dead-beat current control for PWM rectifiers and active filters," *Industry Applications, IEEE Transactions on*, vol. 35, pp. 613-620, 1999.
- [100] A. Z. A. Mojgan Hojabri, Arash Toudeshki and Mohammadsoroush Soheilrad, "An Overview on Current Control Techniques for Grid Connected Renewable Energy Systems," in *2012 2nd International Conference on Power and Energy Systems (ICPES 2012)*, Singapore, 2012, pp. 119-126.
- [101] L. Malesani, P. Mattavelli, and P. Tomasin, "Improved constant-frequency hysteresis current control of VSI inverters with simple feedforward bandwidth prediction," *Industry Applications, IEEE Transactions on*, vol. 33, pp. 1194-1202, 1997.
- [102] B. K. Bose, "An adaptive hysteresis-band current control technique of a voltage-fed PWM inverter for machine drive system," *Industrial Electronics, IEEE Transactions on*, vol. 37, pp. 402-408, 1990.
- [103] M. P. Kazmierkowski and L. Malesani, "Current control techniques for three-phase voltage-source PWM converters: a survey," *Industrial Electronics, IEEE Transactions on*, vol. 45, pp. 691-703, 1998.
- [104] T. Midtsund, "Control of Power Electronic Converters in Distributed Power Generation Systems (Evaluation of Current Control Structures for Voltage Source Converters operating under Weak Grid Conditions)," Master of Science in Energy and Environment, Department of Electric Power Engineering, Norwegian University of Science and Technology, Norway, 2010.
- [105] D. Xunjiang and C. Qin, "The research of photovoltaic grid-connected inverter based on adaptive current hysteresis band control scheme," in *Sustainable Power Generation and Supply, 2009. SUPERGEN '09. International Conference on*, 2009, pp. 1-8.
- [106] S. Alepuz, A. Gilabert, E. Arguelles, J. Bordonau, and J. Peracaula, "A new approach for the connection of a three-level inverter to the power grid for applications in solar energy conversion," in *IECON 02 [Industrial Electronics Society, IEEE 2002 28th Annual Conference of the]*, 2002, pp. 3285-3290 vol.4.
- [107] S. Alepuz, J. Bordonau, and J. Peracaula, "A novel control approach of three-level VSIs using a LQR-based gain-scheduling technique," in *Power Electronics Specialist Conference, 2000. PESC 00. 2000 IEEE 31st Annual*, 2000, pp. 743-748 vol.2.
- [108] S. Alepuz, J. Salaet, A. Gilabert, J. Bordonau, and J. Peracaula, "Control of three-level VSIs with a LQR-based gain-scheduling technique applied to DC-link neutral voltage and power regulation," in *IECON 02 [Industrial Electronics Society, IEEE 2002 28th Annual Conference of the]*, 2002, pp. 914-919 vol.2.
- [109] S. Alepuz, J. Salaet, A. Gilabert, J. Bordonau, and J. Peracaula, "Optimal regulator with integral action and gain-scheduling for the comprehensive control of three-level NPC VSI," in *Power Electronics Specialist Conference, 2003. PESC '03. 2003 IEEE 34th Annual*, 2003, pp. 1420-1425 vol.3.
- [110] S. Alepuz, S. Busquets-Monge, J. Bordonau, J. Gago, D. Gonzalez, and J. Balcells, "Interfacing Renewable Energy Sources to the Utility Grid Using a Three-Level Inverter," *Industrial Electronics, IEEE Transactions on*, vol. 53, pp. 1504-1511, 2006.
- [111] P. Peltoniemi, P. Nuutinen, M. Niemela, and J. Pyrhonen, "LQG-based voltage control of the single-phase inverter for noisy environment," in *Power Electronics and Applications, 2009. EPE '09. 13th European Conference on*, 2009, pp. 1-10.
- [112] H. Xiang, Y. Xu, X. Ruiliang, H. Lang, L. Tao, and L. Yang, "A fixed switching frequency integral resonant sliding mode controller for three-phase grid-connected photovoltaic inverter with LCL-filter," in *ECCE Asia Downunder (ECCE Asia), 2013 IEEE*, 2013, pp. 793-798.
- [113] S. L. Jung and T. Ying-Yu, "Discrete sliding-mode control of a PWM inverter for sinusoidal output waveform synthesis with optimal sliding curve," *Power Electronics, IEEE Transactions on*, vol. 11, pp. 567-577, 1996.
- [114] M. A. Sofla and R. King, "Control method for multi-microgrid systems in smart grid environment—Stability, optimization and smart demand participation," in *Innovative Smart Grid Technologies (ISGT), 2012 IEEE PES*, 2012, pp. 1-5.
- [115] L. Shang, D. Sun, and J. Hu, "Sliding-mode-based direct power control of grid-connected voltage-sourced inverters under unbalanced network conditions," *Power Electronics, IET*, vol. 4, pp. 570-579, 2011.
- [116] H. Jiabing and H. Bin, "Direct active and reactive power regulation of grid connected voltage source converters using sliding mode control approach," in *Industrial Electronics (ISIE), 2010 IEEE International Symposium on*, 2010, pp. 3877-3882.
- [117] T. Hornik and Q. C. Zhong, "Hinf; repetitive current controller for grid-connected inverters," in *Industrial Electronics, 2009. IECON '09. 35th Annual Conference of IEEE*, 2009, pp. 554-559.

- [118] T. Hornik and Z. Qing-Chang, "Hinf current control strategy for the neutral point of a three-phase inverter," in *Decision and Control and European Control Conference (CDC-ECC), 2011 50th IEEE Conference on*, 2011, pp. 2994-2999.
- [119] T. Hornik and Z. Qing-Chang, "A Current-Control Strategy for Voltage-Source Inverters in Microgrids Based on H inf and Repetitive Control," *Power Electronics, IEEE Transactions on*, vol. 26, pp. 943-952, 2011.
- [120] T. Hornik and Z. Qing-Chang, "Voltage control of grid-connected inverters based on Hinf and repetitive control," in *Intelligent Control and Automation (WCICA), 2010 8th World Congress on*, 2010, pp. 270-275.
- [121] T. Hornik and Z. Qing-Chang, "Hinf repetitive current-voltage control of inverters in microgrids," in *IECON 2010 - 36th Annual Conference on IEEE Industrial Electronics Society*, 2010, pp. 3000-3005.
- [122] Z. Qing-Chang and T. Hornik, "Cascaded Current - Voltage Control to Improve the Power Quality for a Grid-Connected Inverter With a Local Load," *Industrial Electronics, IEEE Transactions on*, vol. 60, pp. 1344-1355, 2013.
- [123] S. Hara, Y. Yamamoto, T. Omata, and M. Nakano, "Repetitive control system: a new type servo system for periodic exogenous signals," *Automatic Control, IEEE Transactions on*, vol. 33, pp. 659-668, 1988.
- [124] M. A. Abusara, M. Jamil, and S. M. Sharkh, "Repetitive current control of an interleaved grid-connected inverter," in *Power Electronics for Distributed Generation Systems (PEDG), 2012 3rd IEEE International Symposium on*, 2012, pp. 558-563.
- [125] L. Tao, H. Xiang, Y. Xu, Z. Ming, H. Qingyun, and H. Lang, "A novel repetitive control scheme for three-phase grid-connected inverter with LCL filter," in *Power Electronics and Motion Control Conference (IPEMC), 2012 7th International*, 2012, pp. 335-339.
- [126] M. A. Abusara and S. M. Sharkh, "Design of a robust digital current controller for a grid connected interleaved inverter," in *Industrial Electronics (ISIE), 2010 IEEE International Symposium on*, 2010, pp. 2903-2908.
- [127] D. Chen, J. Zhang, and Z. Qian, "Research on fast transient and  $6n \pm 1$  harmonics suppressing repetitive control scheme for three-phase grid-connected inverters," *Power Electronics, IET*, vol. 6, pp. 601-610, 2013.
- [128] A. Asbafkan, B. Mirzaeeian, M. Niroomand, and H. A. Zarchi, "Frequency adaptive repetitive control of grid connected inverter for wind turbine applications," in *Electrical Engineering (ICEE), 2013 21st Iranian Conference on*, 2013, pp. 1-6.
- [129] S. Jiang and F. Z. Peng, "Repetitive control of grid-connected inverter using a high resonance frequency LCL filter," in *Applied Power Electronics Conference and Exposition (APEC), 2013 Twenty-Eighth Annual IEEE*, 2013, pp. 2781-2787.
- [130] P. C. Loh, Y. Tang, F. Blaabjerg, and P. Wang, "Mixed-frame and stationary-frame repetitive control schemes for compensating typical load and grid harmonics," *Power Electronics, IET*, vol. 4, pp. 218-226, 2011.
- [131] G. Teng, G. Xiao, Z. Zhang, and Y. Lu, "A control method with grid disturbances suppression for a single-phase LCL-filter-based grid-connected inverter," in *Applied Power Electronics Conference and Exposition (APEC), 2012 Twenty-Seventh Annual IEEE*, 2012, pp. 1489-1493.
- [132] C. Dong, Z. Junming, and Q. Zhaoming, "An Improved Repetitive Control Scheme for Grid-Connected Inverter With Frequency-Adaptive Capability," *Industrial Electronics, IEEE Transactions on*, vol. 60, pp. 814-823, 2013.
- [133] Y. A. R. Mohamed and E. F. El-Saadany, "Adaptive Discrete-Time Grid-Voltage Sensorless Interfacing Scheme for Grid-Connected DG-Inverters Based on Neural-Network Identification and Deadbeat Current Regulation," *Power Electronics, IEEE Transactions on*, vol. 23, pp. 308-321, 2008.
- [134] Y. A. R. I. Mohamed and E. F. El-Saadany, "A Robust Natural-Frame-Based Interfacing Scheme for Grid-Connected Distributed Generation Inverters," *Energy Conversion, IEEE Transactions on*, vol. 26, pp. 728-736, 2011.
- [135] M. Chao and H. Dagui, "Comparative study of PI controller and fuzzy logic controller for three-phase grid-connected inverter," in *Mechatronics and Automation (ICMA), 2011 International Conference on*, 2011, pp. 2067-2071.
- [136] HOMER (The Hybrid Optimization Model for Electric Renewables). Available: [http://www.homerenergy.com/HOMER\\_pro.html](http://www.homerenergy.com/HOMER_pro.html)
- [137] V. K. Soni and R. Khare, "Optimal sizing of HRES for small sized institute using HOMER," in *Electrical Energy Systems (ICEES), 2014 IEEE 2nd International Conference on*, 2014, pp. 77-81.
- [138] N. A. b. A. Razak, M. M. bin Othman, and I. Musirin, "Optimal sizing and operational strategy of hybrid renewable energy system using homer," in *Power Engineering and Optimization Conference (PEOCO), 2010 4th International*, 2010, pp. 495-501.
- [139] J. L. Bernal-Agustín and R. Dufo-López, "Simulation and optimization of stand-alone hybrid renewable energy systems," *Renewable and Sustainable Energy Reviews*, vol. 13, pp. 2111-2118, 10// 2009.
- [140] The Hybrid Power System Simulation Model. Available: <http://www.ceere.org/rerl/projects/software/hybrid2/>
- [141] S. Phrakonkham, J.-Y. Le Chenadec, D. Diallo, G. Remy, and C. Marchand, "Reviews on Micro-Grid Configuration and Dedicated Hybrid System Optimization Software Tools: Application to Laos," *Engineering Journal*, vol. 14, pp. 15-34, 2010.
- [142] Hybrid-Renewable Optimization by Genetic Algorithms. Available: <http://hoga-renewable.es.tl/>



- [143] P. A. Stubberud and M. E. Jackson, "A Hybrid Orthogonal Genetic Algorithm for Global Numerical Optimization," in *Systems Engineering, 2008. ICSENG '08. 19th International Conference on*, 2008, pp. 282-287.
- [144] M. Castaneda, L. M. Fernandez, H. Sanchez, A. Cano, and F. Jurado, "Sizing methods for stand-alone hybrid systems based on renewable energies and hydrogen," in *Electrotechnical Conference (MELECON), 2012 16th IEEE Mediterranean*, 2012, pp. 832-835.
- [145] Ø. Ulleberg and R. Glöckner, "HYDROGEMS-Hydrogen energy models," in *Proceedings of WHEC*, 2002.
- [146] "HYDROGEMS."
- [147] H. H. I. Agreement, "Hydrogen Demonstration Project Evaluations," 2007.
- [148] *Renewable Alternativ Powersystems Simulation*. Available: <http://sourceforge.net/projects/rapsim/>
- [149] *Simulation and Optimization Model for renewable Energy Systems*. Available: [http://www.web.co.bw/sib/somes\\_3\\_2\\_description.pdf](http://www.web.co.bw/sib/somes_3_2_description.pdf)
- [150] *Transient Energy System Simulation Program*. Available: <http://sel.me.wisc.edu/trnsys/features/features.html>
- [151] J. Bélanger, L. A. Snider, J.-N. Paquin, C. Pirolli, and W. Li, "A modern and open real-time digital simulator of contemporary power systems," in *Proceedings of the International Conference on Power Systems Transients (IPST 2009), Kyoto, Japan, 2009*, pp. 2-6.
- [152] L.-A. Dessaint, K. Al-Haddad, H. Le-Huy, G. Sybille, and P. Brunelle, "A power system simulation tool based on Simulink," *Industrial Electronics, IEEE Transactions on*, vol. 46, pp. 1252-1254, 1999.
- [153] *RTDS Technologies: Real Time Power System Simulation*. Available: [www.rtds.com](http://www.rtds.com)
- [154] *PSCAD Home*. Available: <https://hvdc.ca/pscad>
- [155] *OPAL-RT*. Available: [www.opal-rt.com](http://www.opal-rt.com)
- [156] F. Ibarra Hernandez, C. A. Canesin, R. Zamora, F. Martina, and A. K. Srivastava, "Energy management and control for islanded microgrid using multi-agents," in *North American Power Symposium (NAPS), 2013*, 2013, pp. 1-6.
- [157] L. Yangkai, S. Xinchun, F. Chao, and M. Jianhui, "Hardware in-the-loop simulation system based on NI-PXI for operation and control of microgrid," in *Industrial Electronics and Applications (ICIEA), 2014 IEEE 9th Conference on*, 2014, pp. 1366-1370.
- [158] A. H. Etemadi, E. J. Davison, and R. Iravani, "A Generalized Decentralized Robust Control of Islanded Microgrids," *Power Systems, IEEE Transactions on*, vol. 29, pp. 3102-3113, 2014.
- [159] M. Farzinfar, M. Jazaeri, N.-K. C. Nair, and F. Razavi, "Stability evaluation of MicroGrid using real-time simulation," in *Power Engineering Conference (AUPEC), 2014 Australasian Universities*, 2014, pp. 1-6.
- [160] L. Lin-Yu and C. Chia-Chi, "Autonomous power management and load sharing in isolated micro-grids by consensus-based droop control of power converters," in *Future Energy Electronics Conference (IFEEC), 2013 1st International*, 2013, pp. 365-370.
- [161] L. Meng, J. C. Vasquez, J. M. Guerrero, and T. Dragicevic, "Agent-based distributed hierarchical control of dc microgrid systems."
- [162] M. Lexuan, T. Dragicevic, J. Guerrero, J. Vasquez, M. Savaghebi, and T. Fen, "Agent-based distributed unbalance compensation for optimal power quality in islanded microgrids," in *Industrial Electronics (ISIE), 2014 IEEE 23rd International Symposium on*, 2014, pp. 2535-2540.
- [163] L. Meng, T. Dragicevic, J. M. Guerrero, and J. C. Vasquez, "Dynamic Consensus Algorithm Based Distributed Global Efficiency Optimization of a Droop Controlled DC Microgrid," in *IEEE International Energy Conference*.
- [164] K. H. Ahmed, A. M. Massoud, S. J. Finney, and B. W. Williams, "A Survey of Control Techniques for Three -Phase Inverter-Based Distributed Generation," in *2nd International Conference on Microgrid*, 2011.
- [165] M. A. Sofla, L. Wang, and R. King, *Modeling and Control of Sustainable Power Systems*. Berlin Heidelberg: Springer Berlin Heidelberg, 2012.
- [166] J. Rodriguez, J. Pontt, C. A. Silva, P. Correa, P. Lezana, P. Cortes, *et al.*, "Predictive Current Control of a Voltage Source Inverter," *Industrial Electronics, IEEE Transactions on*, vol. 54, pp. 495-503, 2007.
- [167] D. G. W. Rahul Ganpat Mapari, "A Simple Predictive Pwm Voltage Controlled Technique for Implementation of Single Phase Inverter with Precesion Rectifier," *Journal of Engineering Research and Applications*, vol. 3, pp. 1772-1775, 2013.
- [168] X. C. M. Cubillos and L. C. G. d. Souza, "Using of H-Infinity Control Method in Attitude Control System of Rigid-Flexible Satellite," *Hindawi Publishing Corporation*, vol. 2009, pp. 1-9, 2009.
- [169] G. W. McLeary, *H-infinity Control Design Approach for Near-zero Speed Submarine Depth Control*: George Mason University, 2005.
- [170] T. Hornik and Z. Qing-Chang, "Voltage Control of Grid-Connected Inverters Based on  $H_\infty$  and Repetitive Control," in *IECON 2010 - 36th Annual Conference on IEEE Industrial Electronics Society*, 2010, pp. 3000-3005.