



Aalborg Universitet

AALBORG UNIVERSITY
DENMARK

LTE HetNet Mobility Performance Through Emulation with Commercial Smartphones

Jensen, Anders Riis; Pedersen, Klaus I.; Lauridsen, Mads; Mogensen, Preben; Faaborg, Janus

Published in:
Vehicular Technology Conference (VTC Spring), 2014 IEEE 79th

DOI (link to publication from Publisher):
[10.1109/VTCSpring.2014.7022979](https://doi.org/10.1109/VTCSpring.2014.7022979)

Publication date:
2014

Document Version
Accepted author manuscript, peer reviewed version

[Link to publication from Aalborg University](#)

Citation for published version (APA):
Jensen, A. R., Pedersen, K. I., Lauridsen, M., Mogensen, P., & Faaborg, J. (2014). LTE HetNet Mobility Performance Through Emulation with Commercial Smartphones. In Vehicular Technology Conference (VTC Spring), 2014 IEEE 79th (pp. 1-5). IEEE. I E E V T S Vehicular Technology Conference. Proceedings <https://doi.org/10.1109/VTCSpring.2014.7022979>

General rights

Copyright and moral rights for the publications made accessible in the public portal are retained by the authors and/or other copyright owners and it is a condition of accessing publications that users recognise and abide by the legal requirements associated with these rights.

- ? Users may download and print one copy of any publication from the public portal for the purpose of private study or research.
- ? You may not further distribute the material or use it for any profit-making activity or commercial gain
- ? You may freely distribute the URL identifying the publication in the public portal ?

Take down policy

If you believe that this document breaches copyright please contact us at vbn@aub.aau.dk providing details, and we will remove access to the work immediately and investigate your claim.

LTE HetNet Mobility Performance Through Emulation with Commercial Smartphones

Anders R. Jensen, Klaus I. Pedersen, Mads Lauridsen, Preben E. Mogensen
Aalborg University - Department of Electronic Systems, Aalborg, Denmark
Email: {arj, kip, ml, pm}@es.aau.dk

Janus Faaborg
Agilent Technologies, Aalborg, Denmark
Email: janus_faaborg@agilent.com

Abstract—In this paper we introduce a laboratory emulation setup for evaluation of Long Term Evolution (LTE) mobility performance in a co-channel heterogeneous network (HetNet). The setup consists of two eNodeB emulators, signal faders and release 9 LTE User Equipment (UE). It is shown how the LTE HetNet mobility performance varies depending on load conditions and the configuration of UE reporting events. Pico cell outbound handover to the macro cell are found to be particular challenging, especially for higher UE speeds. Finally, we discuss the prospects of the emulation setup and how it can be exploited to conduct further experiments towards gaining additional understanding of HetNet mobility performance for LTE UEs.

I. INTRODUCTION

Long term evolution (LTE) deployments with high power macro cells and low power pico cells have recently attracted a lot of attention in both industry and academia research. Deployment of low power pico cells is considered as one of the viable solutions to increase the capacity of cellular systems for hotspot areas with high traffic density. However, building heterogeneous networks (HetNet) with a mixture of different cell types also comes with a number of challenges. Mobility robustness and interference management challenges are identified for co-channel deployments where macro and pico cells are using the same carrier frequency. As an example, HetNet interference management challenges have been studied in [1]–[4], while mobility robustness challenges have been addressed in [5]–[8].

Published studies on LTE co-channel HetNet cases are mostly based on either theoretical analysis or extensive Monte-Carlo simulations, while only few observations from field trials have been published; see e.g. [9], [10]. Compared to simulation, the emulation method uses LTE compliant equipment and does not rely on modeling of either user equipment (UE) or eNodeB behavior. This allows for true mobility performance assessment given the imposed channel conditions. In this study, we therefore focus on presenting a emulation setup with two base station emulators that allows assessment of mobility performance of commercially available LTE UEs for co-channel HetNet cases when moving between a macro and pico cell. Our objective is to first outline the developed measurement setup, and secondly to present performance results from such experiments. The experimental findings are compared against observations from a recent simulation-based HetNet mobility study in 3GPP as reported in [8], and differences/similarities are high-lighted. In particular, our focus is on quantifying how co-channel HetNet mobility performance depends on load

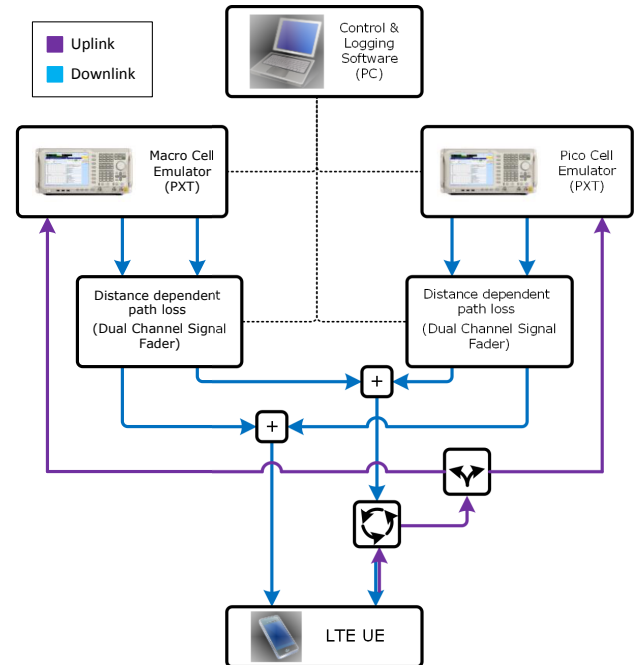

Fig. 1: HetNet emulation setup.

conditions, whether pico cell inbound or outbound handovers are more challenging, mobility performance depending on the configuration of UE reporting events, whether there are noticeable differences in HetNet mobility performance when using different LTE UEs, etc. Finally, the experimental findings from this paper can serve as input to future simulation-based studies to further refine the underlying modeling assumptions.

The rest of the paper is organized as follows: Section II introduces the test setup and section III describes the emulation scenario including the parameters used. Section IV includes illustrations and discussions based on the emulation results. Finally the conclusions are summarized in Section V and Section VI present future work topics.

II. HETNET EMULATION SETUP

To emulate a LTE HetNet a state-of-the-art test setup illustrated in Fig. 1 have been developed. The setup is centered around two Agilent Technologies E6621A (PXT) [11] instruments used for emulation of the macro and pico eNodeBs. Single tap channel faders together with combiners, circulators, and splitters are used to interconnect eNodeBs and UE with fading of the downlink signals. Uplink signals are

unfaded which enables reliable uplink message logging from the eNodeBs.

Configuration of the eNodeB emulators, programming of signal faders, and information logging are handled by a PC running custom software. The setup is 3GPP release 9 compliant and the emulations have been carried out using two category 3 release 9 UEs. The UEs are from different vendors, run different operating systems, and are equipped with LTE chipsets from same vendor. To emulate data traffic load from other users the PXT allows unused physical downlink shared channel (PDSCH) resources to be filled with random data. The signal faders are custom built hardware with support of high speed (1 ms update rate) continuous fading with a dynamic range of 80 dB. The speed and dynamic range make the signal faders suitable for emulating both distance dependent fading and shadow fading. The faders are controlled via LAN and features the IEEE1588 precision time protocol [12] which allows for full time synchronization between faders and data logged from the eNodeBs. The synchronization ensures that every network event logged from the eNodeBs can be associated with a given RF signal level set by the faders.

Emulation results are obtained by logging and analyzing all LTE protocol messages exchanged between the UE and the eNodeBs. There is no requirement for any specific UE logging interface as data is solely retrieved from the eNodeBs. This makes the setup UE vendor independent which is highly desirable in emulation campaigns including UEs from various vendors. From the protocol messages, mobility key performance indicators (KPIs) like cell ping-pong (described in [8]), radio link failures (RLFs), and handover failures can be extracted. In this study, information from radio resource control (RRC) messages [13] are used to identify events like inbound (macro to pico) and outbound (pico to macro) handovers. To obtain UE measured reference signal received power (RSRP) and reference signal received quality (RSRQ) values for serving and neighbor cells the UE was configured to send periodical measurement reports.

III. EMULATION SCENARIO

In LTE handovers are network controlled and UE assisted. UEs are configured with reporting event A3 [13], which is triggered if the target cell RSRP is *offset* decibels larger than the serving cell for a time period of *time-to-trigger* (TTT). When the source cell receives the A3 event from the UE, a handover to the target cell is initiated. The considered A3 parameter settings are summarized in Table I. The settings originate from a previous 3GPP HetNet mobility study [8], where parameter set 3 was observed to be the most attractive configuration for a co-channel HetNet scenario with macro and pico cells. Parameter sets 1 and 2 are conservative settings, since longer TTT and additional Layer-3 filtering of RSRP measurements are used for triggering A3. Parameter sets 4 and 5 are considered more aggressive as both short TTT, marginal Layer-3 filtering, and low values of A3 offset are used. Thus, the considered A3 parameter sets represent cases where handover from source to target cell is ranging from very early (aggressive setting) to very late (conservative setting).

The signal faders connecting the PXTs to the UE are configured to emulate the scenario pictured in Fig. 2 with one

TABLE I: Configuration parameter sets (Table 5.3.2.1, [8]).

Profile set nr.	1	2	3	4	5
Time-To-Trigger (TTT) [ms]	480	160	160	80	40
A3 offset [dB]	3	3	2	1	-1
RSRP L3 filter K	4	4	1	1	0

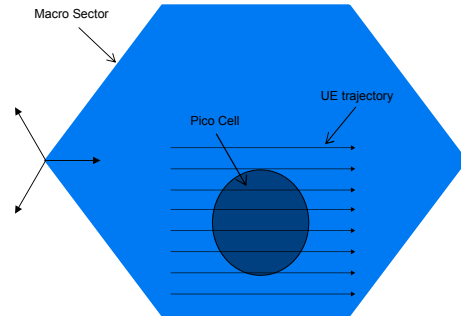

Fig. 2: Sketch of emulation grid.

macro and one pico cell. In the emulations the UE moves along the horizontal trajectories with constant speed with each trace covering a distance of 200 meters. An emulation run consists of 66 signal traces with a vertical distance of 2 meters between two adjacent traces. The main assumptions for the considered emulation setup are summarized in Table II. Notice that the assumed path loss model and antenna gains for macro and pico cell are in coherence with the HetNet simulation assumptions in [14]. Shadow fading is omitted from the emulation to ease interpretation of the results. Fig. 3 illustrate the received UE power at different locations in the emulation grid, Fig. 2, for the macro and pico cells.

TABLE II: Cell power, fading, and signal settings.

Parameter	Macro	Pico
Grid location (x,y) [m]	(0,0)	(300,-200)
Min. coupling loss [dB]	73	73
DL Tx Power [dBm]	46	30
Path-Loss [dB], where R is distance [km]	$128.1 + 37.6 \log_{10}(R)$	$140.7 + 36.7 \log_{10}(R)$
Antenna pattern	Tabel A.2.1.1-2 in [14]	Omni-directional
Antenna gain [dBi]	14	5
Downlink carrier freq.	2655 MHz	
Uplink carrier freq.	2535 MHz	
Bandwidth	10 MHz	
Transmission mode	3	
Physical Cell ID	0	2
HARQ retransmissions	4	
PDSCH MCS Index	1 (QPSK modulation and code rate 1/5)	
PDSCH codewords	1	
PDCCH aggregation	Level 8	

Moreover, the two PXTs are configured with different physical cell IDs such that transmission of common reference signals (CRS) from the macro and pico cells are non-colliding. The two cells are not time-synchronized. For the sake of simplicity, conservative link adaptation for the PDSCH and physical downlink control channel (PDCCH) are applied, such that the PDSCH and PDCCH always is encoded with QPSK 1/5 and aggregation level 8, respectively. These link adaptation settings are chosen to have highly reliable downlink RRC signaling to the UE as this is important for the mobility performance. Experiments are conducted where the PDSCH is solely used for RRC signaling to the UE (i.e. corresponding to unloaded), and cases where both cells transmit PDSCH data

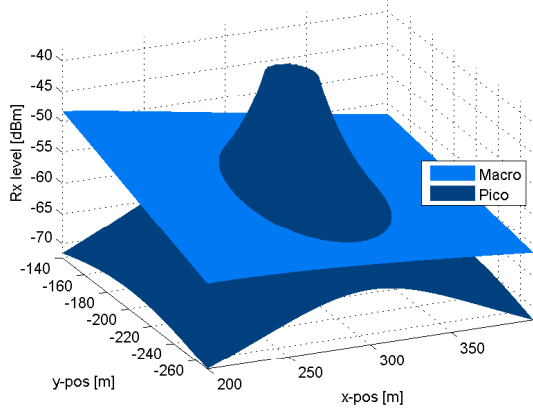

Fig. 3: Grid power of macro and pico cells.

TABLE III: RRC timer and counter settings.

t304	t310	t311	n310	n311
100 ms	1000 ms	1000 ms	1	1

on all physical resource blocks (PRBs) to emulate a full loaded scenario. Finally, the essential UE RRC parameter settings influencing on triggering of RLF and re-establishment events are summarized in Table III [13]. The RRC parameter settings are in line with the assumptions in [8].

IV. EMULATION RESULTS

This section presents the outcome from an emulation campaign covering the five profile sets in table I at different UE speeds. For the specified profile sets it is chosen to include emulations with both loaded and unloaded cells and to use two different UEs. Results are analyzed and evaluated with respect to location of the inbound and outbound handovers, RLF, and the UE reported RSRP values.

A. Loaded Versus Unloaded Cells

Figures 4 and 5 illustrate the emulation results at 30 km/h for profile set 3 with and without cell load, respectively. The figures visualize the emulation results from the 66 individual traces. The color of the stacked traces indicate the current state of the UE connection. The pico cell is marked in the center of the plots and the macro-pico cell power threshold is indicated with a dotted line. All traces are executed with the UE moving from left to right. For traces passing through the pico coverage area the UE should ideally carry out an inbound macro to pico handover followed by an outbound pico to macro handover.

Fig. 4 shows general good and consistent performance with all handovers successfully completed. In the top of the pico cell coverage area, the positions of a few inbound handovers are deviating slightly from the general picture. The case with loaded cells, Fig. 5, reveals some unexpected effects. All inbound handovers are completed successfully although these are executed earlier relative to the case with unloaded cells. For outbound handovers two different behaviors are observed. For traces passing close to the pico cell center the handovers behave similar to the inbound handovers with early execution

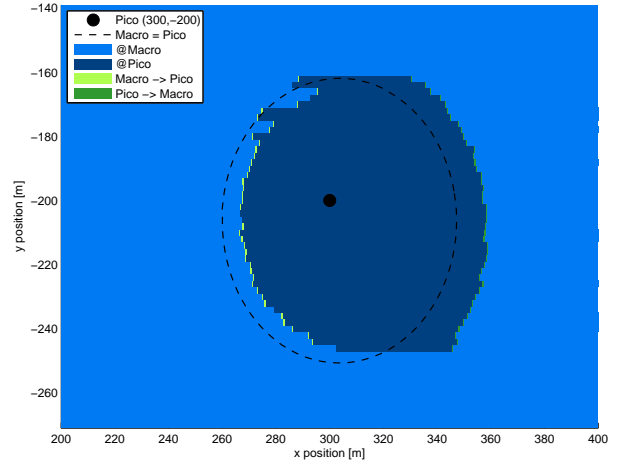

Fig. 4: Profile Set 3, UE speed 30 km/h, cells unloaded.

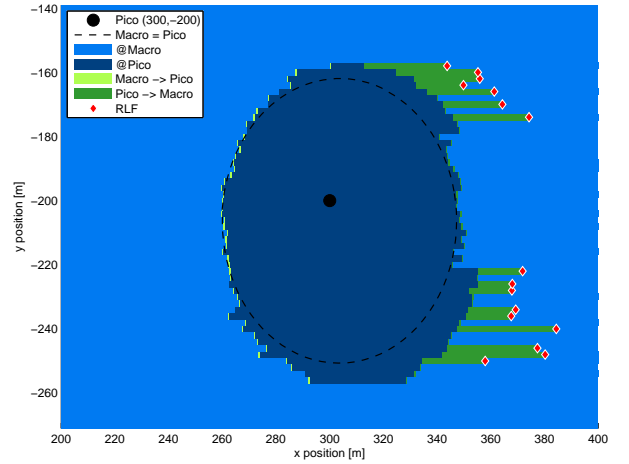

Fig. 5: Profile Set 3, UE speed 30 km/h, cells fully loaded.

and good performance. For traces not passing close to the pico cell center outbound handovers are initiated similar to the emulation with unloaded cells resulting in a large amount of failed handovers. This behavior is further studied in the next section.

B. Reported RSRP Values

As observed in Fig. 4 and 5 the handover procedure is initiated at different positions depending on whether the cells are loaded or unloaded. Handovers are triggered based on UE measured RSRP values which are independent of cell loading. In Fig. 6 the RSRP values are plotted for the single trace located at $y = -222\text{m}$ in both loaded and unloaded conditions. The shift in inbound handover is confirmed by the reported RSRP values. These indicate a pico (target cell) RSRP difference of 2-3 dB going from an unloaded to loaded network. With respect to the outbound RSRP values no difference is observed. When analyzing traces passing closer to the pico cell center a different outbound behavior is observed. Fig. 5 shows an abrupt change between two adjacent traces, e.g. $y = -220\text{m}$ and $y = -222\text{m}$, under loaded conditions. The corresponding RSRP values are plotted in Fig. 7. Moving only 2 meters closer to the pico cell reveal a outbound RSRP value change of 3 dB. The jump in the reported RSRP levels can

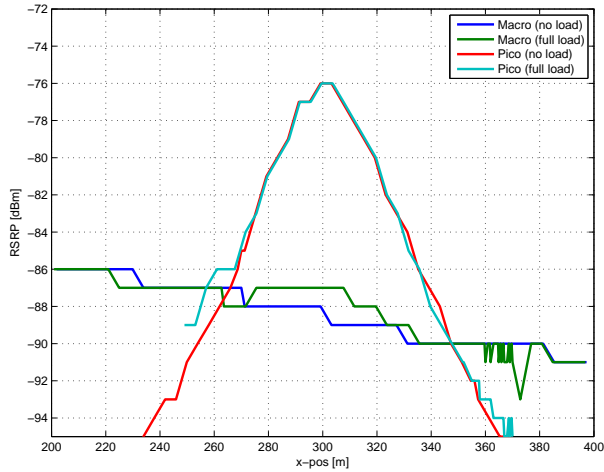

Fig. 6: UE reported RSRP values in unloaded and loaded cell conditions for $y = -222\text{m}$.

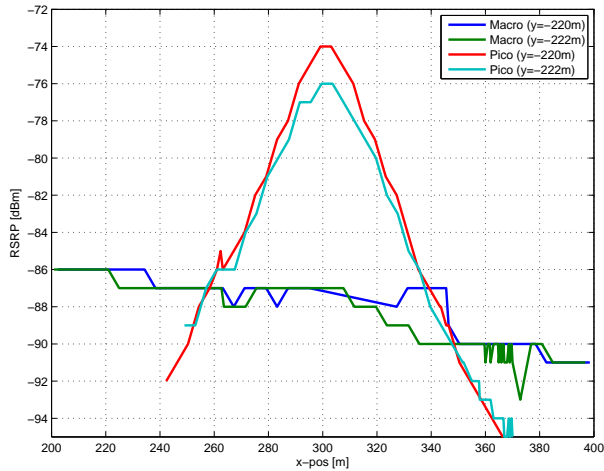

Fig. 7: UE reported RSRP values in loaded cell conditions for $y = -220\text{m}$ and $y = -222\text{m}$.

not be explained by the cell power levels in the outbound handover region as the two adjacent traces deviate with less than 0.3 dB and 0.1 dB for the macro and pico respectively. However, the maximum received power from the pico cell is increased by approximately 1.5 dB for the trace closest to the center ($y = -220\text{m}$), resulting in a steeper negative slope in the outbound area.

From a system perspective accurate RSRP measurements are essential and the observed behavior, due to change in cell load, is difficult to explain as:

- Equal cell power in handover region should lead to good measurements of both source and target cell
- The common reference signals from both cells are non-colliding
- Better measurements is expected at lower emulation speeds but the inaccuracy of cell RSRP is observed for all speeds emulated

However, all significant RSRP estimation errors are observed only for the target cell and never the source cell. The sudden shift of outbound handover time/position, when

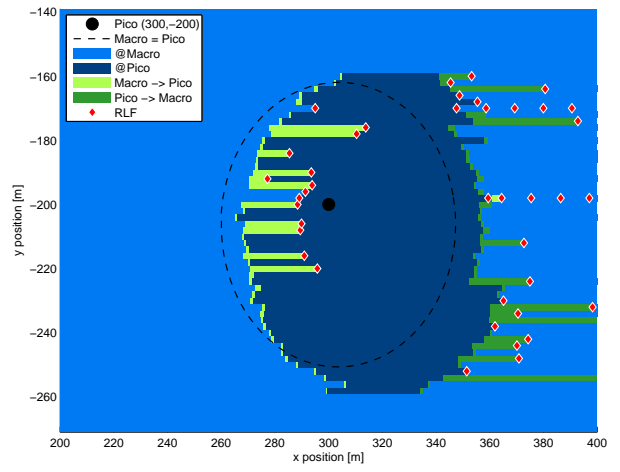

Fig. 8: Profile Set 1, UE speed 60 km/h, cells fully loaded.

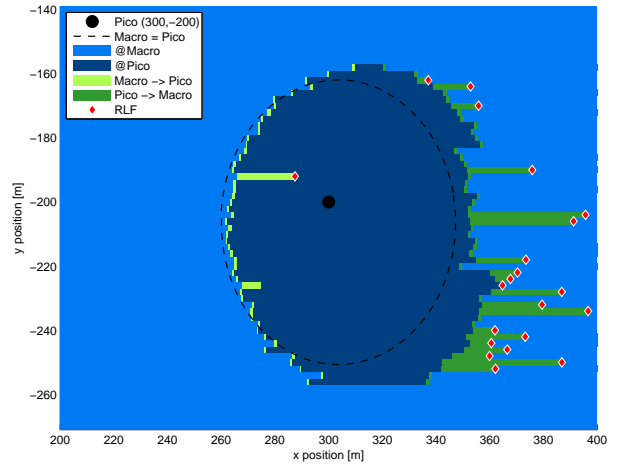

Fig. 9: Profile Set 2, UE speed 60 km/h, cells fully loaded.

changing from $y = -220\text{m}$ to $y = -222\text{m}$, is remarkable. The marginal differences in cell signal levels and gradients can not explain this. The same behavior is observed on UEs from two different manufactures both utilizing LTE chipsets from the same vendor.

C. The Effects of UE Speed and Handover Parameters

The different sets of A3 event parameters given in Table I have a significant impact on mobility performance. As an example profile set 1 and 2 has a TTT of 480 ms and 160 ms respectively. With a UE moving at 60 km/h this results in a handover position difference of 5.3 m. Comparing Fig. 8 and 9 confirms a relative distance shift of about 5 meters. For 30 km/h and faster UE speeds, it is observed that profile set 1 results in an increased amount of inbound RLFs. The fast changes of the cell signal level combined with large TTT values result in a poor radio link from the source cell to the UE and due to this, the UE often fails to successfully decode the handover message and the handover is never executed.

Fig. 10 illustrates 120 km/h emulation with profile set 5 and it does include a significant amount of cell ping-pong when the UE is located in the handover region due to the negative A3 offset.

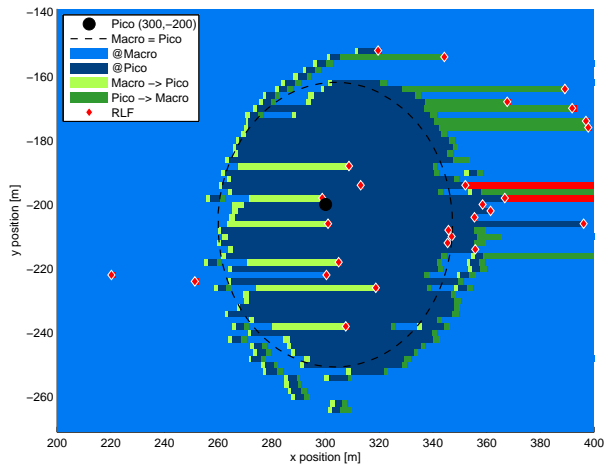

Fig. 10: Profile Set 5, UE speed 120 km/h, cells fully loaded.

D. Different UE's

As previously mentioned the developed emulation setup allows comparison of mobility performance for different commercial LTE UEs. This is valuable to benchmark if there is consistent A3 reporting for different UEs, leading to the same mobility performance, or whether there are noticeable differences in the performance. The experiments conducted in this study with two different LTE UEs (same LTE chipset vendor) showed nearly identical mobility performance. Additional experiments with a larger variety of UEs are therefore needed before drawing final conclusions on whether the mobility performance differs depending on the UE.

V. CONCLUSION

A state-of-the-art emulation setup that enables studies of LTE mobility performance with commercially available LTE UEs have been developed and presented in this study. We used the setup to study co-channel HetNet mobility performance between macro and pico cells. Our studies reveal several interesting findings. First, we observe that handovers are executed earlier in the presence of cell load interference. This is caused by the UE systematically overestimating the target cell RSRP when there is interference, although the RSRP in principle should be independent of the inter-cell interference level. The type of handovers that are most challenging is found to be outbound handovers from the pico and back to the macro. The latter is in line with observations from simulation studies reported in [5]–[8]. Among the considered parameter sets for the A3 event, set 3 in Table I seems to offer a reasonable tradeoff to achieve good overall mobility performance. Experiments with two different LTE UEs show nearly identical mobility performance. However, it should be stressed that the two used LTE UEs are equipped with a modem from the same chipset vendor, so additional experiments with a larger variety of UEs are needed before drawing final conclusions on to what extent the mobility performance is depending on the used UE.

VI. FUTURE WORK

This paper introduces a test setup which enables a range of interesting possibilities for future studies of mobility performance in heterogeneous networks. Our next step is to conduct

extended emulations which include shadow fading and low speed scenarios for pedestrian use cases. This will enable collection of KPI statistics and comparison with previous HetNet studies like [6]. Additionally we want to study macro offloading using pico cells with range extension, using a broader selection of commercially available UEs.

ACKNOWLEDGMENT

We would like to thank Agilent Technologies for supplying equipment for the HetNet emulation setup and general support. The work is partly funded by the Danish National Advanced Technology Foundation and the 4th Generation Mobile Communication and Test Platform.

REFERENCES

- [1] A. Damnjanovic, et.al., "A Survey on 3GPP Heterogeneous Networks", in IEEE Wireless Communications, Pages 10-21, Vol. 18, Issue 3, June 2011.
- [2] A. Damnjanovic, et.al., "UEs role in LTE Advanced Heterogeneous Networks", in IEEE Wireless Communications, Pages 164-176, Vol. 50, Issue 2, February 2012.
- [3] D. Lopez-Perez, et.al., "Enhanced Intercell Interference Coordination Challenges in Heterogeneous Networks", in IEEE Wireless Communications, Pages 22-30, Vol. 18, Issue 3, June 2011.
- [4] K.I. Pedersen, et.al., "Enhanced Inter-Cell Interference Coordination in Co-Channel Multi-Layer LTE-Advanced Networks", in IEEE Wireless Communications Magazine, pp. 120-127, June 2013.
- [5] S. Barbera, P. Michaelsen, M. Saily, K.I. Pedersen, "Improved Mobility Performance in LTE Co-Channel HetNets Through Speed Differentiated Enhancements", in IEEE Proc. Globecom, December 2012.
- [6] S. Barbera, P.H. Michaelsen, M. Saily, K.I. Pedersen, "Mobility Performance of LTE Co-Channel Deployment of Macro and Pico Cells", in IEEE Proc. WCNC, April 2012.
- [7] K.I. Pedersen, S. Barbera, P-H. Michaelsen, C. Rosa, "Mobility Enhancements for LTE-Advanced Multilayer Networks with Inter-Site Carrier Aggregation", IEEE Communications Magazine, May 2013.
- [8] 3GPP TR 36.839, "Evolved Universal Terrestrial Radio Access (E-UTRA); Mobility enhancements in heterogeneous networks", V11.1.0 (2012-12).
- [9] P. Okvist, A. Simonsson, "LTE HetNet Trial - Range Expansion including Micro/Pico Indoor Coverage Survey", in IEEE Proc. VTC, (2012-9).
- [10] A. Ghosh, et.al., "Heterogenous cellular networks: From theory to practice", in IEEE Communications Magazine, June 2012.
- [11] Agilent Technologies E6621A PXT Wireless Communications Test Set, Additional information available at www.agilent.com.
- [12] 1588-2008 - IEEE Standard for a Precision Clock Synchronization Protocol for Networked Measurement and Control Systems.
- [13] 3GPP TS 36.331, "Evolved Universal Terrestrial Radio Access (E-UTRA); radio resource control (RRC); protocol specification", Version 9.14.1 (2013-4).
- [14] 3GPP TR 36.814 "Evolved Universal Terrestrial Radio Access (E-UTRA); Further advancements for E-UTRA physical layer aspects" Version 9.0.0 (2010-3).