



Aalborg Universitet

AALBORG UNIVERSITY
DENMARK

Non-Destructive Investigation on Short Circuit Capability of Wind-Turbine-Scale IGBT Power Modules

Wu, Rui; Iannuzzo, Francesco; Wang, Huai; Blaabjerg, Frede

Published in:

Proceedings of the International Conference on Wind energy Grid-Adaptive Technologies, WEGAT 2014

Publication date:

2014

Document Version

Early version, also known as pre-print

[Link to publication from Aalborg University](#)

Citation for published version (APA):

Wu, R., Iannuzzo, F., Wang, H., & Blaabjerg, F. (2014). Non-Destructive Investigation on Short Circuit Capability of Wind-Turbine-Scale IGBT Power Modules. In Proceedings of the International Conference on Wind energy Grid-Adaptive Technologies, WEGAT 2014 Chungbuk University, Korea.

General rights

Copyright and moral rights for the publications made accessible in the public portal are retained by the authors and/or other copyright owners and it is a condition of accessing publications that users recognise and abide by the legal requirements associated with these rights.

- ? Users may download and print one copy of any publication from the public portal for the purpose of private study or research.
- ? You may not further distribute the material or use it for any profit-making activity or commercial gain
- ? You may freely distribute the URL identifying the publication in the public portal ?

Take down policy

If you believe that this document breaches copyright please contact us at vbn@aub.aau.dk providing details, and we will remove access to the work immediately and investigate your claim.

Non-Destructive Investigation on Short Circuit Capability of Wind-Turbine-Scale IGBT Power Modules

Rui Wu *, Francesco Iannuzzo *, Huai Wang *, and Frede Blaabjerg *

Abstract – This paper presents a comprehensive investigation on the short circuit capability of wind-turbine-scale IGBT power modules by means of a 6 kA/1.1 kV non-destructive testing system. A Field Programmable Gate Array (FPGA) supervising unit is adopted to achieve an accurate time control for short circuit tests, which enables to define the driving signals with an accuracy of 10ns. Thanks to the capability and the effectiveness of the constructed setup, oscillations appearing during short circuits of the new-generation 1.7 kV/1 kA IGBT power modules have been evidenced and characterized under different collector voltage.

Keywords: Non-Destructive Testing, Short Circuit, Insulated Gate Bipolar Transistor (IGBT), Power Module

1. Introduction

In modern power electronics systems, there are increasing demands to improve whole system endurance and safety level while reducing manufacturing and maintenance costs [1]. There are a lot of research efforts devoted to increase power electronic systems reliability by introducing power devices fault-tolerant capability [2], [3], however, the number of extra components also increases substantially, which unavoidably leads to more manufacturing and maintenance costs. Recently, a physics-of-failure analysis is proposed to improve the reliability of critical components in power electronic systems. This approach is a methodology based on root-cause failure mechanism analysis and the impact of materials, defects, and stresses on power electronics reliability, which could be the future trend in the multidisciplinary research direction. Therefore, the root-cause failure mechanism analysis is becoming more important in recent reliability research [4].

According to a questionnaire for manufacturers, semiconductor devices are considered as the most critical and fragile component in industrial power electronic systems [5]. Based on another survey, semiconductor failure and soldering joint failure in power devices take up to 34 % of power electronic system failures [6]. Because Insulated Gate Bipolar Transistors (IGBTs) are one of the most critical components as well as the most widely used

power devices in industrial power electronic systems in the range above 1 kV and 1 kW [6], the reliability of IGBTs has drawn more and more attention. In particular, the ability of withstanding abnormal conditions (e.g. short circuits or overloads), is strictly required to achieve sufficient robustness in various critical applications, especially the ones where maintenance costs are very high, like MW-scale wind turbine systems [7], [8]. Because of the relatively low cost and feasibility of maintenance [9], [10], power modules are the most used packages in medium and high power applications, for instance, wind turbines systems [7]. The physics-of-failure analysis on IGBT power modules has been carried out in the recent research, where both the wear-out failure and catastrophic failure triggered by single event overstress have been studied to identify the failure mechanisms, whereas the short circuit failure mechanism is still a hot topic [11], [12].

Several research efforts have been devoted in the past to the study of the short circuit behavior of IGBT modules. In [13], the short circuit capability was studied by repetitive low energy level short circuit tests, and it revealed that the short circuit current reduces with testing time due to the Al metallization layer degradation and the on-state resistance increase. In [14], short circuit current differences among IGBT modules from a production lot were investigated. In [15], [16], an electro-thermal model based on a physical approach was also built up to simulate the current mismatch and thermal imbalance inside the IGBT chip during short circuits. However, in the prior-art studies, there is still a lack of method to experimentally observe the electrical behavior of IGBT power modules during short circuit, especially devoted to the occurrence of oscillations.

Recently, several non-destructive testing concepts have

* Department of Energy Technology, Aalborg University, Aalborg, Denmark. (rwu@et.aau.dk, fia@et.aau.dk, hwa@et.aau.dk, fbl@et.aau.dk)

been proposed to perform repetitive short circuit testing of IGBTs avoiding damages. The implementation of non-destructive testing systems for discrete IGBTs (up to 100 A) and for higher power IGBT modules (up to 2.4 kA) were discussed in [17] and [18], respectively, the main focus of which was to study the IGBTs short circuit behavior with temperature at various electrical conditions.

In this work, a state-of-the-art non-destructive tester (NDT) is used with a capability of 6 kA/1.1 kV which is appropriate for the assessment of wind-turbine-scale IGBT modules behavior under short circuit conditions. A Field Programmable Gate Array (FPGA) controller provides a precise short circuit time control of 10 ns and, consequently, accurate electrical measurements. By means of the NDT, a comprehensive investigation on the short circuit behavior of a commonly used high power IGBT module for wind power application has been carried out, especially focusing on the oscillations occurrence. The paper is organized as follows: Section II describes the principle and structure of the NDT, including some design details, and FPGA-based time settings. Section III presents the investigation on the short

circuit behavior of a 1.7 kV/1 kA IGBT module with an accurate time control by means of the NDT equipment, mainly focusing on the oscillations taking place during short circuit. Section IV concludes the paper with discussions

2. Description of Non-destructive Testing System

Short circuit tests are very stressing because both high voltage and high current are applied to IGBTs at the same time. Such a high density power shock can damage IGBTs within several μ s. For the above reason, a non-destructive testing equipment has been constructed whose peculiarity is to accurately define the testing times in order to finely control the short circuit duration. Moreover, a protection circuit avoids the destruction of the device under test (DUT), allowing the user to perform post-failure analyses. The picture and the main circuit of the discussed equipment are shown in Fig.1 and Fig. 2.

2.1 IGBT Short Circuit Definition

There are two different short-circuit types: Type 1 short circuit happens during the IGBT turn-on, while Type 2 short circuit happens when the IGBT is at on-state, as illustrated in Fig. 3. The NDT can provide both short circuit types by different configuration and control time schemes. In this study, investigations have been concentrated on Type 1 short circuit, whose control time schemes will be further illustrated in Section II, Part 3.

2.2 Structure and Parameters of Testing System

Fig. 1 shows a photograph of the laboratory setup, the dimension of which is around 1 m wide. The electrical schematic of the NDT is shown in Fig. 2, where two main

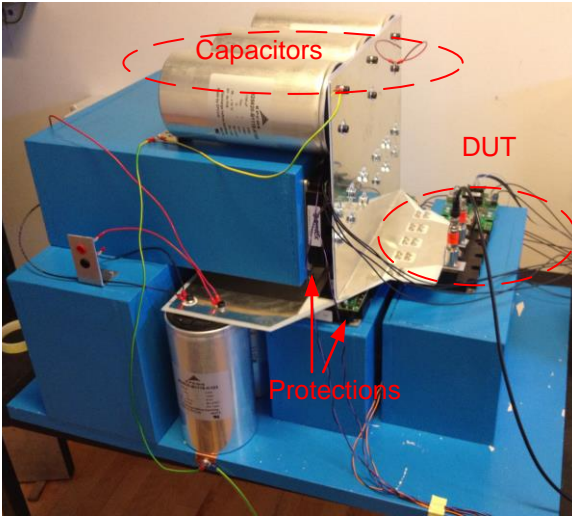

Fig. 1. Picture of the Non-destructive testing setup.

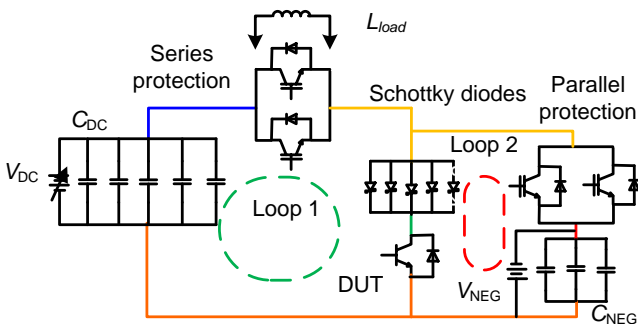

Fig. 2. The power circuit schematic of the non-destructive testing setup.

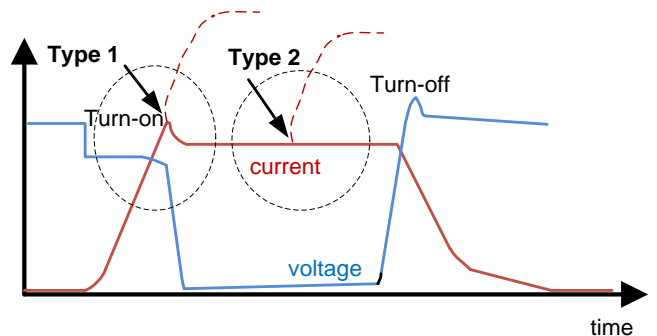

Fig. 3. Two types of short-circuits: Type 1 occurs during turn-on, Type 2 occurs during conduction state.

loops are evidenced, namely Loop 1 and Loop 2. As illustrated in Fig. 2, the NDT includes the following parts: Device under Test (DUT), a series protection, a parallel protection, a load inductance L_{load} , a DC link capacitance C_{DC} , and a high voltage power supply V_{DC} , some Schottky diodes, and a negative-voltage capacitance C_{NEG} with the corresponding negative voltage supply V_{NEG} .

The high-voltage power supply charges up a high-voltage capacitor bank C_{DC} , whose stored energy is used for the tests. The on-state series protection switch is turned off right after the test in order to save the DUT. A busbar has been designed with the aid of Computer-Aided-Design (CAD) to minimize the overall circuit inductance, including the intrinsic inductances of the series protection and the capacitors. The mutual coupling of the busbar components has also been taken into account. A 100 MHz FPGA provides the driving signals to the DUT and the protection switches through optical fibers; it provides the precise time control to the electrical measurement system as well. The remote control and data acquisition is achieved by a Personal Computer (PC) which supervises the operations by connecting an oscilloscope via an Ethernet link and the FPGA board through an RS-232 bus. Two commercial IGBT drivers drive the protection switches and the DUT respectively. In order to perform short circuits, the corresponding protection circuit on the DUT drivers has been deactivated. During tests, collector current, collector voltage and gate voltage waveforms are acquired.

The operating principle is as follows: as shown in Fig. 2, the power circuit is divided into two loops -Loop 1, including the series protection, and Loop 2, including the parallel protection; the DUT is located in the common branch. Table 1 gives the specifications of the major components of Fig. 2. The tester is operated in a standard single-shot way, so that the energy stored in the capacitors C_{DC} is used for the tests. C_{DC} and C_{NEG} are composed of five and three capacitors in parallel, respectively, in order to reduce the intrinsic stray inductances. The same principle has been adopted for the two switches of the series protection, the two switches of the parallel protection and the five Schottky diodes.

Loop 2 is designed to improve the performance of the NDT. In fact, the capability to zero the DUT current is strictly dependent on the series protection’s performance. However, the turn-off transition of the series protection is non-ideal because of the typical IGBT current tail, which would still flow through the DUT. To avoid this effect and divert the current tail, the parallel protection is fired up together with the series one. As demonstrated in [17], [19], a negative voltage biases a capacitor bank C_{NEG} in order to enhance the voltage fall promptness during IGBT turn-on.

Finally, to avoid a negative current flowing through the DUT, the Schottky diode bank is placed in series with DUT.

Table 1. Specifications and main components of power circuit in the non-destructive testing system.

Characteristic	Value
Maximum voltage	1.1 kV
Maximum current	6 kA
C_{DC} capacitors	5 x 1100 μ F
Main loop (Loop 1) stray inductance	37 nH
Devices in series protection	2 x Dynex DIM1500ESM33-TS000, 3 kA/ 3.3 kV
Devices in parallel protection	2 x Mitsubishi CM1200HC-66H, 2.4 kA/ 3.3 kV

2.3 Operating Principle and Time Settings

As mentioned before, Type 1 short circuit has been performed in this study, therefore the load inductance L_{load} has been removed. Referring to Fig. 2 and Fig. 4, the operating sequence is the following: before tests, the series protection is on and the parallel protection is off. Loop 1 only includes the stray inductance and the Schottky diodes behave almost ideally, so the DUT is connected directly to the C_{DC} capacitors. During the tests, the DUT turns on in short circuit conditions. After a precisely defined period, the series protection is switched off; meanwhile the parallel protection is turned on to avoid the undesirable tail current through the DUT.

The supervising unit is driven by a 100 MHz oscillator to achieve a time resolution of 10 ns for all control signals in Fig. 4. Each FPGA timer is 32 bits wide, so that a maximum time of more than 40 second can be achieved for each control signal.

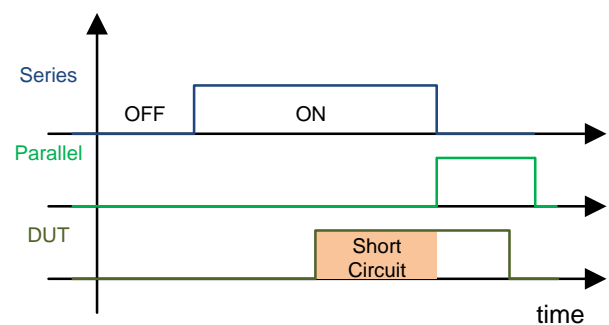

Fig. 4. Timing settings for Type 1 short circuits.

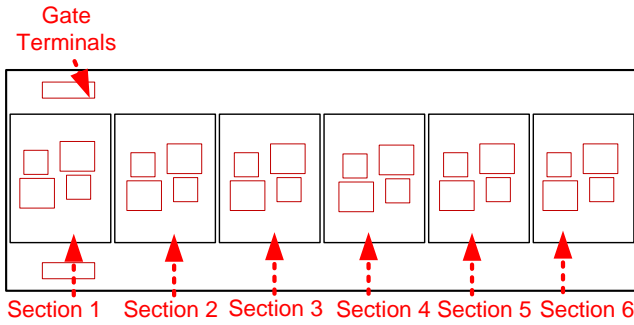

Fig. 5. Geometry of the studied 1.7 kV/1 kA IGBT power modules internal structure, section 1 is closer to the gate leads whereas section 6 is the farthest from the gate leads.

3. Experimental Investigation

3.1 IGBT Power Module Information

The developed NDT system has been utilized to study the short circuit behavior of a 1.7 kV/1 kA IGBT module, widely used in wind turbine systems. The DUT's main specifications are summarized in Table 2. It is noted that the rated short-circuit current is 4 kA and the peak gate voltage withstanding capability is +/- 20 V. As shown in Fig. 5, inside the module there are six identical sections connected in parallel to increase the power module's current capability. Each section includes two IGBT chips and two freewheeling diode chips, which are connected in half-bridge configuration.

Table 2. Main specifications of the IGBT module under test.

Characteristic	Value
Collector-emitter voltage V_{CES}	1.7 kV
Continuous DC collector current I_{Cnom}	1 kA
Rated short circuit current I_{SC}	4 kA
Gate-emitter peak voltage V_{GES}	+/- 20 V
Internal gate resistance	4 Ω
Number of parallel sections	6

3.2 Acquisitions of IGBT Oscillations during Short Circuits

By means of the described non-destructive tester, short circuit tests have been aimed to evidence the oscillations occurrence. Figure 6 reports a short circuit test where some dangerous oscillations happen. The applied short circuit test conditions were: collector voltage 900 V and gate pulse duration 2.3 μ s. Figure 6 (b) shows the detailed waveforms of the same short circuit test. The waveforms reported in the

figure were obtained by increasing step by step the gate pulse duration until oscillations appeared. As it is evident from Fig. 6, diverging oscillations can be found both on the gate voltage and on the collector voltage, taking place at about 1.7 μ s from the trigger instant; i.e. much earlier than the gate turn off edge. This observation suggests that such a phenomenon happens spontaneously, evidencing a possible instability mechanism. It is worth noting that longer gate pulses would have led to the gate breakdown, as the oscillation amplitude kept diverging up to the dangerous value of about 25 V - much higher than the gate voltage withstanding capability (refer to Fig. 6 and Table 2).

3.3 Dependence between Oscillation and Applied Collector Voltage

To further investigate the dependence of the above phenomenon on the applied conditions, several more experiments have been performed. Figure 7(a) shows the gate waveforms obtained at increasing voltages from 400 V to 900 V. It shows that the oscillations happen at different

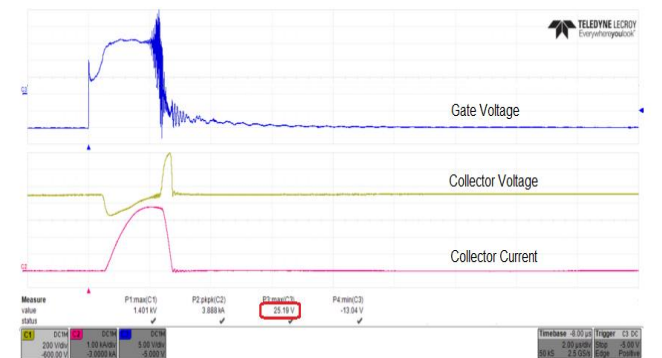

(a)

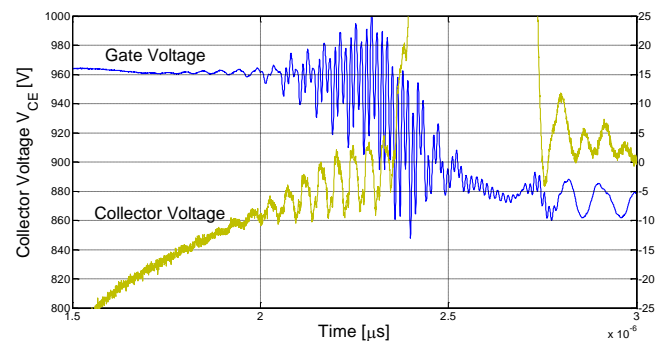

(b)

Fig. 6. Evidence of oscillations occurring during the short circuit test performed at collector voltage 900 V: (a) gate voltage, collector voltage/current waveforms, (b) details of the gate and collector oscillating waveforms.

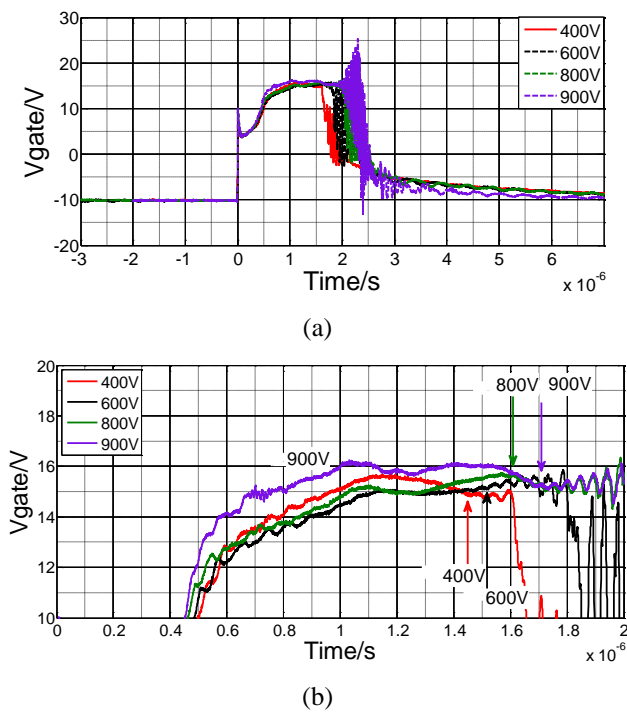

Fig. 7. Study of the oscillations' occurrence on the gate voltage at different collector-emitter voltage: (a) gate voltage waveforms obtained at increasing collector voltages from 400V to 900V, (b) details of the same waveforms before the IGBT turn-off from $t=0$ to $t=2 \mu s$.

collector voltages and, what's more, the amplitudes increase with the applied collector voltage. Figure 7(b) depicts the detail of the same waveforms from $t = 0$ to $t = 2 \mu s$. The oscillation beginnings are evidenced by arrows. It appears evident from Figure 7(b) that oscillations take place at times increasing with the applied voltage.

Based on the comprehensive tests, a relation between the oscillations and collector voltage can be achieved. Figure 8 illustrates the obtained relation between the oscillation beginning time and the applied voltage for the complete set of the performed experiments. A best fit line has also been calculated and included into the same picture, evidencing that the delay increases linearly with the applied voltage in a good approximation.

5. Conclusion

A non-destructive tester has been developed aimed to investigate short circuit behavior of IGBT power modules aimed to wind applications. Its main feature is to enable studying instabilities while protecting the device under test with a high time accuracy. Testing times are automatically controlled by FPGA hardware capable of a 10 ns time resolution.

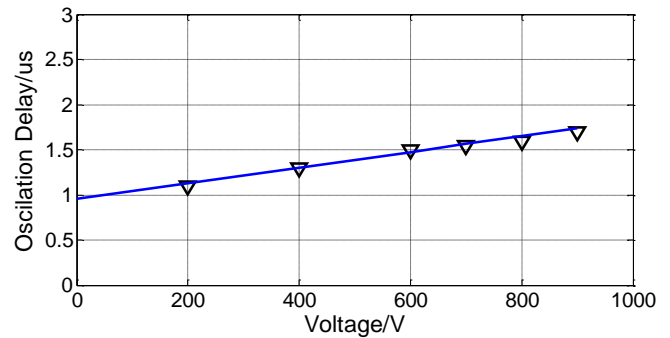

Fig. 8. Oscillation beginning delay versus collector voltage.

A comprehensive study has been performed on commercial IGBT power modules used in wind turbines applications to investigate the occurrence of unstable oscillations. As shown by the noticeable results, the oscillations occurring on the gate voltage are delayed at increasing applied collector voltages.

Acknowledgements

This work has been conducted at the Center of Reliable Power Electronics (CORPE, <http://www.corpe.et.aau.dk>), Aalborg University, Denmark.

References

- [1] H. Wang, M. Liserre, and F. Blaabjerg, "Toward reliable power electronics - challenges, design tools and opportunities," *IEEE Industrial Electronics Magazine*, vol. 7, no. 2, pp. 17-26, Jun. 2013.
- [2] Y. Song, B. Wang, "Survey on reliability of power electronic systems," *IEEE Transactions on Power Electronics*, vol.28, no.1, pp.591-604, Jan. 2013.
- [3] R. Wu, F. Blaabjerg, H. Wang, M. Liserre, and F. Iannuzzo, "Catastrophic failure and fault-tolerant design of IGBT power electronic converters - An overview," in *Proceedings of Annual Conference of the IEEE Industrial Electronics Society (IECON)*, pp.505-511, 2013.
- [4] H. Wang, M. Liserre, F. Blaabjerg, P. de Place Rikken, J. B. Jacobsen, T.kVisgaard, and J. Landkildehus "Transitioning to physics-of-failure as a reliability driver in power electronics", *IEEE Journal of Emerging and Selected Topics in Power Electronics*, vol.2, no.1, pp. 97-114, Mar. 2014
- [5] E. Wolfgang, "Examples for failures in power electronics systems," presented at *ECPE Tutorial on Reliability Power Electronic System*, Nuremberg, Germany, Apr. 2007.

- [6] S. Yang, A. T. Bryant, P. A. Mawby, D. Xiang, L. Ran, and P. Tavner, "An industry-based survey of reliability in power electronic converters," *IEEE Transactions on Industry Applications*, vol. 47, no. 3, pp.1441-1451, May/June. 2011.
- [7] F. Blaabjerg, K. Ma, "Future on power electronics for wind turbine systems", *IEEE Journal of Emerging and Selected Topics in Power Electronics*, vol.1, no.3, pp. 139-152, Sept. 2013.
- [8] F. Blaabjerg, M. Liserre, and K. Ma, "Power electronics converters for wind turbine systems," *IEEE Transactions on Industry Applications*, vol.48, no.2, pp.708-719, Mar./Apr. 2012.
- [9] J.L. Hudgins, "Power electronic devices in the future", *IEEE Journal of Emerging and Selected Topics in Power Electronics*, vol.1, no.1, pp. 11-17, Mar. 2013.
- [10]J. Lutz, U. Scheuermann, H. Schlangenotto, and R. de Doncker, "Semiconductor power devices," Springer: 2011, ISBN: 3642111246.
- [11]M. Ciappa, "Selected failure mechanisms of modern power modules," *Microelectronics Reliability*, vol. 42, no. 4-5, pp. 653-667, Apr./May. 2002.
- [12]S. Yang, D. Xiang, A. Bryant, P. Mawby, L. Ran, and P. Tavner, "Condition monitoring for device reliability in power electronic converters: a review," *IEEE Transactions on Power Electronics*, vol. 25, no. 11, pp. 2734-2752, Nov. 2010.
- [13]M. Arab, S. Lefebvre, Z. Khatir, and S. Bontemps, "Experimental investigations of trench field stop IGBT under repetitive short circuits operations," in *Proceedings of IEEE Power Electronics Specialists Conference (PESC)*, pp.4355-4360, 2008.
- [14]A. Castellazzi, M. Johnson, M. Piton, and M. Mermet-Guyennet, "Experimental analysis and modeling of multi-chip IGBT modules short circuit behavior," in *Proceedings of IEEE 6th International Power Electronics and Motion Control Conference (IPEMC)*, pp.285-290, 2009.
- [15]R. Wu, F. Iannuzzo, H. Wang, and F. Blaabjerg, "Fast and accurate Icepak-PSpice co-simulation of IGBTs under short-circuit with an advanced PSpice model", In *Proceedings of the 7th IET International Conference on Power Electronics, Machines and Drives (PEMD)*, pp.1-5, 2014.
- [16]R. Wu, F. Iannuzzo, H. Wang, and F. Blaabjerg, "An Icepak-PSpice Co-simulation Method to Study the Impact of Bond-wire Fatigue on the Current and Temperature Distribution of IGBT Modules under Short-circuit", *Accepted by 2014 IEEE Energy Conversion Congress and Exposition (ECCE)*, 2014.
- [17]F. Iannuzzo, "High Performance, FPGA-based Test Apparatus for Unclamped Inductive Switching of IGBTs", *Microelectronics Reliability*, vol.48, no. 8/9, pp. 1449-1452, Aug./Sept. 2008.
- [18]A. Ahmed, A. Castellazzi, L. Coulbeck, and M.C. Johnson, "Design and test of a high power IGBT non-destructive tester," *IEEE International Symposium on Industrial Electronics (ISIE)*, pp.292-297, 2012.
- [19]R. Wu, L. Smirnova, F. Iannuzzo, H. Wang, and F. Blaabjerg, "Investigation on the Short-circuit Behavior of an Aged IGBT Module through a 6 kA/1.1 kV Non-Destructive Testing Equipment", *Accepted by the 40th Annual Conference of the IEEE Industrial Electronics Society (IECON)*, 2014.
- [20]L. Smirnova, J. Pyrhönen, F. Iannuzzo, R. Wu, and F. Blaabjerg, "Round busbar concept for 30 nH, 1.7 kV, 10 kA IGBT non-destructive short-circuit tester", in *Proceedings of 16th European Conference on Power Electronics and Applications, (EPE'14 ECCE Europe)*, pp.1-9, 2014.

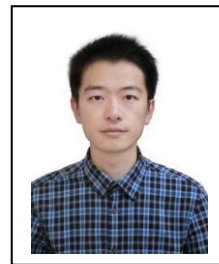

Rui Wu (PhD student)

Rui Wu received the B.Sc. degrees in electrical engineering from Huazhong University of Science and Technology, Wuhan, China, in 2009 and M.Sc. in Power Electronics from China Electric Power Research Institute, Beijing, China in 2012 respectively. He was employed at China Electric Power Research Institute in 2012. He is currently working toward the Ph.D. degree in the Department of Energy Technology, Aalborg University, Denmark.

His research interests are multi-physics modeling of power devices and power device's behavior during abnormal conditions, especially short circuits.

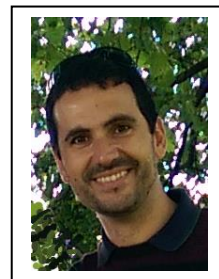

Francesco Iannuzzo (Professor)

Francesco Iannuzzo earned his Ph.D. degree in Electronics and Information Engineering from the University of Naples, Italy, in 2001, with a study on the reliability of power MOSFETs during diode operations. He is primarily specialized in the field of power

device modelling.

He is full professor of Reliable Power Electronics at the Aalborg University, Denmark, where he is also part of CORPE (Center of Reliable Power Electronics <http://www.corpe.et.aau.dk>). He is author or co-author of more than 90 publications on journals and international

conferences. His research interests are in the field of reliability of power devices, including against cosmic rays, power device failure modelling and development of non-destructive testing facilities for assessment of MW-scale power modules under extreme conditions.

Prof. Iannuzzo is a senior member of the IEEE (Reliability Society and Industrial Electronic Society) and of AEIT (Italian Electric, Electronic and Telecommunication Association).



Huai Wang (Assistant Professor)
Huai Wang received the B.Eng. degree in Electrical and Electronic Engineering from the Huazhong University of Science and Technology, Wuhan, China, in 2007, and the Ph.D. degree in Electronic Engineering from the City University of Hong Kong, Kowloon, Hong Kong, in 2012.

He has been with Aalborg University, Aalborg, Denmark, since 2012, where he is currently an Assistant Professor with the Department of Energy Technology. He is a Visiting Scientist with the ETH Zurich, Zurich, Switzerland, from August to September, 2014 and with the Massachusetts Institute of Technology (MIT), Cambridge, MA, USA, from September to November, 2013. He was with the ABB Corporate Research Center, Baden, Switzerland, in 2009. He has contributed over 20 journal papers and filed four patents. His current research interests include the reliability of DC-link and AC filter capacitors, reliability of power electronic systems, high voltage DC-DC power converters, time-domain control of converters, and passive components reduction technologies.

Dr. Wang is a recipient of the five paper awards and project awards from industry, IEEE, and the Hong Kong Institution of Engineers. He serves the Guest Associate Editor of the IEEE Transactions on Power Electronics Special Issue on Robust Design and Reliability in Power Electronics, and a Session Chair of various conferences in power electronics.



Frede Blaabjerg (Professor)
Frede Blaabjerg was with ABB-Scandia, Randers, Denmark, from 1987 to 1988. From 1988 to 1992, he was a Ph.D. Student with Aalborg University, Aalborg, Denmark. He became an Assistant Professor in 1992, an Associate

Professor in 1996, and a Full Professor of power electronics and drives in 1998. His current research interests include power electronics and its applications such as in wind turbines, PV systems, reliability, harmonics and adjustable

speed drives.

He has received 15 IEEE Prize Paper Awards, the IEEE PELS Distinguished Service Award in 2009, the EPE-PEMC Council Award in 2010, the IEEE William E. Newell Power Electronics Award 2014 and the Villum Kann Rasmussen Research Award 2014. He was an Editor-in-Chief of the IEEE TRANSACTIONS ON POWER ELECTRONICS from 2006 to 2012. He has been Distinguished Lecturer for the IEEE Power Electronics Society from 2005 to 2007 and for the IEEE Industry Applications Society from 2010 to 2011.