



Aalborg Universitet

AALBORG UNIVERSITY
DENMARK

Distributed Secondary Control in DC Microgrids with Low-Bandwidth Communication Link

Loh, Poh Chiang; Blåbjerg, Frede; Peyghami, Saeed; Mokhtari, Hossein

Published in:

Proceedings of 7th Power Electronics and Drive Systems Technologies Conference (PEDSTC), 2016

DOI (link to publication from Publisher):

[10.1109/PEDSTC.2016.7556935](https://doi.org/10.1109/PEDSTC.2016.7556935)

Publication date:

2016

Document Version

Accepted author manuscript, peer reviewed version

[Link to publication from Aalborg University](#)

Citation for published version (APA):

Loh, P. C., Blaabjerg, F., Peyghami, S., & Mokhtari, H. (2016). Distributed Secondary Control in DC Microgrids with Low-Bandwidth Communication Link. In Proceedings of 7th Power Electronics and Drive Systems Technologies Conference (PEDSTC), 2016: PEDSTC2016 (pp. 641 - 645). IEEE Press. <https://doi.org/10.1109/PEDSTC.2016.7556935>

General rights

Copyright and moral rights for the publications made accessible in the public portal are retained by the authors and/or other copyright owners and it is a condition of accessing publications that users recognise and abide by the legal requirements associated with these rights.

- ? Users may download and print one copy of any publication from the public portal for the purpose of private study or research.
- ? You may not further distribute the material or use it for any profit-making activity or commercial gain
- ? You may freely distribute the URL identifying the publication in the public portal ?

Take down policy

If you believe that this document breaches copyright please contact us at vbn@aub.aau.dk providing details, and we will remove access to the work immediately and investigate your claim.

Distributed Secondary Control in DC Microgrids with Low-Bandwidth Communication Link

Saeed Peyghami-Akhuleh, and Hossein Mokhtari
Dept. of Electrical Engineering
Sharif University of Technology
Tehran, Iran
saeed_peyghami@ee.sharif.edu, mokhtari@sharif.edu

Poh Chiang Loh, and Frede Blaabjerg
Dept. of Energy Technology
Aalborg University
Aalborg, Denmark
pcl@et.aau.dk, fbl@et.aau.dk

Abstract— In this paper, a distributed secondary power sharing approach with low bandwidth communication network is proposed for low voltage direct current (LVDC) microgrids. Conventional droop control causes voltage drop in the grid and also a mismatch on the current of converters in the case of consideration of the line resistances. Proposed control system carry out the current value of the other converters to reach the accurate current sharing and suitable voltage regulation as well. Voltage and current controllers locally regulate the voltage and current of converters as a secondary controller. Secondary controller is realized locally and the communication network is only used to transfer the data of dc currents. Therefore, the secondary controller can regulate the average voltage by only using the data of currents. The proposed approach is verified with simulations based on PLECS.

Keywords—secondary control, droop control, dc microgrid, distributed power sharing control

I. INTRODUCTION

The concept of ac/dc microgrids has been proposed in recent years [1], [2] to increase reliability, power quality and decrease losses and pollution. Both ac and dc power systems have been studied and implemented for years. However, due to the advances in the power electronics technology, dc-based power networks have been used in industrial applications such as data centers [3], space applications [4], offshore wind farms [5], ships [6], electric vehicles [7] and HVDC transmission systems [8]. Many power sources and loads, such as photovoltaic (PV) modules, fuel cell units, batteries, motor driven loads, and full converter based generators (i.e. micro-turbines and wind turbines) have a natural dc coupling [9]. Therefore, it is a more efficient and reliable method to integrate these sources and loads into a dc-based system by using dc-dc power electronic converters [10].

Power sharing control is a key issue in a stable and efficient operation of a microgrid. Many studies have been carried out to attain proper power management in ac and dc power systems at all three levels of the hierarchical control of a microgrid. In all of these studies, both tertiary and secondary control are done by communication links [11]–[14]. However, primary control is usually done with distributed droop methods.

The main objectives of the control system (primary and secondary) in a dc microgrid are voltage regulation at all buses and proportional load sharing among dispatchable sources

[15]–[19]. Despite the simplicity of implementation, conventional droop methods suffer from poor voltage regulation and load sharing, particularly when the line impedances are not negligible [20]–[22]. The primary reason for this poor voltage regulation is the voltage drop caused by the virtual impedance. Another factor is the output voltage mismatch among different converters, which is crucial for the natural power flow in the dc systems. Possible solutions to the aforementioned issues have been reviewed in [14]. These solutions are either centralized or require a communication network throughout the microgrid [23]. A centralized secondary control in [24] measures the microgrid voltage, calculates a voltage restoration term, and sends the restoration term to all sources. Decentralized secondary controllers also, require communication link to regulate the average voltage and also increase the current sharing among the converters [14]. Therefore, a complicated communication network is needed to transmit data of voltages and currents between converters. Moreover, the delay of the communication link for both current and voltage data transmission affects the stability.

In this paper, conventional droop method is used to control the current sharing of converters. A distributed secondary controller is proposed to compensate the voltage drop due to the droop gains and line resistances and also to eliminate the mismatch of currents dispatched between converters. A low-band width communication link is used to transfer the data of currents of converters and the secondary controller locally controls the voltage and current of each converter. The main advantage of the proposed controller is locally regulating the voltage and current of converters by only using the data of currents.

This paper is organized as follows. Section II explains the details of the power management system and the main idea of the proposed control system as a secondary controller. Small signal stability analysis is discussed in section III. Section IV presents the simulation results of the control scheme using PLECS. Finally, section VI summarizes the conclusions of this paper.

II. PROPOSED CONTROL APPROACH

Proposed distributed secondary control system includes in two controllers for current sharing and voltage restoring in microgrid. The control system and single line diagram of a typical microgrid is depicted in Fig. 1. Current Regulator

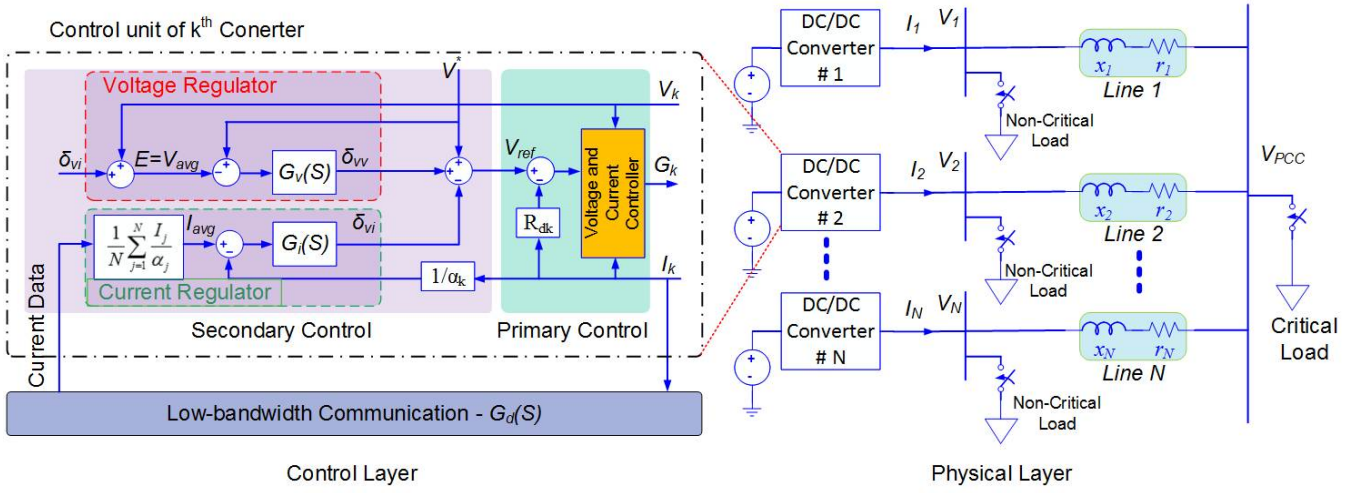

Fig. 1. Proposed control approach; Voltage Regulator G_v , Current Regulator G_i , and low-bandwidth communication link with delay function of $G_d(s) = \frac{1}{1 + \tau s}$.

is used to increase the accuracy of the dispatched current with conventional droop controller and Voltage Regulator restores the average voltage of the microgrid to the nominal value. Both regulators are described in the following.

A. Current Regulator

Current sharing among converters is conventionally performed by droop gain R_{dk} which can be defined as (1) for k^{th} converter.

$$R_{dk} = \frac{V_{max} - V_{min}}{I_{nk}} \quad (1)$$

where V_{max} and V_{min} is the maximum and minimum allowable voltage range and I_{nk} is the nominal current of k^{th} converter. However, because of the differences in line resistances, the currents are not proportionally dispatched among converters. The current regulator calculates the weighted average currents of all converters and tries to regulate the output current proportional to the nominal current of each converter. The average current (I_{avg}) can be calculated as (2).

$$I_{avg} = \frac{1}{N} \sum_{j=1}^N I_j / \alpha_j \quad j=1:N \quad (2)$$

where N is the number of converters, I_j is the measured current and α_j is the sharing coefficient of j^{th} converter respectively.

A simplified single line model of a dc microgrid with two converter is shown in Fig. 2. At steady state, droop gain acts as a series resistor (R_{d1} & R_{d2}). The secondary current regulator behaves as a small positive/negative resistor (r_{d1} & r_{d2}) such that the total resistance of each line becomes proportional to the rated current of each converter. Hence, the relation between rated current (I_{nj}) and sharing coefficient (α_j) and total line resistance between j^{th} converter and Point of Common Coupling (PCC) can be described as:

$$\frac{I_{ni}}{\alpha_i} = \frac{\alpha_j}{\alpha_i} = \frac{R_{dj} + r_{dj} + r_j}{R_{di} + r_{di} + r_i}; \quad i, j=1:N, i \neq j \quad (3)$$

where r_j is the resistance of the line connected to j^{th} converter.

Effect of current regulator in power sharing system is schematically described in Fig. 3. The blue graph shows the

effect of conventional droop gain. The secondary current regulator changes the slope of this droop characteristics to reach the same current between two converters. Sharing coefficients are assumed 1 for both converters. Therefore, the accurate current sharing is obtained with droop controller and current regulator. However, the average voltage through the microgrid is decreased and a distributed voltage regulator is required to restore the average voltage of the microgrid.

B. Voltage Regulator

This regulator compensates the voltage drop though the droop gain. From Fig. 2, the output voltage of each converter (V_1 & V_2) can be calculated as:

$$\begin{aligned} V_1 &= V_r - R_{d1}I_1 - \delta_{v1} \\ V_2 &= V_r - R_{d2}I_2 - \delta_{v2} \end{aligned} \quad (4)$$

where V_r is the reference value of the voltage loop. If sharing coefficients are assumed to be 1, then the droop gains have to be equal ($R_{d1}=R_{d2}=R_d$) and also, at steady states $I_1=I_2$. The output of the current regulators are:

$$\begin{aligned} \delta_{v1} &= \left(\frac{I_1 + I_2}{2} - I_1 \right) G_d G_i(s) = \left(\frac{I_2 - I_1}{2} \right) G_d G_i(s) \\ \delta_{v2} &= \left(\frac{I_1 + I_2}{2} - I_2 \right) G_d G_i(s) = \left(\frac{I_1 - I_2}{2} \right) G_d G_i(s) \end{aligned} \quad (5)$$

where $G_i(s)$ is the PI controller and $G_d(s)$ is the delay of communication link. At steady state $\delta_{v1} + \delta_{v2} = 0$. Therefore the average voltage of the microgrid is:

$$V_{avg} = \frac{1}{2}(V_1 + V_2) = V_r - R_d I \quad (6)$$

Applying primary droop controller and secondary current regulator causes average voltage drop equal to $R_d I$. From the single line model of the microgrid depicted in Fig. 2, internal voltages (i.e. E_1 & E_2) are equal to the average voltage calculated by (6). Therefore, the distributed voltage regulator can estimate the internal voltage and regulate it at the reference value. In fact, the correction term (δ_{vv}) shifts up the droop characteristics in Fig. 3 to restore the average voltage of the microgrid which can be calculated as (7), where V^* is the rated voltage of the microgrid.

$$\begin{aligned}\delta_{v1} &= (V^* - (V_1 + \delta_{v1}))G_v(s) \\ \delta_{v2} &= (V^* - (V_2 + \delta_{v2}))G_v(s)\end{aligned}\quad (7)$$

III. SMALL SIGNAL STABILITY

In this section, analysis of small signal stability of the simplified dc microgrid depicted in Fig. 2 is described. The relation between converter voltage and PCC voltage can be found as:

$$\begin{aligned}V_1 - V_{PCC} &= r_1 I_1 \\ V_2 - V_{PCC} &= r_2 I_2\end{aligned}\quad (8)$$

where

$$V_{PCC} = R_L (I_1 + I_2) \quad (9)$$

The set point value for primary controller is:

$$\begin{aligned}V_{ref1} &= V^* + \delta_{v1} - \delta_{vi1} \\ V_{ref2} &= V^* + \delta_{v2} - \delta_{vi2}\end{aligned}\quad (10)$$

And the set point value for the inner voltage loop can be determined by primary controller as:

$$\begin{aligned}V_1^* &= V_{ref1} - R_d I_1 \\ V_2^* &= V_{ref2} - R_d I_2\end{aligned}\quad (11)$$

Substituting (5), (7) and (10) in (8) gives:

$$\begin{aligned}V_1^* &= V^* - \delta_{v1} - \frac{R_d I_1}{1 + G_v(s)} \\ V_2^* &= V^* - \delta_{v2} - \frac{R_d I_2}{1 + G_v(s)}\end{aligned}\quad (12)$$

This equations show that the term of $R_d I$ which is related to the primary controller can be eliminated in low frequencies i.e. in the secondary controller frequency bandwidth. Therefore, primary controller tries to dispatch the current between converters based on droop gain and secondary controller tries to reduce the mismatch in current sharing as well as decrease the voltage drop because of the droop gain.

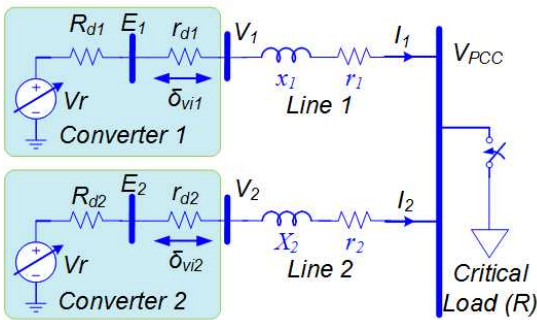

Fig. 2. Simplified model of 2-converter based dc microgrid.

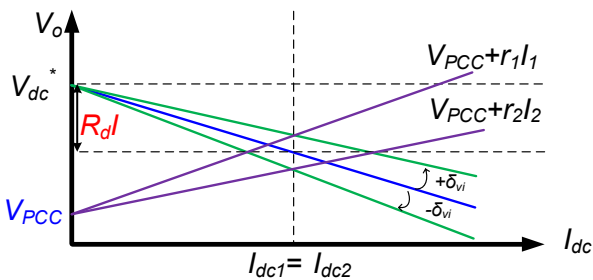

Fig. 3. Proposed droop characteristic adjustment.

Combining equations (5), (7), (8), (9) and (10) gives the system representation in state space as (13).

$$\begin{bmatrix} 0.5G_i G_d - \frac{R_d}{1 + G_v} - R_L - r_1 & -0.5G_i G_d - R_L \\ -0.5G_i G_d - R_L & 0.5G_i G_d - \frac{R_d}{1 + G_v} - R_L - r_2 \end{bmatrix} \begin{bmatrix} I_1 \\ I_2 \end{bmatrix} = \begin{bmatrix} -V^* \\ -V^* \end{bmatrix} \quad (13)$$

The zeros of this matrix determines the poles of the system. For a simple system described in TABLE I, the root loci are shown in Fig. 4. The inner voltage loop poles are faster than primary controller and secondary controller as well. Therefore, the primary controller regulates the output currents based on droop gains. After current sharing, secondary Current Regulator eliminates the small mismatches between currents. At the end, the secondary Voltage Regulator compensates the average voltage drop.

The effect of communication delay on dominant poles (i.e., primary and secondary poles) is shown in Fig. 5. Communication delay varies from 2 to 30 ms. The closed loop poles are located on the left half of the plane at different communication delay.

TABLE I. SPECIFICATIONS OF MICROGRID AND CONTROL SYSTEM

Definition	Symbol	Value
Impedance of line 1	$r_1(\Omega)/L_1(\mu H)$	0.5/600
Impedance of line 2	$r_2(\Omega)/L_2(\mu H)$	1-2/900
Rated current of Converters	$I_{n1}/I_{n2} (A)$	7/7
DC link voltage	$V_{dc} (V)$	700
Maximum Voltage Variation	$\Delta V (\%V)$	5% -35
Voltage-Current droop gain	$R_d (V/A)$	5
Loads	$R_L/R_{L2} (\Omega)$	100/100
Communication link delay	$\tau (ms)$	5
Current regulator	$G_i = k_{pi} + k_{iv}/s$	3+25/s
Voltage regulator	$G_v = k_{pv} + k_{iv}/s$	1.5+15/s

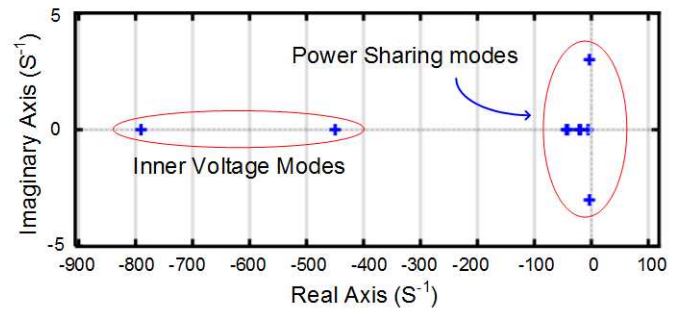

Fig. 4. Root loci of closed loop system, inner voltage loop poles, and Power Sharing controller poles. (Inner current controller poles are not shown.)

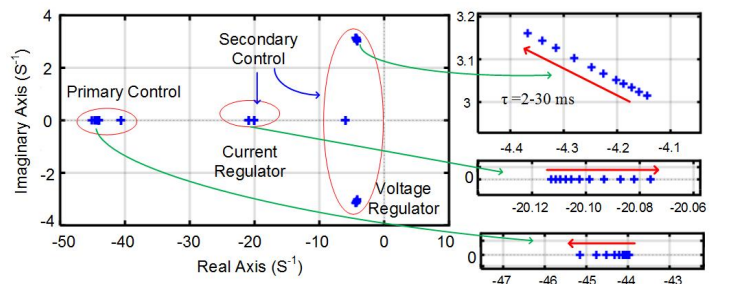

Fig. 5. Power sharing controller poles. Effect of communication delay (τ) on root loci is very small.

IV. SIMULATION RESULTS

A simplified dc microgrid with two converters like one in Fig. 2 is considered to validate the proposed control approach. The system parameters are given in TABLE I. Boost topology is selected for both dc converters with input voltage of 540 V and output voltage of 700 V. Each boost converter has $L=2mH$, $C=500\mu F$, switching frequency $f_s=20\text{ kHz}$.

In Case I, the performance of proposed control method is validated and compared to the conventional droop controller without secondary controller. In this case a different line resistance are considered as well. In Case II, the performance of proposed controller is demonstrated at different loading conditions. Voltage and current waveforms are exhibited the performance of the controller.

A. Case I: Comparison with Conventional Droop Method

In this case, the performance of the proposed controller is demonstrated in the considered microgrid in Fig. 2. The load of $100\ \Omega$ is connected to the PCC. At first, the conventional droop method controls the current and voltage of the converters. As depicted in Fig. 6, the currents are not equally dispatched between converters. However, after applying the secondary controller the output current of both converters are the same. Proposed controller regulates the average voltage of the microgrid at the nominal value (i.e. 700 V). As shown in Fig. 7, after applying the proposed controller, the average voltage – yellow one – is settled at 700 V. Load voltage is around 680 V with conventional droop method, however, after applying the proposed controller, it regulates at 697 V.

In order to demonstrate the further performance of the control system, different line resistances are considered. Here, r_1 is fixed at $0.5\ \Omega$ and r_2 is set to $1\ \Omega$ and $2\ \Omega$ respectively. The output current for both resistances are depicted in Fig. 6 and Fig. 8 respectively and also, the voltage of converters are shown in the Fig. 7 and Fig. 9 respectively. The equal current sharing and suitable voltage regulation is achieved with both resistances.

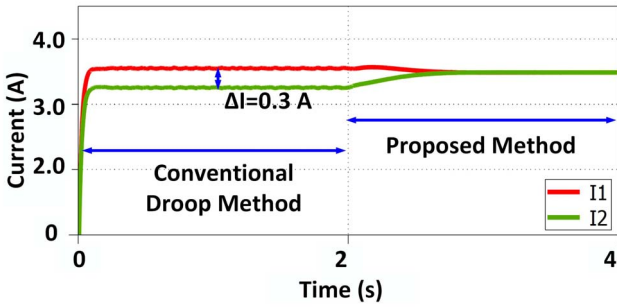

Fig. 6. DC current of converters with $r_1=0.5$ and $r_2=1\ \Omega$, applying proposed control causes accurate current sharing.

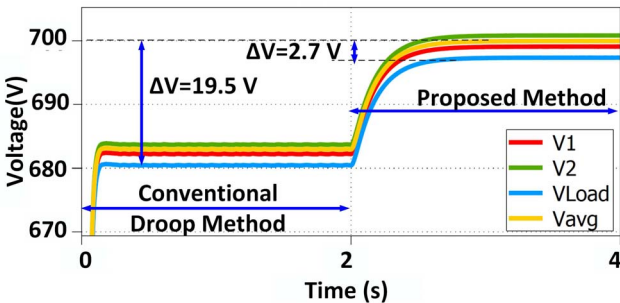

Fig. 7. DC voltage of converters with $r_1=0.5$ and $r_2=1\ \Omega$, applying proposed control regulates the average voltage of microgrid.

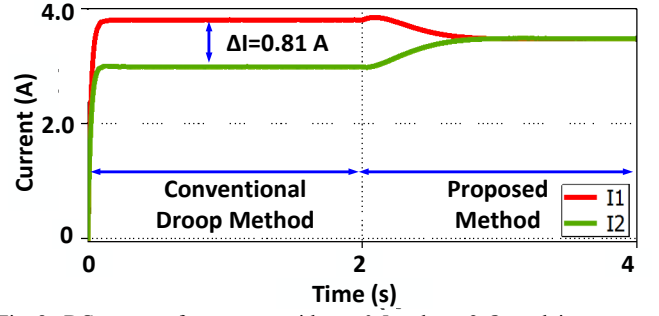

Fig. 8. DC current of converters with $r_1=0.5$ and $r_2=2\ \Omega$, applying proposed control causes accurate current sharing.

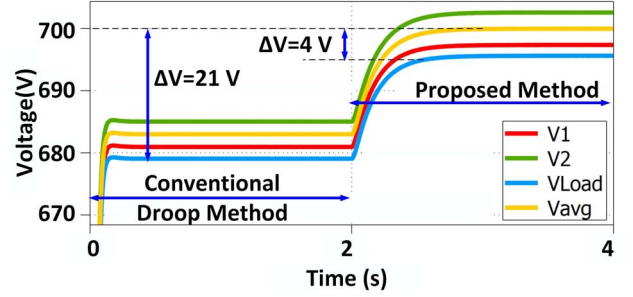

Fig. 9. DC voltage of converters with $r_1=0.5$ and $r_2=2\ \Omega$, applying proposed control regulates the average voltage of microgrid.

B. Case II: Different Loading Condition

In this case, the applicability of the proposed control system is demonstrated in different loading conditions. The resistive load of $100\ \Omega$ is connected into the PCC. At $t=2\text{ s}$ the other load with $100\ \Omega$ resistance is turned on and at $t=4\text{ s}$ is turned off. The current and voltage waveforms of both converters are shown in Fig. 10 and Fig. 11 respectively. The equal and accurate current sharing at both $100\ \Omega$ and $50\ \Omega$ loading conditions are achieved. The acceptable transient response of the secondary controller is obtained as well and the currents and voltages are settled at 0.5 second. The average voltage of the grid is regulated at the nominal value in both loading conditions. And load voltage deviation from the rated value is acceptable.

From the dc power flow theory, in case of no control on dc voltage, the currents have to be dispatched based on line resistances. Therefore, for the case with $r_1=0.5\ \Omega$ and $r_2=1\ \Omega$ the output current of first converter has to be 2 times more than the second one. However, all simulation results show that the primary controller dispatch the currents regarding to the droop gain and the secondary controller reduces the mismatch between currents and also restores the voltage drop as well.

The viability of the proposed control system at different line resistances and different loading conditions are represented by simulation results.

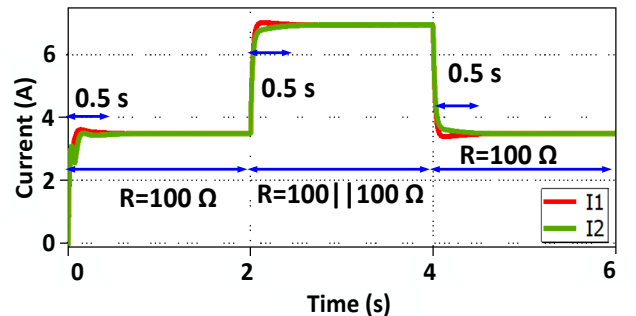

Fig. 10. DC current of converters with $r_1=0.5$ and $r_2=1\ \Omega$, at both loads of $100\ \Omega$ and $50\ \Omega$, accurate current sharing between converters is achieved.

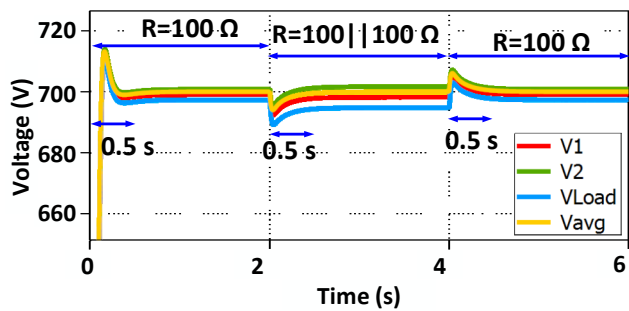

Fig. 11. DC voltage of converters with $r_1 = 0.5$ and $r_2 = 1 \Omega$, at both loads of 100Ω and 50Ω , proposed control can regulate the average voltage of microgrid at 0.5 second.

V. CONCLUSION

This paper has presented a reliable secondary control with low-bandwidth communication link for power management in LVDC microgrids to improve the voltage regulation and current sharing accuracy. Secondary control regulates the average voltage of microgrid and also, proportionally controls the output current of converters by carrying out the information of the other converter currents, without communicating the voltage information, and then, leads to increase of reliability. The viability of proposed control system is ensured for different line resistances and different loading condition. The proposed approach is verified by simulations based on PLECS. Future research will be focused on generalizing the proposed secondary control approach using the information of neighbor converters for multi converter microgrids.

References

- [1] F. Katiraei, R. Iravani, N. Hatziargyriou, and A. Dimeas, "Microgrids Management," *IEEE Power Energy Mag.*, vol. 6, no. 3, pp. 54–65, 2008.
- [2] N. Hatziargyriou, H. Asano, R. Iravani, and C. Marnay, "Microgrids," *IEEE Power Energy Mag.*, vol. 5, no. 4, pp. 78–94, 2007.
- [3] E. Alliance, "380 Vdc Architectures for the Modern Data Center," pp. 1–29, 2013.
- [4] S. P. Barave and B. H. Chowdhury, "Hybrid AC/DC Power Distribution Solution for Future Space Applications," *IEEE Power Eng. Soc. Gen. Meet.*, vol. 65401, 2007.
- [5] J. Robinson, D. Jovcic, and G. Joos, "Analysis and Design of an Offshore Wind Farm Using a MV DC Grid," *IEEE Trans. Power Del.*, vol. 25, no. 4, pp. 2164–2173, Oct. 2010.
- [6] J. G. Ciezki and R. W. Ashton, "Selection and Stability Issues Associated with a Navy Shipboard DC Zonal Electric Distribution System," *IEEE Trans. Power Del.*, vol. 15, no. 2, pp. 665–669, 2000.
- [7] C. C. Chan, "An Overview of Electric Vehicle Technology," in *Proc. IEEE*, vol. 81, no. 9, pp. 1202–1213, 1993.
- [8] N. G. Hingorani, "High-Voltage DC Transmission: A Power Electronics Workhorse," in *IEEE Spectr.*, vol. 33, no. 4, pp. 63–72, 1996.
- [9] D. Manz, R. Walling, N. Miller, B. LaRose, R. D'Aquila, and B. Daryanian, "The Grid of the Future: Ten Trends That Will Shape the Grid Over the Next Decade," *IEEE Power Energy Mag.*, vol. 12, no. 3, pp. 26–36, 2014.
- [10] M. E. Baran and N. R. Mahajan, "DC Distribution for Industrial Systems: Opportunities and Challenges," *IEEE Trans. Ind. Appl.*, vol. 39, no. 6, pp. 1596–1601, 2003.
- [11] T. Zhou and B. François, "Energy Management and Power Control of a Hybrid Active Wind Generator for Distributed Power Generation and Grid Integration," *IEEE Trans. Ind. Electron.*, vol. 58, no. 1, pp. 95–104, 2011.
- [12] J. Rocabert, A. Luna, F. Blaabjerg, and P. Rodriguez, "Control of Power Converters in AC Microgrids," *IEEE Trans. Power Electron.*, vol. 27, no. 11, pp. 4734–4749, 2012.
- [13] P. C. Loh and F. Blaabjerg, "Autonomous Control of Distributed Storages in Microgrids," in *Proc. IEEE ICPE-ECCE Asia*, pp. 536–542, 2011.
- [14] S. Anand, B. G. Fernandes, and J. M. Guerrero, "Distributed Control to Ensure Proportional Load Sharing and Improve Voltage Regulation in Low-Voltage DC Microgrids," *IEEE Trans. Power Electron.*, vol. 28, no. 4, pp. 1900–1913, 2013.
- [15] D. Chen, L. Xu, and L. Yao, "DC Voltage Variation Based Autonomous Control of DC Microgrids," *IEEE Trans. Power Del.*, vol. 28, no. 2, pp. 637–648, 2013.
- [16] X. Lu, K. Sun, J. M. Guerrero, J. C. Vasquez, and L. Huang, "State-of-Charge Balance Using Adaptive Droop Control for Distributed Energy Storage System in DC Microgrid Applications," *IEEE Trans. Ind. Electron.*, vol. 61, no. 6, pp. 2804–2815, 2014.
- [17] P. C. Loh, D. Li, Y. K. Chai, and F. Blaabjerg, "Autonomous Operation of Hybrid Microgrid with AC and DC Subgrids," *IEEE Trans. Power Electron.*, vol. 28, no. 5, pp. 2214–2223, 2013.
- [18] Y. Ito, Y. Zhongqing, and H. Akagi, "DC Microgrid Based Distribution Power Generation System," in *Proc. IEEE IPEMC*, vol. 3, pp. 1740–1745, 2004.
- [19] P. Frack, P. Mercado, M. Molina, E. Watanabe, R. De Doncker, and H. Stage, "Control-Strategy for Frequency Control in Autonomous Microgrids," *IEEE J. Emerg. Sel. Top. Power Electron.*, vol. 6777, no. c, pp. 1–1, 2015.
- [20] H. Nikkhajoei and R. Iravani, "Steady-State Model and Power Flow Analysis of Electronically-Coupled Distributed Resource Units," *IEEE Power Eng. Soc. Gen. Meet. PES*, vol. 22, no. 1, pp. 721–728, 2007.
- [21] Y. W. Li and C.-N. Kao, "An Accurate Power Control Strategy for Power-Electronics-Interfaced Distributed Generation Units Operating in a Low-Voltage Multibus Microgrid," *IEEE Trans. Power Electron.*, vol. 24, no. 12, pp. 2977–2988, Dec. 2009.
- [22] J. He and Y. W. Li, "Analysis, Design, and Implementation of Virtual Impedance for Power Electronics Interfaced Distributed Generation," *IEEE Trans. Ind. Appl.*, vol. 47, no. 6, pp. 2525–2538, 2011.
- [23] T. L. Vandoorn, S. Member, and B. Meersman, "A Control Strategy for Islanded Microgrids With DC-Link Voltage Control," *IEEE Trans. Power Del.*, vol. 26, no. 2, pp. 703–713, 2011.
- [24] J. M. Guerrero, J. C. Vasquez, J. Matas, L. G. De Vicuña, and M. Castilla, "Hierarchical Control of Droop-Controlled AC and DC Microgrids - A General Approach toward Standardization," *IEEE Trans. Ind. Electron.*, vol. 58, no. 1, pp. 158–172, 2011.