

Assessment Studies regarding the Optimal Sizing of Wind Integrated Hybrid Power Plants for Off-Grid Systems

Petersen, Lennart; Iov, Florin; Tarnowski, German Claudio; Carrejo, Carlos

Published in:
Proceedings of CIRED Workshop 2018

Publication date:
2018

Document Version
Early version, also known as pre-print

[Link to publication from Aalborg University](#)

Citation for published version (APA):
Petersen, L., Iov, F., Tarnowski, G. C., & Carrejo, C. (2018). Assessment Studies regarding the Optimal Sizing of Wind Integrated Hybrid Power Plants for Off-Grid Systems. In *Proceedings of CIRED Workshop 2018: CIRED Workshop on Microgrids and Local Energy Communities* (pp. 1-4). Article 0078 CIRED.
[http://www.cired.net/publications/workshop2018/pdfs/Submission%200078%20-%20Paper%20\(ID-20788\).pdf](http://www.cired.net/publications/workshop2018/pdfs/Submission%200078%20-%20Paper%20(ID-20788).pdf)

General rights

Copyright and moral rights for the publications made accessible in the public portal are retained by the authors and/or other copyright owners and it is a condition of accessing publications that users recognise and abide by the legal requirements associated with these rights.

- Users may download and print one copy of any publication from the public portal for the purpose of private study or research.
- You may not further distribute the material or use it for any profit-making activity or commercial gain
- You may freely distribute the URL identifying the publication in the public portal -

Take down policy

If you believe that this document breaches copyright please contact us at vbn@aub.aau.dk providing details, and we will remove access to the work immediately and investigate your claim.

ASSESSMENT STUDIES REGARDING THE OPTIMAL SIZING OF WIND INTEGRATED HYBRID POWER PLANTS FOR OFF-GRID SYSTEMS

Lennart PETERSEN
Aalborg University – Denmark
Vestas Wind Systems – Denmark
lep@et.aau.dk

Florin IOV
Aalborg University
– Denmark
fi@et.aau.dk

German C. TARNOWSKI
Vestas Wind Systems
– Denmark
getar@vestas.com

Carlos CARREJO
Vestas Wind Systems
– Denmark
cecgo@vestas.com

ABSTRACT

The paper focusses on the optimal sizing of off-grid hybrid power plants including wind power generation. A modular and scalable system topology as well as an optimal sizing algorithm for the HPP has been presented in a previous publication. In this paper, the sizing process is evaluated by means of assessment studies. The aim is to address the impact of renewable resource data, the required power supply availability and reactive power load demand on the optimal sizing of wind integrated off-grid HPPs.

INTRODUCTION

This paper covers the topic off-grid systems, i.e. isolated microgrids, being preferred in remote locations (islands, regions with low population density, secluded industrial sites) in order to prevent investments in the electricity transmission system. It is generally proven to be a cost effective approach for providing energy to off-grid consumers by combining multiple distributed energy resources (DERs), e.g. wind turbines (WTGs), photovoltaic (PV) and battery energy storage systems (BESSs). The aim of deploying these so-called off-grid hybrid power plants (HPPs) is to reduce the dependency on fossil-fueled production systems (i.e. diesel generator) which are still required during adverse environmental conditions (low or no wind or solar irradiation), albeit they require logistics, storage and availability of expensive fuels.

One important issue for off-grid HPPs is the sizing problem which involves the installed capacities of individual DERs and generic system management strategies according to the power demand and desired security of supply level [1]. Plenty of research has been devoted to these techno-economic analyses to determine the optimal component sizing. However, none of the studies has paid special attention to HPPs including wind power.

Some papers study the impact of the system reliability on the optimal system configuration [2], [3]. In reference [2], the power reliability criterion of FLNS - the fraction of total load that cannot be served - is considered as decision variable for the sizing problem. The off-grid HPP in reference [3] is evaluated by the loss of power supply probability (LPSP) and the optimal configuration is chosen based on a compromise between minimum LPSP and minimum LCOE. Such reliability criterion has been taken up by the IEC 62257 standard to categorize the supply quality indicators of decentralized rural electrification systems by means of specified supply availability per year (e.g. 95 %, 98 %, 99 %) [4]. In reference [5], it is ascertained that the LCOE continually decreases by relaxing the power reliability criterion. However, it is to be investigated whether such conclusion is valid for wind integrated HPPs.

Then the quality of the input data, i.e. load demand pattern and renewable generation resource data, plays an important role for the correct plant configuration, as access to demand profiles is limited e.g. in developing countries and collecting site specific data for wind speed and solar irradiation can be costly and time consuming. One publication [6] addresses the effect of load profile deviations on optimum sizing of off-grid PV systems, but does not consider the variations of renewable resource profiles, which is crucial particularly including the extremely intermittent wind resource. Most of the studies perform solely an energy analysis by representing active power generation vs. demand. Another important issue is the supply of reactive power demand to the demand subsystem, which has an effect on the HPP configuration according to the studies in [5] due to the reactive power ratings of the individual DERs. This aspect is not considered in most techno-economic analyses, mainly due to the omission of the system electrical infrastructure. The aim of this paper is to address the impact of 1. renewable resource data, 2. required power supply availability and 3. reactive power load demand on the optimal sizing of wind integrated off-grid HPPs. First, a modular and scalable system topology and the optimal sizing algorithm for the off-grid HPP are presented based on the elaborations in another paper of the same authors [7]. Subsequently, three test cases are discussed in order to evaluate the optimal sizing of wind integrated off-grid HPPs.

MODULAR AND SCALABLE SYSTEM TOPOLOGY

In [7] a modular and scalable system architecture for the HPP is proposed as per Figure 1.

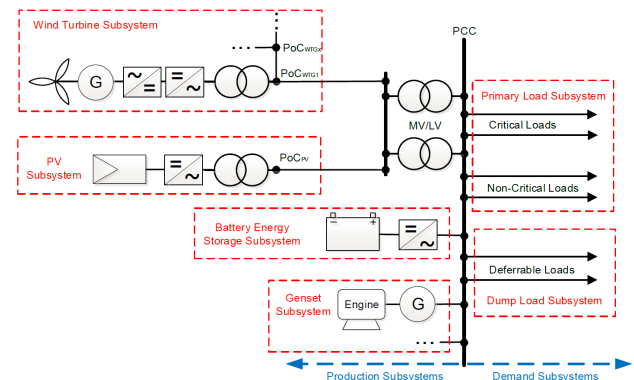

Figure 1: Generic SLD of the hybrid power plant architecture [7]

The primary load subsystem consisting of numerous feeders with critical and non-critical consumers is represented as an aggregated electrical load that the HPP shall meet in order to avoid power shortage. The dump load subsystem

represents the excess electricity produced by the DERs, which can be used for deferrable consumption.

All DERs are grid-connected on the AC side in order to enable the HPP to be designed and expanded with standardized components on a flexible and modular basis [8]. Due to spacious constraints and natural resource requirements, it is expected that WTG and PV subsystems are remotely located and interconnected via overhead lines or cables. It is shown in [7] that MV lines are required in order to account for power losses and voltage drops between production subsystem and PCC, if the power infeed is more than 70 kW and the lines longer than 250 meters. As for instance a 6.6 kV level will enable distances up to 4 km, even for high power infeed levels of up to 900 kW [7].

OPTIMAL SIZING ALGORITHM

The algorithm for determining the optimal sizes of the DERs within the HPP follows an enumeration-based single-objective optimization approach. In the first step annual profiles of load demand and renewable resources (wind speed, solar irradiation) are collected or synthesized. Subsequently, the balance of P & Q demand vs. P & Q supply is calculated during each time step of a whole year, based on hourly mean values, however taking into account the intra-hour power variations as proposed in [7]. In the next step, economic parameters (i.e. CAPEX, OPEX, replacement and salvage) are applied in order to calculate the LCOE of the HPP by extrapolating the annual calculation to the entire project lifetime. The subsystem and economic models are described in [7]. The LCOE is calculated as the average cost per kWh of useful electrical energy produced by the system. The decision variables of the optimization algorithm relate to the component ratings, i.e. rated WTG power $P_{WTG, rat}$ rated PV power $P_{PV, rat}$, rated BESS capacity $E_{BESS, rat}$, rated BESS converter power $P_{BESS-con, rat}$, number of gensets n_{GS} , rated power $P_{GS, rat}$ of the n-th genset and the substation transformer rating $S_{TR, rat}$. The decision variable vector is expressed as

$$\mathbf{X} = \begin{bmatrix} P_{WTG, rat} & P_{PV, rat} & E_{BESS, rat} \\ P_{BESS-con, rat} & n_{GS} & P_{GS, rat} & S_{TR, rat} \end{bmatrix} \quad (1)$$

The optimization problem is formulated such as to minimize the LCOE, subject to the constraints of

$$\begin{aligned} LPSP &\leq LPSP_{max} \\ \mathbf{X} &\leq \chi \end{aligned} \quad (2)$$

where χ is the feasibility region of the decision variables and the LPSP is the probability of insufficient power supply for the present load demand and is expressed by the sum of time when the HPP is not able to supply the load demand vs. the total observed time (e.g. one year)

$$LPSP = \frac{\sum_{t=1}^T \{\Delta t_f \text{ for } (P_s(t) < P_{PL}(t)) \text{ or } (Q_s(t) < Q_{PL}(t))\}}{E_{PL, served}} \quad (3)$$

where T , Δt_f , P_s , Q_s , P_{PL} and Q_{PL} are the total observed time period (one year), the time period of power failure, the supplied active and reactive power as well as the active and reactive power demand of the primary load subsystem, respectively.

TEST CASES

An exemplary load demand profile of a rural community including residential, commercial (e.g. enterprises, mobile charging stations, kiosks, school, pharmacy) and small industrial consumers (e.g. grain mills, repair shops) is applied and historical data for renewable resources from a site in Kenya/Africa with high wind conditions are used in this study for optimally sizing the off-grid HPP.

1. Renewable Resource Data

Concerning the renewable resource data, i.e. wind speed and solar irradiation, it can be expected that wind and solar yield is subject to annual variations. However, generally the sizing algorithms employ only one exemplary annual data set that shall represent the HPP performance over numerous years to determine the project costs. Figure 2 illustrates the problem when it comes to selecting data sets for wind speed and solar irradiation profile. The average RES production per kW installed WTG and PV is shown for 16 consecutive years. While the solar yield is relatively constant, the wind power production varies quite significantly with approximately $\pm 20\%$. The most representative data set is found in year 4 with a deviation of $\Delta E_{WTG, 1kW} = -2\%$ related to the mean value.

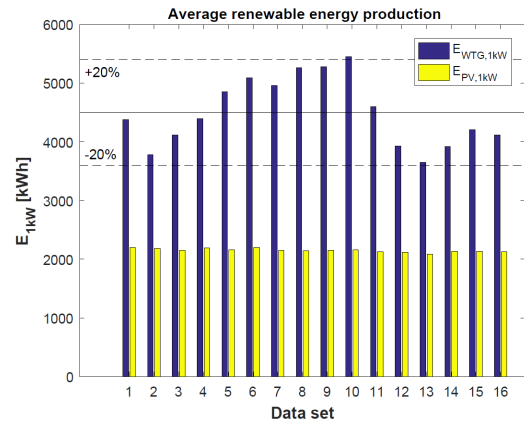

Figure 2: Average renewable energy production per kW installed WTG and PV for various annual data sets

During this test case, the robustness of the sizing algorithm is tested against various sets of renewable resource data. The goal is to obtain a high level of confidence for selecting the optimal system configuration by using the most representative data set. The optimal system configurations yielding lowest LCOE are computed for each data set and the results are shown in Figure 3. The y-axis presents all LCOE values which spread around $\pm 10\%$ about the mean. It is remarkable that the average data set #4 results in an LCOE being closest to the mean value ($\Delta LCOE = -0.5\%$). The x-axis depicts the power ratings of WTG and PV in kW as well as the energy rating of BESS subsystem in kWh. The BESS power rating (90 kW) and genset subsystem (3 x 30 kW) remain unchanged during each scenario, as being designed to meet the peak load demand [7]. The simulations result in five cost optimized system configurations as indicated by different bar colors (blue, red, green, yellow, magenta). However, one benchmark system configuration involving 80 kW WTG, 40 kW PV and 160 kWh BESS is obtained in 50% of the cases, including the representative

data set #4 (colored blue). Hence, this test case reveals that using a data set with average wind energy production provides a high level of confidence for obtaining the optimal system configuration and a representative cost value.

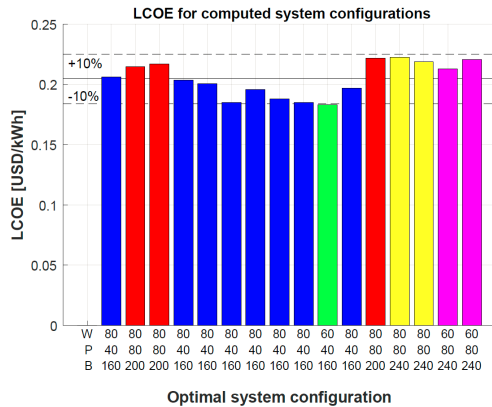

Figure 3: Simulation results for test case #1 (W = WTG rated power, P = PV rated power, B = Battery energy capacity)

2. Power Supply Availability

One supply quality criterion being suggested by the IEC standard for rural electrification systems [4] is the power supply availability (or vice versa LPSP) in %/year. The 100 % requirement is crucial for critical (emergency) loads, however unavailable access to power supply in time periods of adverse climate conditions (low or no wind or solar irradiation) may be acceptable for non-critical loads (possibly sheddable). In this section, the sizing algorithm is applied to find the optimal system configuration for various power supply availability levels in order to test the coherence between LCOE and LPSP. The considered levels for maximum permitted LPSP are commonly in the range between $0\% \leq LPSP_{max} \leq 5\%$ [4]. The sizing algorithm is simulated for different $LPSP_{max}$ constraints and the respective computed system configurations leading to lowest LCOE are presented in Figure 4. The upper plot shows the LPSP obtained during HPP operation and the lower plot depicts the resulting LCOE of the HPP.

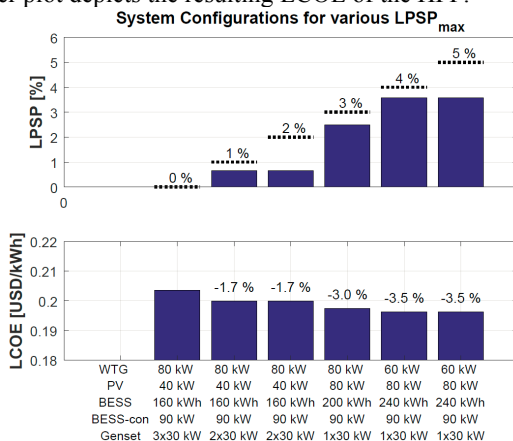

Figure 4: Results for test case #2: System configurations for various LPSP criteria

It can be remarked that the lower the supply availability requirement, the lower the required size of the genset subsystem. While 100 % supply availability requires three

30 kW gensets as a full backup to cover the load demand in every hour of the year, only 2/3 of the total genset capacity is sufficient to ensure power supply availability in 99 % of the time and only one 30 kW genset will ensure power reliability of 97 %. The cost impact is quantifiable by means of lower CAPEX and OPEX. However, reducing the genset subsystem implicates an augmentation of the remaining production subsystems, particularly BESS, in order to supply the load demand. In this study case, the cost of the optimal system configuration can be reduced by max. 3.5 % by relaxing the supply availability requirement (Figure 4). It needs to be emphasized that the results are obtained for one particular set of resource data, evaluated as being representative (see previous test case). In Figure 5 it is illustrated how the actual LPSP may change during the years. Using various historical data sets for renewable resource data, the values of LPSP are shown for each system configuration in Figure 4. The results reveal that the LPSP criterion is fulfilled in the majority of the cases, however in 44 % of the cases the maximum limit is exceeded. Hence, it remains questionable whether the HPP sizing process shall account for a relaxed LPSP constraint to minimize the overall system costs. The methodology is valid, if the present LPSP was evaluated as an average value throughout the entire project lifetime, but invalid, if the evaluation was performed on an annual basis.

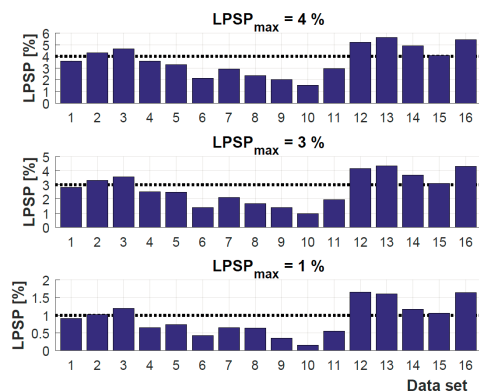

Figure 5: Results for test case #2: LPSP for various data sets

3. Reactive Power Demand

In the previous test cases the focus has been laid on energy supply, i.e. active power, to the loads. The corresponding results for any $LPSP > 0\%$ have indicated active power shortage in all cases. In contrast, reactive power shortage has not been observed so far. This means, sufficient reactive power capability by the DER is available to fulfill the load demand. However, it needs to be emphasized that reactive power demand highly depends on the present types of consumers in the community. Residential consumers include electrical appliances with both low power factor $\cos\theta < 0.8$ (e.g. lamps, fans, fridges) and high power factor $\cos\theta > 0.8$ (e.g. phone chargers, radio, TV). In the commercial sector some customers e.g. supermarkets may have a high share of inductive loads (air conditioning, freezers, fridges). Small industrial consumers usually include a number of induction motors with very low power factor down to $\cos\theta = 0.5$ (e.g. workshops, grain mills etc.). In the consumer scenario used during the previous test cases,

the share of industrial loads amounts to approximately 30 %. In this particular test case, it is investigated whether the configured HPP is able to provide sufficient reactive power to a consumer portfolio with higher share of loads with low power factor, i.e. 60 %, 80 % and 100 % respectively.

The sizing algorithm is applied to determine the cost optimal HPP configuration and the results for the obtained LPSP and the present reactive power shortage are shown in Table 1.

Table 1: Results for test case #3: LPSP and Q shortage

Share of loads with low power factor	> 30 %	> 60 %	> 80 %	> 100 %
LPSP [%]	0.00	0.02	0.06	0.08
Q shortage [h/year]	0	2	5	7

It can be remarked that the LPSP and the number of hours with present reactive power shortage rise with increasing share of loads with low power factor. The quantitative numbers are still relatively low. However, it is worth mentioning that in practical these numbers will be higher, as additional reactive power will be consumed along the distribution feeders to the individual consumers, being neglected in this study. In fact, there is an increasing risk for system instability due to the lack of available reactive power resources in the HPP, which is demonstrated in Figure 6. On the left hand side the reactive power shortage is shown for different shares of loads with low power factor. On the right hand side the remaining reactive power availability of BESS converter is presented.

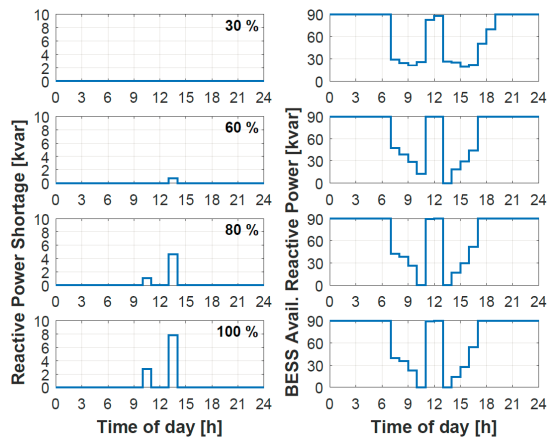

Figure 6: Q shortage (left) and remaining available Q of BESS (right) for various shares of loads with low power factor

It is noteworthy that critical events with insufficient reactive power supply occur only, when all gensets are out of operation. In this case, the WTG and PV subsystem provide a large share of the reactive power demand and the BESS converter takes over the remaining amount required. In Figure 6 it is clearly recognisable that available reactive power capacity of BESS converter is shrinking, the more inductive loads are present in the system. Eventually, the demand cannot be fulfilled as seen during time slots between 10 - 11 h and 13 - 14 h, so that reactive power shortage occurs. Hence, this test case demonstrates that reactive power demand needs to be taken into account when configuring the ratings of the DERs within the HPP. One way to avoid events of reactive power shortage is to increase the converter ratings of WTG and/or PV and/or BESS. In this test case it is assumed that the converter apparent power

rating is equal to the rated active power output in order to avoid component oversizing [7]. Alternatively, the scheduling of gensets can account for the anticipated reactive power demand in order to serve as a backup during critical scenarios, however leading to increased OPEX.

CONCLUSION

This paper has presented some assessment studies regarding the optimal sizing of wind integrated off-grid HPPs. The results have shown that selecting a representative annual data set of renewable resources (i.e. average wind energy production) is crucial for the system design to be valid for the entire project lifetime. With regard to the supply quality indicators proposed by technical standards, it remains questionable whether the HPP sizing process shall account for a specified level of power supply probability (e.g. 95 %) in order to minimize the overall system costs, as it seems challenging to fulfill such criterion due to the volatile nature of renewable energy production throughout the years. It has been observed that the present types of loads in the HPP affect the decision of whether reactive power demand needs to be regarded during the sizing process. A high share of inductive loads (> 30 %) with low power factor ($\cos\theta = 0.5 - 0.8$) may result in events of reactive power shortage. All in all, it is recommended that the reactive power demand shall be taken into account when configuring the ratings of the DERs within the HPP.

ACKNOWLEDGEMENT

This work was carried out as part of the PhD project "Proof-of-Concept on Next Generation Hybrid Power Plant Control". The authors acknowledge Innovation Fund Denmark for financial support through the Industrial PhD funding scheme.

REFERENCES

- [1] H. Lin, C. Liu, J. M. Guerrero, J. C. Vasquez, and T. Dragicevic, "Modular Power Architectures for Microgrid Clusters," in *International Conference on Green Energy (ICGE)*, 2014.
- [2] I. Sansa, R. Villafañilla, and N. M. Belaaç, "Optimal sizing design of an isolated microgrid based on the compromise between the reliability system and the minimal cost," in *16th International Conference on Sciences and Techniques of Automatic Control and Computer Engineering, STA 2015*, 2016, pp. 715–721.
- [3] A. Puri, "Optimally sizing battery storage and renewable energy sources on an off-grid facility," in *IEEE Power and Energy Society General Meeting*, 2013, pp. 1–5.
- [4] IEC 62257, "Recommendations for renewable energy and hybrid systems for rural electrification - Part 2: From requirements to a range of electrification systems," 2016.
- [5] F. A. Bhuiyan, "Optimal Sizing and Power Management Strategies of Islanded Microgrids for Remote Electrification Systems," University of Western Ontario, Canada, 2014.
- [6] S. Mandelli, C. Brivio, E. Colombo, and M. Merlo, "Effect of load profile uncertainty on the optimum sizing of off-grid PV systems for rural electrification," *Sustain. Energy Technol. Assessments*, vol. 18, pp. 34–47, Dec. 2016.
- [7] L. Petersen, F. Iov, G. C. Tarnowski, and C. Carrejo, "Optimal and Modular Configuration of Wind Integrated Hybrid Power Plants for Off-Grid Systems," in *3rd International Hybrid Power Systems Workshop*, 2018.
- [8] SMA, *Solar Stand-Alone Power and Backup Power Supply*. Juwi Solar GmbH, 2009.