



AALBORG UNIVERSITY
DENMARK

Aalborg Universitet

Thermal Plumes in Ventilated Rooms

an experimental research work

Kofoed, Peter; Nielsen, Peter V.

Publication date:
1988

Document Version
Publisher's PDF, also known as Version of record

[Link to publication from Aalborg University](#)

Citation for published version (APA):

Kofoed, P., & Nielsen, P. V. (1988). *Thermal Plumes in Ventilated Rooms: an experimental research work*. Dept. of Building Technology and Structural Engineering, Aalborg University. Indoor Environmental Technology Vol. R8833 No. 7

General rights

Copyright and moral rights for the publications made accessible in the public portal are retained by the authors and/or other copyright owners and it is a condition of accessing publications that users recognise and abide by the legal requirements associated with these rights.

- Users may download and print one copy of any publication from the public portal for the purpose of private study or research.
- You may not further distribute the material or use it for any profit-making activity or commercial gain
- You may freely distribute the URL identifying the publication in the public portal -

Take down policy

If you believe that this document breaches copyright please contact us at vbn@aub.aau.dk providing details, and we will remove access to the work immediately and investigate your claim.

INSTITUTTET FOR BYGNINGSTEKNIK

INSTITUTE OF BUILDING TECHNOLOGY AND STRUCTURAL ENGINEERING

AALBORG UNIVERSITETSCENTER · AUC · AALBORG · DANMARK

**INDOOR ENVIRONMENTAL TECHNOLOGY
PAPER NO. 7**

**Presented at the 3rd Seminar on »Application of Fluid Mechanics in Environmental Protection
-88», Silesian Technical University, Gliwice, Poland**

PETER KOFOED, PETER V. NIELSEN

THERMAL PLUMES IN VENTILATED ROOMS - An Experimental Research Work

NOVEMBER 1988

ISSN 0902-7513 R8833

The papers on INDOOR ENVIRONMENTAL TECHNOLOGY are issued for early dissemination of research results from the Indoor Environmental Technology Group at the University of Aalborg. These papers are generally submitted to scientific meetings, conferences or journals and should therefore not be widely distributed. Whenever possible reference should be given to the final publications (proceedings, journals, etc.) and not to the paper in this series.

INSTITUTTET FOR BYGNINGSTEKNIK
INSTITUTE OF BUILDING TECHNOLOGY AND STRUCTURAL ENGINEERING
AALBORG UNIVERSITETSCENTER · AUC · AALBORG · DANMARK

INDOOR ENVIRONMENTAL TECHNOLOGY
PAPER NO. 7

Presented at the 3rd Seminar on »Application of Fluid Mechanics in Environmental Protection
-88«, Silesian Technical University, Gliwice, Poland

PETER KOFOED, PETER V. NIELSEN
THERMAL PLUMES IN VENTILATED ROOMS - An Experimental Research Work
NOVEMBER 1988

ISSN 0902-7513 R8833

THERMAL PLUMES IN VENTILATED ROOMS
an experimental research work

Peter Kofoed, University of Aalborg, Denmark
Peter V. Nielsen, University of Aalborg, Denmark

INTRODUCTION

Ventilation systems with vertical displacement flow have been used in industrial areas with extensive heat loads for many years. Hot and contaminant air is carried directly from the occupied zone towards the ceiling by hot processes and other activities which create a natural convection flow as shown in fig. 1.

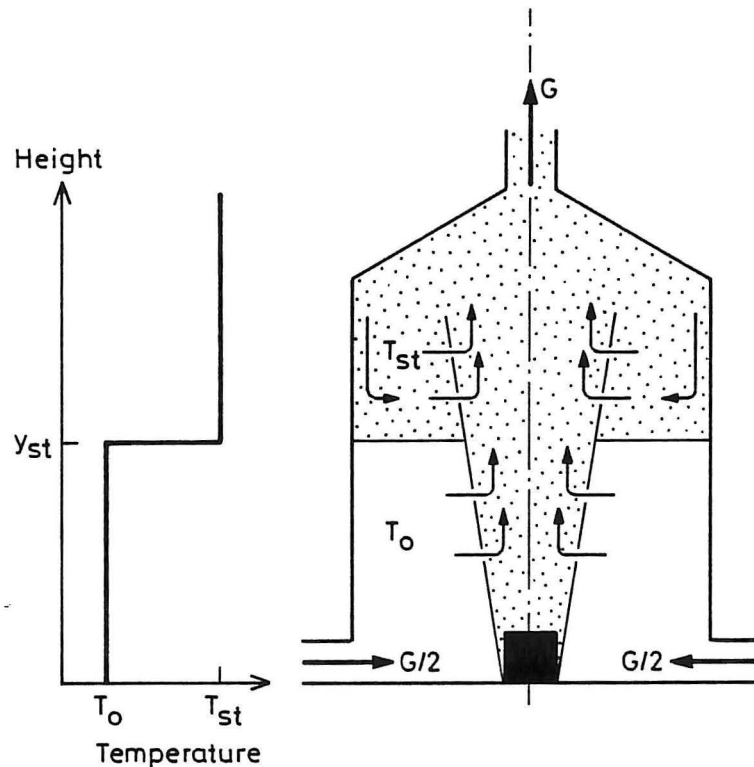

Fig. 1. Vertical displacement flow in an industrial area with a hot process. The primary air is supplied in the occupied zone and it is entrained in the hot plume up to a height y_{st} where the flow is equal to the air flow G supplied. A recirculation flow of hot air appears above the height y_{st} . The graph to the left shows an idealized picture of the vertical temperature distribution with the temperature T_0 in the occupied zone and T_{st} in the hot zone.

Quite recently the vertical displacement flow systems have grown popular as comfort ventilation in rooms with heat loads e.g. office rooms. The plumes from hot surfaces, from equipment located at different heights and from persons, together with draught from cold surfaces, make a rather complicated situation as shown in fig. 2, ref. (1).

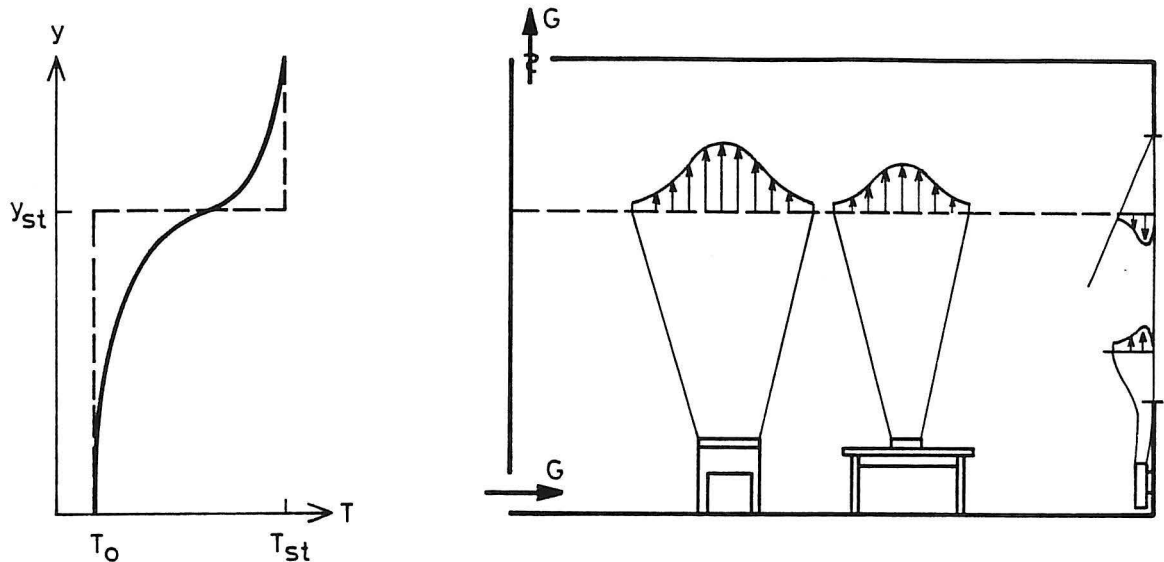

Fig. 2. Vertical displacement flow in an office room. The primary air is supplied in the occupied zone and is entrained in the hot plumes from the heat sources and in the cold draught. Dependent on the air flow supplied and the vertical air flow in the room there must be a certain height y_{st} at which the upward moving air flow is equal to the supplied air flow. The graph to the left shows the vertical temperature gradient which is a result of the interaction between the different plumes.

The displacement flow systems have two advantages compared with traditional mixing systems.

- An efficient use of energy. It is possible to remove exhaust air from the room where the temperature is several degrees above the temperature in the occupied zone which allows a higher air inlet temperature at the same load.
- An appropriate distribution of contaminant air. The vertical temperature gradient (or stratification) implies that fresh air and contaminant air are separated. The most contaminant air can be found above the occupied zone and the air flow supplied can be reduced.

DESIGN

The design of a displacement ventilation system involves determination of the flow rate in the thermal plumes. A reasonable supply air quantity G is then chosen so that the height y_{st} of the fresh air is above the head level.

Baturin (2) states the equations (1) to (4) describing the axi-symmetrical thermal plume over a concentrated heat source. The equations are based on Schmidt's relations for velocity and temperature over a point heat source, ref. (3). The flow in the plume is a fully developed turbulent flow for a height exceeding $2d$, and it is described by:

$$v_y = 0.13 Q^{1/3} (y+d)^{-1/3} \quad (1)$$

$$\Delta T_y = 0.45 Q^{2/3} (y+d)^{-5/3} \quad (2)$$

$$G = 0.005 Q^{1/3} (y+d)^{5/3} \quad (3)$$

$$w = 0.44 (y+d) \quad (4)$$

v_y	maximum velocity	(m/s)
ΔT_y	maximum temperature	(K)
G	air volume flow	(m ³ /s)
w	width of the velocity profile	(m)
y	vertical distance from heat source	(m)
d	diameter of heat source	(m)
Q	convective heat emission	(W)

The virtual origin of the flow is located at a distance d below the heat source.

This paper describes measurements on plumes in areas with vertical temperature gradients, which are common for displacement flow, see fig. 2. It will also describe the flow from different heat source geometries and the influence from wall surfaces on the entrainment in the plumes. All the above conditions are normally not taken into consideration in the design of a displacement flow system and they cannot be expressed by the equations (1) to (4), ref. (4) and ref. (5).

MEASUREMENTS AND DISCUSSION

Thermal plumes above different heat sources have been investigated by measuring velocity and temperature distributions in the plumes, by measuring the vertical temperature gradient in the surrounding air and by measuring the heat load.

The following heat sources have been used:

Circular plate	d = 112.8 mm	A = 0.010 m ²
	d = 225.7 mm	A = 0.040 m ²
	d = 356.8 mm	A = 0.100 m ²
Circular tube	d = 100 mm	A = 0.008 m ²

All the circular plates are silver-coated and they are placed horizontally in alu-covered mineral wool. The relation between convection and radiation is dependent on source type, size and temperature. The silver-coated horizontal plates emit roughly 90% of the heat by convection, while the tube emits a lower quantity by convection. The two types of heat sources are shown in fig. 3.

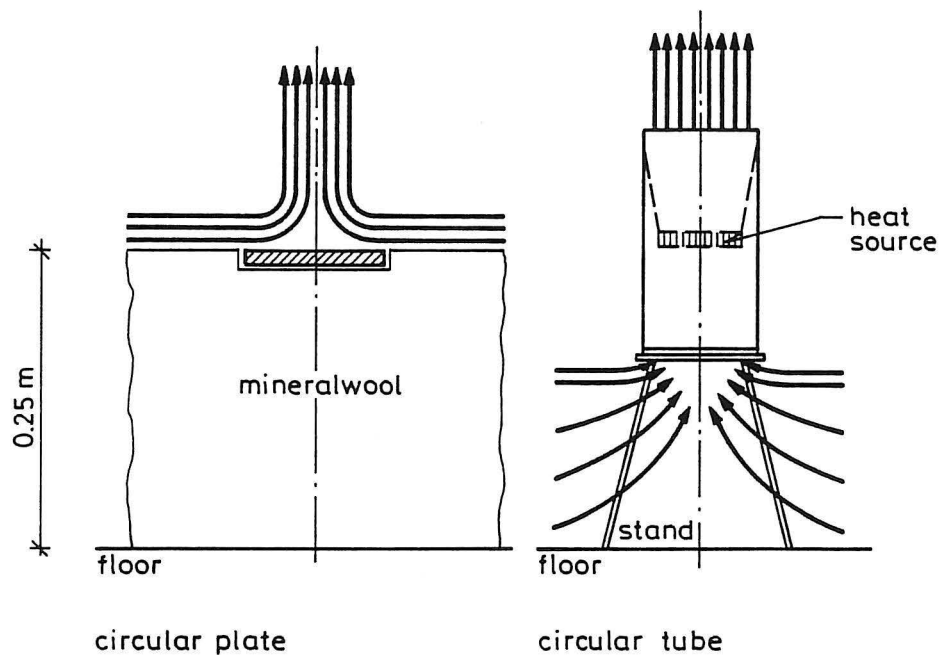

Fig. 3. The different heat sources and the surrounding flow.

VERTICAL TEMPERATURE GRADIENT

During these measurements the vertical temperature gradient dT/dy in the surrounding air has varied in the range between 0.09 and 0.27 K/m. Three experiments with the same heat source and heat load but with different gradients have been carried out. The velocity is described by an equation of the type $v_y \sim (y+d)^\alpha$ where α has the values as shown in table 1:

dT/dy (K/m)	α
0.09	-0.33
0.15	-0.51
0.27	-0.64

Table 1.

The influence of the temperature gradient dT/dy on the velocity v is not as significant as the influence on the power α in table 1. In the results described later the temperature gradient dT/dy has values of approximately 0.2 K/m.

JET WIDTH

In all experiments the width w increases at a higher rate than expected, as can be seen from fig. 4.

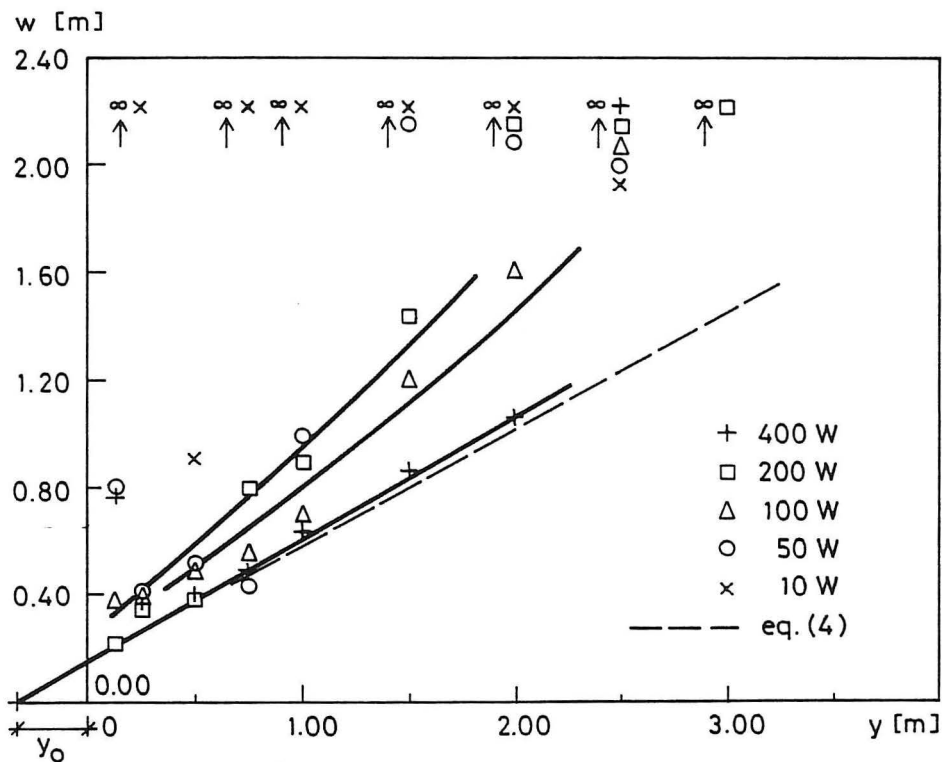

Fig. 4. The width w as a function of the distance y from the heat source. Circular plate $d = 356.8$ mm.

Equation (4) shows that the increase of the width w is directly proportional to the distance from the virtual origin of the plume which can also be seen from fig. 4. The straight line in the figure shows the locations of the virtual origins and the distance y_0 . The measurements show an increasing growth of the plume width w for $y > \approx 1.0$ m which indicates horizontal flow and disintegration of the vertical plume.

VELOCITY

The measured velocities are smaller than expected in all experiments, which is shown in fig. 5 and fig. 6. The figures show three typical areas: An acceleration area, an area with a velocity decay of the type $v_y \sim (y+y_0)^\alpha$, and an area with disintegrating tendencies, (a) y (b) and (c) in fig. 5 and fig. 6.

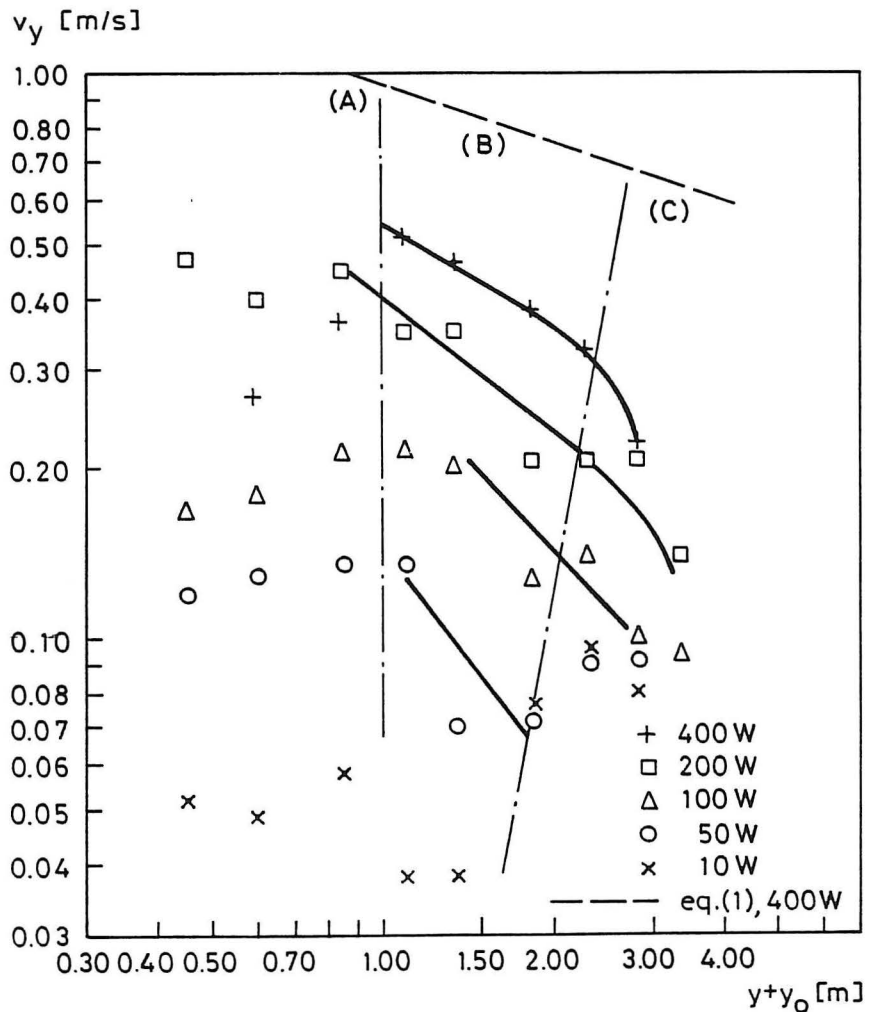

Fig. 5. Maximum velocity v_y in plume versus distance $y+y_0$. Circular plate $d = 356.8$ mm.

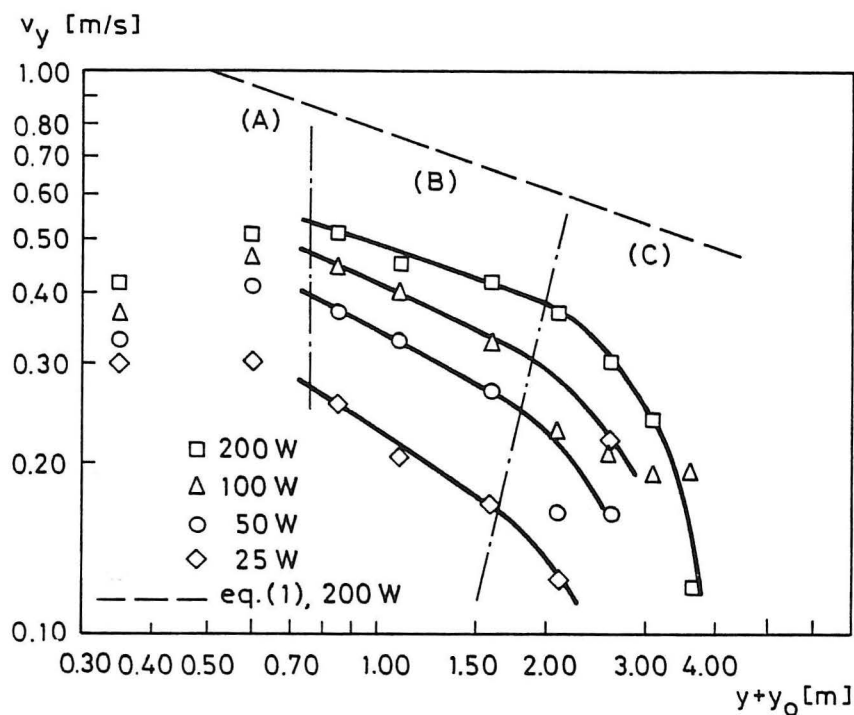

Fig. 6. Maximum velocity v_y in plume versus distance $y+y_0$. Circular tube $d = 100$ mm.

According to equation (1) the velocity v_y should decrease with the distance $y+d$ at the power $-1/3$ and the measurements show the following power α , table 2.

Heat source	Heat load Q (W)	Vert. temp. grad. dT/dy (K/m)	Power α
Circ. plate $d = 356.8$ mm	10	0.21	$-\infty$
	50	0.21	-1.33
	100	0.21	-0.98
	200	0.09	-0.85
	400	0.10	-0.60
Circ. tube $d = 100$ mm	25	0.20	-0.63
	50	0.15	-0.52
	100	0.15	-0.37
	200	0.15	-0.33

Table 2.

Table 2 shows that an increase in the heat load will reduce the numerical value of the power α and the theoretical value of -0.33 is obtained for the tube at high heat loads. It is further seen from fig. 5 and fig. 6 and from table 2 that the heat source geometry is of great importance in the description of the thermal flow.

VELOCITY PROFILE

The velocity profile can be described as a Gaussian error function in areas with similar turbulent flow, ref. (4) and (5).

$$\frac{v}{v_y} = \exp\left(\frac{-16 \ln 2}{w^2} y^2\right) \quad (5)$$

The measurements show that similarity between the profiles exists in the area where the width w is proportional to the distance $y+y_0$ and the velocity v_y is proportional to $(y+y_0)^\alpha$.

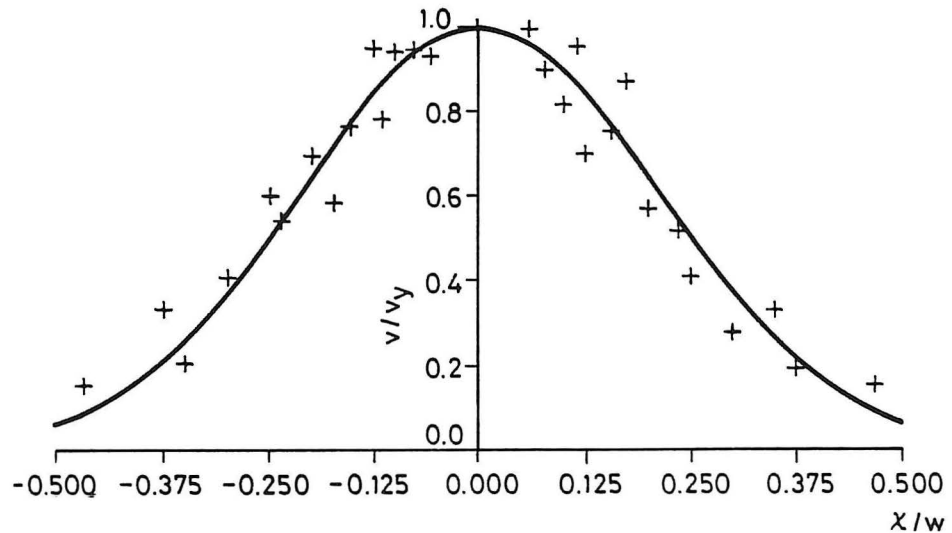

Fig. 7. Normalized velocity profile.

Fig. 7 shows a typical example of the velocity profile and the measurements in the area with similar turbulent flow.

VOLUME FLOW

The volume flow G in the plume is found as the volume of the rotational Gaussian error function:

$$G = 0.22 \cdot 10^{-3} w^2 v_y \quad (6)$$

G volume flow (m³/s)

w width (m)

V_y maximum velocity (m/s)

The volume flow G is calculated from the plume width w and the velocity v_y, and fig. 8 gives an example:

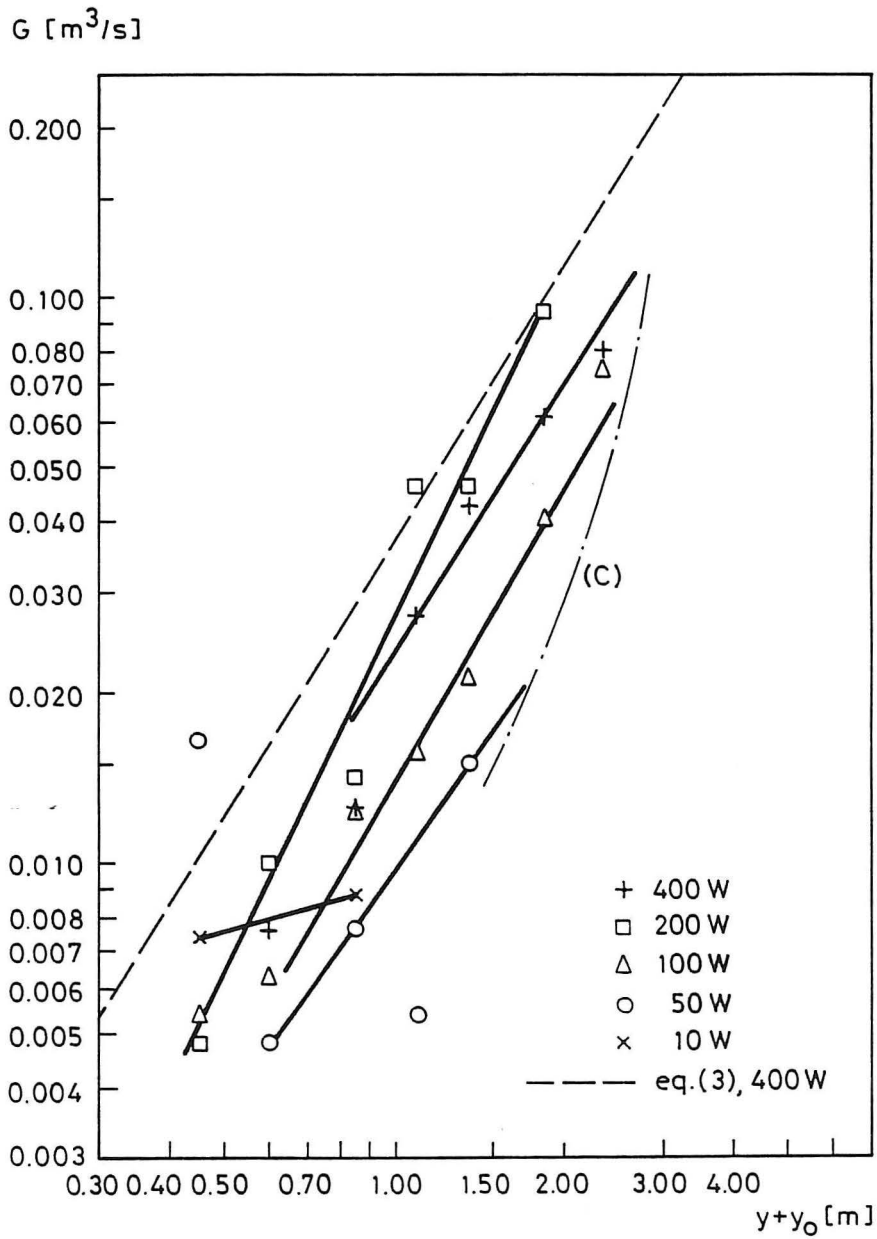

Fig. 8. The volume flow G as a function of the distance y+y₀. Circular plate d = 356.8 mm.

The power $5/3$ is observed in most cases. The volume flow G is in many cases equal to the values found in equation (3) although width and velocity in the plume are larger and smaller, respectively, than the values found from equations (1) and (4).

The vertical temperature gradient will disintegrate the plume at a certain height as indicated in the fig. 8, area (c).

TEMPERATURE DIFFERENCE

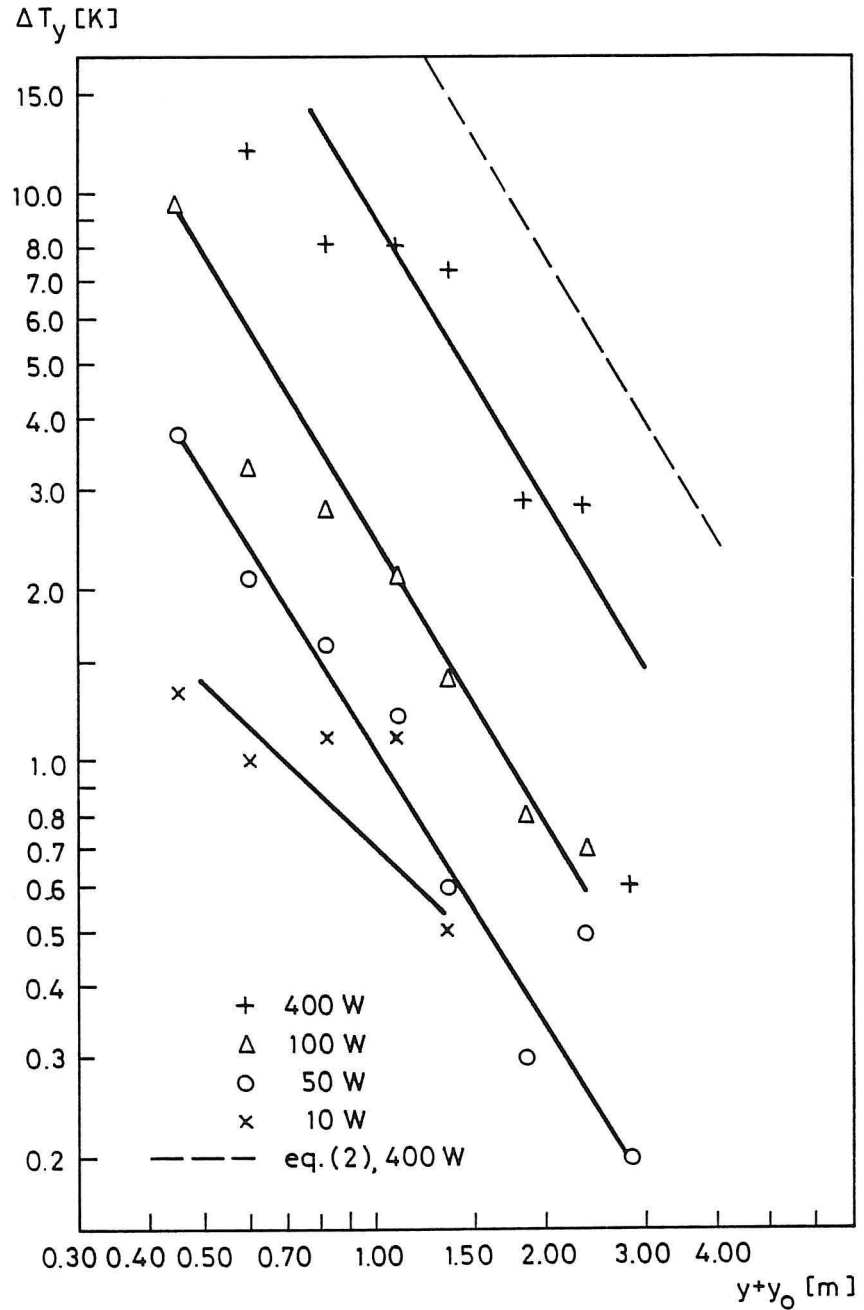

Fig. 9. Temperature difference ΔT_y versus distance $y+y_0$. Circular plate $d = 356.8$ mm.

Fig. 9 shows some measurements of the temperature difference ΔT_y . All the measured temperatures are small compared to equation (2), but the power $-5/3$ is obtained in most cases.

LOCAL ARCHIMEDES NUMBER

A local Archimedes number Ar_y may describe the flow in the plume.

$$Ar_y = \frac{gw\Delta T_y}{v_y^2 T_{sur}} \quad (7)$$

g gravity

w width

ΔT_y temperature difference: $\Delta T_y = T_y - T_{sur}$

T_y maximum temperature in the plume

T_{sur} temperature of the surrounding air

v_y maximum velocity

It has been observed by smoke experiments that the vertical flow becomes horizontal in some cases due to temperature stratification. Measurements show that the vertical flow leaves the area with similarity at the same value of the local Archimedes number $Ar_y \approx 1.0$ and it is fully horizontal at $Ar_y \approx 0.0$ because ΔT_y will be equal to 0.0 at that height.

ENTRAINMENT IN PLUMES CLOSE TO WALLS

The entrainment in a thermal plume can be influenced by the surrounding walls. Two experiments have been carried out to illustrate this. In the first experiment the heat source is placed close to a vertical wall surface so that a kind of wall-jet appears, in the second experiment the heat source is placed in a corner between two vertical wall surfaces. The measurements are carried out with a high thermal load ($Q = 500$ W) from the most concentrated heat source (tube $d = 100$ mm) to reduce the influence by the vertical temperature gradient.

Fig. 10 shows the measured results for three situations. The volume flow G increases with the distance $y+y_0$ at the power $5/3$ and the entrainment is reduced to 70% when the heat source is placed close to a single wall. It is reduced to 60% when the heat source is placed in a corner.

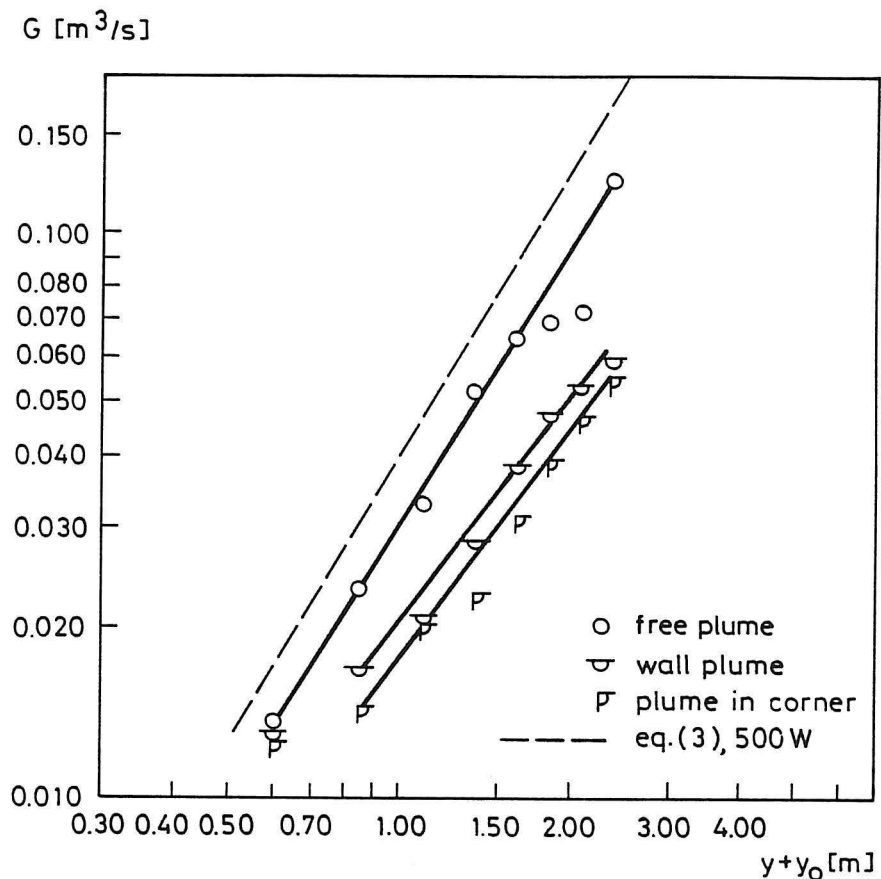

Fig. 10. The volume flow G versus the distance $y+y_0$ in a free plume, in a plume located close to a single wall, and in a plume located in a corner between two walls.

CONCLUSION

The traditional equation system for thermal plumes (eqs. 1 to 4) does not take the vertical temperature gradient in the surroundings, the heat source geometry and the location of the heat source close to walls into account.

The measurements show that the plume width increases at a higher rate, the velocity decreases faster and is less influenced by the convective heat emission compared to the results from eq. 1 and eq. 4. The measured volume flow in the plume will in many cases be equal to the values from equation 3 but the vertical temperature gradient may dissolve the plume in a certain height.

The experiments with circular plates and circular tubes show that the heat source geometry is decisive for the thermal flow. The flow from the tube is more stable than the one from the plates at the same heat emission.

It is a general conclusion that equations 1 to 4 can be regarded to be valid in the border-line case with a concentrated heat source and a large heat emission.

The entrainment in the thermal plume is influenced by the surrounding walls. Compared to a free plume the entrainment is reduced to 70% close to a single wall and to 60% when the heat source is placed in a corner.

In several cases it is observed that the similar turbulent flow in the plume disintegrates at a constant local Archimedes number.

REFERENCES

- (1) Skåret, E., Displacement ventilation, Room Vent 87, International conference on air distribution in ventilated spaces, Stockholm, 1987.
- (2) Baturin, V.V., Fundamentals of Industrial Ventilation, Pergamon Press, 1972.
- (3) Schmidt, W., Turbulente Ausbreitung eines Stromes erhitzter Luft, Z. angew. Math. Mech., Bd. 21, Nr. 5 & 6, Oktober & Dezember 1941.
- (4) Popiolek, Z., Problems of Testing and Mathematical Modelling of Plumes above Human Body and other Extensive Heat Sources, A4 - series., Inst. för Uppvärmnings- och ventilationsteknik, KTH, Stockholm.
- (5) Mierzwinski, S. & Popiolek, Z., Experimental Verification and Possibilities of Application of a Plume Model above a Point Heat Source, A4- series, No. 58, KTH, Stockholm.

APPENDIX

FLOW VISUALIZATION WITH SMOKE

Vertical displacement flow as shown in figure 2, page 2, implies a recirculating flow above a certain height y_{st} if the quantity of entrained air in the hot plume exceeds the quantity of air flow supplied. This has been observed by smoke measurements where smoke is injected continuously in the hot plume from a single heat source. The air is supplied by a single wall-mounted diffuser near the floor and it is exhausted through an opening in the ceiling.

After a while the smoke is stabilized below the ceiling due to the recirculating flow. The lower part of the room corresponds to the location of the occupied zone and it is clean except for the smoke in the hot plume, see also figure 1.

The height y_s from the heat source up to the zone with recirculating flow is measured as $y_s = y_{st} - 0,25$, because the heat source is placed 0,25 m above the floor. The vertical temperature gradient dT/dy is also measured. dT/dy is determined from temperature values in the occupied zone from the height 0,10 m above the floor and up to the height y_s above the heat source. In this way the vertical temperature gradient is only related to the lower area in the room without recirculation flow. The vertical temperature gradient dT/dy can be controlled by the air flow supply and the inlet temperature. A single 500 W tube heat source was used. The heat source was placed in various positions - free, close to a single wall or in a corner between two walls - to determine the influence on the height y_s by the location of the heat source.

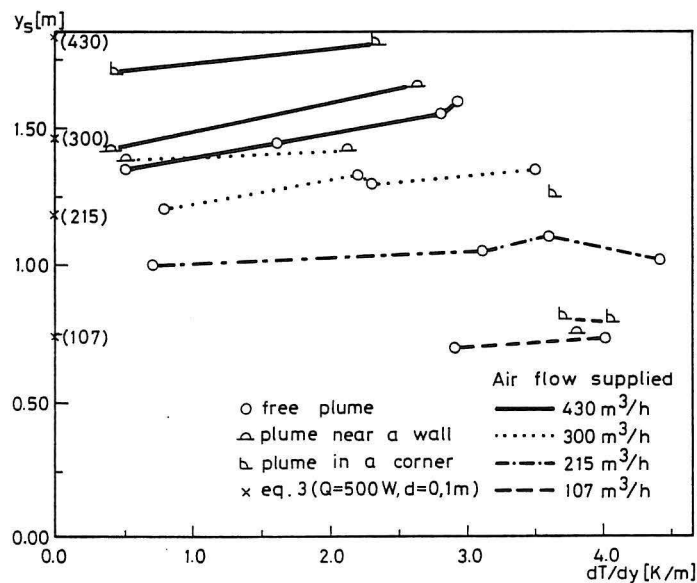

Fig. A1. The height y_s versus the vertical temperature gradient dT/dy for different heat source locations and air flow supplies.

Figure A1 shows that the location of the heat source in relation to the surrounding walls has an influence on the height y_s . When the plume is in a corner, the height y_s is at a maximum and the entrainment at a minimum followed by the wall plume and the free plume. The air flow supplied determines the height y_s which increases when the air flow supply is increased. The vertical temperature gradient dT/dy does not influence the height y_s significantly.

The height y_s cannot be regarded only as a measure of the entrainment in the hot plume, because there may be a cold downdraught near the walls as a result of the higher temperature in the recirculating zone. The cold downdraught implies that smoke from the recirculating zone moves along the walls and later on moves horizontally into the lower zone, which has the effect that this zone is expanded.

PAPERS ON INDOOR ENVIRONMENTAL TECHNOLOGY

PAPER NO. 1: C. E. Hyldgård: *Aerodynamic Control of Exhaust*. ISSN 0902-7513 R8712.

PAPER NO. 2: Per Heiselberg, Peter V. Nielsen: *The Contaminant Distribution in a Ventilated Room with Different Air Terminal Devices*. ISSN 0902-7513 R8713.

PAPER NO. 3: Peter V. Nielsen, L. Evensen, Peter Grabau, J. H. Thulesen-Dahl: *Air Distribution in Rooms with Ceiling-Mounted Obstacles and Three-Dimensional Flow*. ISSN 0902-7513 R8714.

PAPER NO. 4: Peter V. Nielsen, Åke T. A. Möller: *Measurements on Buoyant Wall Jet Flows in Air-Conditioned Rooms*. ISSN 0902-7513 R8715.

PAPER NO. 5: Peter V. Nielsen: *Numerical Prediction of Air Distribution in Rooms. Status and Potentials*. ISSN 0902-7513 R8823.

PAPER NO. 6: Peter V. Nielsen, Åke T. Möller: *Measurements on Buoyant Jet Flows from a Ceiling-Mounted Slot Diffuser*. ISSN 0902-7513 R8832.

PAPER NO. 7: Peter Kofoed, Peter V. Nielsen: *Thermal Plumes in Ventilated Rooms - An Experimental Research Work*. ISSN 0902-7513 R8833.

PAPER NO. 8: Peter V. Nielsen, Lars Hoff, Lars Germann Pedersen: *Displacement Ventilation by Different Types of Diffusers*. ISSN 0902-7513 R8834.

PAPER NO. 9: Per Heiselberg, Peter V. Nielsen: *Flow Conditions in a Mechanically Ventilated Room with a Convective Heat Source*. ISSN 0902-7513 R8835.

PAPER NO. 10: Peter V. Nielsen: *Displacement Ventilation in a Room with Low-Level Diffusers*. ISSN 0902-7513 R8836.

**INSTITUTE OF BUILDING TECHNOLOGY AND STRUCTURAL
ENGINEERING**

THE UNIVERSITY OF AALBORG

SOHNGAARDSHOLMSVEJ 57, DK-9000 AALBORG

TELEPHONE: + 45 8 14 23 33

TELEFAX: + 45 8 14 82 43

TELEX: 69523