



AALBORG UNIVERSITY
DENMARK

Aalborg Universitet

Papers, volume 5 - 1997-2000

Thoft-Christensen, Palle

Publication date:
2006

Document Version
Publisher's PDF, also known as Version of record

[Link to publication from Aalborg University](#)

Citation for published version (APA):
Thoft-Christensen, P. (2006). *Papers, volume 5 - 1997-2000*. Aalborg Universitetsforlag.

General rights

Copyright and moral rights for the publications made accessible in the public portal are retained by the authors and/or other copyright owners and it is a condition of accessing publications that users recognise and abide by the legal requirements associated with these rights.

- Users may download and print one copy of any publication from the public portal for the purpose of private study or research.
- You may not further distribute the material or use it for any profit-making activity or commercial gain
- You may freely distribute the URL identifying the publication in the public portal -

Take down policy

If you believe that this document breaches copyright please contact us at vbn@aub.aau.dk providing details, and we will remove access to the work immediately and investigate your claim.

CHAPTER 89

RELIABILITY ASSESSMENT OF CONCRETE BRIDGES¹

P. Thoft-Christensen* & C.R. Middleton**

*CSR, Aalborg, Denmark

**University of Cambridge, Cambridge, UK

1. INTRODUCTION

This paper is based on research performed for the Highways Agency, London, UK under the project DPU/9/44 "*Revision of Bridge Assessment Rules Based on Whole Life Performance: Concrete Bridges*". It contains details of a methodology which can be used to generate Whole Life (WL) reliability profiles. These WL reliability profiles may be used to establish revised rules for Concrete Bridges. The paper is to some extent based on Thoft-Christensen et al. [1], [2] and Thoft-Christensen [3].

2. BACKGROUND

Throughout the world highway authorities are faced with the task of assessing the strength and safety of their existing bridges. Over the last 50 years legal load limits for lorries have continually been increasing. In the U.K. the current maximum vehicle load of 38 tonne is to be increased to 40 tonne from 1st January 1999. The transport and trucking lobby is pressuring government to further, increase this load limit and it is almost inevitable that it will rise again in the future. Even without such increases, much of the U.K. bridge stock was designed and built for much lower loads than even the current 38 tonne limit. (It was only in 1983 that the maximum weight limit for lorries was raised from 32.5 to 38 tonnes).

In addition, many of the nation's bridges have deteriorated significantly and it was recognised that the management of the bridge stock would require knowledge of the overall condition of the population of bridges. In a study by a firm of consultants (Wallbank [10]), a random sample of 200 concrete bridges was examined to evaluate their performance and maintenance requirements. Deterioration was identified in 72% of these bridges which raised concerns about the number of deteriorated structures in

¹ ESReDA Working Group Report on "Industrial Application of Structural Reliability Theory", DNV, Høvik, Norway, 1998, pp.131-154.

the population as a whole and the consequences for bridge safety. As a result of these problems the U.K. Department of Transport launched a 15 year bridge rehabilitation programme in 1987 aimed at strengthening and repairing all the nation's bridges by January 1999. With around 160,000 bridges this is indeed a major task.

The total estimated cost of this motorway and trunk road bridge programme in England alone is £2.2 billion; National Audit Office [11]. In 1989, the Local Authorities in the United Kingdom started their own complementary bridge assessment and strengthening programme on all the bridges on secondary and minor roads. They estimate the cost of assessing and strengthening their bridges will also be in excess of £2 billion (Leadbeater [12]) bringing the total cost for upgrading the nation's bridges to over £4 billion.

By now many thousands of bridges have been assessed under this programme. Although the majority of structures have been found to be satisfactory, large numbers of bridges have "failed" their assessments. Up to the end of April 1996, 94% of the motorway and trunk road bridges in England had been assessed with 20% failing to meet the required standards. Local authorities, who maintain the majority of Britain's bridges, report even higher percentages of bridges "failing" their assessments.

Over £700 million has been spent since 1988 on assessing, upgrading and strengthening the motorway bridges of England alone. With such a massive problem facing the bridge owning authorities it is vital that engineers evaluate current methods of assessment and seek to refine and extend these so that the most realistic and relevant methods of analysis are used. Until now there has been only limited application of reliability analysis to bridge engineering and in particular to concrete bridge engineering, in the U.K. Some code calibration work was undertaken when limit states codes were first introduced although this was aimed at optimising partial safety factors in codes for the design of new bridges rather than the assessment of existing bridges.

The Highways Agency in the U.K. identified the potential for applying reliability based methods for assessing existing bridges and instigated a number of research projects to develop such methods.

One such study, which was aimed at developing bridge specific live-load models for short span bridges, has already resulted in a new code for assessment loading. In many situations' this results in a significant decrease in loading for many types of bridges without compromising the level of safety associated with these structures. Another important area of interest is the development of reliability based codes of practice for the structural analysis of both steel and concrete bridges. It is this latter bridge type which is considered in this paper.

3. DEFINITION OF THE PROBLEM

The goal was to develop a methodology with which a typical short span concrete bridge could be realistically assessed, taking into account the age of the structure and different levels of deterioration. For concrete bridges the primary mechanism of deterioration is corrosion of the steel reinforcement and hence appropriate models were needed to describe this process.

Several key questions need to be addressed. Firstly, what failure criterion should be adopted? Conventional bridge assessments are based, almost without exception, on deterministic linear elastic analysis. Hence the failure criterion is based on a single local failure of an element within the structure rather than global collapse. This will usually result in a very conservative estimate of the ultimate load capacity. For this

reason, a recently developed plastic collapse analysis method based on yield-line techniques was adopted for evaluating the load capacity of concrete bridges. This approach has been shown to model concrete slab bridges extremely well and overcomes the major difficulty faced in all structural reliability problems of finding a realistic method of analysis that can still be incorporated into a reliability format.

Since the goal was to be able to include provision for different repair strategies, serviceability criteria were also examined in the study.

The second key question is how one can relate the probabilistic calculation of risk of failure of a bridge to an actual level of risk acceptable to the public. This is perhaps the most difficult question in any reliability study. Studies instigated by the Highways Agency examined this question in detail although the matter is still under consideration. Traditionally reliability methods have been used in three main areas. These are (i) for ranking structures in relative order of risk of failure (ii) for investigating the sensitivity of a structure to variability in parameters such as material strength or applied loading and (iii) for calibration of code partial factors. To extend beyond this will require very careful and extensive calibration.

Here the aim is eventually to develop a risk based assessment procedure for concrete bridges in which satisfactory structures will be defined in terms of a certain (low) probability of failure. By considering the risk of failure at different load levels a simplified assessment code suitable for general use by the profession might then be derived. Clearly such a procedure will need extensive calibration before being adopted but it does hold out the prospect for a rationally based approach to bridge assessment. In particular this methodology should enable bridge managers to allocate resources more rationally on the basis of risk of failure,

4. PROBABILISTIC MODELLING

4.1 Limit states

Limit states are, according to Eurocode 2 [4], states beyond which the structure no longer the design performance requirements. Limit states are classified into:

Ultimate Limit States. Ultimate limit states are those associated with collapse, or with other forms of structural failure which may endanger the safety of people. States prior to structural collapse which, for simplicity, are considered in place of the collapse itself are also treated as ultimate limit states. Ultimate limit states which may require consideration include:

- loss of equilibrium of the structure or any part of it, considered as a rigid body.
- failure by excessive deformation, rupture, or loss of stability of the structure or any part of it, including supports and foundations.

Serviceability Limit States. Serviceability limit states correspond to states beyond which specified service requirements are not longer met. Serviceability limit states which may require consideration include:

- deformations or deflections which affect the appearance or effective use of the structure (including the malfunction of machines or service) or cause damage to finishes or structural elements.
- vibration which causes discomfort to people, damage to the building or its contents, or which limits its functional effectiveness.
- cracking of concrete which is likely to affect appearance, durability or water tightness adversely.

- Daming of concrete in the presence of excessive compression which is likely to lead to loss of durability.

In Eurocode2 [4], chapter 2.5.3.5.3. “Acceptable methods of analysis” for plates is stated:

The following methods of analysis may be used:

- linear analysis with or without redistribution;*
- plastic analysis based either on the kinematic method (upper bound) or on the static method (lower bound);*
- numerical methods taking account of the non-linear material properties.*

The application of linear methods of analysis is suitable for the serviceability states as well as for the ultimate limit states. Plastic methods, with their high degree of simplification, should only be used in the ultimate limit states.

Current methods of plastic analysis are: the yield line theory (kinematic method) and the strip method (lower bound or static method).

Four limit states are selected for the reliability analysis:

- two ultimate limit state (ULS): collapse limit state (using yield line analysis) shear failure limit state,
- a serviceability limit state (SLS): crack width limit state deflection limit state.

Collapse (Yield Line) Limit State

The following safety margin is used

$$Z = V E_D - W_D \quad (1)$$

where V is a model uncertainty variable, E_D is the energy dissipated in yield lines, and W_D is the work done by the applied loads.

The plastic collapse analysis and estimation of the load are performed using the COBRAS program; see Middleton [5]. The reliability analysis (element and system) is done using programs RELIAB01 [6] and RELIAB02 [7]. The RELIAB and COBRAS programs have been interfaced and include an optimisation algorithm to determine the optimal yield line pattern for each iteration of the reliability analysis, see also Thoft-Christensen [8]. The estimation of the deterioration of the steel reinforcement is based on the program CORROSION, see [8].

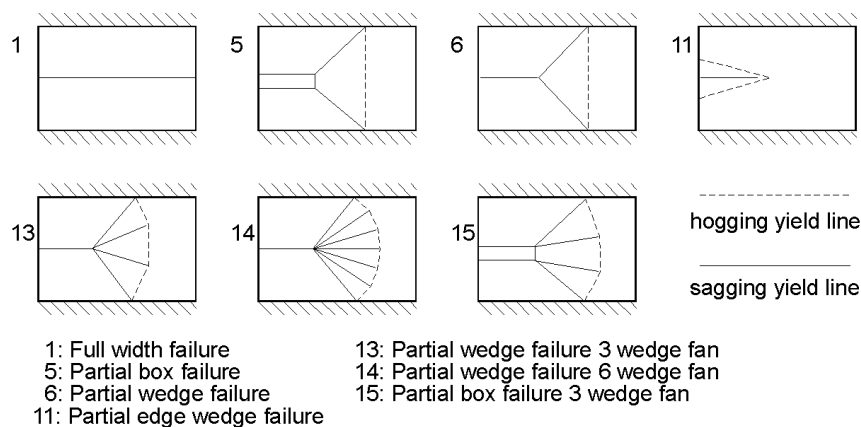

Figure 1. Failure modes for simply supported slab bridges.

The basic variables used in the yield line ULS are: thickness of slab, cube strength of concrete, density of concrete, depth of reinforcement, yield strength of reinforcement, and two load parameters.

COBRAS supports 16 different types of failure mode, seven are applicable to bridge slab analysis, see figure 1.

Shear failure limit state

Shear failure is modeled using a model applicable to reinforced concrete beams (see Middleton [5]) which may be written as

$$M_2 : g_2(\cdot) = Z_2 V_{j,ult} - V_j \quad (2)$$

where V_j is the shear force from external loads, $V_{j,ult}$ is the ultimate shear strength, v_c is the design shear stress, and ξ_s is the depth factor defined as

$$V_{ult} = \xi_s v_c b d, v_c = 0.24 \left(\frac{100 A_s}{b d} \right)^{1/3} f_c^{1/3}, \xi_s = \left(\frac{500}{d} \right)^{1/4} \quad (3)$$

where b is the width of the beam and d is the depth of the beam.

The stochastic variables used in the shear limit state are: thickness of slab, cover on reinforcement, concrete cube strength, yield stress of reinforcement, initial area of the reinforcement, density of concrete, static load factor, dynamic load factor, model uncertainty variable, and variables related to the chloride induced corrosion.

Crack width limit state

Cracking shall be limited to a level that will not impair the proper functioning of the structure or cause its appearance to be unacceptable. In the absence of specific requirements (e.g. water tightness), it may be assumed that limitation of the maximum design crack width to about 0.3 will generally be satisfactory for reinforced concrete members with respect to appearance and durability.

The design crack width may be obtained from (see González [13])

$$w_k = \beta s_{rm} \varepsilon_{sm} \quad (4)$$

where w_k is the design crack width, s_{rm} is the average final spacing, ε_{sm} is the mean strain allowing, under the relevant combination of loads, for the effects of tension stiffening, shrinkage, etc., and β is a coefficient relating the average crack width to the design value. For load induced cracking $\beta = 1.7$. The value of ε_{sm} may be calculated from

$$\varepsilon_{sm} = \frac{\sigma_s}{E_s} \left(1 - \beta_1 \beta_2 \left(\frac{\sigma_{sr}}{\sigma_s} \right)^2 \right) \quad (5)$$

where σ_s is the stress in the reinforcement calculated on the basis of a cracked section. σ_{sr} is the stress in the reinforcement calculated on the basis of a cracked section under the loading conditions causing first cracking.

β_1 is a coefficient which takes account of the bond properties of the bars. It is = 1.0 for high bond bars, and = 0.5 for plain bars. β_2 is a coefficient which takes account of the duration of the loading or of repeated loading. It is = 1.0 for single, short term loading, and = 1.5 for a sustained load or for many cycles of repeated loading.

The average final crack spacing (in mm) for members subjected dominantly to flexure or tension can be calculated from the equation

$$s_{rm} = 50 + 0.25k_1k_2\phi / \rho_r \quad (6)$$

where ϕ is the bar size in use (or the average bar size). ρ_r is the effective reinforcement ratio, $A_s / A_{c,eff}$, where A_s is the area of reinforcement contained within the effective tension area, $A_{c,eff}$. k_1 is a coefficient which takes account of the bond properties of the bar. It is = 0.8 for high bond bars and = 1.6 for plain bond bars. k_2 is a coefficient which takes account of the strain distribution. It is = 0.5 for bending and = 1.0 for pure tension.

The crack width limit state can then be formulated by

$$g(\cdot) = w_{max} - z_c w_k \quad (7)$$

where z_c is a model uncertainty stochastic variable.

The stochastic variables used in the crack SLS are: concrete cover, distance between reinforcement bars, diameter of reinforcement bars, thickness of slab, elastic modulus of reinforcement bars, tensile strength of concrete, external bending moment, and one model uncertainty variable.

Deflection limit state

The following deflection limit state is used

$$g(\cdot) = d_{max} - z_d d_k \quad (8)$$

where d_{max} is the maximum allowable deflection, d_k is the deflection estimated by linear elastic analysis, and z_d is a model uncertainty variable.

4.2 Deterioration

Mathematical modeling

Several models can be used to model the deterioration of reinforcement steel in concrete slabs. However, there is a general agreement that the model presented below is acceptable in most cases.

Corrosion initiation period refers to the time during which the passivation of steel is destroyed and the reinforcement starts to corrode actively. Practical experience of bridges in wetter countries like UK shows that chloride ingress is far bigger a problem than carbonation.

The rate of chloride penetration into concrete, as a function of depth from the concrete surface and time, can be represented by Fick's law of diffusion as follows:

$$\frac{\partial c}{\partial t} = D_c \frac{\partial^2 c}{\partial x^2} \quad (9)$$

where c is the chloride ion concentration, as % of the weight of cement, at distance x cm from the concrete surface after t seconds of exposure to the chloride source. D_c is the chloride diffusion coefficient expressed in cm^2/sec . The solution of the differential equation (9) is

$$(par,1; par,2) = \left(\frac{\partial \beta}{\partial u} \frac{u}{\beta}, \frac{\partial \beta}{\partial \sigma} \frac{\sigma}{\beta} \right) \quad (10)$$

where C_0 is the equilibrium chloride concentration on the concrete surface, as % of the weight of cement, x is the distance from the concrete surface in cm, t is the time in sec, erf is the error function, D_c is the diffusion coefficient in cm^2/sec , and $C(x,t)$ is the chloride concentration at any position x at time t . In a real structure, if $C(x,t)$ is assumed to be the chloride corrosion threshold and x is the thickness of concrete cover,

then the corrosion initiation period, T_I , can be calculated based on a knowledge of the parameters C_0 and D_C . For bridge decks under de-icing conditions $C_0=1.6$, as % of cement weight, is often used.

The time T_I to initiation of reinforcement corrosion is

$$T_I = \frac{(d_1 - D_1 / 2)^2}{4D_C} \left(\text{erf}^{-1} \left(\frac{C_{cr} - C_0}{C_i - C_0} \right) \right)^2 \quad (11)$$

where C_i is the initial chloride concentration, C_{cr} is the critical chloride concentration at which corrosion starts, and $d_1 - D_1 / 2$ is the concrete cover. For plain concrete of moderate strength ($f_{cu} \approx 30 \text{ N/mm}^2$) reported values of D_C are in the range between $1 \cdot 10^{-8}$ and $5 \cdot 10^{-8} \text{ cm}^2/\text{sec}$.

When corrosion has started then the diameter $D_I(t)$ of the reinforcement bars at time t is modeled by

$$D_I(t) = D_1 - C_{corr} i_{corr} t \quad (12)$$

where D_1 is the initial diameter, C_{corr} is a corrosion coefficient, and i_{corr} is the rate of corrosion. The area of a reinforcement bar is then modeled using the following formulation

$$A(t) = \begin{cases} nD_i^2 \frac{\pi}{4} & \text{for } t \leq T_I \\ n(D(t))^2 \frac{\pi}{4} & \text{for } T_I \leq t \leq T_I + D_i / (0.0203 \cdot i_{corr}) \\ 0 & \text{for } t > T_I + D_i / (0.0203 \cdot i_{corr}) \end{cases} \quad (13)$$

$$T_I = \frac{x_d^2}{4D_C \left(\text{erf}^{-1} \left(\frac{C_{cr}(x_d, t) - C_o}{C_i - C_0} \right) \right)^2}, \quad D(t) = D_i - 0.0203 \cdot (t - T_I) \cdot i_{corr}$$

$A(t)$ is the area of reinforcement bars [mm^2] at the time t years, n is the number of reinforcement bars, D_i is the diameter of a single bar [mm^2] and T_I is the corrosion initiation time in years. The value "0.0203" in the estimation of $D(t)$ will vary depending on the circumstances.

The initiation time of corrosion is determined based on values of $C_0, C_i, D_C, x_d, C_{cr}$. After the deterioration is started the corrosion rate is modeled by the corrosion current i_{corr} only.

The model for $A(t)$ (and the value of i_{corr} used) relates to an average deterioration of the reinforcement in the concrete. An important aspect of corrosion in addition to the average corrosion is the maximum penetration (pitting of reinforcement). Pitting of reinforcement may have more influence on the reliability than the average deterioration due to localized much higher weakening of the reinforcement. The ratio R between the maximum penetration PC_{\max} and the average penetration PC_{av} has been estimated by a number of authors to be between 4-10, see e.g. González et al. [13]. Pitting corrosion is not included in this investigation.

The stochastic variables used in the deterioration modeling are: initial chloride concentration on surface, initial chloride concentration in concrete, diffusion coefficient for the concrete, cover to reinforcement, critical chloride concentration, and rate of corrosion

4.3 Implementation

Based on a survey the following modeling for chloride penetration is proposed (the initial chloride is assumed to be zero):

<u>Model 0:</u>	Diffusion coefficient	$D_C : N(30.0, 5.0)$ [mm^2/year]
	Chloride concentration, surface	$C_0 : N(0.65, 0.075)$ [%]
	Corrosion density	$i_{corr} : \text{Uniform}[1.0, 3.0]$ [$\mu\text{A}/\text{cm}^2$]
	(Cover on reinforcement	$x_d : N(40.0, 4.0)$ [mm])

Figure 2 shows sample realizations of the chloride concentrations (at the depth of the reinforcement bar) for Model 0. Figure 3 shows sample realizations of the deterioration history of the reinforcement area for the same model.

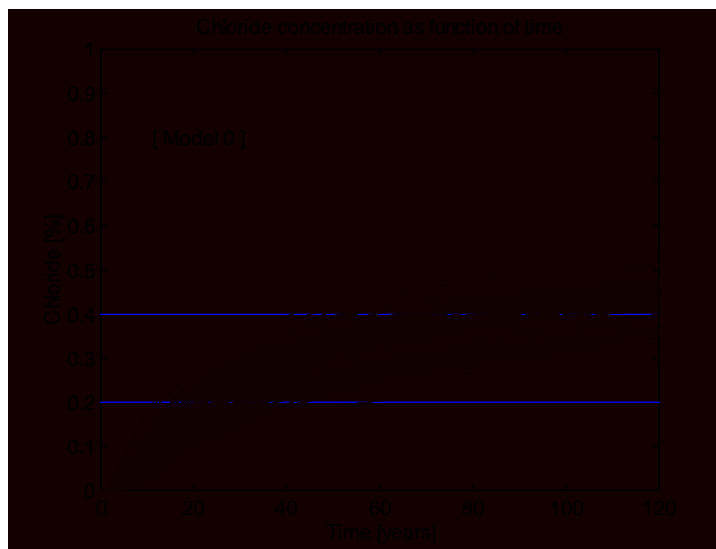

Figure 2. Samples showing the chloride concentration as a function of time for Model 0.

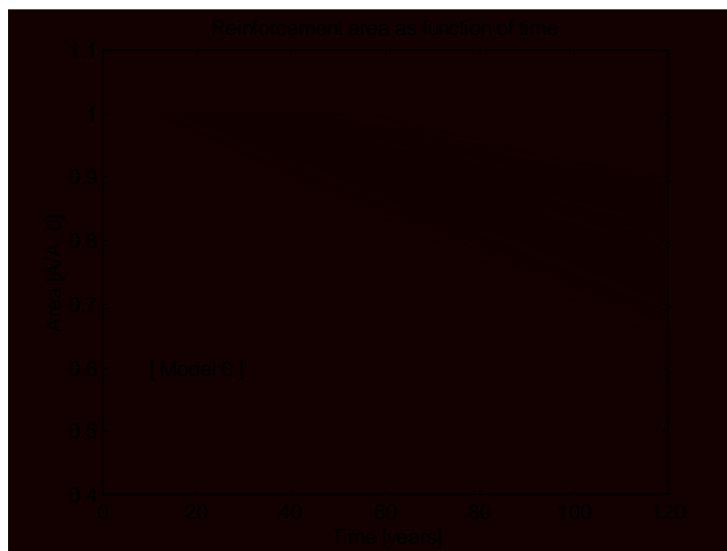

Figure 3. Normalized reinforcement area A/A_0 as a function of time for Model 0.

Based on the deterioration model 0 three levels of deterioration are proposed: low deterioration, medium deterioration and high deterioration. The deterioration parameters for these three levels are:

<u>Low:</u>	Diffusion coefficient	$D_C : N(25.0, 2.5) \text{ [mm}^2\text{/year]}$
	Chloride concentration , surface	$C_0 : N(0.575, 0.038) \text{ [%]}$
	Corrosion density	$i_{corr} : \text{Uniform}[1.0, 2.0] \text{ [}\mu\text{ A/cm}^2\text{]}$
<u>Medium:</u>	Diffusion coefficient	$D_C : N(30.0, 2.5) \text{ [mm}^2\text{/year]}$
	Chloride concentration , surface	$C_0 : N(0.650, 0.038) \text{ [%]}$
	Corrosion density	$i_{corr} : \text{Uniform}[1.5, 2.5] \text{ [}\mu\text{ A/cm}^2\text{]}$
<u>High:</u>	Diffusion coefficient	$D_C : N(35.0, 2.5) \text{ [mm}^2\text{/year]}$
	Chloride concentration , surface	$C_0 : N(0.725, 0.038) \text{ [%]}$
	Corrosion density	$i_{corr} : \text{Uniform}[2.0, 3.0] \text{ [}\mu\text{/cm}^2\text{]}$

Figure 4 shows sample realizations for the chloride concentration (at the depth of the reinforcement bar) for deterioration models: low, medium, high. The profiles obtained using mean values are shown for all three models. Figure 5 shows the sample realizations of the history of the reinforcement area for deterioration models: low, medium, high. The profiles obtained using mean values are shown for all three models.

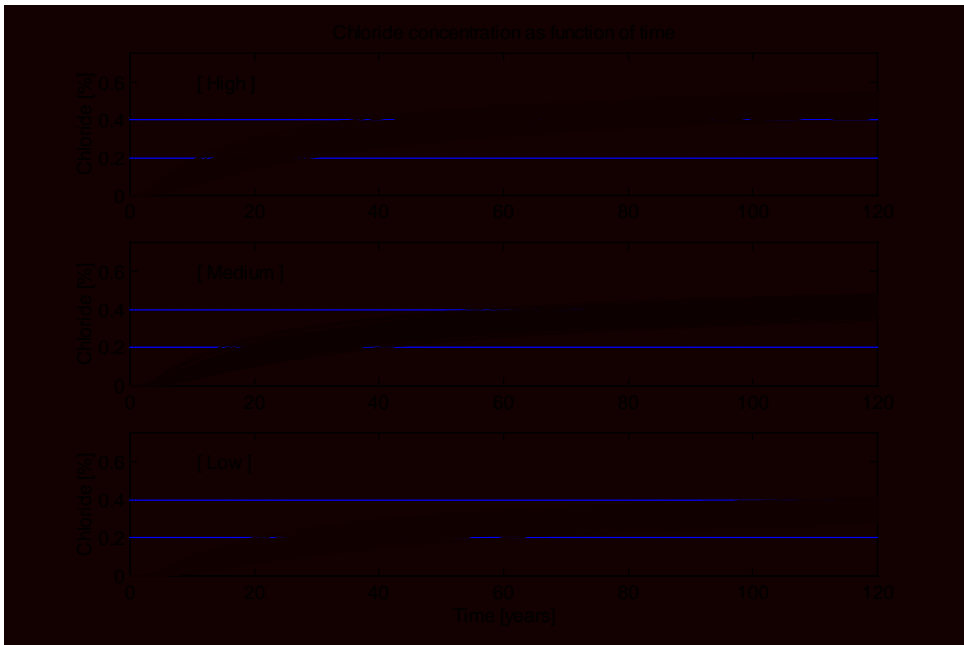

Figure 4. Samples showing the chloride concentration as a function of time for low, medium and high deterioration.

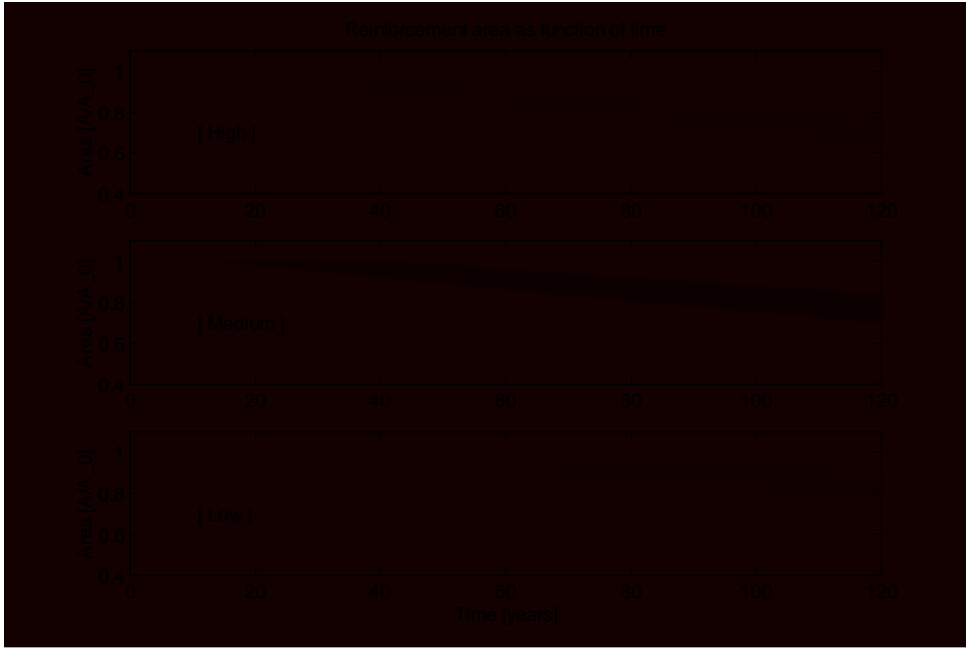

Figure 5. Normalized reinforcement area A / A_0 as a function of time for low, medium, and high deterioration.

5. RELIABILITY ASSESSMENT

5.1 Theory

The reliability of the bridge is measured using the reliability index β for a single failure element or for the structural system (the bridge) (Thoft-Christensen & Baker [16], Thoft-Christensen & Murotsu [17]). The reliability is assumed to decrease with time due to the deterioration. The failure modes can e.g. be stability failure of columns, yielding or shear failure in a number of critical cross-sections of the bridge. If a system modelling is used then it is assumed that the structure fails if anyone of these failure modes fails, i.e. a series system modelling is used.

It is assumed that uncertain quantities like loading, strength and inspection results can be modelled by N stochastic variables $\bar{X} = (X_1, \dots, X_N)$. At present the stochastic variables shown in table 1 are used. Further, the structure is modelled by m potential failure modes F_i , $i = 1, 2, \dots, m$. Failure mode i is described by a safety margin.

$$M_{F_i} = M_{F_i}(\bar{X}, t) \quad (14)$$

The element reliability index $\beta_i(t)$ at the time t for failure mode F_i is connected to the probability of failure $P_{F_i}(t)$ by (see Thoft-Christensen & Baker [16])

$$\beta_i(t) = \Phi^{-1}(P_{F_i}(t)) \quad (15)$$

where Φ is the standard normal distribution function. The probability of failure $P_{F_i}(t)$ in the time interval $[0, t]$ is determined from

$$P_{F_i} = P(M_{F_i} \leq 0) \quad (16)$$

In a time-invariant reliability analysis the estimate of the probability of failure can approximately be obtained by considering the extreme load in the lifetime T_L and

the strength at time i . The calculation time of a time-variant reliability index calculation is much higher than the calculation time of a time-invariant index calculation. Therefore, a time-variant reliability analysis should only be performed if it is absolutely necessary.

5.2 Example 1

The following example is used to illustrate the proposed methodology. The example is based on an existing UK bridge, but some limitations and simplifications are made. The bridge was built in 1975.

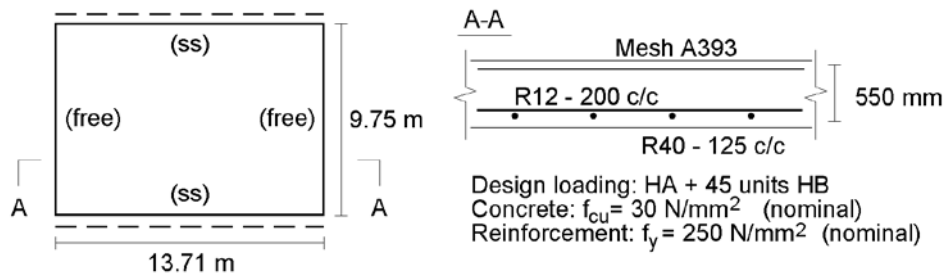

Figure 6. Bridge data.

The bridge was designed for 45 units HB load. The bridge has a span of 9.755 m, the width is 2×13.71 m, and the slab thickness is 550 mm (see figure 6).

Based on the corrosion data shown in table 1 the expected area of the reinforcement as a function of time can be calculated, see figure 7.

Stochastic variables: Yield line limit state				
No	Type	Par. 1	Par. 2	Description
1	Normal	550.0	10.0	Thickness of slab [mm]
2	LogNormal	30.0	6.0	Cube strength of concrete [MPa]
3	Normal	23.6	0.4	Density of concrete [kN/m^3]
4	LogNormal	289.0	25.0	Yield strength: longitudinal reinforcement [MPa]
5	Normal	60.0	8.0	Cover on longitudinal reinforcement [mm]
6	LogNormal	289.0	25.0	Yield strength: transverse reinforcement [MPa]
7	Normal	86.0	8.0	Cover on transverse reinforcement [mm]
8	Fixed	10053.0	-	Longitudinal reinforcement area (initial) [mm^2]
9	Fixed	565.0	-	Transverse reinforcement area (initial) [mm^2]
10	Gumbel	0.352	0.026	Static load factor [-]
11	Normal	1.27	0.20	Dynamic load factor [-]
12	Normal	1.08	0.072	Chloride concentration on surface [%]
13	Fixed	0.0	-	Initial chloride concentration [%]
14	Normal	35.0	2.5	Diffusion Coefficient [cm^2/sec]
15	Normal	0.4	0.05	Critical Chloride concentration [%]
16	Uniform	2.5	0.29	Corrosion parameter [-]
17	Normal	1.0	0.05	Model uncertainty variable [-]

Table 1. Stochastic modeling used for the ULS.

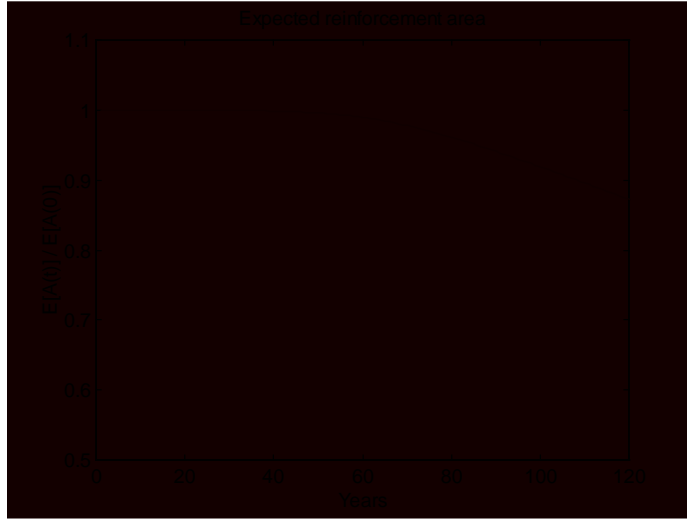

Figure 7. Relative reinforcement area $A(t)/A(0)$ as a function of time t .

Reliability profiles for the limit states discussed in section 4 are calculated on the basis of the stochastic modeling shown in tables 1 and 2.

Stochastic variables: Crack width limit state				
No	Type	Par. 1	Par. 2	Description
1	Normal	60.0	9.0	Concrete cover [mm]
2	Normal	125.0	12.5	Distance between reinforcement bars [mm]
3	Normal	40.0	1.2	Diameter of reinforcement bar [mm]
4	Normal	550.0	27.0	Thickness of slab [mm]
5	Normal	200.0E3	6.0E3	Young's modulus [N/mm ²]
6	Normal	3.4	0.68	Tensile strength [N/mm ²]
7	Gumbel	1.0	0.10	Model uncertainty [-]
8	Gumbel	0.352	0.026	Static load factor [-]
9	Normal	1.27	0.20	Dynamic load factor [-]
10	Normal	1.08	0.072	Chloride concentration on surface [%]
11	Fixed	0.0	-	Initial chloride concentration [%]
12	Normal	35.0	2.5	Diffusion Coefficient [cm ² /sec]
13	Normal	0.4	0.05	Critical Chloride concentration [%]
14	Uniform	2.5	0.29	Corrosion parameters [-]

Table 2. Stochastic modeling used for the SLS.

The general traffic highway load model in the Eurocode 1, Part 3 (ENV 1991-3:1995) for lane and axle load is applied. The load effects produced by the Eurocode model (lane and axle load) are multiplied by a static load factor (extreme type 1) and a dynamic load factor (normal).

The normalized reliability profile for the yield line ULS (full width failure) and the corresponding probability of failure profile are shown in figure 8. The reliability index at time $t = 0$ years is $\beta_0 = 11.5$. Due to the size of the concrete cover (mean value 60 mm) the deterioration does not have any effect until year 70.



Figure 8. : Reliability profiles using a yield line limit state.

The results from the sensitivity analysis with regard to the mean values are shown for $t = 0$ years and $t = 120$ years in figure 9. The most important variables are, as expected, the thickness of the slab, the yield strength of the reinforcement, and the model uncertainty. Observe that the magnitude of sensitivity with regard to the cover changes from negative at time $t = 0$ years to positive at time $t = 120$ years due to the corrosion.

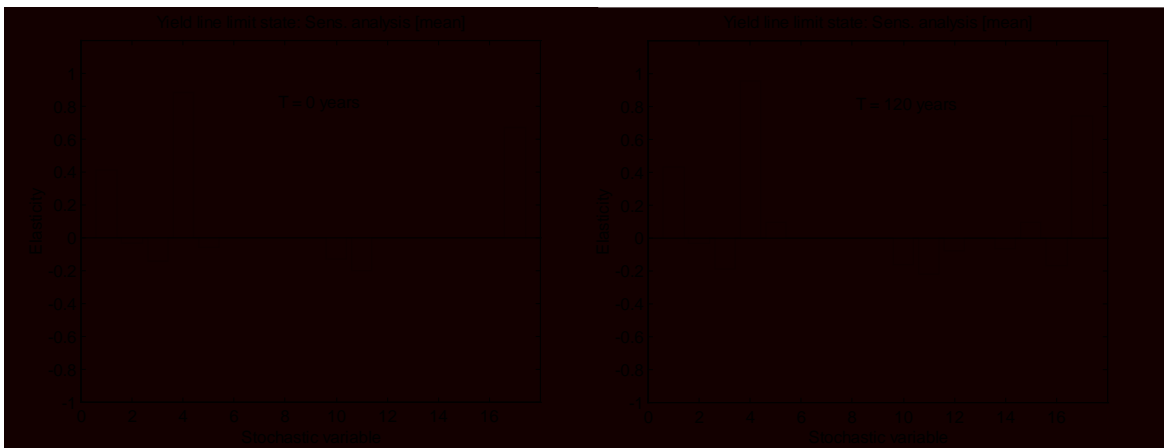

Figure 9 : Sensitivity analysis for yield line limit state at $t = 0$ years and at $t = 120$ years.

The normalized reliability profile for the crack SLS and the corresponding probability of failure profile are shown in figure 10. The reliability index at time $t = 0$ years is $\beta_0 = 7.1$. Due to the size of the concrete cover (mean value 60 mm) the deterioration does not have any effect until year 90.

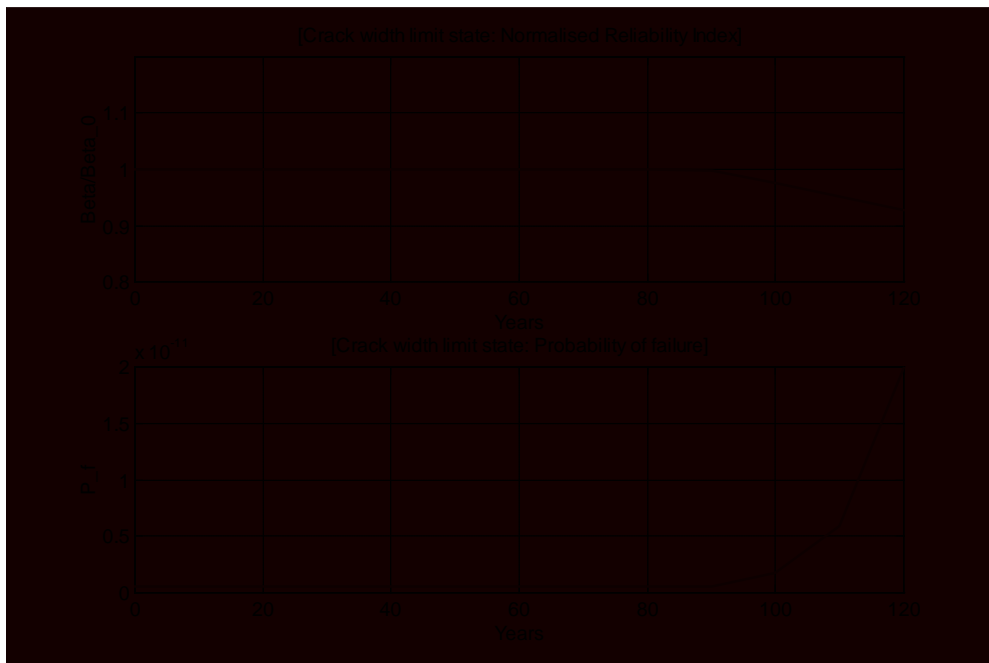

Figure 10: Reliability profiles using a crack width limit state

The results from the sensitivity analysis with regard to the mean values are shown for $t = 0$ years and $t = 120$ years in figure 11. The most important variables are as expected the concrete cover, the diameter of the reinforcement, the thickness of the slab, and Young's modulus. Observe that the magnitude of the sensitivity with regard to the cover is decreasing from time $t = 0$ years to time $t = 120$ years due to the corrosion.

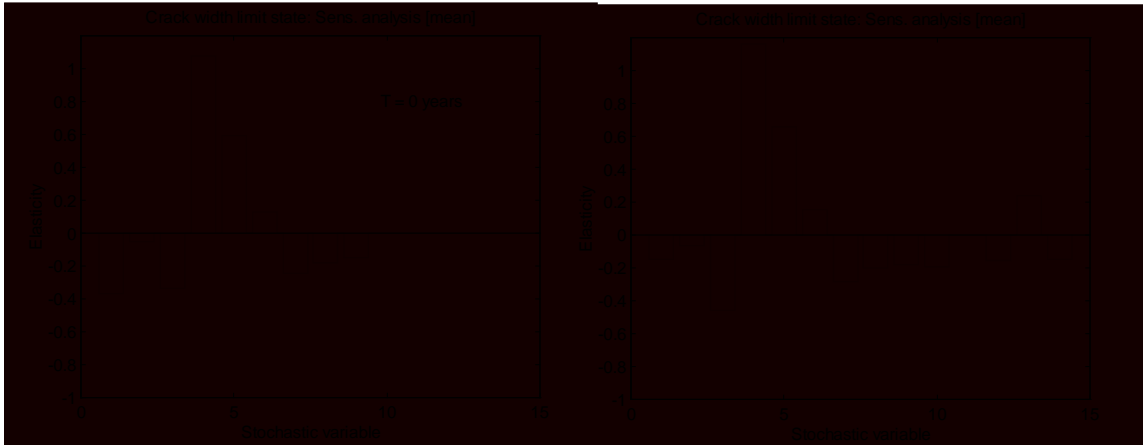

Figure 11: Sensitivity analysis for crack width limit state at $t = 0$ years and at $t = 120$ years.

5.3 Example 2

The bridge used in this example is a simple supported concrete slab with longitudinal and transverse reinforcement in bottom only, see figure 12. The span is 6.55 m and width is 9.50 m with a skew of 12.8 degrees. The deterministic values are: thickness of slab 480 mm, concrete strength 48.2 MPa, density of concrete is 23.6 kN/m^3 , the longitudinal reinforcement is $4275 \text{ mm}^2/\text{m}$ with a depth of 42 mm, and the transverse reinforcement is $950 \text{ mm}^2/\text{m}$ with a depth of 66 mm.

The loading applied is self weight, parapet and footpath loading. Only one load-combination/load case is examined.

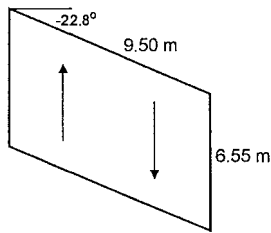

Figure 12. Main bridge data.

Stochastic variables: Crack width limit state				
No	Type	Par. 1	Par. 2	Description
1	Normal	480	100	Thickness of slab [mm]
2	LogNormal	482	5	Cube strength of concrete [MPa]
3	Normal	23.6	0.4	Density of concrete [kN/m ³]
4	LogNormal	250	25	Yield stress of: longitudinal reinforcement [MPa]
5	Normal	42	8	Cover on longitudinal reinforcement [mm]
6	LogNormal	250	25	Yield stress of: transverse reinforcement [MPa]
7	Normal	66	8	Cover on transverse reinforcement [mm]
8	Normal	23	1.2	Parapet
9	Normal	5	0.25	Footpath left
10	Normal	5	0.25	Footpath right
11	Normal	23	1.2	Footpath right
12	Normal	2.83	0.57	Asphalt
13	Gumbel	24.7	2.14	HA-lane
14	Gumbel	103.7	8.97	HA-kei

Table 3. Stochastic modelling.

14 stochastic variables are used in the reliability analysis. The stochastic variables, distributions and distribution parameters are listed in table 3. All stochastic variables are assumed uncorrelated. Stochastic variables 8-14 are load variables.

The failure mode used is for yield line (full width failure) which is a yield line running along the centre of the bridge parallel to the simple supports.

Below is shown results for FORM, SORM and simulation runs. The significant stochastic variables are 1 (thickness of slab), 4 (yield stress of steel) and 13 (lane loading).

Stochastic variable	α	u-value	x-value
1	-0.1305	-0.8981	471.02
2	0.0130	0.0896	48.389
3	0.0267	0.1835	23.673
4	-0.7198	-4.9540	151.76
5	0.1312	0.9029	49.223
8	0.0080	0.0554	230.66
9	0.0056	0.0384	5.0096
10	0.0056	0.0384	5.0096
11	0.0080	0.0553	23.066
12	0.0730	0.5025	3.1164
13	0.6603	4.5446	45.102
14	0.0718	0.4943	106.59

Table 4. FORM analysis. $\beta = 6.88$. $P_f = 2.9435E-12$.

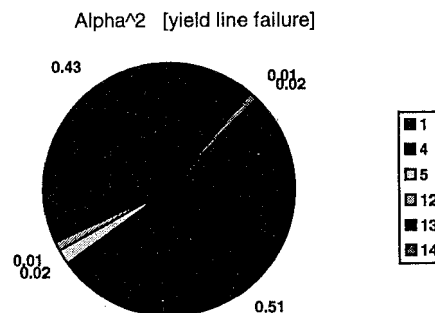

Figure 13: Results of yield line failure analysis. As seen from the "pie" chart the stochastic variables 4 (yield stress of steel) and 13 (HA lane load) are dominating for this failure mode.

Second order reliability index	6.82
Second order failure probability	4.6221E-12

Table 5. SORM analysis.

Using the FORM results the elasticities with respect to mean values and standard deviations are calculated. Results are listed below. Using the mean values the most significant is 4 (yield stress of steel) followed by 1 (thickness of slab), 3 (density of concrete), 13 (HA-lane) and 14 (HA-ke).

$$(par,1; par,2) = \left(\frac{\partial \beta}{\partial u} \frac{u}{\beta}, \frac{\partial \beta}{\partial \sigma} \frac{\sigma}{\beta} \right) \quad (17)$$

Stochastic variable	par,1	par,2
1	0.91016	-0.017030
2	-0.018304	0.00003
3	-0.22853	-0.00071
4	1.5745	-0.5259
5	-1.0008	-0.017213
6	0	0
7	0	0
8	-0.0224	-0.000006
9	-0.016231	-0.00003
10	-0.016230	-0.00003
11	-0.022397	-0.00006
12	-0.052669	-0.00533
13	-0.29927	-0.02472
14	-0.11246	-0.00313

Table 6. Elasticity sensitivity coefficients.

Note: Elasticities with respect to standard deviation is (for all real examples) always negative. The (very small) positive values for stochastic variables 6,7 are due to numerical inaccuracies. Variables 6,7 (transverse reinforcement) have no influence on the failure mode analysis (Full- width failure).

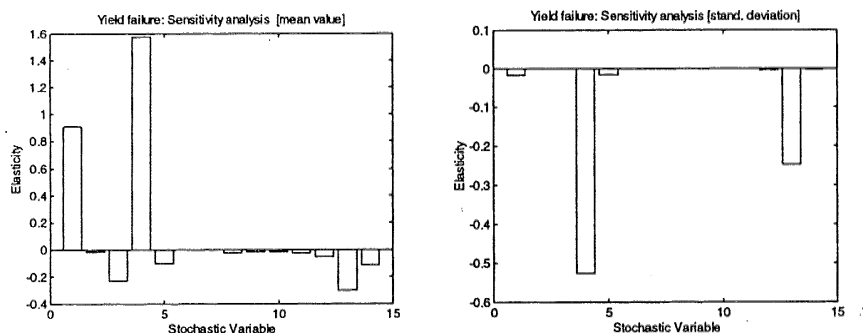

Figure 14: Sensitivity analysis for yield line failure. The right chart shows the elasticities w.r.t. the mean values of the stochastic variables, and the chart to the left shows the elasticities w.r.t. the standard deviation.

Using a library of potential failure modes for concrete slab bridges the reliability index is calculated for 14 different failure modes. The reliability index for all failure

modes and the corresponding correlation matrix is listed below.

Failure element no:	Failure mode no:	Reliability index	Failure modes (critical)
1	1	6.88	Full width failure
2	2	9.00	
3	3	9.53	
4	4	13.74	
5	5	8.71	
6	6	8.71	Partial wedge failure
7	7	9.70	
8	8	10.57	
9	10	10.18	
10	11	23.09	
11	12	21.31	
12	13	7.75	Partial wedge failure 3w fan
13	15	8.14	
14	16	8.90	

Table 7. Reliability indices for different failure modes.

	1	2	3	4	5	6	7	8	10	11	12	13	15	16
1	1.00													
2	.969	1.00												
3	.976	.999	1.00											
4	.965	.993	.994	1.00										
5	.978	.999	1.00	.993	1.00									
6	.980	.999	.999	.993	1.00	1.00								
7	.935	.993	.989	.986	.988	.987	1.00							
8	.948	.996	.994	.990	.993	.992	.999	1.00						
10	.944	.996	.993	.989	.992	.991	1.00	1.00	1.00					
11	.748	.641	.640	.645	.652	.663	.575	.588	.585	1.00				
12	.989	.954	.959	.964	.963	.966	.918	.931	.927	.784	1.00			
13	.987	.996	.998	.991	.999	.999	.979	.986	.984	.681	.974	1.00		
15	.982	.998	.999	.994	1.00	1.00	.985	.991	.989	.664	.969	.999	1.00	
16	.989	.974	.979	.983	.980	.981	.946	.957	.954	.726	.993	.987	.985	1.00

Table 8. Correlation matrix.

As expected the correlations between failure modes are in the range [0.90; 0.99] for all failure modes (except failure mode 11). As an example the systems reliability is evaluated on basis of the failure modes of the three lowest reliability indices. The systems reliability is modelled as a series system with three failure modes as elements. The minimum reliability index is 6.88 and the series reliability index is 6.71.

Failure mode	β	$\bar{\alpha}$ vector
1	6.882	-0.131 0.013 0.027 -0.720 0.131 0.000 0.000 0.008 0.006 0.006 0.008 0.073 0.660 0.072
6	8.172	-0.131 0.012 0.019 -0.594 0.108 -0.093 0.001 0.000 0.006 0.000 0.000 0.054 0.777 0.055
13	7.748	-0.130 0.012 0.020 -0.620 0.107 -0.066 0.003 0.008 0.006 0.000 0.000 0.057 0.759 0.059
Series system	6.709	

Table 9. Series system reliability analysis.

The crack width limit state is modelled as in section 4. The limit state equation applied is formulated as

$$g = w_{\max} - z_l w_k \quad (17)$$

where z_l is a model uncertainty variable, w_{\max} is the maximum allowable crack width and w_k is the calculated average crack width.

$$w_k = \beta s_m \varepsilon_{sm}, \quad s_m = \left(50 + 0.25k_1k_2 \frac{\phi}{\rho_r} \right), \quad \varepsilon_m = \left(1 - \beta_1\beta_2 \left(\frac{\sigma_{sr}}{\sigma_s} \right)^2 \right) \frac{\sigma_s}{E_s} \quad (18)$$

$$w_k = \beta \left(50 + 0.25k_1k_2 \frac{\phi}{\rho_r} \right) \left(1 - \beta_1\beta_2 \left(\frac{\sigma_{sr}}{\sigma_s} \right)^2 \right) \frac{\sigma_s}{E_s} \quad (19)$$

In a previous CEB proposal the value 50 in (18) was replaced by a term including the value of the concrete cover and the spacing of the reinforcement bars

$$2 \left(c + \frac{s}{10} \right) \Rightarrow 2c + 0.2s = 50 \quad (20)$$

where c is the concrete cover and s the spacing between reinforcement bars. Assuming pure bending (Full width failure), and using appropriate values ($k_1=0.8$ and $k_2=0.5$, $\beta_1=1.7$, $\beta_2=1.0$) and the formulation given in (17) gives the limit state

$$g = w_{\max} - z_1 \left(2c + 0.2s + 0.1b(c + 8\phi) \frac{\phi}{A_s} \right) \left(1 - \left(\frac{M_r}{M} \right)^2 \right) \left(\frac{M}{k_z d A_s E_s} \right) \quad (21)$$

where $g < 0$ indicates failure, w_{\max} is the maximum crack width [mm], z_1 is a model uncertainty variable, c is the concrete cover [mm], s is the distance between reinforcement bars [mm], ϕ is the diameter of the bar [mm], b is the width (here 1000 mm), A_s is the steel area, M_r is the cracking moment, M is the external moment, k_z is a factor on the lever arm, and E_s is elastic modulus (reinforcement).

To simplify the calculation (and due to some missing information regarding the bridge used) a number of simplifications and assumptions have been made. The reinforcement area/m is 4275 [mm²]. The reinforcement is assumed to be $d = 24$ [mm], $s = 100$ mm (area = 4520 [mm²]). The loading is used to calculate an approximate value of M which is then given a coefficient of variation equal to 0.10. In the final reliability assessment both the modelling of the loading and the calculation of moments will be replaced by more accurate methods. The concrete cover, distance between reinforcement bars, diameter of reinforcement, height of profile, elastic modulus for steel, the tensile strength of concrete, the external moment are all modelled as stochastic variables, see below.

No.	Type	Par. 1	Par. 2	Description
1	Normal	30	4.5	Concrete cover [mm]
2	Normal	100	10	Distance between rebars s [mm]
3	Normal	24	0.72	Diameter of rebars ϕ [mm]
4	Normal	480	24	Height of profile h [mm]
5	Normal	0.2E+06	0.6E+04	Elasticity module E_s [N/mm ²]
6	Normal	3.4	0.68	Tensile strength [Nmm ²]
7	LogNormal	0.188E+09	0.188E+08	External moment [Nmm]
8	Gumbel	1	0.1	Model uncertainty

Table 10. Stochastic modeling. $w_{\max} = 0.3$ mm.

This gives a FORM reliability index of 7.26 with a corresponding probability of failure equal to 1.87E-13. Decreasing the allowable crack width from 0.3 [mm] to 0.2 [mm] decreases the reliability index to $\beta = 5.75$ and a failure probability equal to 4.39E-09.

Stochastic variable	α	u -value	x -value
1	0.2850	2.0708	39.318
2	0.0467	0.3394	103.39
3	-0.2432	-1.7667	22.728
4	-0.3190	-2.3173	424.38
5	-0.1159	-0.8423	194950
6	-0.1872	-1.3597	2.4754
7	0.4437	3.2235	2.5802E+08
8	0.7143	5.1894	2.2076

Table 11. FORM analysis. $\beta = 7.26$. $P_f = 1.8706E-13$.

Stochastic variable	α	u -value	x -value
1	0.2850	2.0708	39.318
2	0.0467	0.3394	103.39
3	-0.2432	-1.7667	22.728
4	-0.3190	-2.3173	424.38
5	-0.1159	-0.8423	194950
6	-0.1872	-1.3597	2.4754
7	0.4437	3.2235	2.5802E+08
8	0.7143	5.1894	2.2076

Table 12. Elasticity sensitivity coefficients.

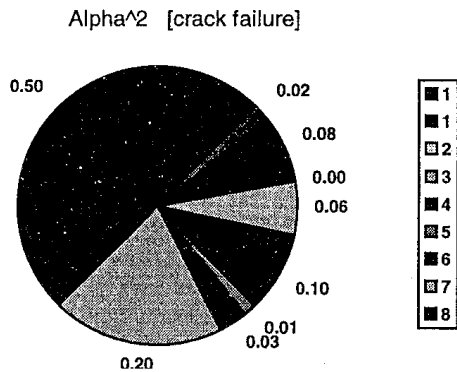

As seen from both the values of the alpha vector and the values of the elasticities all stochastic variables are significant in the calculation of the reliability index, with stochastic variables 3, 4, 7, and 8 as dominating.

Figure 15: Results of the crack failure analysis. The stochastic variable 8 (model uncertainty) is dominating in this analysis.

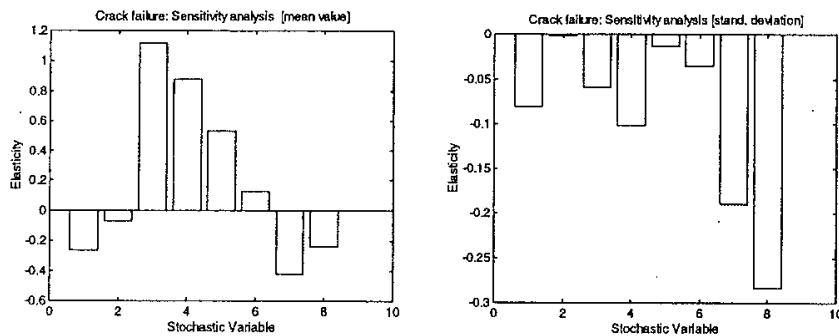

Figure 16: Sensitivity analysis for crack failure.

The right chart shows the elasticities w.r.t. the mean values of the stochastic variables, and the chart to the left shows the elasticities w.r.t. the standard deviation.

6. DISCUSSION

These particular examples examine the reliability of two existing concrete bridges subject to four separate failure criteria. Provision for time-varying deterioration of reinforcement has been incorporated. The same methodology could be applied to any concrete bridge deck.

In the Highways Agency project, fifteen different concrete bridges were analysed and reliability profiles derived for each. This work is now to be extended to cover a larger sample and wider range of concrete bridges and also to examine various levels of live load.

Several important issues arise from this work. It is still extremely difficult to accurately model the ultimate strength of concrete bridges due to the complex non-linear behaviour of this non-homogeneous material. For slabs, yield-line analysis is probably the best analysis option available although limited to flexural failures and it is also reliant upon sufficient ductility in the slab to allow plastic redistribution of loads. Clearly the choice of failure criterion is important and will affect the numerical value of the reliability index obtained. More research needs to be undertaken to understand better the sensitivity of the reliability index to the choice of failure function. It is also very difficult to get measurements of the progressive loss of steel area due to corrosion in bridge decks. In reality corrosion is often found in isolated locations with intense pitting of bars rather than as a uniform loss of steel over the entire deck. To incorporate such an effect would add a significant level of complexity into the modelling of corrosion. Results will also be sensitive to the number and statistical properties of the basic variables used in the analysis. Again more information is needed in this area.

The challenge now is to build up the necessary database to allow the parameters used in this bridge assessment methodology to be refined and improved. This methodology provides a means by which rational reliability methods can be used for comparing the risk of failure of concrete bridges, providing a useful tool for bridge managers to use in defining priorities for bridge repair, strengthening and replacement.

7. ACKNOWLEDGEMENT

The authors would like to thank the Highways Agency, London for permission to publish this paper. The work herein was carried out under a contract placed on CSRconsult by the HA. The authors are particularly grateful to Dr. P. Das of the Highways Agency for his contributions to the fundamental philosophy of this work. However, any views expressed in this paper are not necessarily those of the Highways Agency of the U.K. Department of Transport.

8. REFERENCES

- [1] Thoft-Christensen, P., F.M. Jensen, C. Middleton & A. Blackmore: "Assessment of the Reliability of Concrete Slab Bridges". Proceedings IFIP WG7.5 Conference, Boulder, USA, April 2-4, 1996, pp. 321-328.
- [2] Thoft-Christensen, P., F.M. Jensen, C. Middleton & A. Blackmore: "Revised Rules for Concrete Bridges ". In *Safety of Bridges* (editor P.C. Das), The Institution of Civil Engineers, Thomas Telford, 1997, pp. 175-188.

- [3] Thoft-Christensen, P: "Re-Assessment of Concrete Bridges". Proceedings ASCE Structures Congress, Chicago, USA, April 14-18, 1996.
- [4] Eurocode 2: Design of concrete structures - Part 1-1: General rules and rules for buildings, ENV 1992-1:1991.
- [5] Middleton, C. Example Collapse & Reliability Analyses of Concrete Bridges using a new Analyses Technique. Cambridge University, 1994.
- [6] RELIAB01, Version 2.0, manual and software. CSR-software, March 1994.
- [7] RELIAB02, Version 2.0, manual and software. CSR-software, April 1994.
- [8] Thoft-Christensen, P.: "Reliability of Plastic Slabs", ICOSSAR Conference, San Francisco, USA, August 1989.
- [9] CORROSION, Version 1.0, manual and software. CSR-software, September 1995.
- [10] Wallbank, E.J.: "The Performance in Concrete in Bridges – A Survey of 200 Highway Bridges". Report, HMSO, London, UK, 1989.
- [11] National Audi Thoft-Christensen, P. & M.J. Baker. Structural Reliability Theory. Springer Verlag. 1982.
- [12] National Audit Office. Highways Agency: "The Bridge Programme". Report HC 282, MNSO, London, UK, 1996.
- [13] Leadbeater, A.D.: "The Financial Settlement 1996/97". 4th Annual Surveyor Bridges Conference, Nottingham, February 1996.
- [14] González, J.A., C. Andrade, C. Alonso & S. Feliu: "Comparison of Rates of General Corrosion and Maximum Pitting Penetration on Concrete Embedded Steel Reinforcement", Cement and Concrete Research, Vol. 25, No. 2, pp. 257-264, 1995.
- [15] Department of Transport. Loads for Highway Bridges. Departmental Standard BD37/88, London, 1989.
- [16] Thoft-Christensen, P. & M.J. Baker. Structural Reliability Theory and Its Applications. Springer Verlag. 1982.
- [17] Thoft-Christensen, P. & Y. Murotsu. Application of Structural Systems Reliability Theory. Springer Verlag. 1986.

