



AALBORG UNIVERSITY
DENMARK

Aalborg Universitet

Papers, volume 5 - 1997-2000

Thoft-Christensen, Palle

Publication date:
2006

Document Version
Publisher's PDF, also known as Version of record

[Link to publication from Aalborg University](#)

Citation for published version (APA):
Thoft-Christensen, P. (2006). *Papers, volume 5 - 1997-2000*. Aalborg Universitetsforlag.

General rights

Copyright and moral rights for the publications made accessible in the public portal are retained by the authors and/or other copyright owners and it is a condition of accessing publications that users recognise and abide by the legal requirements associated with these rights.

- Users may download and print one copy of any publication from the public portal for the purpose of private study or research.
- You may not further distribute the material or use it for any profit-making activity or commercial gain
- You may freely distribute the URL identifying the publication in the public portal -

Take down policy

If you believe that this document breaches copyright please contact us at vbn@aub.aau.dk providing details, and we will remove access to the work immediately and investigate your claim.

CHAPTER 96

FIRE SAFETY ASSESSMENT AND OPTIMAL DESIGN OF PASSIVE FIRE PROTECTION FOR OFFSHORE STRUCTURES¹

N.K. Shetty *, C. Guedes Soares**, P. Thoft-Christensen*** & F.M. Jensen***,

* WS Atkins, Epsom, UK

** Technical University of Lisbon, Lisbon, Portugal

*** CSRconsult, Aalborg, Denmark

ABSTRACT

The article presents a unified probabilistic approach to fire safety assessment and optimal design of passive fire protection on offshore topside structures. The methodology was developed by integrating quantitative risk analysis (QRA) techniques with the modern methods of structural system reliability analysis (SRA) and reliability based design optimisation (RBDO). Reliability analysis methodologies are presented for both plated (e.g. fire and blast walls) and skeletal structures (deck framing), which take into account uncertainties in fire and blast loading, thermal and mechanical properties of the steel and insulation. Probability of component and system failure is evaluated using first- and second-order reliability methods (FORM/SORM). The optimisation of passive fire protection is performed such that the total expected cost of the protection system is minimised while satisfying reliability constraints.

1. INTRODUCTION

The occurrence of a number of recent major accidents, both on- and off-shore, has demonstrated the inadequacy of the traditional “prescriptive” approach in addressing the root causes of failure. The risk of a major accident depends on a number of platform-specific features such as the type of processing, volume of inventory, layout

¹ Reliability Engineering and System Safety, Vol.61, 199, pp. 139-149.

of the topside, number of personnel, etc., and it is very difficult to standardise and codify safety systems and procedures for all installations. In addition, human factors such as management attitude, safety culture, style of supervision, employee motivation, operating procedures, etc., play a large part in the maintenance of safe operations. As a result, all the major hydrocarbon producing countries of the North Sea have now adopted a “goal setting” and “proactive” approach for safety management of offshore installations (see, for example, Ref. [1]). This has led to a requirement for methods and tools to identify and quantify explicitly all hazards to an offshore installation.

Although formal methods of risk analysis have been used for this purpose for some time, difficulties exist, notably in the treatment of uncertainties involved in fire and blast load estimation and in the quantification of the probability of failure of structural components and systems for which historical data are generally not available. While a number of advanced tools are now available which can quantify a particular effect in isolation (“sub-models”), a rigorous yet practical methodology for combining all the various effects in a unified and consistent way has hitherto been lacking.

The article proposes a unified and consistent approach for the safety assessment of topside structures and optimisation of passive fire protection. This is achieved by integrating conventional risk-analysis techniques with the modern methods of structural reliability analysis and reliability-based design optimisation (RBDO). The paper presents methodologies for the evaluation of probabilities of failure of plated and skeletal structures under fire and blast conditions. A reliability-based optimisation methodology is also presented for the optimisation of passive fire protection on offshore topsides. These methods should be used within a wider framework of safety management encompassing hazard prevention, control, mitigation, emergency response and monitoring and control measures to be used during operations.

In the UK, with the introduction of the Safety Case Regulations, Ref. [1], the responsibility for the safety of an offshore installation was placed on the operator. The regulations require that the operator produces a “safety case” for each installation and it is formally accepted by the regulator. A “goal setting” approach is advocated in which the operator defines the safety criteria for the installation and demonstrates that all hazards have been identified and their risks evaluated and reduced to a level that is “As Low As Reasonably Practicable-ALARP”. A safety management system (SMS), which forms a part of the safety case, provides the organisational framework for the assessment and management of all hazards. Detailed requirements for the management of fire and explosion hazards are contained in the PFEER Regulations (prevention of fire and explosion and emergency response; see [2]).

Fire and explosion hazards need to be managed at all stages of oil and gas exploration and production in a proactive way to reduce risks. The hazard management process comprises the following stages; see [3]:

1. identification of the hazards (and coarse quantification);
2. analysis of the hazards (type, scale, intensity, duration, likelihood, consequence, etc.);
3. reduction of the hazards through inherent safe design;
4. identification and specification of particular prevention, control and mitigation measures needed for each hazard;
5. development of effective systems and procedures for emergency response;
6. verification of each strategy and provision of the above;
7. documentation, communication and implementation.

Quantitative risk analysis (QRA) is used to understand and assess fire and

explosion hazards, and forms the basis of hazard management in stages 1-5.

This paper is focused on the reliability assessment of structural systems and optimisation of their passive fire protection. Detailed guidance on the overall hazard management process and the design of appropriate prevention, control and mitigation systems can be obtained, for example, from Ref. [3].

2. INTEGRATED METHODOLOGY FOR PROBABILISTIC FIRE SAFETY

The overall objective of the OFSOS project which started in 1992 and finished in 1995 was the development of a unified, probabilistic methodology for fire safety, involving hazard identification, consequence analysis, escalation modelling, fire and blast load modelling, structural and overall risk assessment and optimisation of fire protection. This has involved the development of new methodologies in specific areas such as

- probabilistic modelling of fire and blast loading;
- probabilistic modelling of temperature rise within structural components;
- probabilistic modelling of non-linear structural response under thermal loading;
- development of methodologies for system reliability assessment of framed (e.g. MSF) and plated structures (e.g. fire/blast walls) under fire and blast loading;
- development of RBDO techniques for passive fire protection of topside structures.

The above theoretical developments were implemented into individual software modules and subsequently integrated into a software suite. This software was used to perform extensive case studies on four existing offshore structures (2 North Sea, I Congo and I Mediterranean), covering different types of layout and being subject to different fire scenarios. These case studies have helped to identify dominant hazard scenarios for these types of platforms and the key parameters of optimal fire safety of offshore structures. The main steps in the identification and assessment of fire and explosion hazards are:

1. hazard identification;
2. event-tree analysis;
3. probabilistic analysis;
4. fatality evaluation;
5. risk estimation.

In the conventional QRA approach for fire safety assessment, the event-tree method is used to identify and quantify the probabilities of accidental scenarios leading to, for example, an explosion, a pool fire or a jet fire etc. However, the consequence of such an accidental event on the integrity of process piping and vessels, structural systems, temporary refuges, escape ways etc. is assessed largely using deterministic methods.

The OFSOS methodology provides a unified probabilistic approach to fire structural assessment and optimal design of passive fire protection on offshore topsides. The methodology was developed by integrating

- QRA techniques
- Fire and explosion models
- Heat transfer models
- Non-linear structural analysis methods
- Structural system reliability analysis (SRA) techniques, and

- REDO methods.

This integration was achieved by using platform-specific 'extended' event-trees which model in detail the escalation paths leading to catastrophic events such as loss of escape ways, loss of temporary refuge, loss of evacuation systems or structural collapse of the topside. Further details of this approach can be found in Ref. [4].

The frequencies of most events in the event-tree are evaluated in the usual way based on historical data. The probabilities of those events for which historical data are not available are calculated using structural reliability methods by taking into account the uncertainties in the fire loading parameters (exit size, flow-rates, fuel properties, fire models), thermal properties (insulation thickness, thermal properties of structural steel and the insulation) and structural properties (yield strength, expansion coefficient, etc.). The methodology for reliability analysis of plated structures is described in Section 3, while the methodology for skeletal structures is given in Section 4.

The results of probabilistic analysis and fatality calculations are used to quantify the risk of various accidental scenarios defined in the event-tree from which dominant hazard scenarios can be identified. The prevention, control and mitigation systems are then designed to manage these hazards.

In addition to the conventional Cost-Benefit Analysis techniques used for the design of safety systems, modern methods of reliability-based optimisation are used for the design of fire protection on the topside. The optimisation procedure, described in Section 5, minimises the expected total cost, which includes initial cost and maintenance costs of the protection system and cost of failure of the platform while satisfying safety constraints.

3. RELIABILITY OF PLATED STRUCTURES

In using conventional QRA methods, one of the difficulties is in the evaluation of probabilities of failure of structural components and systems, as historical failure data are not available for these. Ultimately, however, it is the structural system which holds the balance between the platform survival or failure in a major accident, and a rational approach for the evaluation of structural failure probability is vital for the overall risk assessment.

In the modelling of escalation events and in determining the frequencies of impairment of TR and EER facilities, probabilities of failure of the following types of components and systems need to be evaluated.

- Module support frame (MSF)
- Drilling derrick, flare boom, bridge, etc.
- Process piping and process vessels
- Escape ways
- Deck plating, module cladding, etc.
- Fire/blast walls

Methodology and software tools were developed for time-dependent reliability analysis which can be used to predict failure probabilities of the above types of components and systems under pool fire, jet fire and explosion conditions.

A methodology for structural reliability analysis under fire and blast conditions requires the following sub-models.

- Fire load modelling
- Heat transfer modelling

- Temperature dependent collapse of components
- Progressive collapse of structural systems
- Uncertainty modelling
- Component reliability analysis
- SRA

The reliability methodology for plated structures under fire conditions is described later, and that for skeletal structures is given in Section 4.

3.1 Fire and blast load modelling

The models for pool and jet fire loading were developed by integrating a number of empirically based sub-models reported in the literature.

The model for pool fires is a surface emitter model in which the flame is represented by a tilted cylinder with an elliptical horizontal base which enables the downwind flame spill-over to be represented. The burning rate is provided on the basis of thermodynamic properties of the fuel, and for small fires the flame length is corrected using the Thomas [5] correlation. Enhancements were made to account for compartment and water deluge effects on fire. The model was validated against experimental data provided by Shell and British Gas.

For jet fires, a surface emitter model based on the work of Chamberlain [6] is used. It treats the flame as a uniformly radiating solid body with constant emissive power and shaped as the frustum of a cone. The flame geometry, orientation and radiated heat flux are described using empirical correlations. The case of two-phase flow or liquid jet fires are covered by calculating an equivalent gas jet velocity. The model accounts for flame lift-off, tilting and stretching in a cross wind.

The model predictions for both pool and jet fires were compared against results from Computational Fluid Dynamics code FLOW3D and it is concluded that the simpler models give reasonably good predictions when used within the limits of their validity.

A probabilistic model was formulated to describe the uncertainties of the fire models and to identify the variables that contribute to the overall uncertainties of the predictions; see [7].

For blast loading, the model is based on the work of Cubbage and Simmonds [8]. It predicts the pressure peak associated with the venting of the flame from the vessel. However an estimated turbulent velocity is used in place of laminar burning velocity to allow for flame acceleration resulting from the flame stretch and high turbulence levels expected in congested offshore modules. The predictions of the model were compared against experimental data taken from explosion tests in 1:5 scale offshore modules and in larger wedge-shaped enclosures.

3.2 Modelling of heat transfer

For evaluating the heat transfer in skeletal and plated structures, the numerical algorithm is based on the conventional formulation and solution of heat-balance equations. Based on the input of heat fluxes on the surface of members, temperatures, as a function of time, at various points of the structural model are calculated. Various types of structural components, such as plates, tubes, I-beams, channels, etc. can be considered with and without thermal insulation.

The structural members are discretised into a number of meshes in the axial direction and the cross-section is divided into a number of sub-elements. Each sub-

element is assumed to have a uniform heat flux over its surface. Similarly, the insulation is discretised into a number of meshes along its thickness. At present only the radiative heat transfer is modelled while the conduction and convective components are ignored.

3.3 Strength of plated components

Plate elements are one of the basic components of topsides of offshore platforms, while beam-columns are the components that make the framework supporting the platform topsides. Plate elements supported by the framework make the decks and ceilings. Plates are also used in the walls of the compartments, both when they are aimed at providing blast resistance or only as a barrier for the thermal load induced by fires.

The behaviour of rectangular plate elements under thermal loads of magnitudes that can be reached during fires in offshore platforms was studied by Guedes Soares et al. [9]. The increase of temperature associated with the fires will induce a tendency for the plates to expand. However, the restrictions provided by the boundaries, which may be at a lower temperature, induce bi-axial compression on the plates leading eventually to collapse.

For temperatures higher than 200°C, the stress-strain characteristics of steels change by decreasing the yield stress and the modulus of elasticity. This effect combined with the increase of stresses associated with the temperature elevation leads to the collapse of plates. The European Recommendations [10] are generally used to describe the steel behaviour (see Fig. 1).

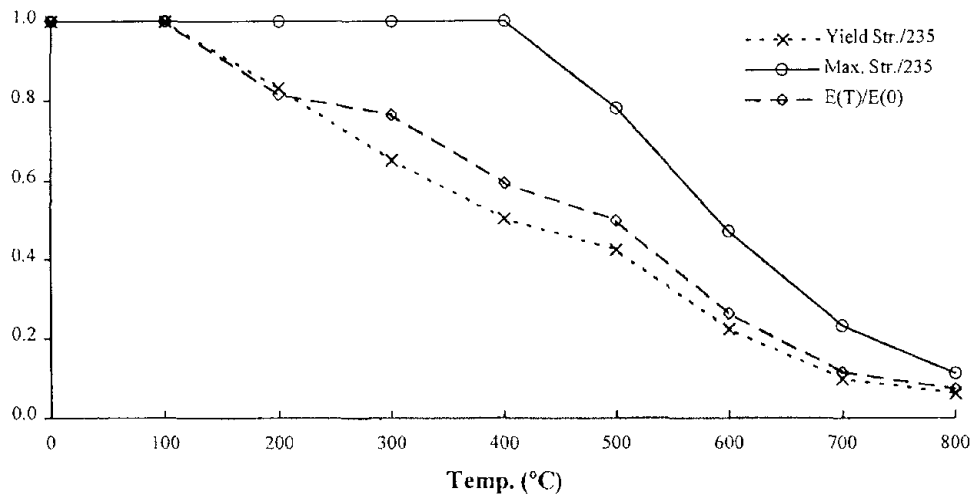

Figure 1. Material properties of mild steel; [10].

At 200°C there is a decrease of the yield and ultimate stresses but the difference between the yield stress and the ultimate stress is not very large. For 400°C, the yield stress is much lower and, though the ultimate stress is very similar to that for 200°, it is only reached at a much larger strain. For 600°C and 800°C there is a very significant decrease in the ultimate stress but again the difference between the yield stress and ultimate stress is small, i.e. the overall behaviour again becomes similar to that at 2000 (See Fig. 2).

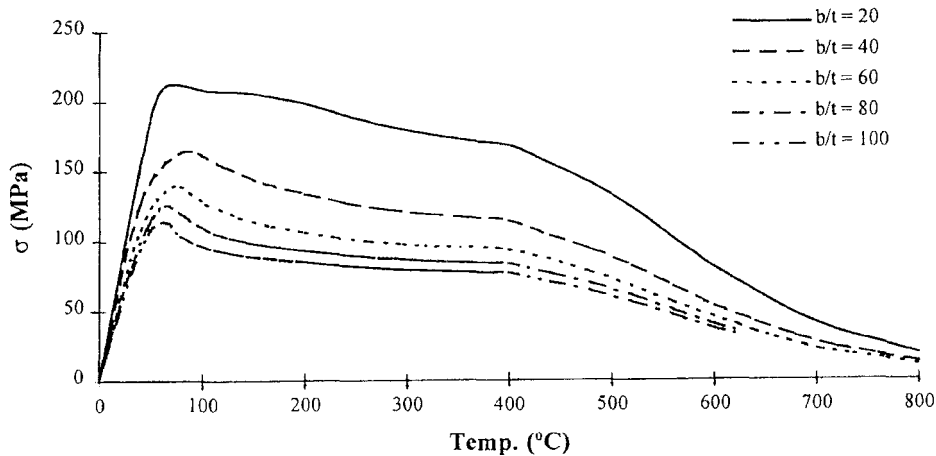

Figure 2. Longitudinal stress-temperature curves of rectangular plates ($a/b=3$) with different slenderness.

At ambient temperature the collapse strength of plates is governed mainly by the plate slenderness, though the boundary conditions, the aspect ratio and the initial distortions are important parameters; [11].

Load shortening curves of plates subjected to the bi-axial loading associated with their temperature increase, were calculated showing the effect of the different parameters that influence the plate collapse. This study has determined the load-shortening behaviour of plates with different aspect ratios, slenderness and initial distortions by using a non-linear finite element code. A proportional displacement was imposed on the edges of the plates and the corresponding edge reactions were calculated.

The loading is a heat source that leads to a monotonically increasing temperature with uniform distribution in the plate, which varies from ambient temperature to values up to 800°C . The assumption of uniform temperature in the plates results from the thermal conductivity of steel which leads to a very quick heat conduction.

The numerical calculations were performed using the ASAS-NL software [12] which takes thermal loads into account. This is a general-purpose non-linear finite element code in which large displacement effects are handled and the element stiffness and the material properties are updated according to the actual thermal load.

Having established that the thermal collapse load of plates is independent of their initial temperature, but only of the temperature increase, a series of calculations was conducted for several plates starting from an initial ambient temperature, subjected to a temperature increase up to collapse and continuing in the post-collapse range. The aspect ratio of the plates was 1 and 3 and the slenderness covered a range from a bit of 20 to 100.

The bi-axial state of stresses is present in all plates especially in the elastic range ($T < 100^{\circ}\text{C}$). Collapse in the transverse direction is reached at a lower temperature and at lower stress levels. After the collapse in the transverse direction, the stresses in this direction fall quickly to very low levels while the longitudinal stresses keep increasing until the longitudinal collapse is achieved.

It was observed that the maximum load carrying capacity of the plates is often reached at temperature differentials ranging from 100°C to 200°C , a region where the yield stress of the material has not decreased too much yet.

The first main conclusion for plates with aspect ratios different from that with a predominant mode of imperfections equal to the length of the plate, is that the collapse in the transverse direction is achieved at lower temperatures ($T = 75^{\circ}\text{C}$) than the collapse in longitudinal direction or the collapse of square plates ($T = 120^{\circ}\text{C}$) in which failure occurs simultaneously in both directions.

The effect of the elastic supports of the plates is important until the collapse of the plate is reached but afterwards it may be ignored. However the “ultimate” strength of the plate, i.e. the maximum of the stress-temperature curve decreases with the reduction of the stiffness of the elastic supports.

3.4 Uncertainty modelling

In the reliability analysis of plated components, the parameters which can be considered as random or uncertain are listed in Table 1, and these are described using appropriate probability density functions.

Category	List of random parameters
Release	Diameter of exit hole or pool size, flow-rate, exit velocity (jet tire)
Fuel	Heat of combustion, temperature of source, combustion temperature
Environment	Wind speed, wind direction, ambient temperature, relative humidity
Fire Model	Uncertainty in flame shape, surface emissive power, and heat flux models
Blast Loading	Intensity of overpressure and uncertainty of blast loading model
Insulation	Thickness, density, thermal conductivity, specific heat, surface emissivity
Steel	Specific heat, surface emissivity, yield strength and Young's modulus
Resistance model	Uncertainty in thermal model and in component strength model

Table 1. List of random basic variables used in reliability analysis

The probability distributions for the above-listed variables should be obtained from statistical data where available. If not, these should be estimated based on judgement and experience. Studies so far have shown that the uncertainties in the sub-models used for fire and blast loading is the most important variables for reliability, and data for these could be obtained by comparing model predictions against experimental results. At present, however, test data for realistic offshore module geometries are not available, but a number of industry funded projects are currently in progress to produce such data.

3.5 Reliability analysis

In studying the stress-temperature curve of plates, it was established that the differential of temperature in a plate will lead to its collapse whenever it reaches the limit value. Therefore, one can define the probability of failure as the probability of the temperature differential in the plate being higher than its limit temperature differential.

The safety margin is then expressed as; see [13]

$$Z = \Delta T_{\text{lim}} - \Delta T_{\text{steel}} \quad (1)$$

where, ΔT_{lim} is the difference of temperature that leads to plate collapse, and ΔT_{steel} is the actual increase of plate surface temperature.

The change of temperature across an insulation material can be calculated as a function of time by a numerical procedure, as a function of the input thermal radiation intensity, which in turn depends on several fire parameters, as indicated in Section 3.2.

It is possible to formulate the reliability problem as a function of the input thermal radiation intensity or as a function of the basic variables that describe the fire.

For simplicity, the first case will be discussed here.

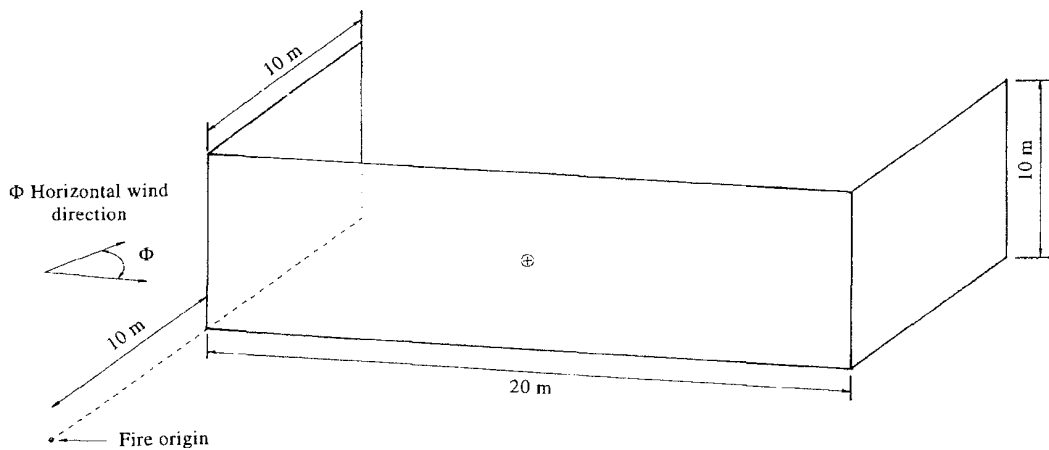

Figure 3. Model analysed.

Since the temperature increase cannot be described by an analytical expression the limit state equation has to include the numerical scheme that yields the temperature increase as a function of the thickness of the insulation (t_i) the thermal conductivity (k_i), the density (ρ_i) and the specific heat Cp_i of the material, in addition to the input thermal radiation intensity. Thus the safety margin equation should be rewritten, as:

$$Z = \Delta T_{\text{lim}} - \Delta T_s(\dot{q}'', t_i, k_i, \rho_i, Cp_i) \quad (2)$$

Fig. 3 shows the model used for reliability analysis of the fire and the position of the fire origin. Two values for the horizontal wind direction are considered. The first value of 45° was adopted in order to obtain the maximum value of radiation in the center of the wall (50.9 kW m^{-2} ; 702°C). The second value of 80° corresponds to a radiation in the center of the wall of 13.9 kW m^{-2} (436°C). Table 2 has the stochastic model used.

Variables		Mean value	s.D.
Rad	Radiation	13.88/50.9	1.39/5.09
t_i	Thickness of insulation	0.020	0.002
K_i	Thermal conductivity	0.05	0.005
ρ_i	Density	2000.0	200.0
Cp_i	Specific heat	500.0	50.0
T_{lim}	Limit temperature	58.9	5.89

Table 2. Stochastic variables

Fig. 4 shows the reliability index that was obtained for the two mean values of radiation 13.88 and 50.9 kW m^{-2} . These values of radiation correspond to the two wind directions mentioned earlier. For the lower radiation value higher values of the reliability index were obtained, as was expected.

4. RELIABILITY OF SKELETAL STRUCTURES

The reliability analysis procedure for skeletal structures follows the same overall approach as used for plated structures. In particular the fire and blast models and heat

transfer models are the same as those described in Section 3. The models used for component and system capacity and the corresponding reliability formulations are discussed later.

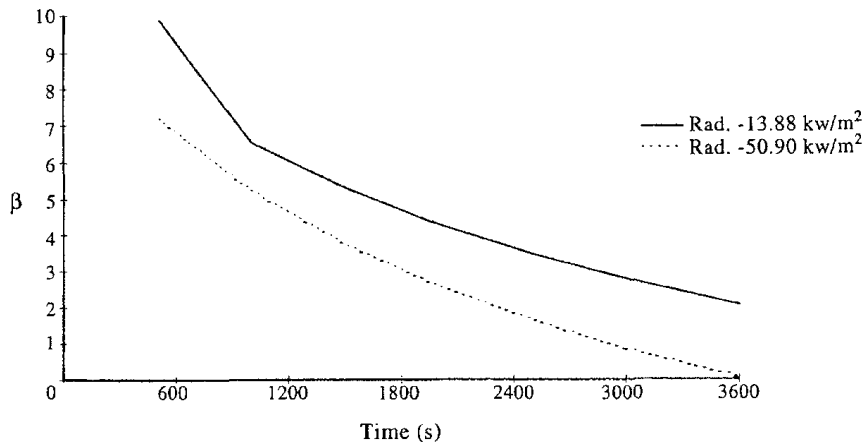

Figure 4. Time-dependent reliability index

4.1 Strength of beam-column elements

The failure equations for time-dependent collapse of beam-column elements (e.g. framing members of tube, I or channel section) were developed based on three alternative formulations:

1. API method [14],
2. ECCS method [15], and
3. elasto-plastic buckling analysis [16].

The models account for temperature-dependent variation of yield strength and elastic modulus.

4.2 Progressive collapse of structural systems

For redundant skeletal structures, the conventional practice of using linear-elastic methods and consideration of single member failure can be unduly conservative. It is important to model the progressive failure of a number of members at different time-steps and determine the time to collapse of the structure as a whole.

The algorithm for progressive collapse analysis is based on the virtual distortion method (VDM) [17]. In this method, “virtual distortions”, which simulate permanent deformation of a structure, are used to model the failure of a member owing to overloading caused by the combined action of gravity, operational and thermal loading. Effects, such as the presence of thermal strains and reduction of the yield strength and elastic modulus with temperature are taken into account. Further, to model accurately the path-dependent collapse sequence, an iterative/incremental computational strategy has been developed. This procedure accumulates incremental changes in internal forces and deformations as the various thermal load increments are applied, allowing simultaneously for the updating of the global stiffness and influence matrices.

The algorithm was implemented in the RASOS software (see [18]) and was verified against the general purpose ASAS-NL non-linear finite element program.

4.3 Component reliability analysis

The probability of failure owing to buckling or yielding at a section of a member can be

expressed as

$$p_f(t) = P[Z(t) \leq 0]$$

$$Z(t) = 1 - \left[\frac{P_a(t)}{P_u(t)} + \sqrt{\left(\frac{M_{ax}(t)}{M_{ux}(t)} \right)^2 + \left(\frac{M_{ay}(t)}{M_{uy}(t)} \right)^2} \right] \quad (3)$$

$P_a, M_a(t) = f(\text{fire loading, thermal and response variables})$

$P_a, M_a(t) = f(\text{fire loading, thermal and response variables})$ where the suffix “a” denotes a force/moment owing to the applied deck loads and fire loads and “u” denotes the corresponding capacity of the member. Note that both the applied force and the member capacity are functions, f , of the uncertain fire loading, thermal and response variables.

The axial and bending capacities of a beam-column member under fire loading can be calculated using the methods mentioned in Section 4.1. The applied forces and moments need to be calculated using a static analysis of the structure. Note that, since the forces in a member are dependent on the thermal strains and stresses in other members of the structure, the failure of a member is a function of the temperatures of all other members in the structure. In evaluating the probability of failure of one member, the fire loading and rise in temperature of all members of the structure exposed to the fire need to be calculated.

The failure probabilities for component failure are calculated using the efficient first-order (FORM) and second-order (SORM) reliability methods [19].

This procedure can be used to evaluate the probability of failure of a member of a structure at any given time, t , after the initiation of fire. This could be useful in the modelling of escalation scenarios involving non-functioning of certain safety-critical equipment, for example a fire-water ring main, owing to the failure of a critical structural member on which it is supported.

4.4 System reliability analysis

A redundant structure fails when a number of components fail, progressively leading to the collapse of the structure. For this case a progressive collapse limit-state has been developed which models the progressive failure of several members leading to the collapse of a structural framing. This can be used to predict the probability of failure of skeletal structures such as module support frame, drilling derrick, bridge, etc.

The failure of a structure (system) through a sequence of member failures can be expressed as an intersection of member failure events and the probability of system failure can be evaluated as

$$P_{f,sys}(t) = P[E_1 \cap E_{2|1} \cap E_{3|1,2} \cap \dots \cap E_{q|1,2,\dots,q-1}] \quad (4)$$

where event $E_{k|i,j}$ denotes the failure of member k following the failure of members i and j in sequence. The safety margin for the j th component failure in the sequence can be expressed in a generalised form as

$$Z_j(t) = R_j(t) - Z_j^{(j-1)} \{ \hat{R}_1, \hat{R}_2, \dots, \hat{R}_{j-1}, \text{fire, thermal, response variables} \}(t) \quad (5)$$

where R_j is the resistance of member j and $S^{(j-1)}$ is the stress resultant in member j after the failure of 1, 2, ..., $(j - 1)$ members in that sequence. Note that the stress resultant is also a function of the post-limit capacity of the already failed members, which is taken

into account in calculating the force re-distribution in the structure following member failures using the VDM approach.

The joint β -point of the intersection surface (which is the most-likely failure point leading to the failure of all the components in the sequence) is located using a multi-constraint optimisation technique based on the NLPQL algorithm (see Ref. [20]).

In view of the uncertainties involved in fire loading and component capacities, a structure can fail through a number of potential combinations of component failures, called “failure paths”. In practice, it was observed that only a small number of failure paths contribute most to the system failure probability.

One of the main tasks in SRA is the identification of, so called, “probabilistically most-likely” failure paths for a structure. This is achieved using the Selective Enumeration Method (see Ref. [21]). This approach uses a number of criteria such as conditional safety margin (for the next failure element in the sequence), the reliability index at the previous branch point and the correlation between failure paths to minimise the number of branches enumerated at each branch point. The failure paths are identified in the order of their importance (i.e. the most-likely failure path is identified first and the next most-likely second etc.), and the failure tree enumeration is stopped when the difference between the upper bound and lower bound on system reliability becomes acceptably small.

The failure of the structure can, occur through any of the dominant failure paths. The system failure event can, therefore, be defined as the union of all failure paths and the system failure probability can be evaluated as

$$P_{f,sys}(t) = P \left[\bigcup_{k=1}^N F_k \right] \quad (6)$$

where, F_k denotes the event “failure through k th failure path”.

The probability of failure for a failure path as given by eqn (2) is calculated using an “advanced FORM” approach in which the intersection failure domains are linearised at the joint β -point. The intersection probability is evaluated using a multi-normal integral taking into account the correlations between component failure events (see Ref. [20] for details).

The union over all complete failure paths (which resulted in structural collapse) identified during failure-tree enumeration gives the upper-bound on system failure probability, while the union over all incomplete failure paths (which did not result in structural collapse) gives the lower-bound. The probabilities of union events are calculated using a multi-normal integral taking into account the correlations between failure paths.

A realistic case study of the system reliability methodology applied to an offshore platform under jet fire conditions was presented in Ref. [22].

5. OPTIMISATION OF FIRE PROTECTION

Until recently, the design of active and passive fire protection on offshore topsides was governed by prescriptive rules which did not take into account the specific hazards experienced by a platform, and by different parts of the topside. This has resulted in high costs without a commensurate increase in safety. With the “goal setting” approach introduced by recent UK Health and Safety Executive regulations [1], fire protection can be designed to meet performance standards for individual systems and hazard scenarios.

Within the OFSOS project, a reliability-based optimisation technique has been developed for the design of thermal insulation. The procedure minimises overall costs while satisfying performance standards which are specified in terms of “maximum acceptable probability of failure” as opposed to the commonly used deterministic “endurance Times” criteria.

The objective function of optimisation is the minimisation of “total expected cost” which includes initial cost and maintenance costs of the protection system and cost of failure of the platform (loss of life, loss of asset and environmental damage) multiplied by its probability of failure. The optimisation is subject to constraints on specified levels of safety for members of the structure.

The design variables can be the layout and the type of passive fire protection (PFP) material and thickness of insulation. The effect of active fire protection (AFP) and other mitigation measures is taken into account by repeating the PFP optimisation for different trial values of AFP and other mitigation measures. The analysis is carried out for different scenarios relevant for the components being protected and the maximum value of PFP is selected. The methodology and software for optimisation of fire protection is described in the following.

5.1 Steps in the optimisation process

The optimisation methodology consists of number of steps, see Fig. 5. Not all steps are obligatory.

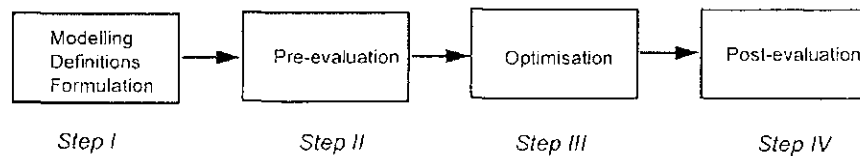

Fig. 5. Steps in the optimisation process.

5.1.1 Step I: modelling, definitions and formulation

This first step consists of a number of actions such as selection of the structural model, definition of an FEM model, grouping of structural elements, definition of fire scenarios, definition of failure modes, corresponding limit states, and the stochastic modelling.

5.1.2 Step II: pre-evaluation

This pre-evaluation step is very useful. In many cases the optimisation of PFP can be performed using only the pre-evaluation modules. In the pre-evaluation: a FEM analysis of the structure is performed and the potential failure modes are evaluated, the structure is modified if one or more limit states are violated, a sensitivity analysis is performed to obtain a feasible design without re-analysis of the structure, design variables are added or removed based on the results of the sensitivity analysis, and the corresponding deterministic optimisation problem is solved. Next, the reliability index and its derivatives are calculated so that limit states, stochastic variables etc. may be deleted/added.

5.1.3 Step III: optimisation

This is the main step in which the design variables, objective function and constraints are formulated (see below) and the reliability based optimisation problem is solved.

5.1.4 Step IV: post-evaluation

In this step, the optimisation results may be modified, e.g. rounding up of some design variables to the nearest allowable value, and the optimisation results are evaluated to ensure that all assumptions are valid. If not, a new grouping of elements or the use of a new PFP material may be considered and a new optimisation performed, i.e. the optimisation is repeated from the beginning.

5.2 Formulation of the problem

The reliability-based optimisation problem can be formulated in the following way.

$$\begin{aligned}
 & \min_{\bar{b}} C(\bar{b}) \\
 & \bar{b}^T = (b_1, \dots, b_n) \\
 & s.t. \quad \beta_j(\bar{b}, \bar{x}, t, s_i) \geq \beta_j^{\min} \quad , \quad j = 1, \dots, M \\
 & \quad \beta^{\text{sys}}(\bar{b}, \bar{x}, t, s_i) \geq \beta^{\text{sys}, \min} \\
 & \quad b_i^{\min} \leq b_i \leq b_i^{\max} \quad , \quad i = 1, \dots, n
 \end{aligned} \tag{7}$$

where C is the objective function (cost function) and $\bar{b}^T = (b_1, \dots, b_n)$ are the design variables, s_i is fire scenario i , and t is the reference time. The reference time could be the time where the fire is maximum or the time to evacuate all personnel. \bar{x} is a vector of stochastic variables, M is the number of constraints and n is the number of design variables.

The solution to this problem is \bar{b}_{opt}^i where the superscript indicates scenario i . Problem (7) is solved for all n scenarios and the maximum value for each design variable from any scenario is used as the final solution.

The optimisation algorithms for non-load bearing fire-walls and structural beam-column members are summarised in the following.

5.3 Optimisation of firewalls

It is assumed that the geometry of the fire wall is constant and only the insulation on the hot side of the firewall is optimised. There are only two design variables for a fire wall, namely the thermal conductivity of the PFP material and the thickness of the insulation material. The objective function is the cost of the PFP modelled as a function of the thickness and of the thermal conductivity and a constant term related to the installation.

A constraint is, in the deterministic case, imposed on the temperature at the interior face of the insulation, which at the reference time t (e.g. 60 min for A60 walls and 90 min for A90 walls) must be lower than some specified limit state temperature. In the reliability based formulation, the constraints are related to the probability that the temperature in the firewall exceeds a limit value. This methodology has been implemented in the OPTIWALL module of the OFSOS software. Figs 6 and 7 show the output screens from a real application using OPTIWALL.

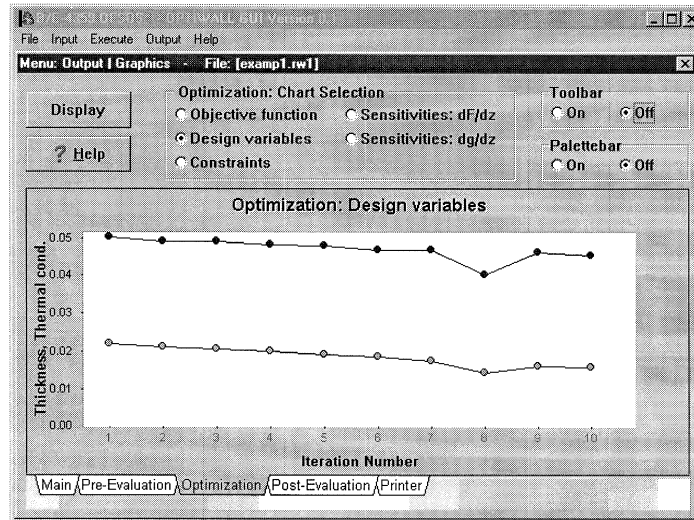

Fig. 6. OPTIWALL. Optimization: History of the design variables.

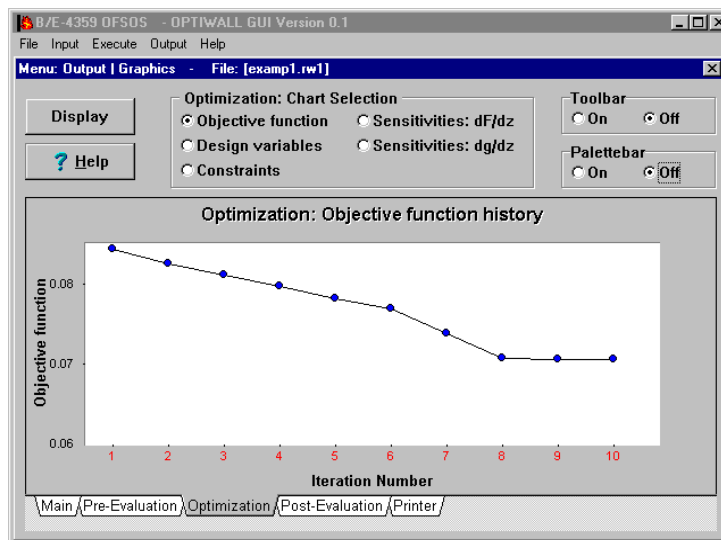

Fig. 7. OPTIWALL. Optimization: history of the objective function (cost of PFP).

5.4 Optimisation of PFP on skeletal structures

The algorithm for the optimisation of PFP on framing members of a skeletal structure has been implemented in the OPTIBEAM module of the OFSOS software. OPTIBEAM combines models for reliability with optimisation models to perform deterministic and reliability-based optimisation of PFP applied to structural members. The design variables are the thickness of the PFP on framing members. Since the number of structural elements on a standard topside structure may be quite large, OPTIBEAM allows the grouping of PFP on different members into a small number of groups in order to reduce the number of design variables. In order to take into account the effect of other mitigation measures (AFP, improved lay-out, etc.) a third term may be included in the objective function. The objective function is the sum of the total cost of PFP and the expected failure costs. Constraints are related to a limiting temperature failure criteria or to member failure by buckling/yielding.

At the present time the optimisation is performed considering the failure of single components. Although the consideration of system failure is theoretically straightforward, the computer resources required for this (especially using system reliability constraints) are considered to be prohibitively large.

6 SUMMARY AND CONCLUSIONS

The “goal-setting” natures of recent regulations in the major hydrocarbon producing countries in Europe require an explicit identification and assessment of all hazards to offshore installations. QRA techniques are now increasingly used for the assessment of fire and blast hazards to an offshore structure and for the effective planning of remedial/mitigation measures. Although these methods provide a good overall framework, improvements are considered necessary in a number of areas, especially in the treatment of uncertainties involved in fire and blast load estimation and their effects on safety-critical systems on the platform. Until now, consequence modelling has been largely deterministic.

Within the OFSOS project, some of these deficiencies have been overcome by developing a unified and consistent approach to fire safety assessment and optimisation of fire protection. This was achieved by integrating conventional risk analysis techniques with the modern methods of structural reliability analysis and RBDO.

Central to this unified approach are the methodologies for the evaluation of probabilities of failure of structural components and systems, and the methodology for the optimisation of fire protection, which form the focus of this article.

Structural reliability methods were proposed for calculating the probabilities of events involving the failure of components or systems for which historical failure frequency data are not available. These methods explicitly take into account the major sources of uncertainties in the data and calculation models used for fire and blast loading and the inherent variability in fire parameters, environmental variables and material properties.

A reliability-based optimisation approach was presented for the optimal design of passive fire protection on offshore topsides. The procedure aims to minimise the expected total cost, which includes initial cost and maintenance costs of the protection system and cost of failure of the platform, while satisfying constraints on specified levels of safety for components of the structure.

In conclusion, it can be said that the OFSOS methodology significantly enhances conventional QRA techniques by providing additional models and tools for the quantification of uncertainties involved in fire and blast loading and for the evaluation of failure frequencies of components and systems for which historical data are not available. This enables a rigorous modelling of escalation paths leading to catastrophic events such as loss of escape routes, loss of TR and evacuation facilities, so that effective control and mitigation measures can be designed to reduce the risks. It also enables a more consistent formulation of risk-based performance standards at all three levels: for the overall platform, for individual hazard scenarios and for individual systems and components.

ACKNOWLEDGEMENTS

The work described in this paper has been carried out under the CEC BRITE-EURAM Project 4359, “OFSOS: Optimised Fire Safety of Offshore Structures”, 1992-1995. The

main partners in the project are WS Atkins (UK), AEA Technology (UK), Computational Safety and Reliability (Denmark), Germanischer Lloyd (Germany), Instituto Superior Tecnico (Portugal), Registro Italiano Navale (Italy), Snamprogetti (Italy), and Tecnomare (Italy). The project has been 50% funded by the CEC and the balancing funds have been provided by the partners themselves and four industrial sponsors: AGIP (Italy), Amoco (UK), British Gas (UK) and Chevron (UK). The financial support from these organisations and the technical contribution of all participants in the project is gratefully acknowledged.

REFERENCES

- [1] Health and Safety Executive, Offshore Installations (Safety Case) Regulations, SI 1992. No. 2885, HMSO, 1992.
- [2] Health and Safety Executive, Offshore Installation.(Prevention of Fire and Explosion. Emergency Response) Regulations SI 1995, No. 743, HMSO, 1995.
- [3] United Kingdom Offshore Operators Association UKOOA, Fire and Explosion Hazard Management Guidelines, 1995.
- [4] Shetty, N. K., Deaves, D. M., Gierlinski, J. T. and Dogliani, M., Unified methodology for fire safety assessment and optimal design, Proceeding of the 15th International Conference on Offshore Mechanics and Arctic Engineering, Florence, Italy, ASME, New York, 1996, Vol. II, pp. 359-369.
- [5] Thomas, P. H. and Karlsson, B., On the length of flames under ceilings. *Journal of Fire Sciences*, 1991, 9, Nov-Dec, pp. 527-537.
- [6] Chamberlain, G A., Developments in design methods for predicting thermal radiation from flares. *Chemical Engineering Research and Design*, 1987, 65, pp. 299-309.
- [7] Guedes Soares, C., Teixeira, A. and Neves, L., Probabilistic modelling of offshore pool fires. In *Advances in Safety and Reliability*, vol. 2, Ed. C. Guedes Soares. Pergamon, 1997, pp.781-790.
- [8] Cabbage, P. A. and Simmonds, W. A., An investigation of explosion reliefs for industrial drying ovens, I-top reliefs in box ovens. *Transactions Institution of Gas Engineers*, 1955, 105, pp. 470-480.
- [9] Guedes Soares, C., Gordo, J. M. and Teixeira, A. P., Elasto-plastic collapse of plates subjected to heat loads. *Journal of Constructional Steel Research* (accepted for publication).
- [10] Commission for the European Communities, Eurocode n. 3 (EC3): design steel structures, part 10. *Structural Fire Design*, draft, 1990.
- [11] Guedes Soares, C. Design equation for the compressive strength of unstiffened plate elements with initial imperfections. *Journal of Constructional Steel Research*, 1988, 9, 287-310.
- [12] WS Atkins Engineering Sciences Ltd, ASAS NL, Version 19, UK, 1990.
- [13] Guedes Soares, C., Teixeira, A. and Lopes, J. B., Reliability of plate elements subjected to offshore pool fires. Presented at ICOSSAR '97, Japan, 1997.
- [14] American Petroleum Institute, Recommended practice for planning, designing and constructing fixed offshore platforms-working stress design. In *APIRP 2A-WSD*, 20th edition, 1993.
- [15] ECCS-Technical Committee 3, European Recommendations for the Fire Safety of Steel Structures. Elsevier, 1983.

- [16] Abbassian, F., Lau, T.B. and Zintilis, G. M., 3-D inelastic behaviour of tubular members supported on non-linear rotational springs. Proceedings of the 8th International Conference on Offshore Mechanics and Arctic Engineering, Hague, The Netherlands. ASME, New York, 1989, vol. 2.
- [17] Holnicki-Szulc, J. and Gierlinski, J. T., Structural Analysis, Design and Control by the Virtual Distortion Method. Wiley, 1995.
- [18] WS Atkins, RASOS-Software Architecture and Computational Features, Report No. WSA/M1773.001, Issue 4, 1994.
- [19] Madsen, H.O., Krenk, S. and Lind, N. C., Methods of Structural Safety. Prentice-Hall Inc., Englewood Cliffs, NJ, 1986.
- [20] Shetty, N. K., System reliability of offshore structures under fatigue deterioration. Ph.D Thesis, Imperial College, University of London, 1992.
- [21] Shetty, N. K., Selective enumeration method for identification of dominant failure paths of large structures. In Proceedings of the 13th International Conference on Off-shore Mechanics and Arctic Engineering, Houston, Texas. ASME, 1994, vol. 2, pp. 381-392.
- [22] Shetty, N. K. Gierlinski, J. T., Liew, S. K. and Mitchell, B.H., Reliability of an offshore topside under pool and jet fire conditions. In Proceedings of the 15th International Conference on Offshore Mechanics and Arctic Engineering, Florence, Italy. ASME, New York, 1996, vol. 2, pp. 379-386.