



AALBORG UNIVERSITY
DENMARK

Aalborg Universitet

Low Frequency Hearing Thresholds in Pressure Field and in Free Field

Watanabe, Toshio; Møller, Henrik

Published in:
Journal of Low Frequency Noise, Vibration and Active Control

Publication date:
1990

[Link to publication from Aalborg University](#)

Citation for published version (APA):
Watanabe, T., & Møller, H. (1990). Low Frequency Hearing Thresholds in Pressure Field and in Free Field. *Journal of Low Frequency Noise, Vibration and Active Control*, 9(3), 106-115.

General rights

Copyright and moral rights for the publications made accessible in the public portal are retained by the authors and/or other copyright owners and it is a condition of accessing publications that users recognise and abide by the legal requirements associated with these rights.

- Users may download and print one copy of any publication from the public portal for the purpose of private study or research.
- You may not further distribute the material or use it for any profit-making activity or commercial gain
- You may freely distribute the URL identifying the publication in the public portal -

Take down policy

If you believe that this document breaches copyright please contact us at vbn@aub.aau.dk providing details, and we will remove access to the work immediately and investigate your claim.

Low Frequency Hearing Thresholds in Pressure Field and in Free Field

Toshio Watanabe* and Henrik Møller

*Institute of Electronic Systems, Aalborg University, Fredrik Bajers Vej 7, DK-9220
Aalborg Ø, Denmark.*

** now at Fukushima National College of Technology, Iwaki, Fukushima, 970, Japan.*

Received 2nd April 1991.

SUMMARY

Thresholds of hearing were determined in pressure field at frequencies from 4 Hz to 125 Hz. At the frequencies 4-25 Hz hearing thresholds were found that are in the lower middle of the range already reported by other investigators.

At frequencies from 25 Hz to 1 kHz thresholds have already been determined in free field by the same method and using the same subjects. The two investigations overlap at frequencies from 25 Hz to 125 Hz, and in this range the results were almost identical. The differences were below 1 dB, except at 63 Hz where the difference was 2.5 dB. None of the differences was significant in a t-test.

1. Introduction

Thresholds of hearing at frequencies below 100 Hz and down to frequencies as low as 2 Hz have been measured by various investigators. Pressure stimuli were used rather than free field. The sound was either transmitted to the ear by means of a headphone [1,2,3,5] or the whole body was exposed in a pressure chamber [3,4,5,6]. The results show considerable variation between studies, and additional data are required.

For the frequency range down to 20 Hz, free field data also exist, i.e. from ISO/R226[9] and from a recent investigation by ourselves [8]. Free field data differ from pressure data in the sense that the values reported are sound pressure levels in a plane wave, measured without the listener present. Due to diffraction around the body and head, this is not the exact pressure delivered to the ear when the subject enters the sound field. Pressure field data are actual pressures presented to the ear.

In general the pressure field threshold that are reported at 20-100 Hz are higher than the free field thresholds of ISO/R226 [9] and those reported by ourselves [8]. However, at these frequencies little diffraction is caused by the listener's head and body, and it is doubtful whether the difference in sound field can explain the difference.

The present investigation was carried out in order to obtain new threshold data in the very low frequency region and to clarify whether the above mentioned discrepancies are real differences in thresholds caused by different sound fields, or artifacts caused by differences in method, criteria, subjects or other factors.

The investigation consisted of a duplication of our previous threshold determinations [8], using the same subjects and repeating everything as closely as possible, except for the sound field which was replaced by a pressure field. Thanks to the pressure field lower frequencies - down to 4 Hz - could be included.

2. Pressure Exposure Chamber

2.1 Description of the chamber

The infrasound test chamber at the Institute of Electronic Systems of Aalborg University was used for the measurement. The chamber was built for the infrasonic exposure of humans. It was designed for a previous study [7] but reconstructed in 1987 because of the removal of the Institute to a new campus. The size of the new chamber is almost the same as the previous one, but the number of loudspeakers has been increased.

Fig. 1 shows a ground plan and an elevation of the chamber. The volume is 16.2m³.

LOW FREQUENCY HEARING THRESHOLDS

To further check the air tightness, sound pressure levels were measured in the centre of the chamber with sinusoidal excitation at frequencies down to 0.05 Hz. Fig. 2 shows the sound pressure level in the chamber as a function of frequency for a constant output level from the power amplifier.

A lower 3 dB frequency at 0.2 Hz was confirmed by this method. Accordingly sound can be generated effectively for frequencies above approximately 0.2 Hz. If the air inlets and outlets of the ventilating system are blocked, the lower limiting frequency becomes even lower.

2.4 Background noise

The background noise in the infrasound test chamber is very low, even when the ventilating system is working. However, the loudspeakers generate some hum noise, when the power amplifier is connected and switched on. The total background noise is shown in Fig. 3 together with the minimum audible field from ISO/R226.

The levels at 50 Hz, 160 Hz and 315 Hz are much higher than the levels of adjacent bands. This is due to hum from the power amplifier. However, levels are still below the thresholds of ISO/R226 except at 315 Hz, where it is 3 dB higher. The noise is audible but very soft. The present investigation deals only with frequencies up to 125 Hz, and the human ear can easily distinguish these low frequencies from frequencies around 300 Hz. As downward masking is also not expected, the subjects would not be disturbed by the 300 Hz noise, and the background noise is considered low enough for determinations of the hearing threshold.

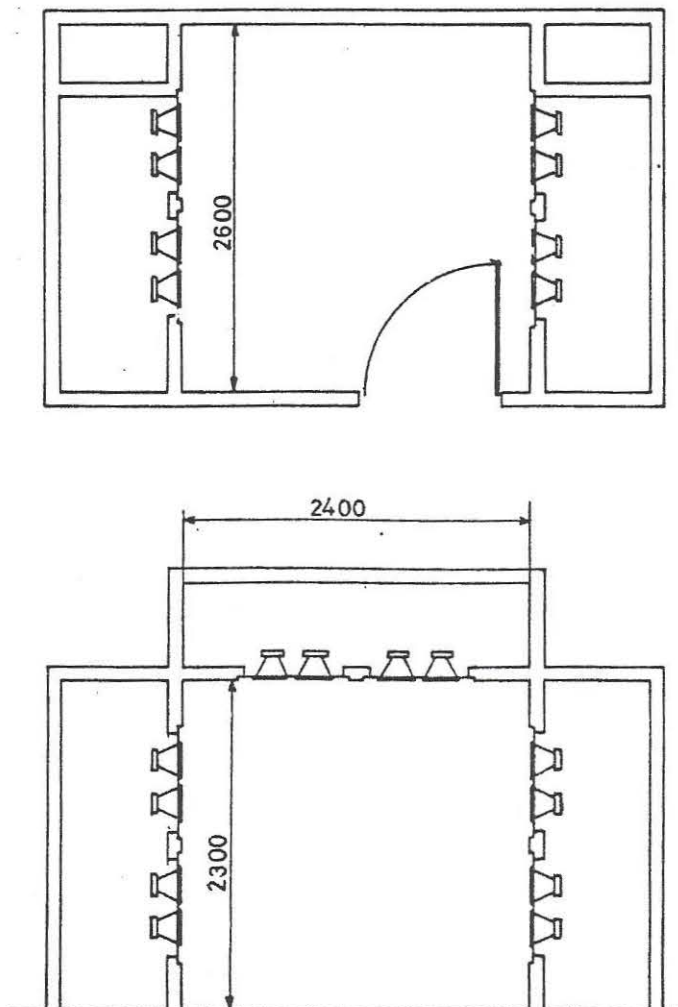

Fig 1. Ground plane and side view of infrasound test chamber.

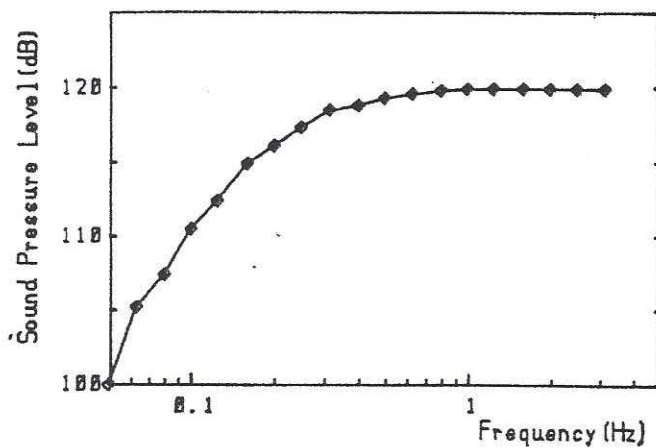

Fig 2. Frequency response of the infrasound test chamber for a fixed output voltage from the power amplifier. The measurement point was in the middle of the chamber.

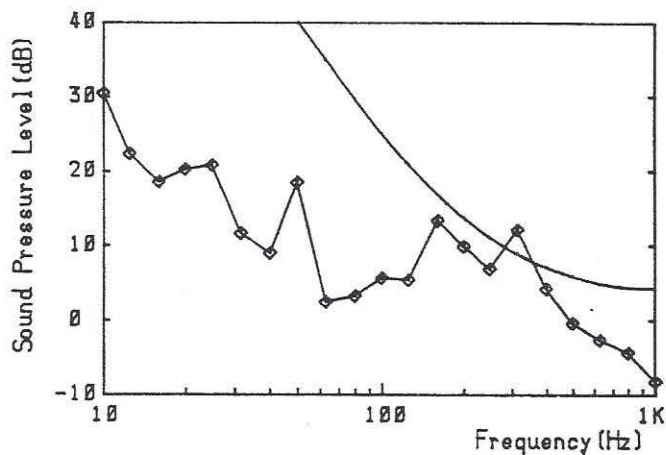

Fig 3. Total background noise in the infrasound test chamber. Measured with Bruel and Kjaer equipment (microphone 4179, preamplifier 2660, analyzer 2131). The line is the minimum audible field of ISO/R226.

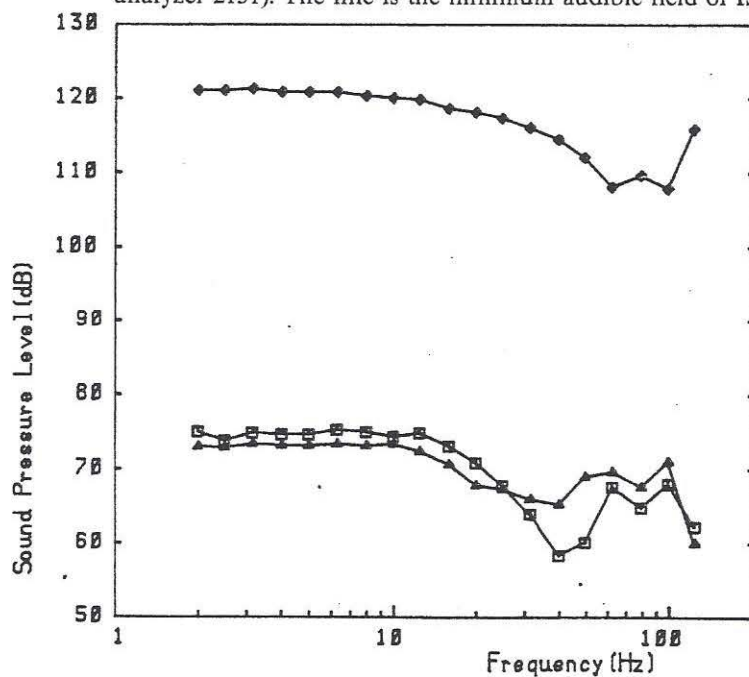

Fig 4. Frequency response and harmonic distortion from the loudspeakers for a fixed output voltage from the power amplifier. The measurement point was in the centre of the room. (◇) fundamental, (□) second harmonic, (Δ) third harmonic.

The walls are double and made of concrete, and the double door is made of steel. The sound insulation is fairly good. Sound absorbing material is attached to the surface of the walls, so that sound reflection is small at high frequencies. A ventilating system is installed and was working while the experiments were carried out.

2.2 Loudspeakers

48 loudspeakers are installed on two walls and the ceiling. Each of these surfaces has 16 loudspeakers, mounted in four rows of four. The diameter of each loudspeaker is 13 inches. Acoustically transparent screens are put in front of the loudspeakers to protect and to conceal them.

2.3 Lower limiting frequency

The rigidity of the walls and the airtightness of the chamber are so good that the chamber serves as a pressure chamber in the low and infrasonic frequency range. To check the air tightness the time constant was measured. A rectangular signal was applied to the loudspeakers and the sound pressure in the centre of the chamber was measured. A time constant $\tau = 0.75$ s was found and a lower limiting frequency can be estimated as $1/(2\pi\tau) = 0.2$ Hz.

2.5 Harmonic distortion

Fig. 4 shows the frequency response and the second and third order harmonic distortion, of the loudspeakers in the chamber. It was measured in the centre of the room and for a constant output voltage from the power amplifier. The sound pressure level of the fundamental is about 120 dB and the frequency response almost flat up to 30 Hz.

The harmonic distortion is fairly low. The second harmonic is more than 45 dB below the fundamental, except at 63 and 100 Hz where it is 40 dB below. The third harmonic is also more than 45 dB down, except at the frequencies 50-100 Hz where values around 40 dB were found.

Harmonic distortion disturbs the measurement of hearing thresholds, since the higher harmonics appear at frequencies where the ear is more sensitive, due to the negative slope of the threshold curve versus frequency. Determination of the threshold at 20 Hz is considered the situation that tolerates the smallest content of higher harmonics. Second harmonic distortion below -36 dB relative to the fundamental and a third order distortion below -47 dB are necessary to ensure that the harmonics are at least 10 dB below threshold (using the slopes of ISO/R226).

The minimum audible field of ISO/R226 is approximately 75 dB at 20 Hz. The harmonic distortion decreases dramatically when the level decreases below the 110-120 dB of Fig. 4, and the harmonic distortion of the loudspeakers is considered sufficiently low for the measurements.

2.6 Sound distribution

Sound distribution in the infrasound test chamber is illustrated in the following figures. The coordinate axes used are shown in Fig. 5.

Considering sound levels along the horizontal line ($y = 1.3$ m, $z = 1.2$ m), shown in Fig. 6, it is seen that the sound distribution is almost even at the lowest frequencies. With increasing frequency a standing wave pattern becomes more prominent. The pattern is almost symmetrical as could be expected from the symmetry of the room and the loudspeakers.

Even at the higher frequencies variations are very small in the middle of the room, where the subject's head is positioned.

The distribution along a vertical line ($x = 1.2$ m, $y = 1.3$ m) is shown in Fig. 7. A less favourable picture is seen. As could be expected since there are only loudspeakers in the ceiling and not the floor, the standing wave patterns are not symmetrical.

Relatively flat curves are seen around the head position in the middle of the room, except for the frequencies 63 Hz and 80 Hz.

In addition to the curves shown, the sound level was measured at positions ± 0.15 cm up/down, left/right and forward/backward from the reference point (head position of the subject during the experiment, $x = 1.2$ m, $y = 1.3$ m, $z = 1.2$ m). Deviations were

LOW FREQUENCY HEARING THRESHOLDS

below 1 dB except for the up/down direction at 63 and 80 Hz, where values around 4 dB were found at 63 Hz and around 2 dB at 80 Hz.

In order to demonstrate how much the uneven pressure distribution would affect the pressure actually presented to the ear of a subject, measurements were carried out with a head and torso simulator (Bruel and Kjaer Type 4128).

The difference between the sound pressure level measured at the pinna of the simulator and the level measured at the head position without the simulator present is given in Fig. 8. For frequencies below 315 Hz, the differences are below 1 dB, which shows that the presence of a subject does not disturb the sound field. On this basis it was concluded that the exposure chamber is adequate for pressure field experiments.

Curves similar to Fig. 8 but for the free field situation were given in our previous paper [8]. For the frequencies involved in the present study - that is, at or below 125 Hz

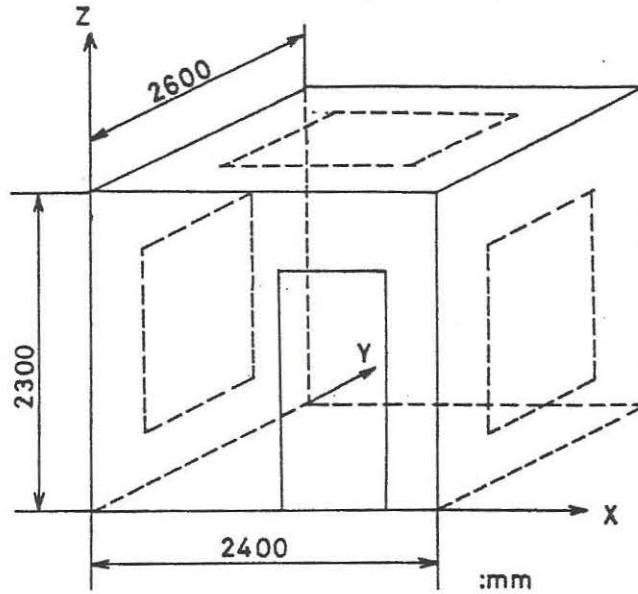

Fig 5. Coordinate axis to express positions inside the chamber

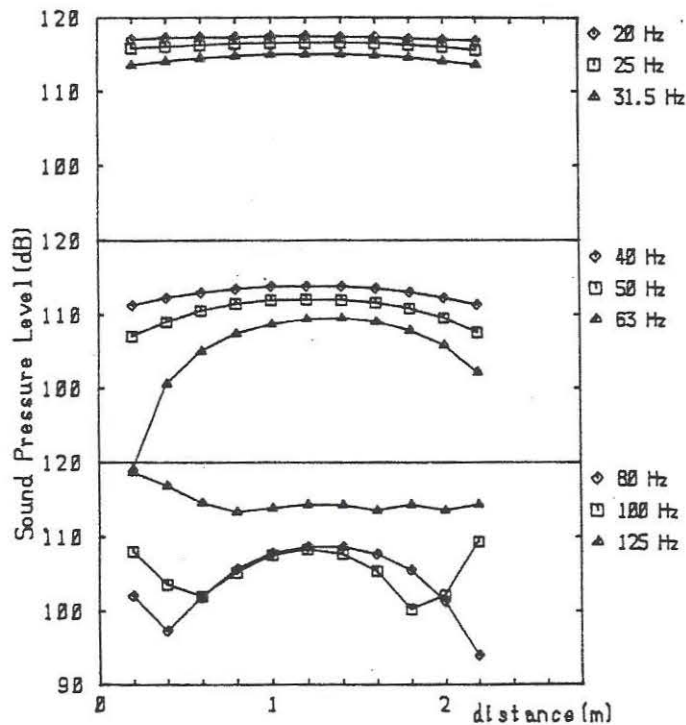

Fig 6. Sound distribution in the chamber. The measurement points are along a horizontal line ($y=1.3$ m, $z=1.2$ m). Distance is the x axis.

LOW FREQUENCY HEARING THRESHOLDS

- the differences between the pressure field and the free field are very small and never exceed 1 dB. Thus, the actual pressure presented to the ear of a subject is the same in the pressure chamber exposure as in the free field situation. From this it is suggested that the hearing threshold will be the same for the two situations.

3. Experiment

Pure sinusoidal tones were used as sound stimuli. They had a duration of 1 s, alternating with 1 s pauses. The tones were turned on and off gradually over approximately 0.25 s. The frequencies were 4 Hz and all 1/3 octave frequencies in the interval 8-125 Hz - fourteen points.

The psychometric method was the method of limits. The procedure method was the method of limits. The procedure was similar to that which was used for the previous measurements of hearing thresholds in the free field. Fig. 9 shows the schematic diagram of the experiment.

The subjects used in the experiment were exactly the same as those used in the experiment for the hearing threshold in free field.

4. Results

Hearing thresholds in the pressure field are given in Table I. For one subject a value at 4 Hz was not obtainable, because the loudspeaker system could not produce a sufficiently high sound pressure. The results are shown graphically in Fig. 10, where also the free field data of our previous study are given.

5. Discussion

5.1 Comparison of hearing thresholds in the free field and in the pressure field.

In the frequency region where pressure chamber data as well as free field data are available, the results are very similar. The differences are below 1 dB, except at one frequency, where the difference is 2.5 dB. Even in that case, a t-test shows no significance ($t=1.6$). Consequently, hearing thresholds in the free field and in the pressure field are the same for frequencies below 125 Hz.

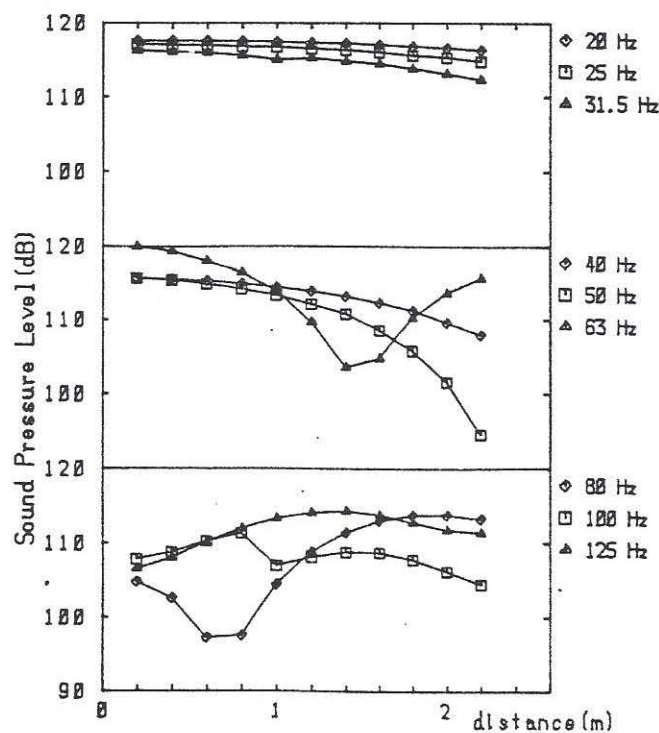

Fig. 7. Sound distribution in the chamber. The measurement points are along a vertical line ($x=1.2$ m, $y=1.3$ m). Distance is the z axis.

LOW FREQUENCY HEARING THRESHOLDS

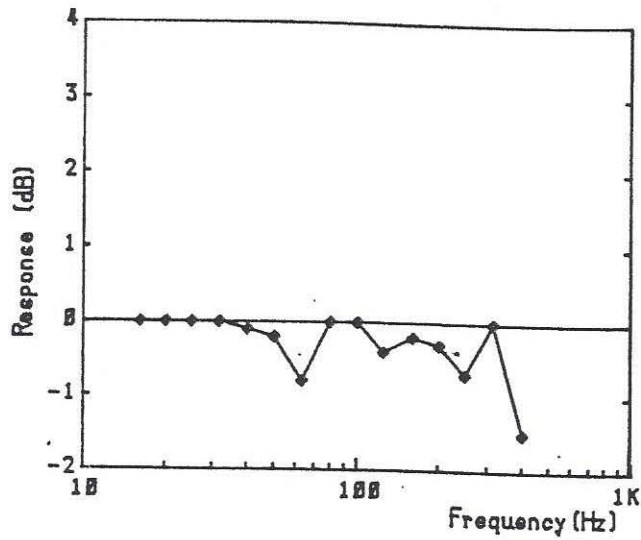

Fig 8. Difference in sound level between the pinna of the head and torso simulator and the head position without the simulator.

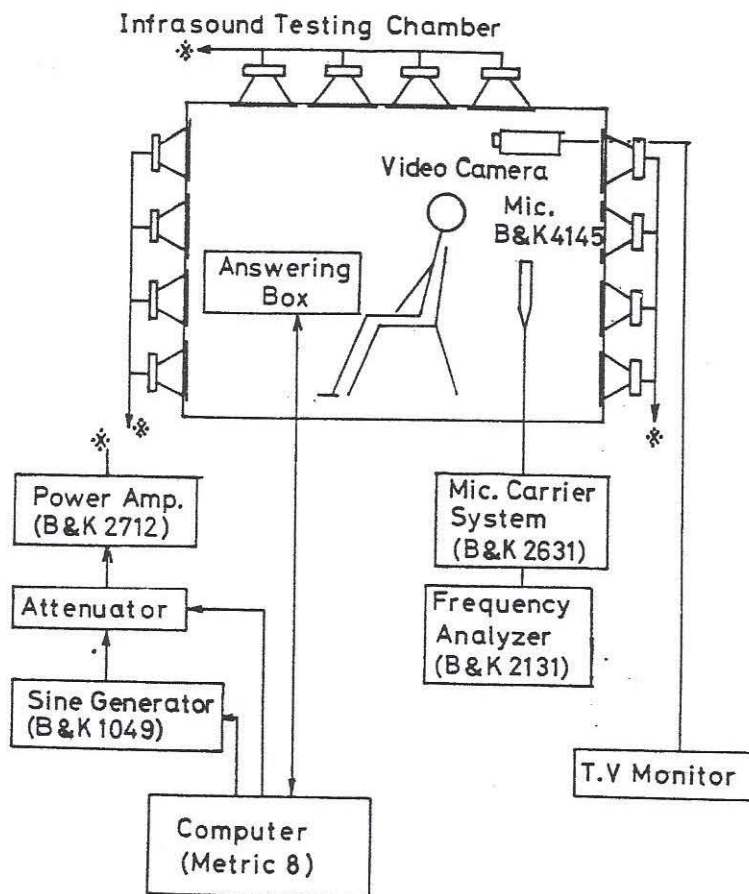

Fig 9. Schematic diagram of the experimental set-up.

LOW FREQUENCY HEARING THRESHOLDS

The dashed line in Fig. 10 is the threshold curve of ISO/R226. The pressure chamber data of the present study support the observation from our earlier study that the curve of the standard does not correspond to the threshold for a group like ours.

5.2 Comparison of hearing thresholds from the present study and from others

Hearing thresholds at low frequencies have been determined by various investigators. Some of the data are shown in Fig. 11 together with our results (since we have shown above that there is no difference between our pressure field and free field data, our results are presented as the average of the two).

Our results are not far from most of the results given by other authors. The curve of Tokita et al. [5] is parallel to ours, but 3-5 dB lower at all frequencies. Their experiment was carried out in an infrasound test chamber whose size was almost the same as ours, and the background noise was as low.

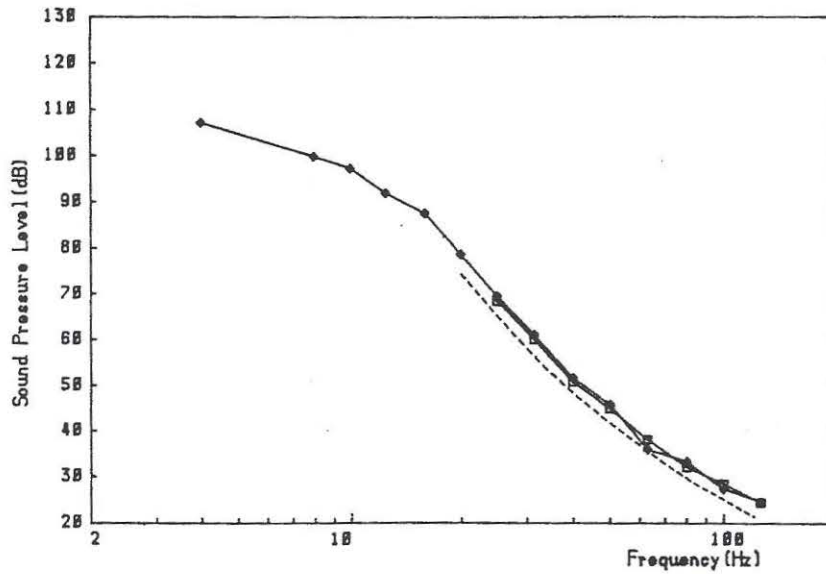

Fig 10. Hearing threshold in pressure field, present study (\diamond) and free field, previous study [8] (\square). The dashed line is ISO/R226.

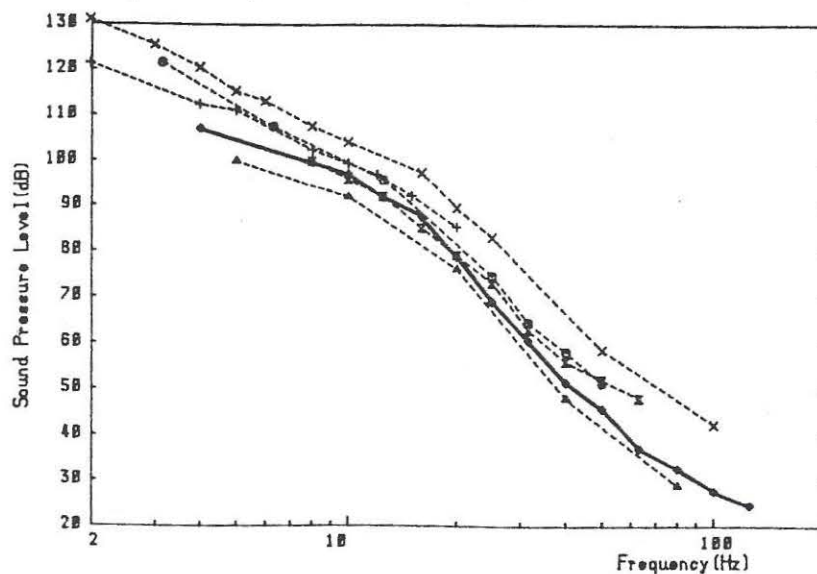

Fig 11. Comparison of threshold data. Tokita et al. [5] (pressure chamber) (Δ); Yamada et al. [6] (pressure chamber) (\times); Yeowart et al. [2] (monaural earphone) (x); Yeowart et al. [3] (pressure chamber) ($+$); Whittle et al. [4] (pressure chamber) (o); our data: average of present study (pressure chamber) and earlier study (free field) (\diamond).

LOW FREQUENCY HEARING THRESHOLDS

The results of Yamada et al. [6] are almost equal to ours at frequencies below 31.5 Hz, but increasing differences appear at higher frequencies. The chamber used in their experiment was small and located inside a normal room. There might have been audible background noise at the highest frequencies. Their article does not give information on this matter.

The pressure chamber results of Yeowart et al. [3] and the data of Whittle et al. [4] show curves that are almost parallel to ours, but values are a few dB higher. At 4 Hz, though, the difference becomes larger.

The monaural earphone data of Yeowart et al. [2] are in general much higher than ours, although they show the same shape of the curve.

Some uncertainty is related to our point at 4 Hz, which may explain the large difference at this point between our point and the data given by Yeowart et al. (pressure chamber data) and by Whittle et al.

The sinusoidal tone is switched on and off by gating with a time window of 1 s and rise and decay times of approximately 0.25 s. In the frequency domain this signal turns out somewhat broader than a pure sinusoidal tone. Thus the exposure extends from 4 Hz towards higher (and lower) frequencies, and because of the slope of the threshold curve, the measured threshold will be too low. This effect exists theoretically at all frequencies, but is only considered as a source of error at 4 Hz, since here especially the time window is short compared to the time period of the sinusoidal tone. Most other investigators do not indicate how they have switched the tones on and off, and they may have made a similar error.

6. Conclusion

The hearing thresholds were determined in the pressure field at frequencies from 4 Hz to 125 Hz. Below 25 Hz values were found that are in the lower middle of the range reported by others.

The hearing thresholds in the free field were already reported at frequencies from 25 Hz to 1 kHz. Almost identical values were found at the overlapping frequencies from 25-125 Hz. Accordingly, it was concluded that there is no difference between the hearing thresholds in the free field and in the pressure field, and the values found can be regarded as very reliable.

TABLE I
Hearing Thresholds in Pressure Field

Frequency (Hz)	Mean value (dB)	Standard deviation (dB)	Number of subjects
4	107.1	2.4	10
8	99.8	5.0	12
10	97.2	6.3	12
12.5	91.9	6.4	12
16	87.5	5.9	12
20	78.7	5.1	12
25	69.5	6.1	12
31.5	61.1	6.3	12
40	51.7	4.0	12
50	45.9	4.4	12
63	35.9	5.2	12
80	33.3	4.9	12
100	27.4	4.1	12
125	24.8	4.0	12

References

1. G. von Békésy, *Experiments in Hearing*, Mc-Graw Hill, 257, (1960).
2. N.S. Yeowart, M.E. Bryan and W. Tempest, "The Monaural MAP Threshold of Hearing at Frequencies from 1.5 to 100 c/s", *Journal of Sound and Vibration*, Vol.6, No.3, 335-342 (1967).

LOW FREQUENCY HEARING THRESHOLDS

3. N.S. Yeowart and M.J. Evans, "Threshold of Audibility for Very Low-Frequency Pure Tones", *Journal of the Acoustical Society of America*, Vol.55, No.4, 814-818 (1974).
4. L.S. Whittle and D.W. Robinson, "The Audibility of Low-Frequency Sounds", *Journal of Sound and Vibration*, Vol.21, No.4, 431-448 (1972).
5. Y. Tokita, S. Nakamura and A. Oda, "On the Hearing Threshold for Low Frequencies", *Proceedings of the Spring Meeting. (The Acoustical Society of Japan)*, 133-134 (1981).
6. S. Yamada, Y. Ando and T. Nishitami, "Influence on Human Body by Low Frequency Noise - 5th Report", *Proceedings of the Spring Meeting. (The Acoustical Society of Japan)*, 129-130 (1981).
7. H. Møller, "Construction of a Test Chamber for Human Infrasound Exposure", *Journal of Low Frequency Noise and Vibration*, Vol.1, No.3 (1982).
8. T. Watanabe, H. Møller, "Hearing Thresholds and Equal Loudness Contours in Free Field at Frequencies below 1 kHz", *Journal of Low Frequency Noise and Vibration*, Vol 9, No.4 (1990) (to be published).
9. *ISO Recommendation R226*, "Normal equal-loudness contours for pure tones and normal threshold of hearing under free field conditions", (1961).