



**AALBORG UNIVERSITY**  
DENMARK

**Aalborg Universitet**

## **Plug-and-play control and consensus algorithms for current sharing in DC microgrids**

Tucci, Michele; Meng, Lexuan; Guerrero, Josep M.; Ferrari-Trecate, Giancarlo

*Published in:*  
IFAC-PapersOnLine

*DOI (link to publication from Publisher):*  
[10.1016/j.ifacol.2017.08.1918](https://doi.org/10.1016/j.ifacol.2017.08.1918)

*Publication date:*  
2017

*Document Version*  
Publisher's PDF, also known as Version of record

[Link to publication from Aalborg University](#)

*Citation for published version (APA):*  
Tucci, M., Meng, L., Guerrero, J. M., & Ferrari-Trecate, G. (2017). Plug-and-play control and consensus algorithms for current sharing in DC microgrids. *IFAC-PapersOnLine*, 50(1), 12440-12445.  
<https://doi.org/10.1016/j.ifacol.2017.08.1918>

### **General rights**

Copyright and moral rights for the publications made accessible in the public portal are retained by the authors and/or other copyright owners and it is a condition of accessing publications that users recognise and abide by the legal requirements associated with these rights.

- Users may download and print one copy of any publication from the public portal for the purpose of private study or research.
- You may not further distribute the material or use it for any profit-making activity or commercial gain
- You may freely distribute the URL identifying the publication in the public portal -

### **Take down policy**

If you believe that this document breaches copyright please contact us at [vbn@aub.aau.dk](mailto:vbn@aub.aau.dk) providing details, and we will remove access to the work immediately and investigate your claim.

# Plug-and-play control and consensus algorithms for current sharing in DC microgrids

Michele Tucci\* Lexuan Meng\*\* Josep M. Guerrero\*\*  
Giancarlo Ferrari-Trecate\*\*\*

\* *Dipartimento di Ingegneria Industriale e dell'Informazione, Università degli Studi di Pavia (e-mail: michele.tucci02@universitadipavia.it).*

\*\* *Institute of Energy Technology, Aalborg University, 9220 Aalborg, Denmark (e-mails: lme@et.aau.dk, joz@et.aau.dk)*

\*\*\* *Automatic Control Laboratory, École Polytechnique Fédérale de Lausanne (EPFL), Switzerland (e-mail: giancarlo.ferraritrecate@epfl.ch)*

**Abstract:** In this paper, we propose a secondary consensus-based control layer for current sharing and voltage balancing in DC microGrids (mGs). Differently from existing approaches based on droop control, we assume decentralized Plug-and-Play (PnP) regulators at the primary level, as they provide voltage stabilization and their design complexity is independent of the mG size. We analyze the behavior of the closed-loop mG by approximating local primary control loops with unitary gains. This analysis can be extended to the more complex case where primary control loops are abstracted into first-order transfer functions (Tucci et al., 2016a). Besides showing stability, current sharing, and voltage balancing in the asymptotic régime, we describe how to design secondary controllers in a PnP fashion when Distributed Generation Units (DGUs) are added or removed. Theoretical results are complemented by simulations using a 5-DGUs mG implemented in Simulink/PLECS.

© 2017, IFAC (International Federation of Automatic Control) Hosting by Elsevier Ltd. All rights reserved.

**Keywords:** Distributed control, voltage control, asymptotic stability, electrical networks, renewable energy systems.

## 1. INTRODUCTION

Power generation and distribution are rapidly changing due to the increasing diffusion of renewable energy sources, advances in energy storage, and active participation of consumers to the energy market (Ipakchi and Albuyeh, 2009). This shift of paradigm has motivated the development of microGrids (mGs), commonly recognized as small-scale power systems integrating Distributed Generation Units (DGUs), storage devices and loads. Since AC power generation is the standard for commercial, residential and industrial utilization, several studies focused on AC mGs (Guerrero et al., 2013; Rivero et al., 2015; Bolognani and Zampieri, 2013). However, nowadays, DC energy systems are gaining interest (Dragicevic et al., 2016) because of the increasing number of DC loads, the availability of efficient converters, and the need of interfacing DC energy sources and batteries with minimal power losses. The basic issues in control of DC mGs are voltage stabilization (Dragicevic et al., 2016; Tucci et al., 2016b) and current sharing, the latter meaning that DGUs must compensate constant load currents proportionally to given parameters (for example, the converter ratings) and independently of the mG topology and line impedances. Current sharing is crucial for preserving the safety of the system, as unregulated currents may overload generators and eventually lead fail-

ures or system blackout (Han et al., 2016). An additional desirable goal is voltage balancing, i.e. to keep the average output voltage of DGUs close to a prescribed level. Indeed, load devices are designed to be supplied by a nominal reference voltage: it is therefore important to ensure that the voltages at the load buses are spread around this value. To realize these objectives, hierarchical control structures have been proposed. In the primary layer, current sharing regulation is usually implemented through decentralized droop controllers. However, droop regulators alone induce steady-state voltage drifts and might fail to guarantee voltage stability. For solving this problem, in (Zhao and Dörfler, 2015; Meng et al., 2016; Andreasson et al., 2014) it has been proposed to complement them with a secondary distributed control layer based on consensus algorithms. The main drawback of these approaches is that voltage stability critically depends on the communication network, which can be compromised by faults, delays or cyber attacks. Moreover, in terms of control design, the tuning of stabilizing droop and consensus controllers is often done in a centralized fashion, i.e. exploiting knowledge about all DGUs and lines (Dragicevic et al., 2016). Synthesis algorithms of this kind become prohibitive for large mGs or networks with flexible structure. This motivated the development of *scalable* design procedures for local primary controllers as in (Tucci et al., 2016b) and (Zhao and Dörfler,

2015). In (Tucci et al., 2016b), the aim is to stabilize the voltage only via primary decentralized controllers. These regulators, termed Plug-and-Play (PnP), have the following features: (i) the computation of the local controller for a DGU can be cast into a local optimization problem, (ii) each optimization problem exploits information about the DGU only and, at most, the power lines connected to it, and (iii) when a DGU is plugged-in, only neighboring DGUs must update their local controllers.

The goal of this paper is to enhance PnP controllers with secondary regulators in order to achieve current sharing and voltage balancing. Similarly to (Zhao and Dörfler, 2015), we exploit consensus filters requiring DGUs to communicate in real-time over a network with arbitrary, yet connected, topology. There are, however, several differences between the approach in (Zhao and Dörfler, 2015) and the present paper. First, as recalled above, in (Zhao and Dörfler, 2015) the networked secondary layer is necessary for voltage stability, as primary loops induce steady-state voltage drifts. In our case, secondary controllers can be turned off without compromising voltage stability. Second, in (Zhao and Dörfler, 2015) DGUs under the action of primary controllers are abstracted into ideal voltage regulators. We also use this simplification, but only for tutorial reasons. In fact, in (Tucci et al., 2016a) we show that our proof can be extended to the more realistic case where primary control loops are abstracted into first-order transfer functions.

At the mathematical level, in order to prove current sharing and voltage balancing, we characterize the eigenstructure of the product of three matrices ( $\mathbb{LDM}$ ), where  $\mathbb{L}$  and  $\mathbb{M}$  are the graph Laplacians associated to the electrical and the communication graphs, respectively, and  $D$  is a diagonal positive definite matrix defining the desired ratios between balanced currents. While several studies focused on the properties of the product of stochastic matrices (see e.g. (Jadbabaie et al., 2003)), which are central in discrete-time consensus, to our knowledge products of Laplacians received much less attention.

The paper is organized as follows. Section 2 summarizes the electrical model of DGUs and PnP controllers. The secondary control layer is developed and analyzed in Section 3 and 4. Section 5 demonstrates current sharing and voltage balancing through simulations in Simulink/PLECS (Allmeling and Hammer, 2013), where non-idealities of real converters and lines have been taken into account. Due to space limitations, we omit the proofs and refer to (Tucci et al., 2016a) for details.

**Notation and basic definitions.** The cardinality of the finite set  $S$  will be denoted with  $|S|$ . A weighted graph is a directed graph (*digraph*)  $\mathcal{G} = (\mathcal{V}, \mathcal{E}, W)$  defined by the set of nodes  $\mathcal{V} = \{1, \dots, n\}$ , the set of edges  $\mathcal{E} \subseteq \mathcal{V} \times \mathcal{V}$  and the diagonal matrix  $W \in \mathbb{R}^{|\mathcal{E}| \times |\mathcal{E}|}$  collecting on its diagonal the weights  $w_i$  associated to edges  $e_i \in \mathcal{E}$  (i.e.  $W_{ii} = w_i$ ). The set of neighbors of node  $i \in \mathcal{V}$  is  $\mathcal{N}_i = \{j : (i, j) \in \mathcal{E} \text{ or } (j, i) \in \mathcal{E}\}$ . A digraph  $\mathcal{G}$  is *weakly connected* if its undirected version is connected (Bullo, 2016).  $Q(\mathcal{G}) \in \mathbb{R}^{|\mathcal{V}| \times |\mathcal{E}|}$  is the incidence matrix of  $\mathcal{G}$  (Grone et al., 1990). The Laplacian matrix of  $\mathcal{G}$  is  $\mathcal{L}(\mathcal{G}) = Q(\mathcal{G})WQ(\mathcal{G})^T$ , and it is independent of the orientation of edges. The average of a vector  $v \in \mathbb{R}^n$  is  $\langle v \rangle = \frac{1}{n} \sum_{i=1}^n v_i$ . We denote with  $H^1$  the subspace composed by all vectors with zero average (Bensoussan

and Menaldi, 2005; Ferrari-Trecate et al., 2006) i.e.  $H^1 = \{v \in \mathbb{R}^n : \langle v \rangle = 0\}$ . The space orthogonal to  $H^1$  is  $H^\perp$ . It holds  $H^\perp = \{\alpha \mathbf{1}_n, \alpha \in \mathbb{R}\}$  and  $\dim(H^\perp) = 1$ . Moreover, the decomposition  $\mathbb{R}^n = H^1 \oplus H^\perp$  is direct, i.e. each vector  $v \in \mathbb{R}^n$  can always be written in a unique way as

$$v = \hat{v} + \bar{v} \quad \text{with } \hat{v} \in H^1 \text{ and } \bar{v} \in H^\perp. \quad (1)$$

Consider the matrix  $A \in \mathbb{R}^{n \times n}$ . With the notation  $A(H^1|H^1)$  we indicate the linear map  $A : H^1 \rightarrow H^1$  (i.e. the restriction of the map  $A : \mathbb{R}^n \rightarrow \mathbb{R}^n$  to the subspace  $H^1$ ). For a subspace  $\mathcal{V} \subset \mathbb{R}^n$ , we denote with  $P_{\mathcal{V}}(v)$  the projection of  $v \in \mathbb{R}^n$  on  $\mathcal{V}$ .

Laplacian matrices have key properties summarized in the next Proposition (Godsil and Royle, 2001; Bensoussan and Menaldi, 2005).

*Proposition 1.* For a weakly connected graph  $\mathcal{G}$  with weights  $w_i > 0$ ,  $A = \mathcal{L}(\mathcal{G}) \in \mathbb{R}^{n \times n}$  has the following properties:

- (i) it has non positive off-diagonal elements;
- (ii)  $\lambda_1(A) \geq \dots \geq \lambda_{n-1}(A) \geq 0 = \lambda_n$ ;
- (iii)  $\text{Ker}(A) = H^\perp$  and  $\text{Range}(A) = H^1$ ;
- (iv)  $A(H^1|H^1)$  is invertible.

## 2. PLUG-AND-PLAY PRIMARY VOLTAGE CONTROL

### 2.1 DGU electrical model

As in (Tucci et al., 2016b), we consider a DC mG composed of  $N$  DGUs, whose electrical scheme is shown in Figure 1. In each DGU, the generic renewable resource is modeled as a battery, and a Buck converter is used to supply a local load connected to the Point of Common Coupling (PCC) through an  $RLC$  filter. Furthermore, we assume that loads  $I_{Li}$  are unknown and treated as current disturbances (Tucci et al., 2016b). The controlled variable is the voltage at each PCC. From Figure 1, by applying Kirchoff's voltage and current laws and exploiting Quasi Stationary Line (QSL) approximation of power lines (Tucci et al., 2016b), we obtain the following model of DGU  $i$ <sup>1</sup>

$$\text{DGU } i : \begin{cases} \frac{dV_i}{dt} = \frac{1}{C_{ti}} I_{ti} + \sum_{j \in \mathcal{N}_i} \left( \frac{V_j}{C_{ti} R_{ij}} - \frac{V_i}{C_{ti} R_{ij}} \right) - \frac{1}{C_{ti}} I_{Li} \\ \frac{dI_{ti}}{dt} = -\frac{1}{L_{ti}} V_i - \frac{R_{ti}}{L_{ti}} I_{ti} + \frac{1}{L_{ti}} V_{ti} \end{cases}$$

where inputs  $(V_{ti}, I_{Li})$  and  $V_j \in \mathcal{N}_i$ , states  $(V_i, I_{ti})$ , and electrical parameters  $R_{ti}, C_{ti}, L_{ti}$  and  $R_{ij}$  are shown in Figure 1. In particular,  $V_j$  is the voltage at the PCC of each neighboring DGU  $j \in \mathcal{N}_i$ .

### 2.2 Plug-and-play design

In this Section, we briefly summarize the PnP scalable approach in (Tucci et al., 2016b) for designing primary decentralized controllers guaranteeing voltage stability in DC mGs. This will allow us to justify the approximation of primary controllers used in Section 4.1.

The local regulator of DGU  $i$  exploits measurements of  $V_i$  and  $I_{ti}$  to compute the command  $V_{ti}$  of the  $i$ -th Buck converter and make  $V_i$  track a reference signal  $V_{ref,i}$  (see

<sup>1</sup> For the detailed model derivation, we defer the reader to (Tucci et al., 2016b).

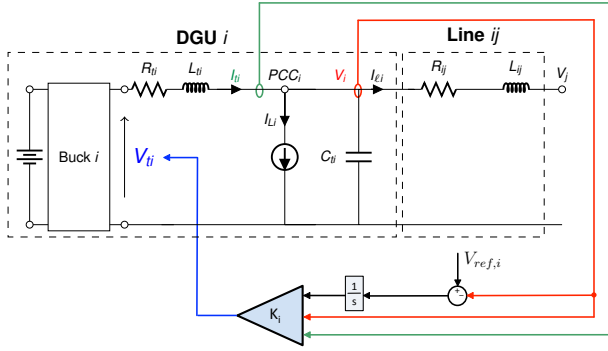

Fig. 1. Electrical scheme of DGU  $i$  and local PnP voltage controller.

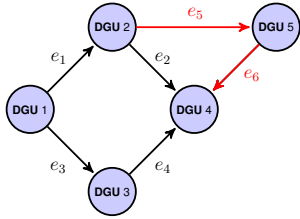

Fig. 2. Graph representation of an mG composed of 4 DGUs (in black) and plug-in of DGU 5 (in red).

the scheme in Figure 1). Each controller is composed of a vector matrix gain  $K_i$  and an integral action is present for offset-free voltage tracking. The decentralized design of these vector gains is the core of PnP methodology. In particular, as shown in (Tucci et al., 2016b), (i) the design of  $K_i$  requires only knowledge of the dynamics of DGU  $i$  and the parameters of power lines connecting it to its neighbors, and (ii)  $K_i$  is automatically computed solving a Linear Matrix Inequality (LMI) problem.

For modeling the interaction of multiple DGUs, we represent the mG with a directed graph  $\mathcal{G}_{el} = (\mathcal{V}_{el}, \mathcal{E}_{el}, W)$  (see e.g. Figure 2), where (i) each node is a DGU with local PnP controller and local current load, (ii) edges  $(i, j)$  are power lines whose orientation define a reference direction for positive currents, (iii) weights are line conductances<sup>2</sup>  $\frac{1}{R_{i,j}}$ , and (iv) we set  $N = |\mathcal{V}_{el}|$  and  $M = |\mathcal{E}_{el}|$ .

Next, we describe how to handle plugging -in/-out of DGUs while preserving the stability of the mG. Whenever a DGU (say DGU  $i$ ) wants to join the network (e.g. DGU 5 in Figure 2), it sends a plug-in request to its future neighbors, i.e. DGUs  $j \in \mathcal{N}_i$  (e.g. DGUs 2 and 4 in Figure 2). Then, each DGU in the set  $\{i\} \cup \mathcal{N}_i$  solves the LMI problem (25) in (Tucci et al., 2016b) that, if feasible, gives a vector gain  $K_i$  guaranteeing voltage stability in the whole mG after the addition of DGU  $i$ . Otherwise, if one of the LMIs is infeasible, the plug-in of DGU  $i$  is denied and no update of matrices  $K_j$ ,  $j \in \mathcal{N}_i$  is performed. We highlight that, upon the plugging-in of DGU  $i$ , the update of gains  $K_j$ ,  $j \in \mathcal{N}_i$  is necessary as DGUs  $j \in \mathcal{N}_i$  will be affected by new lines  $ij$ . Unplugging of a DGU (say DGU  $m$ ) follows a similar procedure. Notably, as line  $mk$  will be disconnected, each DGU  $k$ ,  $k \in \mathcal{N}_m$  must successfully redesign its local controller before allowing the disconnection of DGU  $m$ .

<sup>2</sup> Line inductances  $L_{i,j}$  are neglected as we assume QSL approximations (Tucci et al., 2016b).

### 3. SECONDARY CONTROL BASED ON CONSENSUS ALGORITHMS

PnP local controllers have the goal of turning DGUs into controlled voltage generators, i.e. to approximate, as well as possible, the identity  $V_i = V_{ref,i}$ . As such, they do not ensure current sharing and voltage balancing, defined in the sequel.

*Definition 1.* For constant load currents  $I_{L_i}$ ,  $i = 1, \dots, N$ , *current sharing* is achieved if, at steady state, the overall load current is proportionally shared among DGUs, i.e. if

$$\frac{I_{t_i}^s}{I_{t_i}^s} = \frac{I_{t_j}^s}{I_{t_j}^s} \quad \text{for all } i, j \in \mathcal{V}_{el}, \quad (2)$$

where  $I_{t_i}^s > 0$  are scaling factors.

A practical way to make DGUs share their load currents proportionally, for instance, to their generation capacity, is to measure the output currents in per-unit (p.u.), thus setting each scaling factor  $I_{t_i}^s$  in (2) equal to the corresponding DGU rated current. On the other hand, if  $I_{t_i}^s = \bar{I}_{t_i}$ ,  $i = 1, \dots, N$  (i.e. if the scaling factor is the same for all the DGUs), the current sharing condition becomes

$$I_{t_i} = \langle \mathbf{I}_L \rangle \quad i = 1, \dots, N, \quad (3)$$

where  $\mathbf{I}_L = [I_{L1}, I_{L2}, \dots, I_{LN}]^T$  is the vector of the local load currents.

*Assumption 1.* Voltage references are identical for all DGUs, i.e.  $V_{ref,i} = V_{ref}$ ,  $\forall i \in \mathcal{V}_{el}$ .

*Definition 2.* Under Assumption 1, *voltage balancing* is achieved if

$$\langle \mathbf{V} \rangle = V_{ref}. \quad (4)$$

where vector  $\mathbf{V} = [V_1, V_2, \dots, V_N]^T$  collects the PCC voltages.

In order to guarantee current sharing and voltage balancing, we use a consensus-based secondary control layer. Consensus filters are commonly employed for achieving global information sharing or coordination through distributed computations (Bullo, 2016). In our case, as shown in Figure 3, we adopt the following consensus scheme for adjusting the references of each PnP voltage regulator

$$\Delta \dot{V}_i(t) = k_I \sum_{j=1, j \neq i}^N a_{ij} \left( \frac{I_{t_i}(t)}{I_{t_i}^s} - \frac{I_{t_j}(t)}{I_{t_j}^s} \right), \quad (5)$$

where  $a_{ij} > 0$  if DGUs  $i$  and  $j$  are connected by a communication link ( $a_{ij} = 0$ , otherwise) and the coefficient  $k_I > 0$  is common to all DGUs. The use of consensus protocols has been thoroughly studied for networks of agents with simple dynamics, e.g. simple integrators (Bullo, 2016), with the goal of proving convergence of individual states to a common value. In our case, however, (5) is interfaced with the mG dynamics and convergence of currents  $I_{t_i}$  to the same value does not trivially follow from standard consensus theory. This property will be analyzed in Section 4.

In the sequel, we assume bidirectional communication, i.e.  $a_{ij} = a_{ji}$ . The corresponding communication digraph is  $\mathcal{G}_c = (\mathcal{V}_{el}, \mathcal{E}_c, W_c)$  where  $(i, j) \in \mathcal{E}_c \iff a_{ij} > 0$  and  $W_c = \text{diag}\{a_{ij}\}$ . Note that the topology of  $\mathcal{G}_c$  and  $\mathcal{G}_{el}$  can be completely different. From now on, we will make the following standing assumption.

*Assumption 2.* The graphs  $\mathcal{G}_{el}$  and  $\mathcal{G}_c$  are weakly connected.

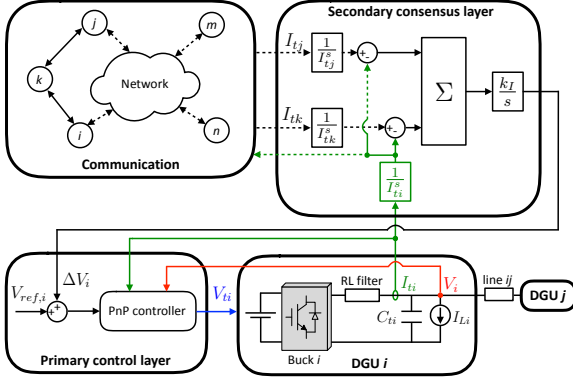

Fig. 3. Complete hierarchical control scheme of DGU  $i$ .

From a system point of view, the collective dynamics of the group of DGUs following (5) can be expressed as

$$\dot{\Delta \mathbf{V}} = - \underbrace{k_I \mathbf{L}}_{\mathbf{L}} \mathbf{D} \mathbf{I}_t, \quad (6)$$

where  $\Delta \mathbf{V} = [\Delta V_1, \dots, \Delta V_N]^T = \mathbf{V} - \mathbf{V}_{\text{ref}}$ ,  $\mathbf{V}_{\text{ref}} = [V_{\text{ref},1}, V_{\text{ref},2}, \dots, V_{\text{ref},N}]^T$ ,  $\mathbf{I}_t = [I_{t1}, I_{t2}, \dots, I_{tN}]^T$ ,  $\mathbf{D} = \text{diag} \left( \frac{1}{I_{t1}^s}, \dots, \frac{1}{I_{tN}^s} \right)$  and  $\mathbf{L} = \mathcal{L}(\mathcal{G}_c)$ . Note that  $\mathbf{L}$  is the Laplacian matrix of  $\mathcal{G}_c$  with  $W_c$  replaced by  $k_I W_c$ .

#### 4. MODELING AND ANALYSIS OF THE COMPLETE SYSTEM

The hierarchical control scheme of a DGU equipped with primary and secondary regulators is depicted in Figure 3. For studying the behavior of the closed-loop mG, we approximate PnP-controlled DGUs by unit gains and show that current sharing and voltage balancing are achieved in a stable way. For the more complex analysis where primary control loops are abstracted into first-order transfer functions, we defer the reader to (Tucci et al., 2016a).

##### 4.1 Unit-gain approximation of PnP-controlled DGUs

By approximating primary PnP loops with ideal unit gains, we have the relations  $V_i = V_{\text{ref},i} + \Delta V_i$ ,  $\forall i \in \mathcal{V}_{el}$ . Figure 4 shows the resulting control scheme, used for deriving the dynamics of the overall mG as a function of the inputs  $\mathbf{I}_L$  and  $\mathbf{V}_{\text{ref}}$ . Starting from the left-hand side of Figure 4, we have, in order, (6) and

$$\mathbf{V} = \Delta \mathbf{V} + \mathbf{V}_{\text{ref}}. \quad (7)$$

Then, from basic circuit theory, we derive the relation between the vector of voltages  $\mathbf{V}$  and the vector of line currents  $\mathbf{I}_\ell = [I_{\ell 1}, \dots, I_{\ell M}]^T$  as

$$\mathbf{I}_\ell = -\mathbf{W} \mathbf{B}^T \mathbf{V}, \quad (8)$$

where  $\mathbf{W}$  is the weight matrix of  $\mathcal{G}_{el}$  and  $\mathbf{B} = \mathbf{Q}(\mathcal{G}_{el})$  is the incidence matrix of the mG. Next, we get

$$\mathbf{I}_t = \mathbf{I}_L - \mathbf{B} \mathbf{I}_\ell \quad (9)$$

and, merging equations (6)-(9), we finally obtain

$$\begin{aligned} \Sigma : \dot{\Delta \mathbf{V}} &= -\mathbf{L} \mathbf{D} \underbrace{\mathbf{B} \mathbf{W} \mathbf{B}^T}_{\mathbf{M}} \Delta \mathbf{V} - \mathbf{L} \mathbf{D} \mathbf{I}_L - \mathbf{L} \mathbf{D} \underbrace{\mathbf{B} \mathbf{W} \mathbf{B}^T}_{\mathbf{M}} \mathbf{V}_{\text{ref}} \\ &= -\mathbf{Q} \Delta \mathbf{V} - \mathbf{L} \mathbf{D} \mathbf{I}_L - \mathbf{Q} \mathbf{V}_{\text{ref}} \end{aligned} \quad (10)$$

where  $\mathbf{M} = \mathcal{L}(\mathcal{G}_{el}) = \mathbf{B} \mathbf{W} \mathbf{B}^T$  is the Laplacian matrix of the electrical network and  $\mathbf{Q} = \mathbf{L} \mathbf{D} \mathbf{M}$ . Notice that  $\mathbf{Q}$  is

obtained pre- and post- multiplying a diagonal matrix by a Laplacian ( $\mathbf{L}$  and  $\mathbf{M}$ , respectively). It follows that  $\mathbf{Q}$  is not a Laplacian matrix itself because it might fail to be symmetric and have positive off-diagonal entries, even if weights of  $\mathcal{G}_{el}$  and  $\mathcal{G}_c$  are positive. Nevertheless, in the next Proposition, we show that  $\mathbf{Q}$  preserves some key features of Laplacian matrices.

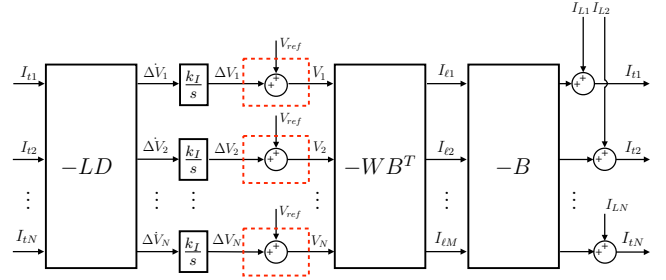

Fig. 4. Hierarchical control scheme with unit-gain approximation of PnP loops (dashed boxes).

*Proposition 2.* The matrix  $\mathbf{Q} = \mathbf{L} \mathbf{D} \mathbf{M}$  has the following properties:

- $\text{Ker}(\mathbf{Q}) = H^1_{\perp}$ ;
- $\text{Range}(\mathbf{Q}) = H^1$ ;
- the linear transformation  $\mathbf{Q}(H^1|H^1)$  is invertible;
- $\mathbf{Q}$  has real nonnegative eigenvalues;
- the zero eigenvalue of  $\mathbf{Q}$  has algebraic multiplicity equal to one.

*Analysis of equilibria* In order to evaluate the steady-state behavior of the electrical signals appearing in Figure 4, we study the equilibria of system (10). Hence, for given constant inputs  $(\mathbf{I}_L^*, \mathbf{V}_{\text{ref}}^*)$ , we characterize the solutions  $\Delta \mathbf{V}^*$  of equation

$$\mathbf{Q} \Delta \mathbf{V}^* = -\mathbf{L} \mathbf{D} \mathbf{I}_L^* - \mathbf{Q} \mathbf{V}_{\text{ref}}^* \quad (11)$$

and characterize them through the following Proposition.

*Proposition 3.* For equation (11),

- there is only one solution  $\widetilde{\Delta \mathbf{V}}^* \in H^1$ ;
- all solutions  $\Delta \mathbf{V}^* \in \mathbb{R}^N$  can be written as

$$\Delta \mathbf{V}^* = \widetilde{\Delta \mathbf{V}}^* + \alpha \mathbf{1}_N \quad \alpha \in \mathbb{R}. \quad (12)$$

Next, we establish relevant properties of the equilibria of (10).

*Proposition 4.* Consider system (10) with constant inputs  $(\mathbf{I}_L^*, \mathbf{V}_{\text{ref}}^*)$ . Then, current sharing is achieved at steady state. Moreover, if  $\mathbf{V}_{\text{ref}}^* = V_{\text{ref}} \mathbf{1}_N$  (i.e. Assumption 1 holds) and  $\alpha$  in (12) is equal to zero, then the equilibrium  $\mathbf{V}^*$  verifies the voltage balancing condition (4).

In the sequel, we show the convergence of  $\Delta \mathbf{V}$  in (10) to an equilibrium ensuring both current sharing and voltage balancing for constant  $\mathbf{I}_L^*$  and  $\mathbf{V}_{\text{ref}}^* = V_{\text{ref}} \mathbf{1}_N$ .

*Stability analysis* We first analyze the dynamics of projections  $P_{H^1_{\perp}}(\Delta \mathbf{V}) = \widetilde{\Delta \mathbf{V}}$  and  $P_{H^1}(\Delta \mathbf{V}) = \widehat{\Delta \mathbf{V}}$ .

*Proposition 5.* If  $\Delta \mathbf{V}$  is given by system  $\Sigma$  in (10) for  $\Delta \mathbf{V}(0) = \Delta \mathbf{V}_0$ , then  $\Delta \mathbf{V} = \widetilde{\Delta \mathbf{V}} + \widehat{\Delta \mathbf{V}}$ , where  $\widetilde{\Delta \mathbf{V}} \in H^1_{\perp}$  and  $\widehat{\Delta \mathbf{V}} \in H^1$  fulfill

$$\bar{\Sigma} : \begin{cases} \dot{\Delta \mathbf{V}} = \mathbf{0}_N \\ \Delta \mathbf{V}(0) = \langle \Delta \mathbf{V}_0 \rangle \mathbf{1}_N \end{cases} \quad (13)$$

and

$$\hat{\Sigma} : \begin{cases} \dot{\Delta \mathbf{V}} = -\mathbb{Q} \Delta \mathbf{V} - \mathbb{L} D \mathbf{I}_L - \mathbb{Q} \mathbf{V}_{\text{ref}} \\ \Delta \mathbf{V}(0) = \Delta \mathbf{V}_0 - \overline{\Delta \mathbf{V}}_0. \end{cases} \quad (14)$$

*Remark 1.* The splitting of  $\Sigma$  into systems  $\bar{\Sigma}$  and  $\hat{\Sigma}$  implies that, if  $\Delta \mathbf{V}_0$  has zero average, then  $\Delta \mathbf{V}(t)$  has the same property,  $\forall t \geq 0$  and irrespectively of inputs  $(\mathbf{I}_L, \mathbf{V}_{\text{ref}})$ . This behavior can be realized by suitable initialization of the integrators appearing in Figure 4.

According to system  $\bar{\Sigma}$ , the value of  $P_{H^1}(\Delta \mathbf{V}) = \overline{\Delta \mathbf{V}}$  remains constant over time and equal to  $\overline{\Delta \mathbf{V}}_0$ . Hence, in order to characterize the stability of equilibria (12), it is sufficient to study the dynamics (14). In an equivalent way, one can consider system (10) and the following definition of stability on a subspace.

*Definition 3.* Let  $\mathcal{V}$  be a subspace of  $\mathbb{R}^n$ . The origin of  $\dot{x} = Ax$ ,  $x(t) \in \mathbb{R}^n$  is Globally Exponentially Stable (GES) on  $\mathcal{V}$  if  $\exists \kappa, \eta > 0 : \|P_{\mathcal{V}}x(t)\| \leq \kappa e^{-\eta t} \|P_{\mathcal{V}}x(0)\|$ . The parameter  $\eta$  is termed *rate of convergence*.

Note that  $\Sigma$  is a linear system and, for stability analysis, we can neglect inputs, hence obtaining

$$\begin{cases} \dot{\Delta \mathbf{V}} = -\mathbb{Q} \Delta \mathbf{V} \\ \Delta \mathbf{V}(0) = \Delta \mathbf{V}_0. \end{cases} \quad (15)$$

*Theorem 1.* The origin of (15) is GES on  $H^1$ . Moreover, the rate of convergence is the smallest strictly positive eigenvalue of  $\mathbb{Q}$ .

The above results reveal that, given an initial condition  $\Delta \mathbf{V}(0) = \Delta \mathbf{V}_0$  for system (10) and constant inputs  $\mathbf{I}_L^*$  and  $\mathbf{V}_{\text{ref}}^* = V_{\text{ref}} \mathbf{1}_N$ , the state  $\Delta \mathbf{V}$  converges to the equilibrium (12) with  $\alpha = \langle \Delta \mathbf{V}_0 \rangle$ .

Summarizing the main results of this Section, we have that the consensus scheme described by (5), Assumption 1 and

$$\langle \Delta \mathbf{V}_0 \rangle = 0 \quad (16)$$

guarantee the asymptotic achievement of current sharing and voltage balancing in a GES fashion.

#### 4.2 PnP design of secondary control

We now describe the procedure for designing secondary controllers in a PnP fashion. We will show that, as for the PnP design of primary regulators, when a DGU is added or removed, the secondary control layer can be updated only locally for preserving current sharing and voltage balancing. When a DGU (say DGU  $i$ ) sends a plug-in request at a time  $\bar{t}$ , it choses a set  $\mathcal{N}_i^c$  of communication neighbors and fixes parameters  $a_{ij} > 0, \forall j \in \mathcal{N}_i^c$ , in order to design the local consensus filter (5). At the same time, each DGU  $j, j \in \mathcal{N}_i^c$ , updates its consensus filter by setting  $a_{ji} = a_{ij}$  in (5). Theorem 1 ensures that the disagreement dynamics of the mG states is GES, independently of  $\mathcal{N}_i^c$ . Let Assumption 1 hold for all the interconnected DGUs in the mG before  $\bar{t}$  and let us denote the common reference voltage by  $V_{\text{ref}}$ . If DGU  $i$  sets  $V_{\text{ref},i} = V_{\text{ref}}$  and if we choose  $\Delta V_i(\bar{t}) = 0$  (thus having  $\langle [\Delta \mathbf{V}'(\bar{t})^T \Delta V_i(\bar{t})]^T \rangle = 0$ , where  $\Delta \mathbf{V}'(\bar{t})$  is the vector  $\Delta \mathbf{V}$  prior the plugging-in

of DGU  $i$ ), both current sharing and voltage balancing are preserved in the asymptotic régime (see Proposition 4). The procedure for handling unplugging operations while ensuring current sharing and voltage balancing is described in (Tucci et al., 2016a).

## 5. SIMULATION RESULTS

In this Section, we demonstrate the capability of the proposed control scheme to guarantee current sharing and voltage balancing when DGUs are added or load changes occur. Simulations have been performed in Simulink/PLECS. We consider an mG composed of 5 DGUs, arranged as in Figure 5, with non-identical electrical parameters and power lines. Notice that some DGUs have more than one neighbor, hence the impact of couplings on their dynamics will be larger. Moreover, we choose  $I_{ti}^s = \bar{I}_t$ ,  $i = 1, \dots, 5$  (thus aiming to achieve the asymptotic current sharing condition (3)), and the voltage reference in Assumption 1 is  $V_{\text{ref}} = 48$  V. All the electrical and control parameters are collected in Appendix C of (Tucci et al., 2016a). Simulations have been performed assuming all-to-all communication among DGUs. In the following, we describe Figure 6, which illustrates the evolution of the main electrical quantities (i.e. DGU measured output currents, PCC voltages and average PCCs voltage) during the consecutive simulation stages shown in Figure 5.

At time  $t_0 = 0$ , all the DGUs are assumed to be isolated and only the primary PnP voltage regulators are active. Therefore, as shown in stage 1, (i) each DGU supplies its local load while keeping the corresponding PCC voltage at 48 V, and (ii) the DGU output currents are different. We further highlight that primary controllers have been designed assuming that all the switches in Figure 5 connecting DGUs 1-4 are closed. From (Tucci et al., 2016b), however, they also stabilize the mG when all switches are open.

At time  $t_1 = 5$  s, we connect together subsystems 1-4 and, according to the previous observation, no update of local controllers is required. At  $t_1$  we also activate the secondary control layer for DGUs 1-4, thus ensuring asymptotic convergence of the output currents to the same value (see the plot of  $I_t$ , stage 2). This is achieved by adjusting the voltages at PCC (as shown in the plot of  $V_{PCC}$ , stage 2). Furthermore, by setting  $\Delta V_i(t_1) = 0$ ,  $i = 1, \dots, 4$ , as described in Section 4.2, condition (16) is verified and asymptotic voltage balancing is guaranteed (see  $V_{av}$  during stage 2).

For evaluating the PnP capabilities of our control scheme, at  $t_2 = 16$  s, DGU 5 sends a plug-in request to DGU 4. Previous PnP controllers of DGUs 4 and 5 still fulfill the plug-in conditions in (Tucci et al., 2016b): they are therefore maintained and the plug-in of DGU 5 is performed. At the same time, the secondary controller of DGU 5 is activated, and then the DGU contributes to current sharing (see the top plot in Figure 6, stage 3). Furthermore, by setting  $\Delta V_5(t_2) = 0$ , as described in Section 4.2, we can maintain the average PCCs voltage at 48 V (see  $V_{av}$ , stage 3).

Finally, at  $t_3 = 30$  s (stage 4), we halve the load of DGU 1, thus increasing the corresponding load current  $I_{L1}$  and causing a peak in the corresponding output current. However, after few seconds, all the DGUs share again the total load current, while the averaged PCCs voltage converges to the reference value.

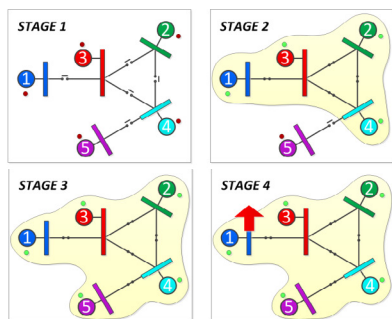

Fig. 5. Simulation stages: numbered nodes represent DGUs and black lines denote power lines. The small circle next to each DGU is green if the secondary control layer is active for the corresponding unit, red otherwise. Open switches in stages 1 and 2 denote disconnected DGUs. The arrow in stage 4 represents a step up in the load current of DGU 1.

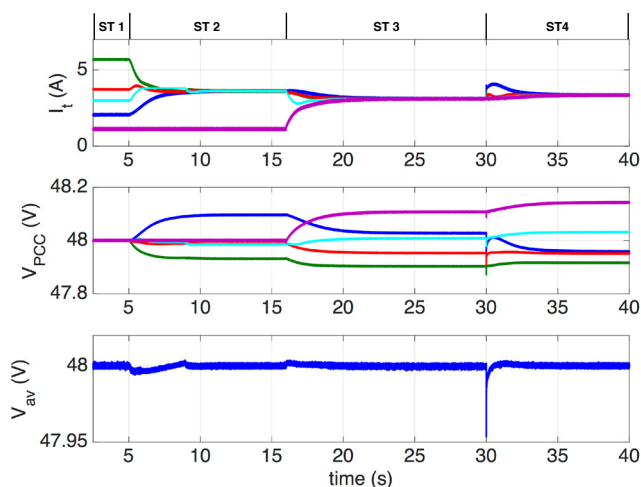

Fig. 6. Evolution of the output currents, voltages at PCCs and average PCCs voltage. Lines in the plots of  $I_t$  and  $V_{PCC}$  are color-coded as in Figure 5. Simulation stages are those in Figure 5.

## 6. CONCLUSIONS

In this paper, a secondary consensus-based control layer for current sharing and voltage balancing in DC mGs has been proposed. Moreover, we presented a method for designing secondary controllers in a PnP fashion when new DGUs are added. As regards future developments, communication delays (Bliman and Ferrari-Trecate, 2008; Meng et al., 2014), will be included in the mathematical analysis.

## REFERENCES

Allmeling, J. and Hammer, W. (2013). PLECS-User Manual.

Andreasson, M., Dimarogonas, D.V., Sandberg, H., and Johansson, K.H. (2014). Control of MTDC transmission systems under local information. In *53rd Conference on Decision and Control*, 1335–1340.

Bensoussan, A. and Menaldi, J.L. (2005). Difference equations on weighted graphs. *Journal of Convex Analysis*, 12(1), 13–44.

Bliman, P.A. and Ferrari-Trecate, G. (2008). Average consensus problems in networks of agents with delayed communications. *Automatica*, 44(8), 1985–1995.

Bolognani, S. and Zampieri, S. (2013). A distributed control strategy for reactive power compensation in smart microgrids. *IEEE Transactions on Automatic Control*, 58(11), 2818–2833.

Bullo, F. (2016). *Lectures on Network Systems*. Version 0.85. URL <http://motion.me.ucsb.edu/book-1ns>.

Dragicevic, T., Lu, X., Vasquez, J.C., and Guerrero, J.M. (2016). DC microgrids-part I: A review of control strategies and stabilization techniques. *IEEE Transactions on Power Electronics*, 31(7), 4876–4891.

Ferrari-Trecate, G., Buffa, A., and Gati, M. (2006). Analysis of coordination in multi-agent systems through partial difference equations. *IEEE Transactions on Automatic Control*, 51(6), 1058–1063.

Godsil, C. and Royle, G. (2001). Algebraic graph theory, volume 207 of Graduate Texts in Mathematics.

Grone, R., Merris, R., and Sunder, V.S. (1990). The Laplacian spectrum of a graph. *SIAM Journal on Matrix Analysis and Applications*, 11(2), 218–238.

Guerrero, J.M., Chandorkar, M., Lee, T.L., and Loh, P.C. (2013). Advanced control architectures for intelligent microgrids - part I: decentralized and hierarchical control. *IEEE Transactions on Industrial Electronics*, 60(4), 1254–1262.

Han, H., Hou, X., Yang, J., Wu, J., Su, M., and Guerrero, J.M. (2016). Review of power sharing control strategies for islanding operation of ac microgrids. *IEEE Transactions on Smart Grid*, 7(1), 200–215.

Ipakchi, A. and Albuyeh, F. (2009). Grid of the future. *Power and Energy Magazine, IEEE*, 7(2), 52–62.

Jadbabaie, A., Lin, J., and Morse, A.S. (2003). Coordination of groups of mobile autonomous agents using nearest neighbor rules. *IEEE Transactions on Automatic Control*, 48(6), 988–1001.

Meng, L., Dragicevic, T., Roldn-Prez, J., Vasquez, J.C., and Guerrero, J.M. (2016). Modeling and sensitivity study of consensus algorithm-based distributed hierarchical control for DC microgrids. *IEEE Transactions on Smart Grid*, 7(3), 1504–1515.

Meng, L., Dragicevic, T., Guerrero, J.M., and Vasquez, J.C. (2014). Dynamic consensus algorithm based distributed global efficiency optimization of a droop controlled DC microgrid. In *2014 International Energy Conference*, 1276–1283.

Rivero, S., Sarzo, F., and Ferrari-Trecate, G. (2015). Plug-and-play voltage and frequency control of islanded microgrids with meshed topology. *IEEE Transactions on Smart Grid*, 6(3), 1176–1184.

Tucci, M., Meng, L., Guerrero, J.M., and Ferrari-Trecate, G. (2016a). A consensus-based secondary control layer for stable current sharing and voltage balancing in DC microgrids. Technical report. URL <http://arxiv.org/abs/1603.03624>.

Tucci, M., Rivero, S., Vasquez, J.C., Guerrero, J.M., and Ferrari-Trecate, G. (2016b). A decentralized scalable approach to voltage control of DC islanded microgrids. *IEEE Transactions on Control Systems Technology*, 24(6), 1965–1979.

Zhao, J. and Dörfler, F. (2015). Distributed control and optimization in DC microgrids. *Automatica*, 61, 18–26.