



Aalborg Universitet

AALBORG UNIVERSITY  
DENMARK

## Advanced Kalman Filter for Current Estimation in AC Microgrids

Vafamand, Navid; Arefi, Mohammad Mehdi; Javadi, Mohammad Sadegh ; Anvari-Moghaddam, Amjad ; Catalão, João P.S.

*Published in:*

2020 IEEE International Conference on Environment and Electrical Engineering and 2020 IEEE Industrial and Commercial Power Systems Europe (EEEIC / I&CPS Europe)

*DOI (link to publication from Publisher):*

[10.1109/EEEIC/ICPSEurope49358.2020.9160612](https://doi.org/10.1109/EEEIC/ICPSEurope49358.2020.9160612)

*Publication date:*

2020

*Document Version*

Accepted author manuscript, peer reviewed version

[Link to publication from Aalborg University](#)

*Citation for published version (APA):*

Vafamand, N., Arefi, M. M., Javadi, M. S., Anvari-Moghaddam, A., & Catalão, J. P. S. (2020). Advanced Kalman Filter for Current Estimation in AC Microgrids. In *2020 IEEE International Conference on Environment and Electrical Engineering and 2020 IEEE Industrial and Commercial Power Systems Europe (EEEIC / I&CPS Europe): EEEIC 2020* (pp. 1-6). Article 9160612 IEEE Press.

<https://doi.org/10.1109/EEEIC/ICPSEurope49358.2020.9160612>

### General rights

Copyright and moral rights for the publications made accessible in the public portal are retained by the authors and/or other copyright owners and it is a condition of accessing publications that users recognise and abide by the legal requirements associated with these rights.

- Users may download and print one copy of any publication from the public portal for the purpose of private study or research.
- You may not further distribute the material or use it for any profit-making activity or commercial gain
- You may freely distribute the URL identifying the publication in the public portal -

### Take down policy

If you believe that this document breaches copyright please contact us at [vbn@aub.aau.dk](mailto:vbn@aub.aau.dk) providing details, and we will remove access to the work immediately and investigate your claim.

# Advanced Kalman Filter for Current Estimation in AC Microgrids

Navid Vafamand<sup>1</sup>, Mohammad Mehdi Arefi<sup>1</sup>, Mohammad Sadegh Javadi<sup>2</sup>, Amjad Anvari-Moghadam<sup>3</sup>  
and João P.S. Catalão<sup>2,4</sup>

<sup>1</sup> Department of Power and Control Engineering, School of Electrical and Computer Engineering, Shiraz University, Shiraz, Iran

<sup>2</sup> Institute for Systems and Computer Engineering, Technology and Science (INESC TEC), 4200-465 Porto, Portugal

<sup>3</sup> Department of Energy Technology, Aalborg University, 9220 Aalborg, Denmark

<sup>4</sup> Faculty of Engineering, University of Porto (FEUP), 4200-465 Porto, Portugal

Emails: n.vafamand@shirazu.ac.ir (N.V), arefi@shirazu.ac.ir (M.M.A), msjavadi@gmail.com (M.S.J.), aam@et.aau.dk, (A.A-M) catalao@fe.up.pt (J.P.S.C.)

**Abstract**— The stability and monitoring of AC microgrids (AC MG) are greatly influenced by gathering sufficient and precise information. Since installing several sensors on AC MGs is costly and increases AC MG ripple, integrating a minimum number of cost-effective sensors is preferred. In this paper, a joint-estimating advanced augmented-Kalman filter (KF) to estimate the current of the AC MG and unknown time-varying loads from the noisy measurement of the AC bus voltage is developed. The proposed approach also provides smooth and noise-less information from the measured voltage. The presented method has less complexity to handle and as a robust approach, it would be capable of dealing with uncertainties due to the load, which can be linear, nonlinear, or unbalanced. The joint-estimating augmented-KF outputs can be then utilized in the monitoring, fault detection, and control design purposes. The developed framework is tested on an AC MG supplying time-varying load and numerical results verify the applicability and accuracy of the developed technique to estimate the load and filter currents.

**Keywords**— AC microgrid (MG); Joint estimation; Kalman filter, Unknown time-varying load.

## I. INTRODUCTION

Transferring electricity for a long distance is generally a hard task and economically inappropriate, which led to a new tendency of supplying power in a form of islanding mode microgrid (MG) [1]. An MG, which can be either of alternating current (AC) type, direct current (DC) type, or even the hybrid AC/DC type, includes renewable energy resources, storage devices, and AC or DC loads [2], [3]. In the AC MGs, the main challenging issue is regulating the frequency and voltage of the AC bus to securely and reliably supply the load [4]. Thereby, distributed generators (DGs) of the AC MG are in charge of controlling current, voltage, and frequency on their own without any support from the large main grid [4].

Historically, proportional-integral (PI) controllers are utilized for voltage and current control loop [5]. On the other hand, the rotating  $dq0$  reference framework by decoupling real and reactive power control and reducing the computational burden is preferred. Thereby, proportional-resonant (PR) controller is suggested to improve the power quality and mitigate the total harmonic distortion (THD) [6]. Moreover, the MG control should be resilient against grid disturbances and uncertainties to have a fast dynamic response to be efficient and to provide accurate voltage regulation. Thus, different nonlinear control methods such as active disturbance rejection [7], sliding mode control [8], feedback

linearization [9], and state bounds constrained dynamic control [10] were presented. Almost all of the nonlinear methods, which theoretically assure the stability, require that all states are available. Moreover, some of the control approaches use the information of the loads' currents. To measure the states and time-varying parameters, it is necessary to install several sensors, which is costly and undesirably increases the system complexity. Additionally, installing current sensors degrades the ripple filtering effect [11]. Thereby, it is preferred to install a low number of sensors and estimate the other parameters needed in the control law. One approach to effectively estimate the parameters is Kalman filter (KF), which is robust against stochastic white noise [12]–[14]. The KF has been used in power electronics and systems, for instance, inductor motors' flux of rotor [15], permanent magnet (PM) flux in permanent magnet synchronous machines (PMSM) [16], primary winding current in power transformers [17], and the state-of-charge (SoC) of electrical energy storage systems of the battery type [18], and load power in DC MGs [19].

Aiming at the above-mentioned problems for the AC MG and successful implementation of KFs, this paper develops a cost-effective augmented-KF for the AC MG states and loads' currents estimation. Based on the suggested approach, less measuring instruments are required while it prevents the ripple filtering problem. Also, estimating the loads' currents in an online way would result in a framework to monitor the AC MG system. The loads' currents are taken as new artificial states associated with the vector of the state of the AC MG so that they can be estimated. Owing to the innate resiliency of joint-estimating augmented-KF when facing measurements associated with noise and removing any additional current sensors, the developed approach is both practical and economical. The presented joint-estimating augmented-KF is then utilized on an AC MG, whose voltage should be determined. The measured voltage would be transformed through the Park's transformation to provide the information in the  $dq0$  framework and then, the augmented system states are estimated.

The remainder of the paper is organized as follows: Section II provides the mathematical modelling of the AC MG, while the KF technique is proposed in section III. Section IV includes the results obtained from simulating the developed technique on a case study to verify the effectiveness and efficiency of the suggested method. The related conclusion beside the future works are also included in Section V.

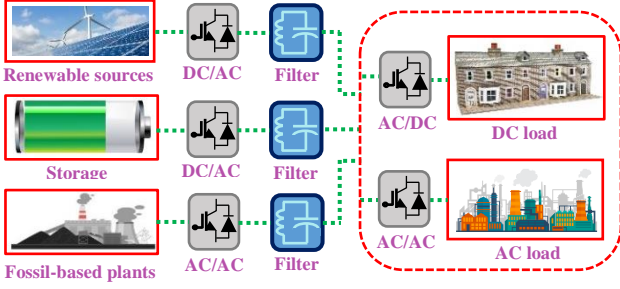

Fig. 1: Illustration of a stand-alone AC MG.

## II. AC MICROGRID TOPOLOGY AND DYNAMIC

A general AC MG including different linear and nonlinear loads, different AC and DC sources, and energy storage systems is depicted in Fig. 1.

More specifically, consider that a stand-alone three-leg AC MG is fed using a tightly regulated DC supply connected to the AC MG via a DC/AC inverter. Each leg of the inverter comprises an anti-parallel IGBT and diode-based bidirectional switches to generate a controllable terminal voltage. The AC MG feeds several unknown three-phase loads, which in general can be linear, nonlinear, unbalanced, or time-varying, as illustrated in Fig. 2. The system dynamics within the  $dq0$  rotating reference frame for the AC MG given in Fig 3 are as follows:

$$\begin{cases} C_f \frac{dv_{od}}{dt} = -i_{od} + \omega C_f v_{oq} + i_{id} \\ C_f \frac{dv_{oq}}{dt} = -i_{oq} - \omega C_f v_{od} + i_{iq} \\ L_f \frac{di_{id}}{dt} = -v_{od} - r_f i_{id} + \omega L_f i_{iq} + v_{id} \\ L_f \frac{di_{iq}}{dt} = -v_{oq} - r_f i_{iq} - \omega L_f i_{id} + v_{iq} \end{cases} \quad (1)$$

where  $i_{od}$  and  $i_{oq}$  are the load currents,  $i_{id}$  and  $i_{iq}$  are the inverter currents, and  $v_{od}$  and  $v_{oq}$  are the load voltages in the  $dq0$  framework. Also,  $C_f$ ,  $r_f$ , and  $L_f$  are the capacitance, resistive, and inductive terms of the RLC filter. The load currents  $i_{od}$  and  $i_{oq}$  are unknown. By defining the state vector  $x = [x_1 \ x_2 \ x_3 \ x_4]^T = [v_{od} \ v_{oq} \ i_{id} \ i_{iq}]^T$ , and the input vector  $u = [u_1 \ u_2]^T = [v_{id} \ v_{iq}]^T$ , external disturbance input  $d = [d_1 \ d_2]^T = [i_{od} \ i_{oq}]^T$ , the dynamics (1) are re-written in the following state-space representation:

$$\begin{cases} \dot{x}_1 = \omega x_2 + \frac{1}{C_f} x_3 - \frac{1}{C_f} d_1 \\ \dot{x}_2 = -\omega x_1 + \frac{1}{C_f} x_4 - \frac{1}{C_f} d_2 \\ \dot{x}_3 = -\frac{1}{L_f} x_1 - \frac{r_f}{L_f} x_3 + \omega x_4 + \frac{1}{L_f} u_1 \\ \dot{x}_4 = -\frac{1}{L_f} x_2 - \frac{r_f}{L_f} x_4 - \omega x_3 + \frac{1}{L_f} u_2 \end{cases} \quad (2)$$

To perform a highly reliable control action and monitoring, it is necessary to gather the information of the states and disturbances of the AC MG.

By connecting the sensors of current in series, the output impedance would rise while it diminishes the ripple filtering [11].

It is also noteworthy that adding any additional sensor may complicate the system and cause more expenses. Moreover, practical sensors are non-ideal with the stochastic noise. Therefore, it is preferred to estimate the currents of the AC MG, including  $i_{id}$ ,  $i_{iq}$ ,  $i_{od}$ , and  $i_{oq}$  from the noisy measurements of its voltages  $v_{od}$  and  $v_{oq}$ .

In the following, a KF method with the so-called ‘‘joint estimation’’ is developed for the AC MG dynamics (2).

## III. DEVELOPED AUGMENTED-KALMAN FILTER

This section is devoted to developing the conventional KF for the case study of the AC MG. The developed KF should be able to I) estimate the values of the states  $x_3$  and  $x_4$ , II) smooth the noisy values of the states  $x_1$  and  $x_2$ , and III) estimate the external disturbances  $d_1$  and  $d_2$ . To achieve this goal, the unknown external disturbance input vector  $d$  is included in the augmented states of the KF. Such an approach is known as the joint estimation method, and it is shown to be effective in both estimating the states and disturbances of a system [13]. Accordingly, the augmented state vector of the KF can be stated as follows:

$$\dot{x}_{KF} = \begin{bmatrix} \dot{x} \\ \dot{d} \end{bmatrix} \quad (3)$$

Since the dynamics of the loads are unknown, the conventional way is to consider as [13]:

$$\dot{d} = 0 \quad (4)$$

Letting  $d = [d_1, d_2]^T$  and substituting (2) and (4) into the dynamics of the augmented state (3), the state-space model of augmented-KF is obtained as (5):

$$\begin{aligned} \dot{x}_{KF} &= \begin{bmatrix} 0 & \omega & \frac{1}{C_f} & 0 & -\frac{1}{C_f} & 0 \\ -\omega & 0 & 0 & \frac{1}{C_f} & 0 & -\frac{1}{C_f} \\ -\frac{1}{L_f} & 0 & -\frac{r_f}{L_f} & \omega & 0 & 0 \\ 0 & -\frac{1}{L_f} & -\omega & -\frac{r_f}{L_f} & 0 & 0 \\ 0 & 0 & 0 & 0 & 0 & 0 \\ 0 & 0 & 0 & 0 & 0 & 0 \end{bmatrix} x_{KF} \\ &+ \begin{bmatrix} 0 & 0 \\ 0 & 0 \\ \frac{1}{L_f} & 0 \\ 0 & \frac{1}{L_f} \\ 0 & 0 \\ 0 & 0 \end{bmatrix} u = Ax_{KF} + Bu \end{aligned} \quad (5)$$

Also, the output vector  $y = [y_1 \ y_2]^T = [v_{od} \ v_{oq}]^T$  of the augmented-KF technique can be re-stated using the augmented state vector as below:

$$y = \begin{bmatrix} 1 & 0 & 0 & 0 & 0 & 0 \\ 0 & 1 & 0 & 0 & 0 & 0 \end{bmatrix} x_{KF} = Hx_{KF} \quad (6)$$

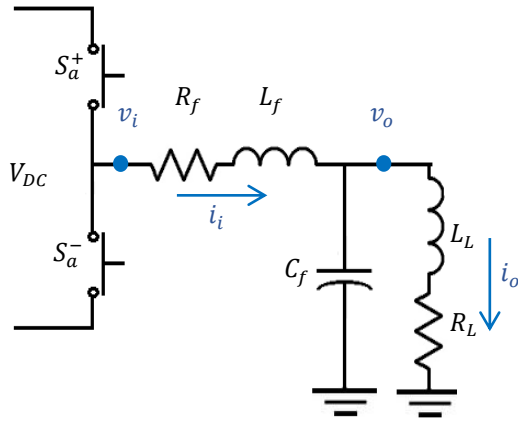

Fig. 2: The simplified schematic of one leg of the AC MG.

By recalling (5) and (6) and integrating the system and measurement noises, respectively denoted by  $w$  and  $v$ , (7) is obtained.

$$\begin{cases} \dot{x}_{ekf} = Ax_{KF} + Bu + w \\ y = Hx_{KF} + v \end{cases} \quad (7)$$

where  $w$  and  $v$  are considered white noises with zero mean and co-variance matrices  $Q$  and  $R$ , respectively indicate the associated covariance matrices.

Comparing (2) with (7) reveals that the original  $dq0$  system representation has five states, meanwhile the augmented system in augmented-KF contains 7 states.

The forward Euler technique is used to discretize the presented model in (7) as:

$$\begin{cases} x_{KF,k+1} = (I + T_s A)x_{KF,k} + TBu_k + w_k \\ y_k = Hx_{KF} + v_k \end{cases} \quad (8)$$

where  $T_s$  denotes the discretizing time and the discrete sample number is indicated by  $k$ . The developed joint-estimating-KF method is briefly stated as below:

- **Time Update**

$$\begin{aligned} \hat{x}_{KF,k}^- &= \hat{x}_{KF,k-1} + (I + T_s A)x_{KF,k} + TBu_k \\ P_{KF,k}^- &= AP_{KF,k-1}A^T + Q_{k-1} \end{aligned} \quad (9)$$

- **Measurement Update**

$$\begin{aligned} K_{KF,k} &= P_{KF,k}^- H_k^T (H_k P_{KF,k}^- H_k^T + R_k)^{-1} \\ \hat{x}_{KF,k} &= \hat{x}_{KF,k}^- + K_k (y_k - H \hat{x}_{KF,k}^-) \\ P_{KF,k} &= (I - K_k H_k) P_{KF,k}^- \end{aligned} \quad (10)$$

where the predicted states vector is denoted by  $\hat{x}_{KF,k}^-$  and  $P_{KF,k}^-$  indicates the predicted covariance matrix relating to the states ahead of taking into account the measurements.

Furthermore, having taken into account the measurements, the estimated states vector is shown by  $\hat{x}_{KF,k}$  and the estimated states covariance matrix is indicated by  $P_{KF,k}$ . The gain of the filter is expressed by  $K_{KF,k}$ . This parameter specifies to what extent the predictions must be updated in every instance.

The scheme of the proposed measurement and estimation technique is illustrated in Fig. 3. After measuring the voltages of the AC bus, the Park's transformation is utilized to obtain the information in the  $dq0$  framework. Then, the suggested joint-estimating augmented-KF is utilized to I) estimate the currents of the filter and unknown loads and II) provide the noise-less information of the noisy measurements. Then, the online computed states and disturbances can be directly utilized for the monitoring, fault detection, and control issues.

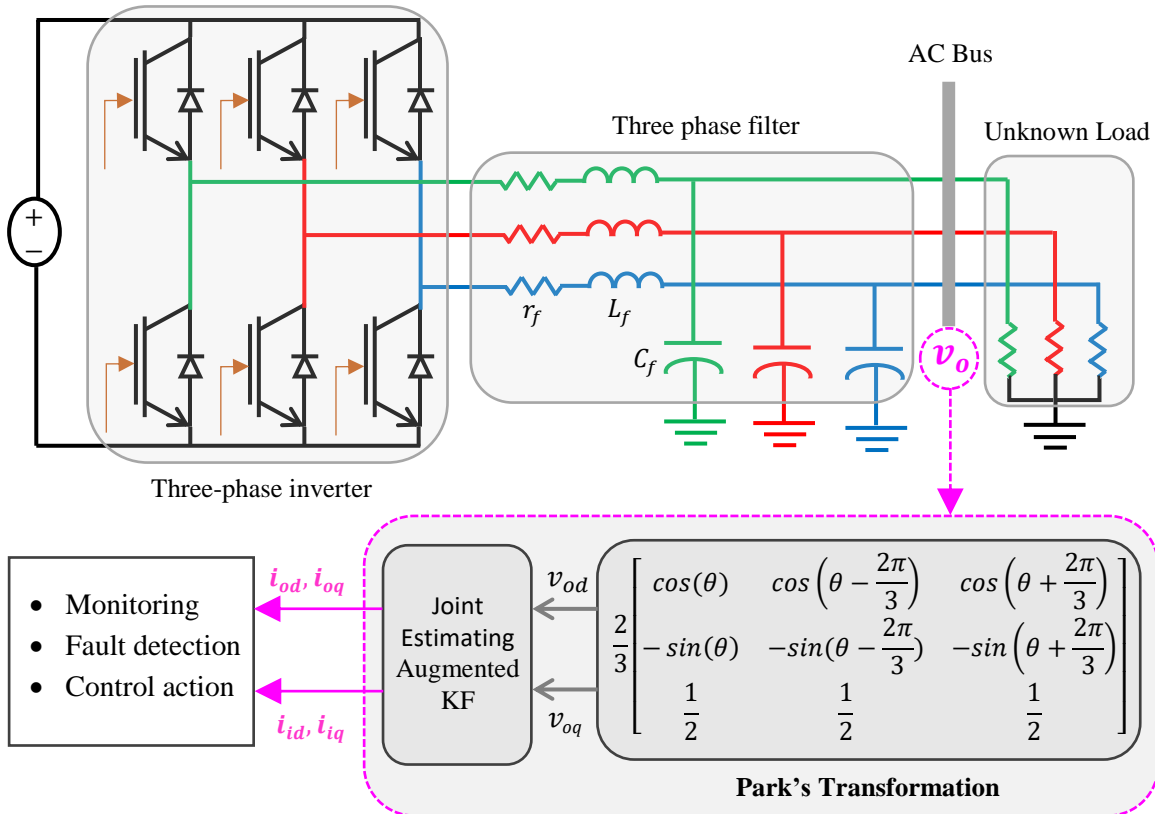

Fig. 3: The block-diagram of the presented approach.

#### IV. SIMULATION RESULTS

This section presents the results obtained from simulating the developed method in this paper. In this respect, Table I represents the parameters of the studied AC MG.

$x_{KF,0} = [100 \ 100 \ 0 \ 0 \ 0 \ 0]^T$  shows the augmented states initial values to perform the estimation. Moreover, (11) represents the values of  $R$ ,  $Q$ , and  $P_{KF,0}$ :

$$\begin{aligned} R &= 10^2 I \\ Q &= 5 \times 10^{-3} I \\ P_{KF,0} &= 10I \end{aligned} \quad (11)$$

The developed KF technique is simulated in two different scenarios to verify its performance. The load characteristics change promptly and slowly in the first and second scenarios, respectively. In both scenarios, the control inputs are fixed as  $u_1 = u_2 = 250 \text{ V}$ . The reason is that, in this paper, only the state measurement and estimation are considered and voltage sourced control issue is not addressed.

**Scenario 1 (Stepwise variation of load):** The load varies abruptly at several instances which is quite usual in practical applications when some loads are connected or disconnected to/from the AC MG. The joint-estimating KF is applied to estimate the currents and voltages of the AC MG. Fig. 4 illustrates the actual as well as the estimated values of the augmented states.

Fig. 4 reveals that the suggested augmented-KF estimates the augmented states fast and accurately. Particularly, it can be implied from Fig. 4 that once the load is quickly altered, an abrupt error would appear in the output of the developed augmented-KF, but it is treated fast. After that, the error of states estimation reaches zero in 20 ms.

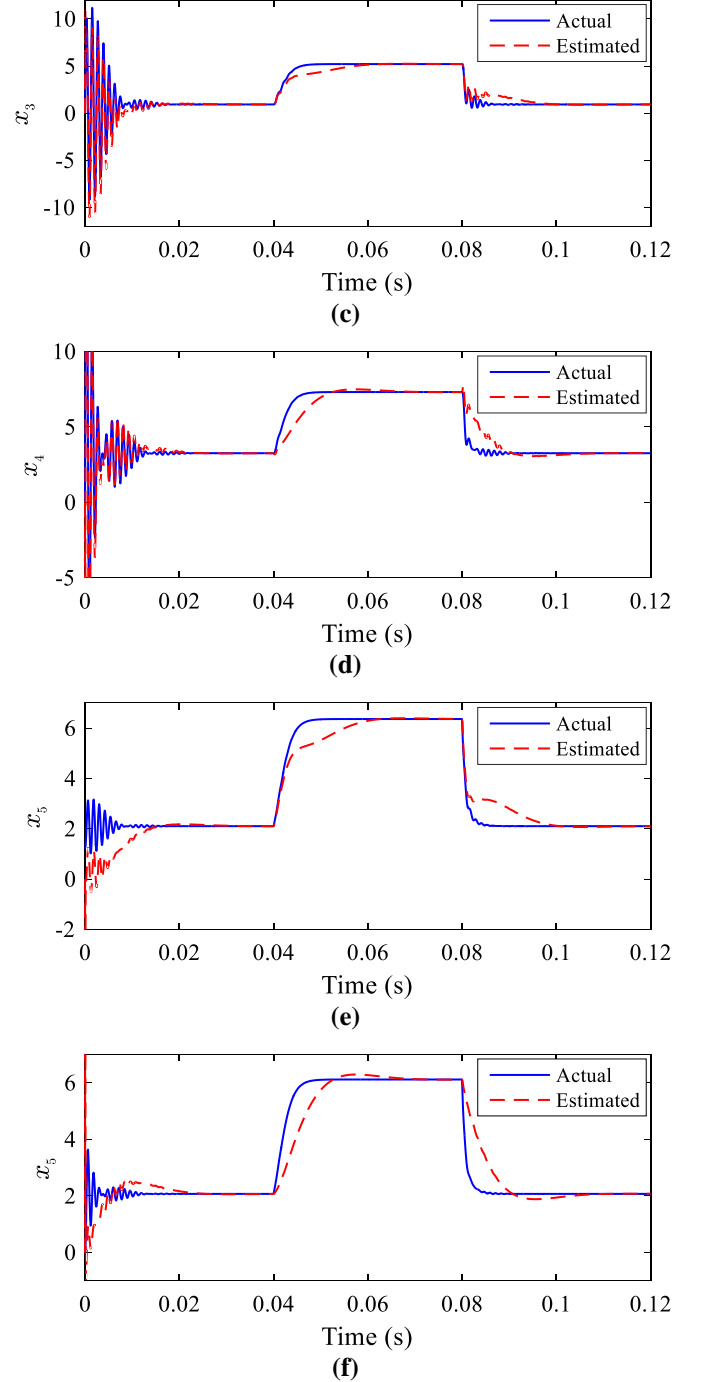
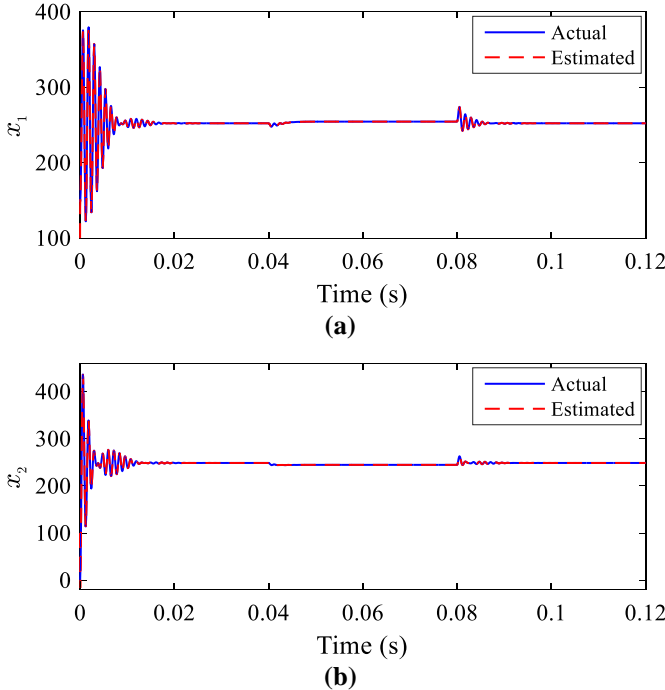
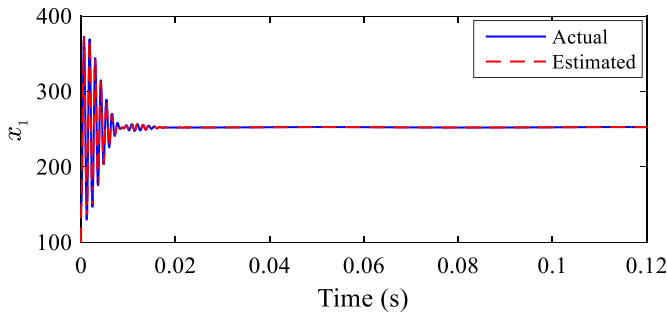

Fig. 4: Augmented system states of the AC MG\_Scenario 1. (a).  $v_{od}$ , (b).  $v_{oq}$ , (c).  $i_{id}$ , (d).  $i_{iq}$ , (e).  $i_{od}$ , (f).  $i_{oq}$ .

Table I. SYSTEM AND LOAD PARAMETERS.

Parameter	Value	Parameter	Value
$u_1, u_2$	250 V	$C_f$	15 $\mu\text{F}$
$r_f$	0.2 $\Omega$	$r_{load}$	40~120 $\Omega$
$L_f$	2.4 mH	$\omega$	50 Hz

**Scenario 2 (periodic slowly variation of load):** This case investigates the slow change of the load characteristics. This slow change is originated from the fact that loads are dependent on different factors such as temperature in practical applications. Fig. 5 depicts the actual and estimated values of the augmented states of the KF.



(a)

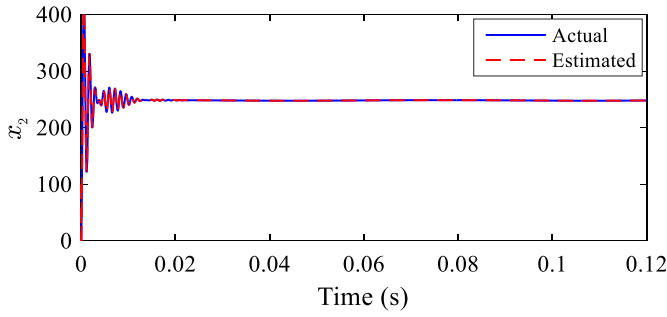

(b)

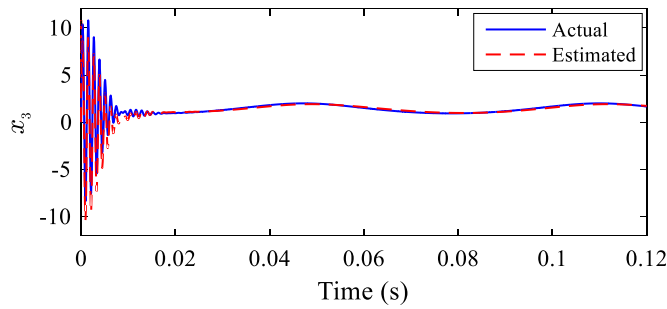

(c)

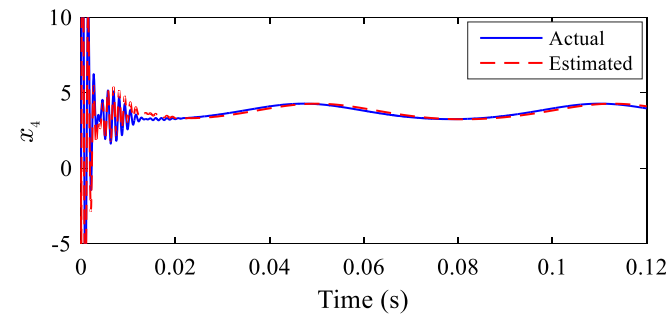

(d)

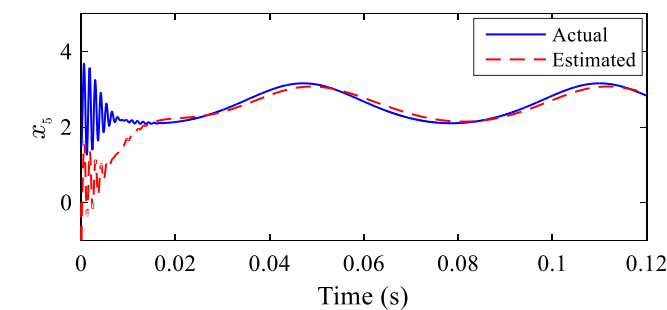

(e)

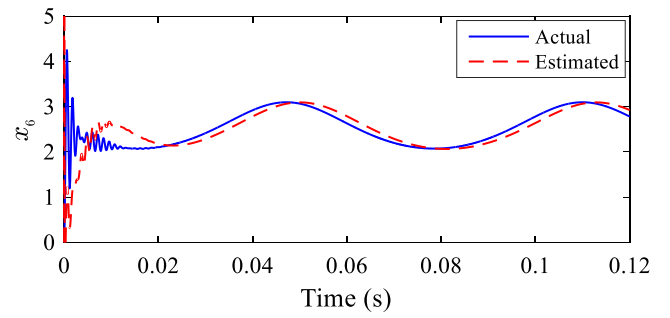

(f)

Fig. 5: Augmented system states of the AC MG\_Scenario 2. (a).  $v_{od}$ , (b).  $v_{oq}$ , (c).  $i_{id}$ , (d).  $i_{iq}$ , (e).  $\dot{i}_{od}$ , (f).  $\dot{i}_{oq}$ .

Fig 5 reveals that the KF accurately estimates slowly varying loads. It is inferred from Fig. 5 that the estimations have one step delay with respect to the actual value.

## V. CONCLUSION

In this paper, a joint-estimating augmented-KF was developed for the filters' and loads' currents in AC MGs estimation. The suggested approach avoids installing current sensors, which reduces the cost of practical systems. Using the presented augmented-KF algorithm, both the system states and the uncertain load currents in the presence of noisy measurements were estimated. The numerical results illustrated the capability of the considered augmented-KF in estimating states and unknown loads' characteristics for both cases of abrupt and continuous variations. The presented technique in this paper can be extended as follows: I), other types of estimators such as Luenberger observer or disturbance observer can be utilized. II), selecting optimal values for the augmented-KF matrices is an important topic.

## ACKNOWLEDGEMENT

Mohammad Javadi and João P. S. Catalão acknowledge the support by FEDER funds through COMPETE 2020 and by Portuguese funds through FCT, under 02/SAICT/2017 (POCI-01-0145-FEDER-29803).

## REFERENCES

- [1] N. Vafamand, M. H. Khooban, T. Dragicevic, and F. Blaabjerg, "Networked Fuzzy Predictive Control of Power Buffers for Dynamic Stabilization of DC Microgrids," *IEEE Trans. Ind. Electron.*, vol. 66, no. 2, pp. 1356–1362, 2019.
- [2] N. Vafamand, S. Yousefzadeh, M. H. Khooban, J. D. Bendtsen, and T. Dragicevic, "Adaptive TS Fuzzy-Based MPC for DC Microgrids With Dynamic CPLs: Nonlinear Power Observer Approach," *IEEE Syst. J.*, pp. 1–8, 2018.
- [3] N. Vafamand, M. H. Khooban, T. Dragicevic, F. Blaabjerg, and J. Boudjadar, "Robust non-fragile Fuzzy Control of uncertain DC Microgrids Feeding Constant Power Loads," *IEEE Trans. Power Electron.*, pp. 1–1, 2019.
- [4] N. Vafamand, M. H. Khooban, T. Dragicevic, J. Boudjadar, and M. H. Asemami, "Time-Delayed Stabilizing Secondary Load Frequency Control of Shipboard Microgrids," *IEEE Syst. J.*, pp. 1–9, 2019.
- [5] J. Dannehl, F. W. Fuchs, and P. B. Thogersen, "PI State Space Current Control of Grid-Connected PWM Converters With LCL Filters," *IEEE Trans. Power Electron.*, vol. 25, no. 9, pp. 2320–2330, Sep. 2010.
- [6] J. C. Vasquez, J. M. Guerrero, M. Savaghebi, J. Eloy-Garcia, and R. Teodorescu, "Modeling, Analysis, and Design of Stationary-Reference-Frame Droop-Controlled Parallel Three-Phase Voltage Source Inverters," *IEEE Trans. Ind. Electron.*, vol. 60, no. 4, pp. 1271–1280, Apr. 2013.
- [7] R. Errouissi and A. Al-Durra, "A Novel Control Technique for Grid-tied Inverters Considering Unbalanced Grid Voltage Conditions and Control Input Saturation," *IEEE Trans. Sustain. Energy*, pp. 1–1, 2018.

- [8] H. R. *Baghaee*, M. Mirsalim, G. B. Gharehpetian, and H. A. Talebi, "A Decentralized Power Management and Sliding Mode Control Strategy for Hybrid AC/DC Microgrids including Renewable Energy Resources," *IEEE Trans. Ind. Inform.*, pp. 1–1, 2017.
- [9] Dong-Eok Kim and Dong-Choon Lee, "Feedback Linearization Control of Three-Phase UPS Inverter Systems," *IEEE Trans. Ind. Electron.*, vol. 57, no. 3, pp. 963–968, Mar. 2010.
- [10] Q.-C. *Zhong*, G. C. Konstantopoulos, B. Ren, and M. Krstic, "Improved Synchronverters with Bounded Frequency and Voltage for Smart Grid Integration," *IEEE Trans. Smart Grid*, vol. 9, no. 2, pp. 786–796, Mar. 2018.
- [11] Q. Xu, C. *Zhang*, C. Wen, and P. Wang, "A Novel Composite Nonlinear Controller for Stabilization of Constant Power Load in DC Microgrid," *IEEE Trans. Smart Grid*, pp. 1–1, 2018.
- [12] N. Vafamand, M. M. Arefi, and A. Khayatian, "Nonlinear system identification based on Takagi-Sugeno fuzzy modeling and unscented Kalman filter," *ISA Trans.*, vol. 74, pp. 134–143, Feb. 2018.
- [13] B. *Safarinejadian* and N. Vafamand, "Kalman Randomized Joint UKF Algorithm for Dual Estimation of States and Parameters in a Nonlinear System," *J. Electr. Eng. Technol.*, vol. 10, no. 3, pp. 1212–1220, May 2015.
- [14] N. *Vafamand*, S. Yousefzadeh, M. H. Khooban, J. D. Bendtsen, and T. Dragičević, "EKF for Power Estimation of Uncertain Time-Varying CPLs in DC Shipboard MGs," in *IECON 2018-44th Annual Conference of the IEEE Industrial Electronics Society*, 2018, pp. 3413–3418.
- [15] M. Barut, R. *Demir*, E. Zerdali, and R. Inan, "Real-Time Implementation of Bi Input-Extended Kalman Filter-Based Estimator for Speed-Sensorless Control of Induction Motors," *IEEE Trans. Ind. Electron.*, vol. 59, no. 11, pp. 4197–4206, Nov. 2012.
- [16] Y. Shi, K. *Sun*, L. Huang, and Y. Li, "Online Identification of Permanent Magnet Flux Based on Extended Kalman Filter for IPMSM Drive With Position Sensorless Control," *IEEE Trans. Ind. Electron.*, vol. 59, no. 11, pp. 4169–4178, Nov. 2012.
- [17] F. Naseri, Z. Kazemi, M. M. Arefi, and E. Farjah, "Fast Discrimination of Transformer Magnetizing Current From Internal Faults: An Extended Kalman Filter-Based Approach," *IEEE Trans. Power Deliv.*, vol. 33, no. 1, pp. 110–118, Feb. 2018.
- [18] R. Xiong, H. He, F. *Sun*, and K. Zhao, "Evaluation on State of Charge Estimation of Batteries With Adaptive Extended Kalman Filter by Experiment Approach," *IEEE Trans. Veh. Technol.*, vol. 62, no. 1, pp. 108–117, Jan. 2013.
- [19] S. Yousefzadeh, J. D. Bendtsen, N. Vafamand, M. H. Khooban, T. Dragičević, and F. Blaabjerg, "EKF-based Predictive Stabilization of Shipboard DC Microgrids with Uncertain Time-varying Loads," *J. Emerg. Sel. Top. Power Electron.*, 2018.