



Aalborg Universitet

AALBORG UNIVERSITY
DENMARK

Time Dependence in Flow Through Fissured Samples of White Chalk

Thorsen, Grete

Published in:

The Interplay between Geotechnical Engineering and Engineering Geology : Proceedings of the Eleventh European Conference on Soil Mechanics and Foundation Engineering, Copenhagen, 28 May - 1 June 1995 : XI ECSMFE

Publication date:
1995

Document Version
Publisher's PDF, also known as Version of record

[Link to publication from Aalborg University](#)

Citation for published version (APA):

Thorsen, G. (1995). Time Dependence in Flow Through Fissured Samples of White Chalk. In *The Interplay between Geotechnical Engineering and Engineering Geology : Proceedings of the Eleventh European Conference on Soil Mechanics and Foundation Engineering, Copenhagen, 28 May - 1 June 1995 : XI ECSMFE: DGF-bulletin 11* (pp. 291-296). Dansk Geoteknisk Forening.

General rights

Copyright and moral rights for the publications made accessible in the public portal are retained by the authors and/or other copyright owners and it is a condition of accessing publications that users recognise and abide by the legal requirements associated with these rights.

- Users may download and print one copy of any publication from the public portal for the purpose of private study or research.
- You may not further distribute the material or use it for any profit-making activity or commercial gain
- You may freely distribute the URL identifying the publication in the public portal -

Take down policy

If you believe that this document breaches copyright please contact us at vbn@aub.aau.dk providing details, and we will remove access to the work immediately and investigate your claim.

Time dependence in flow through fissured samples of White Chalk.

[86]

Grete Thorsen

Aalborg University, Denmark

SYNOPSIS: This paper presents results of flow tests carried out with blocks of White Chalk. The block samples were $30 \times 30 \times 30 \text{ cm}^3$ and $75 \times 75 \times 75 \text{ cm}^3$ and they contained fissures as in the natural deposits. The purpose of the test program was to investigate the flow properties of fissured material. For the actual very low values of stresses the results, however, indicate that the variations in flow properties are more dependent on the time than on the effective stresses and the flow pressure.

1. INTRODUCTION

In the North Sea a reservoir rock for oil and gas is formed by the "Chalk Group", which is chalk deposits containing inhomogenities and fissures.

To determine the permeability of chalk in the laboratory small cores from borings are normally used. The results of these tests provide information about the permeability of the homogeneous, unfissured material only.

The purpose of the actual test program has been to measure the flow properties of blocks containing inhomogenities and fissures (Thorsen, 1992).

2. THE MATERIAL

The material tested is White Chalk from Senonian. The samples were extracted from Rørdal Chalk quarry near Aalborg, where the deposits of White Chalk are exposed to the surface.

White Chalk is a very fine-grained rock, consisting mainly of chalk. The structure of the tested material is very similar to the structure of the "Chalk Group" from the North Sea.

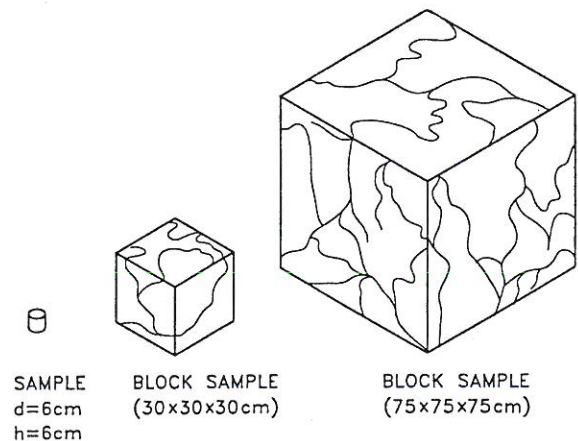

Fig. 1. Size of the block samples.

Results of classification tests carried out with small samples from Rørdal chalk quarry are:

Water content	$w = 28 - 30 \%$
Unit weight	$\gamma = 19.7 - 18.8 \text{ kN/m}^3$
Void ratio	$e = 0.76 - 0.95$
Porosity	$n = 0.43 - 0.4$
Unit weight of solids	$\gamma_s = 27.1 \text{ kN/m}^3$
Calcareous content	$k_a = 97 - 99.5 \%$
Degree of saturation	$S_r = 1$

Tests on small samples have been carried out to determine the flow properties of the matrix.

Oedometer tests have shown a hydraulic conductivity $K_A = k \times \frac{g}{v} = 10^{-10} - 10^{-12} m/sec$, corresponding to a permeability $k = 10^{-5} - 10^{-7}$ darcy. $v = 10^{-6} m^2/sec$, the viscosity of water at 20° C. $g = 9.81 m/sec^2$, the acceleration of gravity.

A flow test has been carried out in the triaxial apparatus at an all round pressure of 400 kPa and a flow pressure of 25 - 30 kPa. This test showed a hydraulic conductivity $K_A = 2 \times 10^{-11} m/sec$, corresponding to a permeability $k = 2 \times 10^{-6}$ darcy.

3. CUTTING AND TRANSPORTATION

The blocks have been sawed out with a fretsaw under a constant flush of water. During transportation the blocks were packed in special boxes in order to minimize the evaporation from the surface and to prevent the existing fissures from opening because of the reduced stresses.

The transport boxes were wooden boxes lined with rubber mats. As soon as one side of a block was sawed out the side of the transport box was mounted and a tight fitting was obtained by assembling.

The five sides of the block were sawed out and packed before the block was sawed free of the deposits in the quarry. The blocks were sawed out just above the natural water table and because of the capillarity the material is assumed to be saturated at the moment of disconnection from the ground.

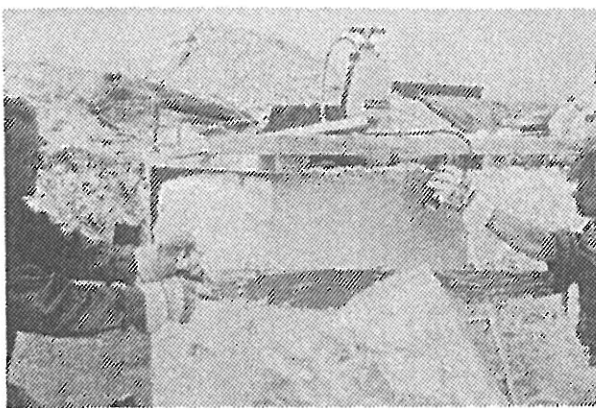

Fig. 2. Cutting of the block samples.

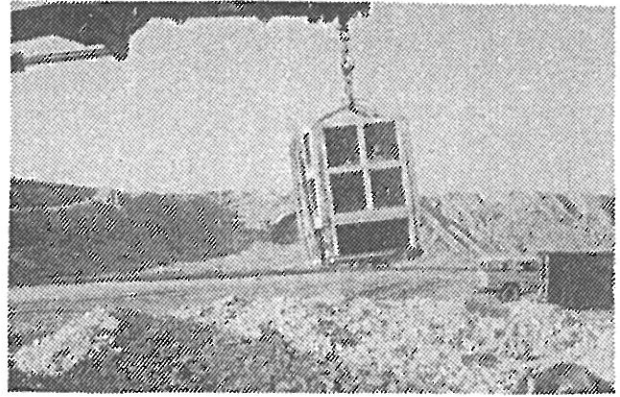

Fig. 3. Transportation of the block samples.

4. EQUIPMENT IN THE LABORATORY

After arrival to the laboratory the blocks were placed in special laboratory boxes by changing the sides of the transport boxes one by one with a side of the laboratory box.

The laboratory boxes were constructed from the following principle:

Each side in the box was interchangeable with any of the other sides.

The inside of each side in the box was coated with a rubber pad (Latex), through which a pressure on the sample could be established by air (or water). At two sides of the sample a permeable layer, a filter cloth, was placed between the sample and the rubber pad to ensure drainage.

The all round pressure on the blocks was established by air pressures in the rubber pads. The bottom pad contained water.

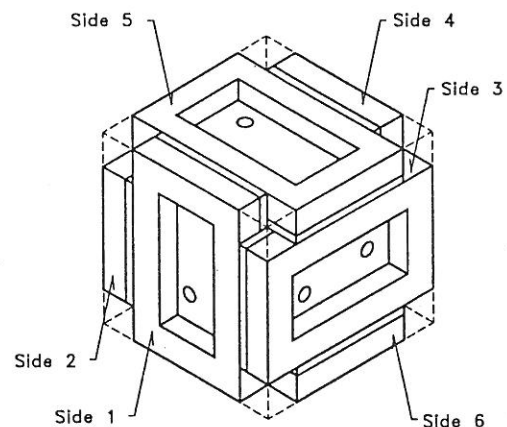

Fig. 4. Laboratory box.

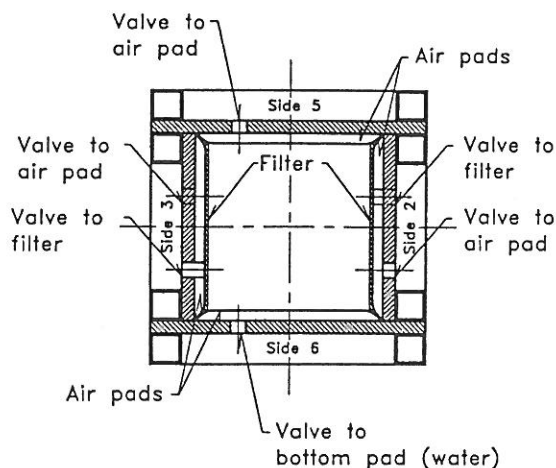

Fig. 5. Vertical section of the laboratory box.

During the consolidation an all round pressure was established in the rubber pads while drainage was allowed through the filter cloth.

During the flow tests a pressure was established in the one filter side and drainage allowed through the other filter side. The water flow through the sample was registered in specially constructed volumenometers. The all round pressure as well as the flow pressure and the water flow through the sample were registered during the tests.

5. FLOW TESTS

5.1 The Material

Flow tests were carried out on 5 block samples. 3 samples of 30 x 30 x 30 cm³ and 2 samples of 75 x 75 x 75 cm³. The samples were weighed and measured just after the arrival to the laboratory. The unit weights were determined to $\gamma = 18.8 - 19.8 \text{ kN/m}^3$, corresponding to the unit weights determined for the saturated small samples.

5.2 The Purpose

The purpose of the tests was

- to analyse the variation of flow properties with the effective stress
- to analyse the influence of fissures on the flow properties
- to analyse the variation of the flow properties in different directions.

5.3 The test procedure

In the actual test setup it was possible to establish an all round pressure up to 140 kPa and a flow pressure up to 50 kPa, corresponding to a difference in head $\Delta h = 5 \text{ m}$.

An all round pressure was established on the blocks. When the consolidation process was completed, flow tests were carried out at different flow pressures.

When a series of flow tests at different all round pressures had been carried out with a flow between two opposite sides, the filter sides in the laboratory box were changed to two other opposite sides and a new series of tests was started.

5.4 Variation of flow against effective stress

After some test series were carried out the results proved not to be reproducible. Flow tests carried out in the same way at the same effective stresses, σ' , and at the same flow pressure as well as the same difference in head, Δh , gave different water flows, q , depending on when the test was carried out.

Test no.	Date	Δh m	σ' kPa
1501	24.03	3.2 - 2.7	71 - 76
1502	25.03	1.7 - 0.1	79 - 87
1503	26.03	3.3 - 0.1	71 - 87
1504	21.04	5	62
1505.1	23.07	1.2	81
1505.2	23.07	3.2	71

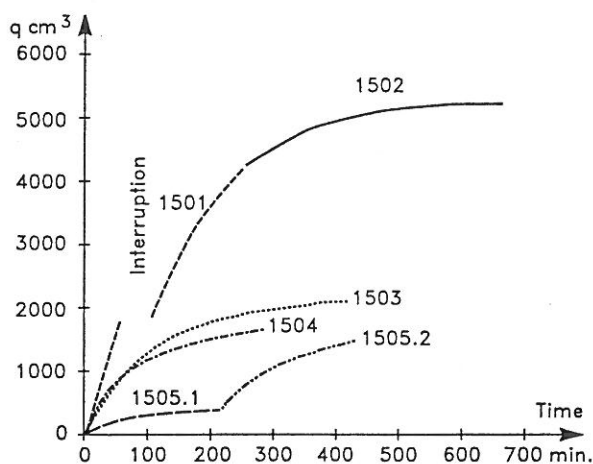

Fig. 6. Block 15 (75x75x75cm³). Results of flow tests.

Fig. 6 shows the variation in water flow against time for 5 flow tests with the same sample. If the results are correlated to the actual differences in heads between the filter sides, Δh , and the effective stresses, σ' , it is seen, that the variation in flow properties with the differences in heads and effective stresses is much lower than the variation with time.

5.5 Influence of fissures on the flow properties

The permeability of a fissured material can be expressed as a sum of the permeability of the fissures and the permeability of the matrix (Van Golf-Racht, 1982).

The permeability of the matrix is assumed to be very small compared to the permeability of the fissures. The flow through a fissure is assumed to be represented by a laminar flow between smooth parallel plates. The average flow velocity of water could then be expressed as

$$v = k \times \frac{g}{\nu} \times i = \frac{e^2}{12} \times \frac{g}{\nu} \times i$$

$$k = \frac{e^2}{12} = \text{the permeability in the fissure}$$

g = the acceleration of gravity

ν = the viscosity

i = the gradient

e = the equivalent smooth wall aperture

In the following e is used as an indication of the size of the fissure. The size of the rough-wall fissure is of another magnitude (Bandis et. al., 1986). So assuming that the entire water flow in a cubic sample with a side length l is transported through one horizontal smooth fissure we get the following:

$$\frac{Q}{e \times l} = \frac{e^2}{12} \times \frac{g}{\nu} \times \frac{\Delta h}{l} \text{ or } Q = \frac{e^3}{12} \times \frac{g}{\nu} \times \Delta h$$

Q is the flow rate, and Δh is the difference in head between the two filter sides in the block sample. The flow rate is then independent of the size of the sample, and e can be determined from the following equation:

$$e = \sqrt[3]{\frac{Q}{\Delta h} \times 12 \times \frac{\nu}{g}}$$

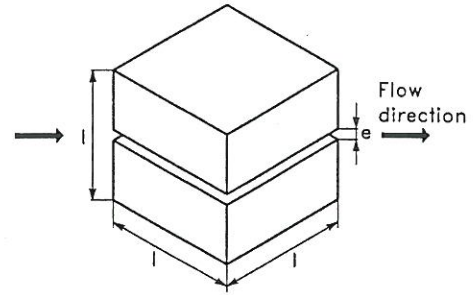

Fig. 7. Water flow through a smooth fissure e .

The hydraulic conductivity in the fissure is

$$K_e = k \times \frac{g}{\nu} = \frac{e^3}{12} \times \frac{g}{\nu}$$

The average hydraulic conductivity calculated from the area of the block is

$$K_A = \frac{e}{l} \times K_e = \frac{e^3}{12 \times l} \times \frac{g}{\nu} = \frac{Q}{l \times \Delta h}$$

If a flow test is started just after a consolidation with drainage from both filters, the flow pressure introduces a reduction in the effective stresses. Calculations of the variations of e during a flow test show an increase of e by the reduction in effective stresses. e , however, decreases again with time.

The calculated variations in e for tests no. 1501-1505 are shown in Fig. 8. in a semi logarithmic scale against time.

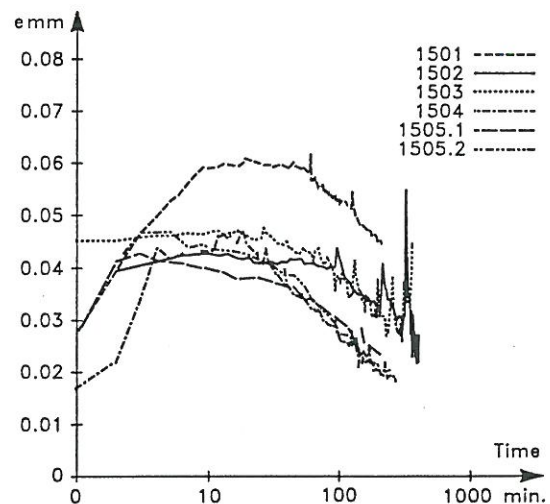

Fig. 8. Block 15. Tests no. 1501-1505. Calculated variations in e with log time.

The curve for the closure of e with time during a flow test approaches a straight line in a semi logarithmic scale.

This curvature is similar to the creep curve in a consolidation test. An expression similar to the expression set up by Moust Jacobsen for creep deformations could be set up for the variation in e during flow tests (Moust Jacobsen, 1992).

$$\Delta e = e_s \times \log\left(1 + \frac{t}{t_A}\right)$$

Δe = the variation in e

e_s = the variation in e over one decade

t = the time passed since the start of the flow test series

t_A = a reference time

In the actual tests t_A is found to be about 60 min, and may represent the time necessary to adjust for the change in effective stresses caused by the flow pressure.

In Fig. 9. the calculated values of e are plotted against $\log\left(1 + \frac{t}{60}\right)$. The curves approach straight lines with a slope of 0.04 mm/decade.

The peaks at the curves represent moments where a valve is closed, either while the flow pressure is changed or the volumeters are being emptied.

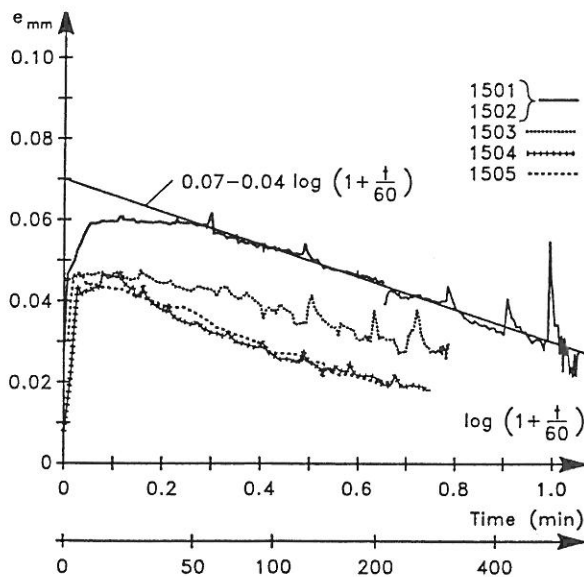

Fig. 9. Block 15, side 1-4. 1501 - 1505. Calculated variations in e against $\log\left(1 + \frac{t}{60}\right)$.

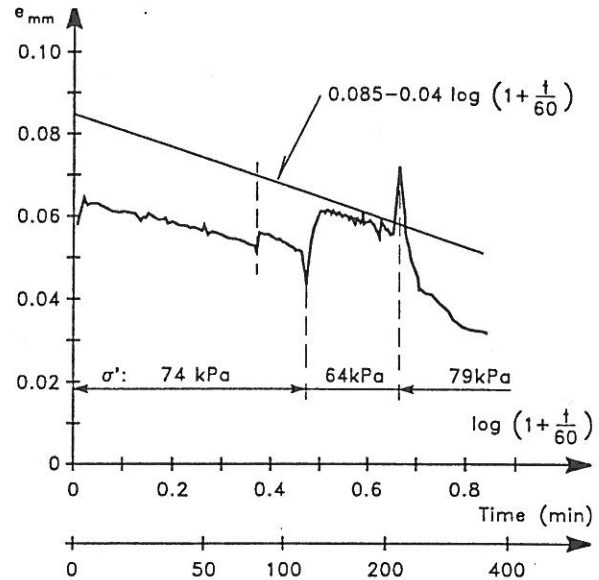

Fig. 10. Block 15, side 5-6. Calculated variations in e against $\log\left(1 + \frac{t}{60}\right)$.

Fig. 10. shows results of flow tests carried out on the same block sample, 15 ($75 \times 75 \times 75 \text{ cm}^3$), but with another flow direction.

Fig. 11. shows results of flow tests carried out on block 4 ($30 \times 30 \times 30 \text{ cm}^3$). The results indicate the same rate of decrease in e .

A decrease in e from 0.06 mm to 0.02 mm corresponds to a decrease in permeability from $k = 300$ darcy to $k = 33$ darcy, and in hydraulic conductivity from $K_e = 3 \times 10^{-3} \text{ m/sec}$ to $K_e = 0.3 \times 10^{-3} \text{ m/sec}$.

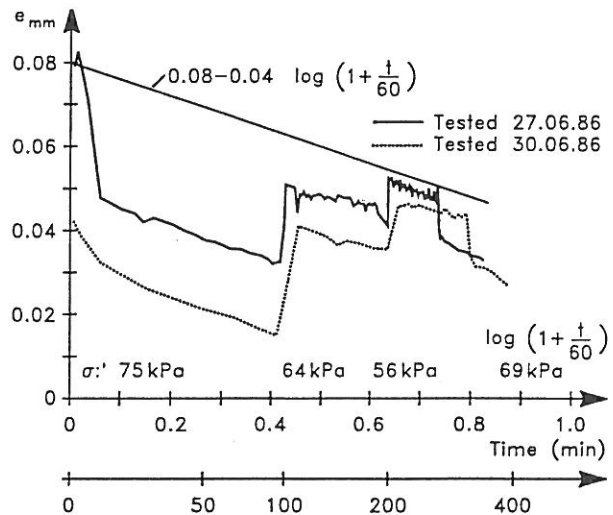

Fig. 11. Block 4, side 5-6. Calculated variations in e against $\log\left(1 + \frac{t}{60}\right)$.

From the tests on small samples the permeability of the matrix was determined to $k \sim 10^{-6}$ darcy, corresponding to a hydraulic conductivity $K_A \sim 10^{-11}$ m/sec.

In the flow tests with the block samples the lowest calculated value for e is about 0.01mm, corresponding to a permeability $k \sim 10$ darcy and a hydraulic conductivity $K_e \sim 10^{-4}$ cm/sec for the fissures. For a $75 \times 75 \times 75$ cm³ block sample this corresponds to an average hydraulic conductivity $K_A \sim 10^{-9}$ m/sec. In the actual volumenometers the accuracy, however, was not very precise at the smallest flow rates.

5.6 The variation in flow in different directions

Flow tests have been carried out in three different directions.

The calculated major values of e vary from 0.04 to 0.09 mm. The major variation in the three directions within one sample is about 0.03 mm, which is less than the observed variation with time during a flow test.

6. CONCLUSION

For ranges of stresses as low as in the actual test program, the conclusion is, that the flow properties are more dependent on the time than on the effective stresses in the sample and the flow pressure.

The calculated variations in size of fissures during a flow test plotted against time show a curve of the same shape as the creep curves during a consolidation process.

It is therefore suggested to base the calculations of the variations in size of the fissures during a flow test on a principle similar to the calculations of creep in a consolidation process.

The actual tests have been carried out with samples big enough to contain inhomogenities and fissures as in the natural deposits. Compared to nature, the block samples, however, are only small elements cut out of an entirety. The results as obtained in the laboratory may therefore not be directly transferable to the situation in nature.

7. REFERENCES

- Bandis, S. C., Makurat, A., Vik, G. (1986). Predicted and measured hydraulic conductivity of rock joints. *Norwegian Geotechnical Institute. Publication no. 164.* Oslo 1986.
- Moust Jacobsen, H. (1992). Characteristic stress conditions for clay till. (in Danish). *Proc. NGM92*, Aalborg, Danish Geotechnical Society, Bulletin 9, vol. 2. p. 461-466.
- Thorsen, G. (1992). Fissured White Chalk. Flow tests. (in Danish). *Proc. NGM92*, Aalborg, Danish Geotechnical Society, Bulletin 9, Vol. 1, 131-136.
- Van Golf-Racht, T. D. (1982): *Fundamentals of fractured reservoir engineering.* Developments in Petroleum science, 12. Elsevier S.P.C., Amsterdam.