



Aalborg Universitet

AALBORG UNIVERSITY  
DENMARK

## Information Gap Decision Theory for Scheduling of Electricity-Gas Systems in the Presence of Demand Response

Talebi , Amir ; Mirzapour-Kamanaj, Amir ; Agabalaye-Rahvar, Masoud ; Mohammadi-Ivatloo, Behnam ; Zare, Kazem; Anvari-Moghaddam, Amjad

*Published in:*  
2021 IEEE International Conference on Environment and Electrical Engineering

*DOI (link to publication from Publisher):*  
[10.1109/EEEIC/ICPSEurope51590.2021.9584543](https://doi.org/10.1109/EEEIC/ICPSEurope51590.2021.9584543)

*Publication date:*  
2021

*Document Version*  
Accepted author manuscript, peer reviewed version

[Link to publication from Aalborg University](#)

*Citation for published version (APA):*

Talebi , A., Mirzapour-Kamanaj, A., Agabalaye-Rahvar, M., Mohammadi-Ivatloo, B., Zare, K., & Anvari-Moghaddam, A. (2021). Information Gap Decision Theory for Scheduling of Electricity-Gas Systems in the Presence of Demand Response. In *2021 IEEE International Conference on Environment and Electrical Engineering : EEEIC 2021* (pp. 1-6). IEEE Press.  
<https://doi.org/10.1109/EEEIC/ICPSEurope51590.2021.9584543>

### General rights

Copyright and moral rights for the publications made accessible in the public portal are retained by the authors and/or other copyright owners and it is a condition of accessing publications that users recognise and abide by the legal requirements associated with these rights.

- Users may download and print one copy of any publication from the public portal for the purpose of private study or research.
- You may not further distribute the material or use it for any profit-making activity or commercial gain
- You may freely distribute the URL identifying the publication in the public portal -

### Take down policy

If you believe that this document breaches copyright please contact us at [vbn@aub.aau.dk](mailto:vbn@aub.aau.dk) providing details, and we will remove access to the work immediately and investigate your claim.

# Information Gap Decision Theory for Scheduling of Electricity-Gas Systems in the Presence of Demand Response

Amir Talebi  
Faculty of Electrical and Computer  
Engineering  
University of Tabriz  
Tabriz, Iran  
a.talebi@tabrizu.ac.ir

Amir Mirzapour-Kamanaj  
Faculty of Electrical and Computer  
Engineering  
University of Tabriz  
Tabriz, Iran  
a.mirzapour@tabrizu.ac.ir

Masoud Agabalaye-Rahvar  
Faculty of Electrical and Computer  
Engineering  
University of Tabriz  
Tabriz, Iran  
m.agabalaye@tabrizu.ac.ir

Behnam Mohammadi-Ivatloo  
Faculty of Electrical and Computer  
Engineering  
University of Tabriz  
Tabriz, Iran  
bmohammadi@tabrizu.ac.ir

Kazem Zare  
Faculty of Electrical and Computer  
Engineering  
University of Tabriz  
Tabriz, Iran  
kazem.zare@tabrizu.ac.ir

Amjad Anvari-Moghaddam  
Department of Energy  
Aalborg University  
Aalborg, Denmark  
aam@energy.aau.dk

**Abstract**— High-level integration of wind energy in power networks has raised the need for flexible units. Gas-fuel generators (GFG) with fast startup/shutdown and high ramp rate capability can provide the required flexibility in the operation of wind energy. However, the operation of GFGs can be affected by the limitations of the fuel transmission system. Demand response programs can decrease the effect of fuel transmission system restrictions in the operation of GFGs and as well as, increase the integration of wind energy into the electricity network. In this work, a scheduling model for electricity and gas networks considering demand response programs is presented. Uncertainties pertain to wind energy and demand response program are addressed in this model. Moreover, power to gas technology is used to prevent wind curtailment. This scheduling model is based on the information gap decision theory (IGDT) that can assess the level of risk pertains to uncertainties. The proposed framework has been simulated on two different networks to represent the effectiveness of the model.

**Keywords**— electricity and gas networks, demand response, power to gas, IGDT

## Nomenclature

### Indices:

$t, w, sup, i, pg, r, d$  Time, wind farm, gas wells, power units, PtG, gas and electrical loads

$(gm, gn), (m, n)$  Gas nodes and buses

$GF$  GFG

### Sets:

$DM, GMM, MM$  Loads, units and buses linked to bus  $m$

$PGM, WMM$  PtG and wind farm linked to bus  $m$

$PGN, SPN, RGN, RN$  PtG, gas wells, gas loads and nodes linked to node  $gm$

$GUN$

GFGs connected to node  $gm$

### Constants:

$sut_i^f, sdt_i^f$

Startup/Shutdown cost of non-GFGs

$sug_i^g, sdg_i^g$

Startup/Shutdown gas usage of GFGs

$R_i^{up}, R_i^{dn}$

Ramp up/down of unit  $i$

$X_{mn}, Pf_{mn}^{max}$

Reactance and capacity of power line

$Pe_{w,t}^f, Gl_{r,t}^B, Ps_{d,t}^B$

The predicted value of wind power, gas and electrical loads

$P_i^{max}, P_i^{min}$

Maximum and minimum limit of unit  $i$

$T_i^{on}, T_i^{off}$

Minimum ON/OFF time of unit  $i$

$a_f, b_f, c_f$

Fuel coefficients of GFGs

$Vg_{sup}^{max}, Vg_{sup}^{min}$

Maximum and minimum output of gas well

$K_{gm,gn}$

Pipeline constant

$ps_{gm}^{max}, ps_{gm}^{min}$

Pressure range of gas node

$\gamma, \lambda$

Hydrogen and  $CO_2$  coefficients

$\xi_{gas}$

Gas price

$\zeta^{shed}$

Cost of load shedding

$P_{we}$

Power of electrolyzer

### Variables:

$I_{i,t}^{on}, I_{i,t}^{off}$

ON/OFF time of unit  $i$

$q_{i,t}$

Commitment status

$Ps_{d,t}^A$	The electrical load after implementation demand response
$PDS_{d,t}$	The value of flexible loads
$f_{gm,gn,t}, Pf_{mn,t}$	Gas flow and power flow
$\delta_{m,t}$	Voltage angle of bus $m$
$F_{i,t}^{gas}$	Gas consumption of GFGs
$ps_{gm,t}$	The pressure of node $gm$
$Vg_{sup,t}$	Output of gas supplier
$STD_{i,t}^F, STU_{i,t}^F$	Shutdown/startup cost of non-GFGs
$Ps_{d,t}^{shed}$	Load shedding at time $t$
$P_{i,t}$	Output power of unit $i$
$CH_{pg,t}$	Produced methane by PtG
$Pg_{pg,t}, Pe_{w,t}$	Power dispatch of PtG and wind unit
$STU_{i,t}^G, STD_{i,t}^G$	Gas consumption of GFGs in startup/shutdown
$Co_{pg,t}$	Absorbed $CO_2$ by PtG

## I. INTRODUCTION

Over the past decades, the use of wind energy in power systems has been a growing trend. It is predicted that, by 2030 in the United States, 20% of total power production will be generated by wind energy [1]. However, variable and unpredictable (uncertain) characteristics of wind energy pose challenges in the scheduling of power systems. This issue raises the need for flexible units in order to accommodate fluctuations of wind energy. Gas-fuel generators (GFG) can increase the flexibility of the power system since they have fast response capability. Therefore, they can facilitate the utilization of wind energy. Penetration of GFGs in power system cause interdependency between gas and power systems. So, these two systems are needed to be coordinated.

Coordinated scheduling of gas and power systems has been discussed in different works. The impact of the gas delivery system on the security of the electrical systems has been evaluated in [2]. Authors of [3] have addressed the effect of gas storage in the operation of gas and power systems. The role of power to gas (PtG) technology in avoiding wind curtailment has been investigated in [4]. The piecewise approximation method has been used in [5] to linearize the gas transmission equations. Wind, GFG and PtG units have been considered as a hybrid system in [6] to participate in the energy market. In order to optimize the total costs of the electricity and gas systems, a bi-level method has been proposed in [7]. Authors of [8] have incorporated gas system constraints in the hydrothermal system scheduling problem.

Uncertainty resources (such as wind energy, load, etc.) pose great challenges in coordination gas and power systems. Reference [9] has represented a stochastic SCUC model while taking into account gas system constraints, availability state of generators/power lines and electrical load forecast error. Reference [10] has considered electricity network

reconfiguration capability in the coordinated operation of two systems through the stochastic method. Authors in [11] have used IGDT to handle wind energy uncertainty in the operation of gas and electricity networks. Authors of [12] have used the IGDT approach to address electricity price uncertainty in the scheduling of power and gas networks. In [13], district heating and gas networks, as well as wind uncertainty, have been included in the UC problem via IGDT method. In [14] and [15] robust method has been applied in the optimization of gas and power systems. Reference [14] has considered contingencies of power lines/gas pipelines and wind energy uncertainty in the introduced model. In [15], uncertainties of electrical load and wind energy, as well as PtG system, have been considered in the co-optimization model.

In cold weather, the flexible characteristic of GFGs may be less effective because the gas consumption increases for home applications. Therefore, fuel supply to GFGs is diminished due to pressure loss in gas nodes. Such conditions require a practical solution to reduce the effect of pressure drop on the output of GFGs.

The demand response (DR) program as a practical method can play a key role when the pipeline constraints restrict the operation of GFGs. DR is defined as a program that changes the consumption patterns of end-users [16]. Similar to GFGs that increase the flexibility of the system on the supply side, applying DR program enhances the flexibility of the network on the demand side. Recently DR program has gained attention in the scheduling of electricity-gas systems. An interval-based method has been presented in [17] to minimize the cost-emission of electricity-gas system under uncertainty and DR. Reference [18] has investigated the effect of coupon-based and interruptible-load based DR virtual power plant in the operation of electricity and gas systems. In [19], the effect of the DR program, wind uncertainty and CAES has been evaluated in the IGDT-based scheduling of electricity and gas networks.

However, due to various factors such as weather conditions, the actual response of end-users may be uncertain in the DR program. Accordingly, uncertainty related to the DR program should be considered in the scheduling of electricity and gas systems. This paper presents an IGDT-based scheduling model that integrates uncertainties of the DR and wind power into the scheduling problem.

The major contributions are fourfold:

- An IGDT-based scheduling model is proposed to incorporate uncertainties of the DR program and wind power into the scheduling problem.
- DR is utilized to reduce the effect of pipeline congestion and optimize total operation costs.
- PtG is used to prevent wind power curtailment.
- Two different scheduling strategies are provided, including risk-averse and risk-seeker strategies.

## II. PROBLEM FORMULATION

### A. Objective function

The objective function expressed in (1) minimizes the overall cost of the gas and electricity systems. The first term represents the generation cost and startup/shutdown cost of non-GFGs. The second term is the production cost of the gas

suppliers. And the third term pertains to the load shedding cost.

$$\min \sum_t \left[ \sum_{i \in GF} (STU_{i,t}^F + STD_{i,t}^F + F_{i,t}(P_{i,t})) + \sum_{sup} \xi_{gas} Vg_{sup,t} + \sum_d \zeta^{shed} P_{d,t}^{shed} \right] \quad (1)$$

### B. Power units constraints

Generator constraints include startup and shutdown functions, ramping limits and generation limits are given in (2)-(8), respectively. Equations (9) and (10) impose minimum up/down time limits on the GFGs and non-GFGs.

$$STU_{i,t}^F = sut_i^f (q_{i,t} - q_{i,t-1}) \quad i \notin GF \quad (2)$$

$$STD_{i,t}^F = sdt_i^f (q_{i,t-1} - q_{i,t}) \quad i \notin GF \quad (3)$$

$$STU_{i,t}^G = sug_i^g (q_{i,t} - q_{i,t-1}) \quad i \in GF \quad (4)$$

$$STD_{i,t}^G = sdg_i^g (q_{i,t-1} - q_{i,t}) \quad i \in GF \quad (5)$$

$$P_{i,t} - P_{i,t-1} \leq (1 - q_{i,t})(1 - q_{i,t-1})R_i^{up} + q_{i,t}(1 - q_{i,t-1})P_i^{min} \quad (6)$$

$$P_{i,t-1} - P_{i,t} \leq (1 - q_{i,t-1})(1 - q_{i,t})R_i^{dn} + q_{i,t-1}(1 - q_{i,t})P_i^{min} \quad (7)$$

$$P_i^{min} q_{i,t} \leq P_{i,t} \leq P_i^{max} q_{i,t} \quad (8)$$

$$(I_{i,t-1}^{on} - T_i^{on})(q_{i,t-1} - q_{i,t}) \geq 0 \quad (9)$$

$$(L_{i,t-1}^{off} - T_i^{off})(q_{i,t} - q_{i,t-1}) \geq 0 \quad (10)$$

### C. Electrical network security constraints

The security of the electrical network is evaluated by equations (11), (12) and (13). These equations represent DC power flow, power balance, and line capacity limitations, respectively. Load shedding limit and wind farm capacity are presented in (14) and (15).

$$pf_{mn,t} = (\delta_{m,t} - \delta_{n,t})/X_{mn} \quad (11)$$

$$\sum_{i \in GMM} P_{i,t} + \sum_{w \in VMM} P_{e_{w,t}} - \sum_{pg \in PGM} P_{g_{pg,t}} - \quad (12)$$

$$\sum_{d \in DM} P_{d,t}^A + \sum_{d \in DM} P_{d,t}^{shed} = \sum_{n \in MM} pf_{mn,t} - pf_{mn,t}^{max} \leq pf_{mn,t} \leq pf_{mn,t}^{max} \quad (13)$$

$$0 \leq P_{d,t}^{shed} \leq P_{d,t}^B \quad (14)$$

$$0 \leq P_{e_{w,t}} \leq P_{e_{w,t}}^f \quad (15)$$

### D. DR constraints

In the proposed DR, a specific portion of electrical loads (responsive loads) can be transferred from high-demand moments to low-demand moments. Equation (16) shows the electrical load after modification. Equation (17) determines the amount of loads that could be transferred to other times.

Also, total responsive loads will not change before and after DR. This is stated in (18).

$$Ps_{d,t}^A = Ps_{d,t}^B + PDS_{d,t} \quad (16)$$

$$PDS_{d,t} = eds_{d,t} Ps_{d,t}^B \quad (17)$$

$$\sum_t PDS_{d,t} = 0 \quad (18)$$

### E. Gas network constraints

The gas node pressure has a high/low limit, which is indicated by (19). Gas supply is limited by equation (20). Weymouth equations for pipelines are presented in (21). Equation (23) ensures gas equilibrium in gas nodes. Equation (24) shows the gas consumption of GFGs. And equations (25) and (26) represent water electrolysis and methanation process in PtG, respectively.

$$ps_{gm}^{min} \leq ps_{gm,t} \leq ps_{gs}^{max} \quad (19)$$

$$Vg_{sup}^{min} \leq Vg_{sup,t} \leq Vg_{sup}^{max} \quad (20)$$

$$f_{gm,gn,t} = \Psi(ps_{gm,t}, ps_{gn,t}) K_{gm,gn} \sqrt{|(ps_{gm,t})^2 - (ps_{gn,t})^2|} \quad (21)$$

$$\Psi(ps_{gm,t}, ps_{gn,t}) = \begin{cases} 1 & ps_{gm,t} \geq ps_{gn,t} \\ -1 & ps_{gm,t} < ps_{gn,t} \end{cases} \quad (22)$$

$$\sum_{sup \in SPN} Vg_{sup,t} + \sum_{pg \in PGN} CH_{pg,t} - \sum_{i \in GUN} F_{i,t}^{gas} - \sum_{r \in RGN} GI_{r,t}^B = \sum_{gn \in RN} f_{gm,gn,t} \quad (23)$$

$$F_{i,t}^{gas} = \frac{a_f P_{i,t}^2 + b_f P_{i,t} + c_f q_{i,t} + STU_{i,t}^G + STD_{i,t}^G}{HHV} \quad i \in GF \quad (24)$$

$$Hg_{pg,t} = Pg_{pg,t} / P_{we} \quad (25)$$

$$CH_{pg,t} = \gamma Hg_{pg,t} + \lambda Co_{pg,t} \quad (26)$$

### F. IGDT-based scheduling model

This section presents the handling of uncertainties related to wind energy and the DR program via the IGDT method. The proposed IGDT model provides two different strategies for the system operator, including risk-averse (RA) and risk-seeker (RS) strategies.

1) *RA strategy*: This strategy is pertaining to the conditions that uncertainties of wind power and DR program have a bad effect on the objective function. So, in this strategy, the output power of the wind is lower than its predicted value and the amount of electrical load after implementation of the DR program is more than the estimated amount. The mathematical model of the RA strategy is shown as follow:

$$\max \alpha \quad (27)$$

Subject to:

$$OF \leq (1 + \sigma) OF_{BC} \quad (28)$$

$$\sum_{i \in GMM} P_{i,t} + \sum_{w \in WMM} (1 - \alpha) P_{e_{w,t}} - \sum_{pg \in PGM} P_{g_{pg,t}} - \sum_{d \in DM} (1 + \alpha) P_{s_{d,t}^A} + \sum_{d \in DM} P_{s_{d,t}^{shed}} = \sum_{n \in MM} p_{f_{mn,t}} \quad (29)$$

(2)-(15) and (19)-(26)

Where  $\alpha$  and  $\sigma$  are the uncertainty radius and percent of cost threshold, respectively. Also,  $OF_{BC}$  is the value of the objective function when the uncertain parameters are equal to their predicted values.

2) *RS strategy*: In this strategy, unlike the RA strategy, uncertainties have a desirable effect on the objective function. The mathematical model of the RS strategy is shown as follow:

$$\min \alpha \quad (30)$$

Subject to:

$$OF \leq (1 - \sigma) OF_{BC} \quad (31)$$

$$\sum_{i \in GMM} P_{i,t} + \sum_{w \in WMM} (1 + \alpha) P_{e_{w,t}} - \sum_{pg \in PGM} P_{g_{pg,t}} - \sum_{d \in DM} (1 - \alpha) P_{s_{d,t}^A} + \sum_{d \in DM} P_{s_{d,t}^{shed}} = \sum_{n \in MM} p_{f_{mn,t}} \quad (32)$$

(2)-(15) and (19)-(26)

### III. CASE STUDIES

#### A. Six-Bus network

The effectiveness of the IGDT-based scheduling model is evaluated using the 6-bus power system with the 6-node gas network as a test system. The topology of the test network is represented in Fig. 1. The electricity network has 2 GFGs, one non-GFG, one wind farm, seven branches and three loads. The gas network has two residential loads, two suppliers and five pipelines. Forecasted values of wind energy, electrical and gas loads are illustrated in Fig. 2. The gas price is equal to 1\$/kcf. Other related data are available in [9]. In PtG technology, each 1 kg of methane is obtained by combining 0.5 kg of  $H_2$  and 2.7 kg of  $CO_2$  [20]. The introduced model is performed in GAMS and solved by DICOPT.

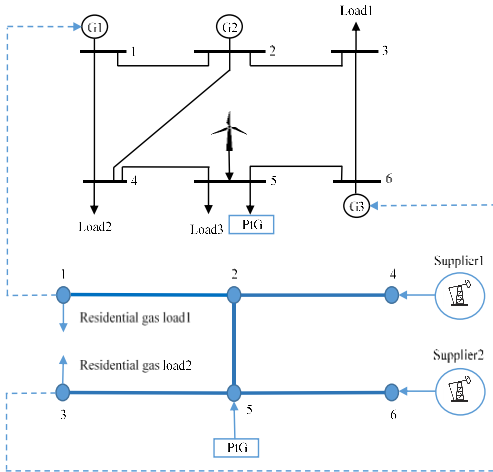

Fig. 1. Structure of the first test system.

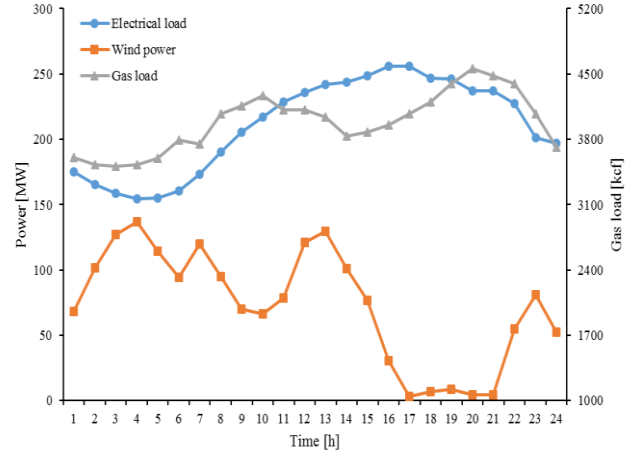

Fig. 2. Profiles of forecasted wind power, electrical and gas loads.

Four different cases are selected to analyze the performance of the IGDT-based scheduling model. These cases are as follow:

Case 1: Scheduling of electricity-gas networks without considering uncertainties, PtG and DR program.

Case 2: Integrating DR program in case 1.

Case 3: Integrating PtG technology in case 2.

Case 4: IGDT-based scheduling of case 3.

Case 1: The impact of uncertainties, PtG and DR program is not considered in this case. In Fig. 3, hourly production scheduling of generators at all hours of the day is presented. Generators in the order of the cheapest to the most expensive are: G1, G3 and G2. Unlike the G1 generator, which produces power at all hours of the day, G3 and G2 produce power in hours that electrical and residential gas demand is high. The overall cost of the power system and gas network within 24 hours is \$158937.1, in this case. Total power production of G1, G2 and G3 are 3082.9 MWh, 428.3 MWh and 140 MWh.

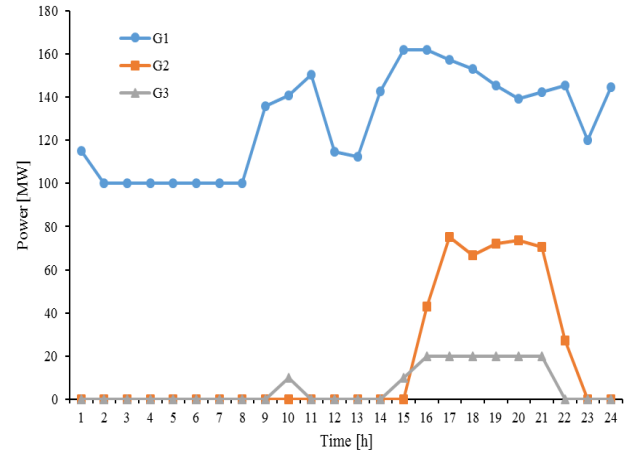

Fig. 3. The output of power units

Case 2: In this case, the impact of DR program on the scheduling of the electricity-gas networks is evaluated. The amount of electrical loads that can participate in the DR is considered 10% of the total load. Fig. 4 shows the electrical load before and after the execution of the DR program. As presented in Fig. 4, after the execution the DR program, the

electrical load is shifted from high-demand hours to low-demand hours. Compared to Case 1, the system's total cost has decreased by \$153770.4 because the total power production of the G1 generator has increased by 75.2 MWh. Total power production of G1, G2 and G3, in this case, are 3158.1MWh, 253.3 MWh and 130 MWh.

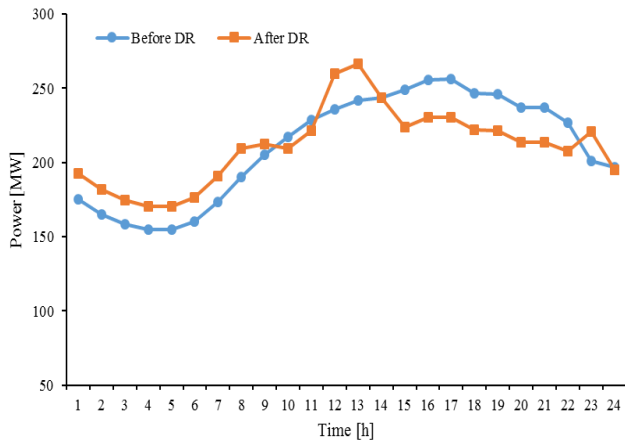

Fig. 4. Electrical load changes in DR program

Case 3: In the previous case, between 2-7 hours, 230.7 MWh of wind power has been curtailed. In order to prevent wind curtailment, in this case, PtG technology has been used. By converting curtailed wind to methane via PtG technology, the cost of the system has decreased to \$153182. Also, PtG technology has helped reduce pollutants by absorbing 24919 kg of  $CO_2$  in methanation process.

Case 4: In this case, the uncertainties of wind energy and DR program are incorporated into the scheduling model by the IGDT method. The parameter  $\sigma$  changes from 0 to 0.1 with step 0.01. Fig. 5 shows the impact of uncertainty radius changes in RA and RS strategies on operation cost. As illustrated in this figure, the operator of the system can tolerate the undesirable effects of uncertainties with higher costs. For example, for  $\alpha = 0.112$  in the RA strategy, the operation cost is \$168500.2, which is 10% more than the operation cost in the base case (case 3). It is also clear from Fig. 5 that the overall cost decreases as the uncertainty radius in the RS strategy increase.

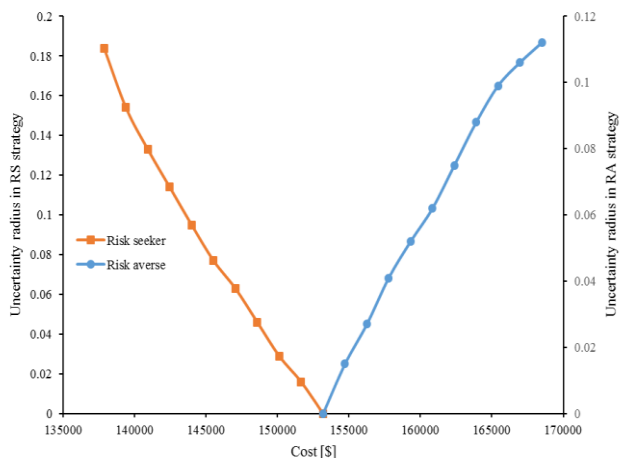

Fig. 5. Variation of the radius of uncertainty vs cost.

## B. IEEE 24-Bus Network

The modified 24-bus network with the ten-node gas system is selected in order to represent the applicability of the proposed IGDT-based model in the large system. The modified IEEE 24-bus network has 34 generators (8 GFG and 26 non-GFG), 17 electrical loads and 34 transmission lines. The gas system is joint to the power system through the 8 GFGs that are connected to 4, 6, 8, 10, 12, 15, 18 and 19 buses. In addition to the 8 GFGs, the gas network has four residential gas loads, ten pipelines and three gas wells. The schematic of the ten-node gas network is illustrated in Fig. 6. Data of power system and gas network are found in [9,21]. As well as, a wind farm and PtG unit are connected to bus 8 of the power system. The capacity of the wind farm is 700 MW.

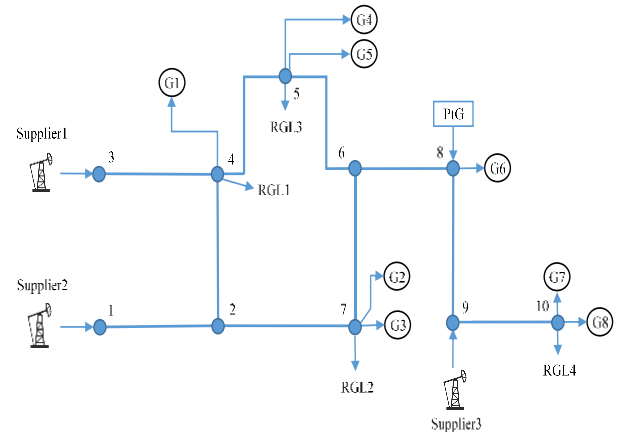

Fig. 6. Ten-node gas network.

The summary of results for cases 1-3 in this test system is provided in Table I. The results show that with the implementation DR program, the total power production of GFGs is increased and wind curtailment and total cost are decreased. As well as, the execution of the DR program prevents electrical load shedding. In addition, in case 3, all the excess wind power is absorbed by PtG technology. In this case, PtG technology absorbs 24946.7 kg of  $CO_2$  in methanation process.

In order to guarantee optimal operation of the integrated grid under the uncertainties of wind energy and DR program, the introduced IGDT-based model is used. The range of  $\sigma$  is from 0 to 0.1 with intervals equal to 0.02. The variation of cost vs the uncertainty radius is demonstrated in Fig. 7. It can be concluded that with increasing uncertainty radius, the total cost increases and decreases in RA and RS strategies, respectively.

TABLE I. THE SUMMARY OF RESULTS.

Case	Total cost (\$)	Total power production of GFGs (MW)	Wind curtailment (MW)	Electrical load shedding (MW)
1	883582.16	7754.6	353.4	13.1
2	846499.9	7811.2	231.2	-
3	845906.8	7812.5	-	-

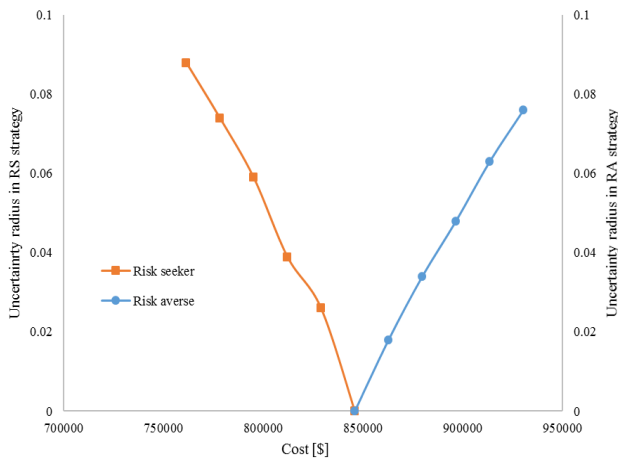

Fig. 7. Variation of the radius of uncertainty vs cost.

#### IV. CONCLUSION

In this work, an IGDT-based scheduling model is introduced to obtain the optimal operation of electricity-gas networks. DR program is implemented in the electricity system to decrease the effect of the gas network on the operation of the electricity system. The IGDT method is used to address uncertainties related to wind energy and the DR program. The proposed IGDT-based scheduling model does not need probability distribution or membership function and can provide RA and RS strategies for the system operator. The suggested model is implemented on two different networks and the results show that the DR program can decrease the impact of the gas system on the power grid. Also, from the economic and environmental viewpoint, PtG technology is a good option in the operation of two systems.

#### REFERENCES

- [1] Ning C, You F (2019) Data-driven adaptive robust unit commitment under wind power uncertainty: A Bayesian nonparametric approach. *IEEE Transactions on Power Systems* 34 (3):2409-2418
- [2] Liu C, Shahidehpour M, Fu Y, Li Z (2009) Security-constrained unit commitment with natural gas transmission constraints. *IEEE Trans Power Syst* 24 (3):1523-1536
- [3] Talebi A, Sadeghi-Yazdankhah A, Mirzaei MA, Mohammadi-Ivatloo B Co-optimization of Electricity and Natural Gas Networks Considering AC Constraints and Natural Gas Storage. In: 2018 Smart Grid Conference (SGC), 2018. IEEE, pp 1-6
- [4] Talebi A, Sadeghi-Yazdankhah A Evaluating the Impact of Fuel Switching Units and Power to Gas Technology in Co-Optimization of Electricity and Natural Gas Networks. In: 2019 International Power System Conference (PSC), 2019. IEEE, pp 542-547
- [5] Yang L, Zhao X, Li X, Feng X, Yan W (2019) An MILP-Based Optimal Power and Gas Flow in Electricity-gas Coupled Networks. *Energy Procedia* 158:6399-6404
- [6] Agabalaye-Rahvar M, Mansour-Saatloo A, Mirzaei MA, Mohammadi-Ivatloo B, Zare K, Anvari-Moghaddam A (2020) Robust Optimal Operation Strategy for a Hybrid Energy System Based on Gas-Fired Unit, Power-to-Gas Facility and Wind Power in Energy Markets. *Energies* 13 (22):6131
- [7] Li G, Zhang R, Jiang T, Chen H, Bai L, Li X (2017) Security-constrained bi-level economic dispatch model for integrated natural gas and electricity systems considering wind power and power-to-gas process. *Applied energy* 194:696-704
- [8] Talebi A, Sadeghi-Yazdankhah A Coordinated Scheduling of Hydro-Thermal-Gas Systems in the Short-Term Horizon. In: 2019 International Power System Conference (PSC), 2019. IEEE, pp 579-583
- [9] Alabdulwahab A, Abusorrah A, Zhang X, Shahidehpour M (2017) Stochastic security-constrained scheduling of coordinated electricity and natural gas infrastructures. *IEEE Systems Journal* 11 (3):1674-1683
- [10] Hemmati M, Abapour M, Mohammadi-Ivatloo B, Anvari-Moghaddam A (2021) Risk-based optimal operation of coordinated natural gas and reconfigurable electrical networks with integrated energy hubs. *IET Renewable Power Generation*:1-17
- [11] Mirzaei MA, Sadeghi-Yazdankhah A, Nazari-Heris M, Mohammadi-Ivatloo B (2019) IGDT-based robust operation of integrated electricity and natural gas networks for managing the variability of wind power. In: *Robust optimal planning and operation of electrical energy systems*. Springer, pp 131-143
- [12] Sohrabi F, Jabari F, Mohammadi-Ivatloo B, Soroudi A (2019) Coordination of interdependent natural gas and electricity systems based on information gap decision theory. *IET Generation, Transmission & Distribution* 13 (15):3362-3369
- [13] Mirzaei MA, Nazari-Heris M, Zare K, Mohammadi-Ivatloo B, Marzband M, Asadi S, Anvari-Moghaddam A (2020) Evaluating the impact of multi-carrier energy storage systems in optimal operation of integrated electricity, gas and district heating networks. *Applied Thermal Engineering* 176:115413
- [14] Bai L, Li F, Jiang T, Jia H (2017) Robust scheduling for wind integrated energy systems considering gas pipeline and power transmission N-1 contingencies. *IEEE Transactions on Power Systems* 32 (2):1582-1584
- [15] He C, Wu L, Liu T, Wei W, Wang C (2018) Co-optimization scheduling of interdependent power and gas systems with electricity and gas uncertainties. *Energy* 159:1003-1015
- [16] Deng R, Yang Z, Chow M-Y, Chen J (2015) A survey on demand response in smart grids: Mathematical models and approaches. *IEEE Transactions on Industrial Informatics* 11 (3):570-582
- [17] Su Y, Nie W, Zhou Y, Tan M, Qiao H An interval based cost-emissions optimization strategy for gas-electricity integrated energy systems under uncertainty and demand response. In: 2017 IEEE Conference on Energy Internet and Energy System Integration (EI2), 2017. IEEE, pp 1-6
- [18] Cui H, Li F, Hu Q, Bai L, Fang X (2016) Day-ahead coordinated operation of utility-scale electricity and natural gas networks considering demand response based virtual power plants. *Applied energy* 176:183-195
- [19] Mirzaei MA, Sadeghi-Yazdankhah A, Mohammadi-Ivatloo B, Marzband M, Shafie-khah M, Catalão JP (2019) Integration of emerging resources in IGDT-based robust scheduling of combined power and natural gas systems considering flexible ramping products. *Energy* 189:116195
- [20] Mehrjerdi H (2019) Optimal correlation of non-renewable and renewable generating systems for producing hydrogen and methane by power to gas process. *International Journal of Hydrogen Energy* 44 (18):9210-9219
- [21] Force R (1999) The IEEE reliability test system-1996. *IEEE Trans Power Syst* 14 (3):1010-1020