



Aalborg Universitet

AALBORG UNIVERSITY  
DENMARK

## An Open-Water Efficiency based Speed Change Strategy with Propeller Lifespan Enhancement in All-Electric Ships

Nasiri, Saman; Peyghami, Saeed; Parniani, Mostafa; Blaabjerg, Frede

*Published in:*  
IEEE Access

*DOI (link to publication from Publisher):*  
[10.1109/ACCESS.2021.3055249](https://doi.org/10.1109/ACCESS.2021.3055249)

*Creative Commons License*  
CC BY 4.0

*Publication date:*  
2021

*Document Version*  
Publisher's PDF, also known as Version of record

[Link to publication from Aalborg University](#)

*Citation for published version (APA):*

Nasiri, S., Peyghami, S., Parniani, M., & Blaabjerg, F. (2021). An Open-Water Efficiency based Speed Change Strategy with Propeller Lifespan Enhancement in All-Electric Ships. *IEEE Access*, 9, 22595 - 22604. Article 9339911. <https://doi.org/10.1109/ACCESS.2021.3055249>

### General rights

Copyright and moral rights for the publications made accessible in the public portal are retained by the authors and/or other copyright owners and it is a condition of accessing publications that users recognise and abide by the legal requirements associated with these rights.

- Users may download and print one copy of any publication from the public portal for the purpose of private study or research.
- You may not further distribute the material or use it for any profit-making activity or commercial gain
- You may freely distribute the URL identifying the publication in the public portal -

### Take down policy

If you believe that this document breaches copyright please contact us at [vbn@aub.aau.dk](mailto:vbn@aub.aau.dk) providing details, and we will remove access to the work immediately and investigate your claim.

Received December 26, 2020, accepted January 18, 2021, date of publication January 28, 2021, date of current version February 9, 2021.

Digital Object Identifier 10.1109/ACCESS.2021.3055249

# An Open-Water Efficiency Based Speed Change Strategy With Propeller Lifespan Enhancement in All-Electric Ships

**SAMAN NASIRI**<sup>1</sup>, **SAEED PEYGHAMI**<sup>2</sup>, (Member, IEEE),  
**MOSTAFA PARNIANI**<sup>1</sup>, (Senior Member, IEEE),  
**AND FREDE BLAABJERG**<sup>2</sup>, (Fellow, IEEE)

<sup>1</sup>Department of Electrical Engineering, Sharif University of Technology, Tehran 11365-11155, Iran

<sup>2</sup>Energy Technology Department, Aalborg University, 9220 Aalborg, Denmark

Corresponding author: Saeed Peyghami (sap@et.aau.dk)

This work was supported in part by the Reliable Power Electronic Based Power System (REPEPS) Project at the Department of Energy Technology, Aalborg University, as a part of the Villum Investigator Program, funded by the Villum Foundation, and in part by the Iran National Science Foundation (INSF) under Grant 98016308.

**ABSTRACT** In recent years, utilizing the electrical propulsion system in the marine industry has become widely popular. Control of the propeller has been a high-priority design challenge in this industry. One of the essential issues in propeller control is the speed control of the ships. A suitable control strategy for the propeller should be economically-efficient while ensuring stability, reliability, and power quality of the ship's power system. This article proposes an improved propeller control strategy for increasing/decreasing the ship's speed. This scheme consists of two strategies: a maximum acceleration strategy and an efficient operation strategy. The maximum acceleration strategy aims to quickly reach the final speed setpoint. On the other hand, the efficient operation strategy is deemed to increase the reliability and power quality of the ship power system, as well as having a slightly more acceleration than the conventional method. Moreover, a mechanical index is employed for comparing the performance of the various speed change strategies. By utilizing this index, which is known as loss of life (LoL), the effects of a speed change maneuver on the propeller shaft fatigue are analyzed and the advantage of the proposed method in enhancing the propeller lifespan is discussed. Simulations show that utilizing the proposed speed change scheme decreases the propeller mechanical wear and tear to about 1.8 percent of the conventional methods and consequently will increase its lifespan.

**INDEX TERMS** All-electric ships, electric propulsion system, microgrids, ship speed, loss of life, shaft fatigue.

## I. INTRODUCTION

Utilizing electrical propulsion system has gained favorable attention from the maritime industry during the last decade. It raises the ship's electric power level from a few megawatts to several tens of megawatts [1]. Combining the propulsion system with the power system has led to an integrated power system in ships. The control system of an all-electric ship (AES) can be more advanced, compared to the conventional ones. This advantage facilitates a more reliable, higher power quality, energy-efficient performance of AES during different

operational conditions [2]. Moreover, employing an electrical motor for propulsion systems with variable speed drive contributes to more reliable and cost-effective solutions for AES operation and control [3]. Besides the significant benefits offered by the integrated power system to modern ships, it has introduced new challenges for control, operation, and protection of the power system. Because of the unique dynamics of a ship propulsion system, these challenges call for new and innovative solutions. Some of these challenges were not of importance for conventional terrestrial microgrids [4]. Especially, power and energy management of the propulsion system with considering its power fluctuations is a unique challenge in a ship power system.

The associate editor coordinating the review of this manuscript and approving it for publication was Padmanabh Thakur<sup>1</sup>.

By combining the positioning and power systems, a simulator for marine vessels has been presented in [5]. Modeling of AES with low-voltage DC hybrid power systems has been discussed in [6]. Although these models subtly demonstrate load fluctuations in the power system during dynamic positioning operations, ship motions and its effects on power system during a maneuver and change of route operation have not been investigated. In addition, the main concentration of the aforementioned papers is the power system of AES and the hydrodynamic aspects of the ship during a maneuver have not been analyzed.

The propulsion system fluctuations caused by waves and in-and-out-of-water effects can have an impact on the electric power system through the electric motors and their drives [7]. As a result, they affect power quality, stability, and reliability of the ship power system. Various studies have attempted to address solutions for the consequences of these fluctuations on the voltage and frequency of the ship power grid. High-frequency fluctuations have been stated as the main cause of propulsion unit mechanical wear and tear. The in-and-out-of-water effect has also been studied and an anti-spin thruster controller has been presented in [8]. In [9], the robustness of the three common controllers for the thruster shaft has been compared: speed, torque, and power controllers. In order to mitigate the power fluctuations of the propulsion system, a hybrid energy system has been integrated into the ship power system and two energy management strategies are presented in [10].

On the other hand, an advanced energy management system is another advantage of integrating the propulsion system in the marine power system. It can lead to less fuel consumption, and hence, less greenhouse gas emission. A particle swarm optimization method and a fuzzy mechanism have been applied to the power management system of an AES in [11]. The presented optimization method aimed to minimize the operation cost and reducing greenhouse gas emissions. A distributed control agent approach for the AES energy management system has been presented in [12]. For automatic reconfiguration of the AES, a maximum flow algorithm has been used. Therefore, most of the operation action of the energy management system can be performed locally. A model predictive control (MPC) power/energy management system for the shipboard with DC-based AES has been presented in [12]. Achieving optimal power dispatch while maintaining the DC bus voltage stability is the main goal of the presented approach. A model predictive control (MPC) system for smoothing the harmonics of the AES power system has also been discussed in [13]. A power management system for AES that can function in normal/alert operation conditions has been presented in [14]. In this article, security-constrained optimal dispatch was the main concentration of the presented power management system. In [15], a load re-distribution controller for compensating frequency fluctuations of a ship power system has been studied.

An important challenge in the operation of ships is to identify an optimum speed for the ship at the operational and

design levels. In recent years, reducing greenhouse emissions and fuel consumption have brought a new perspective to this issue. Over the past few years, international organizations such as the International Maritime Organization (IMO) are emphasizing this subject and notable regulatory rules have been announced on this matter [16], [17]. An overview of the international regulations for the high-speed craft has been presented in [18].

The speed optimization studies can be categorized into two levels: design level and operational level [16]. Since the fuel consumption of a ship is related to its speed, the marine industry is working on reducing the design speed of the ships at the design level. This approach will result in reducing fuel consumption and greenhouse gas emissions within operations. For instance, Maersk's new 18,000 TEU 'Triple-E' containerhips have a design speed of 17.8 knots. It is down from the 20-26 knots range that has been the industry norm. By reducing the design speed, the containerhip will emit less greenhouse gas [19]. At the operational level, one of the important goals is slow streaming, which is reducing the operational speed of a ship to decrease fuel consumption. In some operational conditions, the speed cannot be reduced below a certain threshold and slow streaming may be inconsistent with the design speed of the ship. Thus, the ship control system must compromise between the design speed and other constraints in operational conditions such as fuel price and inventory cost of the cargo [16]. In addition, slow streaming may result in loss of revenues due to the voyage extension. The tradeoffs between voyage duration, bunker costs, and fuel-saving of ships have been discussed in [20] and three models for the explicit determination of the optimal ship speed have been suggested.

More advanced speed control can be achieved in AES with electric motor drives. By using a fixed sequence of port call and with a time window for each call, an algorithm for the speed optimization problem has been presented in [21]. The operating costs of liner ships on various routes have been estimated in [22], where a method for ship speed optimization has been presented. While the ship speed affects the voyage duration and fuel consumption, the effect of oil price on ship speed optimization has been discussed in [23]. A nonlinear speed controller for enhancing the propulsion efficiency in waves has been presented in [24].

While the previous studies have presented some interesting speed optimization solutions for the vessels, they commonly concentrated on the steady-state speed of the ship. The speed increase/decrease operational condition of the ship and its challenges have not been considered in their optimization studies. Besides, they have emphasized the mechanical and hydrodynamics engineering of the ship. Nevertheless, the speed change impacts on the power system and the related electrical constraints have been ignored in the previous studies. In other words, the propulsion system dynamics and the interactions between the power system and propulsion system have not been considered thoroughly during the ship speed change. As electric propulsion is the connection point

where various fields like the mechanics, hydrodynamics, and electric engineering studies meet, speed optimization in both the design and the operation levels should be carried out by considering the mentioned fields in an integrated model.

Considering the aforementioned issues and challenges, this article proposes a strategy for speed change of the AES.

This proposed method optimizes the open-water efficiency of the propeller during a speed change maneuver.

For analyzing the effects of this method on the ship power system, the propeller, the electric power system, and their interconnections in a notional ship have been modeled thoroughly. Employing the proposed strategy decreases the propeller torque variation during speed change operation. Consequently, the frequency and voltage fluctuations of the ship power system will be decreased and the power quality of the power system will be increased. Besides, the proposed method does not affect the voyage distance during a time period. Thus, it will not result in the loss of revenues due to the voyage extension. In addition, a mechanical index for comparing different strategies of a ship speed change is introduced in this article. Although this index has been employed in mechanical literature for analyzing the failure rate of materials for designing the propeller at the design level, so far it has not been used in electrical state-of-arts for comparing different strategies of operational maneuvers. This index concerns the wear and tear of the propeller shaft and by employing it, speed change strategies can be compared considering the lifespan of the propeller shaft.

In the following, an integrated model for analyzing the speed change strategies of a ship is presented in section II. More details on the power system and hydrodynamic parts of the model have also been presented in this section. In section III an index for comparing operational methods during a ship speed change scenario is introduced. This index calculates fatigue damage of the propeller during an operational condition. By employing that, the wear and tear of the propeller are taken into account in the optimization of the ship operation. The proposed algorithm for controlling the ship speed during a speed change maneuver is presented in section IV. A mariner class vessel is simulated in section V using the presented model. Then, the proposed algorithm for speed increase/decrease is analyzed in this section and the advantages of the proposed method compared to the conventional ones are discussed. Finally, the outcomes of the analysis and the novelty of this article are summarized in section VI.

## II. INTEGRATED MODEL FOR ALL-ELECTRIC SHIP

In this section, an integrated AES model for analyzing ship speed change strategies is presented. A ship control system is responsible for defining the propeller speed reference to lead the ship to its desired speed.

The ship's acceleration/deceleration depends on its motion model, associated with the propeller speed. The propeller shaft is connected to an electric motor and a motor drive controls its speed to attain the ship's operational goals.

Besides, the speed or torque of the propeller follows its unique dynamic characteristics [25]. A framework for this integrated model for the ship speed change analysis is shown in figure 1. In the integrated model, connections between the electrical, mechanical, and hydrodynamic phenomena of a ship motion have been considered. The model consists of three main parts: the power system model, the ship model, and the control system. In addition, the ship model has been divided into two parts: the propeller model and the ship motion model. Individual parts of this model framework will be discussed in the following.

### A. SHIP CONTROL

In a speed change scenario, the operator defines a reference for the speed of the ship. In the control system, the speed of the ship is being monitored. When the operator tends to change the ship speed, the speed of the propeller should be adjusted (or regulated) based on the propeller and the ship characteristics [25], [26]. According to the propeller's desired speed, the motor drive will change its stator current in order to reach the desired RPM (Round Per Minute). The produced thrust of the propeller, which is related to the propeller characteristics, will result in acceleration/deceleration of the ship according to the ship's motion condition.

### B. SHIP POWER SYSTEM

A single line diagram of a notional ship power system is shown in figure 2 [27], [28].

The major power consumer in a ship power system is the propulsion system, which has its unique dynamic characteristics. Without losing generality, other shiploads have been considered as hotel loads (such as lighting, ventilation, heating, and freshwater generation) and base loads. The main bus voltage is 4.16kV/60Hz. Two types of power generators have been considered in the power system, including gas turbine and diesel generator. Since the gas turbine generator efficiency is more than the diesel generator, it produces a major part of electrical power in the ship power system. In contrast, the diesel generator's startup time is lower. Thus, they can come in handy in some operational scenarios.

In this study, the gas turbine generator of the notional power system in figure 2 is a 36-MVA round rotor generator. In addition, a 4-MVA salient pole diesel generator is included in the power system. Field voltages of these generators are controlled by an AC1A type excitation system. This exciter model is a field-controlled generator excitation system with non-controlled rectifiers [29], [30]. In addition, a common dynamic model for the gas turbine governor has been used in this study. It includes speed control and temperature control loop [31]. The propulsion system has a 20 MVA asynchronous motor, which is connected to a 12-pulse F.O.C (Field-Oriented Control) drive. This motor drive orients the stator current according to the rotor flux for attaining an orthogonal spatial angle between the armature magnetomotive force (MMF) and the field flux. Thus, the flux and torque can be controlled independently [32].

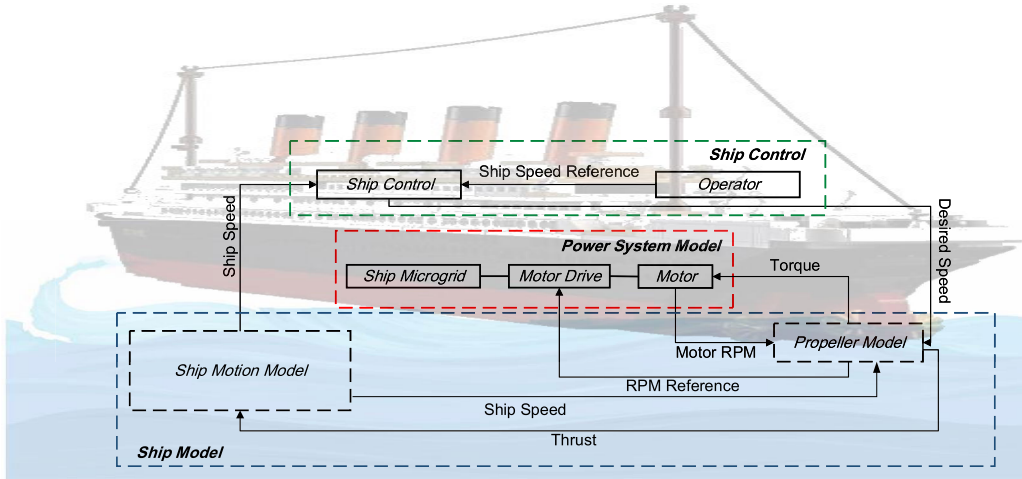

FIGURE 1. Integrated model for ship speed change analysis.

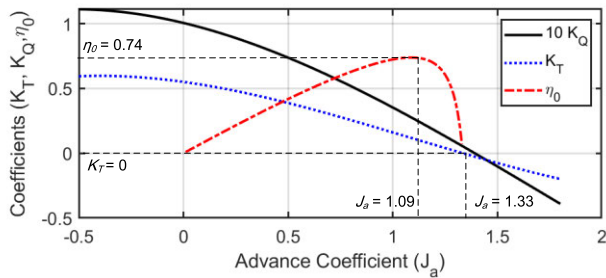

FIGURE 2.  $K_T$ ,  $K_Q$  and  $\eta_0$  for the propeller given in Table 1.

C. PROPELLER MODEL

Two non-dimensional terms are usually used to depict the performance of a propeller: (1) Thrust coefficient ( $K_T$ ), and (2) Torque coefficient ( $K_Q$ ). They are associated with the geometrical configuration of the propeller and are obtained by open-water tests on propellers [33].

Force and torque produced by a propeller can be calculated as:

$$T = K_T \rho n^2 D^4 \tag{1}$$

$$Q = K_Q \rho n^2 D^5 \tag{2}$$

where  $D$  is the diameter of the propeller,  $n$  is the rotational speed,  $\rho$  is the water density,  $T$  is the thrust produced by the propeller, and  $Q$  is the torque of the propeller. Furthermore, these non-dimensional coefficients are related to other hydrodynamic parameters, given as [34]:

$$K_T = f_k(R_n, J_A, \frac{P}{D}, \frac{A_E}{A_o}, z, \frac{t}{c}) \tag{3}$$

$$K_Q = f_Q(R_n, J_A, \frac{P}{D}, \frac{A_E}{A_o}, z, \frac{t}{c}) \tag{4}$$

where  $P/D$  is the pitch diameter ratio,  $z$  is the number of propeller blades,  $A_E/A_o$  is the blade area,  $R_n$  is Reynold's number,  $t/c$  is the ratio of the maximum propeller blade thickness to the length of the cord at a characteristic radius,

and  $J_A$  is the advance coefficient that can be determined by the velocity of advance ( $V_a$ ) by using (5).

$$J_A = \frac{V_a}{nD} \tag{5}$$

The velocity of advance,  $V_a$  is the speed at which water is passing through the disc of the propeller. For a straightforward study, it can be approximately assumed to be equal to the ship speed. But, if the propeller is placed behind the ship hull and for more precision, the ship motion effects such as wake fraction can be taken into account. For this study and without loss of generality, the velocity of advance has been assumed to be equal to the speed of the ship.

An essential coefficient, which is going to be used in the proposed strategy for speed changing of the ship, is called open-water efficiency of the propeller,  $\eta_0$ .

It is defined as the ratio between the required power to rotate the propeller and the thrust power. The latter is the product of the thrust and the ship speed [35].

For a deeply submerged propeller, the propeller efficiency can be calculated according to propeller characteristics [36].

$$\eta_0 = \frac{V_a T_a}{2\pi n Q_a} = \frac{V_a K_T}{2\pi n K_Q D} = \frac{J_a K_T}{2\pi K_Q} \tag{6}$$

Multiple regression analyses have been applied to Wageningen B-series propeller open-water characteristic data from [34] and  $K_T$  and  $K_Q$  with respect to  $J_a$  have been extracted.  $K_T$ ,  $K_Q$ , and  $\eta_0$  curves are shown in figure 3.

The parameters of the propeller used for drawing this figure are given in Table 1. As it can be seen in figure 3, when  $J_a$  is equal to 1.33, the ship has reached its steady-state and final speed.

Thus,  $K_T$  and its acceleration will become zero. In reality, there is a deviation from zero for coping with the ship and wind resistance. Furthermore, the propeller reaches its maximum efficiency when  $J_a$  is 1.09. It means that at this point the ratio of produced to consumed power is at its highest efficient

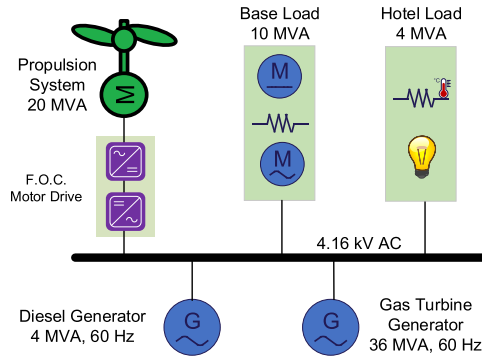

FIGURE 3. Notional ship power system with two different generators.

TABLE 1. Propeller Properties.

Symbol	Value
$P/D$	1.25
$A_E/A_o$	0.65
$Z$	4
$D$	5.6 m
$\rho$	997 kg/m <sup>3</sup>

state. Considering that the efficiency of the propeller speed is the core idea in this article, the proposed speed change strategy will use  $\eta_0$  to find an efficient state for the propeller during the ship operational conditions. More details about considering this important matter in the proposed algorithm are discussed in section IV.

#### D. THRUST MODELLING

The thrust of the propeller will result in acceleration of the ship and can be used in ship dynamic analysis. Change of the velocity with a produced thrust can be calculated by using (7) [24].

$$m\dot{U} = R(u) + T(1 - t_d) \quad (7)$$

where  $m$  is the total mass including the ship mass and added mass like cargo,  $U$  is ship velocity and  $t_d$  is thrust deduction due to hull resistance.  $R(u)$  is the total resistance of the ship while moving forward. It contains various components. Common resistances, which are usually being considered, are wave-making resistance, wind resistance, various wave spectrum disturbances, and frictional resistance [26].

#### III. FATIGUE DAMAGE DUE TO SPEED CHANGE

Life prediction of components such as the propeller shaft plays an important role in the design and operation levels of a vessel. This analysis depends on the cumulative fatigue damage of the components [37]. Some important impacts that can cause shaft fatigue failure are wear and tear of the propeller shaft, corrosion effects, overloads, stress concentration, and impact loads, all of which reduce the fatigue strength of shafts [38]. When the propeller torque changes during a maneuver, fatigue damage increases in its shaft in a cumulative manner, which may lead to a fracture of the

shaft. Although this matter is crucial in the reliability of a ship operational method and affects the maintenance cost of the ship, it has not been taken into account in state-of-the-arts for finding optimized operational methods. In the following, a proper index for comparing operational methods with respect to their effects on the wear and tear of the propeller will be proposed.

In 1945, Miner presented a mathematical form for the linear rule of fatigue damage [39], [40]. The number of cycles to failure (NCF) caused by torque  $\tau$  is an index that can be used for calculating the mechanical fatigue of the shaft. NCF for ASTM 293/2-3 class materials, which is commonly used as shafts, can be calculated as follows [41]:

$$NCF = 0.5(6.4 \times 10^{-6} \times \frac{\tau}{R})^{-17.68} \quad (8)$$

where  $R$  is the shaft radius and  $\tau$  is the applied torque to the shaft. To quantify the impact of mechanical oscillations on the shaft lifespan, the Miner's mathematical expression can be used [39], [42].

$$LoL = \sum_{i=1}^k \frac{n_i}{NCF_i} \quad (9)$$

where  $LoL$  is loss of life duration of the shaft,  $n_i$  is the number of cycles the torque  $\tau$  is applied to the shaft and  $k$  is the number of power oscillation cycles.

The  $LoL$  index is a number between zero and one. When it reaches one during a time period, it means that the shaft is completely damaged. During the lifespan of a shaft, this aggregated index will increase according to the applied torque to the shaft until it reaches its final value and the shaft is damaged. According to this index, one can identify the method which has lower fatigue damage on the propeller for speed changing of a ship. Any method that has lower  $LoL$  during a simulation time period has a lower effect on the shaft fatigue.

In this study, this index has been used for comparison of the proposed methods with the conventional ones. For this purpose, the aggregated  $1/NCF$  during the simulation time is calculated using (9).

The result will indicate the  $LoL$  index. Considering the propeller shaft lifespan in searching for the optimized methods of speed changing will result in a more economically-efficient operation of the vessels.

#### IV. THE PROPOSED EFFICIENT SPEED CHANGE STRATEGY

In the state-of-the-art ship speed optimization studies, the propeller efficient operation during a ship speed change maneuver has not been considered.

The optimization goals presented in the literature are focused on finding the optimum speed for the ship to convey in steady-state operational conditions [16], [23], [24]. Conventionally, for increasing/decreasing the ship speed, the desired propeller speed will be calculated according to the desired ship speed [25], [26]. Considering  $V_a$  equal to the

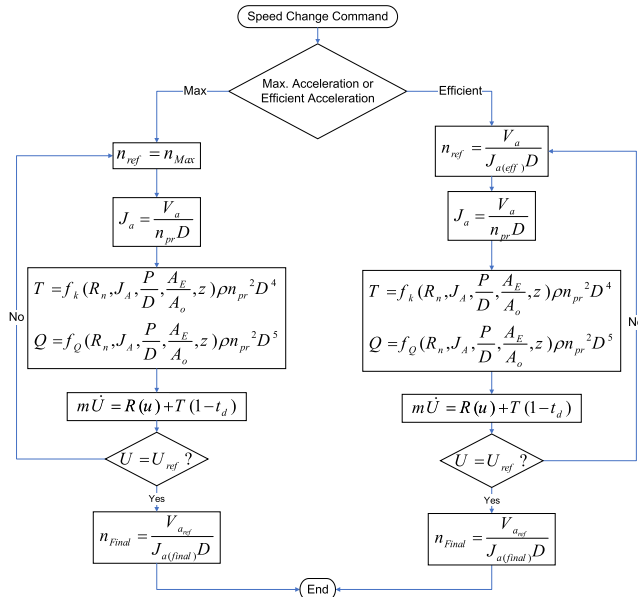

FIGURE 4. Proposed speed change algorithm.

desired ship speed and  $J_a$  equal to the amount at which the propeller thrust is zero, the desired propeller speed can be determined by (5).

In this section, two new strategies for changing the ship speed are proposed: (1) the maximum acceleration strategy (MAS), and (2) the efficient acceleration strategy (EAS). The functional algorithm for these strategies is presented in figure 4. In this algorithm,  $n_{max}$  is the maximum speed at which the propeller motor can work,  $n_{ref}$  is the propeller speed reference determined by the ship control system,  $n_{final}$  is the speed of the propeller at the desired speed of the ship, and  $n_{pr}$  is the speed of the propeller at the actual ship speed in the operational condition. Moreover,  $J_{a(final)}$  is the advance coefficient in the desired speed,  $J_{a(eff)}$  is the advance coefficient when the propeller has the highest efficiency,  $U$  is the actual speed of the ship, and  $U_{ref}$  is the desired speed of the ship.

When the ship operator decides to change its speed, the ship control system can reach the new speed with two different strategies: MAS or EAS. In MAS, the propeller speed will deploy its maximum stable speed by the propeller motor drive. This will produce the full thrust and according to (7), the ship will have the highest acceleration. When the ship reaches its desired speed, the propeller speed will be fixed by the motor drive. Thus, at this state, the ship acceleration will become zero. In EAS, the ship control system should monitor the ship speed. According to (6) and considering the actual speed of the ship, the speed of the propeller for the highest efficient operation can be calculated. Then as the speed rises, the new propeller speed is calculated and sent to the motor drive control. These two strategies are simulated in the next section. In addition, their results are discussed and compared with the conventional methods of increasing/decreasing the ship speed.

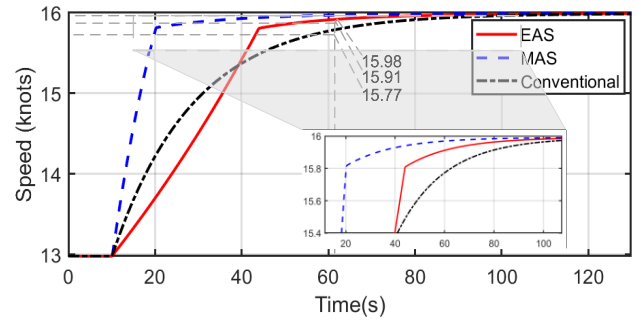

FIGURE 5. Speed of the ship during an acceleration from 13 knots to 16 knots using different strategies of MAS, EAS and conventional.

V. SIMULATION RESULTS

Considering the integrated model framework shown in figure 1 and the concepts presented in the second section, the ship model has been simulated in Simulink/MATLAB. A notional mariner vessel with a total mass of 48 kilotons and a length of 160 meters is assumed [43]. Considering the power system model, which consists of a converter for the propeller motor drive, the step time of the simulation has been set to 60  $\mu$ s. For this study, one of the regular operations of a vessel [28] has been discussed. Ship speed increase/decrease, which is a common operational maneuver during a vessel journey, has been studied using the proposed algorithm and power system fluctuations during this operational condition has been extracted.

It is assumed that the operator tends to increase the ship speed from 13 knots by about 23 percent to 16 knots. For simplicity and without losing generality, wave resistance and wake fraction have been neglected in this scenario. Figure 5 depicts the speed of the ship during this scenario. As expected, the MAS has the highest speed acceleration compared to other strategies, and it reaches the final speed faster. Besides, it can be seen that after 60 seconds of the simulation, the EAS speed surpasses the conventional method.

Figure 6 shows the actual propeller speed during this maneuver. In the MAS, the propeller speed reference reaches the maximum possible level and the actual propeller speed follows that. In the conventional method, the propeller speed reaches the steady-state value corresponding to the desired speed of the ship. In the proposed efficient strategy, the speed of the propeller increases in a manner in which the advance velocity will be kept at its efficient amount.

The advance velocity of the ship during the scenario has been shown in figure 7. The  $J_a$  coefficient in the efficient strategy has been kept equal to 1.09 during the scenario, which is the efficient level for propeller operation according to figure 3. However, in the other methods, the  $J_a$  coefficient has exceeded this amount while the propeller speed increases.

Before investigating the advantages of the proposed EAS on the ship power system, the distance that the ship has been voyaged and the energy consumed by the propeller during the time has been depicted in figure 8 and figure 9, respectively. For a better comparison, the consumed energy has been normalized according to MAS. In the maximum

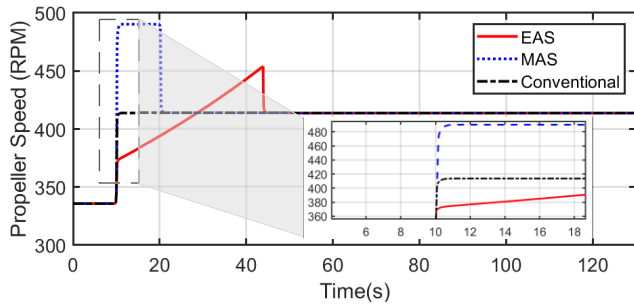

**FIGURE 6.** Actual and reference speeds of the propeller during an acceleration from 13 knots to 16 knots using different strategies of MAS, EAS and conventional.

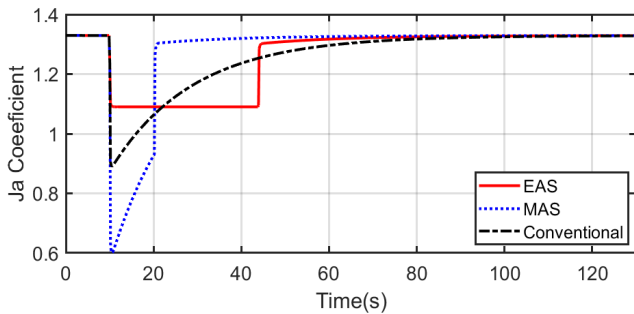

**FIGURE 7.** The advance coefficient of the propeller during an acceleration from 13 knots to 16 knots using different strategies of MAS, EAS and conventional.

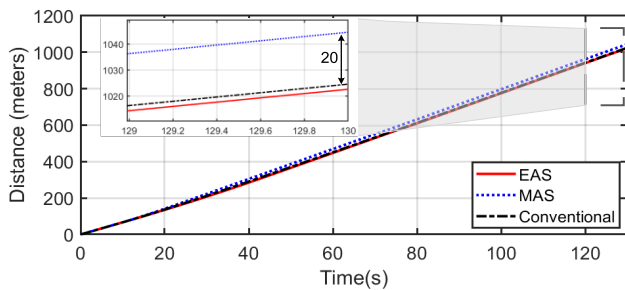

**FIGURE 8.** Voyage distance of the ship during an acceleration from 13 knots to 16 knots using different strategies of MAS, EAS and conventional.

acceleration method, the route distance at the end of the simulation is 20 meters more than the two other strategies, which is negligible. Similarly, the consumed energy in this strategy is slightly more than two other strategies, which is also negligible. It means that while the energy consumption and the traveled distance is almost equal in these strategies, the efficient strategy has the advantages which will be discussed in the following.

Figure 10 and figure 11 show the voltage and frequency fluctuations of the ship power system during the speed increasing scenario. As shown in figure 10, the least voltage drop during the maneuver belongs to EAS. The voltage drop in this strategy is just 0.2 percent. This is about half of the conventional method voltage drop, which is 0.42 percent. This low voltage drop demonstrates better power quality

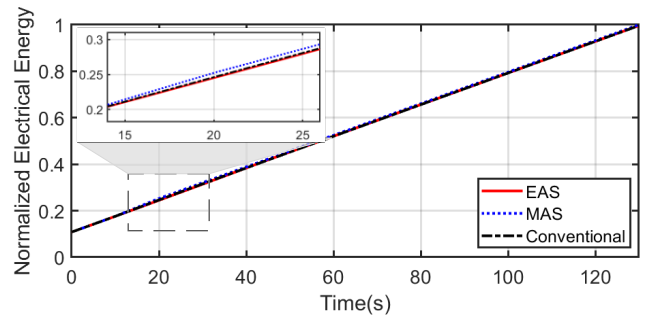

**FIGURE 9.** Normalized consumed electrical energy of the propeller during an acceleration from 13 knots to 16 knots using different strategies of MAS, EAS and conventional.

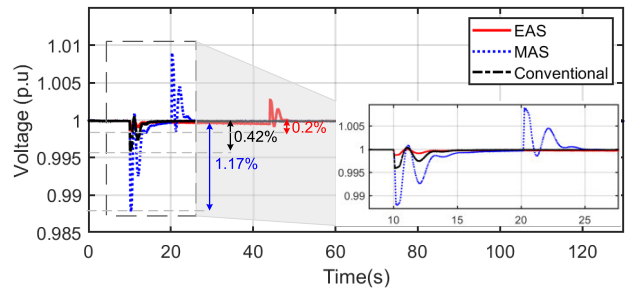

**FIGURE 10.** Voltage of the ship power system during an acceleration from 13 knots to 16 knots using different strategies of MAS, EAS and conventional.

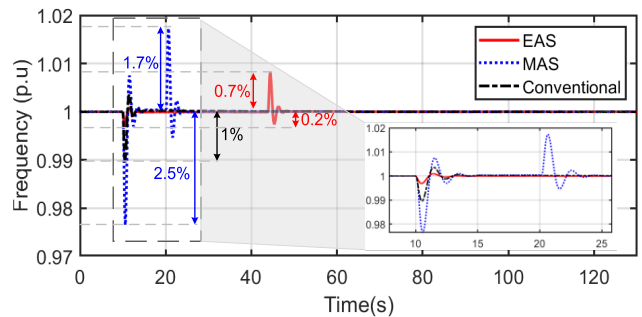

**FIGURE 11.** Frequency of the ship power system during an acceleration from 13 knots to 16 knots using different strategies of MAS, EAS and conventional.

during vessel voyage, as well as improving the power system stability during extreme operational conditions. The MAS has the highest voltage drop, which is about 1.2%. Frequency fluctuation during the scenario is also lower in the EAS. The conventional method and MAS have 1% and 2.5% frequency drop, respectively.

However, the frequency drop in EAS is 0.2 percent. Although the frequency increases with 0.7% at the EAS when the ship reaches its desired speed, it has 80 percent less frequency drop than the conventional method. It will result in enhanced reliability and power quality of the power system in extreme conditions.

In addition, sensitive equipment such as computers, which are sensitive to frequency drop, will operate more reliable



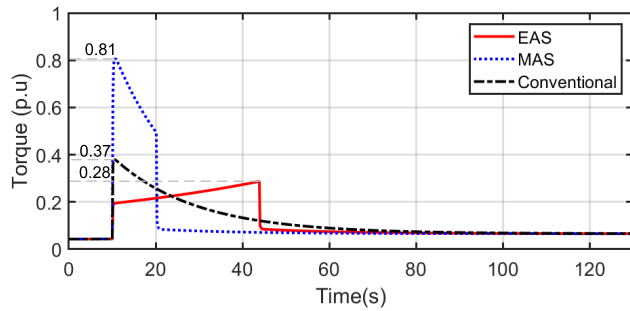

**FIGURE 12.** Torque of the propeller during an acceleration from 13 knots to 16 knots using different strategies of MAS, EAS and conventional.

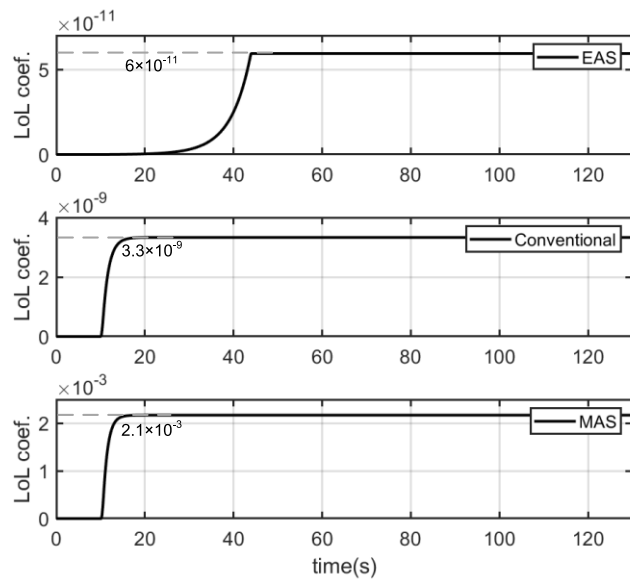

**FIGURE 13.** Loss of life duration of the shaft during an acceleration from 13 knots to 16 knots using different strategies of MAS, EAS and conventional.

utilizing the proposed EAS. In other words, the EAS results in better functionality of the ship power system during the ship speed change, while the ship acceleration is not lowered in comparison with the conventional method. On contrary, the ship acceleration has been increased fairly at some points. Figure 12 shows the propeller torque fluctuations during the speed change maneuver. While the maximum acceleration strategy has the highest torque fluctuations, which rises to 0.8 p.u. during the speed increase, the EAS has the least torque fluctuations. For EAS the torque rises to 0.28 p.u. at most. This torque increase is about 25% less than the conventional method, which is 0.37 p.u. One of the most important advantages of decreasing torque fluctuations is to yield a much longer shaft life duration.

For comparing fatigue damage to the shaft in the investigated methods, the LoL index introduced in section III is employed. Figure 13 shows the loss of life duration of the shaft for the speed change maneuver with the discussed methods. As mentioned in section IV, the LoL index can show the fatigue damage of a material during a torque fluctuation experience. Lower LoL in an operational strategy shows that

**TABLE 2.** Summary of the Methods Effectiveness.

Parameter	Conventional	EAS	MAS
<i>Voltage drop</i>	0.42%	0.2%	1.17%
<i>Frequency drop</i>	1%	0.2%	2.5%
<i>Torque rise</i>	0.36 p.u	0.27 p.u	0.8 p.u
<i>Loss of Life</i>	$3.3 \times 10^{-9}$	$6 \times 10^{-11}$	$2.1 \times 10^{-3}$

utilizing that approach can result in a longer lifespan of the shaft. As it can be seen in figure 13, the proposed EAS has the lowest LoL index. It is 1.8 percent of the conventional method. It means that by utilizing the proposed method, the propeller shaft can survive from fatigue damage 55 times more than the conventional method.

Notably, the propeller shaft experiences other fluctuations such as wave encounter effects during its operation time. But as far as speed changing operation affects its lifetime, the proposed method will increase its lifespan 55 times more than the conventional method. The MAS has the highest fatigue damage on the propeller shaft, which is about 6000 percent more than the conventional method. It means that although this method will result in a rapid acceleration in the ship speed, this method has a massive fatigue impact on the shaft. Thus, it should only be used in necessary operational conditions such as fleeing from danger. For a better perspective of the proposed methods effectiveness, Table 2 summarizes the performance indexes and analysis data of the proposed and conventional methods.

**VI. CONCLUSION**

This article has proposed a novel strategy for increasing/decreasing the speed of all-electric ships. The proposed algorithm consists of two strategies: one of them leads to maximum possible acceleration for the ship, while the other one prioritizes open-water efficiency and lifespan of the propeller operation. For investigating these methods, an interconnected ship motion and power system model comprising the related equations and concepts has been presented. In addition, an index for comparing the ship operational methods with respect to the propeller shaft lifetime has been employed. This index, which is called loss of life (LoL) of the shaft, can identify which operational method leads to less fatigue damage on the ship shaft. Employing the operational strategies with consideration of LoL will decrease wear and tear of the shaft and consequently decrease downtimes and maintenance costs.

Using the aforementioned interconnected model and the lifetime index, the proposed speed change strategies have been compared with the conventional method. It was shown that utilizing the efficient strategy will result in more power quality of the ship power system during a speed change maneuver. Besides, the proposed efficient method will reduce the fatigue damage of the propeller shaft drastically in comparison with the conventional method. This will result in reducing the operational and maintenance costs and

downtimes of the ship. On the other hand, using the maximum acceleration method will make the ship rapidly reach its desired speed. For future works, the proposed strategies will be used to improve the power management system in all-electric ships.

## REFERENCES

- [1] A. Ouroua, L. Domaschk, and J. H. Beno, "Electric ship power system integration analyses through modeling and simulation," in *Proc. IEEE Electr. Ship Technol. Symp.*, Jul. 2005, pp. 70–74.
- [2] G. Seenumani, J. Sun, and H. Peng, "Real-time power management of integrated power systems in all electric ships leveraging multi time scale property," *IEEE Trans. Control Syst. Technol.*, vol. 20, no. 1, pp. 232–240, Jan. 2012.
- [3] A. K. Ådnanes, *Maritime Electrical Installations and Diesel Electric Propulsion*. Zürich, Switzerland: ABB AS, Mar. 2003.
- [4] A. Monti, S. D'Arco, L. Gao, and R. A. Dougal, "Energy storage management as key issue in control of power systems in future all electric ships," in *Proc. Int. Symp. Power Electron., Electr. Drives, Autom. Motion*, Jun. 2008, pp. 580–585.
- [5] T. I. Bø, A. R. Dahl, T. A. Johansen, E. Mathiesen, M. R. Miyazaki, E. Pedersen, R. Skjetne, A. J. Sørensen, L. Thorat, and K. K. Yum, "Marine vessel and power plant system simulator," *IEEE Access*, vol. 3, pp. 2065–2079, 2015.
- [6] N. Zohrabi, J. Shi, and S. Abdelwahed, "An overview of design specifications and requirements for the MVDC shipboard power system," *Int. J. Electr. Power Energy Syst.*, vol. 104, pp. 680–693, Jan. 2019.
- [7] J. Hou, J. Sun, and H. Hofmann, "Adaptive model predictive control with propulsion load estimation and prediction for all-electric ship energy management," *Energy*, vol. 150, pp. 877–889, May 2018.
- [8] O. N. Smogeli and A. J. Sørensen, "Antispin thruster control for ships," *IEEE Trans. Control Syst. Technol.*, vol. 17, no. 6, pp. 1362–1375, Nov. 2009.
- [9] A. J. Sørensen and Ø. N. Smogeli, "Torque and power control of electrically driven marine propellers," *Control Eng. Pract.*, vol. 17, no. 9, pp. 1053–1064, Sep. 2009.
- [10] J. Hou, J. Sun, and H. F. Hofmann, "Mitigating power fluctuations in electric ship propulsion with hybrid energy storage system: Design and analysis," *IEEE J. Ocean. Eng.*, vol. 43, no. 1, pp. 93–107, Jan. 2018.
- [11] F. D. Kanellos, A. Anvari-Moghaddam, and J. M. Guerrero, "A cost-effective and emission-aware power management system for ships with integrated full electric propulsion," *Electr. Power Syst. Res.*, vol. 150, pp. 63–75, Sep. 2017.
- [12] A. Feliachi, K. Schoder, S. Ganesh, and H. J. Lai, "Distributed control agents approach to energy management in electric shipboard power systems," in *Proc. IEEE Power Eng. Soc. Gen. Meeting, PES*, Jun. 2006, pp. 1–6.
- [13] E. Skjong, J. A. Suul, A. Rygg, T. A. Johansen, and M. Molinas, "System-wide harmonic mitigation in a diesel-electric ship by model predictive control," *IEEE Trans. Ind. Electron.*, vol. 63, no. 7, pp. 4008–4019, Jul. 2016.
- [14] S. Mashayekh and K. L. Butler-Purry, "An integrated security-constrained model-based dynamic power management approach for isolated microgrids in all-electric ships," *IEEE Trans. Power Syst.*, vol. 30, no. 6, pp. 2934–2945, Nov. 2015.
- [15] D. Radan, A. J. Sørensen, A. K. Ådnanes, and T. A. Johansen, "Reducing power load fluctuations on ships using power redistribution control," *SNAME J. Marine Technol.*, vol. 45, no. 3, pp. 162–174, 2008.
- [16] H. N. Psarafitis and C. A. Kontovas, "Ship speed optimization: Concepts, models and combined speed-routing scenarios," *Transp. Res. C*, vol. 44, no. 4, pp. 52–69, 2014.
- [17] Ø. Buhaug, J. J. Corbett, Ø. Endresen, V. Eyring, J. Faber, S. Hanayama, D. S. Lee, D. Lee, H. Lindstad, A. Z. Markowska, A. Mjelde, D. Nelissen, J. Nilsen, C. Pålsson, J. J. Winebrake, W.-Q. Wu, and K. Yoshida, *Second IMO Greenhouse Gas Study 2009*. London, U.K.: International Maritime Organization, 2009.
- [18] H. Hoppe, "International regulations for high-speed craft," in *Proc. FAST 8th Int. Conf. Fast Sea Transp.*, 2005, pp. 1–7.
- [19] H. N. Psarafitis, *Sustainable Shipping: A Cross-Disciplinary View*. New York, NY, USA: Springer, 2019.
- [20] D. Ronen, "The effect of oil price on the optimal speed of ships," *J. Oper. Res. Soc.*, vol. 33, no. 11, pp. 1035–1040, Nov. 1982.
- [21] L. M. Hvattum, I. Norstad, K. Fagerholt, and G. Laporte, "Analysis of an exact algorithm for the vessel speed optimization problem," *Networks*, vol. 62, no. 2, pp. 132–135, Sep. 2013.
- [22] A. N. Perakis and D. I. Jaramillo, "Fleet deployment optimization for liner shipping part 1. Background, problem formulation and solution approaches," *Maritime Policy Manage.*, vol. 18, no. 3, pp. 183–200, Jan. 1991.
- [23] D. Ronen, "The effect of oil price on containership speed and fleet size," *J. Oper. Res. Soc.*, vol. 62, no. 1, pp. 211–216, Jan. 2011.
- [24] M. Blanke, L. Pivano, and T. A. Johansen, "An efficiency optimizing shaft speed control for ships in moderate seas," in *IFAC Proceedings Volumes*, vol. 7, no. 1, pp. 329–336, 2007.
- [25] T. I. Fossen, *Handbook of Marine Craft Hydrodynamics and Motion Control*. Chichester, U.K.: Wiley, 2014.
- [26] T. Perez, *Ship Motion Control: Course Keeping and Roll Reduction Using Rudder and Fins*. London, U.K.: Springer-Verlag, 2005.
- [27] A. K. Ådnanes, *Maritime Electrical Installations and Diesel Electric Propulsion*. Oslo, Norway: ABB Marine AS, 2003.
- [28] S. S. Kalsi and O. Nayak, "Ship electrical system simulation," in *Proc. IEEE Electr. Ship Technol. Symp.*, Jul. 2005, pp. 63–69.
- [29] *IEEE Recommended Practice for Excitation System Models for Power System Stability Studies*, Standard 421.5-2016, Revision of IEEE Std 421.5-2005IEEE, 2016.
- [30] P. S. Kundur, *Power System Stability and Control*. New York, NY, USA: McGraw-Hill, 2009.
- [31] P. Mahat, Z. Chen, and B. Bak-Jensen, "Gas turbine control for islanding operation of distribution systems," in *Proc. IEEE Power Energy Soc. Gen. Meeting*, Jul. 2009, pp. 1–7.
- [32] B. K. Bose, *Power Electronics and Variable Frequency Drives: Technology and Applications*. Hoboken, NJ, USA: Wiley, 1996.
- [33] S. Donnarumma, M. Figari, M. Martelli, S. Vignolo, and M. Viviani, "Design and validation of dynamic positioning for marine systems: A case study," *IEEE J. Ocean. Eng.*, vol. 43, no. 3, pp. 677–688, Jul. 2018.
- [34] M. Bernitsas, D. Ray, and P. Kinley, *KT, KQ and Efficiency Curves for Wageningen B-Series*. Ann Arbor, MI, USA: Univ. Michigan, May 1981.
- [35] O. Gur, "Maximum propeller efficiency estimation," *J. Aircr.*, vol. 51, no. 6, pp. 2035–2038, 2014.
- [36] O. N. Smogeli, E. Ruth, and A. J. Sørensen, "Experimental validation of power and torque thruster control," in *Proc. IEEE Int. Symp., Mediterrean Conf. Control Autom. Intell. Control*, Jun. 2005, pp. 1506–1511.
- [37] A. Fatemi and L. Yang, "Cumulative fatigue damage and life prediction theories: A survey of the state of the art for homogeneous materials," *Int. J. Fatigue*, vol. 20, no. 1, pp. 9–34, Jan. 1998.
- [38] G. Vizentin, G. Vukelić, and M. Srok, "Common Failures of Ship Propulsion Shafts," *Pomorstvo*, vol. 31, no. 2, pp. 85–90, 2017.
- [39] M. A. Miner, "Cumulative damage in fatigue," *J. Appl. Mech.*, vol. 12, no. 3, pp. 159–164, 1945.
- [40] D. R. Askeland, P. P. Fulay, and D. K. Bhattacharya, *Essentials of Materials Science & Engineering—SI Version*. Boston, MA, USA: Cengage Learning, 2009.
- [41] S. M. N. R. Abadi, M. Davarpanah, M. Mahmoodi, S. Nasiri, and R. Bekhradian, "Multiobjective optimal DERs placement and sizing considering generator shaft fatigue," *IEEE Trans. Power Syst.*, vol. 33, no. 6, pp. 6787–6794, Nov. 2018.
- [42] M. C. Jackson, S. D. Umans, R. D. Dunlop, S. H. Horowitz, and A. C. Parikh, "Turbine-generator shaft torques and fatigue: Part I—Simulation methods and fatigue analysis," *IEEE Trans. Power App. Syst.*, vol. PAS-98, no. 6, pp. 2299–2307, Nov. 1979.
- [43] M. S. Chislett and J. Strom-Tejsen, "Planar motion mechanism tests and full-scale steering and manoeuvring predictions for a mariner class vessel," *Int. Shipbuilding Prog.*, vol. 12, no. 129, pp. 201–224, May 1965.



**SAMAN NASIRI** received the B.Sc. and M.Sc. degrees in electrical engineering from the University of Tehran (UT), Tehran, Iran, in 2014 and 2016, respectively. He is currently pursuing the Ph.D. degree with the Sharif University of Technology (SUT), Tehran. He was a Visiting Ph.D. Scholar with the Department of Energy Technology, Aalborg University, Denmark, in 2020. His research interests include power system control, dynamics, and power management in all-electric ships.



**SAEED PEYGHAMI** (Member, IEEE) received the B.Sc., M.Sc., and Ph.D. degrees in electrical engineering from the Department of Electrical Engineering, Sharif University of Technology, Tehran, Iran, in 2010, 2012, and 2017, respectively. From 2015 to 2016, he was a Visiting Ph.D. Scholar with the Department of Energy Technology, Aalborg University, Aalborg, Denmark, where he was a Postdoctoral Researcher. In 2019, he was a Visiting Researcher with Intelligent Electric Power Grids, Delft University of Technology, Delft, The Netherlands. He is currently an Assistant Professor in electrical power engineering with Aalborg University. His research interests include reliability, control, and stability of power electronic-based power systems, and renewable energies.



**MOSTAFA PARNIANI** (Senior Member, IEEE) received the B.Sc. degree in electrical power engineering from the Amirkabir University of Technology, Iran, in 1987, the M.Sc. degree in electrical power engineering from SUT in 1990, and the Ph.D. degree in electrical engineering from the University of Toronto, Canada, in 1995. From 1988 to 1990, he was with Ghods-Niroo Consulting Engineers Company, and also with the Electric Power Research Center (EPRC), Tehran. He was a Visiting Scholar with the Rensselaer Polytechnic Institute, USA, from 2005 to 2006. He is currently a Professor of electrical engineering with the Sharif University of Technology (SUT), Tehran, Iran. His research interests include power system dynamics and control, applications of power electronics in power systems, and renewable energies. He has been a member of several national committees and councils in his field, and is the Chair of the IEEE Iran Section Power Chapter.



**FREDE BLAABJERG** (Fellow, IEEE) received the Ph.D. degree in electrical engineering from Aalborg University in 1995. He was with ABB-Scandia, Randers, Denmark, from 1987 to 1988. He became an Assistant Professor in 1992, an Associate Professor in 1996, and a Full Professor of power electronics and drives in 1998. Since 2017, he has been a Villum Investigator. He is honoris causa at University Politehnica Timisoara (UPT), Romania, and Tallinn Technical University (TTU), Estonia. He has published more than 600 journal articles in the fields of power electronics and its applications. He has coauthored four monographs and editor of ten books in power electronics and its applications. His current research interests include power electronics and its applications such as in wind turbines, PV systems, reliability, harmonics, and adjustable speed drives. He received the 33 IEEE Prize Paper Awards, the IEEE PELS Distinguished Service Award, in 2009, the EPE-PEMC Council Award, in 2010, the IEEE William E. Newell Power Electronics Award 2014, the Villum Kann Rasmussen Research Award 2014, the Global Energy Prize in 2019, and the 2020 IEEE Edison Medal. He was the Editor-in-Chief of the IEEE TRANSACTIONS ON POWER ELECTRONICS, from 2006 to 2012. He has been Distinguished Lecturer of the IEEE Power Electronics Society, from 2005 to 2007, and for the IEEE Industry Applications Society, from 2010 to 2011 and 2017 to 2018. From 2019 to 2020, he served as the President for the IEEE Power Electronics Society. He has been the Vice President of the Danish Academy of Technical Sciences. He is nominated in 2014-2020 by Thomson Reuters to be between the most 250 cited researchers in Engineering in the world.

...