



AALBORG UNIVERSITY
DENMARK

Aalborg Universitet

Stability and Failure Mode

Olesen, Frits Bolonius; Poulsen, Annemarie

Published in:
Nordic Workshop Eurocodes part 10, Structural Fire Design

Publication date:
1992

Document Version
Early version, also known as pre-print

[Link to publication from Aalborg University](#)

Citation for published version (APA):
Olesen, F. B., & Poulsen, A. (1992). Stability and Failure Mode. In *Nordic Workshop Eurocodes part 10, Structural Fire Design: Eurocodes part 10, Structural Fire Design* (pp. 7-8). Dansk Ingeniørforening, DIF..

General rights

Copyright and moral rights for the publications made accessible in the public portal are retained by the authors and/or other copyright owners and it is a condition of accessing publications that users recognise and abide by the legal requirements associated with these rights.

- Users may download and print one copy of any publication from the public portal for the purpose of private study or research.
- You may not further distribute the material or use it for any profit-making activity or commercial gain
- You may freely distribute the URL identifying the publication in the public portal -

Take down policy

If you believe that this document breaches copyright please contact us at vbn@aub.aau.dk providing details, and we will remove access to the work immediately and investigate your claim.

Normsekretariatet
Ingeniørhuset
Vester Farimagsgade 29
1780 København V

Telefon 33 15 65 65
Telefax 33 83 71 71
Telegram DIngeniør
Giro 8 02 56 65

Nordic Workshop

Eurocodes part 10, Structural Fire Design

Copenhagen, 5th and 6th February 1992

Minutes

Normsekretariatet
Ingeniørhuset
Vester Farimagsgade 29
1780 København V

Telefon 33 15 65 65
Telefax 33 83 71 71
Telegram DIngenior
Giro 9 02 56 85

2. Participants

Nordic Workshop - Eurocodes part 10 Date 5 + 6/2-92

Name	Re: Eurocode	Company and address	Phone/fax
Ove Pettersson	3	LTH, Box 118, S-22100 Lund, Sweden	+46 46 107361/ +46 46 104612
Annemarie Poulsen	2	Rockwool Insulation Holding, DK-2640 Hedehusene	+45-160300/ +45-164911
Erik Aasheim	5	Norsk Treteknisk Institutt, Postboks 113 Blindern, N-0314 Oslo	+47 2 965671/ +47 2 604291
Nils Forsén	4	Norges Byggeforskningsinstitutt, Postboks 123, Blindern, N-0314 Oslo	+47 2 965583/ +47 2 965542
Per Jahren	2	BMB-Brannvernsamarbejdet Mur og Betong, Postboks 53, Blindern, 0313 Oslo	+47 2 965860/ +47 2 564238
Harald Landrø	5	SINTEF NBL - Norges branntekniske laboratorium, N 7034, Trondheim	+47 7 595190/ +47 7 595168
Thore Hagberg	3	Norges Byggstandardiseringsråd, Forskningsveien 3 B, Blindern, N-0315 Oslo	+47 2 965950/ +47 2 608570
Bjørn Aasen	3	Stålgruppen, Postboks 7072 - Homannsbyen, N-0301 Oslo	+47 2 465820/ +47 2 461838
P.J. Knudsen	4	BIRCH & KROGBOE A/S, Rådgivende Ingeniører, Tekniker-byen 34, DK-2830 Virum	+45-858585/ +45-858595
Frits Bolonius Olesen	1,5	Aalborg University, Sohngårdsholmsvej 57, DK-9000 Aalborg	+45-1542116637 +45-148243
Jürgen König	5	Tråtek, Box 5609, S-114 86 Stockholm	+46 8 145300/ +46 8 116188
Yngve Anderberg	2	Fire Safety Design, Science Park Ideon, S-223 70 Lund, Sweden	+46 46 182270/ +46 46 182275
Bent-Erik Carlsen		Rockwool Insulation Holding, DK-2640 Hedehusene	+45-160300/ +45-161525
Peter M.Thorup	3	Esben Kirkegaard A/S, Trørødvej 74, DK-2950 Vedbæk	+45-891922/ +45-892472
Tapio Leino		Technical Research Center of Finland, Lab. of Structural Engineering, PL 26,SF-02151 ESBO, Finland	+358 0 4566683/ +358 0 4567003
Anja Nylund	3	Ministry of the Environment, PL 399, SF-00121 Helsinki, Finland	+358 0 1605686/ +358 0 1605541
Jaakko Huuhtanen	5	Ministry of the Environment, PL 399, SF-00121 Helsinki, Finland	+358 0 1605683/ +358 0 1605541
Jarmo Majamaa	5	VTT, Fire Technology Laboratory, PL 109, Espoo 02151, Finland	+358 0 4561792/ +358 0 4564815
Ulla-Maija Jumppanin	2	VTT, Fire Technology Laboratory, PL 109, Espoo 02151, Finland	+358 0 4564792/ +358 0 4564815
Pentti Loikkanen	4	VTT, Fire Technology Laboratory, PL 109, Espoo 02151, Finland	+358 0 4564800/ +358 0 4564815
Jörgen Thor	3	Stålbyggnadsutveckling/Brandskyddslaget, V.Henriksborg-sv. 10, 13131 Nacka, Sweden	+46 8 6414665/ +46 8 7020666
Ulf Wickström	1,4	SP, Box 857, S-502 61, Borås	+46 33 165194/ +46 33 117759
Sven Thelandersson	3	Dep. of Structural Engineering, Lund University, Box 118, S-22100 Lund, Sweden	+46 46 107368/ +46 46 10 4212
Freddy Madsen (Secretary)		Baltica, Klausdalsbrovej 601, DK-2750 Ballerup	+45-875302/ +45-875221

Contents

1. Programme	Page	1
2. Participants	Page	3
3. 1st Session, Chairman Sven Thelandersson LTH, (S) General information	Page	4
Background for the Eurocodes, Bent-Erik Carlsen, DIF (DK)	Page	4
Introduction to Eurocodes and the Safety Philosophy behind the Codes, Niels Krebs Ovesen, DIF (DK). A Brief Summary	Page	5
EC 1 Actions, Sven Thelandersson LTH (S)	Page	5
4. 2nd Session, Chairman Harald Landrø, SINTEF-NBL (N)	Page	5
EC 1 Actions, Ulf Wickstrøm SP (S)	Page	5
5. 3rd Session, Chairman Pentti Loikkanen, VTT (SF)	Page	7
Stability and Failure Mode, Annemarie Poulsen and Frits Bolonius Olesen, DIF (DK)	Page	7
6. 4th Session, Chairman Bent-Erik Carlsen, DIF (DK)	Page	8
EC 6 Masonry, Ulla Maija Jumppanen, VTT (SF)	Page	8
7. Summary of Group Discussions (EC 1 - EC 6)	Page	9
8. Summary, Resolutions, and Future Work	Page	12
Appendix A: Available national comments		
Appendix B: The EC-system		
Appendix C: Project teams		

Thursday 6th.

- 08,30 3rd session. Chairman Pentti Loikkanen, VTT, (SF)
Deformations, stability and other failure mode, Frits Bolonius Olesen,
Annemarie Poulsen, DIF (DK)
- 10,00 Coffee / Tea
- 10,30 Discussion in groups continued
- 12,30 Lunch
- 14,00 4th session. Chaiman Bent-Erik Carlsen, DIF (DK)
EC6 mansonry, Ulla-Maija Jumppanen, VTT (SF)
- 15,00 Coffee / Tea
- 15,30 Summary, resolutions, further work
- 17,00 Closure of the seminar

Annemarie Poulsen

Nordic Workshop on Eurocodes Part 10, Structural Fire Design.

Copenhagen 1992-02-05/06 * Programme.

Hotel Globetrotter, Engvej 171, DK-2300 Copenhagen S.

Wednesday 5th.

- | | |
|-------|---|
| 09,00 | Registration |
| 09,30 | Welcome, Bent-Erik Carlsen, DIF (DK) |
| 09,40 | <u>1st. session. Chairman Sven Thelandersson, LTH (S)</u>

Introduction to Eurocodes and the safety philosophy behind the codes,
Niels Krebs Ovesen, NS (DK) |
| 11,00 | EC1 Actions, Ulf Wickström, SP (S)

Discussion |
| 12,30 | Lunch |
| 14,00 | <u>2nd. session. Chairman Harald Landrø, SINTEF-NBL. (N)</u>

Discussion continued |
| 15,00 | Coffee / Tea |
| 15,30 | Discussion in groups of the national comments on EC2 Concrete, EC3
steel, EC4 Composite and EC5 Timber |
| 17,30 | Closure of 1th day |
| 19,30 | Dinner at a restaurant in Copenhagen |

3. 1st Session, Chairman Sven Thelandersson, LTH (S)

General Information and Scope of the Workshop

The aim of the workshop was to discuss the draft of part 10 in EC 1 - EC 6 and to search for common Nordic comments on the drafts. Furthermore, to discuss how the Nordic countries in the best way can forward their comments so as to influence the future work in this field.

The national comments on the EC 1 - EC 6 were either sent to the participants before the meeting or distributed during the meeting. Appendix A gives an overview of the national comments. If you are missing some of the national comments please contact the workshop secretary, Freddy Madsen.

During the workshop discussions it was mentioned that a mandate for the development of a Eurocode on aluminium is on its way.

Background for the Eurocodes, Bent-Erik Carlsen, DIF (DK)

BEC gave a brief review of the historical development of the eurocodes. The organisation behind the eurocode work is shown in appendix B. The mandate from the EEC to CEN is essential. It describes the need for eurocodes. The work is financed by the Commission. The mandate is given to CEN and not to a Technical Committee (TC). TC 127 is dealing with "Hot Data" and TC 250 with the Eurocodes. The organization, as shown in appendix B, is constantly changing. For the time being working groups (WG 1 and WG 2) are being reorganized.

Introduction to Eurocodes and the Safety Philosophy behind the Codes, Niels Krebs Ovesen, DIF (DK). A brief summary.

The four basic components of the safety philosophy are

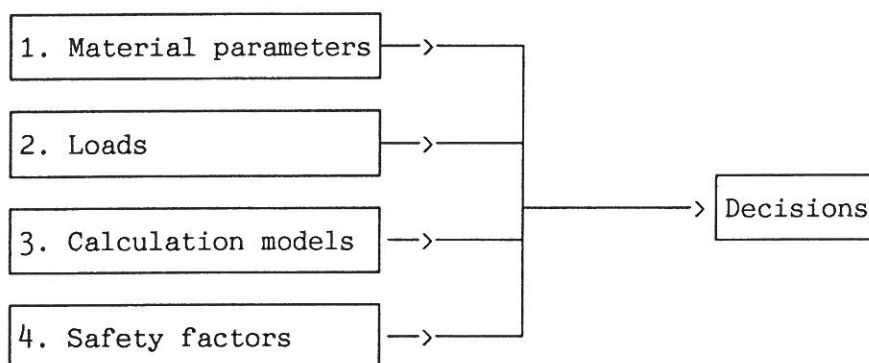

The four components are of equal importance and have to be introduced in a code. Safety factors are often embedded in calculation models.

Safety margins are the gap between the ultimate limit state and the serviceability limit state.

The ultimate limit state is characterized by severe structural damage.

The serviceability limit state is characterized by loss of serviceability.

A code should specify the ultimate limit state, the serviceability state, and the design situation (load, material parameters, and calculation models).

A good code should concentrate on functional requirements and less on calculation models.

A modern code should :

- Be simple in use.
- Give the opportunity to use alternative applications in order to allow deviations and progress of the profession.
- Take past experience of the profession into account.

EC 1 Actions, Sven Thelandersson LTH (S).

Sven Thelandersson : "Safety Considerations and Calibration of the Fire Design Rules in the Eurocodes with Fire Testing."

This paper was presented in connection with the Swedish comments on Eurocode 3, part 10, which were distributed to the participants at the Nordic workshop. Below the main points in Thelandersson's paper are listed together with his additional comments, given at the meeting.

- The proposed design principles for steel structures seem to be well adapted to the level of safety in earlier practice. The critical temperature for steel is a little lower according to EC 3 than earlier practice (590 °C contra 530 °C).
- As the critical temperature varies with the relation between the permanent and the variable load, the results from fire testing should specify the strength and the related actual degree of loading.
- There is a need for performance criteria for insulation materials.
- Consistence between tests and calculations is needed.

In connection with the above, Ulf Wickstrøm mentioned a telefax from Niels Erik Andersen, Dansk Brandteknisk Institut. NEA's main points were:

- There will be no need for fire testing if testing can be replaced "monkey-calculations".
- Some information can only be derived from testing.

In the following discussion it was pointed out that

- Both fire testing and fire calculations are needed in the future development of the structural fire research.
- Calculations are based on test results.
- Especially testing of some structural elements such as joints, etc. is needed.

4. 2nd Session, Chairman Harald Landrø, SINTEF-NBL (N).

Continuing the 1st session:

EC 1 Actions, Ulf Wickstrøm SP (S).

UW is a member of SC1/PT9 Actions.

In a new draft of EC 1 part 20, Actions on Structures Exposed to Fire, the introduction of three set's of thermal loads is expected

- 1) The ISO 834-curve, the hydrocarbon-curve, and a smouldering fire curve.

Normalsekretariatet
Ingeniørhuset
Vester Farimagsgade 29
1780 København V

Telefon 33 15 65 65
Telefax 33 93 71 71
Telegram Dfingenior
Giro 9 02 56 85

- 6 -

- 2) Time-temperature curves like the opening factor curves or the similar gamma time-temperature curve developed as an analytical description, based on modified time concept of the opening factor curves.
- 3) Time-temperature curves gained from field modelling or zone modelling (energy balance methods).

The next draft is likely to deal only with items 1 and 2 above, and item 3 is postponed to a later edition of the code.

There was a discussion about time-temperature curves gained by energy balanced methods and the meaning of the expression "energy balance method". No clear definition was given but the expressions listed below were made during the following presentation of the national comments on the EC 1:

1. Norway and Denmark expressed the opinion that there was too much focus on the traditional time-temperature curve. Appropriate general fire models should have priority and from these models simplifications can be derived.
2. The time-temperature curve should be based on risk assessment and fire scenarios (Norway).
3. A hydrocarbon-curve should be introduced (Norway).
4. Protection materials might be damaged by explosions, which have to be taken into account in some cases (Norway).
5. The top level should be a calculated time-temperature exposure as a result of an energy balance in the fire compartment (Denmark).
6. The Swedish comments were included in UW's presentation of the three set's of thermal loads.
7. Finland had no comments on EC 1.
8. The emissivity factor was discussed. The factor is 0.5 in the draft. UW suggested a factor of 1.0 until better results are given. Yngve Anderberg was of the opinion that 0.5 is a reasonable factor. Denmark would like the value to be documented.

For additional information, please see the national comments.

Ulf Wickstrøm gave a brief summary of the ongoing work concerning actual temperatures in the European test furnaces.

When comparing European furnaces you find that although you try to establish the standard time-temperature curve, there is a great variation in the actual time-temperatures in different furnaces. This is mainly due to differences in geometry and temperature measurements at tiny spots. It is suggested that the temperature is measured with plate-thermometers instead.

5. 3rd Session, Chairman Pentti Loikkanen, VTT (SF).

Stability and Failure Mode, Annemarie Poulsen and Frits Bolonius Olesen, DIF (DK)

As an introduction to the day's work in the four groups AMP and FBO gave some examples on failure modes.

Example 1 The elongation of steel elements in a structure can lead to failure mode in other elements for instance fire separation walls. It was pointed out that there is a difference in the elongation in TC 127 drafts $E_s = 1.5\%$ of the EC 3, where $E_s = 2\%$ which corresponds to a difference in allowed bending $L/\bar{15}$ and $L/20$ respectively.

Example 2 Finger joints in glulam beams give rise to a considerably reduced loadbearing capacity due to the increased charring in vicinity of the joints. In spite of this fact finger joints have been neglected in the fire-design rules of the codes in use so far.

Example 3 Creep effects at high temperatures (100-300°C) in timber structures seem to have a much greater influence on the deformation properties than noticed so far. For this reason the design rules especially for columns in most countries are on the unsafe side.

Example 4 The spalling effect of concrete structures during fire is well known and occurs in almost all fire tests and real fires. In spite of this, practically no fire-design rules take spalling effects into consideration.

The examples were given to stress that:

1. In the future eurocode work it should be remembered that during a fire the structures might influence other structural members and possibly influence the spread of fire although the load-bearing member itself can resist the fire.
2. In the future eurocode work we should pay more attention to problems and phenomena which have so far been neglected in the fire-design rules and practice in spite of their significant influence on the structural behaviour in the fire situation.

The examples led to a discussion. The main points and questions were:

1. The secondary effects from the load-bearing structures on other structural elements, i.e. fire separating structures, should be taken into account.
2. Is the scope of the eurocode primarily Life Safety or is there other elements such as loss of property etc., that have to be taken into account. Will such considerations lead to non-economical structures in an overall economic view (building costs contra loss due to fires) ?.

3. The $E_s = 2\%$ for steel, might be convenient if the engineer deals with specific problems that might occur in connection with secondary effects on fire separating elements etc.
4. The steel stress-strain curve (2%) in EC 3 gives rise to different opinions. Some express the opinion that the curve gives results which are similar to the testing results of today. Some express the opinion that the elongation will influence the stability of other components in the building.

6. 4th Session, Chairman Bent-Erik Carlsen DIF (DK)

EC 6 Masonry, Ulla Maija Jumppanen, VTT (SF)

The draft for EC 6 is best characterized as a framework or a layout for a eurocode. It is not acceptable as a Eurocode draft. A new draft is expected in May 1992, until then time is wasted discussing the code.

At the workshop the general opinion was that discussions of the code should be postponed until a new edition is available.

The following remarks were given on the work and the possibilities of influencing the code:

- Spalling is also a problem for masonry, the code ought to deal with it.
- In Finland a project about different kinds of bricks and their behaviour in the fire situation, is about to start. The results from these test's could be valuable for the work, but due to the time schedule for the work it seems impossible to incorporate the results in the first edition of the code.
- Finland wants information on what kind of bricks the other Nordic countries would like to have tested.
The question leads to a discussion of the need for a code on masonry. In most countries the masonry structures are generally accepted in the legislation without fire testing. You could say that legislation is built on centuries' experience. In the next years, however, new types of bricks are expected and therefore the need for a code will be stronger in the coming years.

7. Summary of group discussions

EC 1 Actions

The code was discussed in plenum, as discribed previously.

EC 2 Concrete

The members of the group are shown in the list of participants.
The group agreed on the following comments:

- 1) The code is too comprehensive and must be reduced considerably in size.
- 2) The code is a mixture between a textbook and a handbook.
E.g. : - Design examples should be placed in the annex.
- Existing examples should be evaluated as a seperate textbook.
- 3) The code is too little in favour of concrete, e.g. table 5.1, the stress reduction is far too conservative.
- 4) In principle there should not be several sets of material data.
- 5) In principle the code should be prepared in this order:
 - a) General functional requirements, and data for general calculations.
 - b) Simple design method based on the 500 °C isotherm.
 - c) Simple design based on tables.
- 6) Tables, in particular for columns, must be verified.
- 7) The code should be dealing with spalling e.g. by adding the following sentence: " For very dense and wet concrete, control should be made of the destructive structural effects of spalling".
- 8) The risk of bond failure must be mentioned in the code.

In the following discussion it was mentioned that:

- The code is preliminary and that nothing seems to have happened in the period from the Luxembourg meeting in 1989 until the draft in April 1990.
- There is a need for simple design methods such as tables. The tables must be non-mandatory but easy to get hold of. Where they should be placed is an editorial matter.

EC 3 Steel

The members of the group are shown in the list of participants.
The group has the following comments:

- 1) The group agrees with the general comment made by the "EC 2 - group".

2) Technical comments

Design method:

Cross-section class 1 : Plastic global analysis

Cross-section class 2 : Only member design

Cross-section class 3 : Critical temp. = 450 °C was discussed

Cross-section class 4 : Critical temp. = 350 °C was discussed

Verification : $R_{d,f} \geq E_{d,f}$ should be redefined such that

$$\eta = \gamma_M \frac{E_{d,f}}{R}$$

$$\gamma = \begin{cases} \gamma_{M0} = 1,10 \\ \gamma_{M1} = 1,10 \\ \gamma_{M2} = 1,15 \end{cases}$$

Table 3.1 : The group, except DK, agrees with the strain limit of 2 %. However functional requirements should be emphasized. Structural behaviour in fires should prevent fire spread, ensure evacuation and fire brigade and support fire fighting.

The kappa factor :

The value of 0.70 should probably be 0.85. An informal appendix should give guidelines on how to make alternative calculations. The designer should also be aware of the functional consequences of a low kappa value.

The kappa factor was discussed, the general opinion was that a critical approach to the factor, more research, and a better documentation are needed.

EC 4 Composite

The members of the group are shown in the list of participants. The group has the following comments:

- 1) Consistency between EC 2,3 and 4 is needed.
- 2) Explanations for the boxed values are needed
- 3) References for evaluation of the theories applied are needed.
- 4) The background for the simple models should be available.
- 5) The 30 min. statement is not acceptable as a general statement.
- 6) The absolute value for the length of column should be replaced by the slenderness ratio.
- 7) The code should be independent of manufacturers' interest. The group is of the opinion that the simple models in the code are incorrect.

EC 5 Timber

The members of the group are shown in the list of participants.

Two of the participants in the group, Jürgen Köning (S) and Jarmo Majmää (SF), are members of project team SC5/PT10 (EC timber/fire), from which was referred that the work in the project team is planned to proceed as follows:

October 1991: 1. meeting
January 1992: 1. draft
March 1992 : 2. meeting
March 1992 : 2. draft
October 1992: Final draft

The 1. draft was discussed in the group and commented preliminarily at the following 6 points:

- * The layout of the draft (has been improved considerably compared with the ECC-draft from April 1990, but should be shortened furthermore if possible).
- * More natural fire based design rules (in stead of standard-fire design rules).
- * Charring rate and depth (more general rules e.g. as proposed in the DK-comments).
- * Strength and stiffness properties (more complete rules, including creep effects if possible).
- * Finger joints (should be taken into account if possible).
- * Mechanical joints (not standard-test based empirical rules only).

8. Summary, resolutions and future work.

There was a general agreement that the eurocodes need to be :

- 1) **Concise** : Clearly divided into requirement - recommendation - subsidiary support.
- 2) **Consistent** : It is essential that there is consistency within, and between the various eurocodes. (E.g. same parameters and values.
- 3) **Provable** : The codes should be based on science and experience, which are generally accepted and published.
- 4) **Independent**: Independent of manufactures.

That is always not the case in the drafts to-day.

In order to influence the work with eurocodes and make the codes acceptable to the Nordic countries the workshop agreed on :

- 1) When part 10 is discussed in SCs it is of vital importance that our points of view are put forward to the SCs by people who have the necessary knowledge on fire and are present at the meetings.
- 2) In the PTs, where there is no Nordic representation we should seek informal contacts.
- 3) The list of participants in this workshop includes the Nordic national contact for each eurocode part 10, for exchange of information and coordination.
- 4) A second workshop will be arranged when needed. The four national contacts for the work with eurocode part 10 will take the initiative.
- 5) No single Nordic comment on the eurocodes is made but the national contacts will see to it that the national comments are distributed among the Nordic countries in order to combine and coordinate our efforts.
- 6) A national horizontal group for fire is, or is about to be, formed in all the Nordic countries. Contact between these groups will be made when established.

APPENDIX A

*Available written national comment at the Nordic Workshop,
 February the 5th and 6th 1992*

	<i>Sweden</i>	<i>Finland</i>	<i>Norway</i>	<i>Denmark</i>
<i>EC 1</i>	X	XX	XX	X
<i>EC 2</i>	XX	X		X
<i>EC 3</i>	X	X		X
<i>EC 4</i>		X		X
<i>EC 5</i>	XX			X
<i>EC 6</i>				

- Eurocode 1 - Actions*
- Eurocode 2 - Concrete*
- Eurocode 3 - Steel*
- Eurocode 4 - Composite*
- Eurocode 5 - Timber*
- Eurocode 6 - Masonry*

THE EC-SYSTEM

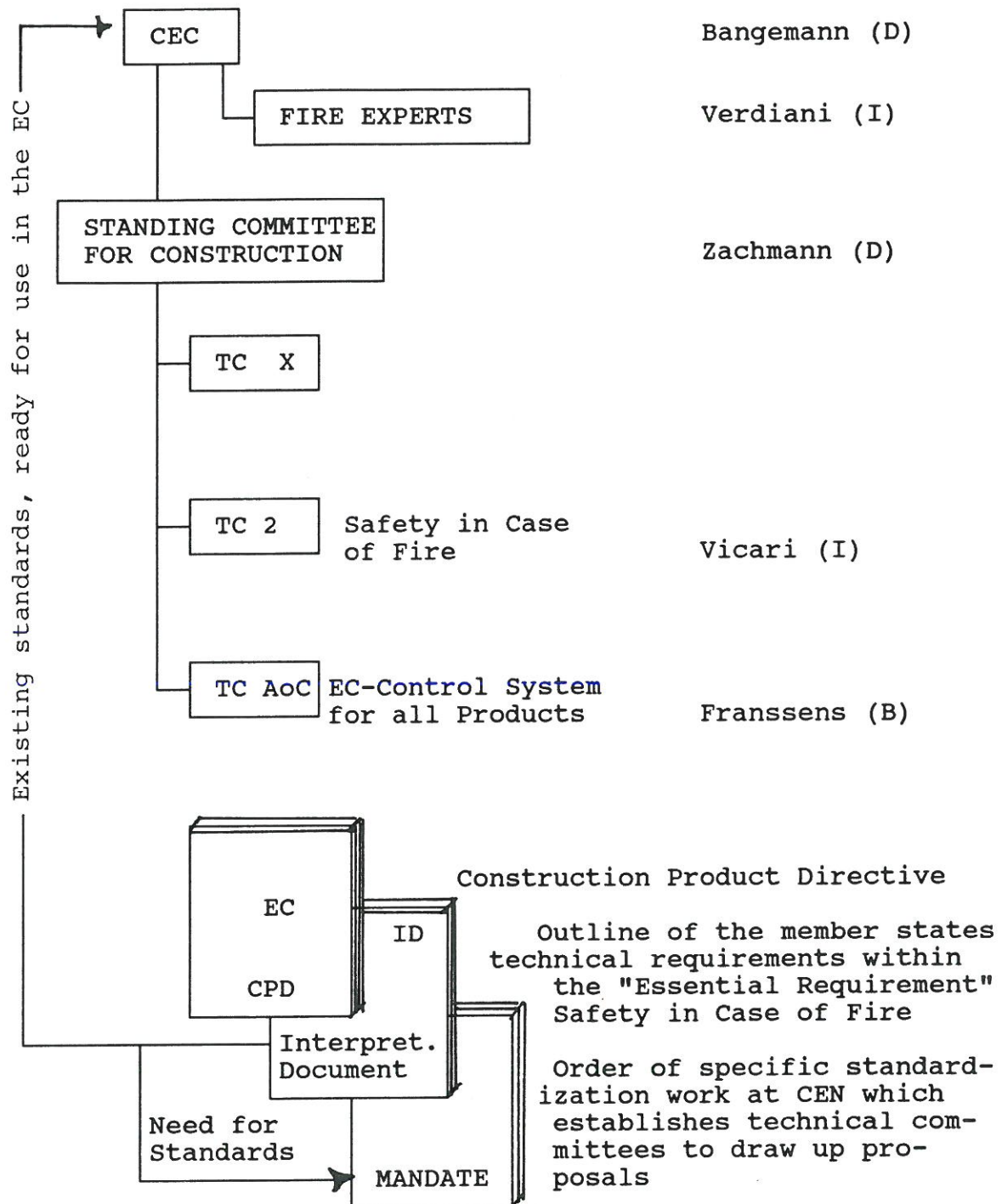

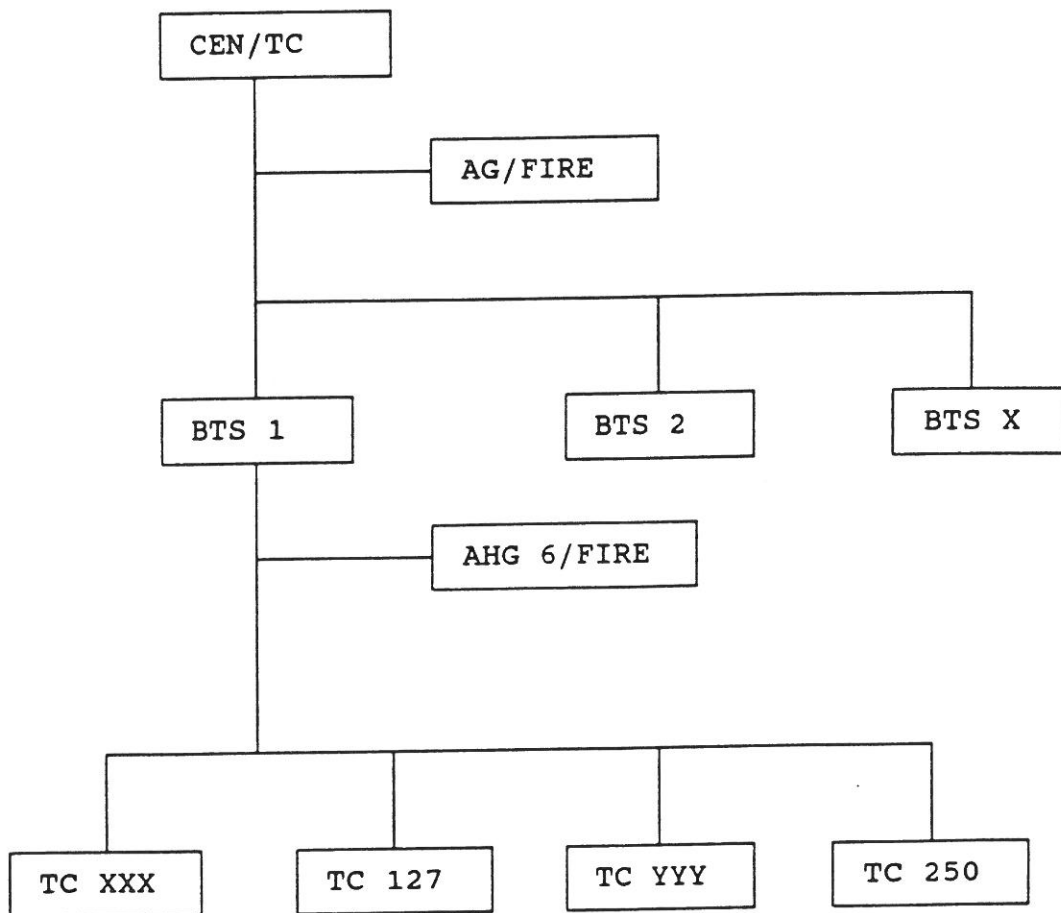
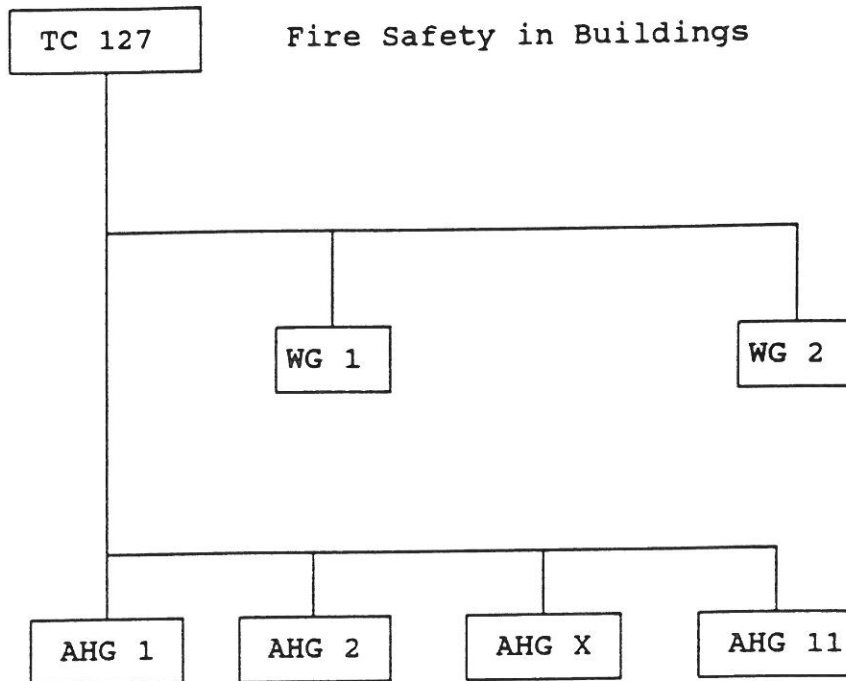

FIGURE 2



AHG NR. TITLE

1	Non-Combustibility
2	Ignitability, direct flame
4	Roofs
5	Door and Shutter Assemblies
6	Penetration Seals
7	Strategy
8	Smoke
9	Partitions
10	Additional requirements
11	Ventilation and Smoke Ducts

FIGURE 3

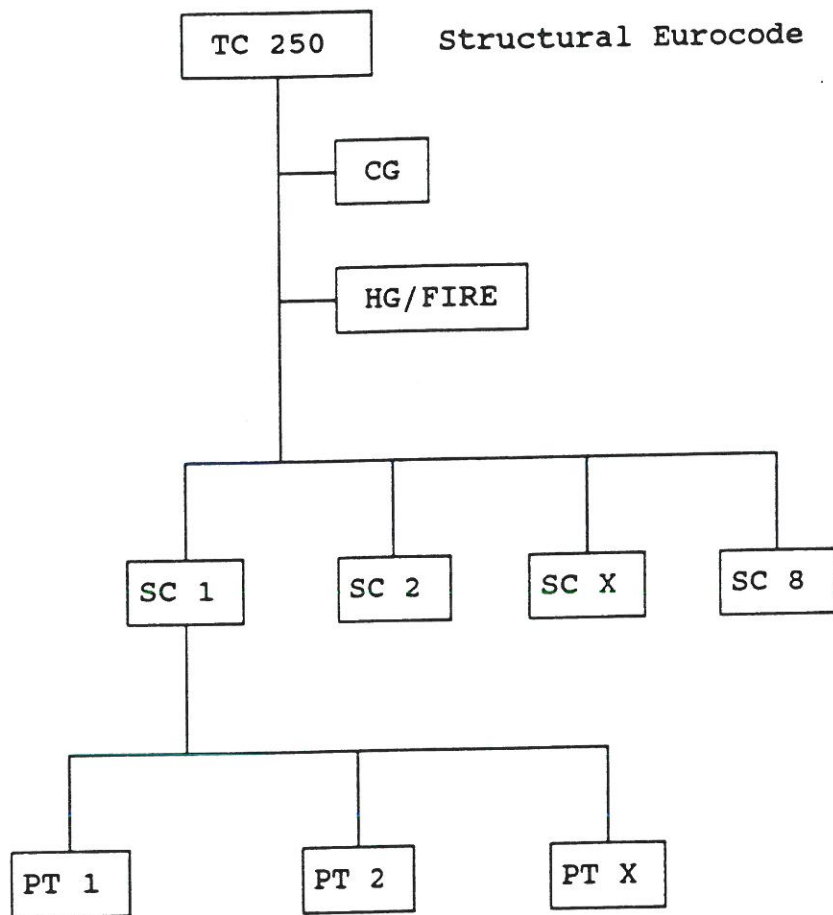

SC NR.	TITLE
1	Actions
2	Concrete
3	Steel
4	Composite
5	Timber
6	Masonry
7	Geotechnics
8	Seismic
9	Aluminium

FIGURE 4

Project Teams for Eurocodes, part Fire Design.

Eurocode no	Project Team	Members	Schedule
EC 1 part 20	CEN/TC250/SC1/PT9	Mrs. M.Kersken-Bradley (convenor) Mr. J. Kruppa Mr. L. Moser Mr. Setti Mr. L. Twilt Mr. U. Wickström	Final draft: oct. 92
EC 2 part 10	CEN/TC250/SC2/PT10	Mr. T. Hietanen (convenor) Mr. J. Dotreppe Mr. A. Gerritse Mrs. Lore Krampf Mr. R.T. Witte Mr. E. Radogna Permanently invited experts Mr. C. Chronopoulos Mr. K. Hertz Mr. H. Hölzenbein Mr. J. Izquierdo Mr. S. Kelly Mr. J. Mathez	Final draft: April 93

Eurocode no	Project Team	Members	Schedule
EC 3 part 10	CEN/TC250/SC3/PT10	Mrs. M. Laur (convenor) Mr. M.F. Fontana Mr. J. Kruppa Mr. L. Twilt Mr. J.C. Taylor	Final draft: April 93
EC 4 part 10	CEN/TC250/SC4/PT10	Mr. J.B. Schleich (convenor) Mr. J. Kruppa Mr. R.M. Lawson Mr. P. Schauman Mr. L. Twilt	Final draft: Sept. 93
EC 5 part 10	CEN/TC250/SC5/PT10	Mr. H. Hartl (convenor) Mr. G. Hall Mr. J. König Mr. J. Majama Mr. G. Sagot	Final draft: Sept. 92
EC 6 part 10	CEN/TC250/SC6/PT10	Mr. B.A. Haseltime Mr. C. Hann Mr. A.M. Waldum	Final draft: Oct. 93

Annemarie Poulsen