



**AALBORG UNIVERSITY**  
DENMARK

**Aalborg Universitet**

## **Identification of constitutive parameters for thin-walled aluminium tubes using a hybrid strategy**

Zhang, Bin; Endelt, Benny; Lang, Lihui; Nielsen, Karl Brian

*Published in:*  
Materials Today Communications

*DOI (link to publication from Publisher):*  
[10.1016/j.mtcomm.2021.102670](https://doi.org/10.1016/j.mtcomm.2021.102670)

*Creative Commons License*  
CC BY 4.0

*Publication date:*  
2021

*Document Version*  
Publisher's PDF, also known as Version of record

[Link to publication from Aalborg University](#)

*Citation for published version (APA):*  
Zhang, B., Endelt, B., Lang, L., & Nielsen, K. B. (2021). Identification of constitutive parameters for thin-walled aluminium tubes using a hybrid strategy. *Materials Today Communications*, 28, Article 102670. <https://doi.org/10.1016/j.mtcomm.2021.102670>

### **General rights**

Copyright and moral rights for the publications made accessible in the public portal are retained by the authors and/or other copyright owners and it is a condition of accessing publications that users recognise and abide by the legal requirements associated with these rights.

- Users may download and print one copy of any publication from the public portal for the purpose of private study or research.
- You may not further distribute the material or use it for any profit-making activity or commercial gain
- You may freely distribute the URL identifying the publication in the public portal -

### **Take down policy**

If you believe that this document breaches copyright please contact us at [vbn@aub.aau.dk](mailto:vbn@aub.aau.dk) providing details, and we will remove access to the work immediately and investigate your claim.

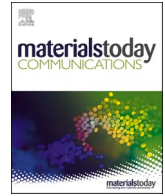

# Identification of constitutive parameters for thin-walled aluminium tubes using a hybrid strategy

Bin Zhang<sup>a,\*</sup>, Benny Endelt<sup>a</sup>, Lihui Lang<sup>b</sup>, Karl Brian Nielsen<sup>c</sup>

<sup>a</sup> Department of Materials and Production, Aalborg University, Aalborg 9220, Denmark

<sup>b</sup> School of Mechanical Engineering and Automation, Beihang University, Beijing 100083, China

<sup>c</sup> Department of Mechanical and Production Engineering, Aarhus University, Aarhus 8000, Denmark

## ARTICLE INFO

### Keywords:

Tubular material  
Hydraulic bulge test  
Theoretical analysis  
Finite element method  
Numerical optimization

## ABSTRACT

The paper presents a hybrid strategy to determine constitutive parameters for thin-walled tubes based on experimental responses from hydraulic bulge tests. This developed procedure integrates the analytical model, finite element analysis and gradient-based optimization algorithm, where initial guesses of material parameters are generated quickly by a theoretical method, then they are input to an inverse framework integrating Gauss-Newton algorithm and finite element method. The solving for this inverse problem leads to a more accurate identification of material parameters by reducing the discrepancies between simulated results and experimental data. To evaluate its feasibility and performance, hydraulic bulge tests with different end-conditions for annealed 6060 and 5049 aluminium tubes are carried out. The strength coefficient and hardening exponent are determined using the hybrid strategy based on the collected measurements in the experiment. These material parameters are used to compare with those obtained by a single analytical model and inverse model. The comparison validates that the proposed hybrid strategy is not sensitive to starting points and can improve the calculation efficiency and determine more accurate constitutive parameters.

## 1. Introduction

With the latest development of computing power, finite element (FE) method has become a widely used and standard technique to model and investigate tube hydroforming processes in industry or science community [1,2]. It not only can help engineers and researchers to design desired products by analyzing stress and strain distribution and predicting the shape and size of deformed tubular specimens [3], but can evaluate tube damages and forming limits on the whole production cycle instead of trial and error method of physical experiments [4,5]. One of the most critical prerequisites for a successful FE modelling is the input data of accurate tubular material constitutive parameters, which can be obtained by different post-processing procedures for a variety of material testing methods and responses [6–9].

The hydraulic bulging test has proven to be a simple and effective method to determine the flow stress curve for tubular materials [10,11], which can reproduce deformation stress state in the tube forming operation and is a better alternative to evaluate the overall mechanical characteristics of tubes compared with the tensile test [12], hoop tension

test [13,14], axial and lateral compression test [6,15]. Hydro-bulging equipment can construct flexible end-condition such as fixed ends [16], free ends [17,18] and forced ends [19] for tubular specimens and investigate their yielding and hardening behaviour under bi-axial and three-dimensional stress state [20]. During the test, the bulge diameter, thickness of meridian center point and corresponding liquid pressure are easily recorded. Then, theoretical models and fitting algorithms are used to further estimate the experimental data and determine the material stress-strain relationship.

Most of the existing analytical methods for modelling hydraulic bulge processes are based on the principle of membrane mechanics. Stress and strain tensors are determined separately by solving the force equilibrium equation and simplified plastic condition, and then these values are used to fit the assumed material model formula. Hwang et al. [18] propose a flow stress model in which stress components are derived based on force equilibrium and a plane stress hypothesis for deformed tubes, and strain components are calculated by assuming the bulge profile shape as an ellipse. Analytical models developed in subsequent works are similar to the classical Hwang model, where the stress formula

\* Corresponding author.

E-mail address: [zhangbin20100@outlook.com](mailto:zhangbin20100@outlook.com) (B. Zhang).

<sup>1</sup> Address: Department of Materials and Production, Aalborg University, Fibigerstræde 16, Aalborg DK-9220, Denmark.

in Hwang model is still used while the profile shape on the tube bulge region could be regarded as an circumference arc [21,22], spline function [17] and so on. It is obvious that all the above analytical models can guarantee the uniqueness and stability of the identified material parameters, but the application of geometrical and mechanical assumptions reduces the accuracy of these models.

Inverse modelling techniques can be used to estimate material constitutive parameters, which allows a more accurate parameter determination by eliminating the mechanical and geometrical hypothesis in classical theoretical analysis [23,24]. However, extensive research has been applied to determine the mechanical properties for sheet metals using different physical experiments [25–28] and limited work is performed for tubular materials. Based on various experimental tests, the inverse strategy combining corresponding FE models with different algorithms is developed to determine constitutive parameters for thin-walled tubes [29–32]. Although the utilization of inverse modelling method makes it possible to evaluate with better accuracy for responses from tube bulging tests, the introduction of FE models causes expensive calculation time [33]. Therefore, many scientists focus on improving the performance of optimization algorithms.

Classical gradient-based optimization algorithms like steepest descent, Gauss-Newton and Levenberg-Marquardt method, etc. [34] can solve the inverse problem with small residuals efficiently, but they are heavily dependent on the initial guesses and easily fall into the local minimum, especially in multi-objective optimization [35]. Another group of popular algorithms are called bioinspired approaches such as genetic algorithm, simulated annealing and so on which imitate some behaviours of natural and biological system and tends to find a global optimum for multi-objective optimization problems. However, one drawback for bioinspired algorithms is the requirement of a large number of function evaluations and this situation is particularly prominent in expensive FE model calculation [36]. The other type of way to solve inverse problem is meta-model based algorithms which use approximated model to replace sophisticated FE modelling. Response surface methodology, sequential kriging method, and neural networks are typical representatives of approximation models [33,37,38]. These algorithms not only can allow distributed and parallel calculations, but do not need the sensitivity analysis. One of the disadvantages of the approximation algorithm is that it only can get an approximate optimum rather than a real optimal result.

Several hybrid optimization strategies have been constructed to take advantages of selected algorithms and further improve the performance of inverse framework [30,35,39–43]. It is worth pointing out, a fuzzy logic-based approach is applied to choose the most reliable result from various material parameters calculated by common least square algorithms [40]. Ponthot et al. explore many possibilities of combining different gradient-based methods to determine material coefficients in hardening model based on cylindrical bar compression test [41]. A genetic algorithm is used to generate the initial points near the global minimums and then activate gradient-based algorithm to determine the optimum solution quickly while avoiding the local minimum trap [35]. Moreover, virtual orthogonal experiment [30], response surface design [33] and evolutionary algorithm [42] also provide more possibilities for mapping searching space of design variables to perform inverse parameter identification process efficiently. This cascade strategy is still time-consuming because of the utilization of the global searching algorithm in its first stage.

This study aims to find the global optimum for tubular material parameters efficiently by making full use of two different types of hydraulic bulge tests with fixed and forced end-condition. The research advances and challenges are described in state of the art of Section 1. In this paper, a novel hybrid strategy combining theoretical analysis with inverse model is developed to determine constitutive parameters of tubular material, which characterizes with improved efficiency and accuracy. The structure and working principle of this new strategy are described in detail in Section 2. To validate the feasibility and

performance of the proposed hybrid framework, two application cases on using this hybrid scheme to determine material properties of 5049 and 6060 aluminium tubes are presented in Section 3. In Section 4, identified material parameters using different models and their comparison for computational accuracy and efficiency are discussed. The main conclusions are drawn in Section 5.

## 2. The hybrid strategy

The developed hybrid scheme is a special framework for determining mechanical properties of tubular materials and combines theoretical analysis, FE model, optimization technique and responses from hydraulic bulge test, which can be divided into two stages. The purpose of the first stage is to produce the starting values in the vicinity of the optimal solution using a classical theoretical method named Hwang model [18]. Reasonable searching spaces can be found efficiently because of the simplicity and robustness of this analytical model. In the second stage, initial guesses from the first step will be imported into an inverse strategy which integrating FE model and Gauss-Newton algorithm to identify the final material parameters by reducing the error between experimental and simulated outputs. Gauss-Newton algorithm can converge to the minimum quickly near the global optimum solution and the introduction of FE models further improves the accuracy of results. Fig. 1 illustrates the flow chart of this hybrid strategy applied on the parameter identification for tubular materials.

### 2.1. Theoretical analysis

Hydraulic bulge test is an advanced material characterization technique where tubular specimens are deformed under hydraulic pressures with or without axial feeding forces, which can be divided into three categories, 1) free bulge test; 2) fixed bulge test; 3) forced bulge test, according to the different end-condition of tubular samples. The same theoretical analysis can be applied to both free and fixed bulging tests at the same time [44]. When considering the axial feeding force, the classical model needs to be updated.

The slab method can be used to analyse tube hydraulic bulge process with free or fixed ends by defining an equilibrium equation on a small element at tube pole. Fig. 2 shows a schematic diagram of the hydraulic bulge process and several important geometrical parameters are marked in this plot. Typical analytical models for tube hydraulic bulge process with free and fixed end-condition are derived from membrane theory. The stress in the radial direction can be ignored because of the small ratio of tube thickness to diameter. Based on the force equilibrium conditions, stress components along longitudinal and circumferential direction can be written as [18]:

$$\sigma_{\varphi} = \frac{P(R_{\theta_0} - t)^2}{2t(R_{\theta_0} - t/2)} \quad (1)$$

$$\sigma_{\theta} = \frac{P(R_{\theta_0} - t)}{2t(R_{\varphi_0} - t/2)}(2R_{\varphi_0} - R_{\theta_0} - t) \quad (2)$$

where  $t$  is the pole thickness at tube center under specified internal pressure  $P$ .  $R_{\theta_0}$  and  $R_{\varphi_0}$  are the curvature radius along meridian and circumferential direction at the center of tubes, which can be expressed as [44]:

$$R_{\varphi_0} = \frac{L^2(R_0 + h)}{4h(2R_0 + h)} \quad (3)$$

$$R_{\theta_0} = R_0 + h \quad (4)$$

in which  $R_0$  is the initial outer radius,  $L$  is the length of the tube deformation zone and  $h$  is the bulge height. When these data are measured in the experiment, strain components in axial and hoop directions can be given as:

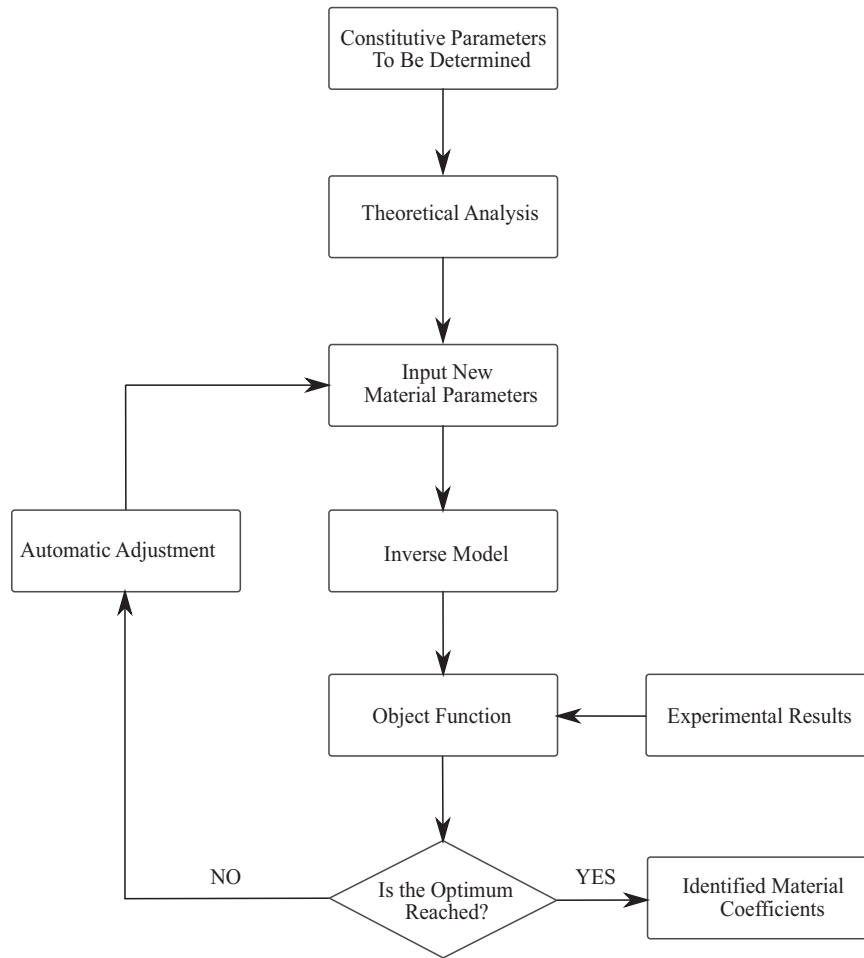

Fig. 1. Illustration of the flow chart for the proposed hybrid framework.

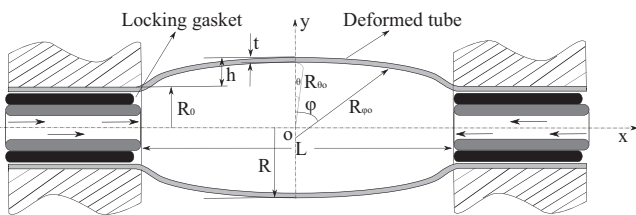

Fig. 2. Schematic diagram of the tube hydraulic bulge test with fixed end-condition.

$$\epsilon_r = \ln \frac{t}{t_0} \quad (5)$$

$$\epsilon_\theta = \ln \frac{(R_{\theta 0} - t_0/2)}{(R_0 - t_0/2)} \quad (6)$$

Based on the volume constancy in metal plastic forming, the strain in longitudinal direction can be derived as:

$$\epsilon_\varphi = -(\epsilon_r + \epsilon_\theta) \quad (7)$$

One-sided tube hydraulic bulge test with axial feeding force, which is illustrated in Fig. 3, can be used to characterize mechanical properties of tubular materials which are formed into complex components with angled branches such as T-shape, X-shape and Y-shape. Traditional slab methods are difficult to describe this forming process because of the poor symmetry of parts and the introduction of axial forces. Theoretical approaches based on energy balance provide a possibility to analyze this

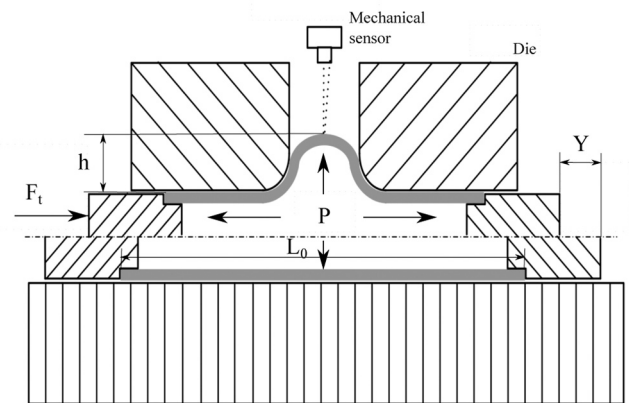

Fig. 3. Schematic diagram of the tube hydraulic bulge test with forced end-condition.

complex forming process [45]. Filho et al. [46] apply the upper bound method to calculate the total forming load for T-shape tube forming process using an elastomer as internal medium. Strano et al. [47] use a simple inverse approach based on energy balance to identify the strain-stress curve of tubular materials. Although the accuracy of the calculated parameters is low, but they can still be considered as the initial value of the inverse model.

In tube hydraulic bulge test with axial force, the tube deformation is

assumed as a plane strain state i.e. the longitudinal strain is zero. Strain components along radial and hoop direction can be written as [46]:

$$\epsilon_r = \ln \frac{t}{t_0} \tag{8}$$

$$\epsilon_\theta = -\epsilon_r \tag{9}$$

According to the energy theory, the power balance can be written as [46]:

$$J^* = \dot{W}_b + \dot{W}_i + \dot{W}_f \tag{10}$$

where  $J^*$  is the external power,  $\dot{W}_b$ ,  $\dot{W}_i$ ,  $\dot{W}_f$  are additional power applied on internal pressure medium, internal power and contact surface friction power, respectively. The derivation and solution of the above equations can produce an approximate formula to calculate the flow stress as [46]:

$$\bar{\sigma}_t = \frac{\sqrt{3}(F_t L_0 - A_i P Y)}{\pi L_0 [R_0^2 - (R_0 - t)^2 + c R_0 (L_0 - Y + h)]} \tag{11}$$

in which  $L_0$  is the initial length of a tube,  $F_t$  is the total external forming force,  $Y$  is the axial punch displacement,  $A_i$  is the area of punch cross section,  $c$  is the shear friction coefficient. It can be seen that more experimental data needs to be collected in tube hydraulic bulge test with axial feeding force.

According to the von Mises yield criterion, the effective stress and strain can be described as below:

$$\bar{\sigma} = \frac{1}{\sqrt{2}} \sqrt{(\sigma_r - \sigma_\theta)^2 + (\sigma_\theta - \sigma_\varphi)^2 + (\sigma_\varphi - \sigma_r)^2} \tag{12}$$

$$\bar{\epsilon} = \frac{\sqrt{2}}{3} \sqrt{(\epsilon_r - \epsilon_\theta)^2 + (\epsilon_\theta - \epsilon_\varphi)^2 + (\epsilon_\varphi - \epsilon_r)^2} \tag{13}$$

Therefore, the equivalent stress and strain under different pressure levels in two types of hydraulic tests can be obtained using presented equations above.

### 2.2. FE analysis and constitutive model

LS-DYNA FE software is used to simulate tube hydraulic forming processes with or without axial compressive force. The tubular specimen is meshed with hexahedral solid elements and the dies are set as a rigid body. The contact friction between the workpiece and the die is described by Coulomb's law. Internal fluid pressure and punch feeding displacement are collected in the experiments and the recorded data is imported into FE models.

The constitutive model contains the yield criterion and hardening law, which can describe the mechanical behaviour of tubular materials. In our current research, the selected material is a fully annealed aluminium alloy which features isotropic properties. Thus, von Mises yield criterion and power isotropic hardening law are assigned to solid elements, which can be defined as:

$$\sigma = K \epsilon^m \tag{14}$$

where  $K$  is the strength coefficient and  $m$  is the strain hardening exponent. These two values are also material parameters to be determined.

### 2.3. Objective function and constraint

An accurate determination of material parameters is very dependent on a reasonable cost function. The commonly used definition for objective functions are the sum of least square differences between simulated and experimental data, which proved to be a great success in parameter identification of metal forming processes [48,49]. However, some material parameters have different units or a wide magnitude of values, which can cause convergence difficulties or poor solution

accuracy. In this research, the logarithm form is introduced to define the error between the experimental and calculated data and the sum of these values constitutes the objective function [50].

In free hydraulic bulge test, the bulge height and pole thickness are considered as a part of the optimization objective. Following the least square structure, the cost function can be defined as below:

$$f_1 = \alpha f_{11} + (1 - \alpha) f_{12} \tag{15}$$

$$f_{11} = \sum_{i=1}^{n_1} \left[ \omega_i \ln \left( 1 + \frac{(h_i^{exp} - h_i^{sim})}{h_i^{exp}} \right) \right]^2 \tag{16}$$

$$f_{12} = \sum_{j=1}^{n_2} \left[ \omega_j \ln \left( 1 + \frac{(t_j^{exp} - t_j^{sim})}{t_j^{exp}} \right) \right]^2 \tag{17}$$

For hydraulic bulge test with axial force, more experimental data measured in the experiment need to be taken into the objective function in addition to the bulge height and thickness, which can be written as following:

$$f_2 = \alpha_1 f_{21} + \alpha_2 f_{22} + \alpha_3 f_{23} \tag{18}$$

$$f_{21} = \sum_{i=1}^{n_1} \left[ \omega_i \ln \left( 1 + \frac{(h_i^{exp} - h_i^{sim})}{h_i^{exp}} \right) \right]^2 \tag{19}$$

$$f_{22} = \sum_{j=1}^{n_2} \left[ \omega_j \ln \left( 1 + \frac{(t_j^{exp} - t_j^{sim})}{t_j^{exp}} \right) \right]^2 \tag{20}$$

$$f_{23} = \sum_{k=1}^{n_3} \left[ \omega_k \ln \left( 1 + \frac{(F_k^{exp} - F_k^{sim})}{F_k^{exp}} \right) \right]^2 \tag{21}$$

where  $h$ ,  $t$  and  $F$  are the bulge height, pole thickness and axial feeding force, respectively.  $n$  is the number of recorded experimental data.  $\omega$  is the weighted coefficient for different terms in the cost function, which can be expressed as:

$$\omega_i = N \frac{h_i^{exp}}{\sum_{i=1}^{n_1} \sum_{j=1}^{n_2} \sum_{k=1}^{n_3} (h_i^{exp} + t_j^{exp} + F_k^{exp})} \tag{22}$$

in which  $N$  is the total number of various experimental indicators. The remaining weighted coefficient in the cost function can be obtained by similar formulas.

In the hybrid framework, there are no many specified constraints on the material parameters because the flexibility and stability of this strategy needs to be verified. However, all constitutive parameters have to be ensured positive based on a real material behaviour. In the optimization process, the constraint that the strength coefficient and hardening exponent are larger than zero should be activated when the identified parameters are outside of the specified searching region.

### 2.4. Optimization method

A classical gradient-based method i.e. Gauss-Newton algorithm is used in the current study. The basic idea of Gauss-Newton algorithm [34] is to produce a quadratic approximation to the cost function at a given starting point. Then the approximated objective function will be minimized by an iterative procedure until the optimum point is found. When the Hessian matrix of the approximated function is positive definite, Gauss-Newton method can find the optimal solution with fewer iterations. However, the cost function is always so strongly nonlinear in parameter identification that causes some numerical convergence problems.

On the other hand, an initial point around the vicinity of the solution can produce a positive definite Hessian matrix and a good quadratic

function approximation to the objective function, where this algorithm can converge to the optimum point quickly. In order to improve the calculation speed and robustness of the algorithm, analytical model in Section 2.1 is used to generate the initial guesses at the neighborhood of the optimum and the application of trust region constraint instead of line search method enables it possible to solve a non-convex approximate quadratic function. In addition, the approximation of the Hessian matrix for the objective function is performed by the finite difference method. The structure of Gauss-Newton algorithm with trust region strategy is illustrated in Table 1.

### 3. Experimental procedure

#### 3.1. Sample material and geometry

Two types of tubular materials are used in this study, one of which is the fully annealed 5049 aluminium alloy tube made in China whose outer diameter is 50.00 mm and thickness is 1.086 mm. The total length of tubular samples in the test is 300.00 mm. The other one is the thin-walled EN-AW 6060-O aluminium alloy tube with the dimension 32.00 mm × 1.50 mm × 150.00 mm (diameter × thickness × length). In order to improve the accuracy of the experimental data, all tested tubular samples are cut from the same batch of supplied tubes.

#### 3.2. Testing tool and method

In order to verify the effectiveness of the proposed hybrid strategy, tube hydraulic bulge tests with and without axial feeding force are performed separately. Free hydraulic bulge tests for 5049-O aluminum tubes are carried out on an internal pressure press and a schematic diagram of this machine is illustrated in Fig. 4, where the tube ends are locked by a setup on this machine and the tube center part is freely expanded by the internal fluid pressure. Different pressure levels are applied on tested tubes and the bulge height and pole thickness are measured after deformation. The collected experimental data i.e. curves of the fluid pressure versus bulge height and pole thickness is used as the optimization objective in the developed hybrid framework.

One-sided hydraulic bulge tests with axial force for EN-AW 6060-O aluminium tubes are performed on an internal pressure-axial compression machine which is illustrated in Fig. 5. During the test, the axial feeding force from two punches and internal fluid pressure from an intensifier can be applied to tubular specimens at the same time. The filling height of the tube branch can be recorded online and the thickness at the top of specimens is measured after deformation. Besides, the axial compressive force and punch displacement are collected and imported into the hybrid strategy, which enable the simulation process more accurate and stable.

A remote high performance computer cluster named Hill is deployed to run FE simulations and solve the optimization design program, which is more powerful than a single computer in terms of computing performance. Hill cluster consists of five nodes and each node is running the Ubuntu GNU/Linux operating system which has 28 cores of Intel Xeon E5-2697 CPUs and 251GB of RAM. In the computation process, the number of CPUs and memory size are specified and set to the same to

**Table 1**  
The structure of Gauss-Newton algorithm with trust region strategy.

Step 0: The material parameters from theoretical analysis are given;
Step 1: If the cost function or its gradient at the current point satisfies the stopping criteria then stop;
Step 2: Calculate the Jacobian matrix and the damping factor $\mu_0$ in trust region strategy;
Step 3: Approximately solve the equation $(J^T J + \mu_0 D) s_k = -g$ and update the current material coefficients;
Step 4: Generate the new damping factor $\mu_0$ and repeat all steps until the optimum point is found.

compare the running speed of different optimization strategies.

## 4. Results and discussion

As shown above, two types of hydraulic tests for different tubular materials have been carried out to evaluate the effectiveness and robustness of the proposed hybrid framework. The experimental data and comparison results between this new strategy and other methods will be elaborated in this section.

#### 4.1. Tube hydraulic test with fixed end-condition

The used material is thin-walled 5049-O aluminium alloy tube in free bulge test and the cut tubular specimens are expanded only under the internal fluid pressure. One deformed sample after the test is illustrated in Fig. 6 and the measured bulge height and pole thickness are partially shown in Fig. 7 and 8. The proposed hybrid strategy and inverse model are chosen as post-processing procedures to minimize the objective function for the experimental data. Identified material parameters and iteration information are presented in Table 2.

As can be observed from the results, two different strategies can reduce the value of the cost function to a very low level and determine the corresponding constitutive coefficients in the defined hardening model. Meanwhile, material parameters obtained by the hybrid framework can converge to the similar results even if the initial strength coefficient and hardening exponent are far from the optimal solution e.g. set 1 and 6. The inverse model determines the same optimal material parameters when the starting point is around the vicinity of the global minimum such as set 2, 3, and 4. However, it produces a local minimum e.g. set 1 and 5 when the starting point is not close to the optimum. Therefore, the hybrid framework is more flexible and stable than the single inverse model because the introduction of an analytical model make it to avoid the trap of local optimums. It can also be used to identify material coefficients in the constitutive model even though there is no information of input tubes for users.

In the parameter identification process, the local minimum can reduce the accuracy of the results. Figs. 7 and 8 illustrate the fitted curve of internal pressure versus the bulge height and pole thickness to the experimental data using different strategies. It is shown that the final optimized curve using the inverse model with bad initial points i.e. far from the optimum has a great gap to the measured bulge height and pole thickness because the application of gradient-based algorithm makes the iteration process locally convergent. The hybrid strategy and inverse model with good starting points can lead to a good match with the experimental result.

For a more accurate quantitative analysis, the concept of the average error is introduced to evaluate the discrepancy between the simulation and experiment, which can be written as  $\psi = (D_{exp} - D_{sim})/D_{exp}$  where  $D_{exp}$  and  $D_{sim}$  are the experimental and calculated results, respectively. The predicted tube bulge profile from FE models using identified material parameters is compared with experimental data, which is plotted in Fig. 9. It can be observed that the simulated curve by the hybrid model has a good agreement with the measured data. The smallest average deviation 0.17% among 0.93%, 0.18%, 0.71% from the analytical model and inverse model with good and bad points also proves the point that the hybrid model seems to be the most accurate method in parameter identification problem. The biggest fitting error is generated by the analytical model because the mechanical and geometrical assumptions are made in the theoretical analysis.

Table 3 illustrates the comparison of CPU time using the hybrid strategy and inverse model. The initial set 5 are considered as an example, where the final material coefficients converge to the similar global optimums. It is possible to conclude that the hybrid strategy is more efficient than the single inverse model. 40 FE simulations are performed to meet the stopping criteria in the inverse model and the hybrid framework only take 32 FE model evaluations. Indeed, the total

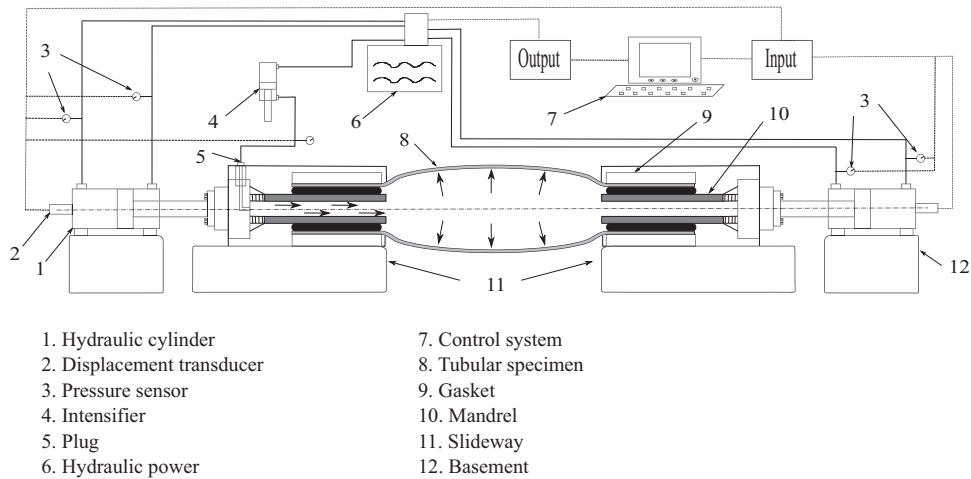

Fig. 4. Schematic diagram of experimental setup for tube hydraulic test with fixed end-condition.

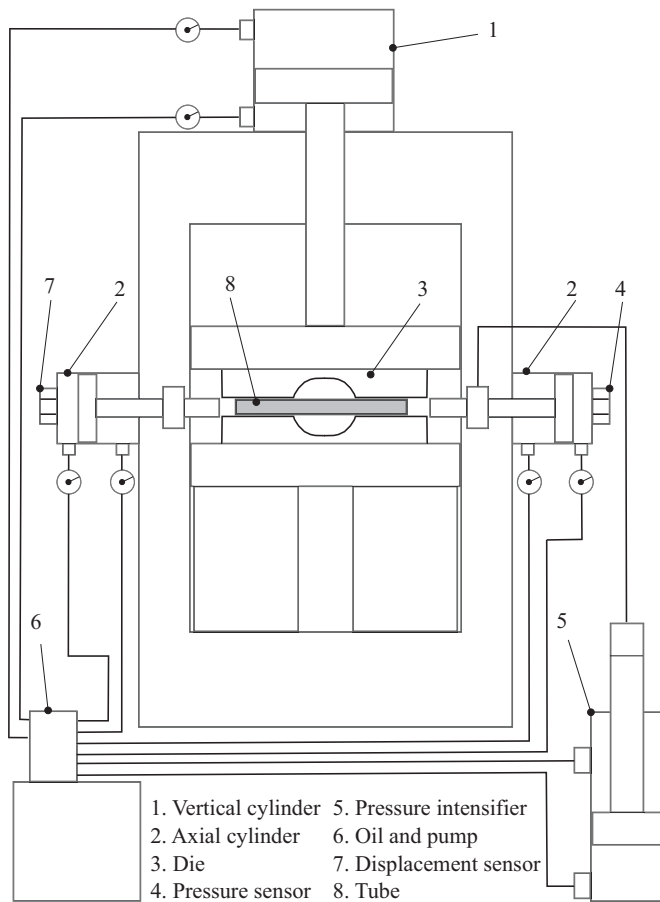

Fig. 5. Schematic diagram of experimental setup for tube hydraulic test with forced end-condition.

CPU time of 20% is reduced because of the application of this proposed hybrid strategy, where the analytical model can obtain a better searching space for design variables and reduce the iteration times for the second stage optimization process.

#### 4.2. Tube hydraulic test with forced end-condition

In the hydraulic bulge test for 6060-O aluminium alloy tubes, the punch force and internal fluid pressure are exposed on the tubular



Fig. 6. Illustration of the initial and deformed 5049-O aluminium tubes in hydraulic bulge test with fixed end-condition.

specimens and the total punch axial feeding displacement is 36.00 mm. At the end of the experiment, recorded experimental results contain the axial displacement versus the filling height and punch force. The shape of the tubular sample before and after deformation is shown in Fig. 10. Based on the experimental data, material parameters in defined power hardening laws are identified using different methods, which are presented in Table 4.

From the results, it can be seen that the hybrid model is more robust than the separate inverse model. The robustness of different methods can be estimated using the quality of the solution and the range of initial values. For the inverse model, different optimal solutions are obtained, which means that the cost function has several local minimums. Furthermore, the identified constitutive parameters from the initial set 2–7 converge to the similar values when the starting points are the vicinity of the optimum results. However, the identification process falls into the trap of local minimums when the initial values are far from the optimum solution, which can be seen from the set 1, 8. For the hybrid model, a wider range of initial values is used where the strength

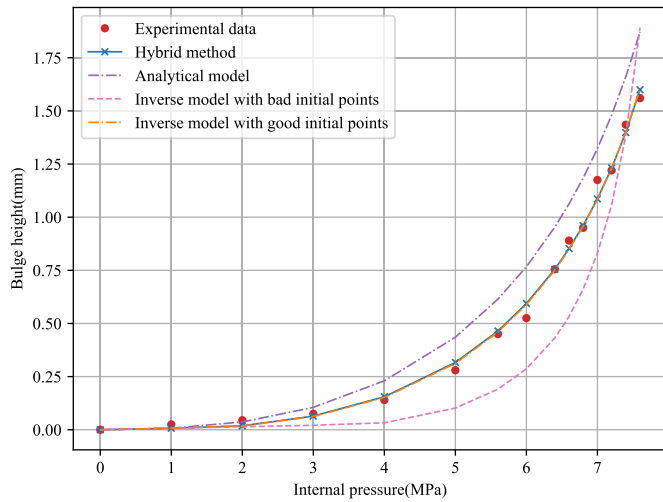

Fig. 7. Comparison of the internal pressure versus bulge height curve determined by different methods for 5049-O aluminium tubes.

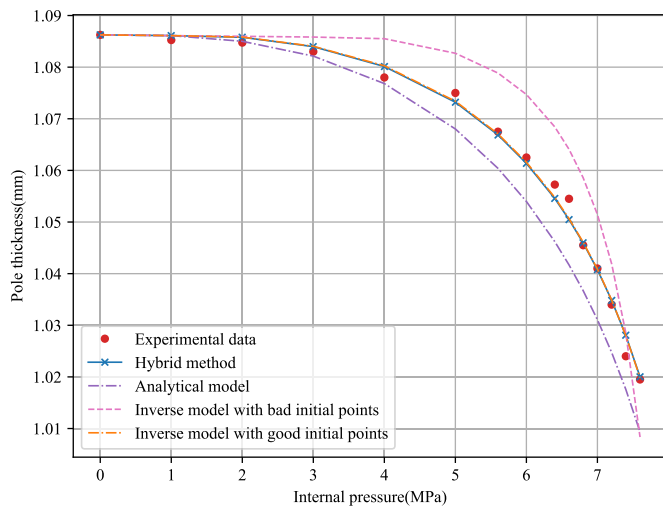

Fig. 8. Comparison of the internal pressure versus pole thickness curve determined by different methods for 5049-O aluminium tubes.

coefficient is from 100 to 1000 and hardening exponent is from 0.1 to 0.9. The identical material parameters are finally determined and this improvement can be attributed to the good searching space generated by the theoretical analysis in the first stage of the hybrid model.

The efficiency of different methods can be evaluated using

Table 2

Identified material parameters for 5049-O aluminium tubes based on hydraulic bulge test with fixed end-condition.

	set	Initial $x_0$				Optimum $x^*$				Iteration
		K (MPa)	m	$f(x_0)$	$f'(x_0)$	K (MPa)	m	$f(x^*)$	$f'(x^*)$	
Inverse model	1	100.00	0.10	1.06E+2	8.47E+2	260.62	0.179	3.79E-1	7.27E+0	18
	2	300.00	0.20	1.16E+0	4.39E+1	380.17	0.311	1.28E-2	9.05E-1	10
	3	350.00	0.25	8.88E-1	3.52E+1	382.29	0.313	1.27E-2	6.30E-1	9
	4	400.00	0.30	5.35E-1	2.77E+1	380.89	0.312	1.27E-2	5.69E-1	10
	5	500.00	0.25	2.80E+0	1.16E+1	472.60	0.262	2.47E+0	1.66E+1	12
Hybrid model	1	100.00	0.10	1.06E+2	8.47E+2	383.32	0.313	1.27E-2	6.31E-1	8
	2	300.00	0.20	1.16E+0	4.39E+1	383.79	0.313	1.30E-2	1.35E+0	8
	3	350.00	0.25	8.88E-1	3.52E+1	382.63	0.312	1.29E-2	1.15E+0	8
	4	400.00	0.30	5.35E-1	2.77E+1	381.96	0.311	1.76E-2	4.62E+0	8
	5	500.00	0.25	2.80E+0	1.16E+1	382.09	0.312	1.28E-2	9.35E-1	8
	6	1000.00	0.90	8.35E+0	4.74E+1	382.46	0.313	1.29E-2	1.08E+0	8
Stable value					382.71	0.312				

calculation time i.e. the number of iterations. The computational cost of FE models dominates the total time in each iteration, so it can serve as a detailed evaluation criterion. It can be observed in Table 4 and considering the initial set 7 as an example, 28 evaluations of FE models (f-evaluation) are performed in the hybrid model. As a comparison, the inverse model needs 48 f-evaluations and converges to the final material parameters when the starting points are far from the optimum one. The quantitative evaluation of calculation time for these two methods is displayed in Table 3, where the hybrid model can save 42% of the running time. An iteration history for the objective function and its gradient, two design variables is presented in Figs. 11 and 12. It can be seen that these two methods can provide a stable parameter identification process while the hybrid model needs fewer iterations compared to

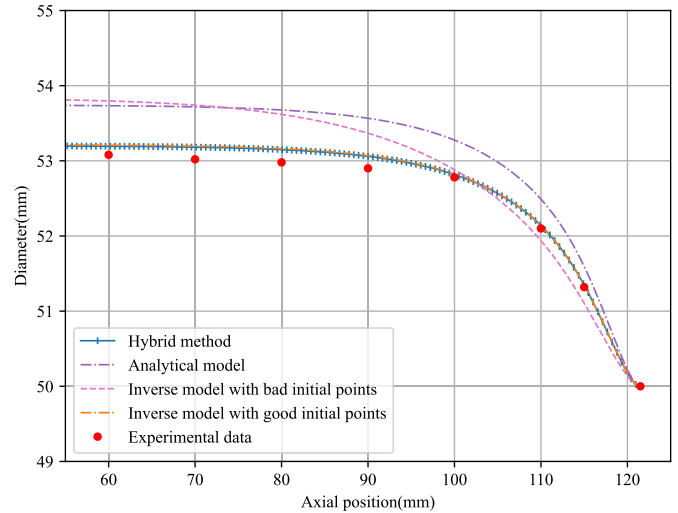

Fig. 9. Comparison of the axial position versus bulge shape profile curve determined by different methods for 5049-O aluminium tubes.

Table 3

Comparison of calculation time using different methods.

Hydraulic bulge test	Forced end-condition		Fixed end-condition	
	Hybrid model	Inverse model	Hybrid model	Inverse model
Number of CPU's	16	16	28	28
Memory(MB)	400	400	400	400
Number of FE model evaluation	28	48	32	40
Run time of each FE simulation(min)	14.63	14.63	12.41	12.41
The total time(h)	6.83	11.70	6.62	8.27





Fig. 10. Illustration of the initial and deformed 6060-O aluminium tubes in hydraulic bulge test with forced end-condition.

the inverse model. However, the computational efficiency of hybrid model has no significant improvements compared with the inverse model with good initial guesses.

Fig. 13 illustrates the comparison of the filling height versus axial displacement curve between experimental data and simulation results of FE models using identified constitutive parameters by different methods. It can be seen that the hybrid method leads to a good match between the simulated and experimental results as well as the inverse model with good initial points. Besides, a great gap can be observed when using the single analytical model and inverse model with bad initial guesses. On the other hand, the predicted punch force by FE models with material coefficients from different methods is compared with that recorded in the experiment, which is plotted in Fig. 14. It is found that the simulated results using the flow stress curve from the hybrid model and inverse model with good initial guesses have a small difference and can match the experimental data better than the analytical model and inverse model with bad starting points.

As an accuracy evaluation, the quantitative analysis for the deviation of the predicted bulge height and punch compressive force to experiment data are performed using the formula in Section 4.1. The average deviation of the filling height is 2.69% generated by the hybrid framework, which is the smallest value among 28.93%, 7.61%, 2.80% obtained by corresponding analytical model, inverse model with bad and good initial values. For the mean error of the punch force, the hybrid

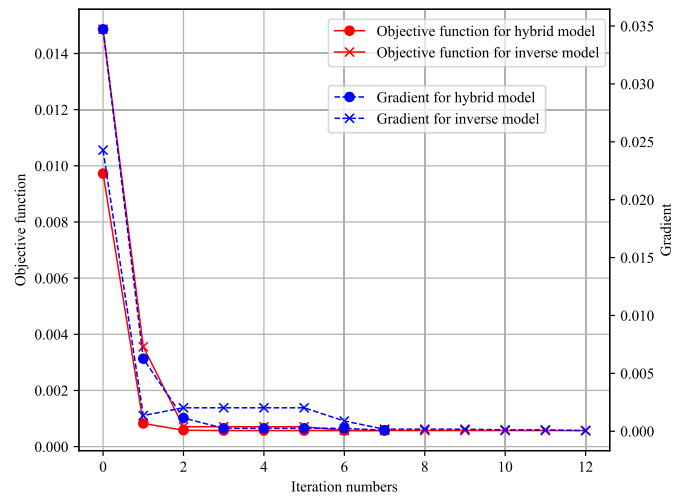

Fig. 11. Iteration history of the cost function and its gradient using initial set 7.

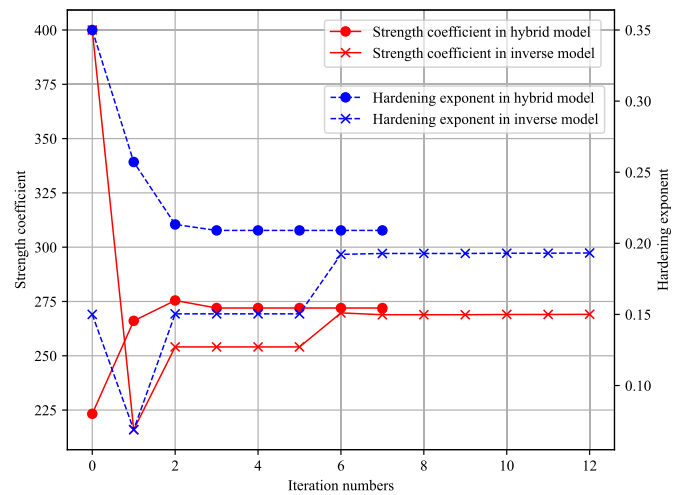
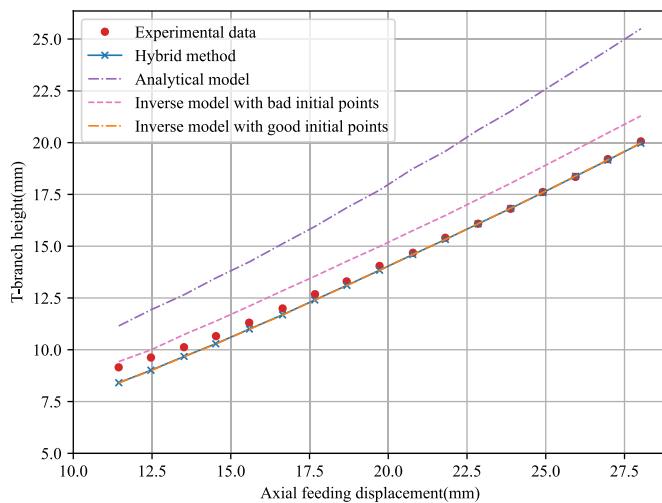

Fig. 12. Iteration history of two design variables using initial set 7.

Table 4  
Identified material parameters for 6060-O aluminium tubes based on hydraulic bulge test with forced end-condition.

	set	Initial $x_0$				Optimum $x^*$				Iteration
		K (MPa)	m	$f(x_0)$	$f'(x_0)$	K (MPa)	m	$f(x^*)$	$f'(x^*)$	
Inverse model	1	100.00	0.10	2.01E-1	9.18E-1	110.17	0.087	1.65E-3	2.39E-5	8
	2	150.00	0.15	4.14E-2	7.71E-2	271.44	0.204	5.69E-4	5.67E-5	9
	3	200.00	0.20	1.09E-2	5.43E-2	269.95	0.207	5.72E-4	7.96E-4	6
	4	250.00	0.25	1.99E-3	2.01E-2	271.73	0.206	5.70E-4	1.08E-4	7
	5	300.00	0.30	9.22E-4	3.36E-3	270.34	0.204	5.72E-4	3.54E-5	7
	6	400.00	0.40	6.12E-3	2.13E-2	271.25	0.202	5.71E-4	8.69E-6	8
	7	400.00	0.15	1.49E-2	2.43E-2	269.08	0.193	5.71E-4	5.13E-5	12
	8	1000.00	0.90	5.06E-2	2.55E-2	190.61	0.616	6.06E-4	8.57E-5	11
Hybrid model	1	100.00	0.10	2.00E-1	9.18E-1	271.98	0.209	5.70E-4	7.93E-5	7
	2	150.00	0.15	4.15E-2	7.70E-2	271.91	0.207	5.70E-4	1.12E-4	7
	3	200.00	0.20	1.09E-2	5.43E-2	269.92	0.209	5.73E-4	2.83E-5	7
	4	250.00	0.25	1.99E-3	2.01E-2	271.90	0.207	5.69E-4	1.11E-5	7
	5	300.00	0.30	9.22E-4	3.36E-3	270.59	0.201	5.70E-4	1.73E-5	7
	6	400.00	0.40	6.12E-3	2.13E-2	271.70	0.205	5.72E-4	7.15E-5	7
	7	400.00	0.15	1.49E-2	2.43E-2	271.23	0.200	5.70E-4	4.78E-6	7
	8	1000.00	0.90	5.06E-2	2.55E-2	270.94	0.210	5.71E-4	8.47E-5	7
Stable value					271.27	0.206				



**Fig. 13.** Comparison of the axial displacement versus T-branch height curve determined by different identification methods for 6060-O aluminium tubes.

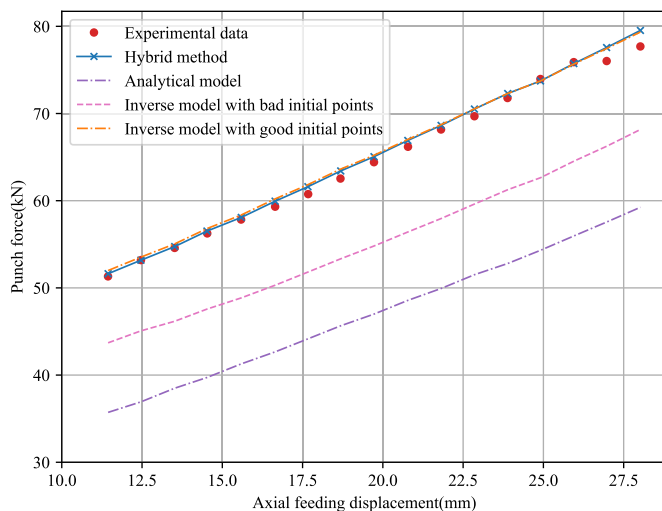

**Fig. 14.** Comparison of the axial displacement versus punch force curve determined by different identification methods for 6060-O aluminium tubes.

model and inverse model with good starting points present a better fitting with the 0.90% and 1.15% deviation. The other two methods with 27.33% and 14.72% error have a bad match to the experimental data. This quantitative analysis is consistent with observation in Fig. 13 and 14.

From these comparisons, it can be seen that the developed hybrid strategy can be used to determine material coefficients in constitutive models of the tubular metal and presents a more strong robustness and accuracy in parameter identification process compared with the other two methods. One possible reason is that the simplest theoretical model uses the plane strain or stress assumption and the tube profile shape is considered as a specific geometrical shape, whose two assumptions make it possible to quickly solve the equilibrium equation but reduce the accuracy of the solution. The inverse scheme is based on the incremental theory, which can obtain more accurate solutions but increase the model complexity and the computational cost. At the same time, the introduction of gradient-based algorithms makes it more dependent on the initial guesses.

## 5. Conclusion

A novel hybrid framework is developed to identify constitutive parameters of tubular materials, which combines the theoretical analysis, FE simulation and Gauss-Newton optimization algorithm. Hydraulic bulge tests with fixed and forced end-condition are carried on for annealed 5049 and 6060 aluminum alloy tubes separately to generate an experimental database and validate the feasibility and performance of the proposed inverse strategy. Material coefficients in Hollomon hardening law are determined using the hybrid scheme, inverse model and analytical method based on the experimental data. Through the analysis and comparison of obtained results, the following conclusions can be drawn: .

- (1) Tube hydraulic bulge test with fixed and forced end-condition is suitable for characterization the mechanical properties of seamless thin-walled aluminium alloy tubes at different strain ranges. Strength coefficient  $K$  and hardening exponent  $m$  can be determined by means of three models described in this paper.
- (2) The analytical model can achieve a fast parameter identification but the accuracy of the solution is low. Material parameters determined by the inverse model are more accurate than the theoretical analysis while the inverse model always converges to the local minimum and increases the computational cost when the initial guesses are far from the optimum points.
- (3) The proposed hybrid strategy takes all advantages of the above two models and can obtain the global optimum efficiently, where the reasonable searching space around the vicinity of the global minimum is generated by an analytical model in the first stage then the optimal parameters are quickly determined using the trust region algorithm. The computation cost of the hybrid method can be saved by 20% compared with classical methods.
- (4) Based on material parameters identified by three methods, the predicted bulge height, punch compressive force and pole thickness from FE simulations are used to compare with the experimental data. The results show that the simulated outputs using material parameters obtained by the hybrid scheme have a better agreement with the experimental data and the developed hybrid framework is more accurate than the other two models.

## CRedit authorship contribution statement

**Bin Zhang:** Methodology, Software, Investigation, Formal analysis, Data curation, Writing – original draft, Visualization. **Benny Endelt:** Conceptualization, Methodology, Investigation, Writing – review & editing. **Lihui Lang:** Resources, Writing – review & editing. **Karl Brian Nielsen:** Supervision, Writing – review & editing.

## Declaration of Competing Interest

The authors declare that they have no known competing financial interests or personal relationships that could have appeared to influence the work reported in this paper.

## Data Availability

The raw data required to reproduce these findings can be available from the corresponding author upon reasonable request.

## Acknowledgments

This work was partially supported by China Scholarship Council (CSC) (No. 201706080020) from the Ministry of Education of PR China and authors express their appreciation to CSC for their financial support.

## References

- [1] A. Alaswad, K. Benyounis, A. Olabi, Tube hydroforming process: a reference guide, *Mater. Des.* 33 (2012) 328–339.
- [2] C. Bell, J. Corney, N. Zuelli, D. Savings, A state of the art review of hydroforming technology: its applications, research areas, history, and future in manufacturing, *Int. J. Mater. Form.* 13 (2020) 789–828.
- [3] H. Ahmadi, M. Zohoor, Investigation of the effective parameters in tube hydroforming process by using experimental and finite element method for manufacturing of tee joint products, *Int. J. Adv. Manuf. Technol.* 93 (2017) 393–405.
- [4] W. Volk, P. Groche, A. Brosius, A. Ghiotti, B.L. Kinsey, M. Liewald, L. Madej, J. Min, J. Yanagimoto, Models and modelling for process limits in metal forming, *CIRP Ann.* 68 (2019) 775–798.
- [5] H. Zhu, Z. He, Y. Lin, K. Zheng, X. Fan, S. Yuan, The development of a novel forming limit diagram under nonlinear loading paths in tube hydroforming, *Int. J. Mech. Sci.* 172 (2020), 105392.
- [6] M. Nemat-Alla, Reproducing hoop stress-strain behavior for tubular material using lateral compression test, *Int. J. Mech. Sci.* 45 (2003) 605–621.
- [7] F. Bardi, S. Kyriakides, Plastic buckling of circular tubes under axial compression-part I: experiments, *Int. J. Mech. Sci.* 48 (2006) 830–841.
- [8] L. Vitu, N. Boudeau, P. Malécot, G. Michel, A. Buteri, Evaluation of models for tube material characterization with the tube bulging test in an industrial setting, *Int. J. Mater. Form.* 11 (2018) 671–686.
- [9] J. Yoon, J. Kim, H. Kim, C. Won, Y. Song, S.H. Park, Calibration of hoop stress in ring tensile test with Zircaloy-4 tube, *J. Mech. Sci. Technol.* 31 (2017) 4183–4188.
- [10] D. Woo, P. Hawkes, Determination of stress/strain characteristics of tubular materials, *J. Inst. Met.* 96 (1968) 357–359.
- [11] M. Koç, Y. Aue-u lan, T. Altan, On the characteristics of tubular materials for hydroforming-experimentation and analysis, *Int. J. Mach. Tools Manuf.* 41 (2001) 761–772.
- [12] ASTM E8. Standard test methods for tension testing of metallic materials, Technical Report, 2013.
- [13] H. Wang, P. Martin, Tube formability assessment for tube hydroforming, *J. Mater. Manuf.* 111 (2002) 880–889.
- [14] A. Khalfallah, Z. Ktari, C. Leitão, J.V. Fernandes, New mandrel design for ring hoop tensile testing, *Exp. Tech.* (2021).
- [15] F. Alhussainy, M.N. Sheikh, M.N. Hadi, Behaviour of small diameter steel tubes under axial compression, *Structures* 11 (2017) 155–163.
- [16] B. Zhang, B. Endelt, L. Lang, Y. Zhao, S. Yan, K.B. Nielsen, An inverse strategy to determine constitutive parameters of tubular materials for hydroforming process, *Chin. J. Aeronaut.* (2021) Accepted.
- [17] L. Yang, C. Ge, Determination of stress-strain relationship of tubular material with hydraulic bulge test, *Thin Walled Struct.* 46 (2008) 147–154.
- [18] Y.-M. Hwang, Y.-K. Lin, T. Altan, Evaluation of tubular materials by a hydraulic bulge test, *Int. J. Mach. Tools Manuf.* 47 (2007) 343–351.
- [19] X. Wang, W. Hu, S. Huang, R. Ding, Experimental investigations on extruded 6063 aluminium alloy tubes under complex tension-compression stress states, *Int. J. Solids Struct.* 168 (2019) 123–137.
- [20] X. Cui, S. Yuan, Determination of mechanical properties of anisotropic thin-walled tubes under three-dimensional stress state, *Int. J. Adv. Manuf. Technol.* 87 (2016) 1917–1927.
- [21] N. Boudeau, P. Malécot, A simplified analytical model for post-processing experimental results from tube bulging test: theory, experimentations, simulations, *Int. J. Mech. Sci.* 65 (2012) 1–11.
- [22] R. Velasco, N. Boudeau, Tube bulging test: theoretical analysis and numerical validation, *J. Mater. Process. Technol.* 205 (2008) 51–59.
- [23] O. Ghouti, J.-C. Gelin, A finite element-based identification method for complex metallic material behaviours, *Comput. Mater. Sci.* 21 (2001) 57–68.
- [24] G. Rauchs, J. Bardon, Identification of elasto-viscoplastic material parameters by indentation testing and combined finite element modelling and numerical optimization, *Finite Elem. Anal. Des.* 47 (2011) 653–667.
- [25] S. Schmaltz, K. Willner, Comparison of different biaxial tests for the inverse identification of sheet steel material parameters, *Strain* 50 (2014) 389–403.
- [26] P.A. Prates, M.C. Oliveira, J.V. Fernandes, Identification of material parameters for thin sheets from single biaxial tensile test using a sequential inverse identification strategy, *Int. J. Mater. Form.* 9 (2016) 547–571.
- [27] P.A. Prates, A.F.G. Pereira, N.A. Sakharova, M.C. Oliveira, J.V. Fernandes, Inverse strategies for identifying the parameters of constitutive laws of metal sheets, *Adv. Mater. Sci. Eng.* 2016 (2016) 1–18.
- [28] A. Pereira, P. Prates, M. Oliveira, J. Fernandes, Inverse identification of the work hardening law from circular and elliptical bulge tests, *J. Mater. Process. Technol.* 279 (2020), 116573.
- [29] Z. Ktari, C. Leitão, P.A. Prates, A. Khalfallah, Mechanical design of ring tensile specimen via surrogate modelling for inverse material parameter identification, *Mech. Mater.* 153 (2021), 103673.
- [30] J. Liu, H. Yang, H.W. Li, H. Li, S. Zhu, A new hybrid identification method for determining the material parameters of thin-walled tube under compressive stress state, *Mater. Des.* 44 (2013) 49–58.
- [31] T. Zribi, A. Khalfallah, H. BelHadjsalah, Experimental characterization and inverse constitutive parameters identification of tubular materials for tube hydroforming process, *Mater. Des.* 49 (2013) 866–877.
- [32] A. Khalfallah, M.C. Oliveira, J.L. Alves, T. Zribi, H. Belhadjsalah, L.F. Menezes, Mechanical characterization and constitutive parameter identification of anisotropic tubular materials for hydroforming applications, *Int. J. Mech. Sci.* 104 (2015) 91–103.
- [33] M.H.A. Bonte, A.H. van den Boogaard, J. Huétink, An optimisation strategy for industrial metal forming processes: modelling, screening and solving of optimisation problems in metal forming, *Struct. Multidiscip. Optim.* 35 (2008) 571–586.
- [34] W. Sun, Y. Yuan, *Optimization Theory and Methods: Nonlinear Programming*, Springer, New York, 2006.
- [35] B. Chaparro, S. Thuillier, L. Menezes, P. Manach, J. Fernandes, Material parameters identification: gradient-based, genetic and hybrid optimization algorithms, *Comput. Mater. Sci.* 44 (2008) 339–346.
- [36] G.M. Kakandikar, V.M. Nandedkar, *Sheet Metal Forming Optimization: Bioinspired Approaches*, CRC Press, Boca Raton, 2018.
- [37] C. Huang, A.E. Hami, B. Radi, Metamodel-based inverse method for parameter identification: elastic-plastic damage model, *Eng. Optim.* 49 (2017) 633–653.
- [38] Y. Tsompanakis, N.D. Lagaros, G.E. Stavroulakis, Soft computing techniques in parameter identification and probabilistic seismic analysis of structures, *Adv. Eng. Softw.* 39 (2008) 612–624.
- [39] M. Vaz, M.A. Luersen, P.A. Muñoz-Rojas, R.G. Trentin, Identification of inelastic parameters based on deep drawing forming operations using a global-local hybrid Particle Swarm approach, *Comptes Rendus Mécanique* 344 (2016) 319–334.
- [40] M. Wójcik, A. Skrzat, Identification of Chaboche-Lemaitre combined isotropic-kinematic hardening model parameters assisted by the fuzzy logic analysis, *Acta Mech.* 232 (2021) 685–708.
- [41] J.P. Ponthot, J.P. Kleinermann, A cascade optimization methodology for automatic parameter identification and shape/process optimization in metal forming simulation, *Comput. Methods Appl. Mech. Eng.* 195 (2006) 5472–5508.
- [42] R. de Carvalho, R.A.F. Valente, A. Andrade-Campos, Optimization strategies for non-linear material parameters identification in metal forming problems, *Comput. Struct.* 89 (2011) 246–255.
- [43] R.A.F. Valente, A. Andrade-Campos, J.F. Carvalho, P.S. Cruz, Parameter identification and shape optimization: an integrated methodology in metal forming and structural applications, *Optim. Eng.* 12 (2011) 129–152.
- [44] Z. He, S. Yuan, Y. Lin, X. Wang, W. Hu, Analytical model for tube hydro-bulging test, part I: models for stress components and bulging zone profile, *Int. J. Mech. Sci.* 87 (2014) 297–306.
- [45] K. Osakada, History of plasticity and metal forming analysis, *J. Mater. Process. Technol.* 210 (2010) 1436–1454.
- [46] L. Moreira Filho, H. Al-Quereshi, Unconventional tee forming on metal tubes, *J. Manuf. Sci. Eng.* 107 (1985) 392–396.
- [47] M. Strano, T. Altan, An inverse energy approach to determine the flow stress of tubular materials for hydroforming applications, *J. Mater. Process. Technol.* 146 (2004) 92–96.
- [48] B. Endelt, J. Danckert, Identification of friction coefficients and hardening parameters using optimization methods coupled with a 3D finite element code, *J. Mater. Process. Technol.* 209 (2009) 4005–4010.
- [49] B. Endelt, Least square optimization techniques applied on sheet metal forming - Inverse identification of constitutive parameters and optimization of process parameters, Ph.D. thesis, Aalborg University, Denmark, 2003.
- [50] A. Andrade-Campos, R. de Carvalho, R. Valente, Novel criteria for determination of material model parameters, *Int. J. Mech. Sci.* 54 (2012) 294–305.