



Aalborg Universitet

AALBORG UNIVERSITY
DENMARK

Investigating the flexibility of a novel multi-zone air heating and ventilation system using model predictive control

Khatibi, Mahmood; Rahnama, Samira; Vogler-Finck, Pierre; Bendtsen, Jan Dimon; Afshari, Alireza

Published in:
Journal of Building Engineering

DOI (link to publication from Publisher):
[10.1016/j.jobe.2022.104100](https://doi.org/10.1016/j.jobe.2022.104100)

Creative Commons License
CC BY 4.0

Publication date:
2022

Document Version
Publisher's PDF, also known as Version of record

[Link to publication from Aalborg University](#)

Citation for published version (APA):
Khatibi, M., Rahnama, S., Vogler-Finck, P., Bendtsen, J. D., & Afshari, A. (2022). Investigating the flexibility of a novel multi-zone air heating and ventilation system using model predictive control. *Journal of Building Engineering*, 49, Article 104100. <https://doi.org/10.1016/j.jobe.2022.104100>

General rights

Copyright and moral rights for the publications made accessible in the public portal are retained by the authors and/or other copyright owners and it is a condition of accessing publications that users recognise and abide by the legal requirements associated with these rights.

- Users may download and print one copy of any publication from the public portal for the purpose of private study or research.
- You may not further distribute the material or use it for any profit-making activity or commercial gain
- You may freely distribute the URL identifying the publication in the public portal -

Take down policy

If you believe that this document breaches copyright please contact us at vbn@aub.aau.dk providing details, and we will remove access to the work immediately and investigate your claim.



Investigating the flexibility of a novel multi-zone air heating and ventilation system using model predictive control

Mahmood Khatibi^{a,*}, Samira Rahnama^b, Pierre Vogler-Finck^c,
Jan Dimon Bendtsen^a, Alireza Afshari^b

^a Department of Electronic Systems, Aalborg University, Aalborg, Denmark

^b Department of the Built Environment, Aalborg University, Copenhagen, Denmark

^c Neogrid Technologies Aps, Aalborg, Denmark

ARTICLE INFO

Keywords:

Air heating systems
Flexibility
Model predictive control
Multi zone buildings

ABSTRACT

In forced air heating systems, there are basically two approaches to set the temperature of each zone within a multi-zone building: regulating the supply airflow rate and regulating the supply air temperature (or a combination of these two parameters). Conventional variable air volume (VAV) systems usually maintain the supply air temperature constant within all rooms and regulate only the supply airflow rate to the room. Recently, a novel multi-zone air heating and ventilation (MZHV) system has been developed, which is capable of regulating both the supply airflow rate and the supply air temperature to the rooms independently of each other. This paper investigates the flexibility of the novel MZHV system and compares it with the conventional VAV systems. The MZHV system as well as a multi-zone case study building are modeled in a high-fidelity simulation environment (IDA ICE). Instead of traditional rule-based control schemes, a model predictive control (MPC) scheme is developed to control real-time power consumption of the multi-zone building. For this purpose, a second-order state space model is identified for each zone and calibrated against the results from the high fidelity simulations. MPC is implemented in MATLAB environment by using the second-order state space models. Two co-simulations are performed to compare the flexibility of the novel MZHV system with a conventional VAV system. The results show that the MZHV system provides a significant flexibility in terms of the energy usage, without affecting the comfort levels. This flexibility can for example be exploited to reduce the overall energy usage or provide ancillary services for a smart electricity grid.

Nomenclature

Notations

x_i	The i^{th} element of the vector x
m_i^{ven}	Mass flow rate of supply air to the i^{th} zone
T_i^{sup}	Temperature of supply air to the i^{th} zone
T_i^{des}	Desired temperature for the i^{th} zone
y_i^{est}	Estimated temperature of the i^{th} zone by our state space model

* Corresponding author. Aalborg University, Fredrik Bajersvej 7, Aalborg, 9220, Denmark.
E-mail address: mak@es.aau.dk (M. Khatibi).

<https://doi.org/10.1016/j.job.2022.104100>

Received 8 October 2021; Received in revised form 10 January 2022; Accepted 21 January 2022

Available online 23 January 2022

2352-7102/© 2022 The Authors. Published by Elsevier Ltd. This is an open access article under the CC BY license

(<http://creativecommons.org/licenses/by/4.0/>).

y_i	The temperature of the i^{th} zone derived from IDA ICE
C_{air}	Specific heat capacitance of the air
u_i	Net power delivered to the i^{th} zone
u_i^{int}	Power delivered to the i^{th} zone by internal sources
u_i^{ven}	Power delivered to the i^{th} zone by the air heating and ventilation system

Abbreviations

CAV	constant air volume
HVAC	heating, ventilation, and air conditioning
MPC	model predictive control
MZHV	multi-zone air heating and ventilation
VAV	variable air volume
VRF	variable refrigerant flow
VRV	variable refrigerant volume

1. Introduction

Heating, ventilation, and air conditioning (HVAC) systems are the most energy demanding services in many buildings, using almost half of the final energy in the building sector [1], and account for 10–20% of the total final energy in developed countries [2]. As a result, strong efforts are devoted to develop more efficient and flexible HVAC systems. Migrating to renewable energies has intensified these efforts, since renewable energies are intrinsically unpredictable and their rising share in the power production increases the imbalance between supply and demand. This requires new solutions to attenuate their impact on the stability of the power grid [3]. Activating the energy flexibility of small electricity consumers is among the most promising proposed solutions. For example, residential buildings can provide flexibility services through adjusting the timing and amount of energy used by HVAC systems [4].

There are many types of HVAC systems. Generally, they can be categorized into decentralized and central systems [5]. Decentralized HVAC systems are usually located inside or adjacent a conditioned zone, and there is no requirement for ductwork. Mini-splits and multi-splits (or VRV/VRF systems) are attractive ductless decentralized solutions [6].

In central HVAC systems, on the other hand, the heat is generated in a central location and then distributed throughout the house. Central HVAC systems can be classified into hydronic and forced air systems [7]. Hydronic Systems usually exploit hot water running through the pipes around the building and emit via radiators (or a floor surface) into the intended spaces, whereas forced air systems use hot air as their medium and push it through a duct system into the intended spaces.

There are pros and cons associated with each HVAC solution, depending on the given situation. For example, many decentralized solutions like multi-splits (or VRV/VRF systems) cannot provide any ventilation and thus additional ventilation systems are necessary to be installed. Similarly, considering the hygienic airflow requirements, the maximum supply air temperature is around 50 °C for forced air central HVAC systems. This imposes a limit on their heating power for some applications.

This paper deals specifically with forced air central HVAC systems. These systems are in turn categorized into constant air volume (CAV) and variable air volume (VAV) systems.

As their name implies, the supply airflow rate is constant in CAV systems. In addition, they usually have a centralized heating coil, and thereby push the air at almost identical temperature to all the intended rooms. Such a supply strategy provides little or no possibility to meet individual heating demands in a multi-zone building. Consequently, they are more common in small-sized buildings due to their simplicity and low cost [8]. Such small CAV systems often have on/off control, rather than adjusting supply air temperature, to meet varying heating demands.

VAV systems provide more flexibility than a simple CAV system. Like a CAV system, an identical supply air temperature is delivered to all the zones. In addition, they regulate the supply airflow rate for each zone separately by means of VAV dampers. Since they are capable of regulating the temperature of each zone separately, they are more appropriate for mid-to large-size buildings [9]. Different studies show that VAV systems use considerably less energy compared to the simple CAV systems [10–12]. In addition, the optimal supply air temperature for a VAV system has been investigated in a few papers, which show that the supply air temperature has a considerable effect on energy demand [13,14].

Recently, a novel multi-zone air heating and ventilation (MZHV) system has been developed, which provides even more flexibility than traditional VAV systems. Like a VAV system, it can regulate the supply airflow rate for each zone separately by means of VAV dampers. In addition, it is capable of regulating the supply air temperature for each zone, independently of flow rates. Mechanical operation of the novel MZHV system within a laboratory environment is examined in Refs. [15,16]. The present study is an extension of the preliminary work done in [17]. It investigates the operation and flexibility of the novel MZHV system and compares it with a conventional VAV system. For this purpose, a relatively detailed model of the novel MZHV system is developed in the building simulation environment IDA ICE [18]. In addition, a detailed model of a multi-zone case study building is developed in the same environment.

Rather than relying on traditional rule-based control schemes, a short-term MPC scheme to control real-time power consumption of the multi-zone case study building is developed. MPC controllers predict future events and take control actions accordingly. Some studies show that MPC can reduce energy consumption by up to 17% in comparison with the traditional rule-based control schemes

[19].

An accurate dynamic model of the controlled plant is an essential part of any MPC scheme. For this purpose, a simple second-order state space model with sampling rate of minute order, is identified for each zone of the case study building and then validated against data generated by IDA ICE. Using the second-order models, an MPC controller is developed to control the energy usage of each zone. A local logic layer then determines if the energy dispatched by the MPC layer for each zone shall be supplied as a conventional VAV system through regulating its supply airflow rate, or by regulating its supply air temperature. Finally, local PI controllers regulate the supply airflow rate and supply air temperature for each zone.

The main contributions of this study can be summarized as follows:

- A detailed model of the novel MZHV system, which is capable of manipulating both supply airflow rate and supply air temperature within each zone, is developed in IDA ICE and its operation is compared with conventional VAV systems.
- Two different levels of modeling for a multi-zone building are developed. The first level of modeling is developed in IDA ICE, which is used as a reference. The second one is a decentralized set of simple second-order state-space models with sampling rates at the order of minutes, which are exploited by the MPC layer. The state space models are identified for the case study building based on time series data derived from IDA ICE.
- A short term MPC scheme to control real-time power consumption of a multi-zone building is developed in MATLAB and linked with IDA ICE.

The rest of this paper is organized as follows. Section 2 provides a brief description of the novel MZHV system and its simulation in the IDA ICE environment. Section 3 is devoted to methodology. It discusses the case study building, the proposed models to capture its thermal dynamics and identification procedure. Section 4 presents the proposed control scheme. The co-simulation between MATLAB and IDA ICE and its results are discussed in Section 5. Finally, Section 6 concludes the paper.

2. The novel MZHV system

Fig. 1 shows a sketch of the novel HVAC system. The HVAC system is a balanced mechanical ventilation and air heating system, in which heating is provided via the conditioned air. The system comprises of:

- An Air Handling Unit (AHU) with standard components i.e. supply and exhaust fans, filters and a heat exchanger
- A manifold with a built-in heating coil and heat valves
- Variable Air Volume (VAV) dampers
- A heating unit, e.g. a heat pump
- Supply and extract ductworks

The novelty of the HVAC system is related to the manifold [15,16]. It is a junction box with a built-in heating coil, from which a number of ducts branch off to the ventilated rooms. Each duct is equipped with a so-called heat valve for individual supply air temperature regulation. When air enters the manifold, it may either pass through the heating coil or bypass it. The heat valve of each duct adjusts the percentage of air that passes the heating coil and accordingly regulates the supply air temperature to each room separately (see Fig. 1b). The supply airflow rate to each room can be regulated via adjustment of the VAV damper opening degree associated to that room. At the dwelling level, supply airflow rate and supply air temperature can be regulated via adjustment of the supply fan speed and the supply water temperature to the manifold, respectively.

The ventilated rooms can be equipped with just a supply duct, e.g. in a living room and bedrooms, or with an exhaust duct, e.g. in a bathroom and a utility room, or can be equipped with both a supply and an exhaust duct, e.g. in a kitchen.

The novel MZHV system is modeled in IDA-ICE environment using available components from an existing IDA ICE library [18].

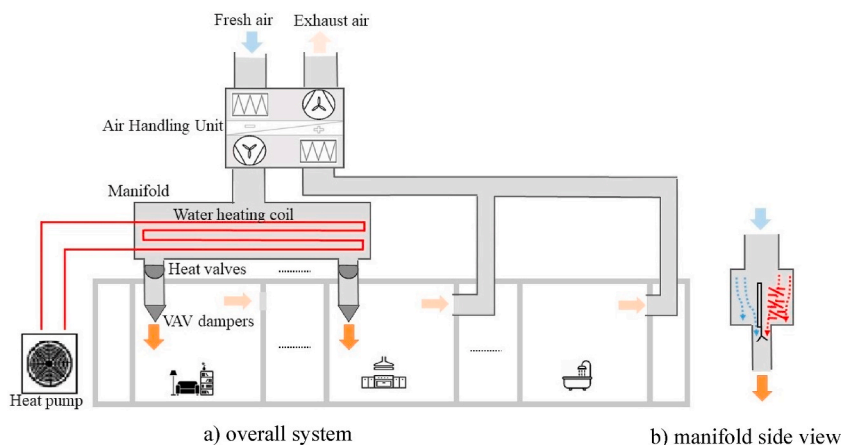

Fig. 1. The novel designed ventilation and air heating system.

Fig. 2 shows a block diagram of the simulation model. Two conventional AHUs from the IDA ICE library are utilized. One of them functions as a heat recovery unit and provides a mild air stream. The second one warms up the mild air and provides a warm air stream. There is an adjustable mixer for each controlled zone that regulates the ratio of mild and warm air streams and consequently sets the supply air temperature. In addition, a conventional VAV adjusts the total airflow of each zone.

3. Methodology

First, this section describes the case study building. Then, two different levels of modeling to capture the thermal dynamics of the case study building are presented. Finally, the identification mechanism is discussed.

3.1. The case study building

Fig. 3 shows the plan of the case study building, which is a typical Danish single-family house as found in a Copenhagen suburb and consists of 11 zones. It is assumed that only 6 zones (Zone 1, Zone 2, Zone 6, Zone 9, Zone 10 and Zone 11) are controlled by the MZHV system. Zone 5, Zone 7 and Zone 8 are only equipped with exhaust ducts, in which a supplementary heating system (e.g. floor heating in the bathroom) can be used to regulate the room temperature.

3.2. Modeling

3.2.1. Modeling in IDA indoor climate and energy (IDA-ICE) software

The first level of modeling is done in IDA ICE, which is used as our “true reference.” A detailed model of the building is developed in IDA ICE using the characteristics indicated in Fig. 3. The effect of internal sources including occupants, equipment and solar irradiation are incorporated in the simulations.

3.2.2. Decentralized state space modeling

For MPC control applications such as coupling MZHV systems with smart-grids, where MZHV system provides ancillary services in a smart electricity grid by responding to external signals (e.g. price signals), there is a need of accurate mathematical models, which are capable of predicting the heat dynamics of a building at zone level. In addition, their time resolution should be high enough, which means sampling rates of once every few minutes at least. Moreover, since they are implemented in real-time, their computational burden should be kept as low as possible. On the other hand, they should be able to deal with real-time uncertainties.

Rather than using a centralized approach, which is known to be computationally demanding [20], a decentralized set of second-order models with sampling rate on the order of minutes is used in the second level. We propose a second order model with a slow and a fast mode for each zone, as follows:

$$x_{1,i}(k+1) = \lambda_{1,i}x_{1,i}(k) + b_{1,i}u_i(k) + l_{1,i}e_i(k) \tag{1}$$

$$x_{2,i}(k+1) = \lambda_{2,i}x_{2,i}(k) + b_{2,i}u_i(k) + l_{2,i}e_i(k) \tag{2}$$

$$y_i^{est}(k) = x_{1,i}(k) + x_{2,i}(k) \tag{3}$$

$$e_i(k) = y_i(k) - y_i^{est}(k) \tag{4}$$

The control input $u_i(k)$ is the average delivered power to the i^{th} zone and the output $y_i(k)$ is the average temperature of the i^{th} zone; $y_i^{est}(k)$ is the temperature of the i^{th} zone estimated by our model.

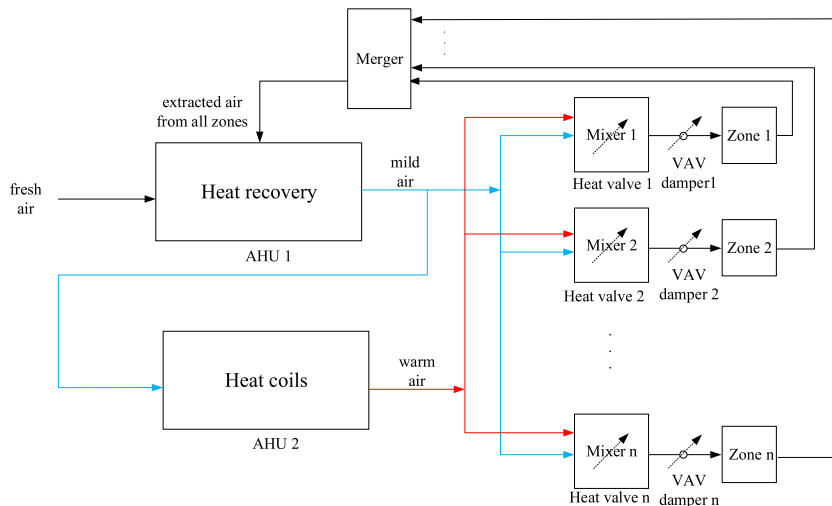
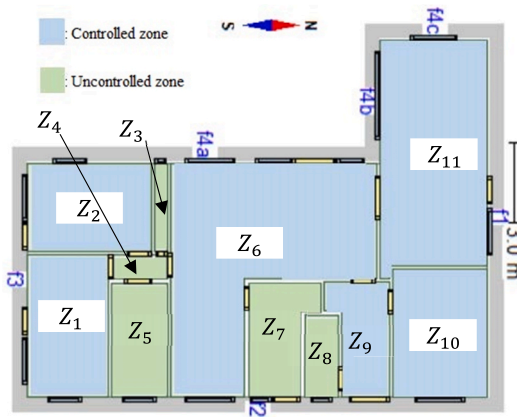

Fig. 2. Block diagram of the model used to simulate the novel MZHV system in IDA ICE environment.



Floor area	160 m ²
Volume	460 m ³
Window/Envelope	6.6%
U-value of external walls	0.4 W/m ² K
U-value of roof	0.2 W/m ² K
U-value of slabs towards the ground	0.3 W/m ² K
U-value of windows	2.9 W/m ² K
U-value of doors	2.9 W/m ² K

Fig. 3. Floor plan of the case study building and its characteristics.

The physical interpretation behind the model is that there are two thermal capacitances in each zone. The fast one corresponds to the heat capacitance of the indoor air and the slow one, which can be considered as a storage media, corresponds to the heat capacitance of the thermal mass (walls, floor, etc.) of the zone [21]. To deal with uncertainties, we use the prediction error as a feedback signal, as is commonly done in a Kalman filter (the popular method for designing observers and state estimators). For prediction purposes, it is assumed $e(k + j) = 0, j > 0$.

3.3. Identification

Since the computational burden of the second-order model is low enough, a 5-min sampling rate is applied. The identification procedure is done in two steps. First, we assume $e_i(k) = 0$ and identify the four parameters $\lambda_{1,i}, \lambda_{2,i}, b_{1,i}, b_{2,i}$ for each zone by exploiting the `sst` command from the *System Identification Toolbox* of MATLAB [22]. Then, the two remaining parameters, i.e. $l_{1,i}$ and $l_{2,i}$, are set by applying Kalman filter design methods [23].

Fig. 4 and Fig. 5 show 1-step-ahead and 12-step-ahead predictions of the zones temperatures by the second-order models for the six controlled zones, respectively, and compare them with the responses of IDA ICE over a one-day simulation period with arbitrary initial and boundary conditions. It is worthy of note that the initial transient responses in the figures, are due to the initial required time for

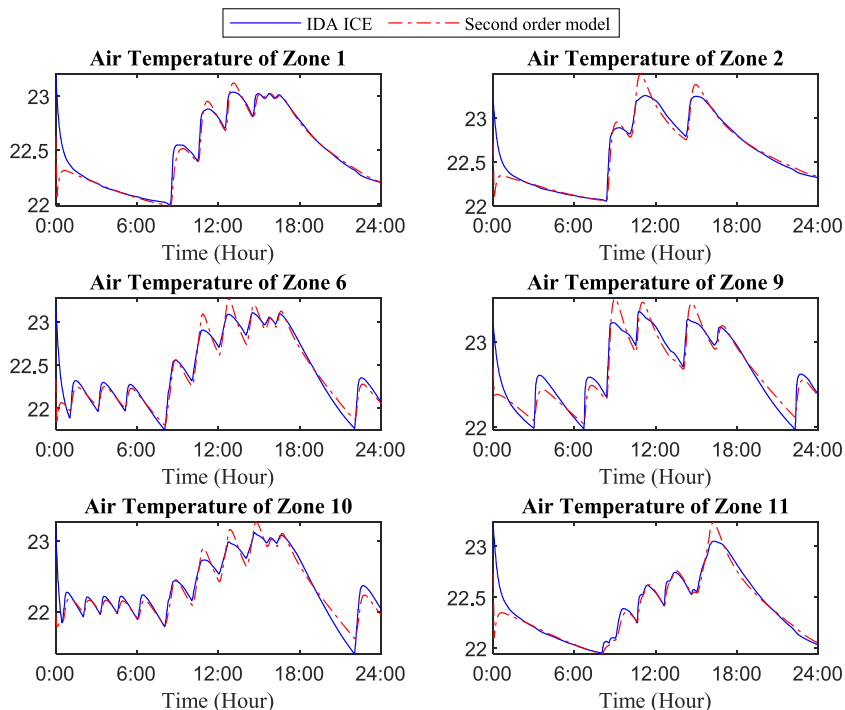

Fig. 4. 1-step ahead prediction by the second order model ($T_s = 5$ min).

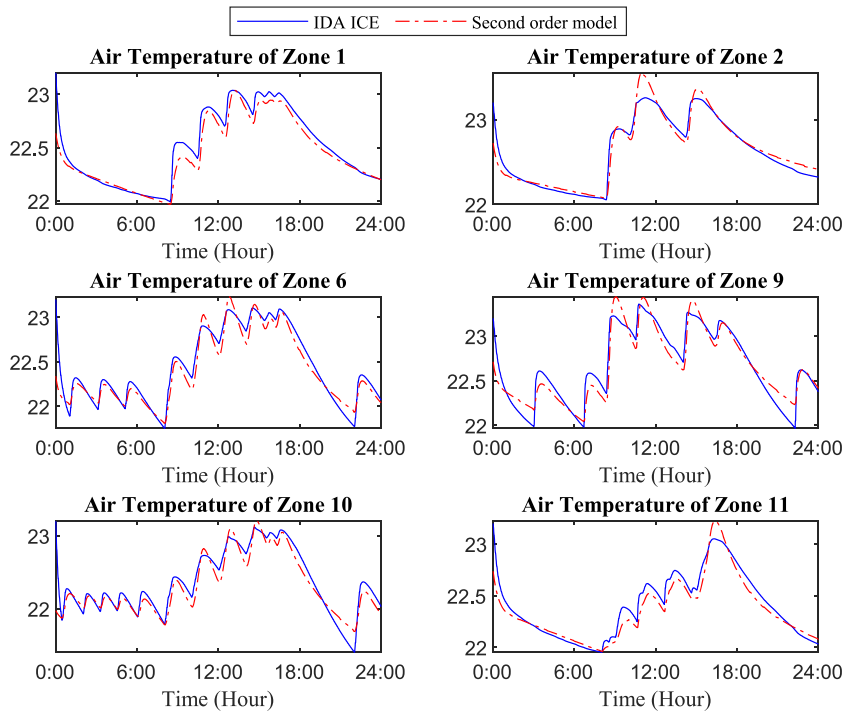

Fig. 5. 12-step ahead prediction by the second order model ($T_s = 5$ min).

the Kalman filter to converge. They only occur when the simulation starts, and can be ignored during normal operation. Thus, we can simply assume the controller starts after this transient period. Overall, due to the Kalman filter feedback, there is a good agreement between the responses of our simple linear second-order models and the data from IDA ICE.

4. Control scheme

Next, we implement a hierarchical control scheme, as described in Fig. 6. It consists of an MPC controller, a local logic layer and local PI controllers. In the following subsections, each layer is described in more details.

4.1. MPC layer

Model predictive control (MPC) has been widely implemented in advanced supervisory control layers [24,25] due to its ability to account for constraints and multi-variable interactions in the dynamics. Thus, it has the ability to optimally control constrained multiple-input multiple-output nonlinear systems.

The MPC layer designed in this study, with 5-min update rate and 1-h prediction horizon, estimates the required energy of each zone, according to the desirable air temperature for the i^{th} zone ($T_i^{\text{des}}(t)$).

Our decentralized set of second-order models are used in this layer for optimization purposes. The following optimization program is executed 12 times each hour (every 5 min) in a receding horizon manner.

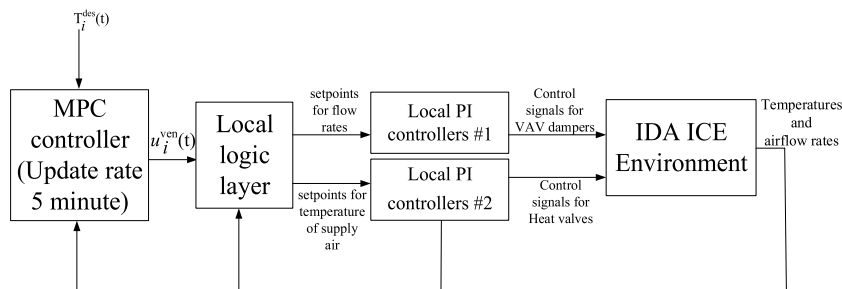

Fig. 6. Hierarchical control scheme.

$$\min_{u_i^{ven}(k+j)} \sum_{i=1}^{N_z} \sum_{j=0}^{11} (T_i^{des}(k+j+1) - y_i^{est}(k+j+1))^2 \quad (5)$$

s.t.

$$u_i(k+j) = u_i^{ven}(k+j) + u_i^{int}(k+j) \quad (6)$$

$$x_{1,i}(k+j+1) = \lambda_{1,i}x_{1,i}(k+j) + b_{1,i}u_i(k+j) + l_{1,i}e_i(k+j), \quad (7)$$

$$x_{2,i}(k+j+1) = \lambda_{2,i}x_{2,i}(k+j) + b_{2,i}u_i(k+j) + l_{2,i}e_i(k+j), \quad (8)$$

$$y_i^{est}(k+j) = x_{1,i}(k+j) + x_{2,i}(k+j), \quad (9)$$

$$e_i(k+j) = \begin{cases} y_i(k) - y_i^{est}(k) & j = 0 \\ 0 & j > 0 \end{cases} \quad (10)$$

$$0 \leq u_i^{ven}(k+j) \leq P_i^{max} \quad (11)$$

where u_i^{int} denotes the thermal power rate of internal sources, including occupants, equipment and light radiations within the i^{th} zone and N_z is the number of zones.

4.2. Control logic layer

As mentioned in the introduction, we compare two different control logic schemes in this research.

The control logic layer, as follows, translates $u_i^{ven}(k)$ into $\dot{m}_i^{ven}(k)$ and $T_i^{sup}(k)$ according to the control logic and then sends them to the local PI controllers. The output of this layer is the reference set points for the local PI controllers to regulate the supply air temperature and supply airflow rate.

4.2.1. Conventional VAV logic for MZHV systems

In this approach, the supply air temperature is fixed and the rate of delivered energy to each zone is controlled by manipulating the supply airflow rate to each zone. So, we set

$$T_i^{sup}(k) = T^{sup} \quad (12)$$

$$\dot{m}_i^{ven}(k) = \frac{u_i^{ven}(k)}{C_{air}(T^{sup} - y_i(k))} \quad (13)$$

If $\dot{m}_i^{ven}(k)$ is outside its minimum or maximum level, we set it to its saturation limit.

4.2.2. Minimum airflow rate (The novel MZHV system)

In the novel MZHV system, we can manipulate both the supply air temperature and supply airflow rate to control the delivered energy. To reduce the system's acoustic noise, we base the local regulation on keeping a minimum airflow rate in each zone. For this purpose, we set

$$\dot{m}_i^{ven}(k) = \dot{m}_i^{ven} \quad (14)$$

$$T_i^{sup}(k) = \frac{u_i^{ven}(k)}{C_{air}\dot{m}_i^{ven}} + y_i(k) \quad (15)$$

If $T_i^{sup}(k)$ is outside its min or max level, we set it to its saturation limit.

4.3. Local PI controllers

There are two sets of local PI controllers in this scheme. A local PI controller per VAV damper regulates it to keep the supply airflow

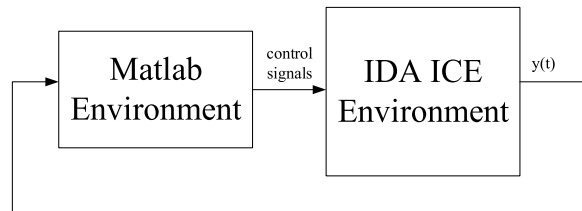

Fig. 7. Co-simulation between MATLAB and IDA ICE

rate around its desired value. In addition, one local PI controller per heat valve regulates it to keep the supply air temperature around its desired value.

5. Results and discussion

We run two co-simulations involving MATLAB (control) and IDA ICE (building and HVAC simulation) to compare the two control logic schemes (Fig. 7). The two investigated scenarios are represented in Table 1.

In the first scenario, which represents a conventional VAV system, the supply air temperature is kept constant around 30 °C and the supply airflow rate is manipulated within each zone to follow the reference temperatures. At the second scenario, the supply airflow rate is kept at the minimum level of $0.3 \frac{L}{sm^2}$ for each zone and the supply air temperature is manipulated within each zone to follow the references.

Remark. Except for the local logic layer, all other settings, including the MPC layer, are identical in the two co-simulations. Consequently, any observed improvement will be due to the difference in the local logic layer, i.e. manipulating supply air temperature instead of supply airflow rate. Comparing the proposed MPC scheme with traditional rule-based control schemes is beyond the scope of this paper.

The simulations are done for a whole day, i.e. 24 h, in early January. It is assumed we have a perfect knowledge about the delivered energy from internal sources, including occupants, lighting, solar irradiation, as well as in-house equipment (See Table 2).

Fig. 8 shows the response of the six controlled zones in the two scenarios. We define two indexes for the purpose of comparison. To quantify the comfort level, we define the mean absolute difference between the reference and simulated temperature responses as an index for the comfort level and denote it as “mean absolute error”. Another index is the mean delivered power to each zone by the MZHV system. Table 1 compares the performance and power consumption in both scenarios for the 6 zones which we have control over.

According to Table 2, the second scenario, in which the supply air temperature is regulated instead of the supply airflow rate, reduces the mean absolute error from 0.95 to 0.65, which shows that the reference signals can be tracked more precisely, and therefore a better comfort level is achieved. In addition, the novel MZHV system lowers average power consumption from about 1 kW to less than 0.8 kW (indicating more than 20% energy saving). It is worthy to mention that the novel MZHV system can operate as a traditional VAV system and manipulate only supply airflow rates (the first scenario) as well. In addition, it is capable of manipulating the temperature of supply air for each zone separately (the second scenario). So, it can be considered as a flexible load which can deliver roughly the same comfort level at lower energy use. Moreover, it should be emphasized that there is a cost-flexibility tradeoff. If the system is adjusted to minimize power consumption and therefore the energy cost, the only flexibility is to increase power consumption when it is needed by the grid. However, it is possible to adjust the system consumption, slightly above the minimum level. It will increase the total energy cost, but in turn provide more flexibility. In this case, the system will be capable of both increasing and decreasing its power consumption according to the grid’s condition and thus contribute to balance the electricity network in a smart-grid setting without compromising the comfort levels. How this extra flexibility can be utilized in an efficient way in order to balance a smart grid, is the subject of future research.

6. Conclusion

There are two approaches to control the temperature of each zone within a multi-zone building by forced air heating systems: regulating the supply airflow rate and regulating the supply air temperature. Recently, a novel MZHV system has been developed, which is characterized by regulating both the supply airflow rate and the supply air temperature to the rooms, independently of each other. The performance of the novel MZHV system is investigated in this paper and compared with conventional VAV systems, which usually maintain the supply air temperature constant within all rooms and regulate only the supply airflow rate to the rooms. For this purpose, the MZHV system as well as a multi-zone building are modeled in the IDA ICE environment. For control purposes, a simple second order state-space model for each zone is identified and validated against the results from IDA ICE simulations. Then a model predictive control (MPC) scheme is developed and implemented in MATLAB environment. The communication between MATLAB and IDA ICE is established and two co-simulations (MATLAB and IDA ICE) are performed to compare the performance of the novel MZHV system with the conventional VAV systems. Two indexes were defined for the purpose of comparison. The mean absolute difference between the reference and simulated responses is considered as an index for the comfort level. Another index is the average delivered power to each zone by the MZHV system. The results show that the novel MZHV system is not only able to track the reference signal better (improving mean absolute error by almost 30%), but also decreases the energy use considerably (more than 20%). The flexibility can be exploited to reduce the power consumption or balance the electricity network in a smart grid. It will be the subject of future research.

Author statement

Mahmood Khatibi: Conceptualization, Methodology, Software, Investigation, Formal analysis, Writing original draft, Review & editing.

Samira Rahnama: Conceptualization, Methodology, Software, Funding acquisition, Writing Section 2, Review & editing.

Pierre Vogler-Finck: Conceptualization, Methodology, Review & editing.

Jan Dimon Bendtsen: Conceptualization, Methodology, Review & editing, Supervision.

Alireza Afshari: Conceptualization, Methodology, Review & editing, Funding acquisition, Project administration.

Table 1
The two investigated scenarios.

	Supply airflow rate	Supply air temperature
Scenario 1 (Conventional VAV systems)	variable	30 °C
Scenario 2 (Minimum airflow rate, the novel MZHV system)	$0.3 \frac{L}{sm^2}$	variable

Table 2
Comparison the performance and power consumption in the both scenarios.

	Mean power of internal sources (W)	The first scenario		The second scenario	
		mean absolute error (°C)	mean delivered power by VAV system (W)	mean absolute error (°C)	mean delivered power by MZHV system (W)
Zone 1	281	0.21	69	0.12	48
Zone 2	281	0.24	62	0.15	42
Zone 6	281	0.06	312	0.06	257
Zone 9	106	0.18	69	0.11	53
Zone 10	281	0.07	418	0.1	329
Zone 11	181	0.19	78	0.11	57
Sum	1411	0.95	1008	0.65	786

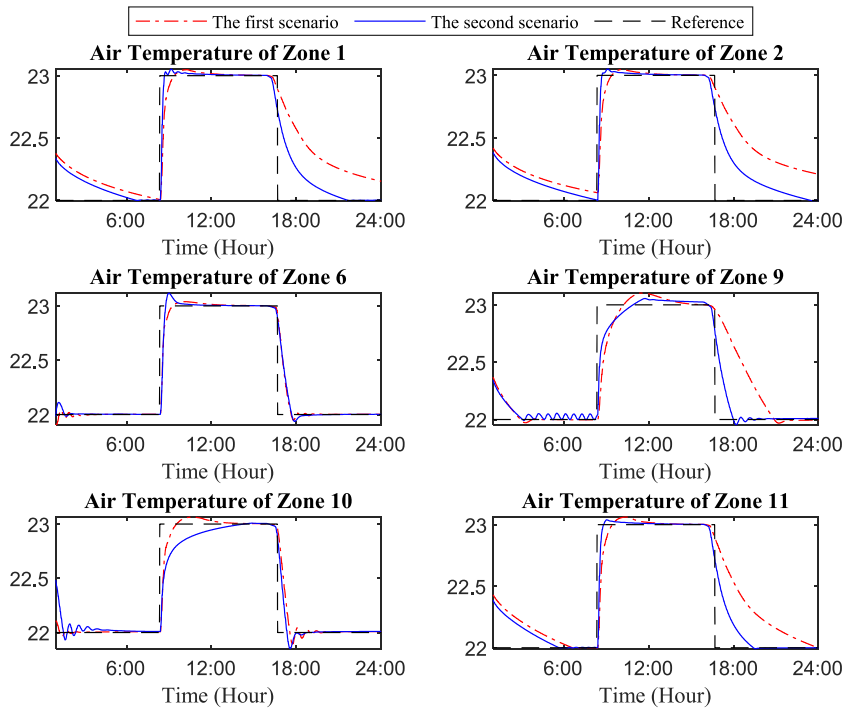

Fig. 8. The response of the first zone for the two scenarios.

Declaration of competing interest

The authors declare that they have no known competing financial interests or personal relationships that could have appeared to influence the work reported in this paper.

Acknowledgement

This paper was sponsored in part by EUDP project “Ancillary services in Smart Grid using multi-zone demand-controlled residential ventilation systems (SmartVENT)” (Journal No. 64018-0501).

References

- [1] A. Viswambharan, S.K. Patidar, K. Saxena, Sustainable HVAC systems in commercial and residential buildings, *Int. J. Sci. Res. Publ.* 4 (2014) 1–4.
- [2] G. Jing, W. Cai, X. Zhang, C. Cui, X. Yin, H. Xian, An energy-saving oriented air balancing strategy for multi-zone demand-controlled ventilation system, *Energy* 172 (2019) 1053–1065.
- [3] M. Khatibi, J.D. Bendtsen, J. Stoustrup, T. Mølbak, Exploiting power-to-heat assets in district heating networks to regulate electric power network, *IEEE Trans. Smart Grid* 12 (3) (2020) 2048–2059.
- [4] M.H. Christensen, R. Li, P. Pinson, Demand side management of heat in smart homes: living-lab experiments, *Energy* 195 (2020) 116993.
- [5] S. Seyam, Types of HVAC Systems, *HVAC System*, 2018, pp. 49–66, <https://doi.org/10.5772/intechopen.78942>.
- [6] T.N. Aynur, Y. Hwang, R. Radermacher, Simulation comparison of VAV and VRF air conditioning systems in an existing building for the cooling season, *Energy Build.* 41 (11) (2009) 1143–1150.
- [7] B. Kulmedov, S. Durdyev, Cost and environmental performance of forced air and hot water heating systems in post-Soviet countries, *Int. J. Build. Pathol. Adapt.* (2021), <https://doi.org/10.1108/IJBPA-05-2021-0069>. In press.
- [8] J. Gao, X. Xu, X. Li, J. Zhang, Y. Zhang, G. Wei, Model-based space temperature cascade control for constant air volume air-conditioning system, *Build. Environ.* 145 (2018) 308–318.
- [9] G.S. Okochi, Y. Yao, A review of recent developments and technological advancements of variable-air-volume (VAV) air-conditioning systems, *Renew. Sustain. Energy Rev.* 59 (2016) 784–817.
- [10] A. Ameen, K. Mahmud, Energy performances of prototype VAV and CAV systems under simulated humid tropical climates, *Build. Eng.* 111 (1) (2005).
- [11] S. Kalaiselvam, S.V. Vidhya, S. Iniyan, A.A. Samuel, Comparative energy analysis of a constant air volume (CAV) system and a variable air volume (VAV) system for a software laboratory, *Int. J. Vent.* 5 (2) (2006) 229–237.
- [12] D.B. Lu, D.M. Warsinger, Energy savings of retrofitting residential buildings with variable air volume systems across different climates, *J. Build. Eng.* 30 (2020) 101223.
- [13] Y.P. Ke, S.A. Mumma, Optimized supply-air temperature (SAT) in variable-air-volume (VAV) systems, *Energy* 22 (6) (1997) 601–614.
- [14] F. Engdahl, D. Johansson, Optimal supply air temperature with respect to energy use in a variable air volume system, *Energy Build.* 36 (3) (2004) 205–218.
- [15] J. Polak, K. Rupnik, A. Afshari, N.C. Bergsøe, G. Hultmark, July. Development of a novel temperature-based demand controlled ventilation system for residential buildings, in: *Indoor Air 2018: the 15th Conference of the International Society of Indoor Air Quality & Climate (ISIAQ)*, ISIAQ, 2018.
- [16] J. Polak, A. Afshari, P. Sadeghian, C. Wang, S. Sadrizadeh, Improving the performance of heat valve ventilation system: a study on the provided thermal environment, *Build. Environ.* 164 (2019) 106338.
- [17] S. Rahnama, P. Vogler-Finck, G. Hultmark, K. Rupnik, A. Afshari, November. Energy flexibility of residential buildings using a novel multi-zone demand controlled ventilation and heating system, in: *16th Conference of the International Society of Indoor Air Quality and Climate: Creative and Smart Solutions for Better Built Environments, Indoor Air 2020, International Society of Indoor Air Quality and Climate*, 2020. ABS-0279.
- [18] T. Kalamees, *IDA ICE: the simulation tool for making the whole building energy and HAM analysis*, Annex 41 (2004) 12–14.
- [19] F. Mtibaa, K.K. Nguyen, V. Dermardiros, M. Cheriet, Context-aware model predictive control framework for multi-zone buildings, *J. Build. Eng.* 42 (2021) 102340.
- [20] E. Atam, Decentralized thermal modeling of multi-zone buildings for control applications and investigation of sub modeling error propagation, *Energy Build.* 126 (2016) 384–395.
- [21] R.E. Hedegaard, M.H. Kristensen, T.H. Pedersen, A. Brun, S. Petersen, Bottom-up modelling methodology for urban-scale analysis of residential space heating demand response, *Appl. Energy* 242 (2019) 181–204.
- [22] MATLAB and System Identification Toolbox R2018b: User's Guide, The MathWorks, Inc., Natick, MA, USA, 2018.
- [23] L. Wang, *Model Predictive Control System Design and Implementation Using MATLAB®*, Springer Science & Business Media, 2009.
- [24] D. Mariano-Hernández, L. Hernández-Callejo, A. Zorita-Lamadrid, O. Duque-Pérez, F.S. García, A review of strategies for building energy management system: model predictive control, demand side management, optimization, and fault detect & diagnosis, *J. Build. Eng.* 33 (2021) 101692.
- [25] F. Isaia, M. Fiorentini, V. Serra, A. Capozzoli, Enhancing energy efficiency and comfort in buildings through model predictive control for dynamic façades with electrochromic glazing, *J. Build. Eng.* 43 (2021) 102535.