



AALBORG UNIVERSITY
DENMARK

Aalborg Universitet

An Energy Recovery Scheme for RCD Snubber in the Series Configuration of IGBTs

Zarghani, Mostafa ; Peyghami, Saeed; Iannuzzo, Francesco; Blaabjerg, Frede; Kaboli, Shahriyar

Published in:
2021 IEEE Energy Conversion Congress and Exposition (ECCE)

DOI (link to publication from Publisher):
[10.1109/ECCE47101.2021.9595162](https://doi.org/10.1109/ECCE47101.2021.9595162)

Publication date:
2021

Document Version
Accepted author manuscript, peer reviewed version

[Link to publication from Aalborg University](#)

Citation for published version (APA):
Zarghani, M., Peyghami, S., Iannuzzo, F., Blaabjerg, F., & Kaboli, S. (2021). An Energy Recovery Scheme for RCD Snubber in the Series Configuration of IGBTs. In *2021 IEEE Energy Conversion Congress and Exposition (ECCE)* (pp. 5183-5189) <https://doi.org/10.1109/ECCE47101.2021.9595162>

General rights

Copyright and moral rights for the publications made accessible in the public portal are retained by the authors and/or other copyright owners and it is a condition of accessing publications that users recognise and abide by the legal requirements associated with these rights.

- Users may download and print one copy of any publication from the public portal for the purpose of private study or research.
- You may not further distribute the material or use it for any profit-making activity or commercial gain
- You may freely distribute the URL identifying the publication in the public portal -

Take down policy

If you believe that this document breaches copyright please contact us at vbn@aub.aau.dk providing details, and we will remove access to the work immediately and investigate your claim.

An Energy Recovery Scheme for RCD Snubber in the Series Configuration of IGBTs

Mostafa Zarghani

Department of Electrical Engineering
Sharif University of Technology
Tehran, Iran
Mostafa.Zarghani@gmail.com

Saeed Peyghami

Department of Energy Technology
Aalborg University
Aalborg, Denmark
sap@et.aau.dk

Francesco Iannuzzo

Department of Energy Technology
Aalborg University
Aalborg, Denmark
fia@et.aau.dk

Frede Blaabjerg

Department of Energy Technology
Aalborg University
Aalborg, Denmark
fbl@et.aau.dk

Shahriyar Kaboli

Department of Electrical Engineering
Sharif University of Technology
Tehran, Iran
kaboli@sharif.ir

Abstract— This paper presents an energy recovery scheme for traditional Resistor-Capacitor-Diode (RCD) snubber in the series-connected configuration of IGBTs. In the series configuration of IGBTs, an RCD snubber is used in parallel to each IGBT to provide a safe operating condition for the IGBTs. In the proposed scheme, by using interconnection diodes, the capacitors of the snubbers are parallelized in the on-state of the IGBTs. Thus, the stored energies in the snubber capacitors are lumped together and transferred to the DC link by using a transformer and a resonant circuit. By using of the proposed method, the capacitor of the snubber can have a higher value. Higher value of the snubber capacitance improve voltage sharing of the IGBTs and reduce the turn-off switching power losses of the IGBTs. The proposed scheme is simulated for a case study using PSPICE software and tested through an experimental setup. Simulation and experimental results imply the proper performance of the proposed scheme.

Keywords—Series connected IGBTs, RCD snubber, energy recovery

I. INTRODUCTION

Employing series-connected switches is one of the practical solution for high voltage applications, such as high voltage motor drives [1], [2], solid-state circuit breakers, high voltage DC transmission systems [3]–[6], and solid-state modulators [7], [8]. Insulated-gate bipolar transistor (IGBTs) are an attractive choice for the switch because of its high current capacity. However, the unbalanced voltage sharing among series connected switches is the most critical issue. This issue arises from various sources including mismatches in the electrical characteristics of IGBTs, differences in IGBT junction temperature, differences in the driver components, time delay in command signal of drivers and the parasitic capacitance of the IGBTs and their driver circuits [9], [10]. In the series structure of the switches, since the thermal resistance of the switches is not the same, high power loss in switches causes different junction temperatures of each switch. Different junction temperatures will cause different switching characteristics of the switches. It leads to unbalanced voltage sharing of the IGBTs, although the gate

driver signals are exactly synchronized. Also, in these applications, since the IGBTs and their corresponding snubbers are at different high voltage potentials, the cooling system has some difficulties.

Different approaches are proposed for voltage balancing of series-connected IGBTs in the literatures. These approaches can be categorized into two main groups. The first group which is called active methods focus on the gate side of the IGBTs. The main subgroups of active methods are active clamp methods [11]–[12], active gate control methods [13]–[14] and gate delay adjusting methods [15]. However, extra power loss of the series IGBTs in a probable overvoltage situation [13], difficulty in implementation with a large number of devices, a relatively slow speed to balance the voltage of series IGBTs [16] are the main shortcomings of this group. The second group relies on passive methods, where external circuits are connected in parallel to the collector-emitter of IGBTs in order to prevent the overvoltage of switches [7]. In comparison with the active methods, passive methods are easy to implement and can be extended to large number of switches. The external circuits are mainly traditional RCD snubbers or clamp mode snubbers. The clamp mode snubbers just limit the voltage of the IGBTs, without affecting the switching characteristic of the them [10]. However, traditional RCD snubbers effect on switching characteristic of the switches in turn-off transition, and improve voltage balancing of the series IGBTs. Furthermore, RCD snubbers reduce switching power losses of the IGBTs [17], improve the reliability [18], reduce EMI issues [19], and suppress transient voltage and current spikes [20]. In the traditional scheme for series configuration of switches, one RCD snubber is used for each IGBT [21], [25], and the stored energy in each capacitor is dissipated in the corresponding resistor in the snubber. Increasing the capacitance of the snubbers reduces turn-off switching losses [17] and improves voltage balancing of the series IGBTs [22]. On the other hand, the performance of the RCD snubber is associated with the power dissipation. The RCD snubber decreases the switching power loss of IGBTs, while this power loss is actually transferred to the snubber to be dissipated.

In order to reduce the power loss of the RCD snubber, energy recovery schemes in single switches have been presented in the [23]–[26]. Using these schemes for series IGBTs needs isolated converter for each snubber of the switches. Also by using a concentrated snubber, a regenerative scheme for reducing the power loss of the clamp mode snubbers in series connected IGBTs is used in [7] and [10]. The used converter in [7] and [10], just limits the voltage of the snubbers and it does not completely discharge the snubber capacitors.

In order to address this issue, instead of dissipating the stored energies in the resistors, this paper proposes a new scheme for energy recovery of RCD snubbers in the series configuration of IGBTs. In the proposed scheme the capacitors of the snubbers will be connected in parallel by means of interconnection diodes in the on-state of IGBTs. Therefore, the stored energy in the snubber capacitor of each switch will be transferred to a converter, which is used to transfer the stored energy of the snubber capacitors to the main DC link.

In the following, the proposed energy recovery scheme is presented in Section II. The design process of the key components of the proposed scheme is discussed in Section III. In section IV the power loss of the proposed scheme is calculated and compared with traditional RCD snubber. Sections V and IV validate the effectiveness of the proposed scheme by simulations and experimental results. Finally, the outcomes are provided in Section VI.

II. PROPOSED ENERGY RECOVERY SCHEME

The series-connected configuration of IGBTs with traditional RCD snubbers is depicted in Fig. 1. When the IGBTs turn from the off-state to the on-state, the diodes (D_s) are reversed biased, and the stored energies in the capacitors are dissipated in the resistors. The proposed scheme for recovering the energy of RCD snubbers in the series configuration of IGBTs is depicted in Fig. 2. In the proposed scheme, when the IGBTs turn from the on-state to the off-state, the snubber capacitors become in parallel with the IGBTs by the use of snubber diodes (D_s), as depicted in Fig. 3 (a). When the IGBTs turn from the off-state to the on-state, the stored energies in the capacitors are transferred to the transformer by the use of the IGBTs and the interconnected diodes (D_i) as depicted in Fig. 3 (b), and the transformer transfers the stored energy in the capacitors to the DC link.

In this circuit, the turn ratio of the transformer is $2n$ ($\frac{N_2}{N_1} = 2n$), where n is the number of the IGBTs. Thus, the equivalent circuit of the snubbers in the on-state of the IGBTs will be as depicted in Fig. 4. The initial voltages of the snubber capacitors are $\frac{V_{DC}}{n}$ in the on-state of IGBTs. Therefore, the voltage of the capacitors (V_C) and the current of the inductor (I_{L_r}) will be as (1) and (2), respectively.

$$\begin{cases} V_C = \frac{V_{dc}}{2n}(1 + \cos \omega t) & 0 \leq \omega t \leq \pi \\ V_C = 0 & \pi \leq t \end{cases} \quad (1)$$

$$\begin{cases} I_{L_r} = \frac{V_{dc}}{2} \sqrt{\frac{C}{nL_r}} \sin \omega t & 0 \leq \omega t \leq \pi \\ I_{L_r} = 0 & \pi \leq t \end{cases} \quad (2)$$

In these equations, ω is as given in (3)

$$\omega = \frac{1}{\sqrt{\frac{1}{4n} L_r C}} \quad (3)$$

The current of the inductor and the voltage of snubber capacitors will be equal to zero after $t = \pi \sqrt{\frac{1}{4n} L_r C}$. Thus, in order to transfer the stored energy of capacitors to the DC link, the minimum on-time of the IGBTs in each switching period must be higher than this value.

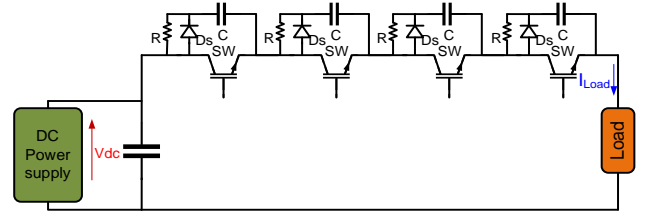

Fig. 1. Series configuration of IGBTs with traditional RCD.

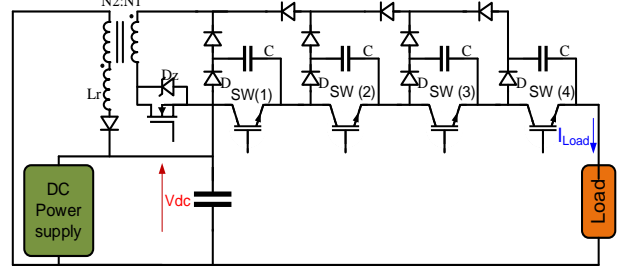

Fig. 2. Series configuration of IGBTs with the proposed recovering energy scheme.

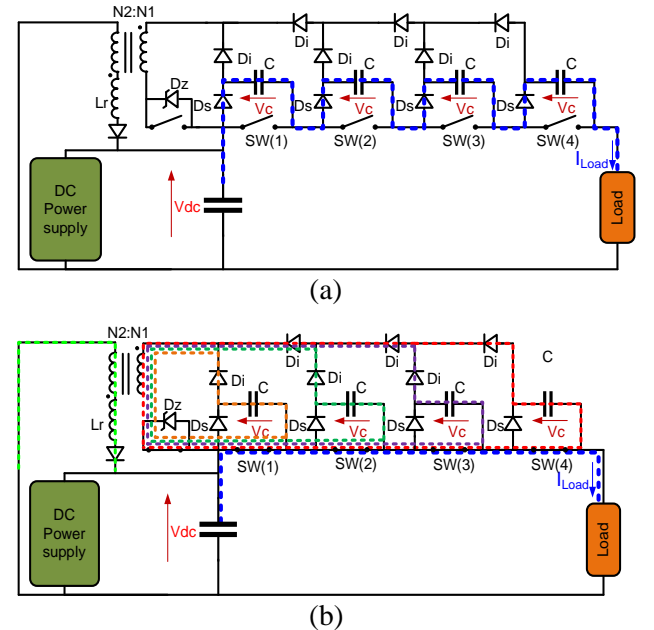

Fig. 3. Proposed scheme for recovering energy from snubbers a) during on-state of IGBTs b) during off-state of IGBTs.

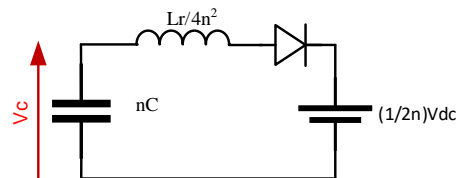

Fig. 4. Equivalent circuit of the proposed scheme when IGBTs are in the on-state.

As shown in Fig. 3 (b), when the IGBTs are in the turn-on state, in addition to the load current, the currents of the snubber capacitors pass through the IGBTs. The current that passes through each IGBT is dependent on how many snubbers are after that IGBT. The current of the i^{th} IGBT ($I_{sw(i)}$) is as given in (4).

$$I_{sw(i)} = I_{Load} + 2(n - i + 1)I_{L_r} \quad (4)$$

This means that the first IGBT that is closer to the recovery circuit has the maximum current value, and the last IGBT that is closer to the load has the minimum current value.

III. DESIGNING THE KEY COMPONENTS

In this approach, the value of the snubber capacitance can be selected for maximum voltage sharing [22], minimum power loss of switches [17], maximum lifetime of switches [18], minimum Electromagnetic Interference (EMI) [19], and etc. Electromagnetic Interference (EMI) [19], and etc. In the turn-on and turn-off transition of the series-connected IGBTs, the injected electrical charge to the snubbers is not equal because of nonsynchronous operation of the IGBTs. Therefore, the voltage of the IGBTs will be unbalanced. If an IGBT have a time delay of Δt_{delay} in the turn-on or in the turn-off transition, the overvoltage (ΔV_{Max}) of the IGBT can be obtained by (5).

$$\Delta V_{Max} = \frac{I_{Load} \Delta t_{delay}}{C} \quad (5)$$

Thus, the snubber capacitance value can be obtained by (6) in order to limit the IGBT voltage.

$$C \geq \frac{I_{Load} \Delta t_{delay}}{\Delta V_{Max}} \quad (6)$$

Based on the selected value for the snubber capacitance and the minimum turn-on time of the switches ($t_{on,min}$) the inductor value can be defined as given in (7).

$$L_r \leq \frac{4n\pi^2 t_{on,min}^2}{C} \quad (7)$$

By using equations (2), (3) and (4), the maximum current of the switches (I_{sw-Max}) can be obtained as given in (8).

$$I_{sw-Max} = 2nV_{dc} \sqrt{\frac{nC}{L_r}} + I_{Load} \quad (8)$$

It should be considered that the maximum current of the switches must be in the safe operating area ($I_{SOA-Max}$). Therefore, the minimum value of inductor can be obtained by (9).

$$L_r \geq \frac{4n^3 V_{dc}^2 C}{(I_{sw-Max} - I_{Load})^2} \quad (9)$$

In order to completely discharging the capacitors of the snubbers in the turn-on state of the IGBTs, the turn ratio of the transformer must be $2n$. The parasitic inductor of the transformer is in series with L_r . Thus, the value of L_r should be corrected considering the value of the parasitic inductor of the transformer. In the recovery circuit, the zener diode (Dz) is paralleled to the IGBT to limit the

voltage of the switch and reset the magnetic core of the transformer.

IV. COMPARATIVE STUDY

The proposed method ideally should recover all the stored energies in the capacitors of the snubbers. As discussed, the energy recovery scheme is realized by interconnection diodes, IGBTs and transformer. However, the nonidealities of the components cause to dissipation of an amount of this energy. The aim of this section is to calculate this power loss. Subsequently, this section compares the result of the proposed method in terms of the power dissipation with the traditional RCD snubber illustrated in Fig. 1. As illustrated in Fig. 5, these components are not ideal and exhibit voltage drop. The power dissipated in the interconnection diodes and the IGBTs can be calculated as follows. In the turn-on state of the IGBTs, the electrical charge in the snubber capacitor of the i^{th} IGBT ($Q_{C(i)}$), except the last IGBT, transfers through the interconnection diodes and the IGBTs to the primary winding of the transformer. It means that $Q_{C(i)}$ flow through the i diodes and $(i+1)$ IGBTs. The electrical charge of the snubber capacitor of the last IGBT ($Q_{C(n)}$) flow through the $(n-1)$ diodes and $(n+1)$ IGBTs. In the secondary side of the transformer the electrical charge which is divided by the transformer winding ratio ($\frac{N_2}{N_1} = 2n$) flow through n diode. Therefore, the total dissipated energy relevant to recovery circuit ($E_{loss-recovery}$), in each switching cycle can be calculated by (10).

$$E_{loss-recovery} = \left(\sum_{i=1}^n (Q_{C(i)} \cdot (i \cdot V_F + (i+1) \cdot V_{sat} + V_F) - Q_{C(n)} \cdot V_F) \right) \quad (10)$$

In this equation V_F is the voltage drop of the diode, V_{sat} is the turn-on voltage of the IGBTs, and $Q_{C(i)}$ is equal to (11)

$$Q_{C(i)} = \frac{V_{dc}}{n} C \quad (11)$$

Therefore, equation (10) can be rewritten as the equation given in (12).

$$E_{loss-recovery} = \frac{V_{dc}}{n} \cdot C \cdot \left(\left(\frac{n \cdot (n+1)}{2} + n - 1 \right) \cdot V_F + \left(\frac{n \cdot (n+1)}{2} + n \right) \cdot V_{sat} \right) \quad (12)$$

In the traditional RCD snubbers of series connected IGBTs, all of the stored energies in the capacitors dissipate in the resistor, and the series IGBTs can be obtained by (13).

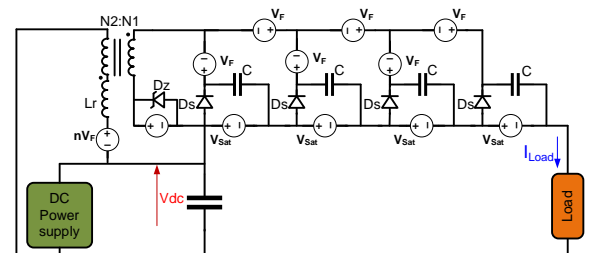

Fig. 5. Illustrative representing of the voltage drops of diodes and IGBTs

Table I. Parameters of the simulated circuit.

V_{sat} (Saturation voltage of IGBTs)	2.4 V
C_s (Snubber capacitors)	20 nF
V_F (Forward voltage drop of diodes)	1.8 V
V_{dc} (DC link voltage)	2400 V
Number of series IGBTs	4

$$E_{Loss-traditional} = \frac{V_{dc}^2}{2n} \cdot C \quad (13)$$

For a case study in Table I, in each switching cycle, the total dissipated energy for the conventional snubber is 14.4 mJ, and for the proposed scheme is 0.7 mJ.

V. SIMULATION RESULTS

A case study with four series-connected IGBTs is assumed for simulation. In Table II, the parameters of the simulated circuit are summarized. Fig. 6 shows the voltage waveforms of the snubber capacitors and the current of the inductor. In Fig. 6, it can be seen that the voltage of the capacitors decreased to almost zero after 4.5 μ s. Using the numbers in Table I, the total stored energy in the capacitors of the snubbers in each switching cycle is 14.4 mJ. As shown in Fig. 6, the maximum injected current to the DC link is 2.13 A. Thus, the total injected energy to DC link in each switching cycle is 13.5 mJ, and 0.9 mJ is dissipated in IGBTs, interconnection diodes, transformer, and inductor. In Fig. 7, the voltage and the current of the IGBTs in the on-state of the IGBTs are presented. As shown in Fig. 7 the current in the first snubber capacitor just passes through the first IGBT, but the current of the last snubber capacitor passes through all of the IGBTs. Thus, as shown in Fig. 7 when the IGBTs are in the turn-on state, the currents waveforms of IGBTs are different firstly, and after discharging the snubber capacitors, the current of the IGBTs will be equal. In Fig. 8 the voltages of capacitors and the voltage of the switches are illustrated. In the turn-off transition the capacitors of the snubber become parallel with the switches. Therefore as shown in Fig. 8 the voltages of the switches are equal to the voltages of the capacitors.

In the real condition, the characteristics of the IGBTs and the drivers are not the same. Also, the input command signals may have some delays to each other. Therefore, the turn-on and turn-off transitions of the IGBTs are not completely synchronized. In order to consider the effect of uncertainties on the operation of the proposed method, it is assumed one of the IGBTs is turned on 30ns after other IGBTs, and one of the IGBTs is turned off 50 ns before other IGBTs. In Fig. 9, the voltages of the IGBTs and the snubbers considering these assumptions are shown.

Table II. Parameters of the simulated circuit.

L_r (Series inductor)	1.3 mH
C_s (Snubbers' capacitors)	20 nF
I_{Load} (Load current)	35 A
V_{dc} (DC link voltage)	2400 V
IGBT part number	IKW40N120H3
Diode part number	UF5408

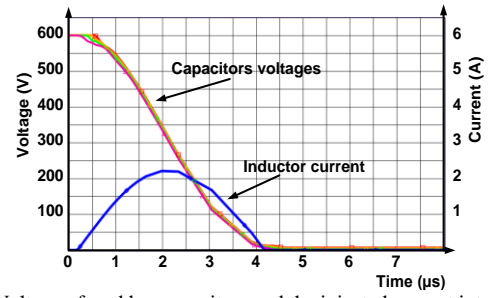

Fig. 6. Voltage of snubber capacitors and the injected current into DC link when the IGBTs are in the turn-on state.

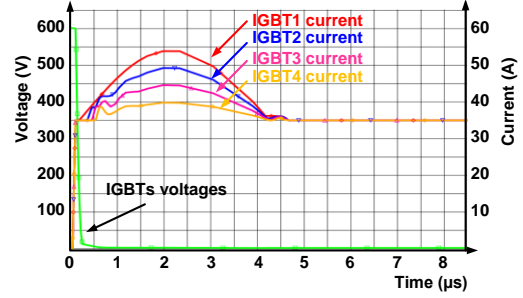

Fig. 7. IGBTs currents and voltages when the IGBTs are in the turn-on state.

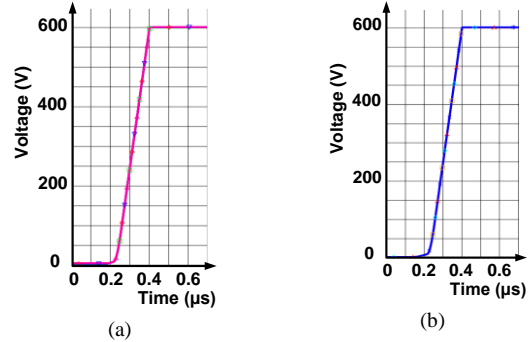

Fig. 8. a) Voltage of capacitors of the snubbers, and b) Voltage of IGBTs when the IGBTs are in the turn-off transition.

As shown in Fig. 9, the overvoltage of the IGBTs is restricted. Also, after the turn-on transition, the voltage of the capacitor of the snubber, which has the maximum voltage, start to decrease at first. After the voltage of it reaches the voltage of the next capacitor, which has the next maximum voltage, the volage of second capacitor also starts to decrease. In the same way, the voltage of the other capacitors of the snubbers start to decrease. As shown in this figure the voltages of the snubbers become zero about 4 μ s after the turn-on transition of the IGBTs. Therefore, the proposed scheme has proper performance when the voltages of the IGBTs are unbalanced.

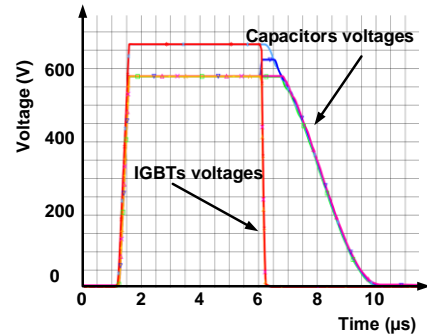

Fig. 9. Voltage of the IGBTs and the capacitors of the snubber with this assumption that one of the IGBTs is turned on 30ns after other IGBTs, and one of the IGBTs is turned off 50 ns before other IGBTs.

VI. EXPERIMENTAL RESULTS

In order to verify the proposed scheme, a prototype consists of four series IGBTs has been constructed and tested. The specifications of the test setup are presented in Table III. To implement the proposed method, a PCB including IGBTs and snubbers, a PCB for the recovery circuit, and a PCB for pulse generation have been developed and used. The photograph of the test setup is presented in Fig. 10. In this test, the leakage inductance of the transformer that is used in the recovery board is 1.65 mH. This value is enough for the resonance circuit. Therefore, there is no need for the external inductance (L_r).

The voltage of the constructed high voltage switch and the load current are shown in Fig. 11. It should be considered that the currents of the IGBTs in this scheme are different from each other and the current of the load. When the IGBTs are turned on, in addition to the load current, the snubber currents pass through the IGBTs. The voltages and the currents of the IGBTs are shown in Fig. 12. As shown in Fig. 12 (a), the first IGBT near the recovery board passes the load current and the current of all the snubbers. In addition to the load current, the second IGBT passes the current of all the snubbers except the current of the snubber of the first IGBT, so the third and fourth IGBT pass less current than the other IGBTs. The voltage of the snubber capacitors of the IGBTs are shown in Fig. 13. Comparing the voltage of the IGBTs in Fig. 12 and the voltage of snubber capacitors in Fig. 13 shows that the voltage of the snubber is equal to the voltage of the IGBTs in the turn-off transition, but in the turn-on transition because of existing decoupling diodes they are different. Also, as shown in Fig. 13, the voltage of the capacitors of the snubbers decreases to zero during the turn-on time of the IGBTs. This means that the recovery circuit completely discharges the capacitors of the snubbers.

Table III: Specification of the test setup.

L_r	1.65 mH
C_s	20 nF
Transformer turn ratio (N1:N2)	40:320
DC link capacitor	48 μ F
Load resistant	65 Ω
Total inductance	1.3 μ H
Load voltage	2500 V
IGBT part number	IKW40N120H3

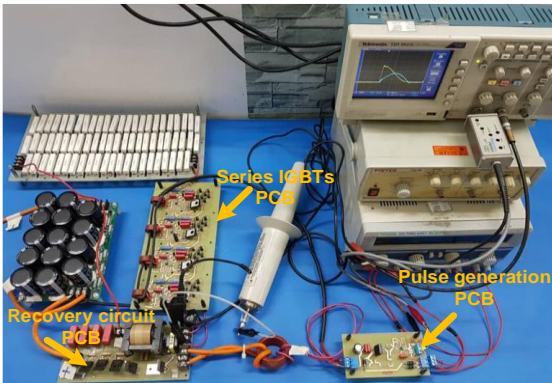

Fig. 10. Photograph of the test setup

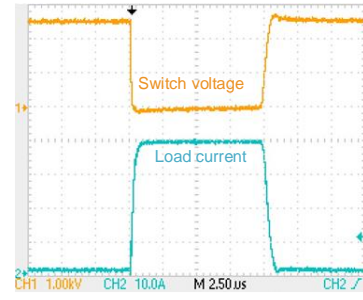

Fig. 11. Measured Load current and voltage of the series connected IGBTs during turn-on state of the IGBTs.

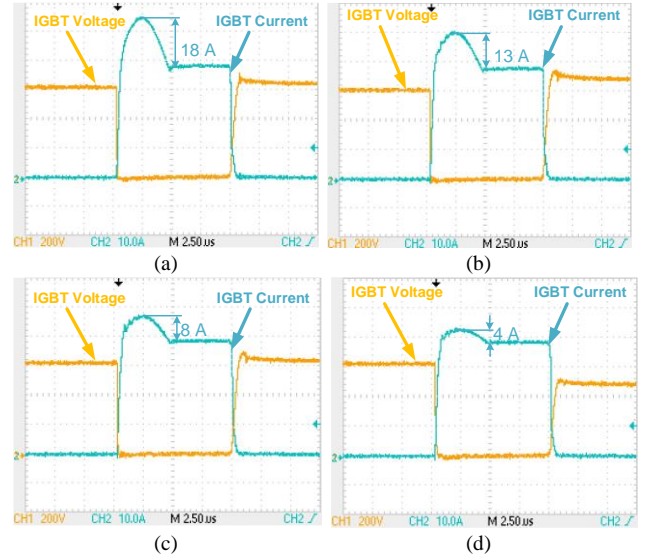

Fig. 12. Measured voltages and currents of the IGBTs a) first IGBT b) second IGBT c) third IGBT d) fourth IGBT, during a switching cycle.

The switch in the recovery circuit is turned on synchronously with the series IGBTs during the turn-on duration. Therefore, the capacitors are paralleled with the transformer, and the stored energy in the capacitors is transferred to the DC link. In Fig. 14 (a), the voltage waveform and the current waveform of the recovery circuit are illustrated. As shown in this figure, the voltage of the snubber is zero 5 μ s after the IGBTs are turned on. The injected current to the DC link by the recovery circuit and the voltage of the DC link are depicted in Fig. 14 (b).

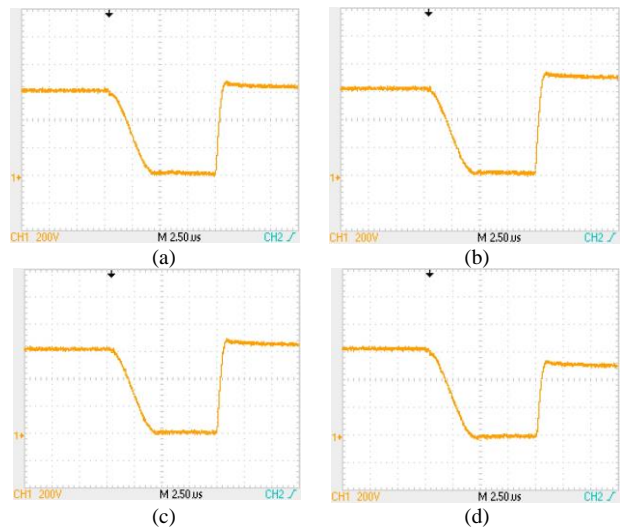

Fig. 13. Measured voltages of the snubber capacitors of the IGBTs a) first IGBT b) second IGBT c) third IGBT d) fourth IGBT, during a switching cycle.

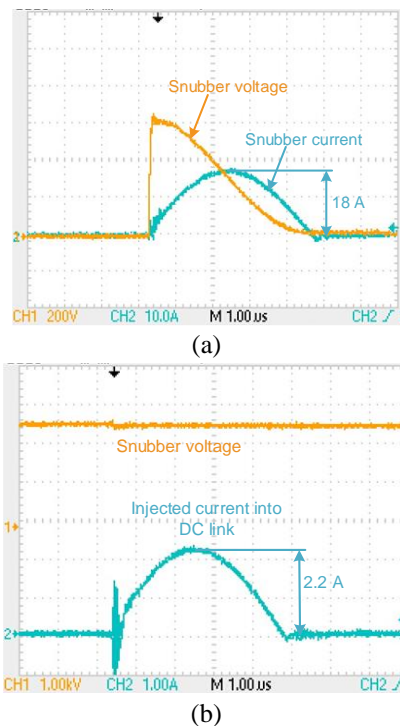

Fig. 14. a) Measured turn-on voltage and current of the snubber voltage of the DC link and b) current of the secondary winding in the transformer.

During the turn-on state of the IGBTs, the current of the snubbers passes through the primary winding of the transformer. Therefore, the current in the secondary winding, which amplitude is the amplitude of the current in the primary winding divided by the transformer turn ratio, is injected into the DC link. The initial voltage of the capacitors in the turn-off state is 625 V. Thus, the total stored energy in the capacitors is 15.62 mJ. Also, the total injected electrical charge to the DC link is 11.2 μC in each switching cycle. Therefore, the injected energy into the DC link by the recovery circuit is 14 mJ in each switching cycle. Comparing these values shows that the loosed energy in the IGBTs, diodes and the recovery circuit is 1.562 mJ, and the efficiency of the recovery scheme is 89 %.

VII. CONCLUSIONS

This paper has proposed an energy recovery scheme for traditional RCD snubbers in series-connected IGBTs. Using the proposed scheme, the stored energies of the snubber capacitors are recovered and injected back into the DC link. Using the proposed method, the power losses of the snubbers are reduced considerably. Therefore, the snubber capacitors can have a higher capacitance compared to the conventional RCD snubbers. Increasing the snubber capacitor improves the voltage balancing of the series IGBTs, and reduces their turn-off switching losses. Circuit analysis, simulation, and experimental results validate the effectiveness of the proposed scheme.

REFERENCES

- [1] R. Withanage and N. Shammass, "Series Connection of Insulated Gate Bipolar Transistors (IGBTs)," *IEEE Transactions on Power Electronics*, vol. 27, no. 4, pp. 2204–2212, Apr. 2012.
- [2] C. Xia, P. Li, X. Li, and T. Shi, "Series IGBT Chopping Strategy to Reduce DC-Link Capacitance for Brushless DC Motor Drive

- System," *IEEE Journal of Emerging and Selected Topics in Power Electronics*, vol. 5, no. 3, pp. 1192–1204, Sep. 2017.
- [3] S. Ji, T. Lu, Z. Zhao, H. Yu, and L. Yuan, "Series-Connected HV-IGBTs Using Active Voltage Balancing Control With Status Feedback Circuit," *IEEE Transactions on Power Electronics*, vol. 30, no. 8, pp. 4165–4174, Aug. 2015.
- [4] J. Chivite-Zabalza, D. R. Trainer, J. C. Nicholls, and C. C. Davidson, "Balancing Algorithm for a Self-Powered High-Voltage Switch Using Series-Connected IGBTs for HVDC Applications," *IEEE Transactions on Power Electronics*, vol. 34, no. 9, pp. 8481–8490, Sep. 2019.
- [5] P. Briff, J. Chivite-Zabalza, J. Nicholls, and K. Vershinin, "Turn-Off Delay Compensation of Series-Connected IGBTs for HVDC Applications," *IEEE Transactions on Power Electronics*, vol. 35, no. 11, pp. 11294–11298, Nov. 2020.
- [6] A. Bagheri, H. Iman-Eini, and S. Farhangi, "A Gate Driver Circuit for Series-Connected IGBTs Based on Quasi-Active Gate Control," *IEEE Journal of Emerging and Selected Topics in Power Electronics*, vol. 6, no. 2, pp. 791–799, Jun. 2018.
- [7] M. Zarghani, S. Mohsenzade, and S. Kaboli, "A High Voltage Pulsed Power Supply with Online Rise Time Adjusting Capability for Vacuum Tubes," *IEEE Journal of Emerging and Selected Topics in Power Electronics*, vol. 9, no. 3, pp. 3019–3029, June 2021.
- [8] J. Kim, B. Min, S. V. Shenderey, and G. Rim, "High Voltage Pulsed Power Supply Using IGBT Stacks," *IEEE Transactions on Dielectrics and Electrical Insulation*, vol. 14, no. 4, pp. 921–926, Aug. 2007.
- [9] P. J. Grbovic, "High-Voltage Auxiliary Power Supply Using Series-Connected MOSFETs and Floating Self-Driving Technique," *IEEE Transactions on Industrial Electronics*, vol. 56, no. 5, pp. 1446–1455, May 2009.
- [10] S. Mohsenzade, M. Zarghani, and S. Kaboli, "A High-Voltage Series-Stacked IGBT Switch With Active Energy Recovery Feature for Pulsed Power Applications," *IEEE Transactions on Industrial Electronics*, vol. 67, no. 5, pp. 3650–3661, May 2020.
- [11] T. Lu, Z. Zhao, S. Ji, H. Yu, and L. Yuan, "Active Clamping Circuit With Status Feedback for Series-Connected HV-IGBTs," *IEEE Transactions on Industry Applications*, vol. 50, no. 5, pp. 3579–3590, Sep. 2014.
- [12] V. Zornigebel, E. Spahn, G. Buderer, A. Welleman, and W. Fleischmann, "Compact High Voltage IGBT Switch for Pulsed Power Applications," *IEEE Transactions on Magnetics*, vol. 45, no. 1, pp. 531–535, Jan. 2009.
- [13] F. Zhang, X. Yang, Y. Ren, L. Feng, W. Chen, and Y. Pei, "A Hybrid Active Gate Drive for Switching Loss Reduction and Voltage Balancing of Series-Connected IGBTs," *IEEE Transactions on Power Electronics*, vol. 32, no. 10, pp. 7469–7481, Oct. 2017.
- [14] S. Ji, T. Lu, Z. Zhao, H. Yu, and L. Yuan, "Series-Connected HV-IGBTs Using Active Voltage Balancing Control With Status Feedback Circuit," *IEEE Transactions on Power Electronics*, vol. 30, no. 8, pp. 4165–4174, Aug. 2015.
- [15] F. Zhang, X. Yang, Y. Ren, C. Li, and R. Gou, "Voltage Balancing Optimization of Series-connected IGBTs in Solid-state Breaker by Using Driving Signal Adjustment Technique," in *2015 IEEE 2nd International Future Energy Electronics Conference (IFEEEC)*, pp. 1–5, Nov. 2015.
- [16] F. Zhang, X. Yang, Y. Ren, L. Feng, W. Chen, and Y. Pei, "Advanced Active Gate Drive for Switching Performance Improvement and Overvoltage Protection of High-Power IGBTs," *IEEE Transactions on Power Electronics*, vol. 33, no. 5, pp. 3802–3815, May 2018.
- [17] H. Choe, Y. Chung, C. Sung, J. Yun, and B. Kang, "Passive Snubber for Reducing Switching-Power Losses of an IGBT in a DC–DC Boost Converter," *IEEE Transactions on Power Electronics*, vol. 29, no. 12, pp. 6332–6341, Dec. 2014.
- [18] R. Parvari, M. Zarghani, and S. Kaboli, "RCD snubber design based on reliability consideration: A Case Study for Thermal Balancing in Power Electronic Converters," *Microelectronics Reliability*, vol. 88–90, pp. 1311–1315, Sep. 2018.
- [19] C. U-Yaisom, W. Khanngern, and S. Nitta, "The Study and Analysis of the Conducted EMI Suppression on Power MOSFET Using Passive Snubber Circuits," in *2002 3rd International Symposium on Electromagnetic Compatibility*, May 2002, pp. 561–564.
- [20] H. K. Patel, "Voltage transient spikes suppression in flyback converter using dissipative voltage snubbers," in *2008 3rd IEEE Conference on Industrial Electronics and Applications*, Jun. 2008, pp. 897–901.

- [21] X. Chen, L. Yu, T. Jiang, H. Tian, K. Huang, and J. Wang, "A High-Voltage Solid-State Switch Based on Series Connection of IGBTs for PEF Applications," *IEEE Transactions on Plasma Science*, vol. 45, no. 8, pp. 2328–2334, Aug. 2017.
- [22] M. Son, T. Lee, S. Kwon, and Y. Cho, "Impact of Snubber Parameters on Voltage Sharing in Series-connected Insulated Gate Bipolar Transistors," *J. Power Electron.*, vol. 20, no. 4, pp. 1002–1014, Jul. 2020.
- [23] R. T. H. Li, H. S. Chung, and A. K. T. Sung, "Passive Lossless Snubber for Boost PFC With Minimum Voltage and Current Stress," *IEEE Transactions on Power Electronics*, vol. 25, no. 3, pp. 602–613, Mar. 2010.
- [24] J. Itoh and K. Nagayoshi, "A New Bidirectional Switch With Regenerative Snubber to Realize a Simple Series Connection for Matrix Converters," *IEEE Transactions on Power Electronics*, vol. 24, no. 3, pp. 822–829, Mar. 2009.
- [25] J. Lin, S. Lee, C. Ting, and F. Syu, "Active-Clamp Forward Converter With Lossless-Snubber on Secondary-Side," *IEEE Transactions on Power Electronics*, vol. 34, no. 8, pp. 7650–7661, Aug. 2019.
- [26] G. Tibola, E. Lemmen, J. L. Duarte, and I. Barbi, "Passive Regenerative and Dissipative Snubber Cells for Isolated SEPIC Converters: Analysis, Design, and Comparison," *IEEE Transactions on Power Electronics*, vol. 32, no. 12, pp. 9210–9222, Dec. 2017.