



Aalborg Universitet

AALBORG UNIVERSITY
DENMARK

Design and implementation of prepaid power billing system in smart grid environment

Rashid, Faizan; Rasheed, Saim; Farooq, Ahsan; Ali, Majid; Ruben, Youel; Jehanzeb, Muhammad; Wahab, Abdul

Published in:
International Journal of Electrical and Computer Engineering

DOI (link to publication from Publisher):
[10.11591/ijece.v12i4.pp3365-3374](https://doi.org/10.11591/ijece.v12i4.pp3365-3374)

Creative Commons License
CC BY-SA 4.0

Publication date:
2022

Document Version
Publisher's PDF, also known as Version of record

[Link to publication from Aalborg University](#)

Citation for published version (APA):
Rashid, F., Rasheed, S., Farooq, A., Ali, M., Ruben, Y., Jehanzeb, M., & Wahab, A. (2022). Design and implementation of prepaid power billing system in smart grid environment. *International Journal of Electrical and Computer Engineering*, 12(4), 3365-3374. <https://doi.org/10.11591/ijece.v12i4.pp3365-3374>

General rights

Copyright and moral rights for the publications made accessible in the public portal are retained by the authors and/or other copyright owners and it is a condition of accessing publications that users recognise and abide by the legal requirements associated with these rights.

- Users may download and print one copy of any publication from the public portal for the purpose of private study or research.
- You may not further distribute the material or use it for any profit-making activity or commercial gain
- You may freely distribute the URL identifying the publication in the public portal -

Take down policy

If you believe that this document breaches copyright please contact us at vbn@aub.aau.dk providing details, and we will remove access to the work immediately and investigate your claim.

Design and implementation of prepaid power billing system in smart grid environment

Faizan Rashid¹, Saim Rasheed², Ahsan Farooq¹, Majid Ali¹, Youel Ruben¹, Muhammad Jehanzeb¹, Abdul Wahab¹

¹Department of Electrical Engineering, The University of Lahore, Lahore, Pakistan

²Department of Information Technology, King Abdulaziz University, Jeddah, Saudi Arabia

Article Info

Article history:

Received Apr 29, 2021

Revised Mar 18, 2022

Accepted Mar 29, 2022

Keywords:

Arduino Uno

Bluetooth

Energy meter

Global system for mobile

communication

Proteus

ABSTRACT

This paper presents the real-time monitoring of energy consumption utilizing the global system for mobile communication (GSM) via wireless protocols. The power supply company has the authority to change or alter the tariff rates. The method of payment is prepaid, so there will be options for the customer to request the number of units assigned to the particular meter against the money. The customer can monitor the number of units consumed with the help of GSM. If the units are ten percent of the total units, then the system will give a warning message so that the customer can recharge it before cutting off the supply. A GSM-based wireless module has remote access to the usage of electricity. Simulation is done on Proteus while the hardware is implemented using the microcontroller Arduino Uno.

This is an open access article under the [CC BY-SA](https://creativecommons.org/licenses/by-sa/4.0/) license.

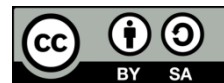

Corresponding Author:

Faizan Rashid

Department of Electrical Engineering, The University of Lahore

1-km Defence Road of Raiwind Road, Lahore, 54000, Pakistan

Email: faizan.rashid.2019@gmail.com

1. INTRODUCTION

Electrical energy plays a significant role in our daily routine life. Everything happening in the surroundings is dependent on electricity. With the latest technologies, electricity is not just bound to industries or houses as well as it is now a source for the automobile industry and many others accordingly. The world is watching the advancement in technology, so there is a need for automation and smart modules to control the demand and supply. The internet of things (IoT) is the latest term in technology. In the modern world, its applications are found in many areas related to smart and automated control of power. Some of the most common applications of IoT are referred to as: building automation, smart homes, wireless communication, and security systems.

Technology is exaggerating day by day, at the same instant, the system needs high security and automation [1]. A country that wants to advance its living standards and grow its economy must have a bulk of energy supply. The cost of electrical energy has been provoking over the years. In developing countries like Pakistan, electromechanical energy meters are in use for decades [2]. The manufacturing cost of these is low as well as these meters have several bad aspects that are not possible to neglect. In the traditional billing system, the energy meters are located at the location of the user, and the meter reader is required to go to the user location to record the energy consumption of the user then the information is communicated to the power supply utility to charge the user [3]. In some cases where it is difficult to record the meter reading, the bills are estimated, and it is one of the major concerns of the users [4]. In the traditional metering and billing systems the tempering of energy meters is quite common and also the meter reader tempered the reading of

the residential or commercial consumer for a bribe [5], [6]. The customer and the billing sector in the country have to face several errors because most of the work is being done with help of manpower and there is no automation [7]. The traditional billing system has no advantage other than mere billing that is also erroneous, power outages are a common problem, and the response time of the utility personnel is insufficient.

The advanced technologies in developed countries have changed life as well as they are running operations with automation [8]. Pakistan needs to implement the same technological developments to make human life better. There is a high increase in demand for energy with the latest housing schemes. With the increasing energy demand, there is a need for an automated energy meter or smart energy meter. Smart energy meters not only give great accuracy but also reduced tampering. It provides the best customer care by sending a warning message of low balance and power consumption updates [9].

In smart billing, the method of payment is prepaid [10]. In this method, the customer buys the number of units that he needs to use for the activities. It is his concern whether he makes use of those purchased units effectively or finishes them in one day. Once the units purchased are consumed, the customer needs to purchase the units again. The goal of this system is to design and implement a prepaid power billing system with load control to direct the amount of electricity supplied. The critical requirement for the implementation of smart energy metering is the connectivity between the user and power supply utility. Every meter needs to communicate with the database effectively [11]. Smart energy meters measure the voltage, current, and energy consumption and provide real-time information to the user [12]. The information is provided to the user via global system for mobile communication (GSM) technology, and the user can monitor the information on the mobile [13]. Some of the advantages of prepaid power billing are as follows: easy to read on your meter screen, much more convenient and straightforward for consumer's busy life, decline the manpower, option to control the loads, and paper saving as no need to print the bills.

GSM is used in the system. GSM stands for Global system for mobile communication. It is commonly used for communication all around the world. Generally, it operates at 850 MHz, 900 MHz, 1800 MHz, and 1900 MHz frequency bands and its ability to carry data rates is about 64 kbps to 120 Mbps [14], [15]. In this system, GSM SIM900A is used for sending and receiving data. It is acting as a communicator between the user and smart meter doing power billing [16].

The microcontroller that is used in the system is Arduino Uno. Arduino Uno is the most common type of microcontroller. Arduino usually contains eleven digital pins where some digital pins are pre-owned as the pulse width modulation (PWM) pins, six analog pins, three ground pins, two VCC pins, and one TX and RX pin [17]. Generally, Arduino is used for programming electrical systems. Bluetooth HC05 is adopted in the system for changing tariffs, and the power supply company has the authority to alter tariff rates. Bluetooth is a wireless device used for communication. Bluetooth is a short-range (around 10 meters) device and receives and transmits data at 2.4 GHz frequency bands [18], [19].

In an experimental study based on more than 300 consumers, it was found that, smart meters are good for consumers as well as they are not ready for the implementation of these meters [20]. For instance, clients' reaction against smart meter deployment may be incited by issues such as a privacy violation, have an effect on bodily well-being due to radiation from the radio frequency of these meters, and heavy bills [21]. Negative reactions from purchasers may additionally hinder the implementation of smart meters, as visible in the USA and numerous European nations [22]–[24].

To overcome the problem of theft, overbilling, meter alleviating, a prepaid energy is made in Pakistan [25]. A case study was done in Pakistan for implementation of GSM based smart energy meters to be implemented for safe and secure reading and to avoid a meter reader from doing any changes in the reading [26]. Every year many of the dollars lost in fraud and meter reading alterations and illegal activities of the consumers [27]. From these aforementioned issues, we have decided to have a system in Pakistan, which would be efficient and be able to control the load using GSM.

This paper is comprised of the following sections: In the first section, general information is discussed while section 2 represents the proposed system. In section 3 focuses on calculation. Moreover, sections four consists of simulation and hardware results. In the last section, the conclusion is discussed.

2. PROPOSED METHOD

Figure 1 exhibits the block diagram of the system. In the block diagram, power is supplied to the step-down transformer and current transformer (CT), and the resultant pulses (voltage and current) are given to the microcontroller with the help of a supporting circuit. 20×4 Liquid crystal display (LCD) is used in the system for displaying output. All the steps that are related to load control are performed by the customer through GSM. First of all, the customer has to purchase units for turning on the load. After that customer with his registered number will send a short message service (SMS) to GSM for turning on the load. If units are less than 10% of the total units, then the system will send an SMS to the customer, "Your Balance is

low". If the units become zero, then the system will cut off the supply and send the SMS to the customer, "You have no Balance". The main feature in this system is the customer can get the update of energy consumption by just sending an SMS to the GSM. He can control his load remotely. A power supply company like Lahore electric supply company (LESCO) in Pakistan has the authority to change tariff rates. The power supply company is connected to the billing meter through Bluetooth. It can change the tariff at any time for the consumer. The consumer has to purchase the units according to new tariff rates next time.

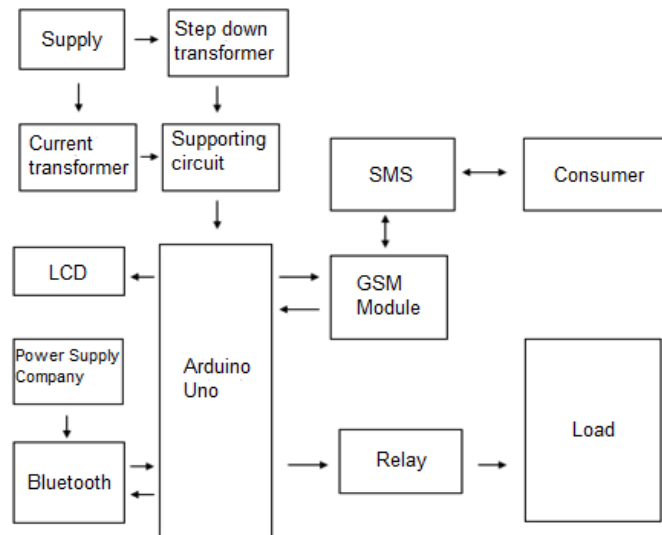

Figure 1. Block diagram

3. RESEARCH METHOD

Transformer designing has a partial factor in software implementation. 220 V AC to 5 V AC step-down transformer is designed by (1).

$$L_{sec}/L_{pri} = (V_{sec}/V_{pri})^2 \quad (1)$$

After calculating L_{sec} value of the step-down transformer, it is added to the transformer properties shown in the Figure 2. So, 220 V AC to 5 V AC transformer is successfully achieved. The microcontroller can be burn by providing alternating current (AC) signal. The signal that is given to the microcontroller must be in between 0 V to 5 V. By using a combination of resistors and capacitor which is giving direct current (DC) offset to the signal that is moved between 0 V to 5 V and it is given to the microcontroller shown in the Figure 3. The output of the waveform of the signal is shown in the Figure 4.

As a result, there is no negative cycle in this analog signal and it can be given to the microcontroller. By converting the analog signal into a digital signal, voltages are measured. For the current measurement, ACS712 current sensor is used in Proteus. The current in the wire is detected by the current sensor and generates an output analog signal which is proportional to the current. This analog signal is given to the microcontroller that converts the analog signal to the digital signal and the current is measured. Power can be calculated by the (2).

$$Power = Voltage \times Current \times \cos \theta \quad (2)$$

The unit of power is the watt. If a one-kilowatt load is consumed in one hour, then one electrical unit (kWh) is consumed. The unit is measured by the following formula given in (3).

$$Unit = \frac{watt}{1000} \times 3600 \quad (3)$$

For calculating power factor, the time difference or phase difference is measured between two signals (i.e., current signal and voltage signal) and converting time into the degree, that's how power factor is measured by the (4):

$$\cos \theta = F \times dt \times 360 \tag{4}$$

where F is the frequency, dt is the time difference and 360 is a constant used for converting time into a degree.

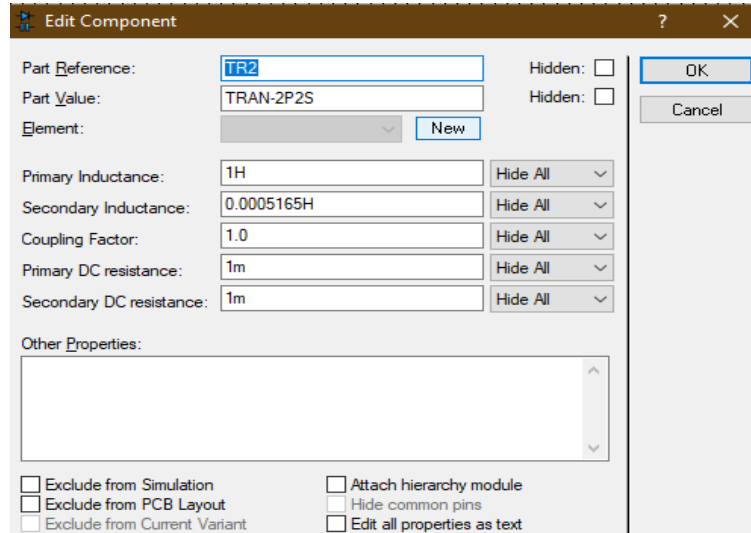

Figure 2. Transformer designing

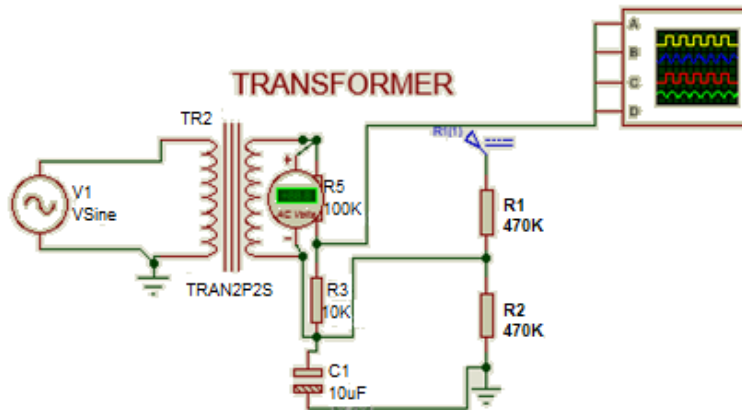

Figure 3. Potential transformer signal

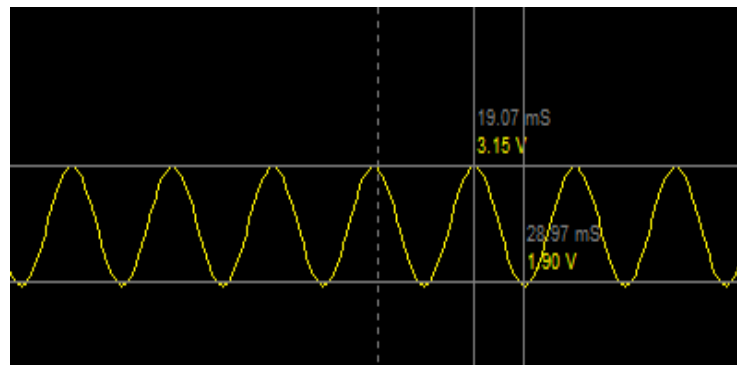

Figure 4. Oscilloscope waveform in Proteus

4. RESULTS AND DISCUSSION

The simulations and hardware results have been achieved which are discussed hereunder. In section 4.1, Proteus software simulation have been discussed. Whereas in section 4.2, hardware discussion is made.

4.1. Software results

On Proteus software, a detailed analysis has been done then designed a simulation of the proposed system. There are four figures where the main results are shown. Figure 5 shows the software simulation whereas Figure 6 shows 20 × 4 LCD. It is showing the current statics of parameters running in the project at the moment. Figure 7 shows the virtual window in which the functions are performed by the customer. If the customer sends the command “ZA” to the GSM then the relay will be opened and loads will be disconnected from the supply. GSM (SIM900A) is used in the system, which is acting as a wireless communication protocol between the system and the customer. Now, if the customer presses “ZB” then the loads will be in ON state because the relay has been closed now. The current statics are sent to the customer by pressing “ZU” which is shown in Figure 7. The units are added to the system by pressing “Z1” for one unit. Similarly, by pressing “Z2” two units are added. Likewise, the customer can add up to “Z9” in the project which means 45 units in the system. The customer has to send an SMS to the power supply company from the registered number that is displayed on LCD in Figure 6. Now, if the consumer wants to change his registered mobile number, he will simply press “Z0”, and write his new number to change his phone number on which he will receive the future information associated with the meter.

Also, the power supply company can alter the tariff rates by sending the command “Z13” via Bluetooth. It will change the tariff to the rate of Rs. 13 per unit. Figure 8 shows the virtual window of Bluetooth commands. All the commands performed by the user and its working is shown in Table 1.

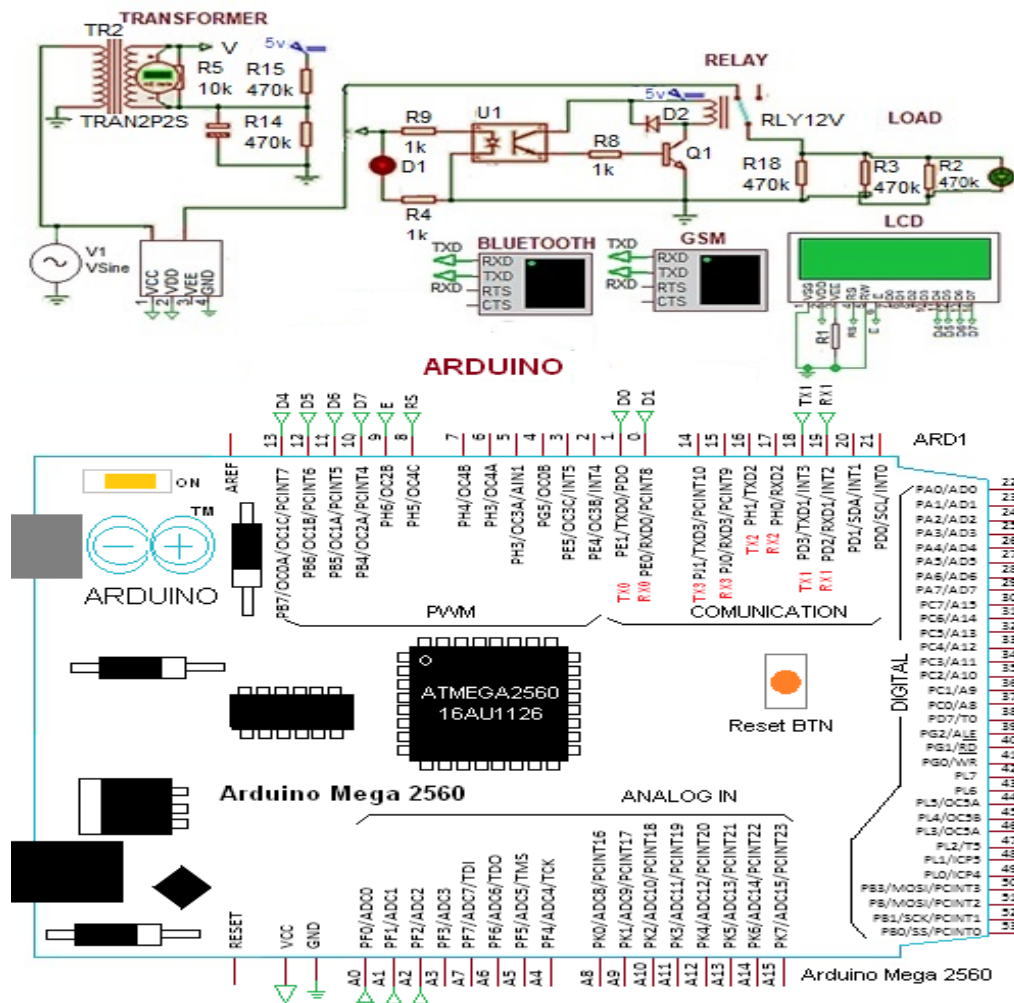

Figure 5. System schematics

4.2. Hardware results

To drive the system, the microcontroller ARDUINO UNO is used to perform all the functions related to the project. Arduino develops free software known as an integrated development environment (IDE) used to write a program. Arduino IDE is the most commonly used software just because of user-friendly interference. Programs are written in IDE software in C or C++ language [14]. After writing the program in IDE, the HEX file is generated. Then this HEX file is uploaded to the microcontroller.

In this system, we are getting the main supply from WAPDA which is 220 V AC, and connected an adopter that converts 220 V AC to 5 V DC as all the components such as Bluetooth module HC-05, Arduino, GSM, embedded in the system, are operating on 5 V DC. Bluetooth module HC-05 is used only to communicate with the consumer from the supplier side. Bluetooth is chosen just because its response time is fast than GSM. The power supply company will simply change tariffs while sitting in the room. Bluetooth is interfaced with a microcontroller and has four pins that are TXD, RXD, VCC, and ground. TXD pin is always attached to the RXD pin of the microcontroller and vice versa. VCC is provided with the 5 V source moreover the ground is attached to the circuit ground.

PT and CT are used to measure the potential and current. The transformer is stepping down 220 V AC to 5 V AC, by using a combination of resistors and capacitor we moved the signal between 0 V to 5 V DC. This analog signal as shown in Figures 9 and 10 is given to the microcontroller. The microcontroller converts the analog signal into a digital value. So, voltages are measured from this analog signal. Similarly, in the case of the current transformer (CT), the current is measured by the same strategy. Power is measured by multiplying voltage and current and units are measured as mentioned earlier.

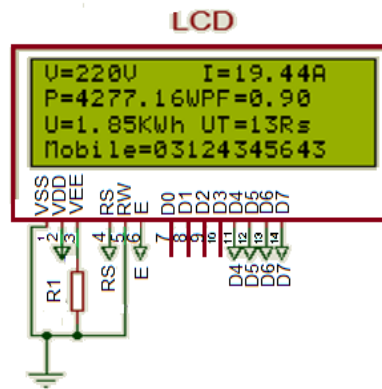

Figure 6. LCD output

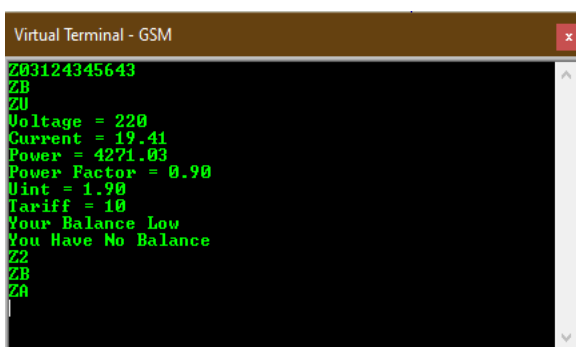

Figure 7. Virtual terminal of GSM

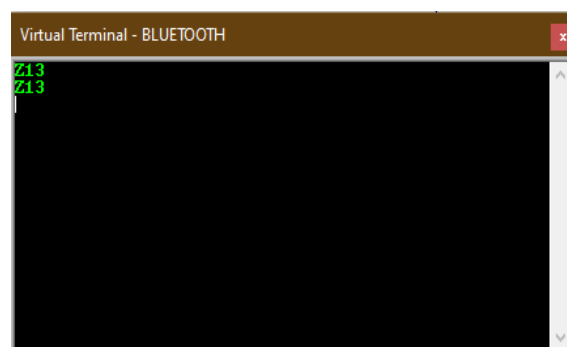

Figure 8. Virtual terminal of Bluetooth

Table 1. Commands of the user

Commands	Working
ZB	Load ON
ZA	Load OFF
ZU	Real time update
Z1-Z9	Units adding
Z0xxxxxx	Number changing

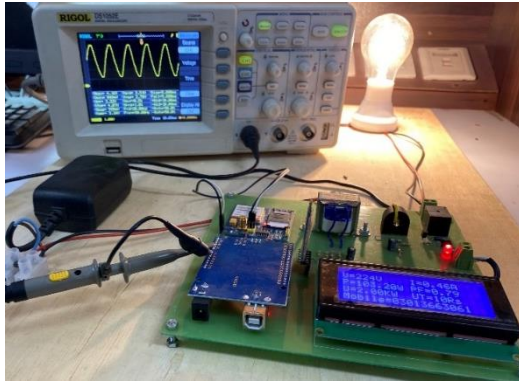

Figure 9. Oscilloscope result across PT

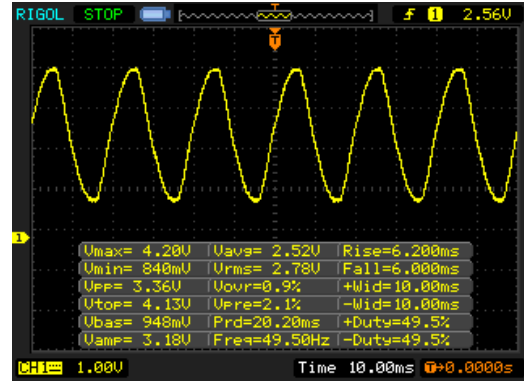

Figure 10. Waveform

Relay is also attached to the system to switch ON or OFF the loads. For operating the relay, relay driver circuit is used. In relay driver circuit, optocoupler PC817, BJT transistor and diode IN4007 is used. Optocoupler is also called an opto-isolator. Optocoupler is used for isolating two circuits. The circuit has an infrared emitting diode (IRED) while the other one has a photo sensor that senses the light and gives a differential output. Optocoupler is attached to the pin A0 of the Arduino.

Moreover, Bluetooth application is used on the mobile phone name Bluetooth terminal which is connected to the Bluetooth module by pairing both sides. By typing the command on the application from the phone and it transfers the signal wirelessly to the module attached to the project. Suppose the user types Z12, it will change the rate Rs. 10 to Rs. 12 per unit cost in the whole system. Afterward, the number of units added to the system will cost the consumer with new tariff rate. In real-time, the supplier can change the rate of tariff according to his own will.

GSM module is used to communicate wirelessly with phone and system. This module is attached to only one mobile number of the user at a time. If a user loses his phone, he can change his number by sending message to the GSM. For communication through GSM, AT command is used. For sending a message to GSM, "AT+CMGS" is used. For sending a message from internal memory, "AT+CMSS" is used, and reading a message, "AT+CMGR" is used [15]. It is being used to update the consumer about the current information and status of voltage, current, power factor, power, and remaining units.

If the consumer sends a SMS "ZA" to the energy meter (GSM), the loads will get in OFF state, and by sending a SMS "ZB", the relay will be closed and loads will be attached to the supply and become in ON state. Now, if the consumer wants to check its status and the remaining balance of the meter, he will send a SMS "ZU" to the energy meter then update will send to the customer. The customer can change his phone number through GSM by sending a SMS "Z0 (new number)" to the energy meter. Units can be added by entering the command of "Z1-Z9". The consumer has two SIMs in use: one for the GSM module and another one for our mobile phone. The consumer will send the specific command reserved for only tasks involving GSM communication. The communication between the customer and supplier is shown in Figures 11 and 12. The final hardware prototype is shown is Figure 13 where Arduino, Bluetooth, CT, PT, relay, and LCD is combined to perform power billing and load controlling through GSM.



Figure 11. Controlling load through GSM



Figure 12. LCD output

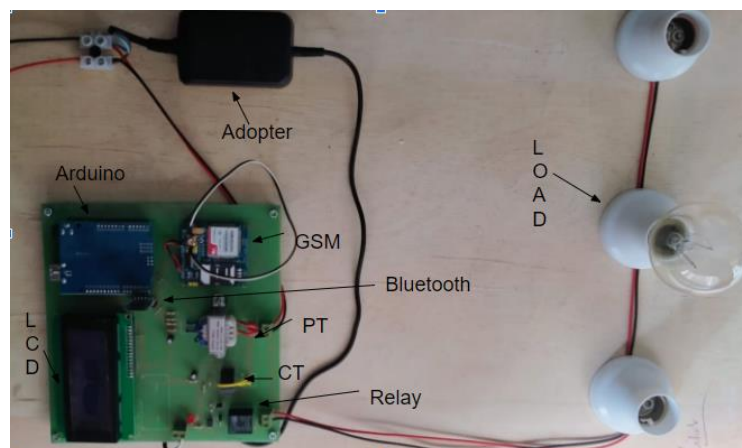

Figure 13. Combined hardware prototype

5. CONCLUSION

To recapitulate, a prepaid energy meter is like mechanization of the first recharge, then service prototype and more user-friendly as it has many benefits including the reduction of manpower. The meter that is developed is capable of prepaid charging of energy, load control sector, and remain up to date about the current status. It is proficient to use for small commercial as well as industry and residential needs. It is also having a top-notch ability of two-way communication between the smart meter and consumer through the GSM module for sending and receiving the immediate inducements, whereas the Bluetooth module useful for a supplier in which it can change the tariffs accordingly.



REFERENCES

- [1] B. Ali and A. Awad, "Cyber and physical security vulnerability assessment for IoT-based smart homes," *Sensors*, vol. 18, no. 3, Mar. 2018, doi: 10.3390/s18030817.
- [2] S. H. Mir, S. Ashruf, Sameena, Y. Bhat, and N. Beigh, "Review on smart electric metering system based on GSM/IOT," *Asian Journal of Electrical Sciences*, vol. 5, no. 1, pp. 1–6, 2019.
- [3] M. S. Hossain, M. Rahman, M. T. Sarker, M. E. Haque, and A. Jahid, "A smart IoT based system for monitoring and controlling the sub-station equipment," *Internet of Things*, vol. 7, Sep. 2019, doi: 10.1016/j.iot.2019.100085.
- [4] N. Shabbir, M. Usman, M. Jawad, M. H. Zafar, M. N. Iqbal, and L. Kütt, "Economic analysis and impact on national grid by domestic photovoltaic system installations in Pakistan," *Renewable Energy*, vol. 153, pp. 509–521, Jun. 2020, doi: 10.1016/j.renene.2020.01.114.
- [5] A. O. Otuoze *et al.*, "Electricity theft detection framework based on universal prediction algorithm," *Indonesian Journal of Electrical Engineering and Computer Science (IJECS)*, vol. 15, no. 2, pp. 758–768, Aug. 2019, doi: 10.11591/ijeecs.v15.i2.pp758-768.
- [6] W. Li, T. Logenthiran, V.-T. Phan, and W. L. Woo, "A novel smart energy theft system (SETS) for IoT-based smart home," *IEEE Internet of Things Journal*, vol. 6, no. 3, pp. 5531–5539, Jun. 2019, doi: 10.1109/JIOT.2019.2903281.
- [7] T. E. Somefun, C. O. A. Awosope, and A. Chiagoro, "Smart prepaid energy metering system to detect energy theft with facility for real time monitoring," *International Journal of Electrical and Computer Engineering (IJECE)*, vol. 9, no. 5, pp. 4184–4191, Oct. 2019, doi: 10.11591/ijece.v9i5.pp4184-4191.
- [8] P. P. Singh, P. K. Khosla, and M. Mittal, "Energy conservation in IoT-based smart home and its automation," in *Energy Conserv. IoT Devices*, 2019, pp. 155–177.
- [9] A. Kurde and V. Kulkarni, "IoT based smart power metering," *International Journal of Scientific and Research Publications*, vol. 6, no. 9, pp. 411–415, 2016.
- [10] P. Loganthurai, M. Shalini, A. Vanmathi, M. Veeralakshmi, and V. Vivitha, "Smart energy meter billing using GSM with warning system," in *2017 IEEE International Conference on Intelligent Techniques in Control, Optimization and Signal Processing (INCOS)*, Mar. 2017, pp. 1–4, doi: 10.1109/ITCOSP.2017.8303087.
- [11] D. B. Avancini, J. J. P. C. Rodrigues, R. A. L. Rabêlo, A. K. Das, S. Kozlov, and P. Solic, "A new IoT-based smart energy meter for smart grids," *International Journal of Energy Research*, vol. 45, no. 1, pp. 189–202, Jan. 2021, doi: 10.1002/er.5177.
- [12] B. K. Barman, S. N. Yadav, S. Kumar, and S. Gope, "IoT based smart energy meter for efficient energy utilization in smart grid," in *2018 2nd International Conference on Power, Energy and Environment: Towards Smart Technology (ICEPE)*, Jun. 2018, pp. 1–5, doi: 10.1109/EPETSG.2018.8658501.
- [13] K. C. Okafor, G. C. Ononiwu, U. Precious, and A. C. Godis, "Development of Arduino based IoT metering system for on-demand energy monitoring," *International Journal of Mechatronics, Electrical and Computer Technology (IJMEC)*, vol. 7, no. 23, pp. 3208–3224, 2017.
- [14] R. Bhavani and S. Alagammal, "Design and implementation of gsm based smart energy meter (sem) for home applications," *International Journal of Latest Trends in Engineering and Technology*, vol. 8, no. 1, pp. 431–439, 2016, doi: 10.21172/1.81.055.
- [15] P. Pawar and P. Vittal K, "Design and development of advanced smart energy management system integrated with IoT framework in smart grid environment," *Journal of Energy Storage*, vol. 25, Oct. 2019, doi: 10.1016/j.est.2019.100846.
- [16] F. Rashid, R. Ahmad, H. M. Talha, and A. Khalid, "Dynamic load sharing at domestic level using the internet of things,"



- International Journal of Integrated Engineering*, vol. 12, no. 4, pp. 57–65, 2020.
- [17] M. Verma, “Working, operation and types of arduino microcontroller,” *International Journal of Engineering Sciences and Research Technology*, vol. 6, pp. 155–158, 2017.
- [18] L. Labib, M. Billah, G. M. S. M. Rana, M. N. Sadat, M. G. Kibria, and M. R. Islam, “Design and implementation of low-cost universal smart energy meter with demand side load management,” *IET Generation, Transmission & Distribution*, vol. 11, no. 16, pp. 3938–3945, Nov. 2017, doi: 10.1049/iet-gtd.2016.1852.
- [19] G. Lobaccaro, S. Carlucci, and E. Löfström, “A review of systems and technologies for smart homes and smart grids,” *Energies*, vol. 9, no. 5, May 2016, doi: 10.3390/en9050348.
- [20] G. A. Alkaws, N. Ali, and Y. Baashar, “An empirical study of the acceptance of IoT-based smart meter in Malaysia: the effect of electricity-saving knowledge and environmental awareness,” *IEEE Access*, vol. 8, pp. 42794–42804, 2020, doi: 10.1109/ACCESS.2020.2977060.
- [21] T. Krishnamurti *et al.*, “Preparing for smart grid technologies: A behavioral decision research approach to understanding consumer expectations about smart meters,” *Energy Policy*, vol. 41, pp. 790–797, Feb. 2012, doi: 10.1016/j.enpol.2011.11.047.
- [22] C. Chen, X. Xu, and L. Arpan, “Between the technology acceptance model and sustainable energy technology acceptance model: Investigating smart meter acceptance in the United States,” *Energy Research and Social Science*, vol. 25, pp. 93–104, Mar. 2017, doi: 10.1016/j.erss.2016.12.011.
- [23] D. Castro, J. New, and A. McQuinn, “How is the federal government using the internet of things,” Center For Data Innovation, pp. 1–30, 2015.
- [24] M. Hoover, “Study: IoT adoption still slow for government agencies,” Washington Technology, 2016.
- [25] M. Saad, M. F. Tariq, A. Nawaz, and M. Y. Jamal, “Theft detection based GSM prepaid electricity system,” in *2017 3rd IEEE International Conference on Control Science and Systems Engineering (ICCSSE)*, Aug. 2017, pp. 435–438, doi: 10.1109/CCSSE.2017.8087973.
- [26] G. I. Rashed, H. Haider, and M. B. Shafiq, “Improving the reliability of energy supply utilizing smart energy meter system based on GSM: case study in Pakistan,” in *2020 5th Asia Conference on Power and Electrical Engineering (ACPEE)*, Jun. 2020, pp. 1080–1084, doi: 10.1109/ACPEE48638.2020.9136524.
- [27] M. S. Saeed, M. W. Mustafa, U. U. Sheikh, T. A. Jumani, and N. H. Mirjat, “Ensemble bagged tree based classification for reducing non-technical losses in multian electric power company of Pakistan,” *Electronics (Switzerland)*, vol. 8, no. 8, Aug. 2019, doi: 10.3390/electronics8080860.

BIOGRAPHIES OF AUTHORS





Faizan Rashid    was born in Lahore, Pakistan, He received his Bachelor and Master’s Degree in Electrical Engineering from The University of Lahore, Pakistan in 2011 and 2017 respectively. He is currently working as a Lecturer in the same university in the Electrical Engineering department. He supervised many projects at bachelor level. His research interest includes Multilevel Inverters, Distribution systems, Renewable energy resources, Circuit designing, and Machine design. He has also worked on MIMO systems and internet of things. Currently, he is doing work on integration of renewable resources such as Wind and Solar. His interests also include power electronics and its applications in smart grids, AC and DC microgrids, and integration of distribution generation with smart grids. He can be contacted at email: faizan.rashid.2019@gmail.com.





Saim Rasheed    received a B.Sc. with majors in Mathematics and Physics from Forman Christian College (FCC Lahore, Pakistan) in 1997. In 2000, he did M.Sc. in Applied Mathematics from University of the Punjab (Lahore, Pakistan). In 2003, he completed M.Sc. in Computer Science from University of the Punjab (Lahore, Pakistan) and in 2004, he joined COMSATS Institute of Information Technology Lahore for MS in Computer Science. He then completed his PhD in Computer Science in 2011 from University of Milan (Milan, Italy). Currently he is working as an Assistant Prof in King Abdul Aziz University at Department of Information Technology. His research interests include brain-computer interfaces, EEG signal processing, digital image processing, computer graphics, computer vision and human-computer interaction and interaction design. He can be contacted at email: srahmed@kau.edu.sa.





Ahsan Farooq    was born in Sheikhpura in 1997. He did intermediate from Punjab College of Sciences, Lahore, and has graduated as an Electrical Engineer from the University of Lahore. He is interested in the distribution system as well as solar energy. His research interests include the application of power electronics in wind systems, FACTS devices, and HVDC systems. He is currently working as a technical sales engineer in Pantera Energy. He can be contacted at email: engr.ahsanfarooq@gmail.com.





Majid Ali    received his BS (2013) and MS (2015) in Electrical Engineering from University of Management & Technology (UMT) Lahore Pakistan on fully funded Scholarship. He was Gold and Bronze Medalist in the field of Electrical Technology from Punjab Board of Technical Education (PBTE) Lahore. Currently he is working as a Lecturer in Electrical Engineering Department of The University of Lahore His research interest includes Power Distribution Systems, Power system Analysis. He can be contacted at email: engr.majidali.baig@gmail.com.





Youel Ruben    was born in Gujranwala, Pakistan in 1998. He had attained a degree in Electrical Engineering from the University of Lahore Pakistan in 2020. His research interest includes generation systems, Transmission lines, and distribution systems. He is an active member of IEEE Student Branch at the University of Lahore and Pakistan Engineering Council. He has also Participated in Faculty Development Workshops and Seminars on Communication Science and System. He can be contacted at email: engryouelruben@gmail.com.



Muhammad Jehanzeb    was born in Gujranwala, Pakistan in 1998. He had attained a degree in Electrical Engineering from the University of Lahore in 2020. His research interest includes circuit designing, power system protection. Wide ranging expertise in computing software e.g., Microsoft Office package. Proven oral and written communication skills, possesses the ability to work effectively both as member of a team and independently, committed to achieving goals, proactive, responsible and have a good ability to learn new things. He can be contacted at email: muhammadjehanzeb18@gmail.com.



Abdul Wahab    was born in Gujranwala, Pakistan. He was graduated from the University of Lahore, Pakistan in 2020. His research interests include Hydro-Electric system. He is pursuing a master's degree in renewable energy resources. He can be contacted at email: abdulwahabcheema1@gmail.com.