



AALBORG UNIVERSITY
DENMARK

Aalborg Universitet

Reliability Modeling and Assessment of De-rated Redundant Power Converters

Peyghami, Saeed; Abarzadeh, Mostafa; Blaabjerg, Frede

Published in:

Proceedings of the 2022 International Power Electronics Conference (IPEC-Himeji 2022- ECCE Asia)

DOI (link to publication from Publisher):

[10.23919/IPEC-Himeji2022-ECCE53331.2022.9806972](https://doi.org/10.23919/IPEC-Himeji2022-ECCE53331.2022.9806972)

Publication date:

2022

Document Version

Accepted author manuscript, peer reviewed version

[Link to publication from Aalborg University](#)

Citation for published version (APA):

Peyghami, S., Abarzadeh, M., & Blaabjerg, F. (2022). Reliability Modeling and Assessment of De-rated Redundant Power Converters. In *Proceedings of the 2022 International Power Electronics Conference (IPEC-Himeji 2022- ECCE Asia)* (pp. 2544-2551). Article 9806972 IEEE. <https://doi.org/10.23919/IPEC-Himeji2022-ECCE53331.2022.9806972>

General rights

Copyright and moral rights for the publications made accessible in the public portal are retained by the authors and/or other copyright owners and it is a condition of accessing publications that users recognise and abide by the legal requirements associated with these rights.

- Users may download and print one copy of any publication from the public portal for the purpose of private study or research.
- You may not further distribute the material or use it for any profit-making activity or commercial gain
- You may freely distribute the URL identifying the publication in the public portal -

Take down policy

If you believe that this document breaches copyright please contact us at vbn@aub.aau.dk providing details, and we will remove access to the work immediately and investigate your claim.

Reliability Modeling and Assessment of De-rated Redundant Power Converters

Saeed Peyghami^{1*}, Mostafa Abarzadeh², Frede Blaabjerg³
^{1,3} Department of Energy, Aalborg University, Aalborg, Denmark
² SmartD Technologies Inc., Montreal, Canada
*E-mail: sap@energy.aau.dk

Abstract—This paper proposes a reliability modeling approach and a reliability measure for redundant power converters with the possibility of de-rated operation. The proposed model takes into account the operating condition and its impact on the converter failure rate. Furthermore, the proposed reliability index is based on an availability measure, hence incorporating the impact of maintenance on the converter performance. However, the conventional reliability modeling approaches rely on either the probability of failure or availability based on the average failure rate. As a result, the proposed method introduces more accurate and realistic reliability performance. The proposed model is applicable for reliability assessment in power electronics systems for expert decision-making in asset management. The proposed approach is examined using a multi-level converter and a proper control system is proposed to operate the converter under de-rated operating conditions. The numerical analysis shows the proficiency of the proposed reliability modeling approach.

Keywords— *Availability, Reliability, Redundant converter, De-rated operation.*

I. INTRODUCTION

Power electronics will be the backbone of modern energy systems [1]. They are employed for power conversion in various applications, recently with more attention on high-power cases such as medium voltage transmission systems, electric vehicle charging stations, renewable generations, etc. In order to guarantee the desired performance of these systems, the converters must be designed and operated with a specified reliability level [2]. Thus, reliability modeling, assessment, and enhancement become of paramount importance to ensure demanded reliability of power converters.

Various methods have been presented for reliability analysis in power electronic systems. These methods can be categorized into device-, converter- and system-level approaches [3]. Furthermore, the state-of-the-art analyses methods can be classified as modeling approaches, assessment methods, and enhancement techniques that can be applied at device-, converter-, or system-level.

Reliability modeling approaches in power electronics are recently dedicated to wear-out failure prediction [4]–[6]. Furthermore, the system-level reliability modeling with high penetration of power converters is presented in order to evaluate the performance of power electronic-based power systems [7]. In these methods, the mission profile is considered and the converter end of life is

predicted using physics of failure analysis. In [8], in order to model the impact of converters on power system reliability, the converter availability modeling considering the physics of failures is introduced.

In order to guarantee/enhance the converter reliability, the concept of design for reliability is introduced based on the physics of failure analysis [9]–[12]. According to this concept, different factors such as components lifetime, thermal design, cooling system, switching frequency, control algorithms are taken into account to ensure the desired reliability of the converter. The design for reliability concept is further extended to power electronic-based power systems for planning and maintenance scheduling purposes by a model-based V-shape reliability assessment technique [8].

Another factor affecting the converter reliability is the converter structure that needs to be considered during the design process. Appropriate design and selection of converter structure can help the enhancement of overall reliability [13]. Among various converter structures, redundant schemes are gaining more attention due to inherent fault-tolerant capability [14]–[18]. Especially moving toward high-power applications, Power Electronics Building Blocks (PEBB) are introduced to make the converters more reliable and fault-tolerant. Converters based on PEBB have the opportunity to operate in either redundant mode or de-rated mode to maintain the system availability. Depending on the converter control and hardware design, it can reserve one or more PEBB for redundancy and operate in the full rated power. Moreover, it can be operated in the de-rated mode if any of PEBB in the full-rated converter fails. Both approaches make them to be a promising solution for resilient power electronic-based power systems.

Recent reliability modeling and assessment approaches in modular multi-level converters rely on wear-out failure rate prediction [19]–[21]. In this approach, the probability of failure is predicted and the converter is designed based on the overall reliability performance. This approach provides better insight into the thermal stress on the devices and is hence suitable for the device level reliability enhancement approaches such as active and passive thermal management, device reinforcement, etc. In this method, the entire reliability is predicted based on the probability of failure of components. However, the maintainability of converters is not considered, while it can remarkably impact the converter performance, and hence design optimization. Therefore, it is more suitable for mission-oriented systems like space applications where the first time to failure matters.

In grid applications where the converters are

This work was supported by VILLUM FONDEN under the VILLUM Investigators Grant called REPEPS at the Department of Energy, Aalborg University, Denmark.

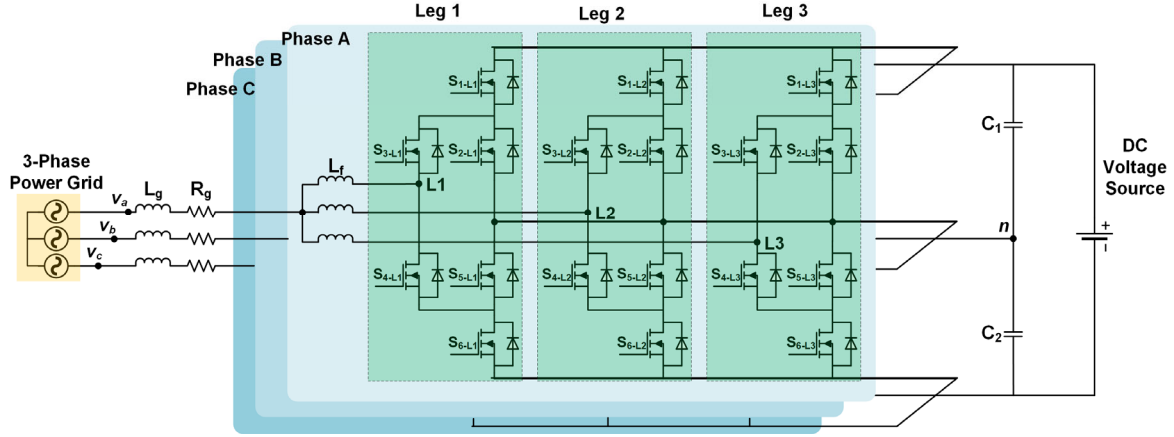

Fig. 1. Structure of a high-power modular redundant converter.

maintainable, the aforementioned method is not providing practical insight/guidelines to the optimal design and operation of converters. Especially, modular multi-level converters are inherently redundant, and hence failure of several modules may not affect the overall performance of the converters. This is of high importance for high/medium voltage transmission systems, where the converters can be operated with a de-rated power until failed parts are repaired. Therefore, besides wear-out failure probability prediction, maintainability needs to be taken into account. The maintenance strategy and its impact on the converter availability can remarkably affect the design of the converter including its component and number of redundant modules as well as the control and operation strategies under fault conditions. This is due to the fact that the converter failure rate depends on the operating conditions [22]. Therefore, a reliability measure and corresponding modeling approach are required to be developed to take into account the converter failure rate under different operating conditions, i.e., mission profile, its maintainability and maintenance strategies, device-level reliability characteristics as well as control and operation strategies.

This paper proposes a general reliability modeling approach for the de-rated operation of redundant power electronic converters. It takes into account the operating conditions as well as the maintainability. The proposed method is exemplified for a modular multi-level converter. The converter structure and operation strategy are discussed in Section II. The proposed reliability model is presented in Section III. Section IV illustrates the numerical analysis. Finally, the paper is summarized in Section V.

II. OPERATION AND CONTROL OF REDUNDANT CONVERTERS

Redundant power electronic converters provide fault-tolerant operation which is comprised of detection of a fault, isolation of a failed component, and reconfiguration of power electronic converter to remain functional after failure. Hence, the hardware and control system of redundant power electronic converter are specifically designed to be capable of desired fault-tolerant operation. In order to provide hardware redundancy for redundant power electronic converters, various solutions have been introduced which can be classified as 1) device-level, 2)

leg-level, 3) module-level, and 4) converter-level hardware redundancy. Leg-level hardware redundancy is more popular technique among above-mentioned methods because of providing a compromise between converter cost and performance of redundant power electronic converter. In this method which is based on employing an extra redundant parallel leg, the redundant fourth leg is parallel connected with three-leg three-phase converter to form a fault-tolerant redundant converter [16], [17].

Multilevel converters specifically neutral-point-clamped (NPC), active-NPC (ANPC), and modular multilevel converters are among most promising solutions for fault-tolerant redundant power electronic converters because of providing more redundant switching states during faulty conditions [14], [15]. In [18], a parallel-connected modular ANPC (PM-ANPC) converter comprising three identical ANPC legs in each phase has been introduced to provide scalability, higher power rating, and improved harmonic spectrum. A generalized scalable hybrid PM-ANPC converter has also been introduced in [23]. The PM-ANPC converter is presented in Fig. 1. As can be seen in Fig. 1, the existence of three identical ANPC legs per phase of the PM-ANPC converter provides the inherent leg-level fault-tolerant capability for the PM-ANPC converter. Hence, in contrast with conventional ANPC converter in which the fourth leg should be added to the three-leg ANPC converter to form a fault-tolerant converter, in the PM-ANPC converter, the converter only needs to be de-rated during failure of one or more ANPC legs of the converter.

Notably, the proposed reliability model is applicable to any kind of redundant power converter. This paper examines the proposed method for PM-ANPC as one of the popular redundant converters with the better possibility of de-rated operation. Therefore, without losing the generality, the proposed approach is explained using this converter as an example.

A. The parallel modular ANPC (PM-ANPC) converter configuration

As presented in Fig. 1, each phase of the PM-ANPC converter is comprised of three 3L-ANPC legs. In each 3L-ANPC leg, the low-frequency (LF) S_{1-Li} , S_{2-Li} , S_{5-Li} , S_{6-Li} power devices commute at the grid fundamental frequency whereas the high-frequency (HF) S_{3-Li} , S_{4-Li}

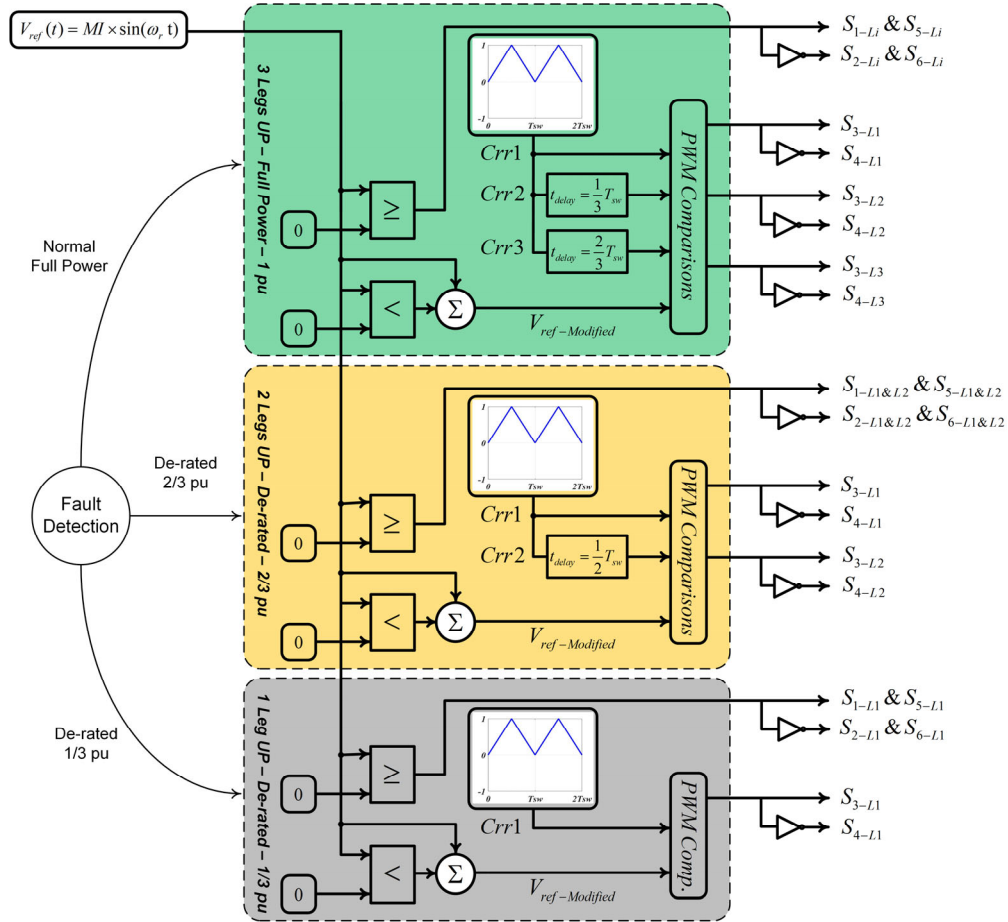

Fig. 2. The proposed variable phase-shift interleaved modulation method for one phase of the de-rated PM-ANPC converter.

power switches operate at switching frequency. Moreover, the leg inductors L_f are utilized to limit the circulating current between the 3L-ANPC legs.

In order to achieve equal current sharing between the parallel-connected 3L-ANPC legs, the interleaved modulation method has been employed in the PM-ANPC converter. Moreover, not only does the applied switching technique decouple the LF and HF switching signals, but also it only uses one carrier signal for each leg which simplifies utilizing variable phase-shift interleaved into the proposed de-rated PM-ANPC converter.

B. The proposed variable phase-shift interleaved modulation method for the de-rated PM-ANPC converter

As introduced and discussed in [18], [23], the output voltage of the PM-ANPC converter has $2n+1$ levels and the first switching harmonic frequency of the output voltage is shifted to $n \cdot f_{sw}$ by interleaving the carrier signals by T_{sw}/n where f_{sw} is the switching frequency, $T_{sw} = 1/f_{sw}$, and n is the number of active parallel legs.

The proposed variable phase-shift interleaved modulation method is presented in Fig. 2. As shown in Fig. 2, the value of applied phase-shift depends on the number of active 3L-ANPC legs. The fault detection algorithm provides the number of active legs (n) and the modulation method extracts the required interleaving phase-shift between the active legs. In normal operation mode in

which there are three active 3L-ANPC legs, the interleaving phase-shift (t_{delay}) between the legs is $T_{sw}/3$, the number of output voltage levels is seven, and the PM-ANPC is capable of delivering full power to the load. In case of a fault in one leg, the number of active legs is two, thus the interleaving phase-shift between the active legs is $T_{sw}/2$, the number of output voltage levels is five, and the de-rated PM-ANPC power is $2/3 pu$. In case of fault in two legs, there is only one active 3L-ANPC leg, the number of output voltage levels is three, and the de-rated PM-ANPC power is $1/3 pu$. In this paper, simultaneous failure occurrence in 2 or 3 parallel connected legs is considered as the entire converter failure. Therefore, the output power of the converter is limited to three states of $1 pu$, $2/3 pu$ and $0 pu$. This is due to the fact that the probability of failure in 2 or 3 legs at the same time is very small, and thus, these states can be simplified into a single state. However, in general, each state can be independently modeled. In the next section, the proposed reliability model for the converter with de-rated and redundant operation is presented.

III. PROPOSED RELIABILITY MODELING APPROACH

There are different measures for reliability evaluation in power converters [7]. The most traditional reliability measure for power converters is Mean Time To Failure (MTTF), which is the expected time to failure. This measure is equivalent to the reciprocal of the failure rate within the useful lifetime. This measure is traditionally

used as a rule of thumb for fast decision makings. Later, the L_x lifetime index is introduced that indicates the period that x % of the population is failed or the probability of survival after L_x is $(100 - x)$ %. This measure is attributed to the aging of the converter. It can be used for accurate end-of-life prediction and hence for design purposes. Most accurately, the survival function or failure rate function over a time period can be used as a measure of converter reliability.

The above-mentioned measures are taken into account the failure rate of the converter. However, in practice, the converters are repairable/maintainable. Therefore, after a failure occurrence, the converter can be repaired or failed parts of the converter can be replaced and returned to operation. As a result, another measure is introduced which takes into account both failure frequency and maintainability. This measure is called availability. Since converters in most of the applications are repairable, the availability measure is adopted in this paper. The availability at load level L_i can be calculated using (1) where λ and μ are the failure and repair rates consequently. $A(L_i)$ shows the probability that the converter is in operating mode as shown in Fig. 3(a). The failure rate of a converter consisting of Q components can be obtained by (2). Various approaches are available to find the failure rate of components [5]. In this paper, the MIL-HDBK 217 model showing the relation between the failure rate of power switches and junction temperature as in (3) is employed.

$$A(L_i) = \frac{\mu}{\mu + \lambda(L_i)} \quad (1)$$

$$\lambda(L_i) = \sum_{q=1}^Q \lambda_q(L_i) \quad (2)$$

$$\lambda_q(L_i) = \alpha \lambda_b \exp \left\{ -A \times \left(\frac{1}{T_{j,q}(L_i) + 273} - \frac{1}{\beta} \right) \right\} \quad (3)$$

Without losing the generality, the converter shown in Fig. 1 is used for modeling but, it can be generalized for any type of converters especially modular converters with redundant structures. It is considered that each phase will support full power if all legs are operating (state S1 in Fig. 3(b)). If one leg fails, the converter will be operated in de-rated mode with $2/3 pu$ power as state S2 in Fig. 3(b). If two or three legs fail, the converter will shut down with $0 pu$ power as state S3 in Fig. 3(b)). Considering the availability of each leg to be $A(L_i)$ at the load level of L_i , the probability of each state can be obtained as summarized in TABLE I.

The converter will support full power, if and only if all legs of all phases are available as state T1 shown in Fig. 3(c). If one, two or three phases operate in de-rated mode, the converter will also operate in de-rated mode with $2/3 pu$ output power like T2 in Fig. 3(c). Having more than one leg failed in at least one phase led to converter failure as state T3 in Fig. 3(c). The probability of each state of the converter can thus be obtained as summarized in TABLE II.

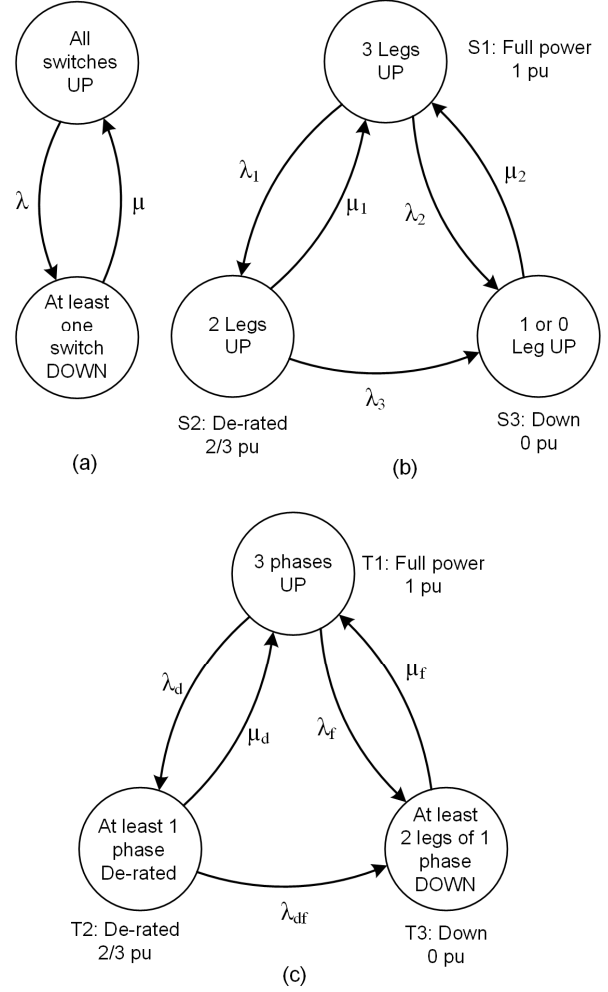

Fig. 3. State-space representation for reliability model of (a) one leg, (b) one phase with three legs, and (c) full converter.

TABLE I
RELIABILITY MODEL OF PHASE j WITH LOAD LEVEL L_i .

Phase state	Power level	State probability
Full power	1 pu	$S_1(L_i) = A(L_i)^3$
De-rated	2/3 pu	$S_2(L_i) = \begin{cases} 3A(L_i)^2(1 - A(L_i)) & L_i < \frac{2}{3} pu \\ 0 & L_i > \frac{2}{3} pu \end{cases}$
Down	0 pu	$S_3(L_i) = 1 - (S_1(L_i) + S_2(L_i))$

TABLE II
RELIABILITY MODEL OF A DE-RATED CONVERTER.

Converter state	Power level	State probability
Full power	1 pu	$T_1 = S_1^3$
De-rated	2/3 pu	$T_2 = 3S_1^2 S_2$
Down	0 pu	$T_3 = 1 - (T_1 + T_2)$

TABLE III
TOTAL RELIABILITY MODEL DE-RATED CONVERTER.

Load level	Load probability	Failure rate	Converter supportive state probability
L_1	p_1	λ_1	$g_1(L_1) = T_1(L_1) + T_2(L_1)$
L_2	p_2	λ_2	$g_2(L_2) = T_1(L_2) + T_2(L_2)$
\vdots	\vdots	\vdots	\vdots
L_k	p_k	λ_k	$g_k(L_k) = T_1(L_k) + T_2(L_k)$
L_{k+1}	p_{k+1}	λ_{k+1}	$g_{k+1}(L_{k+1}) = T_1(L_{k+1})$
\vdots	\vdots	\vdots	\vdots
L_n	p_n	λ_n	$g_n(L_n) = T_1(L_n)$

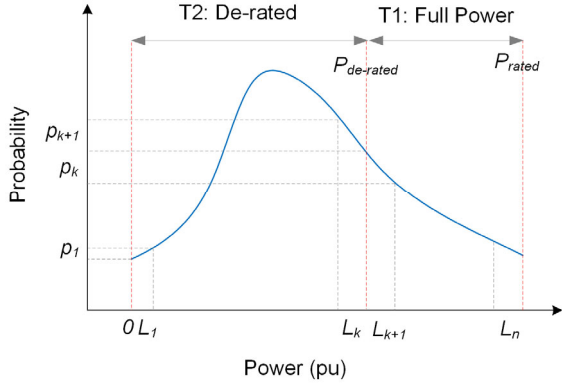

Fig. 4. Typical distribution of load profile.

Converter load profile can be presented by its probability density function, *pdf*, like the one shown in Fig. 4. The load levels and corresponding probabilities are summarized in TABLE VI in an ascending order. The converter failure rate for a given load level can be obtained by electrothermal modeling and (3).

Notably, this paper considers the power switches as the most failure-prone units, other components can be included in the failure rate similarly. It is assumed that $L_k < 2/3 pu < L_{k+1}$. Therefore, the load levels lower than L_k can be supported by both states T1 and T2 (full power and de-rated power). Meanwhile, the load levels higher than L_k are only supported by state T1. The converter supportive state probability for each load level is summarized in TABLE VI.

According to TABLE VI, the converter has different probabilistic behavior under various loading conditions. This is due to the fact that in redundant converters, some load levels can be supported even in de-rated, e.g., partially failed situations. Therefore, a mission profile-based availability measure is proposed to take into account the probabilistic characteristics of the converter under load change. According to this measure, the converter availability is predicted using (4), where $p_i(L_i)$ is the probability of load level L_i in the mission profile, and $g_i(L_i)$ is the probability of supportive state based on converter structure.

$$A_c = \sum_{i=1}^n p_i(L_i) \cdot g_i(L_i) \quad (4)$$

Besides availability, which is the probability of being in operation, a time-based reliability index can also be proposed using (5). This measure, which is called unavailability, indicates the number of hours per year that the converter is not operating due to the outage/failure in converters components.

$$U_c = 8760 \cdot \sum_{i=1}^n [1 - p_i(L_i) \cdot g_i(L_i)] \left[\frac{hr}{yr} \right] \quad (5)$$

IV. NUMERICAL ANALYSIS

In this section, first, the performance of the proposed control strategy for the operation of the converter under rated and de-rated conditions is illustrated. Afterward, the reliability analysis under different loading conditions is presented and the applicability of the proposed reliability model and index is demonstrated.

A. The proposed control scheme performance for de-rated operation

The presented PM-ANPC converter in Fig. 1 with de-rated functionality has been simulated in MATLAB/Simulink platform to evaluate the performance and viability of the PM-ANPC converter controlled by the proposed variable phase-shift interleaved modulation method. The parameters of the simulated system are presented in TABLE IV. One leg fault is applied to the PM-ANPC converter at $t = 0.1$ s.

The legs voltages and the output voltage of the de-rated PM-ANPC converter are presented in Fig. 5. As shown in Fig. 5, when a one leg fault is occurred in leg 3 at $t = 0.1$ s, the proposed variable phase-shift interleaved modulation method modifies the interleaving phase-shift from $t_{delay} = T_{sw}/3$ to $t_{delay} = T_{sw}/2$ to provide five-level voltage at the output of the de-rated PM-ANPC converter.

Fig. 6 depicts the legs currents and the output current of the PM-ANPC converter. As presented in Fig. 6, when a one leg fault is occurred in leg3 at $t = 0.1$ s, the proposed variable phase-shift interleaved modulation method modifies the interleaving phase-shift from $t_{delay} = T_{sw}/3$ to $t_{delay} = T_{sw}/2$ to provide power of $2/3 pu$ at the output of the de-rated PM-ANPC converter as well as keeping equal current sharing between remained two active legs.

TABLE IV
PARAMETERS OF THE SIMULATED PM-ANPC CONVERTER

Parameter	Value
Input DC-link voltage	$V_{dc} = 1000V$
AC grid frequency	$f_o = 60 Hz$
Switching frequency	$f_{sw} = 50 kHz$
Leg inductor	$L_f = 1mH$

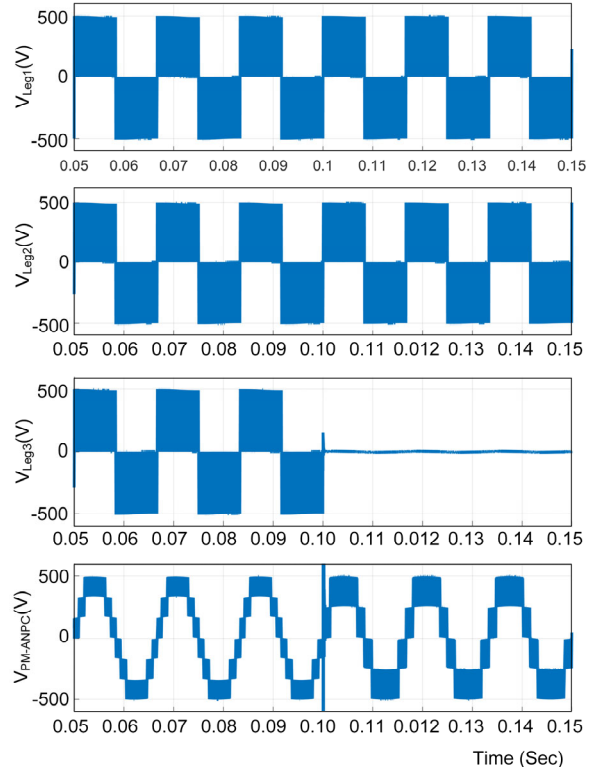

Fig. 5. The legs voltages and the output voltage of the de-rated PM-ANPC for one leg fault at $t = 0.1$ s.

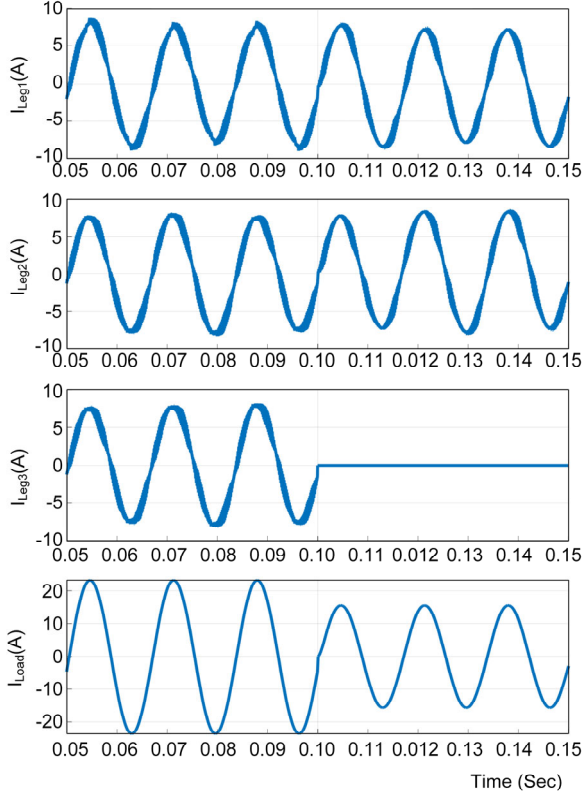

Fig. 6. The legs currents and the output current of the de-rated PM-ANPC for one leg fault at $t = 0.1$ s.

The provided simulation results verify the performance and feasibility of the proposed variable phase-shift interleaved modulation method for the de-rated PM-ANPC converter under faulty conditions.

B. The reliability analysis results for the de-rated redundant operation

The reliability of three-phase three-leg redundant ANPC converter shown in Fig. 1 is modeled using the proposed reliability measure. Three loading profiles are considered as shown in Fig. 7. These loads have the same peak power, while they have different distribution functions. The *pdf* and *cdf* functions of load profiles are shown in Fig. 8. For loads 1, 2, and 3, the de-rated converter can support respectively 65%, 53% and 81% of annual load. Therefore, the converter operation states will be different for the given load profiles.

Four approaches are employed to predict the unavailability of the converter as its reliability measure. The first one is based on the failure rate at the rated condition. In the second approach, the failure rate of the rated power is used for the load power higher than $2/3 pu$ and the failure rate of the de-rated state is used for the load power lower than $2/3 pu$. The third approach is based on the average failure rate that is commonly used in power systems. This is more practical since the failure rates of a unit are monitored within several years under different operating conditions and the average failure rate is then employed for system reliability modeling [24]. Finally, the proposed scheme uses the failure rates which correspond to the actual loading of the converter.

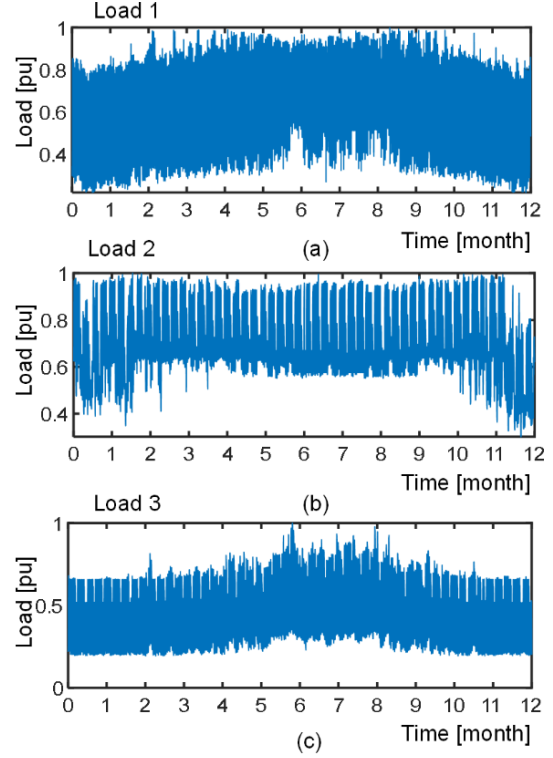

Fig. 7. The mission profile of three loading conditions.

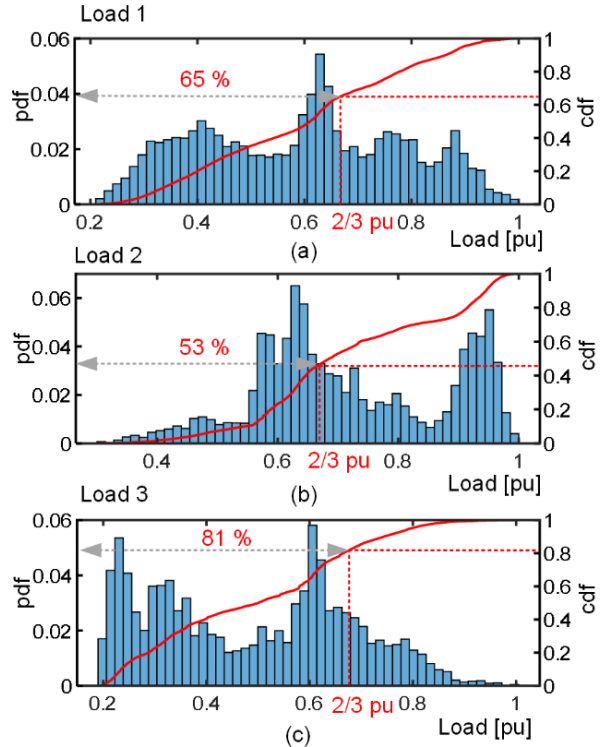

Fig. 8. Distribution of load profiles in Fig. 7.

TABLE V
IMPACT OF MISSION PROFILE ON THE CONVERTER
UNAVAILABILITY [hr/yr] – REPAIR RATE: $\mu = 36 yr^{-1}$

Mission profile	Using nominal failure rate	Using nominal and de-rated failure rate	Using average failure rate	Proposed approach
Load 1	39.6	25.1	25.5	18.4
Load 2	60.7	44.3	44.5	36.9
Load 3	22.5	8.9	13	3.5

The converter unavailability in *hr/yr* is summarized in TABLE V. It is assumed that after a failure occurrence, it takes on average 10 days to maintain the system availability, i.e., $\mu = 36 \text{ yr}^{-1}$. It is obvious that using the proposed modeling approach results in lower converter unavailability compared to the other approaches. Therefore, the outcomes of this analysis can be summarized as follows:

- **Impact of mission profile:** the converter unavailability as a measure of its reliability remarkably depends on its loading profile as reported in TABLE V. This is of high importance for the optimal design of redundant converters and their operation as well as planning for maintenance strategies. In other words, the converter is unavailable for on average 22.5 *hr/yr* under Load 3, while it is unavailable for 60.7 *hr/yr* under Load 2. If one sets the acceptable unavailability level to be, e.g., 25 *hr/yr*, then the converter with the designed structure is reliable for Load 3, while it is unreliable for Load 1 and 2. Thus, any efforts for design improvement and/or maintenance are necessary for applications like Load 1 and 2, however, for Load 3, the system is reliable enough.
- **Impact of modeling approach:** employing failure rate of a rated condition, using de-rated model failure rate and/ or average failure rate (the practical one) respectively induces higher unreliability compared to the actual failure rate corresponding to the loading conditions. Therefore, system analysis, e.g., system-level design and planning based on those approaches will be more conservative and may introduce higher design or maintenance costs. For instance, if the maximum unavailability is set to 25 *hr/yr*, according to TABLE V, the converter for applications having load profiles like Loads 1 and 2, needs either design improvement or maintenance if conventional modeling approaches are employed. However, with having a load-dependent modeling approach, i.e., the proposed method, only Load 2 needs design improvement, as its unavailability is higher than 25 *hr/yr* according to TABLE V.

Moreover, the converter unavailability under Load 3 using the proposed approach is much smaller than other approaches. This is due to the fact the distribution of Load 2 under 2/3 *pu* is 81% of the total load. This means, if the one leg in each phase of converter failures, the converter can still support 81 % of the load. As a result, the converter reliability under this load profile should be much better Load 1 and Load 2 as their distribution under 2/3 *pu* is almost equal to that of higher than 2/3 *pu*. This shows that conventional reliability measures using rated values cannot accurately model the converter unavailability. That is the reason that the converter unavailability under Load 2 using the proposed approach is 3.5 *hr/yr*, while using other methods, it is at least three times higher as reported in TABLE V. Therefore, the proposed method is more load-dependent and can offer a better estimate of converter reliability to optimize the planning decision-

In the second case, it is assumed that the converter is not operating in the redundant mode, thus the failure of any switches leads to converter shut down. The converter unreliability is predicted and summarized in TABLE VI. First, the converter unreliability is remarkably higher than the redundant operation. These results show that even having one redundant leg facilitating the de-rated making operation of the converter can considerably improve the system reliability. This fact even becomes more severe when the load distribution under 2/3 *pu*, i.e., the de-rated state, is high. For instance, as shown in Fig. 8(c), for load 3, 81% of the time the converter is operating under 2/3 *pu*. Therefore, if the converter operates in the de-rated mode after failure occurrence in one leg, the overall unavailability will become 3.5 *hr/yr* as given in TABLE VI. However, without a redundant leg for de-rated operation, the converter unavailability is 65.2 *hr/yr*, which is 20 times higher. Meanwhile, for loads 1 and 2 this is almost 3 times due to the fact that the converter operated at de-rated mode for 65% and 53% of the time as shown in Fig. 8(a and b).

Furthermore, as summarized in TABLE VI, the converter unreliability in non-redundant operation mode is less sensitive to the loading conditions. Thus, the conventional approaches without considering load profile can be used for non-de-rated converters with small calculation errors. However, for the de-rated operation mode, the results are varying and this also shows the necessity of a modeling approach for de-rated converters.

Moreover, the impact of maintenance/repair rate on the converter unreliability is illustrated in Fig. 9. This figure provides proper insight into converter performance that can be used for asset management in large-scale power electronics systems. By increasing the repair rate, the converter unavailability is decreased. This is due to the fact that the faster repair process maintains the system's availability.

The converter maintenance period depends on its application, consequently loading conditions. For instance, if the unreliability of 35 *hr/yr* is set as the maximum unreliability level, the maintenance planning and activities for the load 1 can be performed in 18.2 days, for the load 2 in 9.6 days. This means, the maintenance scheduling is more crucial for load 2. Therefore, appropriate actions must be done to reduce the repair time for load 2, such as having proper spare units, prepared maintenance personnel, etc.

Moreover, if a maintenance time of 18.2 days is planned for each load, the converter unavailability for the load 1, 2, and 3 will be 35, 65, and 8 *hr/yr* respectively as shown in Fig. 9. Therefore, in a power electronic system with various converters with different applications, applying a similar maintenance strategy cannot guarantee the desired performance of the system.

TABLE VI
IMPACT OF REDUNDANCY ON THE CONVERTER UNAVAILABILITY [*hr/yr*] USING PROPOSED APPROACH – REPAIR RATE: $\mu = 36 \text{ yr}^{-1}$

Mission profile	Redundant structure	Non-redundant structure
Load 1	18.4	72.4
Load 2	36.9	82.1
Load 3	3.5	65.2

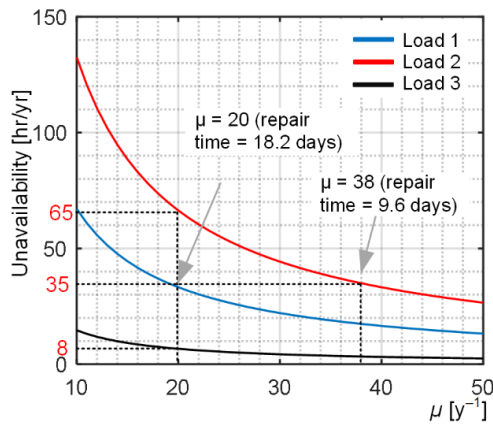

Fig. 9. Impact of repair rate μ on the converter unavailability.

V. CONCLUSION

This paper proposed a reliability modeling approach and availability-based reliability index for redundant power converters with the possibility of de-rated operation. This method is suitable for redundant structures, especially for modular multi-level converters where redundant operation can inherently be possible. The proposed model can be used for the design and operation of various redundancy capabilities of power converters under specified reliability expectations. The proposed approach takes into account the operating conditions' impact on the failure rate and consequently on the reliability of the converter. The numerical analysis indicated the necessity of the load-dependent modeling approach for de-rated converters. The obtained results showed that the conventional approaches are more conservative in reliability prediction, hence decision-making based on them will induce higher operational and maintenance costs. Moreover, it has shown that the performance of a redundant converter depends on its loading conditions, and operating in de-rated mode can improve the reliability 3-20 times depending on the loading profile. Furthermore, the proposed method can provide load-dependent maintenance time depending on the reliability expectations.

REFERENCES

- [1] H. E. Johan, G. W. Steven, and H. Ramtin, "Third EGrid Workshop Maps the Grid of the Future: Attendees Engage to Examine the Role of Power Electronic Applications in Modern Electric Power Systems," *IEEE Power Electron. Mag.*, vol. 6, no. 1, pp. 48–55, 2019.
- [2] M. Sandelic, S. Peyghami, A. Sangwongwanich, and F. Blaabjerg, "Reliability Aspects in Microgrid Design and Planning: Status and Power Electronics-Induced Challenges," *Renew. Sustain. Energy Rev.*, vol. 159, no. 112127, pp. 1–17, 2022.
- [3] S. Peyghami, P. Davari, and F. Blaabjerg, "System-Level Reliability-Oriented Power Sharing Strategy for DC Power Systems," *IEEE Trans. Ind. Appl.*, vol. 55, no. 5, pp. 4865–4875, 2019.
- [4] K. Ma, H. Wang, and F. Blaabjerg, "New Approaches to Reliability Assessment: Using Physics-of-Failure for Prediction and Design in Power Electronics Systems," *IEEE Power Electron. Mag.*, vol. 3, no. 4, pp. 28–41, 2016.
- [5] S. Peyghami, Z. Wang, and F. Blaabjerg, "A Guideline for Reliability Prediction in Power Electronic Converters," *IEEE Trans. Power Electron.*, vol. 35, no. 10, pp. 10958–10968, 2020.
- [6] F. Costa, "Failure Analysis of the Dc-Dc Converter: A Comprehensive Survey of Faults and Solutions for Improving Reliability," *IEEE Power Electron. Mag.*, vol. 5, no. 4, pp. 42–51, 2018.
- [7] S. Peyghami, F. Blaabjerg, and P. Palensky, "Incorporating Power Electronic Converters Reliability into Modern Power System Reliability Analysis," *IEEE J. Emerg. Sel. Top. Power Electron.*, vol. 9, no. 2, pp. 1668–1681, 2021.
- [8] S. Peyghami, P. Palensky, M. Fotuhi-Firuzabad, and F. Blaabjerg, "System-Level Design for Reliability and Maintenance Scheduling in Modern Power Electronic-Based Power Systems," *IEEE Open Access J. Power Energy*, vol. 7, pp. 414–429, 2020.
- [9] H. Wang, K. Ma, and F. Blaabjerg, "Design for Reliability of Power Electronic Systems," in *Proc. IEEE IECON*, 2012, pp. 33–44.
- [10] M. Ciappa, F. Carbognani, P. Cova, and W. Fichtner, "Lifetime Prediction and Design of Reliability Tests for High-Power Devices in Automotive Applications," *IEEE Int. Reliab. Phys. Symp. Proc.*, vol. 2003-Jan, no. 4, pp. 523–528, 2003.
- [11] I. F. Kovačević, U. Drofenik, and J. W. Kolar, "New Physical Model for Lifetime Estimation of Power Modules," *2010 Int. Power Electron. Conf. - ECCE Asia - IPEC 2010*, pp. 2106–2114, 2010.
- [12] N. C. Sintamarean, F. Blaabjerg, H. Wang, F. Iannuzzo, and P. De Place Rimmen, "Reliability Oriented Design Tool for the New Generation of Grid Connected PV-Inverters," *IEEE Trans. Power Electron.*, vol. 30, no. 5, pp. 2635–2644, 2015.
- [13] S. Peyghami, P. Davari, H. Wang, and F. Blaabjerg, "The Impact of Topology and Mission Profile on the Reliability of Boost-Type Converters in PV Applications," in *Proc. IEEE COMPEL*, 2018, pp. 1–8.
- [14] S. Li and L. Xu, "Strategies of Fault Tolerant Operation for Three-Level PWM Inverters," *IEEE Trans. Power Electron.*, vol. 21, no. 4, pp. 933–940, 2006.
- [15] S. Ceballos, J. Pou, J. Zaragoza, E. Robles, J. L. Villate, and J. L. Martín, "Fault-Tolerant Neutral-Point-Clamped Converter Solutions Based on Including a Fourth Resonant Leg," *IEEE Trans. Ind. Electron.*, vol. 58, no. 6, pp. 2293–2303, 2011.
- [16] W. Zhang, D. Xu, P. N. Enjeti, H. Li, J. T. Hawke, and H. S. Krishnamoorthy, "Survey on Fault-Tolerant Techniques for Power Electronic Converters," *IEEE Trans. Power Electron.*, vol. 29, no. 12, pp. 6319–6331, Dec. 2014.
- [17] P. Lezana, J. Pou, T. A. Meynard, J. Rodriguez, S. Ceballos, and F. Richardeau, "Survey on Fault Operation on Multilevel Inverters," *IEEE Trans. Ind. Electron.*, vol. 57, no. 7, pp. 2207–2218, 2010.
- [18] M. Abarzadeh, W. A. Khan, N. Weise, K. Al-Haddad, and A. M. El-Refai, "A New Configuration of Paralleled Modular ANPC Multilevel Converter Controlled by an Improved Modulation Method for 1 MHz, 1 MW EV Charger," *IEEE Trans. Ind. Appl.*, vol. 57, no. 3, pp. 3164–3178, 2021.
- [19] N. Rashidi-Rad, A. Rahmati, and A. Abrishamifard, "Comparison of Reliability in Modular Multilevel Inverters," *Prz. Elektrotechniczny*, vol. 88, no. 1 B, pp. 268–272, 2012.
- [20] J. V. M. Farias, A. F. Cupertino, V. D. N. Ferreira, H. A. Pereira, S. I. Seleme, and R. Teodorescu, "Reliability-Oriented Design of Modular Multilevel Converters for Medium-Voltage STATCOM," *IEEE Trans. Ind. Electron.*, vol. 67, no. 8, pp. 6206–6214, 2020.
- [21] Y. Zhang, H. Wang, Z. Wang, F. Blaabjerg, and M. Saeedifard, "Mission Profile-Based System-Level Reliability Prediction Method for Modular Multilevel Converters," *IEEE Trans. Power Electron.*, vol. 35, no. 7, pp. 6916–6930, 2020.
- [22] "IEC TR 62380: Reliability Data Handbook-Universal Model for Reliability Prediction of Electronics Components, PCBs and Equipment," 2006.
- [23] M. Abarzadeh, N. Weise, and S. Caron, "A Generalized Scalable Configuration of Hybrid 'Si+SiC' Paralleled Modular ANPC Converter," *Conf. Proc. - IEEE Appl. Power Electron. Conf. Expo. - APEC*, pp. 2791–2797, 2021.
- [24] R. Billinton and R. N. Allan, "Reliability Evaluation of Power Systems," First. New York: Plenum Press, 1984.