



**AALBORG UNIVERSITY**  
DENMARK

**Aalborg Universitet**

## **Controlling a Pandemic**

*An Account of Successfully Applying Control Theory to the Covid-19 Pandemic in Denmark  
[Applications of Control]*

Stoustrup, Jakob

*Published in:*  
IEEE Control Systems Magazine

*DOI (link to publication from Publisher):*  
[10.1109/MCS.2023.3273525](https://doi.org/10.1109/MCS.2023.3273525)

*Creative Commons License*  
CC BY 4.0

*Publication date:*  
2023

*Document Version*  
Accepted author manuscript, peer reviewed version

[Link to publication from Aalborg University](#)

*Citation for published version (APA):*  
Stoustrup, J. (2023). Controlling a Pandemic: An Account of Successfully Applying Control Theory to the Covid-19 Pandemic in Denmark [Applications of Control]. *IEEE Control Systems Magazine*, 43(4), 23-32.  
<https://doi.org/10.1109/MCS.2023.3273525>

### **General rights**

Copyright and moral rights for the publications made accessible in the public portal are retained by the authors and/or other copyright owners and it is a condition of accessing publications that users recognise and abide by the legal requirements associated with these rights.

- Users may download and print one copy of any publication from the public portal for the purpose of private study or research.
- You may not further distribute the material or use it for any profit-making activity or commercial gain
- You may freely distribute the URL identifying the publication in the public portal -

### **Take down policy**

If you believe that this document breaches copyright please contact us at [vbn@aub.aau.dk](mailto:vbn@aub.aau.dk) providing details, and we will remove access to the work immediately and investigate your claim.

# Controlling a Pandemic

## AN ACCOUNT OF SUCCESSFULLY APPLYING CONTROL THEORY TO THE COVID-19 PANDEMIC IN DENMARK

Jakob Stoustrup  
Aalborg University, Denmark, Email: jakob@es.aau.dk

### Summary

This article describes how the Danish response to the COVID-19 pandemic was established as a collaboration between authorities and experts, including control experts. In particular, it describes how a decentralized feedback scheme facilitated lifting societal constraints in a short period of time, while still keeping excess mortality at a significantly low level.

The contagious coronavirus disease 2019 (COVID-19) caused by the severe acute respiratory syndrome coronavirus 2 (SARS-CoV-2) was identified in Wuhan, China in December 2019. Observing the virus spreading rapidly to other countries across the world led the World Health Organization (WHO) to declare a Public Health Emergency of International Concern on January 30, 2020 and to characterize the outbreak as a pandemic on March 11, 2020. In response to the WHO warnings, each country across the world had to design a strategy to mitigate the consequences of the pandemic. At the time, there was no recent experience with a pandemic of this kind, and several different strategies were pursued. Most strategies focused on reducing mortality caused directly by COVID-19 and on avoiding overload on critical health infrastructure. Figure 1 in Sidebar *Excess mortality in EU* shows the number of cumulative deaths from all causes compared to projection, based on previous years for the member countries of the European Union (excluding Cyprus and Luxembourg, both with less than 1.5 million inhabitants). For data, please refer to [1]. As can be seen from the plot, excess mortality varies significantly across the EU countries. It should be emphasized that the different strategies applied

by the EU countries are just one among several reasons for the diversity of the observed data. Demography, social conditions, health infrastructure, and several other factors should be taken into account to fully understand the data shown in the figure. As can be seen from Figure 1, Denmark has significantly less cumulative deaths from all causes, compared to projection based on previous years, in comparison with the other countries in the figure. The mitigation strategy pursued by the government of Denmark during the initial part of the pandemic was in part inspired by control theory. This strategy is described briefly below. This article does not pretend to present novel control strategies or solutions, but rather to offer some practical lessons learned from applying known methodologies on societal-scale problems. As Denmark was one among very few countries where the national strategy for mitigating COVID-19 was based on an automated feedback strategy, the author would like to share some of the experience on how the controls community can collaborate with authorities in the interest of society. This is highly challenging, especially when solutions with critical implications for a whole nation have to be found literally in a matter of a few days, and the approach to implementation has to be very pragmatic.

### CONTROL APPROACHES TO COVID-19 MITIGATION

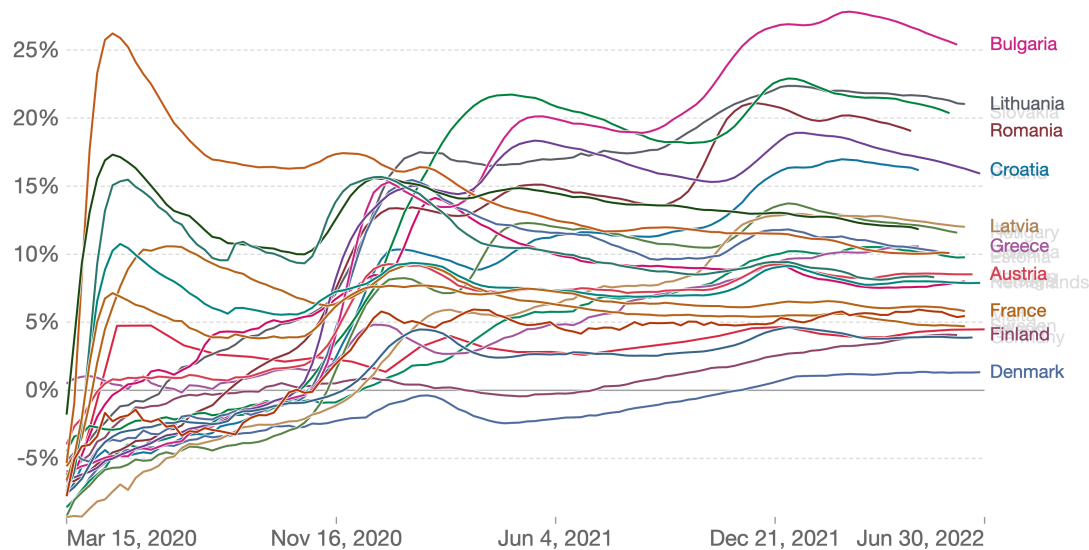
Using control theory to mitigate the effect of epidemic diseases is not new. An early reference that discusses the possibility is [2]. In [3], controlling epidemics using optimal control is discussed. However, since the outbreak of COVID-19, the advanced controls community has produced a significant number of contributions on the topic of mitigating the spread of this specific disease. In the sequel,

## Excess mortality in EU

### Excess mortality: Cumulative deaths from all causes compared to projection based on previous years

Our World in Data

The percentage difference between the cumulative number of deaths since 1 January 2020 and the cumulative projected deaths for the same period based on previous years. The reported number might not count all deaths that occurred due to incomplete coverage and delays in reporting.



Source: Human Mortality Database (2022), World Mortality Dataset (2022)

OurWorldInData.org/coronavirus · CC BY

Note: Comparisons across countries are affected by differences in the completeness of death reporting. Details can be found at our Excess Mortality page.

**Figure 1** Excess mortality in EU during first two years of the pandemic (Luxembourg and Cyprus are excluded). Source: Our World in Data.

we shall mention a select few of these contributions, but encourage the reader to search for more in the vast amount of literature, also those published since the submission of this manuscript. An initial discussion of the topic can be found in [4] that provides an overview on how various control approaches can be used to either mitigate or suppress the spread of COVID-19. A more detailed discussion on the use of NPIs can be found in [5] that specifically addresses the issue of shortage of ICU beds as a control objective. A major challenge in controlling COVID-19 and other epidemics is the latency in detection (see below). The recent article [6] introduces a model with transmission delays for control. This paper was based on a request for a national reopening plan. Some of the considerations to that end can be found in [7]. A recent discussion on how to use feedback control strategies for policy management can be found in [8].

### THE DANISH APPROACH TO COVID-19 MITIGATION

The Danish response to COVID-19 was initiated on the date, where WHO announced the disease as a pandemic on March 11, 2020. The prime minister called for a press conference, announcing a number of recommendations and restrictions, most of which took immediate action. The recommendations and restrictions were devised based on advice from the Danish Department of Health and the Danish Health Authority. Restrictions included closing schools and universities, as well as indoor cultural institutions. Employees of the public sector with non-critical functions were sent home. Vulnerable citizens were encouraged to stay at home. In subsequent months, several other restrictions and recommendations were added. In Denmark, the term “lockdown” was used as a vague term for a number of restrictions and recommendations issued at a given time. The same term is used below, but with the specific meaning of the term provided by

the context. Later in 2020, the Danish government agreed with the Danish parliament on a process for adjusting the COVID-19 restrictions and recommendations in response to the continuous development of the pandemic. In particular, the government agreed to consult an independent scientific reference group of experts prior to changes in the mitigation tactics. Subsequently, a total of 12 experts were appointed to the *Scientific Reference Group for COVID-19*. The Scientific Reference Group included experts in virology, epidemiology, mathematical modeling, economics, and social science. Also, one expert in control theory (the author of the present article) was appointed to the Scientific Reference Group. At the time the Scientific Reference Group was appointed, a large number of restrictions and recommendations were already in place in Denmark. Therefore, one of the first assignments of the Scientific Reference Group was to devise a strategy to alleviate some of the restrictions and recommendations in anticipation of a future reduced level of COVID-19 infections. In their work, the Scientific Reference Group assessed current restrictions and recommendations based on four criteria:

- 1) *Spread of disease*: How does a certain restriction/recommendation influence the growth rate of the number of infections?
- 2) *National economy*: How does a certain restriction/recommendation influence turn-over for private companies, public expenses, and other measures related to gross national product (GNP)?
- 3) *Public health and well-being*: How does a certain restriction/recommendation influence the physical and mental health of the population and the well-being of afflicted citizens?
- 4) *Personal freedom*: How does a certain restriction/recommendation influence the individual feeling of freedom, understood as a liberal right?

As part of the work of the Scientific Reference Group, each of these four criteria were quantified for the societal-level interventions in place at the time. The resulting quantification is illustrated in Figure 2. Please refer to [9] for details.

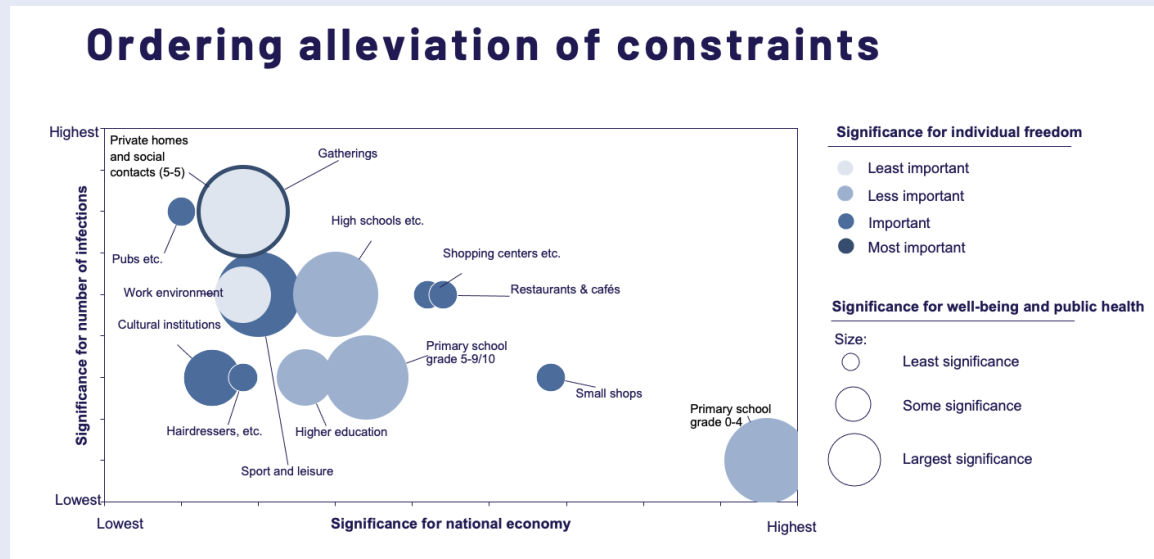
At the deadline of the first report from the Scientific Reference Group, restrictions and recommendations were in action in 13 societal domains. These 13 domains were analyzed with respect to the four criteria mentioned above. Based on this analysis, the Scientific Reference Group provided a number of recommendations for instating and lifting restrictions. A summary of this analysis is illustrated in Figure 2. The report was submitted and presented in the Danish Parliament in January 2021 (see [9]). Subsequent to the submission of the report by the Scientific Reference Group and its presentation, the Danish Parliament decided on a reopening strategy that closely followed the recommendations of the report. In the implementation of the strategy, a control-based approach was adopted. As the

overall reopening plan, the societal-level interventions in place were alleviated one by one, according to the partial ordering illustrated in Figure 2. The detailed administrative implementation was highly complex and outside the scope of this article. However, to eliminate the risk for an unacceptable outbreak of the disease, in parallel to the step-by-step alleviation of restrictions at the national level, a decentralized control scheme was applied at the level of parishes to mitigate local outbreaks and thereby control the aggregated national outbreak. Below, the decentralized control approach applied in Denmark in 2021 is described.

## DESIGN OF NON-PHARMACEUTICAL INTERVENTIONS AS A CONTROL PROBLEM

Controlling the spread of an infectious disease can, to some degree, be done by NPIs that influence the parameters of the SEIR model. In particular, it is possible to influence the disease transmission between individuals and, thus influence the social interaction. In the SEIR model described in Sidebar *Modeling epidemics*, social interaction is described by the  $\alpha_1, \alpha_2$  parameters. The available measurement signals for controlling the epidemic is based on estimating the number of infectious persons (based on available data), in particular, individual tests (antigene and PCR tests) fused with other available data sources (for example, waste water samples). These can be seen as semi-randomized samplings of the number of symptomatic/asymptomatic infectious,  $I_S$  and  $I_A$ , as explained in Sidebar *Modeling epidemics*. Based on an elaborate model (with radical higher complexity than the simple model shown in Sidebar *Modeling epidemics*), state and parameter estimation techniques were applied to yield satisfactory estimates of the reproduction number,  $R_0$ . The actual models applied, including full source code and documentation, can be found in [12]. The basic principle for controlling interventions for infectious diseases relies on increasing or decreasing the level of intervention to obtain a desired value  $R_{0,\text{ref}}$  of  $R_0$ . To stabilize the epidemic,  $R_{0,\text{ref}}$  should be strictly less than 1. On the other hand, to minimize the required interventions,  $R_{0,\text{ref}}$  should be chosen only marginally smaller than 1. The margin  $\varepsilon = 1 - R_{0,\text{ref}}$  should be chosen sufficiently small to minimize the required interventions. However,  $\varepsilon$  should also be sufficiently large to not compromise national healthcare capacity in general and intensive care unit (ICU) capacity, in particular, as the actual value of  $R_0$  varies around its reference value. Such a variation should be anticipated, due to the uncertainty in the model, uncertainty in measurements, and the delay from infections to observations. This delay is caused mainly by infectious individuals being tested positive only after a latency period, where symptoms develop. The delay is estimated to be in the range of 10-15 days. From a controls point of view, such a substantial delay poses some real challenges. The

## Ordering constraints



**Figure 2** Prioritized order of constraint alleviation. The Danish Scientific Reference Group for COVID-19 prioritized the existing restrictions and recommendation based on four criteria: spread of disease; national economy; public health and well-being; personal freedom. Source: original graphics.

implemented controller used a construct similar to a Smith predictor to accommodate this (see below). A first idea for control design could be to close a feedback loop around the national estimate of  $R_0$  to a national level of NPIs. This, however, would not work in practice, as the latency mentioned above could cause the epidemic to reach levels that would compromise national ICU capacity when NPIs were lifted before detected by the delayed measurements. In principle, this danger could be prevented by choosing  $\varepsilon$  sufficiently large. In practice though, infection levels in Denmark during the period considered were never small enough to allow for a sufficiently large  $\varepsilon$ . Instead, the intervention design for alleviating restrictions in Denmark was based on a decentralized control scheme. As simplified illustration is shown in Figure 3. The individual control loops are closed at the level of parishes, where a Danish parish in average has approximately 2.700 inhabitants. For each parish, the level of infections is measured. If the level is too high, more NPIs are applied. When the level drops sufficiently, NPIs are relieved. The threshold for admissible infection levels in parishes is adjusted at a national level based on the total number of infections. The main idea in applying a decentralized control scheme is that due to desynchronization of the individual control loops, overload of national health infrastructure capacity can be avoided. Even if a temporary exponential growth

of infections appears in one parish, the total number of citizens requiring hospitalization or ICU treatment will still be within the national healthcare capacity. This scheme only works if the dynamics between parishes would not have a tendency to synchronize. Luckily, it was known from data collected during 2020 that this assumption was valid. Infections between parishes relies on interregional transportation of individuals, and this was seen in the early phase to happen with slower dynamics than the local disease spread. Further, interregional transportation was nationally advised against. The actual parameters (measurements) used in the parish-level control loops were the following three:

- $r_I$ : The proportion of infectious within the parish population
- $r_{\text{PCR}}$ : The proportion of positive results from PCR testing
- $n_{\text{inf}}$ : The absolute number of new infections within the past seven days.

As described above, the threshold values for these three parameters varied with the total national level of disease. Example values were:  $r_I < 0.004$  (400 infectious pr. 100,000 inhabitants),  $r_{\text{PCR}} < 0.02$  (2% positive PCR tests), and  $n_{\text{inf}} < 20$  (20 total new infectious within the past seven days in the parish). A description (in Danish) of the

## Modeling epidemics

Infectious diseases, such as COVID-19, are often modeled through compartmental models, such as the so-called SEIR model (see, for example, [10]). In its simplest form, an SEIR model of infections spreading in a population of size  $N$  has only four states:

- $S$ : The number of **S**usceptible persons
- $E$ : The number of **E**xposed persons
- $I$ : The number of **I**nfectious persons
- $R$ : The number of **R**emoved persons (recovered/immune or deceased).

Here, “numbers” are understood as continuous variables. In this article, we shall use a slightly extended SEIR model that follows [11] and uses the parameters in that article. This model splits the number of infectious persons into asymptomatic infectious ( $I_A$ ) and asymptomatic infectious ( $I_S$ ). Further, it introduces the number of Pathogens ( $P$ ) as a state. With these variables, the SEIR model is given by:

$$\frac{dS}{dt} = b - \frac{\beta_1 SP}{1 + \alpha_1 P} - \frac{\beta_2 S(I_A + I_S)}{1 + \alpha_2(I_A + I_S)} + \psi E - \mu S$$

$$\frac{dE}{dt} = \frac{\beta_1 SP}{1 + \alpha_1 P} + \frac{\beta_2 S(I_A + I_S)}{1 + \alpha_2(I_A + I_S)} - \psi E - \mu E - \omega E$$

$$\frac{dI_A}{dt} = (1 - \delta)\omega E - (\mu + \sigma)I_A - \gamma_A I_A$$

$$\frac{dI_S}{dt} = \delta\omega E - (\mu + \sigma)I_S - \gamma_S I_S$$

$$\frac{dR}{dt} = \gamma_A I_A + \gamma_S I_S - \mu R$$

$$\frac{dP}{dt} = \eta_A I_A + \eta_S I_S - \mu_P P.$$

Please refer to [11] for the detailed explanation and numerical values of the parameters involved in the model. From a controls perspective (see below), the central figure is the so-called *basic reproduction number*. For a given infectious disease, the basic reproduction number,  $R_0$ , is the expected number of cases directly generated by one case in a population where all individu-

als are susceptible to infection. The basic reproduction number,  $R_0$ , is critical for the development of an infectious disease, as it can be shown (see [10]) that an epidemic is decreasing for  $R_0 < 1$  and, correspondingly, an epidemic is increasing for  $R_0 > 1$ . It can easily be shown that if all other parameters fixed, the reproduction number will be larger than one for sufficiently large  $\alpha_1, \alpha_2$  and smaller than one for sufficiently small  $\alpha_1, \alpha_2$ . These two parameters,  $\alpha_1, \alpha_2$ , are directly influenced by the NPIs described in this article and, thus, serve as control signals for the controllers discussed in this article. Introducing a control signal  $u$  in the  $\alpha_1, \alpha_2$  parameters of the SEIR model, the model takes the form:

$$\frac{dS}{dt} = b - \frac{\beta_1 SP}{1 + \alpha_1(u)P} - \frac{\beta_2 S(I_A + I_S)}{1 + \alpha_2(u)(I_A + I_S)} + \psi E - \mu S$$

$$\frac{dE}{dt} = \frac{\beta_1 SP}{1 + \alpha_1(u)P} + \frac{\beta_2 S(I_A + I_S)}{1 + \alpha_2(u)(I_A + I_S)} - \psi E - \mu E - \omega E$$

$$\frac{dI_A}{dt} = (1 - \delta)\omega E - (\mu + \sigma)I_A - \gamma_A I_A$$

$$\frac{dI_S}{dt} = \delta\omega E - (\mu + \sigma)I_S - \gamma_S I_S$$

$$\frac{dR}{dt} = \gamma_A I_A + \gamma_S I_S - \mu R$$

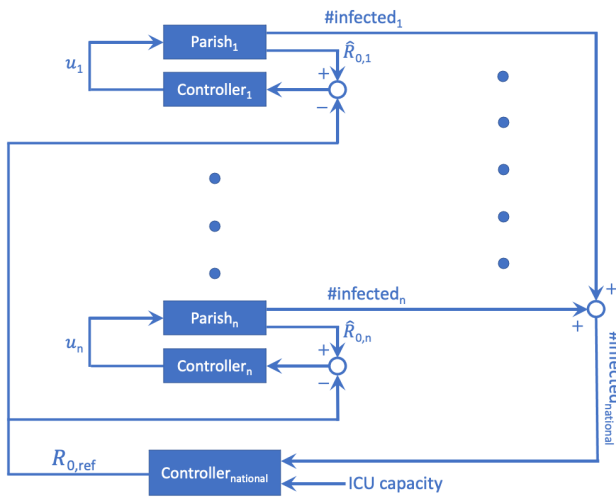
$$\frac{dP}{dt} = \eta_A I_A + \eta_S I_S - \mu_P P$$

$$y_m = \kappa_1 I_S + \kappa_2 I_A.$$

Thus, the control signal influences the two  $\alpha_{\{1,2\}}$  parameters, and thereby the reproduction number. The measurement  $y_m$  is aggregated from several sources, mainly from tests. Since self-initiated tests are predominantly done for symptomatic individuals, typically  $\kappa_1 \gg \kappa_2$ . The controller described in this article is not a model-based controller. The model, however, was crucial in understanding the dynamics of the spread of the disease, in making prognosis, and in validating the decentralized control approach that was implemented in Denmark in 2021.

applied model can be found in [13]. The specific values of the three thresholds were in part derived by model studies and in part by pragmatic considerations by the authorities in terms of the number of affected parishes. The thresholds were adjusted manually based on considerations of the aggregated infection numbers. The thresholds were adjusted three times during the period described in this article. To reduce any oscillatory behavior of the controller, the NPI decision was implemented with a dead-band. If a parish violated all three thresholds, a number of NPIs would be applied to that parish. The same NPIs were

subsequently lifted if the parish, in seven consecutive days, would have satisfied the thresholds for at least one of the three parameters. The specific NPIs applied in the case of violation of all three thresholds included closing primary schools, clubs, educational institutions, cultural activities, and sport activities. In addition, a number of behavioral recommendations were proposed to the citizens of the parish during the lockdown period. The decentralized controller is summarized in Sidebar *Decentralized controller*. In [4], it is argued that enabling or lifting NPIs gradually could make sense from a controls point of view. In the



**Figure 3** Simplified illustration of decentralized control scheme applied in Denmark. In each parish, NPIs are lifted if local  $R_0$  becomes smaller than  $R_{0,ref}$  and reinstated if local  $R_0$  becomes larger than  $R_{0,ref}$ .  $R_{0,ref}$  is adjusted nationally according to total number of infections. (Original graphics).

implementation in Denmark, however, for simplicity of administration, the full package of NPIs described in [13] were enabled/lifted simultaneously. The three threshold values,  $\bar{r}_I$ ,  $\bar{r}_{PCR}$ , and  $\bar{n}_{inf}$ , were adjusted in an outer loop according to the aggregated national level of infections. This was done manually and only a few times (three) during the first five-month duration of the control operation. In addition to the simplified structure illustrated in Figure 3, an intermediate control level was also in action at the level of municipalities. A Danish municipality in average has approximately 60,000 inhabitants. NPIs were introduced at the municipal level if a threshold for  $r_I$  was violated (example:  $r_I > 0.002$ , that is, 200 infectious pr. 100,000 inhabitants for the whole municipality). Subsequent lifting of NPIs at the municipal level was based on threshold compliance for seven consecutive days.

### SIMULATIONS OF CENTRALIZED AND DECENTRALIZED CONTROL SCHEMES

This section will present simulation results for the model described above, based on scenarios with no intervention, with a centralized control scheme, and with the decentralized control scheme described above, respectively. As the purpose of this article is to demonstrate the effect of control, we shall use the highly simplified model described in Sidebar *Modeling Epidemics*, and we shall counter-factually assume that the development of the disease is not affected by introduction of vaccine programs, appearance of new virus variants, or other external factors. The actual development in Denmark will be described in a separate

section below. First, the “open-loop” behavior that is, the epidemic behavior without any interventions, is shown in Figure 4. In this figure, it can be seen how during the five month period, almost the full Danish population of 5.8 million inhabitants are infected. Within a few weeks, the number of symptomatic infectious citizens are so high that both the hospital capacity in general and the ICU capacity in particular will be violated by orders of magnitude. Next, the simulation shown in Figure 5 demonstrates a shutdown/reopening algorithm operating at a national level. Whenever the total count of symptomatic individuals reaches an upper bound, national shutdown is executed. Similarly, when the symptomatic count reaches a lower bound, a reopening at national level is performed. Due to the latency in the disease, significant overshoots are seen in the figure. Due to this, the reopening windows are very short, compared to the shutdown periods, and reopening only takes place in 5.23% of the five-month period. The simulation shown in Figure 6 demonstrates the decentralized control algorithm described above. A total of 2,158 parishes are simulated with an average population of 2,700 inhabitants each. For each parish, a local lockdown is executed when the local symptomatic count passes an upper threshold. Similarly, the parish is reopened whenever the symptomatic count passes a lower threshold. Figure 6 shows the aggregate national count of symptomatic individuals. In contrast to the centralized algorithm, the reopening periods dominate, and the average citizen experiences reopening in 91.04% of the five-month period. The decline in symptomatic individuals over the timeframe is due to a decreasing number of susceptible individuals due to high exposure in individual parishes. Finally, Figure 7 shows the behavior in two individual parishes. In one parish, the initial infectious level is small enough that lockdown is never required. In the other parish, the upper thresholds are violated two times, causing two consecutive shutdowns and reopenings. It should be noted that the centralized and decentralized controllers that are simulated in this section are simple threshold controllers. The actual decentralized controller scheme that was decided by and implemented by the Danish authorities based on the recommendations of the Scientific Reference Group was more complex, as it had to meet requirements related to challenges in specific Danish parishes.

### RESULTS FROM IMPLEMENTATION OF DECENTRALIZED CONTROL SCHEME IN DENMARK

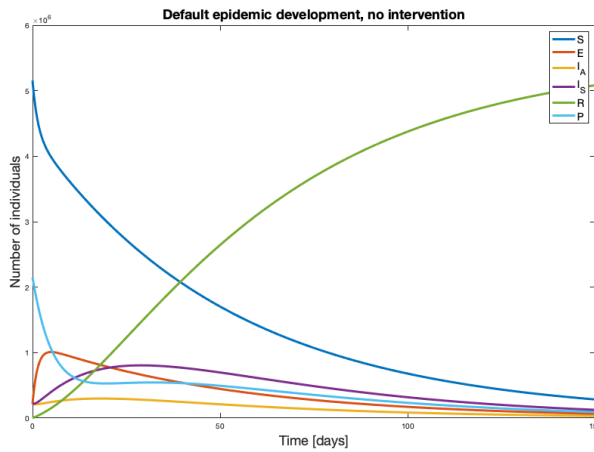
The mitigation scheme proposed by the Scientific Reference Group, including the decentralized control scheme described above, was implemented by March 31, 2021, see [13]. Figure 8 shows two examples of parishes that had a lockdown period in the month from May 11 to

## Decentralized controller

The decentralized control action for Parish # $i$  is:

$$u_i(t) = \begin{cases} \text{NPIs enabled, if } \exists \tau, 0 \leq \tau < 7 \text{ days:} \\ \quad r_{I,i}(t - \tau) > \bar{r}_I \text{ AND } r_{PCR,i}(t - \tau) > \bar{r}_{PCR} \\ \quad \text{AND } n_{inf,i}(t - \tau) > \bar{n}_{inf} \\ \text{NPIs lifted, if } \forall \tau, 0 < \tau \leq 7 \text{ days:} \\ \quad r_{I,i}(t - \tau) < \bar{r}_I \text{ OR } r_{PCR,i}(t - \tau) < \bar{r}_{PCR} \\ \quad \text{OR } n_{inf,i}(t - \tau) < \bar{n}_{inf} \end{cases}$$

The local control signals  $u_i(\cdot)$ ,  $i = 1, \dots, 2,158$  are logical variables enabling or lifting a number of NPIs, which influences the social interaction in Parish # $i$ , as described in the SEIR model above.

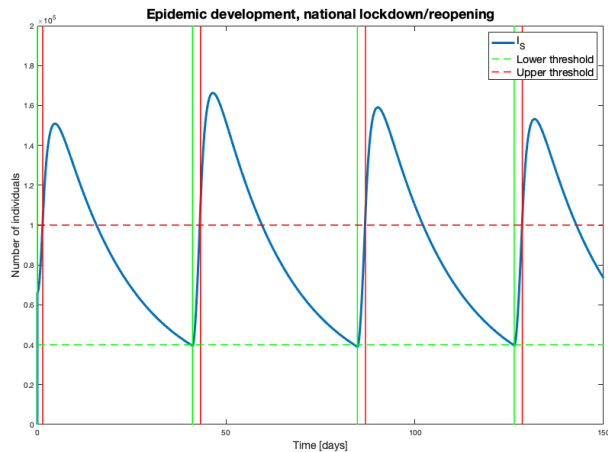


**Figure 4** Simulation of epidemic development assuming no interventions. The six curves illustrate the number of: Susceptible ( $S$ ), Exposed ( $E$ ), Asymptomatic Infectious ( $I_A$ ), Symptomatic Infections ( $I_S$ ), Recovered ( $R$ ), and Pathogens ( $P$ ), respectively.

June 10, 2021. The two parishes both had outbreaks that violated the three threshold values described above. It can be seen from the plots that the level of infection decreased for both parishes during the period where the additional NPIs from the controller was in action. In the period following the initialization of the new control scheme, it was observed that the local lockdowns in parishes had immediate desired effects. In general, most parishes were able to reopen after a short period of lockdown with very few exceptions. At a national level, only a slight increase in infection levels were seen, in spite of the substantial lifting of restrictions that was reported in international media. The development of the epidemic can be seen in Figure 9.

## CONCLUSIONS

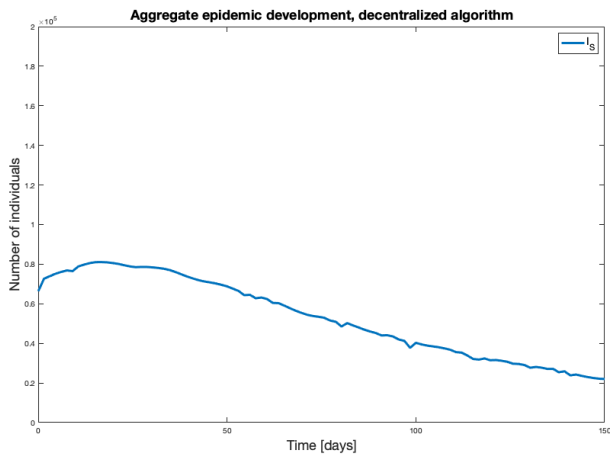
During the first years of the COVID-19 outbreak, governments across the world were continuously monitoring the situation in their countries and adjusting measures to mitigate the effects of the pandemic. The adaptation of



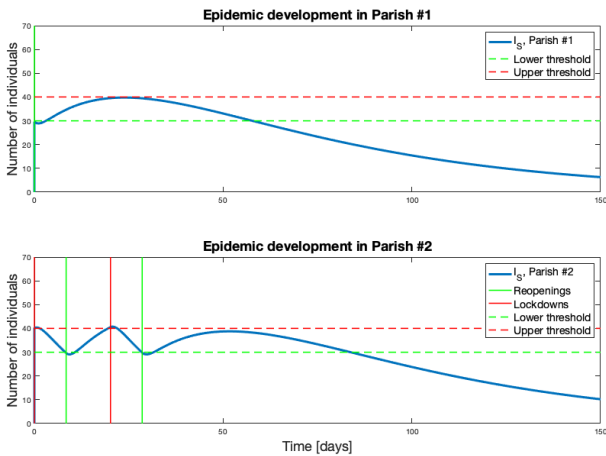
**Figure 5** Simulation of the number of symptomatic infected individuals under a central shutdown/reopening algorithm. Red vertical lines indicate a shutdown, green vertical lines a reopening. Horizontal dashed lines indicate lower/higher thresholds. Reopening is in effect 5.23% of the total duration.

NPIs in response to the development of the spreading of the disease could possibly be seen as an “informal” control loop. In contrast, the Danish government, based on advice from a Scientific Reference Group, decided to take a more formal control approach and introduced automated responses in a decentralized control scheme as part of the mitigation strategy. The data based on operating this strategy on 2,158 parishes for almost a year indicated that the decentralized control scheme had the desired effect. Indeed, by applying NPIs locally rather than at a national level, it was possible to reopen the Danish society much faster than compared to a slow uniform reopening. By introducing automated feedback acting on specific local information rather than on aggregated national information, the resulting controller bandwidth seems to have been significantly improved, as also demonstrated by the simulations of this article. Denmark had significantly less COVID-19 related mortality compared to several similar countries, and it cannot be ruled out that the applied



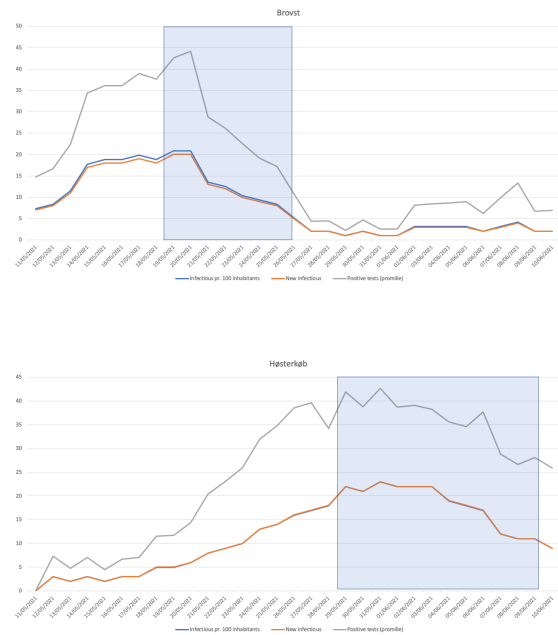


**Figure 6** Simulation of the number of symptomatic infected individuals under a decentral shutdown/reopening algorithm. The curve shows the number of symptomatic infectious, aggregated over a total of 2,158 parishes that has been simulated. Reopening is in effect 91.04% of the total duration in average over the parishes.



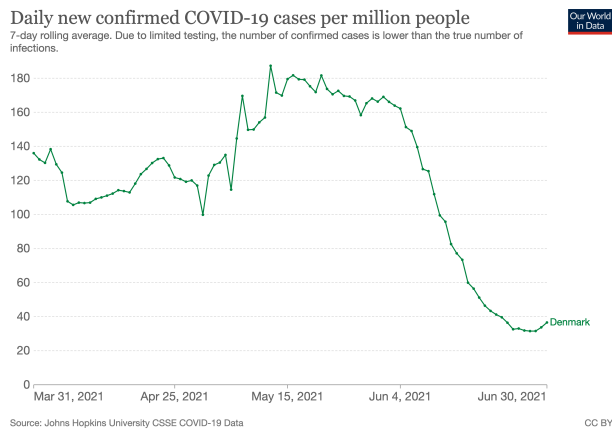
**Figure 7** Simulation of the number of symptomatic infected individuals under a decentral shutdown/reopening algorithm for two specific parishes, based on thresholds of 40 and 30, respectively. Red lines indicate a shutdown, green lines a reopening. Thus, Parish #2 has two shutdowns and two consecutive reopenings. Parish #1 remains open throughout the simulation, as the total count never violates the upper threshold.

feedback control scheme was one of the factors involved in this result. This article has focused on strategies for using NPIs as a means to mitigate effects of an epidemic. It should be emphasized, however, that many other factors are significant for the outcome of an epidemic. In particular, studies have shown that citizen compliance with government restrictions and recommendations have



**Figure 8** Local feedback in action. The figure shows two parishes that both have a lockdown during the month from May 11 to June 10, 2021. The three parameters for determining lockdown are shown: proportion of infectious,  $r_I$ , proportion of positive PCR tests,  $r_{PCR}$ , and the number of new infectious,  $n_{inf}$ . Shaded areas show the periods of lockdown. (Original graphics).

been highly correlated with the mortality of the COVID-19 pandemic (see, for example, [14] and references therein). To that end, the public compliance with restrictions and recommendations in Denmark was among the highest in the world. This in part has cultural reasons, but might also in part be related to the fact that the Scientific Reference Group continuously monitored the public consensus with the strategy via data from the HOPE Project, see [15], and this measurement of public consensus played an important role in the decision making. As an overall conclusion, the author would like to propose that the advanced controls community has strong potentials for close collaboration with authorities on critical societal challenges as the one illustrated in the case study of this article. A common precondition, however, is that the control scientists involved are willing to take a very pragmatic approach. Often, there will be no opportunity to implement flagship theoretical results, but rather simple-minded practical and pragmatic solutions as the one illustrated in this article. This leaves a dilemma for control theory in terms of the risk to appear either trivial or impractical to the general public. In a critical situation like the one caused by COVID-19, this is a very real choice that our community can be faced with.



**Figure 9** Total number of infections during the first three months of operation of decentralized controller. It can be seen that the substantial reopening causes only a modest increase in the level of infections. Source: Our World in Data.

## References

- [1] C. Giattino, H. Ritchie, M. Roser, E. Ortiz-Ospina, and J. Hasell, "Excess mortality during the coronavirus pandemic (COVID-19)," *Our World in Data*, 2022. [Online]. Available: <https://ourworldindata.org/excess-mortality-covid>
- [2] N. T. Bailey, "Macro-modelling and prediction of epidemic spread at community level," *Mathematical Modelling*, vol. 7, no. 5-8, pp. 689-717, 1986.
- [3] H. Behncke, "Optimal control of deterministic epidemics," *Optimal control applications and methods*, vol. 21, no. 6, pp. 269-285, 2000.
- [4] G. Stewart, K. Heusden, and G. A. Dumont, "How control theory can help us control COVID-19," *IEEE Spectrum*, vol. 57, no. 6, pp. 22-29, 2020.
- [5] N. M. Ferguson, D. Laydon, G. Nedjati-Gilani, N. Imai, K. Ainslie, M. Baguelin, S. Bhatia, A. Boonyasiri, Z. Cucunubá, G. Cuomo-Dannenburg *et al.*, "Impact of non-pharmaceutical interventions (NPIs) to reduce COVID-19 mortality and healthcare demand," 2020.
- [6] N. Hritonenko, O. Yatsenko, and Y. Yatsenko, "Model with transmission delays for covid-19 control: Theory and empirical assessment," *Journal of Public Economic Theory*, vol. 24, no. 5, pp. 1218-1244, 2022.
- [7] S. C. Anderson, N. Mulberry, A. M. Edwards, J. E. Stockdale, S. A. Iyaniwura, R. C. Falcao, M. C. Otterstatter, N. Z. Janjua, D. Coombs, and C. Colijn, "How much leeway is there to relax COVID-19 control measures?" *Epidemics*, vol. 35, p. 100453, 2021.
- [8] K. Narayan, H. Rathore, and F. Znidi, "Using epidemic modeling, machine learning and control feedback strategy for policy management of COVID-19," *IEEE Access*, vol. 10, pp. 98 244-98 258, 2022.
- [9] Danish Scientific Reference Group for COVID-19, "Assessment for reopening of the scientific reference group for COVID-19 (in Danish)," *The Danish Ministry of Health*, Jan. 2021. [Online]. Available: <https://bit.ly/3PpkYp9>
- [10] F. Brauer, "Compartmental models in epidemiology," in *Mathematical epidemiology*. Springer, 2008, pp. 19-79.
- [11] S. Mwalili, M. Kimathi, V. Ojiambo, D. Gathungu, and R. Mbogo, "SEIR model for COVID-19 dynamics incorporating the environment and social distancing," *BMC Research Notes*, vol. 13, no. 1, pp. 1-5, 2020.
- [12] Danish SSI modelling group, "COVID-19 models used by the Danish SSI modelling group. github repository with documentation and full source code." [Online]. Available: <https://github.com/laecttu/C19DK>
- [13] The Danish Ministry of Health, "New automatic model for local shutdowns. (in Danish)," *Press release*, Mar. 2021. [Online]. Available: <https://sum.dk/nyheder/2021/marts/ny-automatisk-model-for-lokale-nedlukninger>
- [14] Q. Han, B. Zheng, M. Cristea, M. Agostini, J. J. Bélanger, B. Gützkow,

J. Kreienkamp, N. P. Leander, P. Collaboration *et al.*, "Trust in government regarding COVID-19 and its associations with preventive health behaviour and prosocial behaviour during the pandemic: a cross-sectional and longitudinal study," *Psychological medicine*, pp. 1-11, 2021.

[15] M. B. Petersen, "HOPE Project," *HOPE Project web site*, 2022. [Online]. Available: <https://hope-project.dk/#/about>

## AUTHOR BIOGRAPHY



**Jakob Stoustrup** (M'87-SM'99) has received an M.Sc. degree (EE, 1987) and a Ph.D. degree (applied mathematics, 1991), both from the Technical University of Denmark. From 1991-1996, Dr. Stoustrup held several positions in the Department of Mathematics, Technical University of Denmark. From

2006-2013, he acted as the head of research for Department of Electronic Systems, Aalborg University. From 2014-2016, Stoustrup was chief scientist at Pacific Northwest National Laboratory, USA, leading the Control of Complex Systems Initiative. From 1997-2013 and since 2016, Stoustrup has acted as a professor of Automation & Control, Aalborg University, Denmark. In 2017, Stoustrup was appointed as associate dean at the Technical Faculty of IT and Design, Aalborg University. Stoustrup's main contributions have been to robust control theory and to the theory of fault tolerant control systems. With coworkers, he has proposed a novel plug-and-play control framework and published approximately 300 peer-reviewed scientific papers. Apart from the theoretical work, he has been involved in applications in cooperation with 100+ industrial companies, including acting as CEO for two technological startup companies. Since 2020, Stoustrup has served as an advisor for the Danish Government in the Scientific Reference Group for COVID-19.