



**AALBORG UNIVERSITY**  
DENMARK

**Aalborg Universitet**

## **Behaviour of Soil Subjected to Dynamic Loads**

Bødker, L.

*Published in:*  
Dynamics of Structures 1993-1997

*Publication date:*  
1998

*Document Version*  
Publisher's PDF, also known as Version of record

[Link to publication from Aalborg University](#)

*Citation for published version (APA):*  
Bødker, L. (1998). Behaviour of Soil Subjected to Dynamic Loads. In *Dynamics of Structures 1993-1997: description of the projects in the research programme* (pp. 65-76). Dept. of Building Technology and Structural Engineering, Aalborg University.

### **General rights**

Copyright and moral rights for the publications made accessible in the public portal are retained by the authors and/or other copyright owners and it is a condition of accessing publications that users recognise and abide by the legal requirements associated with these rights.

- Users may download and print one copy of any publication from the public portal for the purpose of private study or research.
- You may not further distribute the material or use it for any profit-making activity or commercial gain
- You may freely distribute the URL identifying the publication in the public portal -

### **Take down policy**

If you believe that this document breaches copyright please contact us at [vbn@aub.aau.dk](mailto:vbn@aub.aau.dk) providing details, and we will remove access to the work immediately and investigate your claim.

# C1 Behaviour of Soil Subjected to Dynamic Loads

Lars Bødker

*Aalborg University, Aalborg, Denmark*

**SYNOPSIS:** Many geotechnical problems involve design of dynamically loaded foundations. The design criterion for dynamically loaded foundations is often described in terms of limiting values for the displacements. The displacements in the soil are normally very small when dealing with dynamically loaded foundations, and hence it is necessary to know the deformation properties for the soil at very low strain level. The main topic of the project is to increase the knowledge of the behaviour of Danish soils at small strain levels and to extend the laboratory facilities to deal with testing at small strains. The soil behaviour at very small strain levels is non-linear, and the most common testing technique for this situation is the resonant column technique. One of the aims of this project is to install, check, get familiar with and perform tests on different kinds of Danish soils in a new Drnevich Longitudinal-Torsional Resonant Column apparatus placed at the Soil Mechanics Laboratory at Aalborg University. Another, but quite new technique for small strain testing to determine the maximum shear modulus,  $G_{max}$ , is the bender element technique, and as part of the project this technique has also been introduced in the laboratory.

## 1 INTRODUCTION.

Very often geotechnical problems involve design of foundations to resist dynamic loading. Dynamic loading is characterised by the magnitude of the load fluctuating with time and the deformations of the soil consist of both recoverable and permanent displacements. Problems associated with dynamic loading are normally connected to the following design situations:

- machine foundations
- off shore structures exposed to wind- and wave loading
- on shore structures e.g. windmills
- structures exposed to traffic loading
- structures exposed to vibrations from earthquakes
- structures exposed to blasting

Foundations exposed to dynamic loading must normally fulfil both a static and a dynamic

design criterion. The static criterion normally requires both safety against failure and acceptable permanent displacements of the structure. The dynamic criterion also requires safety against failure, acceptable level of permanent displacements caused by consolidation from excess pore pressure generated by the dynamic loading, acceptable variable displacements of the foundation and safety against liquefaction. Very often the final design of foundations exposed to dynamic loading is determined by the established criteria to the variable deformations of the foundation.

Normally the design criterion for dynamically loaded foundations is described in terms of limiting values of accelerations, velocities or displacements. The limits are determined based on comfort requirements and the use of the structure. Figure 1 illustrates some general criteria depending on the actual use of the structure. The criteria presented in the figure are only intended as guidelines and they are

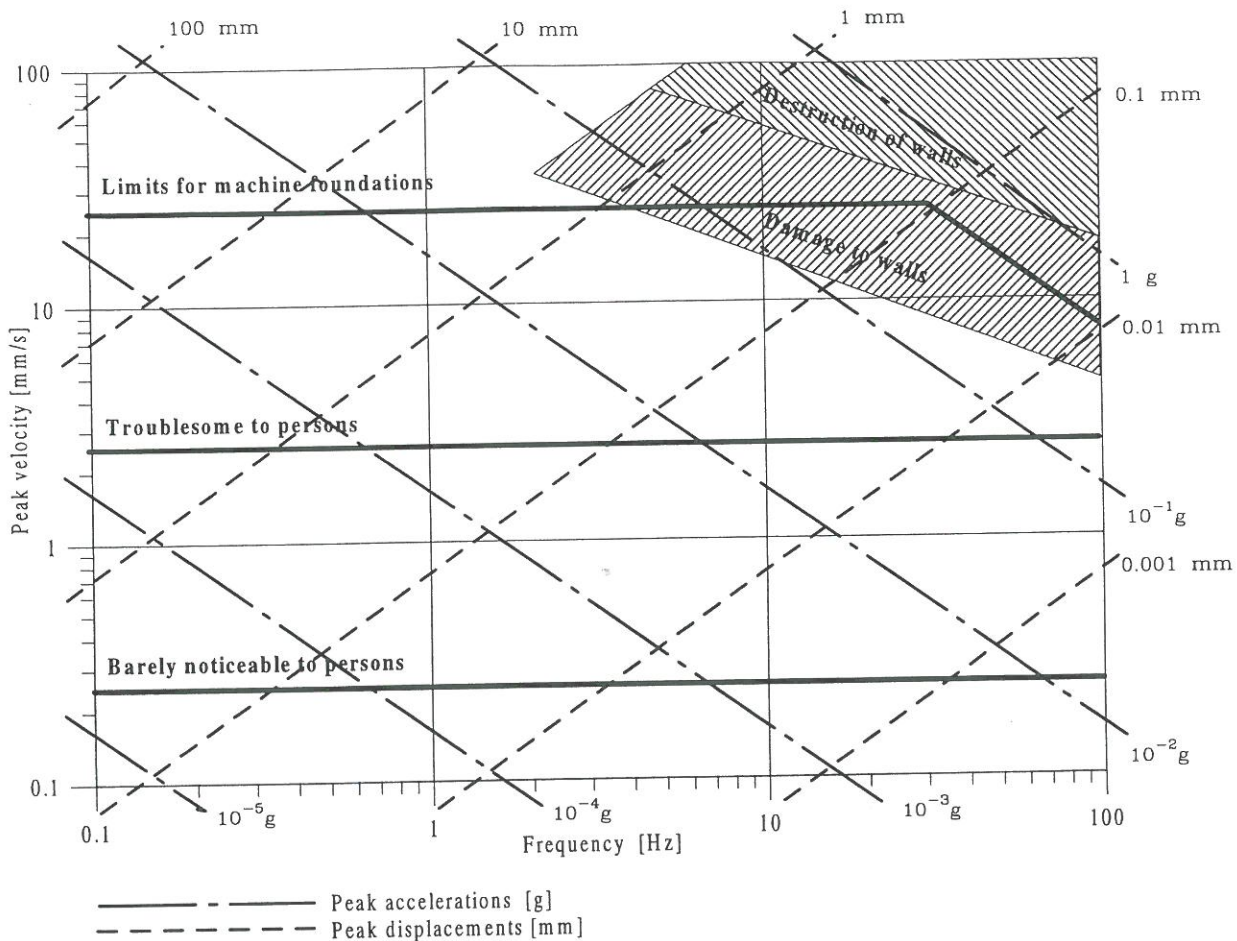

Fig. 1 Criteria for displacements, velocities and accelerations of foundations due to dynamic loading (after Richart, Hall & Wood, 1970). The criteria presented in the figure are only intended as guidelines.

based on motions of structures caused by blasting.

The criteria illustrated in Figure 1 are not unique as it may appear from the figure. First of all the limits are established due to tests with blasting. Therefore the persons and structures involved in the study are only exposed to a few cycles of vibrations. Secondly, the sound from the blasting may affect the way the persons perceive the vibrations. Thirdly, noise from the structures due to the vibrations will influence the limits for persons. Finally, distinction between secondary - such as windows and doors - and primary part of structures have to be made. Often seriously damage is observed on the secondary parts while the primary parts are intact.

From Figure 1 it appears that the sensitivity of persons often are the crucial factor when designing structures exposed to dynamic loading. Even at very low levels of vibration

persons notice the movements and feel it troublesome.

During the last decades extensive work has been put into developing new and more accurate models to predict the behaviour of dynamically loaded foundations. Depending on the design situation the models both involve wave propagation through the soil strata and half space theories, where foundations are assumed to rest on a half space, which in general will be modelled using spring and damping elements. Common to the models is that values for the stiffness and damping of the soil are required.

Because the behaviour of soil is very non-linear also for very small strain levels, the deformation parameters for the soil has to be determined at the stress and strain level for the actual design situation. The deformations due to the dynamic loading are normally very



small, and hence the behaviour of the soil has to be investigated at very small strain levels.

Behaviour of soils is a mixture of elastic and plastic behaviour. The elastic properties of the soil structure are primarily due to the behaviour of the individual grain and the contact between the grains, while the plastic behaviour is related to rearrangement of the grains or chemical/electrical bindings between the grains. At very low strain levels the soil exhibit elastic, albeit clearly non-linear, behaviour. Hence, it is essential to obtain reliable estimates of the elastic deformation parameters of soil, in particular at small strain levels for dynamically loaded foundations.

In Denmark no laboratory equipment for measuring the properties of soil at very low strain levels were present at the beginning of the work, and this fact initiated the content of the current project. Concurrently with development of new and more accurate models to describe the behaviour of soil the need for determination of the parameters at low strain levels for Danish soils also increases.

### *1.1 Content of project*

The current project deals with determination of the elastic properties, such as Young's modulus, the shear modulus, Poisson's ratio, and damping of both frictional soils and cohesive soils. These parameters typically form part of the analyses of foundations exposed to dynamic loading. The parameters can be determined experimentally by performing tests where the testing condition comply with the dynamic loading situation. The tests can be performed either in the field or in the laboratory. The present work is aimed at measuring and analysing the elastic deformation parameters determined only in the laboratory for different kinds of soils exhibited to dynamic loading. At small strain levels traditional laboratory tests, such as e.g. triaxial tests and simple shear tests, are not capable of describing the behaviour of soils for the mentioned conditions. Alternative tests have to be performed. The most common laboratory tests are resonant column tests and tests using piezoceramic bender elements. The resonant column testing technique was introduced in the 1940s and has been used in earnest since the

1950s, while the technique with bender elements is quite new in connection with soil testing.

In the current project the work has concentrated on introducing and developing new techniques for testing soil at low strain levels in the Soil Mechanics Laboratory at Aalborg University, AAU. At the beginning of the project a simple longitudinal resonant column apparatus was present at the laboratory, but the apparatus was limited to operate with stress states in the range of 0-100 kPa. In the project the facilities at the laboratory have been extended both with a longitudinal-torsional resonant column apparatus and introduction of bender elements in test set-ups.

The advantage of the resonant column device is that it is possible to control the strain level applied to the specimen during the dynamic testing. This facilitates the study of the non-linearity also at very low strain levels. In the tests using bender elements it is not possible to control the strain level, but instead the elements can be fitted into many conventional geotechnical testing equipment's.

By necessity, the main focus of the project had to be shifted from production terms to proof terms of the behaviour of the equipment and development and evaluation of interpretation techniques. To this end a number of tests on different kinds of clay and sand have been carried out in the new devices.

Besides the described content of the current project, some co-operative projects has been carried out during the research period.

Firstly, a co-operative project was carried out with the EU-founded LITASEIS project which is an international and interdisciplinary project. This project is dealing with field- and laboratory measurements of the dynamic properties of soils.

Secondly, as a result of a research period of 4 month at the Norwegian Geotechnical Institute in Oslo, Norway in the beginning of 1995, a co-operative project with the company was initiated and carried out concerning execution and interpretation of results from bender element tests.



## 2 RESONANT COLUMN EQUIPMENT

The most common testing technique to determine the elastic parameters for soil is the resonant column testing. Several different kinds of apparatus are available today. However, the general testing technique is to apply a sinusoidal force, and then adjust the frequency of the force until resonance in the soil column is established. For the different apparatuses the main difference is in the boundary conditions.

The most common configurations of the apparatus are sketched in Figure 2. Commonly, the configuration of the apparatus are based on the "fixed-free" model. The three models require slightly different driving equipment and methods of data interpretation. Model a) in Figure 2 is the true "fixed-free", while model b) is slightly changed by adding a rigid mass at the top. This configuration is used in the Drnevich type apparatus. The last model is known as the Hardin type. This apparatus was developed in order to allow application of anisotropic stress states to the soil specimen. The other two configurations only allow isotropic stress states.

The resonant column method consists of applying a sinusoidal axial force or torque to a cylindrical soil specimen, which can either be solid or hollow. The applied force or torque generate either compression or shear waves that propagate through the specimen and are reflected at the other end of the specimen. The frequency of the applied force/torque is adjusted until resonance is established, and the

moduli and damping ratio can be calculated. The main concern in interpretation of the measurements when doing resonant column test is, how the configuration of the apparatus is modelled and therefore how the performance of the apparatus fits the model. Especially, it is very important that the modelled and actual boundary conditions are in agreement. Mostly, a single degree of freedom model is supposed. Here one end of the specimen is supposed totally fixed, and at the other end a totally rigid mass is attached.

The apparatus that has been installed at the laboratory as part of the project is of the Drnevich type. The advantage of this type of device is, that it is capable of applying both longitudinal and torsional motions to the soil specimen and therefore allow both determination of Young's modulus, shear modulus and damping ratio at low strain levels. Applying both longitudinal and torsional motions also enables determination of Poisson's ratio, which is a key parameter in most numerical models.

The apparatus is more or less constructed as a conventional triaxial cell and accommodates cylindrical specimens. The diameter of the specimens can be either 35.7 or 71.1 mm and height to diameter ratio of 2. The top and bottom caps are rough platens mounted with large filter stones. The rough platens are necessary to ensure total contact between the soil and platen during rotational motions. The void space of the specimen may be filled with air, partially saturated or fully saturated with water. To enhance the degree of saturation application of back pressure has been enabled.

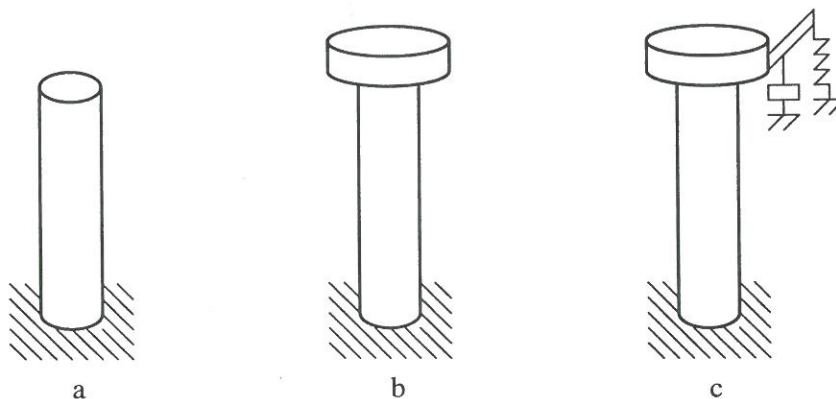
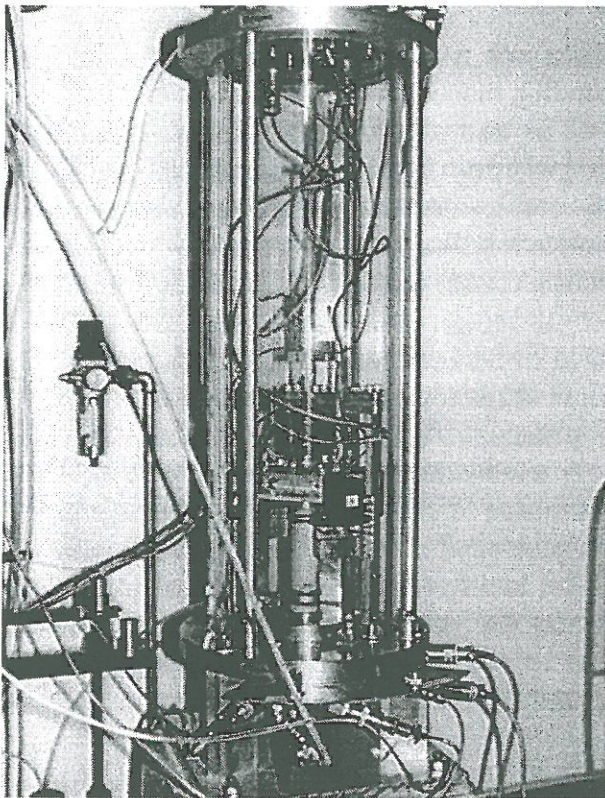

Fig. 2 Principle of the most common configuration of the resonant column apparatus.



The original device enabled drainage only as one-way or radial drainage. Construction of new top and bottom platens enables both one-way, two-way and/or radial drainage during the consolidation process. This reduces the consolidation time and the distribution of the pore pressure during consolidation is more uniform. The specimen is encapsulated in a latex membrane and surrounded by deaired water pressurised by means of regulated compressed air. The limit of the confining pressure for the apparatus is 700 kPa, and as mentioned before only isotropic stress states can be applied. The apparatus located at Aalborg University is shown in Figure 3.



*Fig. 3 The Drnevich longitudinal-torsional resonant column device located at the Soil Mechanics Laboratory at Aalborg University.*

The force or torque is applied at the top of the specimen, while the bottom is supposed to be totally fixed. The force or torque is applied by means of coils and magnets. A sinusoidal voltage is applied to the coils, which in reaction with the magnets makes the top move. The movements are measured by means of

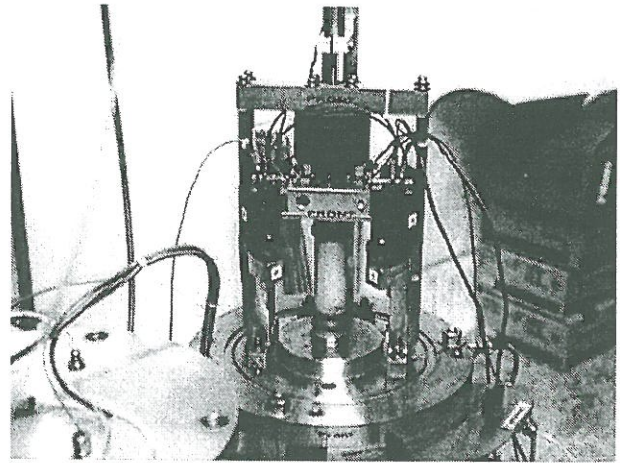

*Fig. 4 Detail of the loading system in resonant column device. Supporting frame for the magnets and coils and the top part is shown.*

accelerometers built into the top part. By adjusting the applied voltage the deformation level and therefore the strain can be adjusted. A detail of the system is shown in Figure 4.

The manufacturer of the apparatus prescribes how the apparatus must be installed to ensure proper performance when testing soil specimen. The apparatus is primarily made of steel and aluminium parts which are assembled with nuts. The cell is resting on three pedestals made of aluminium, which are bolted to an aluminium plate. The plate is connected to a block of concrete. The prescribed mass of the block is 140 kg. This should ensure fixity at the bottom of the specimen.

The installation of the apparatus was finished during spring 1996, and tests series on several different kinds of soils have been performed. The tested soils are both clay and sand.

As part of the project a four month research period at Norwegian Geotechnical Institute, NGI was included. The main purpose was to get familiar with the resonant column testing technique, and to perform some test in their resonant column device for duplication in the apparatus installed at AAU. By reproducing the tests, it is possible to see how the new apparatus behave compared with an old, well-tested apparatus. The apparatus at NGI is of the Hardin type, where only torsional motions are possible, and the results from the study



were presented in Bødker (1996). During the stay a lot of work was put into calibration and modelling of the apparatus, and five tests were performed. The soils used in the study were two kinds of clay, two kinds of sand and one silty soil. The soils were chosen to cover a large range of shear moduli.

A single degree fixed-free model, where the bottom of the soil specimen is supposed to be totally fixed, is used for interpretation of the measurements from the tests in the two apparatuses. The calculated shear moduli from the tests are shown in Figure 5. In the figure the corresponding results from the device located at AAU are plotted against the shear modulus calculated from the tests in the NGI device.

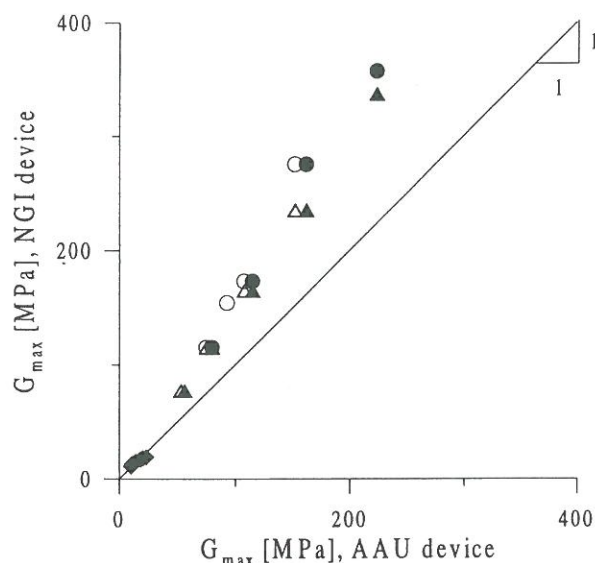

Fig. 5  $G_{max}$  determined in the NGI and the AAU resonant column device.

As seen from Figure 5 the results obtained in the AAU resonant column device deviate from the results from the NGI device. Therefore, the apparatus located at AAU has been thoroughly checked by placing accelerometers at different locations around the apparatus to observe the behaviour of the configuration when making a frequency sweep for both longitudinal and torsional motions. The response of the accelerometers showed, that the fixed boundary condition was not fulfilled. Therefore, the configuration of the apparatus has been changed. The mass of the concrete base has been increased and the stiffness of the bottom of the apparatus has been increased by

removing the aluminium pedestals and the aluminium plate and replacing some of the connections.

To check the new configuration a hollow specimen of plastic with well known material properties and dimensions has been produced. The vertical and torsional stiffness of the constructed specimen has been matched to the stiffness of a soil specimen with a shear modulus of 100 MPa and a Young's modulus of 300 MPa. A new frequency sweep was applied and the response showed that the new configuration behaves better. But still the condition of fixity is not totally fulfilled and several resonance frequencies are observed. By placing accelerometers at each corner of the top part resting on the specimen it is seen that the different frequencies measured matches resonance for one translation mode and two bending modes.

The test with the plastic specimen shows that when performing tests and interpreting the measurements from the resonant column device installed at AAU several things have to be improved. First of all three accelerometers for torsional motions and three for translation have to be installed in the top part. By using three accelerometers for each measurement, it is possible to see whether the response is due to a translation resonance mode or a bending resonance mode. Secondly, a new model has to be developed in which the boundary condition is not totally fixed, but reflects reality. In this model the stiffness and mass of the moving part of the bottom has to be determined and modelled. By the proposed improvements the testing method and model will be more complicated, but the amount and quality of information obtained from the tests will be increased.

### 3 BENDER ELEMENT EQUIPMENT

The behaviour of soil is non-linear, but at strain levels below approximately  $10^{-3}$  % the modulus,  $E$  or  $G$ , seems to be constant. Increasing the strain level above this limit the modulus decreases. The limiting or maximum value are normally termed  $E_{max}$  and  $G_{max}$ .



A very straightforward method to determine the modulus at very low strain levels is obtained by using wave propagation, either by compression or shear waves. While compression wave velocity is influenced by the degree of saturation of the void space, the shear wave velocity is almost unaffected. A new testing method based on the wave propagation theory is the bender element technique (Dyvik and Madshus, 1985). Using a set of piezoceramic bender elements as transmitter and receiver a shear wave is generated and propagated through a soil specimen.

The earliest work concerning transducers to generate and measure shear waves involved shear plates made of piezoelectric material such as quartz crystal or piezoelectric ceramic. A piezoelectric material is a material that can convert electric voltage into mechanical motion and vice versa.

The earliest type of transducer using shear plates is not suitable for measuring the shear wave velocity in soil specimens. The main problem with the transducer is the mismatch between the impedance of the element and the soil skeleton. The mechanical motion that is transferred from the element to the soil specimen is small because the element exhibits a small movement with a large force, while the soil exhibits a large movement with a small force (Shirley and Hampton, 1978).

One way to overcome the mismatch between the mechanical performance of the element and the soil is to use piezoceramic bender elements. Piezoceramic bender elements consist of two thin piezoceramic plates cemented rigidly together. The polarization of the ceramic material in the plates and the electrical connection results in elongation and shortening of the two plates respectively when a driving voltage is applied to the element (Shirley and Hampton, 1978; and Shirley, 1978). The performance of an single bimorph element is sketched in Figure 6.

The aim of the work performed by Shirley and Hampton (1978), was to make a system to determine the wave velocity in-situ. The scope was to make an apparatus which during coring could measure both compression and shear wave velocities. After development of the new piezoceramic bender element transducer,

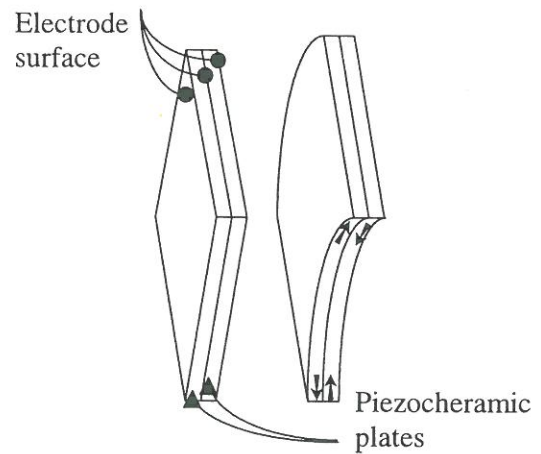

Fig. 6 Principle of single bimorph piezoceramic bender element. Relaxed element at left and excited element at right.

which was made of several bimorph elements Shirley and Hampton performed some tests on Kaolin clay in the laboratory using a transducer consisting of three bimorph elements fixed together. The results were very promising but because of the relatively high stiffness of the elements and therefore the small deflection the range of application is limited to high stiffness sediments. The noise sensitivity was also significant.

In Dyvik and Madshus (1985), a comprehensive work concerning construction of piezoceramic bender elements and implementation of these into conventional soil testing laboratory equipment is presented. They presented a bender element consisting of only a single bimorph element by which the stiffness of the bender element decreases significantly compared to the one used by Shirley and Hampton. Because of the small physical dimension of the bender elements it is easy to mount them in existing apparatuses. The advantages of incorporating the bender elements into existing laboratory equipment are that more information are obtained from standard laboratory tests. At the same time the need to run parallel resonant column tests to determine  $G_{max}$  is eliminated and  $G_{max}$  in itself can be a very useful guide during the consolidation process. These obvious advantages of using bender elements in existing laboratory equipment have increased the use considerably during the last decade.



Application of the bender element technique to determine the shear wave velocity and from this the shear modulus, is very simple if it is possible to generate and recognise the transmitted shear waves in the soil specimen.

The elements developed by Dyvik and Madshus seem to be suitable to generate and measure shear waves, and in 1985 they presented the comprehensive work carried out on specimens of clay, with shear modulus in the range of 10 - 100 MPa. In the paper they describe how to mount the elements in existing apparatuses and how to operate and interpret the results obtained from the elements. The equipment, they used, was the resonant column device fitted with bender elements. The advantage of using this apparatus is that the shear modulus is determined by two different and independent techniques but still on the same soil specimen. Hence, the calculated values for the modulus can be compared directly. The agreement between the moduli determined by the two methods was very good in the range of the testing.

Because of the promising results it was decided to introduce the technique at AAU as part of this project. The research in the project has been focused on two main subjects, namely comparison of shear moduli obtained by resonant column and bender element tests performed in the same device for a larger range of shear moduli and soil types, and

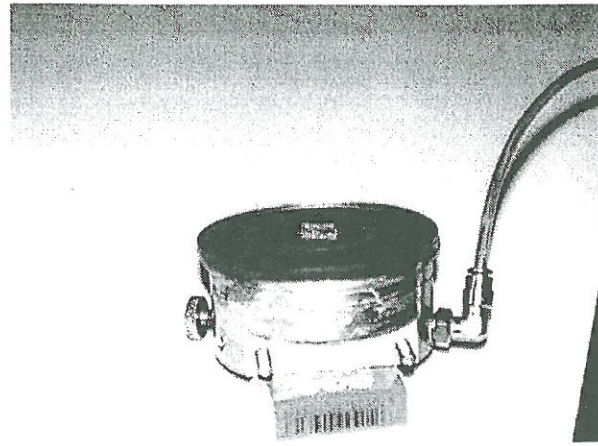

Fig. 7 Bottom cap used in triaxial test fitted with bender element.

development and performance of bender element tests in triaxial cells.

The first part has been carried out in the resonant column device located at NGI. The device is the Hardin type in which the platens have been fitted with bender elements. This enables concurrent resonant column and bender element tests on the same specimen.

The development of new equipment at the Soil Mechanics Laboratory at AAU has been concentrated on fitting the bender element technique to the triaxial test set-up. A bender element fitted into the bottom platen is shown in Figure 7 and the developed set-up is shown in Figure 8. Fitting the elements in the triaxial equipment makes the testing as flexible as the conventional triaxial test regarding the stress

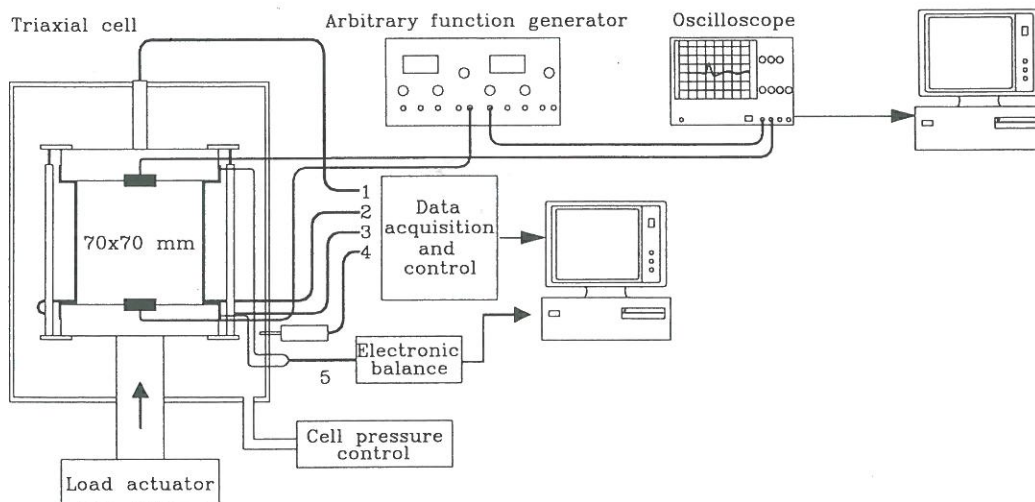

Fig. 8 Principle of test set-up for bender element tests in triaxial cell.



states. The elements are fitted into the same type of top and bottom platens as usually used in triaxial test, and both radial and vertical drainage is enabled and the platens are maintained as smooth. The dimensions of the element are  $H \times B \times D = 16 \times 12 \times 3$  mm.

The developed set-up shown in Figure 8 allows testing of both cohesive and frictional soils, and isotropic as well as anisotropic stress states may be applied to the soil specimen. The results from the tests such as stresses, deformations and wave propagation's are all stored on a computer for mathematical analyses of the response of the soil.

### 3.1 Testing technique.

In the method developed by Dyvik and Madshus an electric pulse is applied to one of the elements to generate the shear wave. By use of an oscilloscope also connected to the element placed at the other end of the specimen, the trace of the generated and received shear wave is measured. By knowing the exact time of generating and receiving the wave, the travel time is determined. Combining this with the travel length, defined as height of specimen less the protrusion length of the elements into the specimen, the shear wave velocity may be calculated. Assuming elastic behaviour the shear modulus is calculated as  $G = \rho v_s^2$ , where  $\rho$  is the density of the specimen, and  $v_s$  is the shear wave velocity.

The driving signal used by Dyvik and Madshus (1985), was a square wave. This

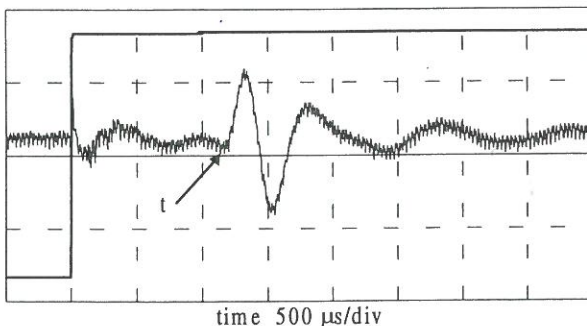

Fig. 9 Typical trace of square wave and receiver signal. The arrival time according to the definition by Dyvik and Madshus is marked with  $t$ . The result is from a test on a clay with a shear modulus in the range of 50 MPa.

choice is due to the fact that the time at which the wave is generated and sent is well-defined and unique. The arrival of the wave is then defined as the first clear inversion of the received signal. A typical example of a recorded trace is shown in Figure 9 where the arrival definition according to Dyvik and Madshus is marked. The disadvantage of the method using a square wave as driving signal is that the interpretation procedure is very difficult to automate because the elements is very sensitive to electrical noise which may interfere the signals, and hence make it difficult to define the first inversion.

A lot of workers have performed different kinds of tests using the bender elements. Dyvik and Madshus (1985), presented results from tests performed on five different kinds of clay, Langø (1991) presented results from tests on three different clays, Brignoli and Gotti (1992) performed tests on Kaolin clay, Suoto et al (1994) performed isotropically consolidated tests on road pavement materials such as sand and gravel, Viggiani and Atkinson (1995) performed a series of anisotropic consolidated tests on London clay and Bødker (1996) compared results from resonant column tests and bender elements for two kinds of sand, two kinds of clay and one silt.

The listed tests are all interpreted as described in Dyvik and Madshus (1985) using the single square wave as driving signal. The testing produce was developed in connection with tests on clay, and the range of shear moduli were quite limited. Extending the method to other materials and higher stiffnesses shows that very often it is hard to define the exact time of arrival of the shear wave (Bødker, 1996), see Figure 10.

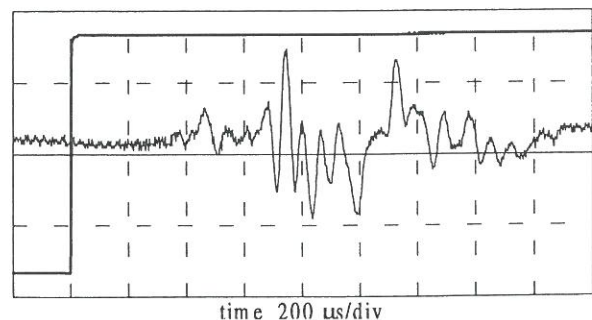

Fig. 10 Driving and receiving signal for test on sand. Definition of arrival time is not unique.



The stiffness determined by the bender element method in these tests is typically larger than the stiffness determined by the resonant column method when testing stiff materials. This can be due to the so-called near field effect, which is a small amplitude compression wave that is generated as the shear propagates through the soil. This compression wave will be observed a little time before the arrival of the shear wave, and therefore it will blur the definition of the correct arrival time of the shear wave.

The fact that problems occur when testing stiffer materials and the want of developing a procedure to automate the interpretation, has initiated an extensive study of the behaviour when using other driving signals than the square wave. The study has been a co-operative project with NGI, and it has concerned sine waves and the so-called Ricker wavelet. The mathematical description of the wavelet is given as  $g(t) = (1 - 2\pi^2 f^2 t^2) e^{-\pi^2 f^2 t^2}$ , where  $f$  is the frequency at peak in the power-spectrum and  $t$  is the time. The driving signals which have been used in the study are sketched in Figure 11.

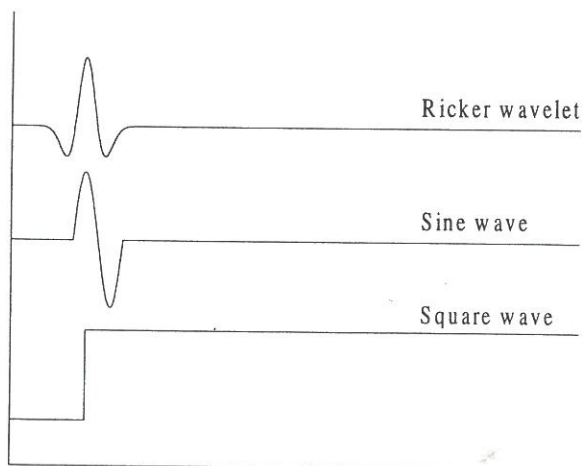

Fig. 11 Driving signal used in co-operation project with NGI concerning automation of bender element test.

The reason for using these waves is that it is possible to perform spectral analyses for both transmitted and received signals, and that the characteristic of the waves may minimise the effect of the near field compression wave. By using spectral analysis it is possible to mathematically calculate the travel time.

In the study of the effect of the type of driving signal applied to the transmitter both test on sand specimens and two different clays have been performed. The apparatus used is the NGI resonant column apparatus, which were installed at AAU for a period of two months. The set-up is in principle the same as shown for the triaxial cell in Figure 8. The time signals are all stored on the computer for further mathematical analysis.

The rationale for using the sine wave or Ricker wavelet is that it is possible to identify the transmitted signal in the received signal. The travel time is then calculated in two different ways. The travel time is determined by calculation of the cross-correlation between the driving and receiving signal, and by calculation of the slope of the frequency-phase diagram of the cross-spectrum.

To study the behaviour of the elements when excited, tests are performed where the elements are placed tip-to-tip. By placing the elements tip-to-tip the influence from the wave propagation through the soil skeleton is eliminated. The behaviour is studied both when the elements are surrounded by air and by different types of soil. When surrounding the elements by soil a thin slice of soil is placed between the elements in such a way that the tips just are in physical contact. The set-up with elements placed in air is shown in Figure 12.

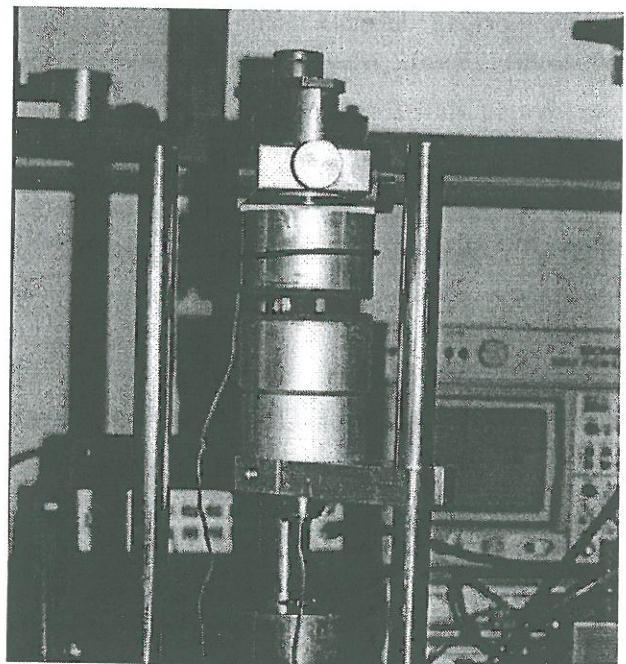

Fig. 12 Test set-up when testing elements tip-to-tip in air.



The response depending on the frequency of the driving signal of the elements is studied for the different types of waves. The frequency range tested for the sine wave and Ricker wavelet is 1 to 30 kHz.

The analysis shows, that when using a square wave as driving signal the deflection of the receiver placed in air is almost immediate and the peak of the deflection is delayed approximately 80  $\mu$ s. Calculation of the power-spectrum for the receiver shows that the recorded time signal consist of waves with frequencies of 5 and 50 kHz. Analysing the response when elements are placed in soil shows that the deflection is also almost immediate. When placed in sand the response looks like when placed in air, while the 5 kHz wave disappears when placed in clay.

Tests using the sine wave or Ricker wavelet show, that a time lag between the transmitter and receiver is introduced and the time lag changes depending on the frequency of the driving signal. Testing with elements placed in air and sand shows that for frequencies less than 3 kHz, i.e. less than the first natural frequency observed at 5 kHz, the response of the receiver is identical to the signal applied to the transmitter.

Increasing the frequency results in a lot of vibrations and the response is not at all looking like the driving signal which consists of only a single wave. In the mathematical analysis problems arise when receiving more than one single wave because the transmitted signal must be uniquely identified in the received signal.

Testing with elements placed in clay shows that the amplitude of the received signal is very small, but the response is not as "dynamic" as when placed in sand or air. Only when applying signals with the high frequencies more than one deflection is observed.

Generally, the tests with elements placed tip-to-tip show that the cross-correlation method give applicable results when using frequencies well below the limit at which the response changes and becomes dynamic and completely different from the signal applied to the element used as transmitter. But mostly, when using sine wave or Ricker wavelet a time

lag between transmitted and received signal is observed. This has to be taken into consideration when calculating the shear wave velocity in real tests.

The time lag for the tested materials with elements placed tip-to-tip is in the range of 0 to 30  $\mu$ s. The analysis of the time lag determined by calculation of the phase shows results with large scatter. The slope of the frequency-phase line is very sensitive to the range of frequencies at which the fit of the slope is carried out.

Both Ricker wavelet and sine wave signals generate vibrations with smaller amplitudes compared to the square wave. This fact is very important when using the elements in real specimens because of the material and geometric damping. The amplitude of the shear wave can disappear in electric noise if the amplitude is too small. This fact is observed in some of the tests performed on specimens with a height from 70 to 140 mm, where it is almost impossible to observe the shear wave at some stress levels. When increasing the frequency the amplitude increases but the tendency for generating near field waves also increases and often the signal becomes "dynamic", i.e. a lot of vibrations of the receiver is observed. If the response of the receiver does not fit the transmitted signal the mathematical analysis gives uncertain results.

Because of the described problems and uncertainties in the method using the cross-correlation to determine the travel time of the shear wave it is not at this moment possible to automate the testing technique. The response and behaviour seem to depend on several factors such as soil type and stress level. At this moment the traditional method using the square wave can not be rejected, and the problems with the near-field waves have to be studied more closely in the future.

## REFERENCES

- Souto, A., Hartikainen, J. & Özüdogru, K. (1994). Measurement of dynamic parameters of road pavement materials by the bender element and resonant column tests. *Geotechnique*, vol. 44, No. 3, pp. 519-526.



- Viggiani, G. & Atkinson, J. H. (1995). Stiffness of fine-grained soil at very small strains. *Geotechnique*, Vol. 45, No. 2, pp. 249-265.
- Bødker, L. (1996).  $G_{\max}$  determined by bender element at anisotropic stress states, *Nordiskt Geoteknikermøde, NGM-96*, Reykjavik, 26-28 June 1996, pp. 93 - 98.
- Richart, F. E., Hall, Jr. & Woods, R. D., (1970). *Vibrations of soil and foundations*. Prentice Hall, Inc., Englewood Cliffs, New Jersey, 1970.
- Brignoli, E. & Gotti, M. (1992). Misure di velocità di onde di taglio in laboratorio con l'impiego di trasduttori piezoelettrici. *Rivista Italiana di Geotecnica*, Vol. 1, pp. 5-16.
- Langø, H. V. (1991). *Cyclic shear modulus of natural intact clays*. Ph.D. Thesis, Norwegian Institute of Technology, Trondheim.
- Dyvik, R. & Madshus, C. (1985). Lab. measurements of  $G_{\max}$  using bender elements. *Advances in the art of testing under cyclic conditions, American Society of Civil Engineers*, pp. 186-192.
- Shirley, D. J. (1978). *An Improved Shear Wave Transducer*. Journal of the Acoustical Society of America, 63 (5) May, pp. 1643-1645.
- Shirley, D. J. & Hampton, L. D. (1978). *Shear-Wave measurements in Laboratory Sediments*. Journal of the Acoustical Society of America, 63 (2) Feb., pp. 607-613.

## PARTICIPANTS

Lars Bødker, Ph.D. student, Department of Civil Engineering, Aalborg University. Financed by the research program since 1.7.1994.

Lars Bo Ibsen, Assistant Professor, Department of Civil Engineering, Aalborg University.