



**AALBORG UNIVERSITY**  
DENMARK

**Aalborg Universitet**

## **Process Analytical Technologies for Anaerobic Digestion Systems**

*Robust Biomass Characterisation, Process Analytical Chemometrics, and Process Optimisation*

Holm-Nielsen, Jens Bo

*Publication date:*  
2008

*Document Version*  
Accepted author manuscript, peer reviewed version

[Link to publication from Aalborg University](#)

*Citation for published version (APA):*

Holm-Nielsen, J. B. (2008). *Process Analytical Technologies for Anaerobic Digestion Systems: Robust Biomass Characterisation, Process Analytical Chemometrics, and Process Optimisation*. Aalborg Universitet.

### **General rights**

Copyright and moral rights for the publications made accessible in the public portal are retained by the authors and/or other copyright owners and it is a condition of accessing publications that users recognise and abide by the legal requirements associated with these rights.

- Users may download and print one copy of any publication from the public portal for the purpose of private study or research.
- You may not further distribute the material or use it for any profit-making activity or commercial gain
- You may freely distribute the URL identifying the publication in the public portal -

### **Take down policy**

If you believe that this document breaches copyright please contact us at [vbn@aub.aau.dk](mailto:vbn@aub.aau.dk) providing details, and we will remove access to the work immediately and investigate your claim.

# Process Analytical Technologies for Anaerobic Digestion Systems

- Robust Biomass Characterisation, Process Analytical Chemometrics, and Process Optimisation

Jens Bo Holm-Nielsen

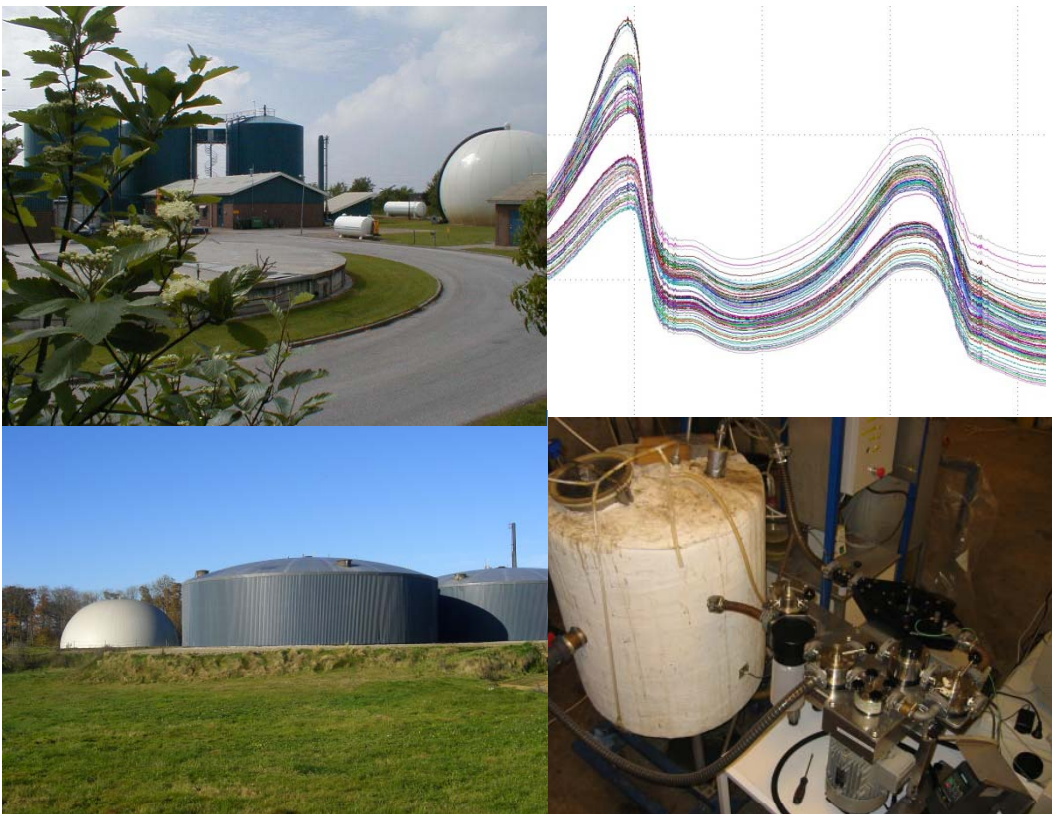



**Process Analytical Technologies for Anaerobic Digestion Systems:  
Robust Biomass Characterisation,  
Process Analytical Chemometrics and Process Optimisation**

**Ph.D. dissertation**

Jens Bo Holm-Nielsen  
ACABS-Research Group  
Esbjerg Institute of Technology  
Aalborg University

ISBN 978-87-7606-030-5

**Supervisor**

Professor Kim H. Esbensen  
Applied Chemometrics, Analytical Chemistry, Biotechnology,  
Bioenergy and Sampling Research Group (ACABS)  
Esbjerg Institute of Technology  
Aalborg University  
Niels Bohrs Vej 8, DK – 6700 Esbjerg

## **Preface**

This Ph.D. thesis is based on research conducted, during the five year period from 2002-2007, at the Research Group of Applied Chemometrics, Analytical Chemistry, Applied Biotechnology, Bioenergy and Sampling (ACABS), Esbjerg Institute of Technology, Aalborg University. This dissertation is submitted to complete the requirements for obtaining the Ph.D. degree.

The work has been organised as part of a five year contract with Aalborg University in a position as adjunkt/Ph.D. Fifty percent of this time was spent fulfilling the goals of the Ph.D. paradigm, the other half has been dedicated to teach and supervise student projects on bachelor and master level in the program Industrial Biotechnology and Bioenergy. In addition, for the entire period I have had the pleasure of contributing significantly to designing, funding and developing the bioenergy and green biotechnology laboratories at Esbjerg Institute of Technology (AAUE).

Simultaneously, I had the opportunity to continue the work part-time (20%) as head of the *Bioenergy Group*, since august 2007 *Centre for Bioenergy*, SDU, Esbjerg Campus. This work mainly concerned R&D projects of international dissemination and training programmes in the fields of Bioenergy as well as continuing our well-known Esbjerg-based European network of Bioenergy project collaboration.

The Ph.D. study has been an interesting journey of new experiences and new knowledge gained in many fields. Starting with the course in Philosophy of Science, which included totally new insights in natural science and technology, at the abstract level, and later courses in new skills of Chemo metrics and the Theory of Sampling. It has been a very enriching period of my life – but at a price: It has been an immensely intensive and time consuming five years, a price my family knows too well. When I am “too busy”, my wife is the one who knows best how to calm down a rolling stone.

## Acknowledgements

I want to express my most sincere gratitude to all colleagues, friends, and other contributors who have added value to the completion of this work, either by significant scientific collaboration, practical laboratory or technology work, or simply by being very supportive in one way or another:

- Professor Kim H. Esbensen, my supervisor. Since we met six years ago and I applied for the Ph.D. programme, a lot of fresh water has been running through the rivers where we, like salmons, are finding our spawning grounds. We have developed many new ideas in our creative discussion sessions amounting to a joint learning process. The results can be seen in significant contributions to the subject of ACABS' research as well as in the development of laboratories, new courses, or organising and conducting conferences or workshops at AAUE or internationally. Besides this, from Kim I have learned to appreciate other pleasuring facets of cultural life, like classical music and high quality wines.
- AAU and AAUE management. I am grateful that I was invited to have a scientific base in the ACABS research group for 5 years, and at the same time being allowed to continue my responsibility for my SDU Bioenergy-group. For the initial organisational coup I especially thank Institute head, Torben Rosenørn, vice dean Lars Døvling Andersen and Kim. The support from the institute and faculty has played an important role for me as I am about to reach my longstanding personal Ph.D goal.
- ACABS Research Group is a very busy and diversified group of internal and external university people and R&D resource persons from industries. At group meetings, courses, or social events there are always interesting discussions on the most diverse topics. Many research and project ideas have been discussed and developed in this scientific fermentor. Thank you all for a most enjoyable time: Lars Houmøller, Lars Petersen, Peter Paasch Mortensen, Carina Juel Lomborg, Casper K. Dahl, Hans Henrik Friis-Petersen, Jonas Sjøland, Marinda Swanepoel - as well as many guest researchers and international associates.
- Many students, staff and Ph.D students at AAUE have benefitted from the professional linguistic assistance from Ms. Anne Jodon Cole – I, and this Ph.D. work, no exception. I am very grateful for Anne's always forthright and constructive teachings and learnings.
- Laboratory staff and technicians, it has been of the highest importance to co-operate with you all - thank you very much. Reciprocally, I hope you have all learned during my research that manure and other such "smelly" interesting bioslurries can in fact be converted into something very useful for the society: electricity, heat, transportation fuel and organic fertiliser. A special thank you goes to Dorte Spangsmark, Linda B. Madsen, Suzanne Roy, Carsten Andreasen and Henry Enevoldsen.
- To all staff members at the institute: it has been some very good years of research and co-operation. I truly have enjoyed being one of the many individualists and/or R&D groups making up AAUE.
- Staff and managers at LinkoGas A.m.b.A. and Ribe Biogas Ltd. Aage Christensen, Aksel Buchholt and Lisbeth Ljungstrøm, Erik Husted and the regional farming community. A special thank you to Niels Tobiasen and Christian Nielsen, Farup by Ribe. These farmers and the biogas plants managers have always been very co-operative concerning research and demonstration projects, as well as suppliers of

feedstock of crop silages, straw, manure and digested manure. We will develop integrated sustainable farming together.

- Bioenergy Group at University of Southern Denmark, campus Esbjerg. Especially my colleagues for many years Teodorita Al Seadi and Kurt Hjort-Gregersen (KU-Life) and also the young complement of the scientific staff, Piotr Oleskowicz-Popiel and Michael Madsen as well as student assistants.
- To Professor Jens Born; my good friend at FHF-AAUE, thank you for many fruitful discussion concerning biorefinery developments in our minds and in the real world projects. *Economy of scale* is a very well-known international terminology – but for the future to introduce a much more important, dynamic and flexible task by the more unknown terminology *Economy of numbers* - we will go for it.
- External university and company partners in the international biogas and biorefinery communities. There are too many to mention all, but I would like to give a special thanks to:  
Henrik Møller, Department of Agricultural Engineering, Faculty of Agricultural Science, Aarhus University, Denmark  
Erik Steen Jensen, Mette Hedegaard Thomsen and colleagues at the Research Group of Bioenergy Systems at Risoe National Laboratories, Danish Technical University, Denmark  
Helga Andree and the ILV research group at University of Kiel, Germany  
Harald Lindorfer and research colleagues at IFA Tulln, University of Natural Resources and Life Science, Vienna, Austria.  
Company cooperation's, discovering many enthusiastic colleagues in; Danfoss, ASD, Q-Interline, NIRAS, and a lot more of Danish and Internationally contacts.
- A special thanks to Lars Schou, a very good industrial partner from Esbjerg. You have been doing a tremendously good job by introducing BioCore and creating building materials of lignocelluloses fibres. You and I have been co-working in the industrial biomass based businesses for quite some years. A special thank you for donating full scale equipment for making BioCore - biofibre boards as new building and insulation materials to our labs. You have made a difference in utilising straw and fibre based biomass in a completely new context, for building and housing purposes. A truly big inspiration for me, colleagues and students.
- To all international and Danish students at AAUE, enrolled or formerly enrolled in the study programmes and projects in Industrial Biotechnology and Bioenergy; it has been a pleasure to work with all of you. One group in particular looms high in my memory: AAUE experienced an exceptional cooperation with the first group of 14 students from Poznan University of Technology, Poland, who obtained their M.Sc. degrees from AAUE during the first part of my thesis work. They were closely involved in trials and tests of new methods of anaerobic digestion and pre-treatment methods of biomasses.

My gratitude is also warmly sent to my family - my wife Lis, and our young folks Sara, Thomas and Anne. Don't forget to enjoy life, even when you are met with time consuming challenges, as I was met through this thesis work. There are many interesting doors to be opened and paradigm changes to work for, like the challenges of reducing the impacts of global warming. You have given me strong support and encouragement by all means.

Esbjerg/Ribe, Spring 2008  
Jens Bo Holm-Nielsen

## 1 Abstract

This Ph.D. study has developed new Process Analytical Technology (PAT) approaches aimed at on-line monitoring, optimisation, and control of anaerobic digestion processes. The feedstocks used for anaerobic digestion are highly heterogeneous by nature, since they originate from diverse organic waste streams in agriculture and society, the dominating major biomass resources being animal manure. The prime focus areas throughout the studies is documented in the four thesis papers: Containing how to sample such feedstocks correctly with respect to preserving *representativity*, and how to monitor and control the fermentation processes on-line by non-invasive technologies

The anaerobic digestion process is highly complex, and at present its individual steps are not known in sufficient detail; although, its overall practical success is witnessed by many operative bioenergy plants in the world today. The potential for optimal yields and minimum side effects is not at all fully optimised. However, important biochemical intermediates in the process can be monitored on-line as shown by the present research and by the R&D steps set into operation during this thesis. Controlling the biogas process more fully and effectively will enable it to become one of the major renewable energy players from the fermentation process industries, and it will assist in boosting the biogas sector to become a strong greenhouse gas reduction tool on a regional scale worldwide. The introductory part of this thesis outlines a broad perspective for this setting, necessary to understand the potential of more modern and effective monitoring and control possibilities of the biogas process.

Several attempts to introduce advanced on-line process control in the anaerobic digestion process are presented. This thesis summarises a series of studies, the objective of which is design, test, document, and implement Process Analytical Technologies (PAT), at critical R&D scales, from the laboratory via the pilot-plant to full-scale operation. The focus in **Paper 1** is to make the Theory of Sampling (TOS) operational in fermentation processes by introducing a one-dimensional recurrent loop in a vertical upward-stream configuration, to furnish a fully TOS-representative sampling point. **Papers 2** and **3** document at-line and on-line studies of Near Infrared spectroscopy as a tool for real-time monitoring and process control of the biogas process at the laboratory development scale. In these studies, increasing correct sampling, process analytical chemistry, physical parameter analysis and multivariate data analysis have been the focus areas. Supplementary studies at meso-scale 150 l fermenters have been conducted and especially the final **Paper 4** documents that the introduction of PAT tools will be possible for on-line monitoring and control. At 2400 m<sup>3</sup> full-scale fermenters, PAT applications were introduced and tested for advanced process monitoring and control systems in anaerobic digestion processes.

1. Holm-Nielsen J.B., Dahl C.K., Esbensen K.H.: Representative sampling for process analytical characterisation of heterogeneous bioslurry systems – a reference study of sampling issues in PAT. Chemo metrics and intelligent laboratory systems, vol. 83, pp. 114 - 126 (2006). DOI: 10.1016/j.chemolab.2006.02.002
2. Holm-Nielsen J.B., Andree H., Lindorfer H., Esbensen K.H.: Transflexive embedded near infrared monitoring of key process intermediates in anaerobic digestion/biogas production. Journal of Near Infrared Spectroscopy, vol. 15, pp. 123-135 (2007) ISSN 0967-0335. DOI: 10.1255/jnirs.719



3. Holm-Nielsen J.B., Lomborg C.J., Oleskowicz-Popiel P, Esbensen K.H.: On-line Near Infrared monitoring of glycerol-boosted anaerobic digestion processes – evaluation of Process Analytical Technologies. *Biotechnology and Bioengineering*, vol. 99, no.2, pp. 302 – 313, (2008). DOI: 10.1002/bit.21571

4. Holm-Nielsen J.B., Larsen K.J., Møller H., Møller H.B., Njoku S., Boland L., Madsen M. and Esbensen K.H.: Process Analytical Technology - monitoring of biogas processes at Meso- and Full-Scale Biogas Plants. *Submitted May-2008 to Journal of Biotechnology and Bioengineering, Wiley Periodicals, Inc.*

## 2 Synopsis

Målet med dette Ph.d-studium var at udvikle procesanalytiske værktøjer egnet til on-line overvågning, optimering og styring af den anaerobe omsætningsproces (biogasprocessen). Råvarerne, der indgår i produktion af biogas, er yderst heterogene af natur eftersom de udspringer af mangfoldige organiske affaldsstrømme i samfundet; én af de større biomasseressourcer er husdyrgødning. Fokus i afhandlingen og de bagvedliggende videnskabelige artikler har været rettet mod, hvordan man korrekt udtager prøver af sådanne heterogene råvarer med henblik på at bevare repræsentativiteten og på, hvorledes fermenteringsprocessen kan styres online anvendende non-invasive måleteknikker.

Den anaerobe omsætningsproces er meget kompleks og p.t. er dens individuelle procestrin ikke beskrevet i detalje. Vigtige biokemiske nedbrydningsprodukter kan overvåges online, som dokumenteret i artiklerne og i løbet af forskningsarbejdet. Effektiv styring af biogasprocessen vil bane vej for, at den kan blive én af de førende fermenteringsindustrier og samtidig øge biogassektorens rolle som effektivt værktøj til at reducere emissionen af drivhusgasser.

Der er blevet gjort adskillige forsøg på at introducere avanceret online processtyring i den anaerobe omsætningsproces. Nærværende afhandling opsummerer en række videnskabelige studier, hvor procesanalytisk teknologi (*Process Analytical Technology*, PAT) er blevet undersøgt, testet og implementeret på forskellige skalaniveauer. Fokus i **artikel 1** var at gøre Teorien Om Sampling (*Theory Of Sampling*, TOS) operationel i forhold til fermenteringsprocesser gennem introduktion af et 1-dimensionalt pumpeloop (opadstrømmende) indeholdende TOS-korrekte prøvetagningspunkter. **Artikel 2** og **3** dokumenterer at-line og on-line studier anvendende nærinfrarød spektroskopi som et værktøj til overvågning af biogasprocesser i realtid i laboratorieskala. I disse studier var prøvetagning, procesanalytisk kemi og multivariat dataanalyse i fokus. Supplerende studier og **artikel 4** dokumenterer, at introduktion af PAT-værktøjer til avanceret on-line processtyring af anaerobe omsætningsprocesser er muligt i fuldskala.

1. Holm-Nielsen J.B., Dahl C.K., Esbensen K.H.: Representative sampling for process analytical characterisation of heterogeneous bioslurry systems – a reference study of sampling issues in PAT. Elsevier, Chemo metrics and intelligent laboratory systems, vol. 83, pp. 114 - 126 (2006). DOI: 10.1016/j.chemolab.2006.02.002
2. Holm-Nielsen J.B., Andree H., Lindorfer H., Esbensen K.H.: Transflexive embedded near infrared monitoring of key process intermediates in anaerobic digestion/biogas production. Journal of Near Infrared Spectroscopy, vol. 15, pp. 123-135 (2007) ISSN 0967-0335. DOI: 10.1255/jnirs.719
3. Holm-Nielsen J.B., Lomborg C.J., Oleskowicz-Popiel P., Esbensen K.H.: On-line Near Infrared monitoring of glycerol-boosted anaerobic digestion processes – evaluation of Process Analytical Technologies. Biotechnology and Bioengineering, vol. 99, no.2, pp. 302 – 313, (2008), Wiley Periodicals inc. – InterScience. DOI: 10.1002/bit.21571
4. Holm-Nielsen J.B., Larsen K.J., Møller H., Møller H.B., Njoku S., Boland L., Madsen M. and Esbensen K.H.: Process Analytical Technology - monitoring of biogas processes at Meso- and Full-Scale Biogas Plants. Submitted May-2008 to Journal of Biotechnology and Bioengineering, Wiley Periodicals, Inc.



### 3 List of Contents

Preface.....	2
Acknowledgements .....	3
1 Abstract.....	5
2 Synopsis.....	7
3 List of contents .....	8
4 Process Analytical Technologies applied on Anaerobic Digestion Systems.....	10
4.1 A change of paradigm in terms of energy sources and of land use in this and the coming decades .....	12
4.2 Biomass resources .....	13
4.3 Biorefining.....	14
4.4 Anaerobic digestion – the main biogas production process .....	15
4.5 Thesis studies - biogas process monitoring: introduction of PAT and new concepts .....	16
4.6 References .....	17
5 Biomass Resource Feedstocks.....	20
5.1 Biomass Resources – Manure and Energy Crop Potentials for Bioenergy in EU-27.....	20
6 Biogas – AD in general .....	38
6.1 Manure-based biogas systems – Danish experience.....	38
7 Management of Anaerobic Digestion processes by Process Analytical Technologies .....	54
7.1 Anaerobic Digestion process control.....	54
7.1.1 Spectroscopy seems to hold the key to a practical and reliable on-line measurement and control of intermediates i.e. VFAs in the complex anaerobic digestion process.....	58
7.2 Process Analytical Technologies – including NIR sensor technology as a PAT tool for on-line anaerobic digestion monitoring and process control.....	59
7.3 Sampling issues in the context of AD process control .....	63
7.4 Multivariate data analysis – Chemometrics as the final tool for process AD control .....	68
8 Papers prelude, thesis perspectivation and conclusion .....	80
8.1 Paper 1 – How to make the Theory Of Sampling operational in fermentation processes. Introduction of the recurrent process loop for sampling and monitoring of the anaerobic digestion process .....	80
8.2 Paper 2 – Process monitoring of key process intermediates in anaerobic digestion. First step towards on-line monitoring of biogas production with NIR as a PAT tool.....	81
8.3 Paper 3 - Anaerobic digestion process control by direct on-line process analytical technology testing during glycerol spiking trials in laboratory fermentors.....	82
8.4 Process Analytical Technology: - Monitoring of Biogas Processes at Meso- and Full-Scale Biogas Plants .....	82
8.5 Thesis perspectives - Biomass, bioenergy, biorefineries.....	83
8.6 Thesis Conclusions.....	86
9 Full publication list.....	90
10 Main papers – papers 1-4	



## 4 Process Analytical Technologies applied on Anaerobic Digestion Systems

### Introduction – thesis pathways and perspectives

The reason for the studies presented in this thesis can be divided into four parts of an evolutionary pathway, which furnishes an overview of the subject-matter context (Fig. 4.1). The first part, the biomass resource base, concerns *where* and *how* to generate biomass in the biosphere in a sustainable and environmentally safe manner. Studies and papers presented at various conferences have been *integrated* into this introductory part of the thesis.

The second section goes deeper into one of the most important bioconversion processes, the anaerobic digestion (AD) process. The objective of AD is to produce biogas based on biological degradation of complex and heterogeneous biological feedstocks. Earlier these raw materials were usually, yet incorrectly, considered as biological waste. This chapter also addresses how a managing system - process control - can be integrated in the AD process following effective on-line gas production monitoring. AD processes have, until recent years, been regarded as a *black box* process; too difficult to monitor effectively and too difficult to control on-line.

The third part aims at even deeper layers of insight of the AD process by introducing and evaluating the possibilities of utilising Process Analytical Technologies (PAT) tools starting with off-line, at-line, through in-line to *real-time* on-line full-scale studies in the microbial and biochemical conversion process. This is made possible by utilising a powerful sensor system, Near InfraRed (NIR) spectroscopy, in combination with chemo metric data analysis - multivariate calibration, including representative sampling and chemical analysis in the laboratory. These tools are introduced to develop operational concepts and models for future PAT instrumentation packages for on-line process control of anaerobic digestion. Other fermentation processes in the biofuel sectors can also benefit from the results generated in this thesis. Importantly results have a strong carry over potential to food, feed, and pharmaceutical sectors.

The fourth and final part is dedicated to the perspectives of R&D on advanced process control, in the form of non-invasive PAT tools to control conversion processes in general based on highly complex biological substrates, e.g. bio-slurries. The perspectives for integrating processes of producing both gaseous and liquid biofuels through fermentation are gaining increased interest through the *emerging concept of the green biorefinery*. The period 2000-2020, can in my mind, be expected to be a transition period, going from the fossil fuel energy dependency in the last century through a paradigm shift towards renewable energy based economies where biomass, wind, solar, and other renewable energy sources in conjunction with extensive energy savings and increased energy efficiencies will be the main focus areas.

The most recent prospects of *disruptive technologies*, such as producing biofuels directly from biogenic resources through the action of genetically modified organisms (GMO), must be mentioned though it is still a controversial pathway, specifically in Europe. Societal acceptance or not, regarding GMO, is still an open question to be discussed. If or when this pathway is accepted like in crop breeding programs, in micro-organisms like algae or pharmaceutical production. It could also open up for opportunities for completely new

possibilities for actually *creating* an optimal micro-organism flora and/or fauna for biorefining, including AD fermenter applications under complete controlled conditions.

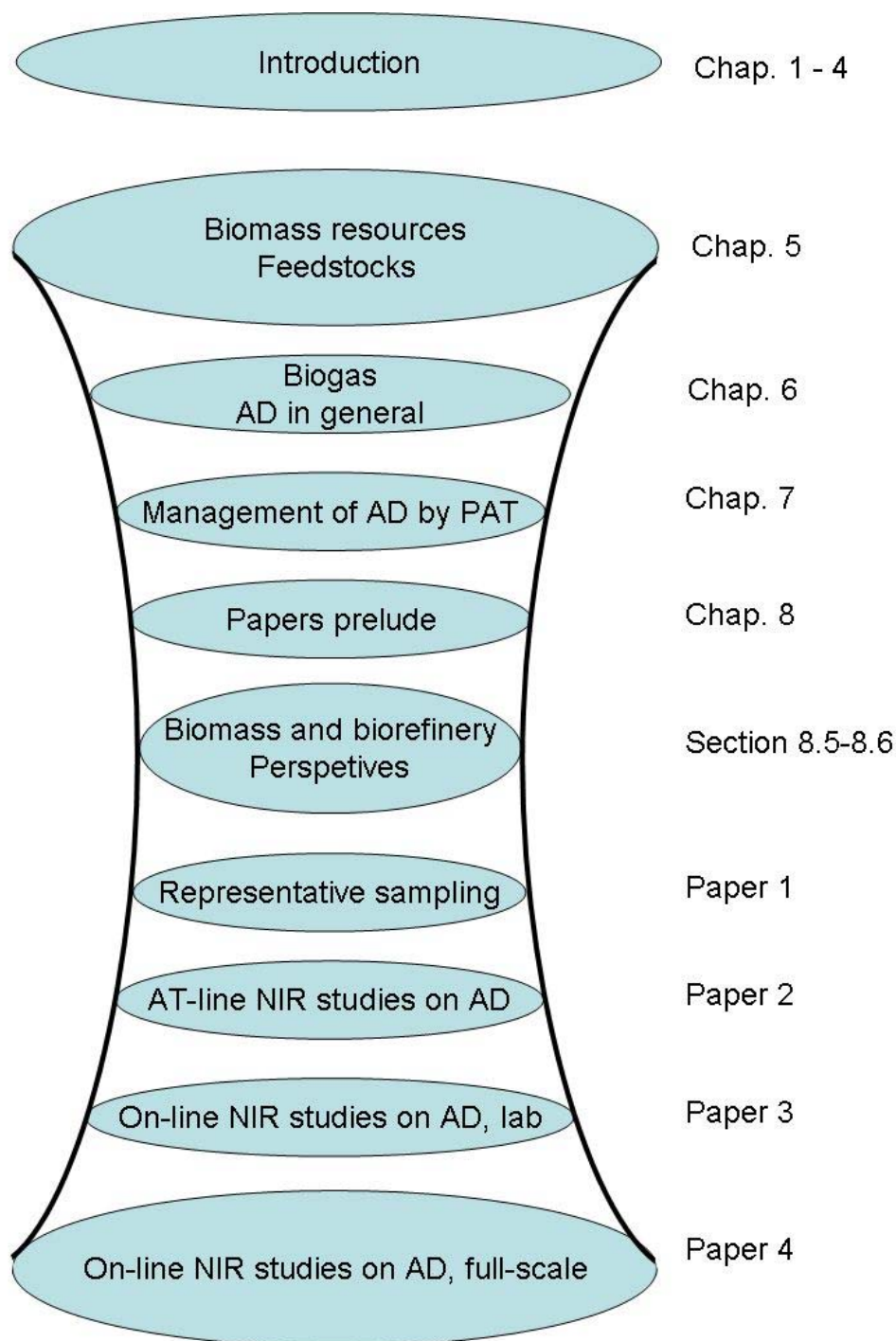

**Fig. 4.1: Thesis pathways: bio-mass resource base, main conversion technology for biogas production, process monitoring and control of anaerobic digestion (AD) by Process Analytical Technologies (PAT), biomass and biorefining contexts and perspectives. Focus of thesis papers starts with sampling issues, followed by at-line measurements of the AD process, ending with the on-line full scale biogas plant studies.**

#### **4.1 A change of paradigm in terms of energy sources and of land use in this and the coming decades**

Over the last 5-10 years, most recently in 2007, the Intergovernmental Panel of Climate Change (IPCC), accompanied by many societal, environmental, and political groups and movements, and a growing number of national governments have acknowledged the existence of an environmental and climate *crisis*; The main impact of which is caused by consumption of fossil fuels. Several adverse, abnormal weather conditions like flooding, droughts, forest fires, hurricanes, and other damaging phenomena are occurring more frequently and with steadily increasing numbers every decade for the last two generations. Increased global average temperature over the continents and in the oceans, have been reported and documented in the series of IPCC reports, latest in 2007 (IPCC, 2007).

The increase of emissions of greenhouse gasses, carbon dioxide, methane, nitrous compounds, and CFC gasses are now generally acknowledged as the main drivers for the exponentially increasing temperature development. Energy production based on fossil fuels is the direct cause behind the accumulative growth of the most “effective” atmospheric greenhouse gasses and their impact on global warming and the shifting climate patterns. Energy security, sustainability concerns, and global warming have finally become global issues highly ranked on the political agenda. At present, fossil fuel energy resources are meeting 79% of the world’s energy demand; seven percent is covered by nuclear power, while renewable energy is responsible for a modest 14% (European Commission, 2005).

Diversity in the energy supply portfolio is necessary in order to reduce the dependency on any single energy source, (Logan, 2006), and from this better securing the energy supply. Time will very soon be running out for conventional fossil fuels; with the most negative environmental impacts directly related to consumption of coal, crude oil, and natural gas. Naturally, all energy products of interest must live up to a certain minimum standard with regard to environmental and health impacts. The energy sources and their conversion chains must be sustainable, renewable, and zero-to-low in carbon dioxide and other greenhouse gas emissions.

New studies estimate that 75% of the global energy demands can be covered by the utilization of a broad variety of renewable energy sources with increasing speed towards the end of the time period 2030-2050. These studies proposes a true change in paradigm, which shifts the societies from being dependent on fossil fuels to become economies based on renewable energy sources (Holm-Nielsen et al, 2007, Smeets et al. 2007, UN 2007). This vision, although not realistic without a truly global UN-political commitment through agreements at Bali and next Copenhagen summits 2007-2009, is never-the-less critical as a necessary goal. This goal constitutes a positive, constructive, and realistic alternative of today’s energy consumption mainly based on fossil fuels. We must also be aware of being ready to look straight in our grandchildren eyes at the end of the day, explaining that we have many lessons to learn throughout each lifetime, and the last century mainly based on fossil fuels was a risky period for the global environment and climate.

A number of pollution-free, sustainable, and renewable energy sources exist. Solar power in terms of thermal and photovoltaic energy systems, and hydropower both conventional and more recent sources include, wave generator research and developments, geothermal energy, wind power, and last but not least energy derived from biomass. All of these sources carry great potentials to reverse the negative effects originating from utilization of fossil fuels on global warming and environmental pressure on aquatic, terrestrial and atmospheric pollutants.



In the long term, the global energy supply can only be secured through an intelligent integration of a variety of renewable energy sources in combination with energy saving strategies and energy efficiencies integrated in the systems. None of the energy source can be a stand alone source; a mixture of at least three renewable energy sources will give a good platform for a sustainable and secure local, regional, national, and finally global energy supply.

## **4.2 Biomass resources**

Biomass is by definition a sustainable, renewable energy source. Biomass is formed during photosynthesis that captures carbon dioxide from the atmosphere, water and nutrients from plant root zone, and solar radiation. Carbon, hydrogen, and oxygen are the main elements stored in plant cell biomass. The amount of carbon dioxide released subsequently upon combustion or conversion of the biomass *almost* equals the amount that was initially stored during photosynthesis. It will never be completely carbon dioxide neutral to utilise biomass in energy conversion, because the energy consumed during the processing also has to be taken into account. But when this process energy is also based on renewable energy sources, a positive carbon dioxide balance can ultimately be obtained. In the future this means that we should set up screening and selection among bioconversion processes to identify the most carbon dioxide efficient alternatives, optimised in terms of maximum reduction of the CO<sub>2</sub> loading to the atmosphere.

The production of biomass-derived energy direct from crops - energy crops, cultivated on farmland is another paradigm change that has emerged recently in many countries around the world. In Germany, 13% of the rotational farmland was dedicated to energy production in 2006. Studies indicate that there will be sufficient commercial farmland and forestry areas available for all these purposes, with restrictions and evolved political framework to monitor and manage the land use utilization. (UN, 2007, Holm-Nielsen, 2007, Smitts, 2006). Biomass for energy production has to find a sustainable balance with land use for primary food and feed production, mainly from rotational or commercial farmland. Carbon foot prints have to be at the best obtainable level, which means not all biofuel production is acceptable, like palm-oil production, originating from rain forest areas, will have no future internationally speaking (Malhi, 2008).

From natural resource areas and environmental sensitive areas, which exist in all countries all over the world, restrictions and codex rules are highly needed for the utilization of biomass as a possibility for regulation or restoring the biodiversity. As delineated above, biomass has to be seen as one important component in a sustainable holistic approach together with other renewable energy sources. One advantage for biomass based energy systems is the possibility of carbon capturing and sequestration in fixed molecular structures as carbon storage. The biogenic fuels can be stored over time, securing and regulating the demand of energy at a given time. This approach creates flexibility, stability, and security in the global energy supply chain, and has a stronger management position compared to direct solar or wind source.

### 4.3 Biorefining

Biomass can be utilised for industrial and energy production in several ways. One key approach, which has gained increased attention recently, is integrated processing in *biorefineries*. Analogous to petrochemical refineries producing wide ranges of products from crude oil, the same principles and innovative biotechnology processes can be applied to convert plant molecular structures to a variety of products needed in society. A biorefinery has many advantages over petrochemical refineries and is rapidly gaining increasing interest (Kamm, 2006, Lasure, 2007).

#### The Green Biorefinery concept

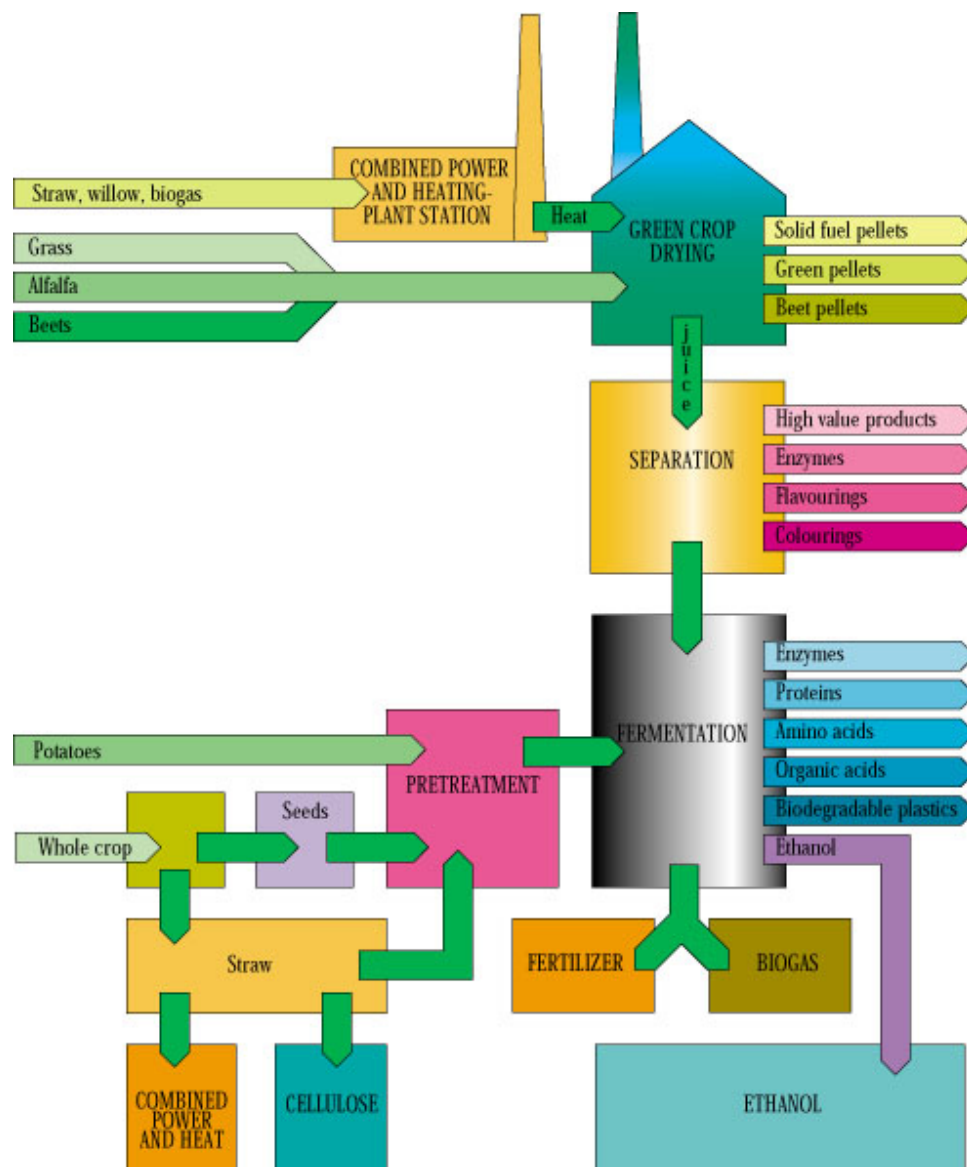

Fig. 4.2. An example of a green biorefinery flow diagram showing crops as input resources, several biotechnological process steps and the final end product portfolio. This example concerns production of bioethanol in the green biorefinery (Kiel et al., 1994).

A *biorefinery* can be defined as a processing facility that converts biomass in a highly integrated mode into an assortment of valuable products like food, feed, fuels, fibres for building and insulation purposes, and last but not least organic fertilisers. An important keyword here is *process integration*. A biorefinery has the capability of utilising multiple biological feedstock depending on their availability and market conditions. Furthermore, organic by-products generated in one part of the biorefinery often serve as substrates in another. This is apparent when integrating production of liquid biofuels with biogas. The anaerobically digested biogas substrate can be separated into a liquid, as highly valuable organic fertiliser, and a solid ligno-cellulose rich fibre fraction suitable for further enzymatic hydrolysis and subsequent bioethanol fermentation or other purposes. The term, *waste products*, is more or less non-existent in the context of biorefining. In this new biotechnological approach, fundamental advantages exist e.g. low process temperature, low energy consumption, and high product specificity being some of the most important factors (Thomsen, 2005)

There is a very broad diversity in the product portfolio from biorefineries, as it can be seen in Fig. 4.2. The main process in a biorefinery involves dedicated use of *micro-organisms*: bacteria, yeast, and fungi. Since the conversion of feedstock into products is performed by living organisms, the processes are normally carried out at relatively low temperatures. Still, the overall energy efficiency of a biorefinery has to be optimised to ensure the economical and environmental feasibility. Applied synergistic and integrated processes can solve many practical problems, provided that the solutions are implemented already in the planning phase of the biorefinery concepts (Kiel, 1994, Born, 2005, Holm-Nielsen, 2007).

#### **4.4 Anaerobic digestion – the main biogas production process**

By definition *anaerobic digestion* is a mixture of complex consortia of micro-organisms by which four main steps of conversion processes simultaneously take place. During these stages organic substrates are degraded into the end product biogas. Biogas is a mixture composed by major components: approximately 2/3 methane gas - CH<sub>4</sub> and 1/3 carbon dioxide gas - CO<sub>2</sub>. Hydrogen sulphide, H<sub>2</sub>S, ammoniac NH<sub>3</sub>, and other trace gasses are present at the level of parts per million (ppm). Each consortium of micro-organisms thrives optimally at a given set of biological, chemical and physical conditions and with various conversion rates. The various steps of anaerobic digestion are highly complex, but are taking place simultaneously when handled with good management at the biogas plants.

The anaerobic degradation process can in general be divided into four major phases as depicted in Fig. 4.3; hydrolysis – acidogenesis – acetogenesis – methanogenesis. The methanogenesis constitutes the final and most sensitive step in the multifaceted processes. The operating conditions can have severe influence on all steps in the process, but mainly on the slowest steps like the final formation of methane. Examples of parameters that affect the various steps in the anaerobic digestion processes to various degrees are the composition of the feedstock, pre-treatment, feeding rate, and temperature control (Mata-Álvarez, 2000, Angelidaki, 2002).

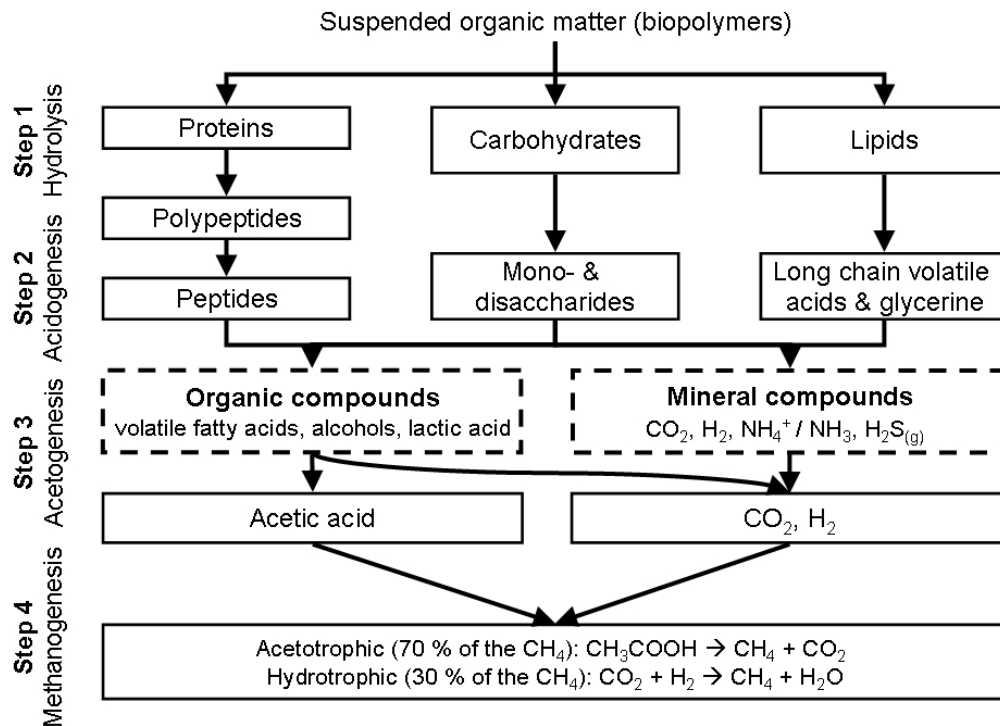

**Fig. 4.3:** The four principal process steps in the general anaerobic digestion – biogas production process. The dashed boxes indicate important intermediate compounds (Holm-Nielsen et al 2008, in. prep).

The centralised Danish biogas plant concept is based on *co-digestion processes*. Digestion of single substrates, such as a single source pig or cow manure, produces a low biogas yield due to lack of energy rich organic substrates. The dry matter content in pig and cattle manure usually spans from 2-10% with a major proportion of dry matter being plant fibres, and other non-digestible organic materials from the animal intestines. Co-digestion of manure and other organic substrates solves many environmental problems. The high water content in manure, normally in excess of 90%, ensures that the fermentation bioslurry is diluted sufficiently to allow efficient mixing of substrates and micro-organisms. Nutrient deficiency in single substrates is often balanced when co-digesting multiple feedstock. Carbon, nitrogen, phosphorous, and sulphur must be present in the mixture in optimal proportions; trace elements must also be present in *adequate amounts*, above certain threshold concentrations as well as below toxic levels, for the microbial processes to perform satisfactory (Angelidaki, 2002).

#### 4.5 Thesis studies - biogas process monitoring: introduction of PAT and new concepts

The biological substrates for biogas production are very heterogeneous by nature, and the anaerobic digestion (AD) process is highly complex. There have been several attempts to introduce process control in the AD process by other workers. This thesis summarises a series of studies, where Process Analytical Technologies have been designed, tested, and implemented in the context of ACABS and the Bioenergy Group, SDU. The focus in paper 1 is to make the Theory of Sampling (TOS) operational in the fermentation process regimen. The basic concept of a one-dimensional upward flowing *recurrent loop*, furnishing a TOS-representative sampling point for bioreactors was originally introduced for bioreactor systems by Professor Kim Esbensen. Papers 2 and 3 document at-line and on-line studies of NIR as a tool for *real-time* monitoring and process control of the biogas process using this powerful approach. In these studies, sampling, process analytical chemistry, and multivariate data

analysis are in focus. Supplementary studies and the final paper 4 document that introduction of PAT tools will be possible for real time on-line advanced process control in AD processes.

The AD process has to become a much better controlled process in the very near future, in order to gain significant market share on the global energy scene. Even though AD involves very complex and heterogeneous substrates, PAT tools show promising prospective possibilities of being able to serve as robust monitoring and management tools. The monitoring must be performed in *real time* and must be essentially *non-invasive* in order to provide the needed insight into the process while at the same time be effective and *practical*, especially at small to medium scale plants. The AD process and biogas production today has gained increasing importance as being able to provide major biotechnological solutions for the European energy sector. Biogas production capacities in Europe have currently reached six million tons of oil equivalents/year (toe) in 2006 (Holm-Nielsen, 2007), the target for biogas is 1/3 of all bioenergy consumption, 15 mill. toe year 2015. Biogas production has the potential to be one of the most flexible and adjustable energy sources, and at the same time take care of very problematic organic wastes and substrates. If organic waste is used incorrectly it has major negative impacts on water environment, human and animal health, and air quality.

When full-scale implementations of these types of PAT tools are maturing and when they are commercialised within few years, the next step will be to introduce these more advanced tools into the conventional, traditionally low-tech liquid biofuels fermentation processing sectors. The biorefinery sectors can absorb equally advanced process control regarding PAT instrumentation in comparison to the technology-leading pharmaceutical sector. In the pharmaceutical sector all new technology implementation steps are extremely resource demanding due to the high quality criteria of the American Food and Drug Administration (FDA) in regards to its high hygienic, health, and product standards. However, this is perhaps why this sector has not yet implemented significantly the extremely powerful PAT approach, much to the surprise to most observers.

Perhaps less high-tech sectors will experience the value of PAT. This thesis sets its goal to contribute towards a significant broadening of the PAT concept to very different bioconversion sciences and industry sectors in general and to the biomass-based bioenergy sectors in particular. Bioenergy products comprises of gaseous-, liquid- and solid biofuels for societal utilization various ways

#### **4.6 References**

Angelidaki, I. (ed.) (2002). *Environmental Biotechnology*, notes for course no. 12133, the Technical University of Denmark, Institute for Environment and Resources, Denmark, pp 1-114.

European Commission, (2005). *Biomass – Green energy for Europe*, the European Commission, Directorate-General for Research, Directorate J – Energy, ISBN: 92-894-8466-7

Holm-Nielsen, J.B.; Madsen, M.; and Popiel, P.O. (2006). ‘Predicted energy crop potentials for bioenergy, worldwide, and for EU-25’ in: *World Bioenergy Conference on Biomass for Energy*, conference proceedings, Jönköping, Sweden.

Holm-Nielsen, J.B.; Oleskowicz-Popiel, P.; and Al Seadi, T. (2007). *Energy crop potential for bioenergy in EU-27*, in: *15<sup>th</sup> European Biomass Conference and Exhibition – From Market Research to Deployment*, proceedings, Berlin, Germany

Holm-Nielsen J.B. and Oleskowicz-Popiel P. (2007): The Future of Biogas in Europe: Visions and targets until 2020; Proceedings 3rd Probiogas Workshop – Intelligent Energy Europe, 14-16 June 2007, Esbjerg, Denmark.

Holm-Nielsen J.B.; Njoku S.; Boland L.; Esbensen K.H. ‘Full-scale on-line near infrared monitoring of biogas processes – a Process Analytical Technology baseline study’ (*in prep.*).

IPCC Climate Change, 2007 – The Physical Science Basis; Contribution of Working Group I to the Fourth Assessment Report of the IPCC. ISBN 978 0521 70596-7.

Kamm, B.; Gruber, P.R.; and Kamm, M. (eds), (2006). *Biorefineries – industrial processes and products. Status quo and future directions. Vol. 1*, Wiley-VCH Verlag, ISBN: 3-527-31027-4

Kiel, P.; Holm-Nielsen, J.B.; Boye-Møller, A.R.; Jørgsen, V.; Koefoed, N.; and Hostrup, S.B. (1994). *Ethanol i det grønne bioraffinaderi (Ethanol in the green biorefinery)*, Biomasseinstituttet, Sydjysk Universitetscenter, Sydjysk Universitetsforlag, ISBN: 87-7780-026-5 (in Danish)

Lasure, L.L. and Zhang, M. *Bioconversion and biorefineries of the future*, United States Department of Energy, Pacific Northwest National Laboratory  
<<http://www.pnl.gov/biobased/docs/biorefineries.pdf>>, (June 2, 2007)

Mata-Álvarez, J., Macé, S., and Llabrés, P. (2000). ‘Anaerobic digestion of organic solid wastes. An overview of research achievements and perspectives’, Elsevier, *Bioresource Technology*, vol. 74, pp. 3-16

Malhi, Y., Roberts, J. T., Betts, R. A., (2008): *Climate change, deforestation, and the fate of the Amazon*. Science.

Smeets, E.M.W.; Faaij, A.P.C.; Lewandowski, I.M.; Turkenburg W.C (2007): ‘A bottom-up assessment and review of global bio-energy potentials to 2050’. Elsevier, *Progress in energy and combustion science* 33 p. 56 – 106. DOI: 10.1016/j.peccs.2006.08.001.

Thomsen, M.H. (2005). ‘Complex media from processing of agricultural crops for microbial fermentation’, Springer-Verlag, *Appl. Microbiol. Biotechnol.*, vol. 68, pp. 598-606

United Nations, UN-Energy, 2007: Sustainable Bioenergy: A Framework for decision Makers. Mats Karlsson Chair, UN-Energy, April, 2007



## 5 Biomass Resource Feedstocks

This chapter focuses on the potentials of biomass resources in Europe in a larger perspective. It includes studies conducted by the Bioenergy Department of University of Southern Denmark and ACABS Research Group, Aalborg University Esbjerg. There have been conducted studies of biomass from dedicated rotational farmland in the context of new cropping systems for bioenergy and biorefinery conditions and generation of larger amounts of carbon fixed biomass from the yearly farmland production as primary crop products and by-products.

Potentials of primary farm biomass wastes in the origin of manure is described and documented in this study in addition. This potential of untreated manure is an additional resource for the coming decades of biogas and biorefinery production. Additionally there are initial reflections on sensitivities of how to handle the farmland utilization situation in the future for food-feed-fuels production, and at the same time, how to carefully handle the environment and the natural resources. Ideas are proposed to develop international CODEX framework production conditions to generate primary biomass production and deliver it to the energy market in a sustainable manner. The biomass resource chapter 5.1 was presented as a paper contribution to the 15<sup>th</sup> European Biomass Conference, (Holm-Nielsen et al., 2007)

### 5.1 Biomass Resources – Manure and Energy Crop Potentials for Bioenergy in EU-27

By Jens Bo Holm Nielsen, Piotr Oleskowicz-Popiel, Teodorita Al Seadi  
Proceedings 15<sup>th</sup> European Biomass Conference, Berlin, May, 2007.  
Conference organisers: ETA-Renewable Energies and WIP-Renewable Energies.  
ISBN 3-936338-21-3 & ISBN 978-88-89407-59-X

**ABSTRACT:** Bioenergy gives Europe the best opportunity to reduce GHG emission and secure its energy supply. However, the biomass production should not create additional pressure on the environment. Therefore, for the presented calculations, biomass for energy utilization originates from the cropland of the existing agricultural areas. Permanent grassland, areas of agro-forestry and pasture have not been taken into account. The energy crops potential for the whole EU-27 and for particular countries is presented. Only 10 % of arable land, with poor yield conditions, would produce almost 50 Mtoe of bioenergy. With improved yield and an increased percentage of the arable land dedicated for energy production up to 20% of cropland, more than 180 Mtoe can be achieved. The computed results are compared with the EU energy demand in 2030. As an example, this would be equal to almost 50 % of the transport fuel needs in 2030.

By integrating biomass, wind, hydro, and solar, these energy sources can guarantee even 75 % of the world energy consumption in the near future (2025-2030). Moreover, diversity in energy supply would bring greater economic security and stability for the environment and society.

*Keywords: energy crops, land use, resource potential,  
Additional Keywords: environment, sustainability, security of energy supply, environmental regulation, codex conditions*



## INTRODUCTION

In order to accomplish the Kyoto greenhouse gas (GHG) reduction targets, the modern utilization of biomass has to increase rapidly. Nowadays, world energy supply is dominated by fossil fuels. Biomass covers around 10-15% (app. 45 EJ) of the energy demand. However, most of it is used in developing countries for cooking or heating, very often in inefficient and not sustainable ways. Modern bioenergy – commercial energy production for industrial purposes, power generation or transportation fuels – is estimated for around 7 EJ/yr in 2000 [8], [21].

An increase in the worldwide average air and ocean temperatures, prevalent snow and ice melting and rising levels of sea waters have been attributable to anthropogenic GHG emissions, where the agriculture and waste sectors are playing a significant role. The recently released IPCC WGI fourth assessment report is illustrating the human influence on the global warming effect [18].

It is evident that global climate change is a serious problem humans are facing in the 21<sup>st</sup> century. Human activities have contributed significantly to the build up of concentration of harmful emissions in the atmosphere, with activities like fossil fuel combustion for energy and transport, deforestation, livestock production and paddy rice farming.

Atmospheric concentrations of CO<sub>2</sub> have increased by 35% since the pre-industrial revolution, from a value of 280 ppm to 377 ppm in 2005. The concentrations of methane and nitrous oxide in the atmosphere has also increased from pre-industrial levels of 715 ppb and 270 ppb to about 1774 ppb and 319 ppb, respectively in 2005 [18]. The concentrations of methane increased to more than double within the same period of time.

The primary source of CO<sub>2</sub> since the pre-industrial period can be connected to use of fossil fuel and land use changes. However, for methane and nitrous oxide which have a more damaging potential than CO<sub>2</sub>, emissions have been originating principally from biomass sources, with agriculture accounting for a major percentage.

These increases have led to a 0.6°C rise in the global average surface temperature since 1900, and this is expected to rise further. It is most likely to be detrimental to a large portion of the world population, especially in developing countries and it is expected to affect sectors such as water supply and food production.

It can be seen that activities such as agriculture, deforestation and waste production play a major role in anthropogenic GHG emissions, accounting for about 37% of the total atmospheric emissions. Agricultural practices like the use of inorganic fertilisers and livestock production can lead to emissions of environmentally damaging substances such as ammonia, which contributes significantly to acid rain and acidification of ecosystems, and to further damaging effects on land.

In addition to the environmental impacts of land degradation and climate change, the problem of loss of biodiversity is also encountered. This is as a result of the use of natural habitats for the agricultural (food and non food purposes) or by the overgrazing activities of livestock.

Producing energy from biomass is one of the best ways to reduce GHG emissions. The GHG emissions during all the phases of the production of biofuels can be even reduced to near zero [15], when some combinations of biofuel feedstock and conversion processes is applied, i.e. enzymatic hydrolysis of cellulose to produce ethanol and using biomass as the process fuel. Once the biomass fields can replace part of the agricultural area, it can contribute to improvement of biodiversity. Moreover, it can have positive influence on the soil conditions by adding humus and reducing the erosion [16].

It is estimated that around three-fourths of the biomass which is used for production of food, feed, industrial round wood and traditional wood fuel is lost at some point in processing, harvesting and transport [29]. That recovered biomass could be easily applied for bioenergy. Moreover, higher efficiency of production of food/feed, industrial round wood and traditional wood fuel means that there would be more available biomass for modern bioenergy production. But it has to be remembered that the demand for food/feed and industrials round wood must have priority, otherwise bioenergy production cannot be sustainable.

The potential to upgrade biomass for biofuels is evident, and it can be done by conventional technologies, as for example the fermentation processes for fuels to the transportation sector or by new harvesting and conversion technologies for biofuels and fuel cells [22]. Among these, hydrogen technologies have a great potential, but the development is still far behind large industrial scale. Biofuels are today the best way to direct substitute the oil for transport in the European energy market and can be used in today's ordinary car engines (with minor modifications for high blends, and without any modification in low blends). Among these, ethanol obtained from biomass is one of the most promising sustainable transportation fuels. This compound can be produced from any simple sugar or starchy material. However, great effort is enforced on improvement of the bioethanol production from lignocellulosic materials from forestry and straw/the whole crop from agriculture. Unfortunately, the lignocellulosic polymers are not accessible for micro-organisms; therefore the material must be prior degraded to basic monomers. Different pre-treatment methods such as acid hydrolysis, steam explosion, wet-oxidation etc. [3], [23], [27], [31], [35] are under investigation in laboratories around the world.

According to World Energy Outlook, the energy supply in EU in 2002 was based on 79 % fossil fuels and 15 % nuclear power[15]. Whereas, the transport sector accounts for approx. 30% of the total energy consumption, its dependency on fossils is equal to 98 % [1], of which the main part originates from politically unstable regions of the world. "Oil is the energy source that represents the most severe security of supply challenge for Europe" [2]. A biomass based energy supply would significantly increase energy independency of the EU-27.

New tendencies of such actions have started in countries like Germany and Austria, where the percentage of renewable energy is constantly increasing. Many farmers from these countries are starting paradigm shifts from being food and feed producers towards biomass producers.

The European Commission set up a strategy to replace up to one-fourth of the EU's transport fuels by CO<sub>2</sub>-neutral sources. This ambitious goal can be easily achieved by largely introducing production systems of the second generation biofuels from energy crops. This would also contribute to creation of new jobs, development of new, advanced technology and a more sustainable society.

Biomass yield and its potential differs from country to country, from medium yields in temperate climates to high level yielding in sub-tropic and tropic countries. However, the temperature above 5°C and sufficient water supply in the root zone and in top soils are sufficient to ensure good growing conditions and efficient photosynthesis. High biomass yields can be achieved from the most efficient photosynthesis, the so called C-4 plants such as sugar canes, maize (corn) or sorghum.

Within this, the development of gene-pools for dedicated biomass production has a great potential. For decades, the crop breeding was focused on increasing yields for starch, vegetable oil, sugar or protein, but not for the total crop biomass yield. Research work is carried on in this field on crops like energy maize varieties, where issues like short-day genes, tolerance towards cold growing conditions in late varieties, nutrient/water efficiency etc. are

studied. Improvement of these properties can result in increasing the yield from 10-15 t TS/ha to 20-30 t TS/ha. Potentials are not very well studied for the diversity of growing and climate conditions [20].

Table I and II illustrate the example of Denmark, as a picture of potentials and possibilities for the future European paradigm shift from food and feed production towards biomass production for energy and new biomass based products. Table I presents a shift towards non-food agricultural production. The survey balances the interests of agriculture, forestry production, nature conservation as well as the environmental interests.

**Table I:** Utilization of the area of Denmark and probable future changes [32]

	1995 [1000 ha]	2005 [1000 ha]	2025 [1000 ha]
Arable land	2290	2035	1770
Fallow / brackish	220	150	0
Non-food, single/multi annual	30	150	300
Permanent grassland	200	325	450
<b>Total Agriculture total</b>	<b>2740</b>	<b>2660</b>	<b>2520</b>
Forestry / woods	500	550	650
Fences, ditches, field roads	113	123	133
Heath, dune, bog	200	205	210
Lakes, streams	65	75	95
Buildings in rural areas	230	230	230
Cities, roads, holiday cottages	460	465	470
<b>Total area</b>	<b>4308</b>	<b>4308</b>	<b>4308</b>

The tendency is to minimise the area of fallow lands and increase the energy farming. It can be performed on 10-30 % of the arable land, fallow and non-food area. There will be cultivation systems aiming at maximising energy storage in organic biomass with medium to high net yielding crops per hectare. The energy crops fields must be managed much more rational than traditional food crops in order to achieve maximum energy output balance.

Two future energy scenarios elaborated by the Danish Board of Technology [33] are presented in table II. The dark green scenario indicates the non-fossils society. The realistic view lies between the light and the dark green scenarios; however the goal is to get as close as possible to the dark green scenario, by significantly decreasing the utilization of fossil fuels. In both scenarios highly efficient utilization of energy sources as well as significant energy savings are included. Table II displays the energy net consumption derived from biomass in the span of 119 – 137 PJ of biomass, in the year 2030.

**Table II:** Danish gross energy consumption and two future scenarios [33]

Unit: PJ per year	1992 *) [PJ]	2003 *) [PJ]	2030 [PJ] Light green scenario	2030 [PJ] Dark green Scenario
Oil	348	342	246	0
Coal	324	176	22	0
Natural gas	95	191	146	0
Biomass	54	88	119	67 (137)
Biogas	<1	4	-	45 (90)
Liquid biofuels	-	2	-	22 (47)
Solar heating	<1	<1	4	40
PV (Solar cells)	-	-	4	25
Wind power	3	20	32	90
Net power import	13	- 31	0	0
<b>Total</b>	<b>776</b>	<b>793</b>	<b>573</b>	<b>229 (292)</b>

\* ) Figures from the Danish Energy Authority

Several studies concerning biomass potential have been carried out [9], 0, [12], [13], [40]. The results shown within this paper reflect the theoretical energy crop potential. Additionally, table summarising the annual amount of manure from pig and cattle production in EU-27 is presented. The aim of the paper is to show that a significant shift towards renewable energy system is possible without harming the environment. Future scenarios for an increased consumption of bioenergy in Denmark are depicted. Moreover, the actual increase of bioenergy production from biomass in Germany is presented as a positive example as well as a summarising table with the world theoretical potential of energy crops.

## **RESULTS AND DISCUSSION**

In the presented predicted energy crops potential, general units of energy are used. It is not indicated, whether the biomass will be converted into fuel, electricity, or any other form. For simplifying the calculations, it was assumed, that the heating value of 1 kg dry matter biomass is equal to 18 MJ. For further recalculations, 1 Mtoe (mill ton of oil equivalent) is equal to 44.8 PJ.

All the data concerning total area, agricultural and arable land are taken from the FAO database (2003) [14]. The eventual changes in land use (decrease or increase of arable land) are not taken into consideration. All the calculations are based on the present arable area.

### **Energy crop potential**

Table IV contents registered data of total area of land use for 27 European countries (EU-27). Data shown for the areas of specific interests for biomass production conditions are the total agricultural area and arable land. It is important to underline that forest and permanent grassland might be partly interesting for future energy farming, specifically the forestry areas. The fallow areas might also soon be integrated in arable land or non-food areas. However, for presented potential only arable land was taken into consideration.

Based on the data from Table III, the possible energy crops potential was calculated. The results in PJ and Mtoe are presented in Table IV. The countries with good potential to produce biomass for energy are the ones with high ratio hectares of agricultural land per capita. The new member states: Bulgaria and Romania, with high hectares of agricultural land per capita (both almost 0.7) could make easier the development and implementation of EU bioenergy policies. The average of the EU-27 is 0.4 hectare/capita.

In the coming 10-20 years it will, in all probability be expected to be seen an increasing utilization of crops for energy and industrial purposes. Scenarios of 10-20 or 30 % of the arable land shifting from food and feed towards energy farming will gradually occur. Large European countries, with significant fertile agricultural area of cropland, might play a major role in bioenergy production. The average crop yield of around 20 t TS/ha is considered feasible in the near future. According to Perlack et al. [26] the average yields for switch grass clones, tested in several places in the US, varied from a low 10 total solids per hectare to a high 25 total solids per hectare with most locations having average from 13 to 20 t TS/ha. These results indicated that future yields could be estimated as 20 t TS/ha.

**Table III:** Data of total area and areas of interest for biomass production for each member of EU-27; area data in millions of hectares [11]

	<b>Total area (10<sup>6</sup> Ha)</b>	<b>Agricultural area (10<sup>6</sup> Ha)</b>	<b>Arable land (10<sup>6</sup> Ha) (% of total area)</b>		<b>Hectares of of agricultural land per capita</b>
Austria	8.4	3.4	1.4	17	0.42
Belgium	3.1	1.4	0.8	27	0.13
Bulgaria	11.1	5.3	3.3	30	0.68
Cyprus	0.9	0.1	0.1	11	0.18
Czech Republic	7.9	4.3	3.1	39	0.42
Denmark	4.3	2.7	2.3	53	0.49
Estonia	4.5	0.8	0.5	12	0.63
Finland	33.8	2.2	2.2	7	0.43
France	55.2	29.7	18.5	33	0.49
Germany	35.7	17.0	11.8	33	0.21
Greece	13.2	8.4	2.7	20	0.77
Hungary	9.3	5.9	4.6	50	0.60
Ireland	7.0	4.4	1.2	17	1.09
Italy	30.1	15.1	8.0	26	0.26
Latvia	6.5	2.5	1.8	28	1.08
Lithuania	6.5	3.5	2.9	45	1.02
Luxemburg	0.3	0.1	0.06	24	0.28
Malta	0.03	0.01	0.01	31	0.03
Netherlands	4.2	1.9	0.9	22	0.12
Poland	31.3	16.2	12.6	40	0.42
Portugal	9.2	3.7	1.6	17	0.37
Romania	23.8	14.7	9.4	39	0.66
Slovakia	4.9	2.4	1.4	29	0.45
Slovenia	2.0	0.5	0.2	9	0.26
Spain	50.5	30.2	13.7	27	0.73
Sweden	45.0	3.2	2.7	6	0.36
U. K.	24.4	17.0	5.7	23	0.28
<b>EU-27</b>	<b>433.1</b>	<b>196.6</b>	<b>113.5</b>	<b>26</b>	<b>0.41</b>

**Table IV:** Energy crop potential in EU-27, depending on percentage of utilised arable land and achieved crop yield

Yield	10 % arable land in EU-27		20 % arable land in EU-27		30 % arable land in EU-27	
10 t TS/ha	2,042 PJ	46 Mtoe	4,084 PJ	91 Mtoe	6,127 PJ	137 Mtoe
20 t TS/ha	4,084 PJ	91 Mtoe	8,169 PJ	182 Mtoe	12,253 PJ	274 Mtoe
30 t TS/ha	6,127 PJ	137 Mtoe	12,253 PJ	274 Mtoe	18,380 PJ	410 Mtoe

### Denmark as a case example

When considering the combination with 10 % of the regular rotational farmland (exemplified by 2005 area data), summing up to 230 000 ha, or 20 % - summing up to 470 000 ha, or 30 % - summing up to 700 000 ha, dedicated for energy and biorefining farming, some remarkable results were obtained. By year 2030, in Denmark, it will be more than realistic to reach up to

130 PJ, 170PJ or even 250 PJ by adding 10, 20 or 30 % of the bioenergy from active farming to the existing 90 PJ biomass consumption in the year 2003. By combining different renewable energy technologies, Lund [24] presented the possibility of converting the present Danish energy system into a 100 % renewable energy system. Such a shift is possible in every EU country, when three main technological changes are taken into account: savings on the energy demand side, efficiency improvements in the energy production, and replacement of fossil fuels by various sources of renewable energy. The biomass potential specified for Denmark is summarised in Table V.

**Table V:** Case example of Danish rotational farmland dedicated to bioenergy and biorefining farming year 2030

% of available farmland	PJ	PJ	Mtoe	Mtoe
	10t TS/ha	20t TS/ha	10t TS/ha	20t TS/ha
10	42	84	0.8	1.9
20	84	168	1.9	3.8
30	126	252	2.4	4.7

Available land (AL) equals the sum of arable land, fallow, and non-food land: arable land = 2 035 000 ha, fallow = 150 000 ha, non-food = 150 000 ha, AL = 2 335 000 ha. 10 % of AL approximates 230 000 ha, 20 % approximates 470 000 ha, and 30 % approximates 700 000 ha.

### Manure resources

Biogas from anaerobic digestion can be produced from a variety of biomass types. The primary source, which delivers the necessary micro-organisms for biomass biodegradation and is one of the largest single sources of biomass from food/feed industry, is manure from animal production, mainly from cattle and pig farms. In the EU-27 more than 1500 mill tons of animal manure is produced every year. When untreated or managed poorly, manure becomes a major source of ground and fresh water pollution, pathogen emission, nutrient leaching, and ammonia release. If handled properly, it turns out to be renewable energy feedstock and an efficient source of nutrients for crop cultivation. Table VI depicts the amount of cattle and pig manure produced every year in the European Union.

**Table VI:** Estimated amounts of animal manure in EU-27 (based on Faostat, 2003 [14])

Country	Cattle	Pigs	Cattle	Pigs	Cattle manure	Pig manure	Total manure
	[1000Heads]	[1000Heads]	1000livestock units	1000livestock units	[10 <sup>6</sup> tons]	[10 <sup>6</sup> tons]	[10 <sup>6</sup> tons]
Austria	2051	3125	1310	261	29	6	35
Belgium	2695	6332	1721	529	38	12	49
Bulgaria	672	931	429	78	9	2	11
Cyprus	57	498	36	42	1	1	2
Czech R.	1397	2877	892	240	20	5	25
Denmark	1544	13466	986	1124	22	25	46
Estonia	250	340	160	28	4	1	4
Finland	950	1365	607	114	13	3	16
France	19383	15020	12379	1254	272	28	300
Germany	13035	26858	8324	2242	183	49	232
Greece	600	1000	383	83	8	2	10
Hungary	723	4059	462	339	10	7	18
Ireland	7000	1758	4470	147	98	3	102
Italy	6314	9272	4032	774	89	17	106
Latvia	371	436	237	36	5	1	6
Lithuania	792	1073	506	90	11	2	13
Luxembourg	184	85	118	7	3	0	3
Malta	18	73	11	6	0	0	0
Netherlands	3862	11153	2466	931	54	20	75

Poland	5483	18112	3502	1512	77	33	110
Portugal	1443	2348	922	196	20	4	25
Romania	2812	6589	1796	550	40	12	52
Slovakia	580	1300	370	109	8	2	11
Slovenia	451	534	288	45	6	1	7
Spain	6700	25250	4279	2107	94	46	140
Sweden	1619	1823	1034	152	23	3	26
U.K.	10378	4851	6628	405	146	9	155
<b>EU-27</b>	<b>91364</b>	<b>160530</b>	<b>58348</b>	<b>13399</b>	<b>1284</b>	<b>295</b>	<b>1578</b>

The animal production sector is responsible for 18 % of the green house gas emission, measured in CO<sub>2</sub> equivalent and for 37% of the anthropogenic methane, which has 23 times the global warming potential of CO<sub>2</sub>. Furthermore, 65 % of anthropogenic nitrous oxide and 64 % of anthropogenic ammonia emission originates from the same animal production sector [30].

Table VII shows the biogas and energy potential of pig and cattle manure in EU-27.

**Table VII:** Energy potential of pig and cattle manure in EU-27

Total manure [10 <sup>6</sup> tons]	Biogas [10 <sup>6</sup> m <sup>3</sup> ]	Methane [10 <sup>6</sup> m <sup>3</sup> ]	Potential [PJ]	Potential [Mtoe]
1,578	31,568	20,519	827	18.5

Methane heat of combustion: 40.3 MJ/m<sup>3</sup>; 1 Mtoe = 44.8 PJ

Assumed methane content in biogas: 65%

Table VII reveals that huge amounts of animal manure are produced in Europe. Biogas production through anaerobic fermentation of animal manure is an effective way to reduce greenhouse gas emission, especially ammonia and methane from manure storage facilities. The fermentation of manure alone does not result in high biogas yield, but its high buffer capacity and content of diverse elements has a positive impact on the anaerobic digestion process stability. Higher methane yield can be achieved through co-digestion of manure with other substrates such as energy crops. The digested substrate resulted after the process can be further refined and serves as organic fertiliser, rich in nitrogen, phosphorous, potassium and other macro- and micro-nutrients necessary for the growth of the plants. Utilization of large amounts of animal manure for bioenergy purposes will reduce the nutrient runoffs and diminish the contamination of surface- and groundwater resources.

### **Germany as a positive example of successful application of large amounts of biomass for biofuels production**

There is a significant increase in biomass cultivation for bioenergy purposes in Germany. The biggest production is dedicated to biodiesel. The oil seed crops cover over 1,1mill. ha, which is almost 10 % of the 11.8 mill. ha arable land (Table VIII) and is estimated to reach up to 2 mill. ha or 17 % of the arable land on medium to long terms, producing 40 % of the fuels needed for transportation or 20 % of the primary energy net consumption.

A growing interest for energy crops for biogas has been recently registered, including in Germany. Between 2004 and 2005 the area dedicated to biogas energy crops for biogas production increased over six times (Table IX). Around 80 % of these are represented by maize, harvested for maize silage. Further growth is expected here. Right now Germany has the largest number of biogas plants in Europe (around 3000) [36]. Biogas is produced from co-digestion of manure, industrial organic waste but especially from cultivated energy crops. Energy crops state for over 46 % of the substrates. The share of animal manure is around 24 % of the feedstock applied for biogas in Germany. The biogas potential in Germany was

calculated as 24 bill. m<sup>3</sup> biogas per year. The amount will increase rapidly and boost the number of biogas plants [36].

**Table VIII:** Cultivation of non-food crops in Germany in 2006 [28]

Raw materials	Surface area in ha			Total
	Base areas*		Set aside	
	without energy crop premium	with energy crop premium		
Rapeseed	610,000	172,000	318,000	1,100,000
Oilseed lin	3,000			3,000
Sunflower	4,000		1,000	5,000
Other energy crops (incl. maize)	30,000	188,000	77,000	295,000
Starch	128,000			128,000
Sugar	18,000			18,000
Fibres	2,000			2,000
Pharmaceutical crops	10,000			10,000
Total	805,000	360,000	396,000	1,561,000

\*estimate, as no detailed data and trade statistics available

**Table IX:** Increasing biomass cultivation for biogas production [28]

	2004	2005
	[ha]	[ha]
Maize crop	10,628	66,988
Total crop cultivation for biogas	13,603	86,912

When more and more arable area is dedicated to energy crops, the biodiversity has to be preserved. The solution to avoid monoculture can be rotational cropping or growing different crop types as double cropping system, and developing diversified multi annual cropping system.

Rotational and sustainable cropping systems are developing through projects managed by the Agency of Renewable Resources (FNR). The crops are harvested green and kept ensiled, which gives opportunity of all year long storage. The goal is to use all energy potential of the feedstock – which means, to utilise the whole crop including stalk and leaves. Only when harvested prematurely, the plants contain enough amount of humidity necessary for ensilage. One more advantage of cultivating diverse crops and early harvesting is tolerating even higher pressure of weeds in the fields. Weeds are only disadvantageous, when they are spreading the seeds. Because of the early harvest, the seeds are collected together with the plant. Consequently, the amount of pesticides can be significantly reduced. In addition, weeds can be used for energy production as well [37].

Due to early harvesting, there is a possibility for cultivating a second crop. The late crops can consist e.g. of maize and sunflower, but also wild plants, which would stabilise the agricultural ecosystem.



### **Environmental and nature conservation considerations**

Development and implementation of improved growing systems for the purpose of biomass production for biorefinery utilization will get more and more actual, due to increasing demands for biofuels and a variety of biorefinery products. The commitment of making this kind of shift in using sustainable resources at much larger scale have grown and will grow, in this and in the coming decade. Increasing needs of growth in living conditions in the new EU countries will cause higher energy demand. Such a tendency is common all over the world in rapid developing countries, especially in China or India. On the other hand, in many poorly developed countries in Africa and Asia, the biomass as an energy source is the only way to provide the heat and electricity to the society. The question is how will nature be influenced, and will the environment be harmed by increasing biomass production for the world wide energy sectors and the greatest challenge will be to make the paradigm shift from fossil fuels to renewable resources in a sustainable manner.

As stipulated by this survey it has to be remarked that the biomass for energy and industrial utilization originate from the arable land of the agricultural areas. Permanent grassland areas and the areas of permanent crops and permanent pasture have not been taken into account. For such areas value of the nature has the highest priority. If necessary, small amounts of biomass could be harvested from extensive grassland areas to produce limited amounts of bioenergy [6]. At the same time, it would support the management of species-rich grasslands that maintain their biodiversity value, only when mown occasionally/temporarily after the flowering and birds nesting season.

Crop residues might be significant for bioenergy potential. Removal of large quantities of residues from cropland has to be consistent with research based guidelines in order to do it in a sustainable manner. In some cases removing any residues can cause loss of soil carbon, whereas on other soils some level of removal can be sustainable and even beneficial. Residue removal should not result in increased artificial fertiliser application, in this case the environmental and economic effects can be negative [26]. Increased cropping can be positive if for example energy crop plantations will replace degraded pasture land, largely neutral when higher crop yield is obtained due to shift in cultivation practice from already cultivated area, or severely negative when energy crops cultivation replaces environmentally important areas, like the rain forest in Brazil or i.e. areas under protection of "Natura 2000" in European Union [2].

Another aspect is that introduction of new biomass cropping systems can combine high yields with little fertiliser and pesticide input. For example double cropping systems consists of several crops on the same field [6]. They add to the structural diversity in the field, reduce nutrient leaching and can be harvested more than once a year as green crops.

The increase hectares of perennial crops relative to annual crops can avoid nutrients runoff problem. Moreover, less soil disturbance caused of perennial crops result in less soil erosion and less soil compaction. They also provide better environment for many birds and mammals, compared to annual crops. It will be more profitable to replace annual crops with perennial crops, if bioenergy and other bio-product markets increase the value of biomass. It would increase the environmental benefits: i.e. substitution of maize production with perennial trees and grasses would decrease fertiliser use and improve the soil carbon [26].

Significant biomass availability seems likely to include collateral benefits for biomass production and nature conservation (biodiversity, preservation of soil and water resources), but it requires that environmental guidelines become an integrated part of any future cropping systems and area planning.

According to [2] the recent increase, from about 1% of the EU25 arable land in 2003 to about 3% of arable land in 2005, in crop production for biofuels, it did not result in major land use change or significant environmental impacts. Furthermore, the general farm business profitability might be improved by crop production for biofuels.

It was also mentioned that the species adapted for energy purposes might have lower environmental pressure than food/feed crops. Mostly due to the fact, that they are grown for their energy content and not for their nutrients value. To be profitable for farmers, energy crops for biofuels need lower levels of input costs than conventional crops [2].

**Future perspectives**

Apart from biofuels, many other valuable products like amino acids, enzymes and antibiotics can be produced from organic by-products via fermentation/microbiological conversion. These co-products may be extremely important for overall renewable fuels production. High quality valuable materials might help to realise commercial success in introduction biofuels on the market. In the biorefinery concept diverse renewable feedstock can be converted into fuels, food and feed, and other different chemical compounds [34], [39]. The significant advantage of fermentation processes is that useful products can be produced from biomass such as grains, sugarcane or potatoes but also from any agricultural by-products/wastes containing organic compounds [25].

In this decade, interesting ideas and new concepts are under development, e.g. energy crop biorefineries for gaseous and liquid biofuels. The integrated bioconversion is undergoing a R&D-process aiming to convert lignocelluloses from straw, wood chips and the whole crop silage into biofuels (bioethanol and biodiesel) for the transportation sector, biogas for combined heat and electricity production, and biofertilisers for recycling to the arable land.

**Energy demand**

According to the International Energy Agency [15], the world energy demand will expand by 60 % from 2002 till 2030 and it will reach 16.5 billion toe. It is estimated that fossil fuels will continue to dominate global energy use (around 80 %). The total energy demand for Europe in 2030 is estimated for around 2000 Mtoe.

The calculations show that with 30 % of arable land dedicated for energy crops, up to 20 % of this energy demand can originate from energy crops, under high yielding conditions. With a yield equal to 20 t TS per hectare and 20 % of arable land intended for energy, the biomass from energy crops may provide almost 50 % of European transport fuels needs, presented in Table X below [1].

Table X: Energy demand for transport in EU [1]

	2000 [Mtoe]	2030 [Mtoe]
Gasoline	129.8	141.6
Diesel oil	147.7	223.6
Total	277.5	365.2

The largest increase in renewable energy use, in the coming years, will take place in the EU countries, driven by strong governmental support. Diversifying energy sources would increase the security of supply. Building the new energy structure, based on different bioenergy and RES sources should be the main target, where biomass, wind, solar and hydro become an integrated part of the overall energy strategies, playing an important sustainable role for bioenergy and biorefineries. A diversification of biomass resources is needed and can be foreseen in the medium long term. Biofuels can be made from diverse biomass feedstock. Introducing the second generation biofuels will increase even more the variety of available raw materials for biofuels production. The type of the raw material will strongly depend of the country of origin (sugar cane in Brazil, palm oil in Malaysia and Indonesia etc.) [2].

## Food and feed demand

There are many advantages from utilising bioenergy, but there is also a great challenge, concern and responsibility, that cultivation of energy crops might reduce land availability for feed and food production. Below, the land requirement for food/feed production is calculated to indicate that there should not be any competition between cultivation of energy and traditional crops.

Due to aging of the society in the developed countries the future meat demand will probably decline. Additionally, trend for healthier diet might cause smaller meat demand, especially in the industrialised world [26]. On the other hand, the consumption of animal products is projected to increase in developing countries due to increased living standards. The world consumption of food is estimated to reach 3302 kcal cap<sup>-1</sup> day<sup>-1</sup> in 2050, (in 1998 the average was equal to 2739 kcal cap<sup>-1</sup> day<sup>-1</sup>). It has to be underlined that the food production and food security must have priority above energy crop production. However, the cultivation of dedicated energy crops should not be banned in the regions with nourishment often occurred due to wars, unequal distribution of income, and not always by lack of cropland [29].

Animal product consumption has a significant influence on land use. It is much more land demanding than crop production per 1 kg of product. Animal product consumption is around 15 % of the total calorie intake, but its production occupies more than 70 % of the global agriculture land [29]. The increase of efficiency in animal production system would generate extra land, which could be used for cultivation of energy crops. The demand for feed per kg animal vary from 3 kg dry weight biomass per kg poultry meat in a industrialised production system, to more than 100 kg dry weight biomass per kg bovine meat in a pastoral system with low technological level [29]. The studies indicated that there is potential to increase efficiency of food production, and the obtained surplus of the agriculture area can be easily applied for bioenergy production. Additionally, the diverse biofuels production co-products can serve as a valuable protein supplement for livestock feeding. Table XI presents average food requirement for diverse diets. The food demand was recalculated for grain equivalents. The data was adapted from Wolf et al.[38]. Tables XII and XIII show calculated land requirement for food production world-wide and in the EU-27.

**Table XI:** Global food requirement for three diets: vegetarian: 2388 kcal cap<sup>-1</sup> day<sup>-1</sup> of which 166 kcal cap<sup>-1</sup> day<sup>-1</sup> from animal products; moderate: 2388 kcal cap<sup>-1</sup> day<sup>-1</sup> of which 554 kcal cap<sup>-1</sup> day<sup>-1</sup> from animal products; and an affluent: 2746 kcal cap<sup>-1</sup> day<sup>-1</sup> of which 1160 kcal cap<sup>-1</sup> day<sup>-1</sup> from animal products. The actual population size in 1998 (5.9·10<sup>9</sup> people) and the estimated population size in year 2050 (9.37·10<sup>9</sup> people), as expressed in grain equivalents 10<sup>9</sup> tons dry weight per year. Adapted from Wolf et al. [38].

Diet type	Vegetarian diet		Moderate diet		Affluent diet	
Year	1998	2050	1998	2050	1998	2050
Food requirement [10 <sup>9</sup> tTS ·year <sup>-1</sup> ]	2.80	4.45	5.17	8.21	9.05	14.36

**Table XII:** Land requirement for moderate diet with population size equal to: 5.9·10<sup>9</sup> people and the crop yield 6 t TS grain ha<sup>-1</sup> ·year<sup>-1</sup> (1998); and 9.37·10<sup>9</sup> people and the crop yield 9 t TS grain ha<sup>-1</sup> ·year<sup>-1</sup> (2050);

Moderate diet		
[tTS·year <sup>-1</sup> ]	[ha·year <sup>-1</sup> ]	[ha·person <sup>-1</sup> ·year <sup>-1</sup> ]
5.17 ·10 <sup>9</sup>	8.62 ·10 <sup>8</sup>	0.146
5.17 ·10 <sup>9</sup>	9.12 ·10 <sup>8</sup>	0.097

**Table XIII:** Percentage of present agriculture and arable land required for food production under moderate diet with crop yielding equal to 6 t TS grain·year<sup>-1</sup> (1998); and 9 t TS grain·year<sup>-1</sup> (2050);

	EU-27	World (1998)	World (2050)
Population [people]	4.9·10 <sup>8</sup>	5.9·10 <sup>9</sup>	9.37·10 <sup>9</sup>
Agricultural area [1000 ha]	19.7·10 <sup>7</sup>	50.1·10 <sup>8</sup>	50.1·10 <sup>8</sup>
Arable land [1000 ha]	11.3·10 <sup>7</sup>	14.0·10 <sup>8</sup>	14.0·10 <sup>8</sup>
Land requirement [ha·year <sup>-1</sup> ]	7.1·10 <sup>7</sup>	8.6·10 <sup>8</sup>	9.1·10 <sup>8</sup>
Percentage of agricultural area [%]	36.0	17.2	18.2
Percentage of arable land [%]	62.4	61.4	65.0

Roughly estimating little more than 60 % of the arable land is needed for food production under low crop yield conditions. Of course, with rising population, the land demand for food production will also increase. Additionally, there might be change in diet in developing countries due to enrichment of the societies, especially in China and India. But based on the numbers from Table XIII, there is sufficient land which can be dedicated to energy crops. In addition, the crop yield and efficiency in harvesting is constantly increasing. So, if managed in a sustainable way, there will be no competition between food/feed and energy production in the future, except challenges of integrating the systems to develop symbiotic systems.

The increasing non-sustainability in the last decades in agriculture, human nutrition, waste and waste management was noticed in the developed countries. According to Isermann and Isermann [19] the production and consumption of food and feed is more than 50 % higher than necessary for nutritive energy, fat and protein basic needs for the inhabitants. In Germany the consumption of energy, fat, and animal protein exceeded the requirements by 68%, 83%, and 100%, respectively, in the years 1985-1989 [19]. “Sustainable land management combines technologies, policies and activities aimed at integrating socio-economic principles with environmental concerns so as to simultaneously maintain or enhance production and services; reduce the level of production risks, achieve environmental stability by preserving soil, water quality, and be economically viable and socially acceptable”. [4], [19]

### **Regulatory mechanisms**

During intensified studies, consultations and discussions with politicians, academics, organisations and technology providers, ideas have emerged and crystallised. It is without a doubt necessary to implement internationally regulatory mechanisms to protect the natural resource areas world-wide, and, at the same time, to increase the sustainable production on the commercial agricultural and forestry areas. These mechanisms have to regulate the intensification and optimisation of the production and recovery of the biomass resources on the existing agricultural and forestry areas, utilised in sustainable manners, for the purpose of production of food – feed – fuels, and their symbiotic integration in the contextual approach of biorefineries.

**Table XIV:** Suggestions of regulations of biomass production for food – feed – fuels, in a framework of environmental sustainable and climate protection restoring conditions.

<b>Suggestions of regulations of biomass production for food – feed – fuels</b>	
1.	Reduction of CO <sub>2</sub> emissions targets have to be minimum 70 % of the CO <sub>2</sub> reduction obtained by utilizing CHP conversion of biomass, in comparison with fossil fuel utilization for the process energy.
2.	Biofuels production facilities have to be equipped with the best energy saving and energy efficient technologies (Best Available Technology - BAT standard).
3.	Biomass must only originate from the existing environmentally sustainable commercial agricultural and forestry areas;
4.	The natural resource areas must not be involved in commercial biomass production (e.g. environmental sensitive areas in Europe, natural rainforest areas and all the other nature sensitive areas around the world).

**Table XV:** Suggestions for international cooperation in the frame of EU, UN, FAO or other organisations, for implementing regulatory mechanisms and framework conditions.

<b>International CODEX of Biomass production for FOOD – FEED – FUELS</b>	
a.	Environmentally and economically sustainable biomass production conditions at commercial farming and forestry areas.
b.	Sustainable rural development, paradigm change, new ways of rural economy.
c.	Acting as a tool for restoring climate and preventing further climate change.
d.	Prohibit any involvement of the nature resource areas in commercial biomass production activities.

## CONCLUSIONS

A terminology as biomass for food, feed, fibres, fuels, and future industrial applications is going to be realised and implemented at increasing speed in this and the coming decades. A full paradigm shift has started in this decade going from fossil fuel dependencies towards biomass and accompanying renewable energy recourses based economies for the societies. Biorefineries which are symbiotic integrated thinking and utilization of biomasses of any kind for new products, for industrial and energy use, in sustainable conditions and terms are challenging.

Optimal utilization of biomass converted to valuable industrial and energy products, as high valuable replacements for fossil fuel products, are highly prioritised on the agenda. In the year 2030, it will be possible to meet the EU-27 energy demand up to 20 % of all energy by biomass and biogenic waste, without harming the environment and without competition with food/feed

production. Full integrated utilization of Bioenergy, Wind, Hydro and Solar may significantly raise that number. In the most environmentally friendly scenario renewables could fulfil up to 75% of the entire world energy needs on the long term. The world is getting greener and more sustainable if we are doing a more progressive and faster effort, bearing a more balanced future in mind, climatically, environmentally as well as socio-economically.

## REFERENCES

- [1] Biofuels in the European Union. A vision for 2030 and beyond. Final draft of the Biofuels Research Advisory Council. (2006)
- [2] Biofuels Progress Report. Communication from the Commission to the Council and the European Parliament. Commission of the European Communities, Brussels, [9.1.2007] COM (2006) 845 final.
- [3] Bjerre A.B., Skammelsen Schmidt A.: Development of chemical and biological processes for production of bioethanol: optimisation of the wet oxidation process and characterisation of products. (1997) Risø National Laboratory, Denmark, [Risoe-R-967(EN)]
- [4] Bouma J.: Land quality indicators of sustainable land management across scales. (2002) "Agriculture, Ecosystems and Environment", Vol.88, 129-136.
- [5] Clark J.H., Budarin V., Deswarte F.I.E., Hardy J.J.E., Kerton F.M., Hunt A.J., Luque R., Macquarrie D.J., Milkowski K., Rodriguez A., Samuel O., Tavener S.J., White R.J., Wilson A.J.: Green chemistry and the biorefinery: a partnership for a sustainable future. (2006) "Green Chemistry", Vol.8, 853-860.
- [6] EEA Briefing, (2005-02) How much biomass can Europe use without harming the environment? European Environment Agency. ISSN 1830-2246.
- [7] Eurostat, <http://europa.eu.int/comm/eurostat/> - Detailed statistics on the EU and candidate countries.
- [8] Faaij A.P.C. (2006) Bio-energy in Europe: changing technology choices. Energy Policy 34: 322-342.
- [9] Fischer G., Schrattenholzer L.: Global bioenergy potentials through 2050. (2001) „Biomass and Bioenergy“, vol.20, pp.151-159.
- [10] Hall D.O., House J.I.: Biomass energy in Western Europe to 2050. (1995) "Land Use Policy", Vol.12(1), pp.37-48.
- [11] Holm-Nielsen J.B., Madsen M., Popiel P.O.: Predicted energy crop potentials for bioenergy, worldwide and for EU-25. In: World Bioenergy 2006. Conference and Exhibition on Biomass for Energy, Jonkoping, Sweden, 30 May – 1 June, 2006.
- [12] Hoogwijk M., Faaij A., Eickhout B., de Vries B., Turkenburg W.: Potential of biomass energy out to 2100, for four IPCC SRES land-use scenarios. (2005) "Biomass and Bioenergy", Vol.29, pp.225-257.
- [13] Hoogwijk M., Faaij A., Van den Broek R., Berndes G., Gielen D., Turkenburg W.: Exploration of the ranges of the global potential of biomass for energy. (2003) "Biomass and Bioenergy", Vol.25, pp.119-133.
- [14] <http://faostat.fao.org> – Food and Agriculture Organisation of the United Nations, FAO Statistical Databases.
- [15] IAE (2004) World Energy Outlook, International Energy Agency, IEA Publications, France.
- [16] Ignaciuk A., Vohringer F., Ruijs A., van Ierland E.C.: Competition between biomass and food production in the presence of energy policies: a partial equilibrium analysis. (2006). "Energy policy" Vol.46: 1127-1138.

- [17] IIASA (2002). [http://www.iiasa.ac.at/cgi-bin/ecs/book\\_dyn/bookcnt.py](http://www.iiasa.ac.at/cgi-bin/ecs/book_dyn/bookcnt.py).
- [18] IPCC, Climate Change 2007: The Physical Science Basis; Summary for Policymakers. The IPCC 4<sup>th</sup> Assessment Report.
- [19] Isermann K., Isermann R.: Food production and consumption in Germany: N flows and N emissions. (1998) "Nutrient Cycling in Agroecosystems", Vol.52, 289-301.
- [20] Kesten E., KWS Saatgut AG, Einbeck Germany, (2005), Energiepflanzenbau als Zukunftschance aus der Sicht eines Pflanzenzüchters, presented at the conference Optimale Gewinnung und innovative Verwertung, Steyr, Austria.
- [21] Kim. S., Dale B.E., (2004), Global potential bioethanol production from wasted crops and crop residues. "Biomass and Bioenergy", Vol.26, 361-375.
- [22] Larsen, Kossmann, Sønderberg Petersen (2003), Risø Energy Report 2, Konklusioner og anbefalinger.
- [23] Lloys T.A., Wyman Ch.E.: Combined yields for dilute sulphuric acid pre-treatment of corn stover followed by enzymatic hydrolysis of the remaining solids. (2005) Bioresource Technology, 96:1967-1977.
- [24] Lund H.: Renewable energy strategies for sustainable development. (2007) "Energy", Vol.32, 912-919.
- [25] Ohara H., (2003), Biorefinery. "Applied Biotechnology and Microbiology", Vol.62, 474-477.
- [26] Perlack R.D., Wright L.L., Turhollow A.F., Graham R.L., Stokes B.J., Erbach D.C.: Biomass as feedstock for a bioenergy and bioproducts industry: the technical feasibility of a billion-ton annual supply (DOE/GO-102005-2135, Oak Ridge National Laboratory, Oak Ridge, TN, 2005.
- [27] Rudolf A., Alaksrawi M., Zacchi G., Liden G.: A comparison between batch and fed-batch simultaneous saccharification and fermentation of steam pretreated spruce. (2006) Enzyme and Microbial Technology, 37: 195-205.
- [28] Shusseler P. Fachagentur Nachwachsende Rohstoffe e.V. (FNR - Agency of Renewable Resources). Personal communication, 2006.
- [29] Smeets E.M.W., Faaij A.P.C., Lewandowski I.M., Turkenburg W.C.: A bottom-up assessment and review of global bio-energy potentials to 2050. (2007) "Progress in Energy and Combustion Science", Vol. 33, 56-106.
- [30] Steinfeld H., Gerber P., Wasenaar T., Castel V., Rosales M., de Haan C. (2006) Livestock's long shadow. Environmental issues and options. Food and Agriculture Organisation of United Nations.
- [31] Stenberg K., Tengborg Ch., Galbe M., Zacchi G.: Optimisation of steam pretreatment of SO<sub>2</sub> – impregnated softwoods for ethanol production. (1998) Journal of Chemical Technology and Biotechnology, 71: 299-308.
- [32] Teknologinævnet (The Danish Board of Technology) (1994), Biomasse til energiformål – et strategisk oplæg, ISBN: 87-89098-90-0.
- [33] Teknologinævnet (The Danish Board of Technology) (1994), Fremtidens vedvarende energisystem – et lysegrønt og et mørkegrønt scenarie, ISBN: 87-89098-89-7.
- [34] Thomsen M.H. (2005) Complex media from processing of agriculture crops for microbial fermentation. Applied Microbiology and Biotechnology: 68: 598-606.
- [35] Varga E., Schmidt A.S., Reczey K., Thomsen A.B.: Pretreatment of corn stover using wet oxidation to enhance enzymatic digestability. (2003) Applied Biochemistry and Biotechnology, 104.
- [36] Weiland P. (2006) Biomass Digestion in Agriculture: A successful pathway for the energy production and waste treatment in Germany. Engineering in Life Sciences, 6:302-309.

- [37] Wiese C.: Vom Landwirt zum Energiewirt. FechnerMedia for VRD Energie Stiftung (2004).
- [38] Wolf J., Bindraban P.S., Luijten J.C., Vleeshouwers L.M.: Exploratory study on the land area required for global food supply and the potential global production of bioenergy. (2003) "Agricultural Systems", Vol. 76, 841-861.
- [39] Wyman Ch. (1999) Biomass Ethanol: Technical progress, opportunities, and commercial challenges. Annual Review of Energy and the Environment, 24: 189-226.
- [40] Yamamoto H., Yamaji K., Fujino J.: Evaluation of bioenergy resources with a global land use and energy model formulated with SD technique. (1999) "Applied Energy", Vol.63, 101-113.





## 6 Biogas – AD in general

This chapter is part of a book based on the EURO-Ph.D. Summer School – “Biotechnology in organic solid waste management; from solid waste disposal to resource recovery.” Wageningen, NL, July, 2003. Currently waste management schemes are generally based on a hierarchy of three principles, which include **a.** Waste prevention or reduction, **b.** Recycling and reuse and **c.** disposal of wastes (Lens et al. 2004).

Emission of methane into the atmosphere is an important source of greenhouse gases. Organic wastes therefore receive much attention in waste management. Anaerobic digestion is an important biotechnological tool to produce biogas, closing the loop, instead of emissions from uncontrolled organic degradation. In combination with separation or post treatment technologies or in combination with composting of organic wastes the end product can be utilised as a soil quality improver in agriculture and horticulture. Wet organic wastes of all kinds with a total solid content below 30-35 % have its most important treatment pathway through anaerobic digestion for both renewable energy and biofertiliser production. Hygienic precautions have to be taken into account for some fractions of the organic waste, specifically the animal by-products categories. Biological waste treatment in particular can lead to more effective resource management, as well as the development of more sustainable practice and methods (Lens et al., 2004).

Biogas is a very old biotechnological method to convert carbon sources of heterogeneous structure through bacteriological biodegradation processes to the primary product - the biogas - , which is a combination of CH<sub>4</sub> and CO<sub>2</sub>. The second product is the biofertiliser, containing the nutrients and the non-degrading lignocellulosic fibres. For decades the biogas process has been studied in laboratories in details. One of the first countries to move the biogas processes into full-scale optimisation developmental areas, including R&D&D projects, has been Denmark, in the 1980ies and 1990ies. Today many countries, like Austria, Germany, Sweden and Switzerland among others, are running large scale research and demonstration programmes to develop biogas technologies in all kinds of applications and to boost the biogas sector. This has turned biogas into some of the fastest growing bioenergy and biowaste treatment sectors.

### 6.1 Manure-based biogas systems – Danish experience

*By J.B. Holm-Nielsen and T. Al Seadi*

© 2004 IWA Publishing. *Resource Recovery and Reuse in Organic Solid Waste Management*.  
Edited by Piet Lens, Bert Hamelers, Harry Hoitink, Werner Bidlingmaier. ISBN: 1 84339 054 X.  
Published by IWA Publishing, London, UK

#### THE PLACE OF BIOGAS IN THE DANISH ENERGY STRATEGY

##### Introduction

The long-term strategy plan for energy of the Danish Government – Energy 21 – emphasizes the fact that the main concern of the Danish energy planning is the environment. The main objective of Energy 21 is therefore a 50 % reduction of the CO<sub>2</sub> emissions from the entire society by the year 2030, compared with the average level of 1988–1990. This can be achieved by out-phasing fossil energy and in-phasing renewable energy sources.

The biogas sector has therefore received growing attention and recognition in Denmark during the last decade and is part of the CO<sub>2</sub> emission reduction strategy together with other bioenergy systems. Biogas shall provide 20 PJ (1 PJ = 10<sup>15</sup> J) to the national energy production by the year 2030, an eightfold increase, compared with the level in 1990, and by this the

highest growth compared with other renewable energy sources. The experience of the last years proved that the strategic objectives of Energy 21, in the area of biomass for energy, are rather difficult to reach due to relatively high costs of technology for solid biomass conversion for combined heat and power (CHP) generation, but this does not include anaerobic digestion technologies.

### Biogas state of the art in Denmark

In 2002, 3.35 PJ biogas was produced in Denmark (Table 17.1). Most of it originates from the large-scale, manure-based co-digestion plants, wastewater treatment plants and landfill plants. Commercial farm-scale biogas plants are increasing in numbers and production. Farm-scale biogas production in 1999 was 0.070 PJ, 0.129 PJ in 2000, 0.179 PJ in 2001 and 0.380 PJ in 2002. The theoretical biogas potential in Denmark is estimated at 37 PJ of which 26 PJ (70 %) is represented by animal manure (Table 17.2). Energy 21 forecasts 20 PJ by the year 2030 that shall mainly emerge from manure-based biogas plants (Nielsen et al. 1998).

Table 17.1 Biogas plants and production in Denmark, 2002 (Danish Energy Agency 2002).

Type of biogas plant	Amount of plants	Production 2002 (PJ)
Wastewater treatment plants	64	0.875
Landfill plants	26	0.604
Industrial waste treatment plants	5	0.150
Manure-based plants		
Centralised, co-digestion	20	1.342
Farm-scale plants	45	0.380
Total	160	3.351

Table 17.2 Potential, actual production and targets for biogas in Denmark (Danish Energy Agency 2002).

	Potential (PJ)	Production 1999 (PJ)	Target production	
			2012 (PJ)	2030 (PJ)
Animal manure	26.0	0.50	5.00	14.0
Sewage sludge	4.0	0.79	1.15	1.5
Organic waste from industries	2.5	0.81	0.75	1.5
Household waste (organic)	2.5	0.01	0.50	2.0
Green waste (parks and gardens)	1.0	0.00	0.20	0.8
Landfill gas	1.0	0.55	0.60	0.2
Total	37.0	2.66	8.20	20.0

### The overall framework for the development of manure-based biogas systems in Denmark

The development of manure-based biogas systems in Denmark takes place within a framework of favourable preconditions (Al Seadi 2000), which can be resumed as follows.

#### *General environmental and energy targets*

- Danish Government target of 20% reduction of the CO<sub>2</sub> emissions by 2005, compared with the level of 1988-1990 in average.

- Danish Environment Protection Agency target of recycling 30 % of domestic waste by 2004 and 50 % by long term (Danish Ministry of Environment and Energy 1998).
- Danish Energy Agency target of a fourfold increasing of the biogas production in 2005, compared with 1995 level (Danish Ministry of Environment and Energy 1996).

*Government research, development, and demonstration programmes*

- Energy research programmes: funding of research, development, and demonstration projects (R&D&D).
- Renewable energy development programme: grants for reviews and demonstration (pilot) projects.
- Follow-up programmes collection, systematization, and dissemination of the gathered experience among farmers, plant operators, consulting companies, plant constructors and authorities.

*The legislative push*

- Requirement of 9 months slurry storage capacity of animal manure and a concomitant restriction of the season for slurry application in spring and early summer.
- The harmony rules, restricting the amount of manure applied per hectare.
- Control and regulation of the application of waste products for agricultural purposes.
- Interdiction to landfill any organic wastes.
- Heavy taxation of waste incineration and exemption of recycling.
- Power companies obliged to purchase electricity produced on biogas at prices according to the law.

*Basic economic preconditions*

- Government investment grants of 20–40 % of the investment costs to build a biogas plant, lowered to 0–20 % in year 2000.
- Biogas and heat from biogas are exempted from energy taxation.
- State production grant of DKK 0.27 per kWh electricity produced.
- Building a biogas plant is financed by long-term (20 years) low-interest rate loans.

*Other important favorable issues*

- Up to 48 million tonnes animal manure per year are produced in Denmark.
- Food and fodder processing industries concentrated in the high-manure density areas, making co-digestion of organic wastes convenient and economically advantageous.
- Positive perception of the advantages of co-digestion of a variety of biomasses, supported therefore by the veterinary and environmental authorities (Bendixen 1999).
- Possibility of selling the heat through the district heating systems, which are widespread in Denmark. In the future the heat will be used for industrial as well as processing purposes.
- Heat demand is widespread in the society. House heating is necessary 8–10 months per year in Denmark.

## **BIOGAS TECHNOLOGIES**

### **Centralized co-digestion plants**

The first generation of centralized co-digestion plants in Denmark was built in the early 1980ies with the only aim of producing renewable energy (Danish Energy Agency 1995). The acknowledgement of the environmental consequences of the intensive animal production, strengthening of the legislation regarding manure storage and application, regulations of waste

production and treatment increased the interest for biogas plants, which proved to play a new role as providers of manure storage, manure distributors, and organic waste treatment facilities.

In recognition to this, the Danish Government financed successive R&D&D programmes and follow-up programmes which proved that the co-digestion of manure and organic industrial waste concepts for producing biogas offer integrated solutions to a range of environmental problems in relation to agriculture, organic waste treatment, and renewable energy production (Danish Energy Agency 1995).

Twenty manure-based centralized co-digestion plants are in operation in Denmark, processing approximately 1.5 million tonnes animal manure and 325,000 tonnes industrial biomass per year, producing 50.1 million m<sup>3</sup> biogas (1999 figures).

The centralized co-digestion concept was continuously developed and improved, and represents today an integrated system of renewable energy production, manure and organic waste treatment, and nutrient recycling, generating intertwined agricultural, and environmental benefits. The main streams of the integrated co-digestion concept are shown in Figure 17.1.

Animal manure and slurry are collected from the pre-storage tanks at the farms, transported to the biogas plant, mixed and co-digested with maximum 15–25 % digestible organic wastes (also called alternative biomass) from food processing industries and municipalities, and submitted to a controlled sanitation process ensuring effective pathogen reduction. New EU legal standards have been adopted in October 2002 by the regulation (EC) No. 1774, laying down health rules concerning animal by-products not intended for human consumption.

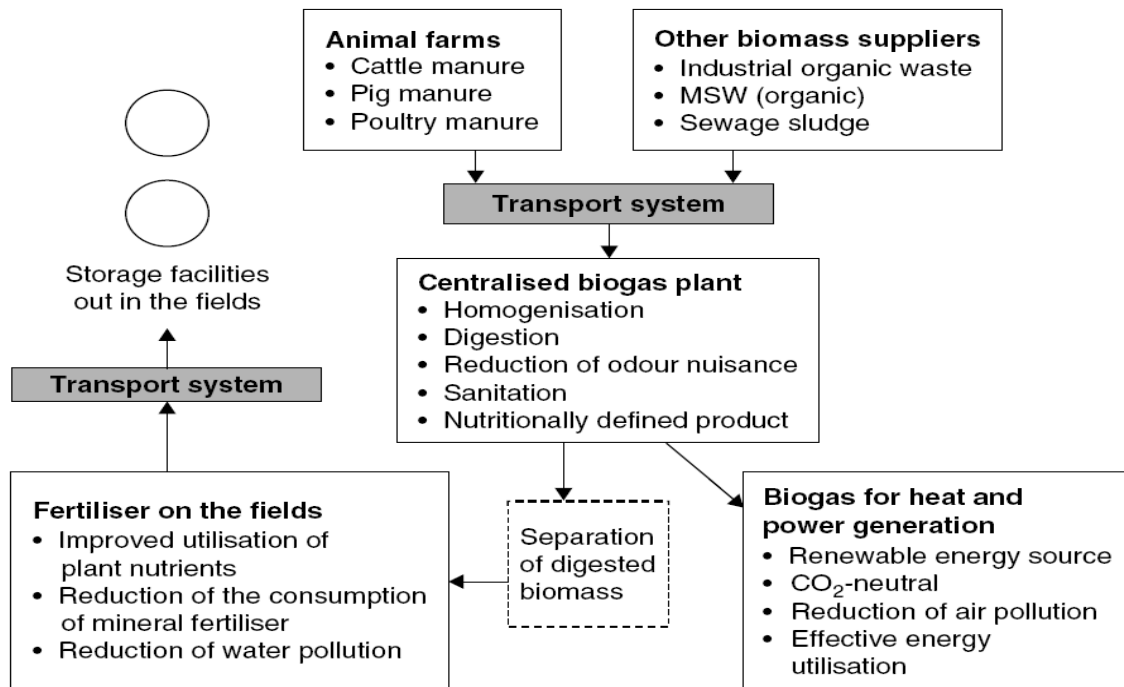

Figure 17.1 The main streams of the integrated concept of centralized co-digestion plant.

The digestion process takes place at mesophilic (30–40°C) or thermophilic (50–55°C) temperatures. The retention time in the reactor is of 2–25 days. A controlled sanitation process takes place as well, where pathogens are effectively reduced, and the disease/pathogen cycles are broken. The digested biomass is transferred to the storage tanks, covered with a gas proof membrane for the recovery of

the remaining biogas production (up to 15 % of the total biogas volume). Some plants are equipped with installations for fiber and phosphorous separation of the digested biomass, these technologies are under strong development from year 2000 onwards (Al Seadi and Møller 2003).

The digested biomass is transported back to the farmers to their decentralized storage tanks, placed out in the fields, as a pathogen free, nutritionally defined bio-fertilizer, to be integrated in the fertilization plan of each farm and applied to crops during the growing season. The slurry suppliers got up to 40 % investment grants to build their slurry storage tanks back in the 1990ies. The farmers receive back only that amount of digested biomass containing the amount of plant nutrients – nitrogen (N), phosphorus (P), and potassium (K) – they are allowed by law to apply on their crops. The excess of digested biomass is sold to arable farms in or out of the region.

The biogas plant effectuates and supports the cost of the biomass transport.

The biogas produced is used for CHP generation. The power is sold to the grid and the heat is distributed through the district heating to heat consumers and some of it, in some cases, used by the biogas plant for process heating. The biogas production cycle represents an integrated system (Figure 17.1) of renewable energy production, resources utilization, organic wastes treatment, and nutrient recycling and redistribution, generating intertwined agricultural, energetic, and environmental benefits, as listed below:

- renewable energy production
- cheap and environmentally healthy organic waste recycling
- less greenhouse gas emission
- pathogen reduction through sanitation
- improved fertilization efficiency
- less nuisance from odours and flies
- economical advantages for the farmers

The Danish livestock counts approximately 2.4 million livestock units, producing approximately 48 million tonnes of manure per year, of which approximately 1.5 million tonnes is supplied to the biogas plants (2000 figures).

The co-digestion of animal manure with 15–25 % organic industrial wastes is done in order to increase the biogas yield (Danish Energy Agency 1995). It is estimated that 75 % of the suitable and accessible organic wastes are already utilized for biogas production in Denmark. The paucity of organic waste can become a barrier for the further development of centralized co-digestion systems, thus one of the actual issues is to find ways to improve the biogas yield from animal manure, with less dependence on organic waste addition.

### **Farm-scale biogas plants in Denmark**

Forty-five farm-scale biogas plants are in operation in Denmark in 2003. These plants were built from 1980 up until now, the largest numbers in the last 5–6 years. Most of the biogas plants are co-digesting animal manure and small amounts of organic waste, primarily from food industries.

The new actions and initiatives concerning farm-scale biogas plant development, ongoing from 1995, targeted primarily the large-scale pig farms in Denmark, with a high consumption of heat and power. This resulted in a range of technical and conceptual improvements and some promising economical results for the newly built plants. The analyses carried out as part of the follow-up programme for farm-scale biogas plants showed that the main cause for poor economy for most of the plants is related to high investment and operational costs and low stability of the anaerobic digestion process and operational stability of the gas engines (Hjort-Gregersen 1998). These problems can be overcome by better education, training, and management.

The farmers' interest in farm-scale plants is growing nowadays, as they are interested in the business opportunities and the environmental assets that farm-scale biogas production offers.

Three basic concepts of farm-scale biogas plants have been built and operated in Denmark until now. The main characteristics of the three basic concepts are briefly presented below.

*The “Black Smith” plant concept*

The main parts of this type of plant are given in Figure 17.2: a horizontal stainless steel digester (150–200 m<sup>3</sup>), equipped with a slowly rotating stirring system, a pre-storage tank for manure, a storage tank for digested biomass, a storage capacity for biogas, and a CHP unit (Hjort-Gregersen 1998). The plant co-digests animal manure and fish oil waste. The process is mesophilic up to semi-thermophilic (35–48°C) and the hydraulic retention time is 15–25 days. The gas yield is normally of 40–50 m<sup>3</sup> biogas per m<sup>3</sup> digested biomass. Bigger plants of this concept are now equipped with vertical black steel biogas digesters (800–1000 m<sup>3</sup>), which are equipped with slowly rotating stirring propellers.

*The “Soft Top” plant concept*

The schematic representation of the concept is shown in Figure 17.3. Typical for this type of plant is the “two in one” (Hjort-Gregersen 1999) slurry storage and digester tank, covered by a gas tight “Soft Top” membrane for the collection of biogas.

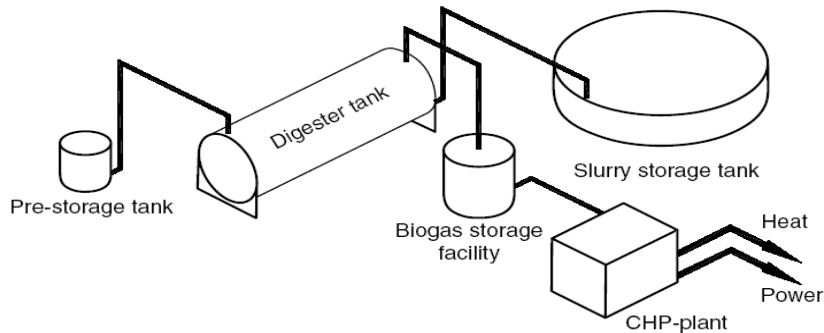

Figure 17.2 Schematic representation of the Black Smith plant concept (Hjort-Gregersen 1999).

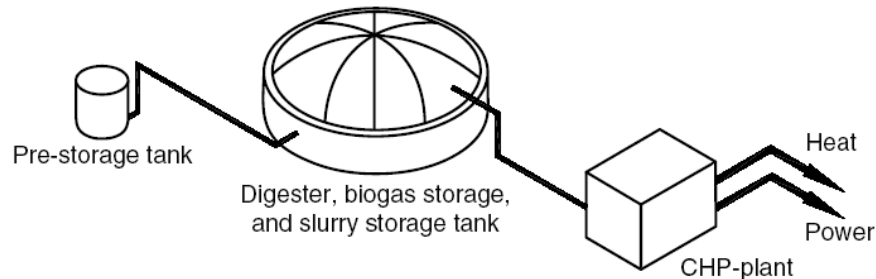

Figure 17.3 Schematic representation of the Soft Top plant concept (Hjort-Gregersen 1999).

The Soft Top membrane floats on the surface of the slurry by means of a ring, pressing its margins by the edge of the tank, and is inflated by the emerging gas production. The tank is stirred by an electric propeller. Furthermore, there is a pre-storage tank for slurry and a CHP-unit. The process temperature is 22–25°C and the hydraulic retention time is more than 50 days.

*The “Soft Cover” plant concept*

The main components of the Soft Cover are presented in Figure 17.4. The membrane in the top of the tank is fastened on the edges of the tank and supported by a central mast and functions as a gas storage facility. The digester is slimmer and is built inside the storage tank, placed tangentially to it. The 200 m<sup>3</sup> digester is insulated and stirred with an electrical propeller stirrer. The process temperature is 35–37°C. The new trend for the farm-scale biogas plants is to build integrated plants for upgrading and processing digested manure into two or several fractions: solid (fibres) and liquid (nutrient concentrates and process water).

*Investment and economy of farm-scale biogas plants*

Table 17.3 compares the characteristics of the three concepts and their initial investment costs. Economic results from a set of improved concepts indicate that Danish farm-scale biogas plants are at the point of commercial breakthrough (Dansk BioEnergy 1999).

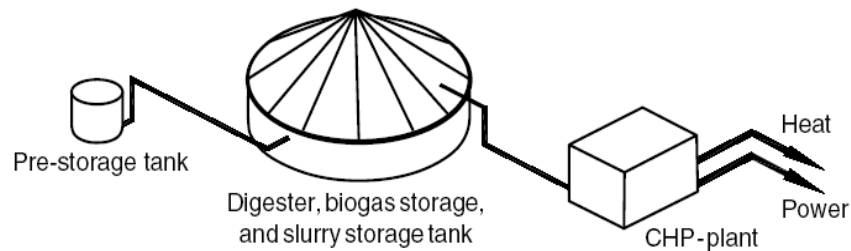

Figure 17.4 The schematic representation of the Soft Cover concept (Hjort-Gregersen 1999).

Table 17.3 Initial investment costs of the basic farm-scale plant concepts (Hjort-Gregersen 1999)

	Black Smith plant	Soft Top plant	Soft Cover plant
Capacity (m <sup>3</sup> /day)	12	6	14
Electricity production capacity (kW)	85	15	37
Investment (1000 DKK)	2.150	620	1.113
Investment grants (1000 DKK)	650 (30%)	186 (30%)	723 (65%)
Net investment (1000 DKK)	1.500 DKK,	434 DKK,	390 DKK,
	200.000 Euro	58.000 Euro	52.000 Euro

It is a clear precondition that they must be technically well functioning, and sufficient biogas can be derived from the available biomass. Heat utilization is important to the economic results, though electricity sales are the primary source of revenues. Increased value of energy production may be achieved in some cases by using the most efficient CHP-systems, electric output of up to 38 % - 50 % heat or more. The ongoing concentration of livestock production increases farm-scale biogas



opportunities in Danish agriculture. The economic incentives seem to be strong enough to initiate a major enlargement of the number of farm-scale biogas plants.

Consequently, economic results have to be further improved. Future objectives in research and development are: refined and cheaper plant concepts, improved operation stability, search for applicable supplementary biomass types, development and highly efficient small CHP-systems, or alternatives in the future as fuel cells and microturbines.

## **TECHNICAL EXPERIENCE WITH CENTRALISED BIOGAS PRODUCTION IN DENMARK**

A range of technical and non-technical improvements affected the concept of centralized co-digestion, so that there is a good foundation today for establishing commercial centralized biogas plants. The economy of the plants can still be vulnerable in some aspects. The premises for establishing a new plant must therefore be carefully evaluated in each particular case ensuring maximum quality standards in order to avoid problems during the start up and during operation.

The basic premises for establishing a biogas plant are:

- The existence and accessibility of the biomass resources, both animal slurries and organic wastes.
- A group of co-interested farmers, as suppliers of fresh slurries and receivers of the digested biomass.

• Sales market for the produced biogas, either for heat or for heat and power production. Sales of heat imply the existence of a district heating net, to ensure the utilization of the produced heat.

- An established form of organization, able to plan, build, and operate the plant. All the plants attempt to achieve a high and stable gas production and by this an acceptable economic situation.

The economic situation depends not only on the level of production, but on a multitude of other factors such as the quality of the initial planning and organizing work, operational stability, low maintenance costs, interactive management of the plant etc.

### **Concepts and technologies**

In the 1990ies, Danish efforts have focused on developing large centralized co-digestion biogas plants and during the last 3 years also to improve the farm biogas plants by utilizing the entire biogas sector experience at all scales of biogas plants. From the outset, the centralized plant concept was solely based on the utilization of animal manure delivered from a group of suppliers within a radius of up to about 10 km from the plant. The addition of various categories of organic waste from industry soon proved to be beneficial, and in recent years, some of the plants have been using wastewater sludge and source-separated household wastes, the organic fraction. The supplementary waste, for which a receiver fee is often paid to the biogas plant, usually yields more gas per m<sup>3</sup> than animal manure. Transport and storage systems are also connected to the centralized plants. In some cases, a post-treatment of the digested slurry occurs (separation). The plants are well suited for recycling and redistributing the slurry and nutrients, partly to the group of suppliers, partly to other farmers like arable farmers who can use the surplus slurry and crop nutrients. By doing so, the plant solves an important assignment for agriculture and the environment. The processing of slurry in the biogas system reduces obnoxious smells during spreading, and the slurry is also more homogenous and its nutrient content easier to declare and apply on cropland.

Moreover, the numbers of disease germs are significantly reduced.

The size of the 20 centralized co-digestion plants in operation varies from 25 m<sup>3</sup> to more than 500 m<sup>3</sup> of feedstock per day. Half of the plants are based on mesophilic operation and the other half on thermophilic operation. Considerable technological progress has been made in recent years concerning the centralized plants:

- Higher and more reliable production through the addition of organic waste as well as through technical improvements, gas extraction from storage tanks, and improved control and regulation.
- Development of pumps, mixers, and heat exchangers resulting in savings in power consumption and fewer interruptions of operation.
- Improved and less expensive gas purification and gas transport using low pressure systems.
- Criteria for neutralizing infectious matter.
- Techniques for preventing obnoxious smell around the plants.
- Cheaper slurry transport and improved logistics concerning redistribution and utilization of slurry.

As far as the farm plants are concerned, corresponding progress has occurred in the fields of biogas production and technology. Development efforts are being stated partly on high-technology plants and partly on simpler, cheaper plants with a covered slurry tank and the reactor as an integrated section.

The primary conclusion is that the construction of technically well-functioning plants is now possible. Moreover, the plants can be adopted to meet various requirements and preferences regarding the production and utilization of biogas, which can unite agricultural, environmental, and energy-related interest.

Due to better organization, technical and technological improvements, the operational stability has considerably improved and is considered to be one of the explanations of the increased biogas production. It has been proven that operational stability has also a beneficial effect on the anaerobic digestion process. Important steps forward have been made in order to better understand and control the anaerobic process and the parameters that are influencing it. A combination of practical experience and research results has improved the know-how about anaerobic digestion process among plant operators and suppliers.

## **Biogas purification**

### *Hydrogen sulphide removal*

Simple and cheap methods of biogas purifying have been developed. Draining of water (H<sub>2</sub>O) and removal of hydrogen sulphide (H<sub>2</sub>S) are the main problems concerning biogas purification (Ellegaard and Kristensen 1997).

Removing H<sub>2</sub>S from biogas is necessary for environmental considerations regarding emissions to the atmosphere if the biogas is burned in a boiler. Furthermore, if the biogas is used in a gas engine for CHP generation, like in most cases in Denmark, the level of H<sub>2</sub>S must not be higher than 500–700 ppm on conventional gas engines. This is necessary in order to avoid increased corrosion and rapid and costly deterioration of the lubrication oil and engine spare parts.

The levels of H<sub>2</sub>S in biogas are various and depend on the chemical composition of the supplied biomass. If operating on manure alone, the levels of H<sub>2</sub>S can reach up to 3000 ppm. Co-digesting manure with other biomass can increase or reduce the concentration of H<sub>2</sub>S in the produced biogas, but wastes can contain ferrous compounds like FeCl<sub>3</sub> that will keep the H<sub>2</sub>S content in biogas at a suitable low level for running the gas engine.

The earlier method to reduce the H<sub>2</sub>S content in the biogas, based on adding an iron–chloride to the supplied biomass, proved to be expensive if used continuously and aggressive in corrosion (Ellegaard and Kristensen 1997; Al Seadi 2000).

A method largely used in Denmark is the biological oxidation, obtained by injecting 2–5% v/v air into the raw biogas. The oxidation of H<sub>2</sub>S will take place resulting in formation of sulphur and/or sulphurous acid:

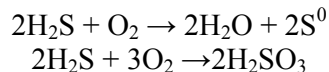

Addition of air can be done in the top space of the digester, in a separate purification tank, with better control, or in a post-digestion and storage tank at the biogas plant.

#### *Low-pressure gas transmission*

Low-pressure systems proved to be more suitable for the transmission of biogas compared to high-pressure systems and became widespread in the 1990ies. As a consequence, operational stability increased and gas transmission costs were considerably reduced. All biogas transmission systems are equipped this way today.

#### *Odour control*

A significant odour reduction occurs when digesting the manure, making it easier to handle and to spread on the fields. Nevertheless, the centralised co-digestion plant can be a source of odour nuisance if some important measures considering odours prevention are not taken when building the plant. During the last years, one of the barriers for increasing the number of centralized plants in Denmark has been the odour problem around the plants (Hjort-Gregersen 1999). Special efforts of finding solutions to the problem ended in some important improvements (Hjort-Gregersen 1999).

The causes of odour around the plant can be multiple (Hjort-Gregersen 1999).

Some of the most frequent are the territorial emplacement of the plant in the immediate neighborhood of the settlement areas, uncovered or not tight storage tanks, handling feed stocks outdoors, insufficient ventilation, insufficient suction from storage tanks, deficient treatment of the air obtained from the suction system, supply of heavily smelling feedstock, etc.

Special attention must be given to the treatment of the air resulting from the suction systems (Danish Energy Agency 1995). Passing the air through a bark filter or a compost filter (bio-filter) will result in biological cleaning of the air. Compost filters are a relatively new method, cheap to establish, but there is not sufficient operational experience with it. The biogas plant in V. Hjermitsev uses the controlled compost filter with good results (Al Seadi 2000).

Active coal filters are also used, but the need of regular replacement of the saturated filters can be relatively costly (Danish Energy Agency 1995). The method is used at Hashoej biogas plant. Cleaning the air via combustion in a boiler (catalytic combustion) with generation of process heating for the biogas plant is used at Lintrup and Nysted biogas plants. Combustion in engines, together with biogas (catalytic combustion with regenerative heat exchanging) is currently used at Blaabjerg biogas plant. The method is rather expensive, but the results are fairly positive (Al Seadi 2000).

### **Biomass handling**

#### *Pumps and stirring systems*

The pumps and the stirring systems are the key elements of handling the biomass (Danish Energy Agency 1995). Great efforts have been made in order to solve a range of technical and economical problems related to it and to find pumping systems and mixing techniques suitable for this kind of biomasses. Most of the plants are currently using eccentric snail pumps, mono pumps for continuous feeding and extraction of biomass from the digesters, demanding high pressure and low flow. Centrifugal pumps with open impeller and cutters carry out the transfer of biomass within the system, demanding low pressure and high flow. Regarding biomass stirring, the submerged electrically driven medium speed stirrers, largely utilized in the beginning, proved to be relatively expensive in operation and difficult to access for servicing and inspection, especially when mounted inside a digester. Continuously slow rotating stirrers, centrally mounted in the top of the digesters

are considered a better alternative. It requires that the level of biomass in the digester should be correctly adjusted in order to avoid floating layers.

#### *Sand removal*

Animal manure but also other types of biomass contain various amounts of sand and minerals (Ellegard and Kristensen 1997). The presence of few percentage of sand in the biomass flow causes problems, as it is heavily loading the stirring systems, the pumps and the heat exchangers, causing fouling, obstructions, and heavy wear. When accumulated inside the tanks and digesters, the active volume of these will be reduced. The general principles in order to avoid sand problems at the Danish biogas plants are as follows (Ellegard and Kristensen 1997):

- Regularly emptying of pre-storage and storage tanks.
- Establishing of a sufficiently large pre-storage capacity.
- Adequate stirring strategy.
- Adequate placement of the pumping pipe stubs, in order to avoid sand circulation.
- Avoiding highly sand containing biomass.
- Utilization of specially developed methods of sand evacuation from the digesters.

#### *Biomass transport*

The biogas plant is responsible for the transport of animal slurries from the suppliers to the plant and the digested biomass from the plant to the farmers. This task is related to relatively high costs for the biogas plant that can represent up to 1/3 of the operating costs. At the same time it does not involve any costs for the slurry suppliers. The digested biomass is delivered free of charge back to the storage tanks, close to the fields to be spread on, bringing economical benefits for the involved farmers. In order to minimize the transportation costs, it is vital for the plant to be placed optimal, in relation with the slurry density in the area. To make slurry transportation more efficient and lowering the transportation costs means transportation capacities of trucks with 32 m<sup>3</sup> volume tankers and getting into developing pipeline pumping systems as well.

The transport task is well planned, avoiding empty drive and completed with a sustained awareness campaign among farmers about the importance of H<sub>2</sub>O sawing systems at the stables, and of reducing the volume of the transported biomass, by supplying slurry with appropriate dry matter content. Introduction of a bonuspenalty system regarding the dry matter content in the supplied biomass gave positive results at many centralized biogas plants in Denmark.

Fiber separation and concentration of the digested biomass can also contribute to the reduction of transport expenses. Six centralized plants are equipped with installations for fiber separation of the digested biomass, but the results are modest so far. It is estimated that the fiber fraction still contains up to 1/3 of the biogas potential as slowly biodegradable lignocelluloses organic matter. Selling the separated fiber fraction as compost product was not successful and the separation and concentration technologies are still under development, but since 2000 with rapid increasing interest. New innovative technologies now occur in conceptual systems for separating liquid and solid fractions and nutrients in purified fractions, the documented value and treatments costs are not yet verified in all details (Al Seadi and Møller 2003).

#### *Gas recovery from storage tanks*

Experience showed that the digestion process continues inside the storage tanks after the digested biomass is pumped out of the digesters. Up to 15 % of the biogas production can be recovered from the storage tanks if covered with a gas proof membrane. Gas recovery systems are now established at both the new and the old plants in Denmark. The initial one step process becomes a two steps process, where the second step is post-digestion at lower temperature.

## **ORGANISATION AND FINANCING**

### **Ownership and organization**

The organization and the ownership of the Danish centralized co-digestion plants differ from plant to plant according to the local conditions and interest. One of the frequent organization forms is the co-operative company, where the farmers supplying manure to the plant are the owners (nine plants), and in some cases the owners are the farmers and the heat consumers (five plants). Furthermore, three plants are owned and operated by municipalities, two are private foundations, and one plant is a limited company.

Most of the plants are organized as co-operative companies with the farmers who deliver manure to the plants as share members and owners (Ellegaard and Kristensen 1997). The company's board of directors is responsible for managing the plant by a manager and employing the necessary staff. Furthermore, the board is responsible for all economically and legally binding agreements, regarding construction of the plant, feed stock supply, effluent fertilizer distribution, and eventually redistribution, sale of energy, financing, etc. The co-operative company has proved to be an organizational structure that can function with suitable built-in economic and professional incentives to efficiently pursue the aims of the biogas plant.

### **Economy – funding and financing**

Biogas projects demand important investments. Financing is therefore one of the key elements in order to increase the utilization of biogas. The financing schemes must be adapted to this type of investments, with long payback periods, as biogas projects are fitting into the basic supply chain of energy as heat and continuously produced electricity feed into the electricity grid.

The Danish biogas projects are mainly financed by means of index-linked annuity loans, guaranteed by the municipalities, supplemented with subsidies.

Ordinary mortgage loans are used as well, and in increasing extent, due to low bank interest.

The index-linked annuity loans are low-interest loans, which secure the investor against inflation through a revaluation of the unpaid debts with the inflation rate. The maturity is 20 1/2 years. This type of loan proved to be the most suitable for the biogas plants meeting the demands for long maturity, low interest, and low-initial installments. The disadvantages of the loans are that they are raised by ordinary sales of bonds, at the stock exchange at market price, implying a depreciation risk that may induce some uncertainty in the planning phase.

The establishment of all the plants was financed from 20 % to 40 % of the total investment costs by government investments grants. The share of the government grants was higher for the earlier plants, but it has been lowered as the operational stability and the economic results of the plants improved in the last years and from 2003 no grants will be supplied anymore.

The remaining investment costs are financed by indexed mortgage loans, guaranteed by municipalities. Some plants raised bank loans or loans guaranteed by county councils. A number of the early plants were partly financed by traditional mortgage loans, but this type of loans is no longer used in the 1990ies.

Only one centralized plant, Ribe Biogas A/S, the only plant organized as a limited company, controlled its own capital as part of the original plant financing. This financial concept seems to be the strongest way of financing, where the basic financing and responsibility of the boards of directors are the same group of people, supplemented with low rate bank or financial institution loans, and securing of relative high prices of green produced electricity. This pathway of financing will be the major way in the future for new plants.

Considering the Danish case story, the conclusion from the assessment of the results from centralized biogas plants is that it is possible, under favorable conditions, to achieve a balance in the

company economy, without grants for initial investments (Hjort-Gregersen 1999). It is mandatory to have favorable local conditions for selling the biogas and for supplying biomass. A gas yield of at least 35 m<sup>3</sup> per m<sup>3</sup> biomass must be achieved, which means that easy digestible biomass must be added to the slurry, which biogas potential is only of 20–25 m<sup>3</sup> per m<sup>3</sup> biomass (Hjort-Gregersen 1999). The achievement of easy digestible biomass often provides gate fees, contributing to the improvement of plants economy (Hjort-Gregersen 1999).

The biogas plants are still very vulnerable from a commercial point of view, and the actual breakthrough is still uncertain. Relapse is still a very real possibility (Hjort-Gregersen 1999). A major increase in the number of biogas plants implies that the systems must be able to survive economically, mainly on the basis of the animal manure, which is by far their greatest resource. The environmental pressure for sustainable solutions of handling wet organic wastes means that there are many interesting projects in the pipelines in the years to come including co-digestion of manure and organic wastes (Hjort-Gregersen 1999).

A European financing scheme could be established using the positive Danish experience, with long-term index-linked loans, guaranteed by the local or regional authorities, supplemented with national or EU subsidies. The price paid for biogas must correspond to current rules on tax exemption and electricity production subsidies (Holm-Nielsen and Al Seadi 1997).

### **DRIVING FORCES FOR FURTHER ANAEROBIC DIGESTION DEVELOPMENT**

The experience gathered up to now shows that the premises for establishing new biogas plants are generally favorable and the economic risks are considerably reduced compared with the past. There is a potential to establish at least 20–30 co-digestion centralized biogas plants and several farm-scale plants in Denmark in the first decade of the new millennium, and even a much larger number to fulfill the environmental and energy tasks and goals before 2025.

The strengthening of the environmental legislation regarding handling and recycling of organic waste will contribute to enlarge the fundament of organic waste supply to the biogas plants. Some centralized biogas plants are also capable of treating wastewater sewage sludge and household waste, which represent supplementary biomass resources.

Co-digestion of animal manure and approximately 25 % easy digestible biomass (i.e. organic industrial waste) have boosted the biogas production, but have made the centralized co-digestion plants dependent on this type of alternative biomass.

This can limit the future expansion of this type of plants as it is estimated that approximately 70 % of the existing potential of the digestible organic waste is currently utilized. Reaching the biogas development goals of Energy 21 raises the question of finding other sources of alternative biomass within the agricultural sector (DEA, Energy 21 1996). Some steps forward have been made in co-digesting straw, grass, crops waste, agricultural sub-products, etc. This innovative route is led by the German and Austrian biogas sectors, with which the Danish biogas sector has close relationship. The ambitious eightfolding of the overall biogas production until the year 2025, as underlined in the Danish energy plan “Energy 21”, is expected to happen mainly by the contribution of manure-based biogas plants. In order to reach this objective, straightened efforts are to be made in all the biogas-producing sectors to achieve the following:

- Improved economy of the centralized co-digestion plants and independence of supplying highly digestible organic waste.
- Improved technical solutions concerning co-digestion of the organic fraction of source-separated municipal solid waste.
- Further improvement of nutrient efficiency in the digested biomass and reduction of the loss of nutrients.

- Further development and improvement of low-cost farm-scale biogas plants. One of the important elements of the future development of manure-based biogas production in Denmark is the active involvement and motivation of the farmers. The EU-nitrogen directive and the Danish Water Environment Plan II (1998) and new coming EU directives like the animal by-product directive from 10/2002 and the Danish Water Environment Plan III (2003/2004) prescribe a further reduction of the input of nitrogen and phosphorus from animal manure per ha and demand higher utilization rates of nutrients in animal manure. From the farmer's point of view this means an increased need for additional storage capacity and for redistribution of nutrients as new concentrated fertilizers. Separation and volume reduction technologies for digested biomass are at the point of commercial breakthrough and will become an integrated part of the manure-based systems in the near future. The impact of organic farming on the development of manure-based biogas is still an open issue, as well as it is a task for the research sector, the environmentalists to work together, and to find a common ground.

The liberalization of the Danish and European energy market will have an impact on the overall production of renewables. In spite of this, the Danish Government is committed to apply a progressive policy of reaching the political goals in the area of renewable energy systems following the agreements from Rio, Kyoto, Buenos Aires, and other UN agreements, as well as EU commitments.

The public perception and the awareness about the environmental benefits of anaerobic digestion of animal manure and organic wastes are generally positive in Denmark. There is a need for further research work to be carried out, to analyze and quantify the agricultural and environmental effects of biogas production, and the need to include all of them in the national energy policy. To achieve a satisfactory evaluation of centralized biogas plants, a thorough socio-economic analysis has to be carried out. If biogas plants are established on manure-based solely, the deployment of biogas cannot be justified. However, based on long-term economic results, where agricultural benefits and benefits in industry concerning treatment of organic waste are included in the socio-economic analysis, this picture changes, and specifically larger biogas plants are favorable for the society at large (Nielsen et al. 2002). If furthermore the benefits environmental externalities are taken into account, the utilization of biogas plants in the larger scales considered becomes very attractive from the socio-economic point of view.

## **CONCLUSION**

The two main concepts of manure-based biogas plants in Denmark – the large-scale centralized co-digestion plants and the farm-scale plants – represent integrated systems of renewable energy production, manure and organic waste treatment, and nutrient recycling, emphasizing the environmental, energy, and agricultural benefits of anaerobic digestion.

Recognizing the significant contribution of biogas systems for solving a number of environmental problems in the field of agriculture, emission of green house gasses, and organic waste treatment, the Danish Government has supported biogas by creating a favorable framework for its development and implementation such as: appropriate legislative framework, R&D&D programmes, investment grants, and other subsidies. The future development of manure-based biogas systems in Denmark will be influenced by many factors, among which the strengthening of the environmental regulations, the liberalization of the energy market, the organic trends in the farming sector as well as the previously gathered technical, and organizational experience.

## REFERENCES

- Al Seadi, T. (2000) *Danish Centralized Biogas Plants – Plant Descriptions*. Bioenergy Department, University of Southern Denmark, Esbjerg, Denmark.
- Al Seadi, T., Hjort-Gregersen, K. and Holm-Nielsen, J.B. (2000) The impact of the legislative framework in the implementation of manure based centralized co-digestion systems in Denmark. In: *Proceedings of the 1st World Conference on Biomass for Energy and Industry Purposes*. Seville, 5–9 June 2000.
- Al Seadi, T. and Møller, H.B. (2003) Separation of slurry – a potential option for the animal production sector. In: *Proceedings of the European Biogas Workshop “The Future of Biogas in Europe II”*. Esbjerg, 2–4 October.
- Bendixen, H.J. (1999) Hygienic safety – results of scientific investigations in Denmark (Sanitation requirements in Danish biogas plants). In: *Proceedings of IEA Bioenergy Workshop on Hygienic and Environmental Aspects of Anaerobic Digestion: Legislation and Experiences in Europe*. Stuttgart, Hohenheim, 29–31 Marts.
- Danish Energy Agency (1995) *Biogasfællesanlæg fra idé til realitet*. Copenhagen, Denmark (only in Danish).
- Danish Ministry of Environment and Energy (1996) Energy 21, Copenhagen, Denmark. Danish Ministry of Environment and Energy (1998) Waste 21, *Danish Government’s Waste Management Plan 1998–2004*. Copenhagen, Denmark.
- Dansk BioEnergy (1999). *Særnummer af Juni*. BioPress, 8240 Risskov, Denmark (only in Danish).
- Ellegard, L. and Kristensen, E.B. (1997) *Manure Based Biogas Plants in Denmark. Configuration, Dimensioning and Operational Technologies*. BWSC, Denmark.
- Hjort-Gregersen, K. (1998) Danish Farm Scale Biogas Concepts – at the point of commercial breakthrough. In: *Proceedings of the International Conference on Biomass for Energy and Industry*. Würzburg, Germany, 8–11 June.
- Hjort-Gregersen, K. (1999) Centralised biogas plants. Integrated energy production, waste treatment and nutrient redistribution facilities. *Conclusions and Economic Perspectives*. Danish Institute of Agricultural and Fisheries Economics, Copenhagen, Denmark.
- Holm-Nielsen, J.B. and Al Seadi, T. (1997) The future of biogas in Europe. In *the Final Report of Waste for Energy Net II*. The Altener Programme, EC/DG XVII Energy.
- Nielsen, P.S., Salomonsen, K. and Holm-Nielsen, J.B. (1998) *Biogas Policies and Biogas Utilization in Denmark*.
- Nielsen, L.H. *et al.* (2002) *Socio-economic analysis of centralised biogas plants*. Danish Research Institute of Food Economics, report no. 136.





## **7 Management of Anaerobic Digestion processes by Process Analytical Technologies**

Application of anaerobic digestion for treatment of organic by-products and wastes from industries related to food-processing and agriculture is a well known. Biogas plants offer numerous environmental, agricultural, societal, and economic benefits. Due to the fact that biogas production is mainly a closed cycle process it emits pollutants only at a very low level when handled properly. At the same time, the cycle of assimilation and liberation of carbon sources gives an overall positive effect of the release of the greenhouse gases. The process is simultaneously recycling nutrients and producing high-value organic fertiliser with a very reduced pathogenic load, while providing a renewable energy source. The produced biogas is further processed for utilization in the energy or transportation sector. Biogas plants act as an innovative local source of employment.

Biogas plants usually treat a wide range of organic inputs from farm by-products to organic wastes, including municipal organic fractions with varying content of carbon and nitrogen. The heterogeneous biomass feedstock's contribute to process stability and increase the biogas yield. Co-fermentation of animal manure and diverse organic by-products has resulted in high methane yield and is already a common operational practice at medium and large scale biogas plants, i.e., in Denmark, Germany, and Austria.

Increased public awareness concerning environmental issues coupled with the rising costs of fossil fuels has resulted in a boost in capital investments in biogas plants. Hence, an improvement of the technical infrastructures of the plants has been observed. This has further lead to a greater need for operators in order to meet targets stimulated by financial pressures and political framework conditions. The goal is to establish tools that can ensure an enhanced energy yield. Hence, there is an increased demand for fast and efficient monitoring and control tools. This is in contrast to the relatively slow and conventional off-line control schemes, which normally involves time consuming and poorly documented sample extraction, often in conflict with the Theory of Sampling sample preparation and analysis in external control laboratories

Research is constantly being carried out with the prospects of improving the efficiency of the individual stages and of the entire biogas production process, which would lead to an improved energy efficiency and further lead to an insight of the various fermentation phases, intermediates, and products. This has consequently guided the research into a practical and adaptable on-line monitoring and control systems for the anaerobic digestion process.

### **7.1 Anaerobic Digestion process control**

#### **- A literature review and suggestions for what to do next**

Anaerobic digestion is a complex process consisting of several biochemical steps catalyzed by a mixture of microorganisms. The main steps are hydrolysis, acidogenesis, acetogenesis, methanogenesis. The limiting step can be hydrolysis if there is a lot of difficult digestible material, solid and particulate material. On the other hand, when uncomplicated fermentable feed is available, the accumulation of acids can occur and the methanogenesis becomes the rate limiting step (Borjesson and Mattiasson, 2007)

A fine balance must be maintained between these groups of bacteria and processes to secure a productive yield. In the case of process imbalance, an accumulation of hydrogen or other intermediates is likely to occur that would result in inhibition and metabolic shifts (Legin et al, 2003). Process imbalances are normally attributed to three major reasons: hydraulic overloading, organic overloading, and the presence of inhibitory concentrations of toxic materials in the reactor such as ammonia and heavy metals. (Legin et al, 2003). Proper understanding and manipulation of these stages and their respective intermediates or products is the key to suitable monitoring scheme solutions for the biogas plant.

Currently, many biogas plants do not continuously measure and utilize in-depth process data when measured, in rare cases they are only intended to serve as routine monitoring and control parameters, but not for real-time process control. Often, process control in these plants is limited to daily evaluation of easily measurable parameters such as temperature, pH or biogas production rate and volume. Additionally, at regular intervals (monthly) off-line measurements are carried out for total suspended solids, volatile organic acids, and ammonia nitrogen. The number of measurements is often limited due to the high costs of analysis and lack of trained personnel. However, even with recent development of less expensive laboratory analysis such as fast photometric tests for ammonia nitrogen and fatty acids, these measurements cannot give a fast response to facilitate process imbalances during the anaerobic digestion process.

More sophisticated and robust techniques are required for on-line and continuous monitoring of the fermentation. Such innovative solutions would provide a better control tool, increase the stability of the process, and allow the fermentation process to run at more optimal conditions. It would effectively increase economy of the biogas plants.

In order to meet the increasing economic and technical operational targets, optimization of the process capacity can only be done by applying advanced on-line monitoring, which by identifying chemical and physical parameters would give an early warning of the process imbalances and ultimately lead to improvement of the plant efficiency. The monitoring tools must be robust, technically simple, and require little attention and maintenance in order to be of interest for the biogas sector.

The criteria for the system selection should be as follows (Moletta et al., 1994):

- the response time of the sensors measuring chosen parameters should be adequate to the response time of the process phase – measurements in real time
- availability of reliable sensors for the chosen measurements
- minimum number of sensors for a wide range of parameters

Anaerobic digestion can be monitored in different process stages: the substrate quality and its potential through solids, TS (total solids) and/or volatile solids (VS) or chemical oxygen demand (COD) and their degradation during the process; intermediates products formation (VFAs, H<sub>2</sub>, CO, NH<sub>4</sub><sup>+</sup>) and their influence on alkalinity and pH; and final product formation the overall biogas production or CH<sub>4</sub>/CO<sub>2</sub> rate. Typically for biological processes, microbial communities and activities can also be measuring tool.

Temperature and pH measurements are key quantifications and are compulsorily monitored by all biogas plant operators to ensure a suitable environment for the bacteria. These are currently the most widely measured real-time parameters at biogas plants, usually determined using simple

electronic pH meters and temperature sensors embedded in the digester. Maintaining a constant system temperature is of critical importance, because of the strong influence of temperature on the anaerobic digestion process from a kinetic and thermodynamic point of view (Kim et al, 2002). Temperature fluctuations might adversely affect the digestion process especially for plants operating at the thermophile temperature range.

The most important measurement among biogas plants operators, from the production point of view, is the biogas volume. Biogas production measurements can be expressed as overall biogas production or as methane yield, since methane is the valuable product. The yield is usually expressed as Nm<sup>3</sup> biogas/t feed. The methane production might be presented as Nm<sup>3</sup>CH<sub>4</sub>/day or NmL CH<sub>4</sub>/gVS. These measurements only inform as regards the end-product - the produced biogas, without giving any information about the process such as imbalances occurring during the previous biochemical stages. A low recorded biogas or methane yield would only be an indication that the fermentation was disturbed. A perm-selective gas sensor for determining the composition of carbon dioxide/methane mixtures in the range 0-100% is described by (Rego and Mendes, 2004). With a time response shorter than 1.5 min. such a control will make possible to optimize the operating conditions of the methane recovery units, but not the fermentation itself. Measurement of the exact gas composition might give some valuable information about the process stability and efficiency. The ratio between CH<sub>4</sub> and CO<sub>2</sub> is usually stable during the process; it might nevertheless change when the anaerobic fermentation is disturbed. This is because the ratio also depends on other factors such as the substrate quality and composition, process temperature, pH. Therefore, it is better to use methane yield instead of biogas ratio.

In cases, where biogas production is not the main aim of implementing the anaerobic digestion process i.e., in wastewater treatment plants, the organic matter removal is an important indicator. The effectiveness of the process can be expressed as TS, VS, COD, or BOD removal (Perez et al., 2001; Steyer et al., 2002; El-Gohary et al, 1999; Liu et al., 2004). The Biological Oxygen Demand, BOD gives important information about easily biodegradable organic substances, which can be correlated to total biogas production. However, in samples with significant content of organic polymers, polysaccharides, fats, and proteins, underestimation of BOD may occur (Liu et al., 2004).

Organic overloading can be defined as an input of COD that exceed the degradation capacity of the microorganisms (Moletta et al., 1994). This parameter can also be measured to ensure effective substrate feeding of the reactor. Volatile fatty acids (VFAs) are intermediates, which may accumulate during the fermentation process; thus, they become the first indicator of anaerobic digestion imbalances (Punal et al., 2003). VFA measurements can be a very useful tool for process monitoring both in low and high buffered systems, whereas pH and alkalinity can be only applied to the first type of the process. Volatile fatty acids seem to be the best parameter for indicating any of the process instability since the concentration of these compounds gives a signal on the state of the internal environment and progress of the digestion process. Each individual component of the VFAs can give valuable information and become an indicator for early warning of process imbalances.

Different researchers suggest diverse choice of acids as an indicator of stress level in the event of a failure in the anaerobic digestion of biomass: iso-butyric and iso-valeric was proposed by (Hill and Bolte, 1989), whereas (Ahring, 1995) recommended n-butyric and iso-butyric. Propionic acid may also be process indicator. During overloading, when the partial pressure of hydrogen increases, the degradation of propionate is affected before other VFAs (Boe, 2006). Hansson et al (2003) proposed the use of propionate as a process indicator, and also the ratio of propionic to acetic acid

was found to be viable and sensitive indicator for anaerobic digestion instability (Marchaim and Krause, 1993).

VFA concentration is an excellent parameter for early indication of organic overloading and it is easily measured by GC or HPLC after all particulates are removed from the sample. (Pind et al., 2003) presented a novel in-situ filtration technique for animal slurry or manure. An on-line headspace gas chromatographic method was described by (Boe et al., 2005). The advantage of headspace measurements is that there is no need for sample filtration (filter parts might be sensitive for fouling in the manure sample). The innovative system was well described in (Boe, 2006).

A titrimetric method was proposed by (Feitkenhauer et al, 2001), who described an on-line titration of volatile fatty acids, which could be successfully implemented using commercially available components for pH value measurement/titration and volume metering together with a purpose-designed measurement cell, which can be used with relative simplicity. The proposed method is also applicable without biomass separation (filtration) before the titration. However the sampling has to be in accordance with the TOS, to minimise the sampling error, which in many cases will be difficult to apply in this context.

Besides VFAs, the measurement of alkalinity might also prove useful in the on-line monitoring of the fermentation process. A correlation between VFA accumulation and alkalinity levels was presented by (Hawkes et al., 1994), who suggested that the monitoring of the bicarbonate alkalinity would serve as an effective tool for early warning of organic overloading. Increased concentration of VFA will consume alkalinity, before changes of pH will be noticeable. It is an alternative to pH measurements for well buffered systems (Lahav and Morgan, 2004). Some researchers suggest measuring the ratio of volatile fatty acids to bicarbonate alkalinity (VFA/ALK). The lower the ratio, the better is the balance of oxygenic and methanogenic bacteria (Barampouti et al., 2005).

The hydrogen concentration observed during the fermentation stages might also be important indicator during the biogas production process. High hydrogen concentration might inhibit VFA degradation (Boe, 2006), whereas low concentrations can indicate under-loading (Rodriguez et al., 2006). Due to the fact that hydrogen is formed in the liquid phase, its concentration depends on liquid-gas transfer. It was found (Guwy et al., 1997) that H<sub>2</sub> levels in biogas cannot be used as a control parameter. Liquid phase measurements of the microbial environment are more representative, moreover the concentration of dissolved hydrogen in the bioreactor influences the stability and efficiency of the anaerobic digestion. (Cord-Ruwisch et al., 1997) describes continuous dissolved hydrogen measurement, based on trace reduction gas analysis. A relation between the dissolved H<sub>2</sub> and the digester loading rate was found.

Other gaseous factors could also influence the biochemical processes, (Hickey and Switzenbaum, 1990) indicated that gaseous carbon monoxide was indirectly related to the acetate and inversely related to methane concentration. So, CO might be an internal control parameter in acetate metabolism of methanogens. However, documentation for further research with application of CO as a process indicator, which would verify that theory, has not been found.

Still other parameters that might be considered in developing biogas process monitoring schemes include ammonium: although considered a nutrient, the compound in its un-dissociated form 'free ammonia' can become toxic and inhibitory to the fermentation process at some concentrations depending on the pH (Koster, 1986) and concentrations could therefore be monitored. Likewise,

depending on pH and alkalinity conditions of the system the concentrations of hydrogen sulphide can exhibit a similar effect. (O'Flaherty et al, 1998) describes hydrogen sulphide toxicity threshold alkalinity values from 200mg/l to 500mg/l.

Growing number of biogas plants in Europe have shown an increased interest in on-line monitoring and control, this in turn has led to a great deal of research being carried out in the field of instrumentation, control, and automation of anaerobic processes. The main aspiration of these current investigations is faced with the practical and preferable non-expensive optimization of the partial stages in the biogas plant such as the improvement of biogas production. However, problems encountered in anaerobic digestion systems are usually complex and multi-faceted, for example dealing with biogas composition, reducing CO<sub>2</sub> and H<sub>2</sub>S fractions while increasing CH<sub>4</sub>, coupled with increasing biogas production volume.

Appropriate process information regarding the anaerobic digester process; biomass, substrates, intermediates, digestate, and nutrients not only facilitates making better control decisions but also optimizes productivity in turn leading to decreased variability and potentially improved product, biogas quality. Utilization of diverse substrates and demand for high biogas yields requires highly efficient process optimization. Several on-line techniques are well described in (Vanrolleghem and Lee, 2003; Steyer et al, 2006).

On-line measurement of intermediates in the solid-liquid phase can give a variety of information. The liquid component from the anaerobic digestion process is a very complex media; hence, it increased the difficulty in establishing a control scheme for the intermediates used as an indicator. As described earlier the measurement of VFAs has proven to be a suitable indicator for process instability.

### **7.1.1 Spectroscopy seems to hold the key to a practical and reliable on-line measurement and control of intermediates i.e. VFAs in the complex anaerobic digestion process**

The use of solid state nuclear magnetic resonance (NMR) spectroscopy for the investigation of organic matter transformations during the composting of solid waste was reported by (Knicker, 2004), and it could possibly be studied further for adaptation into anaerobic digestion systems. Of the established methods of spectroscopy, the application of infrared spectroscopy offers powerful possibilities in fermentation monitoring by the measurement of different types of interatomic bond vibrations at different frequencies. The use of Mid and Near infrared spectroscopic methods in on-line measurement of anaerobic digestion processes is the theme of many ongoing research projects.

The use of Near Infrared Spectroscopy (NIR) tools for real-time process monitoring seems to be the most promising solution as it is rapid and non-invasive. "The absorption of energy is caused by overtones and combination bands from fundamental infrared vibrations in the -CH, -NH and -OH molecular groups and it is therefore related to the chemical or physical composition of the sample (Nordberg et al, 2000. This is what makes application of this spectral range particularly useful for multi constituent media analysis such as in biogas systems. Furthermore, it requires no addition of chemicals and once calibrated and validated by help of multivariate data analysis, it involves little maintenance. NIR method can be applied as a general process indicator over a long time, it can indicate process imbalances, and it can be used for control strategies (Hansson et al, 2003).). The fibre optic NIR probe was able to monitor microbial growth with a response of about 1 minute (Nordberg et al, 2000), propionate concentration (Hansson et al, 2003); biomass, glucose, lactic and

acetic acids (Tosi et al, 2003). Utilization of NIR to monitor important variables of methanogen density and acetate concentration simultaneously in the anaerobic digestion process was discussed by Zhang et al (2001).

Mid Infrared spectroscopy has exhibited immense potential in the real time monitoring of multiple analytes in the anaerobic digestion process. Roychoudhury, Harvey, and McNeil (2006) discussed the potentials of using mid infrared spectroscopy (MIRS) for real-time bioprocess monitoring over the rival spectroscopy method Near Infrared Spectroscopy (NIRS). The investigation put forward that most industrial processes are fed-batch bioprocesses, which usually involve the control of one or more nutrients at very low, limiting levels that are typical of chemostat continuous culture systems. Although the advantages, i.e., broader wavelength of MIR of controlling anaerobic digestion system it still faces limitations and requires further studies. This is an area, where the much stronger absorbance in the MIR spectra may provide more useful information than the correspondingly weaker NIR absorbance. A combination of MIR and NIR measurements seems to be a stronger monitoring tool for on-line fermentation processes (Roychoudhury, 2006). Although the possibilities of the application of Near Infrared spectroscopy seems very promising for the on-line monitoring of the very complex fermentation stages, more research is required to establish greater confidence and promote the use of this method. This is because the effective implementation of the NIR in monitoring anaerobic digesters treating liquid and solid bioslurries still demonstrates several challenges (Zhang et al 2001). In the following chapters the studies carried out in this thesis will go into depth in the on-line monitoring and implementation stages of process analytical technologies. Detailed descriptions are provided on how the tools, sensors, and system approach became operational.

## 7.2 Process Analytical Technologies – including NIR sensor technology as a PAT tool for on-line anaerobic digestion monitoring and process control

Efficient monitoring and control of the fermentation processes including anaerobic digestion processes are necessary in order to enhance their performance. The substrates in anaerobic co-digestion processes are very heterogeneous. The task of monitoring and controlling the biological processes is to stabilize and optimize the production of biogas. Another important factor is to increase the production capacity and speed without running any risk of process instability or inhibition and finally, to enhance productivity. By applying the principles of Process Analytical Technology (PAT), the above issues can be addressed effectively (Junker et al. 2006). Some photos from the ongoing full-scale trials are shown in fig. 7.1.



**Fig. 7.1: Full scale PAT studies managed during 2007. Trials and tests were conducted at LinkoGas a.m.b.a., Rødding, Denmark. PAT tools for on-line monitoring facilities were mounted at a recurrent loop integrated with fermentor no. 3 volume 2400 m<sup>3</sup>. Testing of various NIR probes of transflexive and reflexion types was conducted. Lower right photo shows the sampling point for chemical reference analysis.**

## **Process Analytical Technology**

To facilitate continuous process improvement and optimization of productivity and product quality, process data can be monitored and analyzed at whatever resolution found necessary. Process Analytical Technology (PAT), represents the right measurement program and technologies for achieving these goals. The American Food and Drug Administration (FDA) describe process understanding in their PAT-initiative. This is essentially a recompilation of the earlier Process Analytical Chemistry (PAC) concept (Mortensen, P.P., 2006). The FDA descriptions of the PAT-Initiative from 2005 define PAT as:

“A process is generally considered well understood when (1) all critical sources of variability are identified and explained; (2) variability is managed by the process; and (3) product quality attributes can be accurately and reliably predicted over the design space established for materials used, process parameters, manufacturing, environmental, and other conditions. Although retrospective process capability data are indicative of a state of control, these alone may be insufficient to gauge or communicate process understanding” (FDA - PAT Initiative, 2005).

PAT is primarily directed towards the pharmaceutical industry, but the initiative is also covered by other industries. In 2004 the FDA completed a “Guidance for Industry”, where PAT was defined as: a system for designing, analyzing, and controlling manufacturing through timely measurements during processing of critical quality and performance parameters of raw and process intermediates. The goal is to monitor and control the process on-line as early as possible in the process and in real time at strategically selected process locations with steps that ensure the quality of the final product. The term Analytical Technology in PAT refers to analytical chemical, physical, microbiological, mathematical, data and risk analysis conducted in an integrated manner. The term Quality of a product has the meaning of the final quality of various industrial processes, it can either be the concentration, pureness, strength, or similar of the processed products. “Quality cannot be tested into products; it should be built-in or it should be by design” (FDA PAT guidance for industry, 2005). Product quality and/or quantity have to be optimization during the ongoing process.

Numerous technologies can be applied in a PAT measuring programs for process understanding and controlling. The technologies can be categorized in four major areas.

1. Technologies that imply use of Process Analytical Technology or Process Analytical Chemistry
2. Technologies for monitoring and control of the process and end products
3. Technologies for continuous improvement of gained process knowledge
4. Technologies for acquisition and analysis of multivariate data

(Junker and Wang 2006; FDA - PAT Guidance, 2005)

The benefits that can be gained from a higher level of process understanding and optimized process control is one of the results of introducing on-line PAT tools. A deeper understanding into the dynamics of the process often generates new information that can significantly help to optimize the process. Numerous examples exist in literature and in different industrial application areas (Bakeev, 2005).

Traditionally, monitoring and quality control of production processes has been based on centralized laboratory approach. Samples are collected from a process stream and send to the analysis



laboratory. There, the sub-sampling, sample preparation, and chemical analysis are carried out. Often in an optimized manner, allowing multiple samples to be analyzed in the same run. The time span from the primary sampling was taken at the process stream until the analytical result had been produced and approved could span from several hours to days depending on the laboratory infrastructure and routine (Mortensen, P.P. 2006).

This centralized strategy is regarded as almost useless in terms of process control for biological processes, depending on the time constant related to a given process. For instance, a fast changing process would require an even shorter combined analysis time, if the analytical result was to be used as an efficient process regulating tool.

Schematically, the pathways for the centralized laboratory strategy and the process analytical technology strategies from sampling until a decision can be made based on the analytical results. This is illustrated in fig. 7.2 (Mortensen, 2006).

#### Centralized Laboratory Strategy

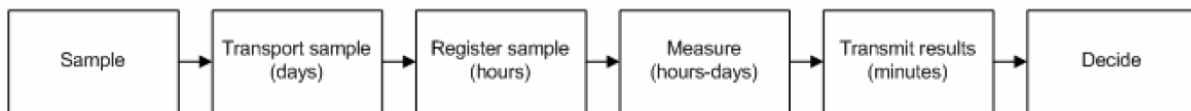

#### Process Analytical Strategy

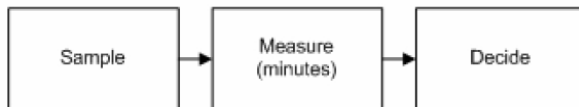

**Figure 7.2. Comparison of analytical strategies for process monitoring**

Adapted from (Mortensen 2006)

It is clear that the analytical strategy has to be changed from the centralized laboratory strategy to the process analytical strategy, if the plant operator wants to benefit from the analytical results and use them as true process regulation parameters instead of just ‘delayed’ quality control parameters. In fact, the quality control task is moving from the reference laboratory and into the process line itself. This can be considered as a change of paradigm (Junker and Wang 2006), initiated two decades ago by CPAC, the Seattle based Center of Process Analytical Chemistry at the University of Washington (McLennan and Kowalski, 1995)

Modern fast computers, data analysis programs and process analytical equipment like fiber optics and spectrophotometers at cost efficient levels today allow for at-line and on-line techniques to enter the market for process monitoring and control in various industries also outside the pharmaceutical production sector. The Process Analytical Chemistry (PAC), approach offers many advantages over traditional process characterization. It is essential that the plant operator can read the state of the process continuously and launch correcting countermeasures as soon as possible. It is important to move this step forward in the understanding process and not to rely only on accumulated human experience.

PAC is based on three fundamental disciplines as illustrated in figure 7.3.

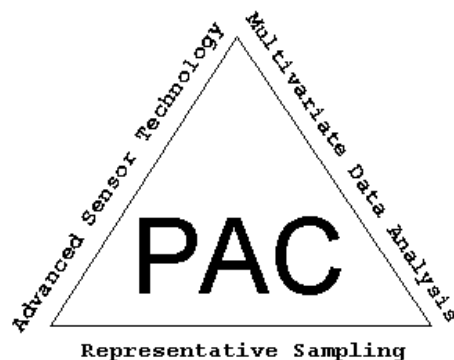

**Figure 7.3. Fundamental disciplines of Process Analytical Chemistry (PAC)**

**Adapted from (Madsen 2007)**

The three fundamental disciplines are *representative sampling*, *process sensor technology*, and *multivariate data analysis*.

At first sight, PAT and PAC look much the same, and one could wonder why it is necessary to extent PAC to contain more information in its new form, PAT. PAC has been a part of chemical science for almost a century. PAT differs from PAC in the sense that it also provides guidance and tools for quality assurance and risk management. The PAT concept is extended to involve a larger part of the natural line of management in modern manufacturing processes, whereas the PAC concept is solely technology driven. Therefore, it was necessary to take process monitoring and management to a new level of awareness and operability (Mortensen, P.P., 2006). This development can be appreciated by studying the development over ten years between the two main PAC/PAT sources – “Process Analytical Chemistry”, (McLennan and Kowalski, 1995) and “Process Analytical Technology” (Bakeev, 2005).

When PAT-infrastructure can be implemented in all process and manufacturing industries it will mean a revolution of process optimizing and control and increased quality products. This has not happened yet due to the fact that there are numerous difficulties involved. PAT implementation is multidisciplinary in its approach; fundamental understanding of correct sampling is one of the basic pathways that as of yet is not fully understood in various industries. Other central challenges for the successful development of on-line process monitoring of advanced biological processes involve the right choices of sensor technologies, reference analysis, multivariate data analysis, spanning of data and model development and maintenance.

This thesis provides a glimpse into the various aspects and attempts to offer some answers into the multi-disciplinary PAT aspects of on-line monitoring of fermentation processes. The model process used has been the anaerobic digestion process. The incentive for a process analytical strategy, whether it is based upon PAC or PAT, is to increase and stabilize production yields by minimizing all types of variations and keep the process within optimal operation conditions at all times. The process analytical approach will reduce the need for accurately determined analytical results from quality control laboratories, but it will never eliminate the need for those analyses completely. In

the future there will be need for more test set back up and PAT quality control and adjustments. The two analytical strategies should in fact be viewed as *complementary strategies*.

### 7.3 Sampling issues in the context of AD process control

Fermentation processes at full scale biogas plants are sensitive to sudden changes in feedstock composition that cause significant variability in the process conditions i.e., organic overloading. Today, fermentation process control is usually achieved through manual sample extraction with off-line analysis of a few key process parameters (Nordberg et al., 2000; Ahring et al., 1995).

Even though time-constants involved in anaerobic digestion (AD) do not have a critically short time response - average hydraulic retention time of feedstock in a semi-continuously digestion system is in the order of 10 to 25 days - there is, nevertheless, a desire for implementation of on-line process monitoring technologies, of an inexpensive, robust type (Hjort-Gregersen et al., 2005; Al Seadi, 2005; Holm-Nielsen et al., 2007).

Any process analytical technology (PAT) is critically dependent on the representativity of the signals obtained from on-line or in-line probes or sensors in pipelines / reactor tanks as well as representativity of the samples analysed *in toto* for calibration and validation. For example, what is the relationship between a sensor or probe's field-of-view (FOV), a few cm<sup>2</sup> or mm<sup>2</sup> in relation to the entire cross-section of a transportation pipeline or the entire reactor volume of 100 or 1000's of m<sup>3</sup> in question? What are considered in the Theory of Sampling (TOS) as "incorrect sampling procedures" that often occur in the AD process? These will always result in biased, non-representative and hence, unreliable analytical results (Gy, 1996; Pitard, 1993; Smith, 2001; Petersen et al., 2004; 2005; Esbensen et al. 2007). Therefore, all traditional sampling procedures involved in the general AD process flow are carefully evaluated in the present study in light of TOS. The specific sampling errors are estimated, where needed, in order to put these previously largely neglected sampling issues on strict quantitative guidelines.

Sampling is a critical component in any analytical procedure and must always ensure representativity of the primary, secondary, tertiary sampling steps. Total sampling errors can typically be in the order of 100+ times the specific analytical error. "Incorrect sampling" always results in non-representative samples, because of an uncontrollable bias even though all subsequent steps have been performed in a reproducible fashion. (Gy, 1996; Pitard, 1993; Smith, 2001; Petersen et al., 2005; Esbensen et al. 2007).

Animal manure forms a highly complex and heterogeneous suspension with a hydraulically highly significant proportion of solids, "dry matter" (3–12%): straw, grass, undigested ligno-cellulosic fiber particles, besides not-yet digested macromolecule aggregates such as starch, sugars and proteins. Therefore, such suspensions are always prone to segregation on several scales, which sets in immediately after agitation has been terminated. Sampling from such systems will consequently introduce a significant sampling bias if not properly counteracted, (Petersen et al., 2005, Petersen & Esbensen 2006; Esbensen et al 2007).

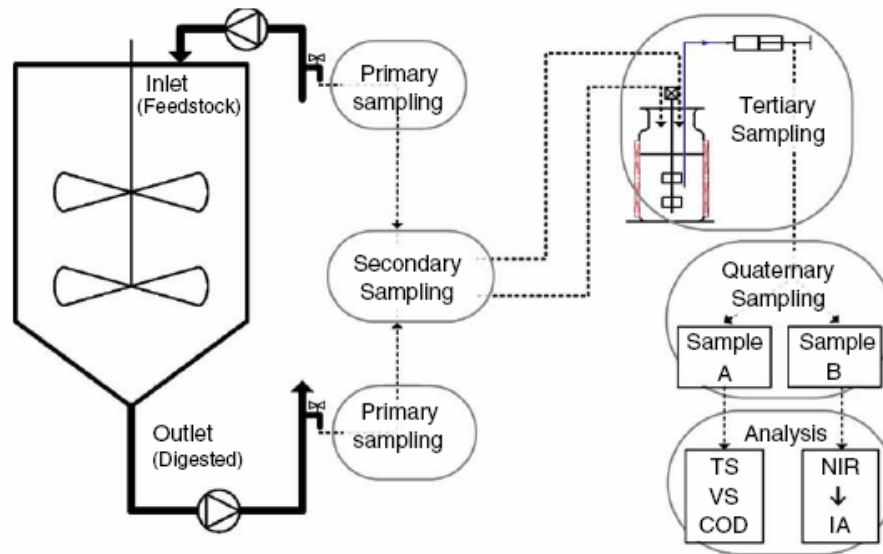
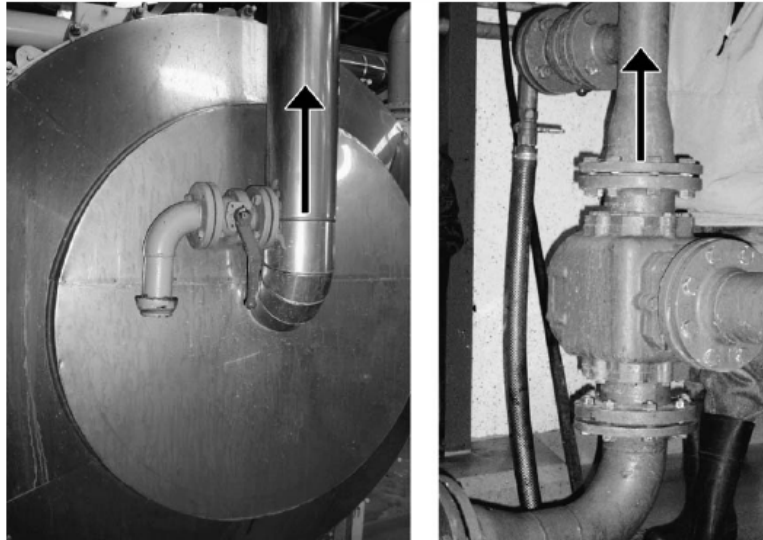

Fig. 7.4. Schematic illustration of the necessary sampling hierarchy for the AD process, including primary sampling at the full-scale biogas plant, secondary sampling preparing samples for fermentation trials, tertiary sampling from laboratory fermentation reactor and quaternary sampling associated with analysis. Adapted from (Holm-Nielsen et al. 2006)

Primary sampling, representative sampling at the full-scale biogas plant is the most important and the most difficult issue of all sampling issues. The feedstock, in one of the monitored biogas plants, in terms of total solid contents is composed of approximately 80 % pig and cattle manure with an addition of 20 % industrial organic waste from Danish food processing plants, primarily from slaughterhouses. All feedstock's of this origin utilized for biogas production are very heterogeneous by nature and constitute a relevant setting for evaluating all issues involved, when sampling heterogeneous materials in general. There are absolutely no shortcuts available regarding the representative process – and raw material / product sampling in the AD regimen. This thesis welcomes this state of affairs, as it allows for a general didactic presentation of the merits available for informed application of the Theory of Sampling (TOS).

During the research presented in **Paper 1**, suitable primary sampling sites were identified for both feedstock and final digested biomass sampling. Significant gravitational segregation always occurs in horizontal pipelines with a higher concentration of solid material along the bottom of the pipe flow. Therefore, it was decided to sample from a vertical pipeline through side-valves: upward flow greatly facilitates mixing due to turbulence, gravity now acting to boost the effectiveness of mixing. The pre-mixed feedstocks were sampled before addition to the full-scale fermentation reactor (Fig. 7.5, left), while digested biomass was sampled directly at the outlet pipeline immediately after the fermentation reactor (Fig. 7.5, right). It is not only important to point-sample heterogeneous material in well-mixed up-flow pipelines - it is equally important to employ extensive time-averaging *composite sampling* schemes, tuned to the specific situation(s). Thus, primary sampling took place by spanning eight buckets, each with a volume of 10 L of biomass with 3-min intervals in the continuous pumping.



**Fig. 7.5. Primary sampling locations for feedstock and digestate. Left: outflow from heat-exchanger immediately before inlet to CST reactor. Right: sampling of digested biomass at the CST reactor outlet. Note sampling in vertical upward flow. Adapted from (Holm-Nielsen et al. 2006)**

To overcome the difficulties for the TOS-correct reactor sampling, a recurrent loop sampling concept can be introduced, essentially transforming the three-dimensional bioreactor sampling issue into a one-dimensional pipeline sampling situation (Esbensen, *pers. com.* see also Petersen et al., 2004; 2005) as illustrated in Fig. 7.6.

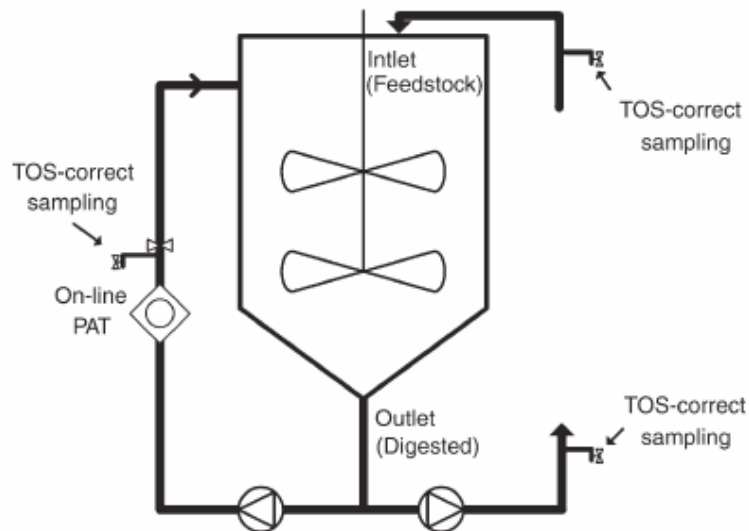

**Fig. 7.6. On-line PAT measurement and TOS-sampling concept in a full-scale bioreactor setting. Adapted from (Holm-Nielsen et al. 2006)**

To be fully representative, a vertical recurrent loop concept should be implemented. From such an external loop, pumping from the bottom of the reactor to the top, a full cross-section of the upward flow could be achieved as a composite sample using as many increments as necessary by a heterogeneity study (Petersen et al., 2005). Such a set-up would ensure an optimal ability to represent the entire volume of the fermenter. Structural correctness means that all parts of the lot material have an equal probability of being selected in the sampling procedure. This can obviously

never be the case when samples are extracted from the side of a bioreactor (Mortensen and Bro, 2006; Petersen 2005; Petersen et al., 2005).

Bioslurries in AD and other fermentation processes are almost always pumped in pipe-lines, fed in semi-continuously or continuously into the bioreactor systems and, further on, to the post-treatment technologies. On-line PAT measurements in pipe-line systems at fermentation plants have huge importance and potential. This is especially important for heterogeneous slurries with a tendency to segregate. For bio-slurries with a significant total solid content, this could easily lead to measurements with highly excessive sampling errors, if measured at-line in a static manner. A very important factor regarding the accuracy of measurement concerns the optimal analytical sample volume.

The flow-through cell: Transflexive Embedded Near Infra-Red Sensor (TENIRS) used in the studies, **Paper 2 and 3**, can work as a closed loop on the entire sample volumes of 1L or directly attached on-line to fermenter. The TENIRS is illustrated in Fig. 7.7. The working condition with this equipment is that the total reactor volume is pumped through a recurrent loop through the measurement cell. For closed loop (1 L) applications this allows a high degree of representativity of the measured analytes because this is essentially a very extensive composite sampling configuration. The TENIRS flow-through cell can also be applied as an external recurrent loop directly coupled to lab scale biofermenters volumes of 5L, **Paper 3**, or attached to a 150L fermenter (**Paper 4, in prep.**). The principles can be up-scaled to full-scale bioreactor systems (*in preparation*).

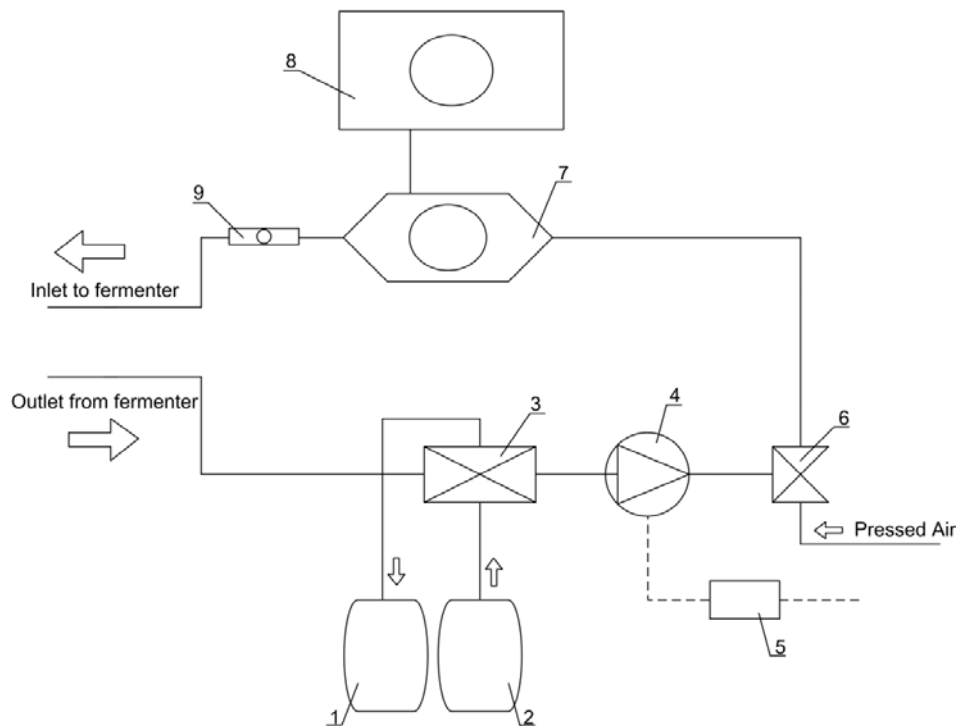

**Fig. 7.7. Recurrent measuring loop connected to fermentor: (1) Outlet cleaning water; (2) Inlet cleaning water; (3) Multiway valve; (4) Impeller pump; (5) Frequency controller; (6) Air valve, for drying after cleaning; (7) NIR flow-through cell; (8) Zeiss Corona NIR 45 instrument; (9) Sampling device. (Holm-Nielsen et al. 2007)**

To obtain primary samples in agreement with TOS, a pilot device facilitating sampling from the on-line stream flowing through the TENIRS loop was developed and implemented directly after the measuring cell. By applying this configuration, samples could be obtained from a one dimensional pipeline flow of the biomass corresponding well to the full three dimensional fermenter volume because of continuous extensive recirculation. The sampling device (fig. 7.8) consisted of a 10 mL bottle fitted in such a manner that increments from the loop could be extracted via a “sliding door” valve mechanism fitted at the bottom. Ten increments were taken resulting in a primary 100 ml bio-slurry sample, insuring an effective composite sample (Pitard, 1993; Gy, 1998; Petersen, 2005; Mortensen, 2006).

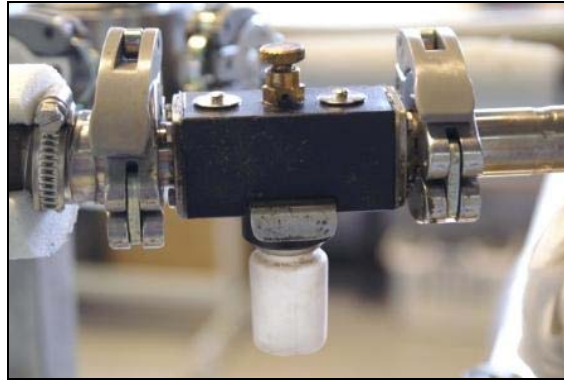

**Fig. 7.8. Prototype sampling device. 10 increments each of 10 ml were sampled during a period of 10 minutes – an effective composite sample for chemical reference analysis. Adapted from (Holm-Nielsen et al. 2007)**

This loop sampling was not in the vertical configuration, as the TENIRS system only allowed horizontal modifications. This configuration is not completely in accordance with TOS as an instantaneous total cross section of the flow in the pipeline is not completely ensured. As a result the samples were perhaps slightly biased. Yet, this is a major step in the direction for the development of a fully correct closed recurrent fermenter loop system and was used with this stipulation.

*To summarize this section* of how to be in accordance with TOS-correct sampling we have to be aware of few principles of sampling in practice. It can be expressed as a TOS toolbox of unit operations to respect the principles of correct sampling under all kind of harsh conditions in nature, pollution areas, at any kind of sampling situations as like in these studies in 3-D fermenter situations of very heterogeneous bioslurry systems, or many diversified places in industries.

#### **Sampling unit operations:**

In order to perform correct sampling in practice, always respecting the principles of TOS, we only have to know about seven *basic* sampling unit operations (SUO) pertaining to normal sampling of 0-D lots, read detail in (Petersen et al., 2005);

1. Structurally correct sampling is the *only* safeguard against sampling bias
2. Heterogeneity characterization of 0-D lots
3. Homogenization, mixing, blending
4. Composite sampling
5. Representative mass reduction
6. Particle size reduction (comminution or crushing)
7. Lot dimensionality transformation (3D or 2D → 1-D or 0-D)

Everyone can make correct samples by utilizing these tools. It only takes a little work to be introduced to these principles, which will yield a generous return from significantly more reliable analytical results. In the biofermentation systems studies throughout this thesis there have mainly been focusing on full utilization of principles 1.- 4 and the very important no. 7. Lot dimensionality transformation from 3-D like the LinkoGas 2400 m<sup>3</sup> fermenter into the recurrent loop 1-D sampling dimensionality. Representativeness can only be ensured by performing structurally correct sampling. Representative samples result only from performing a representative sampling process correctly. The focus should consequently always be on the primary and following steps of the sampling process, (Petersen and Esbensen, 2005).

#### **7.4 Multivariate data analysis – Chemometrics as the final tool for process AD control**

Multivariate data analysis is the important third stage of the process analytical technology PAC-triangle. Chemometric data analysis is explorative data analysis, or as described by The International Chemometric Society (ICS, 2006): “Chemometrics is the science of relating measurements made on a chemical system or process to the state of system via application of appropriate mathematical or statistical methods”.

Various methods of multivariate data analysis exist in chemometrics. These can be divided into three main types; a) data description, b) discrimination and classification, and c) regression and prediction (Esbensen, 2001). This main focus of this thesis is on multivariate regression and the prediction of process parameters by processing Near Infrared spectra and other multivariate data from Images Analysis, Electronic Tongue or Acoustic data sets of the heterogeneous bioslurry. The later data sets have been only initially investigated here while NIR data sets are analysed in detail in several of the present studies.

Chemometric data analysis gives an overview of the state of the chemical and/or biological processes based on analytical measurements. The idea of chemometrics is to let the process or the data structures unfold their relations themselves. From Chemometric data analysis it is possible to decrease the required number of parameters (components) in order to describe the investigated phenomena, even though multivariate data analysis often starts with a much higher number of variables (Esbensen, 2001).

Chemometric methods are almost always *multivariate*, based on modelling and visualizing covariance structures among a high number of initial variables. This means that chemometric data analysis is very effective for analyzing complex data structures and in particular to analyze complex processes, i.e., as an advanced and necessary tool in the context of PAC and PAT.

#### **Modelling of multivariate data and data processing**

Principal Component Analysis (PCA) forms the original platform of chemometrics and is very useful in relation to two of the basic cornerstones in the multivariate data analysis; data exploration and classification. PCA only works on a X-data matrix. However, in this study it was necessary to probe one layer deeper. In the context of PAC/PAT multivariate data structures also a Y-data matrix is introduced, containing the “reference values”.

The Partial Least Squares (PLS) regression was first designed and described in the late seventies and early eighties (Jöreskog and Wold, 1981). PLS regression is a powerful technique, the third



cornerstone in the science of chemometrics, utilized for regression and prediction. PLS data analysis of the X-matrix is *guided* by the information in the Y-data matrix (Esbensen 2001, Martens & Næs (1996). The PLS regression objective is to predict the dependent Y-variables from the independent X-variables. The method allows an active influence of the Y-matrix in the decomposition of the X-data set, by only seeking information in the part of X-matrix that is *correlated* to the modelling or description of Y-variables.

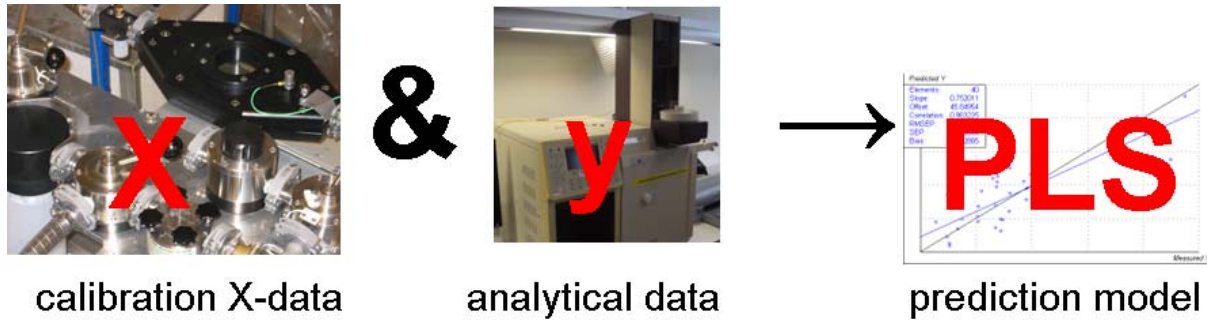
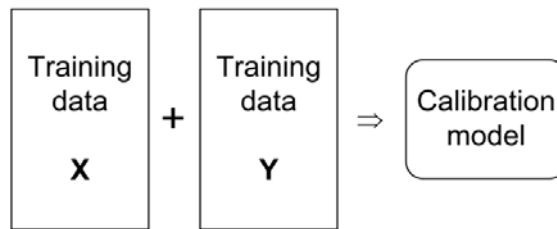

Figure 7.9 Principles behind creation of a multivariate calibration models

In *multivariate calibration and validation* a large number of X-variables are used to correlate to a given reference (chemical or physical) variable-Y. Examples from these studies X: NIR spectra; Y: chemical reference variables. Partial Least Squares (PLS) regression was used with the scope to predict future Y-data directly from X-data. PLS-Regression (PLS-R) consists of three stages: model training - calibration, validation, and prediction (Martens and Næs, 1991; Esbensen, 2001).

**Step 1 (model training):**



**Step 2 (prediction of new Y-values):**

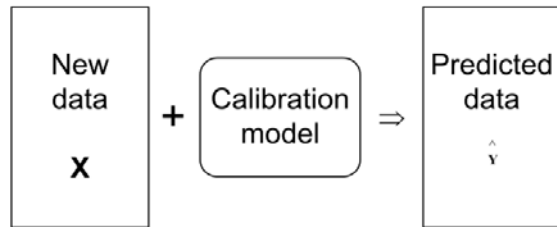

Figure 7.10. Steps in PSL-regression. During step 1 a multivariate calibration model is generated. In step 2 the calibration model from step 1 is applied on new X-data in order to predict the corresponding *unknown* y-data Adapted from (Petersen, 2005)

## Validation of data structures

The purpose of validation is to provide an assessment of the overall performance characteristics of the calibration model f.ex. with respect to prediction and classification. Validation will show how well the model is able to operate with variability (sampling, analysis, model) based on “new X-data”. Validation will also provide critical information on the optimal number of components to be included in the final model (Esbensen, 2001, Petersen, 2005).

Three validation methods exist in the field of chemometrics: 1) Leverage corrected validation, this is the weakest validation method, not utilised in research and development work; 2) Cross Validation – maybe the most commonly used validation method, due to argumentation of “too low numbers of samples”, when the economy of laboratory time and/or the general time available for research; such issues will keep the numbers of samples low. The cross validation method means that one or more samples are left out of the model calibration set, and secondly in an iterative fashion utilise these samples in the same fashion as test samples. 3) Test set validation is definitely the strongest method of testing a model data structure for its validity (Esbensen, 2001). Test set validation consists of extracting a completely independent new set of samples; this new data set is used for validation of the model only. Often the test set of samples is managed in a new time series of trials or in a parallel set of test fermenters.

Finding the optimal model complexity is essential in PLS regression. This is most often carried out by finding the lowest residual validation variance, the minimum prediction error; this can be seen as the Root Mean Square Error of Prediction (RMSEP):

$$\text{RMSEP} = \sqrt{\frac{\sum (y_{\text{predicted}} - y_{\text{reference}})^2}{n}}$$

where  $y_{\text{predicted}}$  is the predicted  $y$  in the validation, and  $y_{\text{reference}}$  is the true validation value.

## Multivariate Calibration and Validation of on-line NIR spectra

Test set validation has a real advantage in some of the present studies where trials were performed in three parallel, independent fermenter systems as described in **Paper 3**. The results from the test set validation are much more reliable than any internally re-sampling of the training data set alone that would take place where cross validation would be used.

The data obtained from the TENIRS system was modelled using The UNSCRAMBLER software (CAMO Process ASA, Norway, ver. 9.5). Multivariate calibrations using Partial Least Square regression (PLS-1) were performed for quantitative determination of glycerol and total-VFA as well as for the individual acids acetic, propionic, iso-butyric, butyric, iso-valeric, and valeric acids. For each chemical component a separate model was set up (see examples below). In all cases the models were evaluated by a comprehensive test set validation applying fermentation no. 1 and 3 as the calibration set respectively and fermenter no. 2 as the test set.

All fatty acids were modelled by PLS-1 analysis in UNSCRAMBLER in the same fashion as the model for glycerol, see paper 3. As an example, a total VFA model is shown below. This parameter lies at the heart of the matter for documenting the strength of the application possibilities of NIR measurements as a PAT tool for monitoring anaerobic digestion process behaviour.

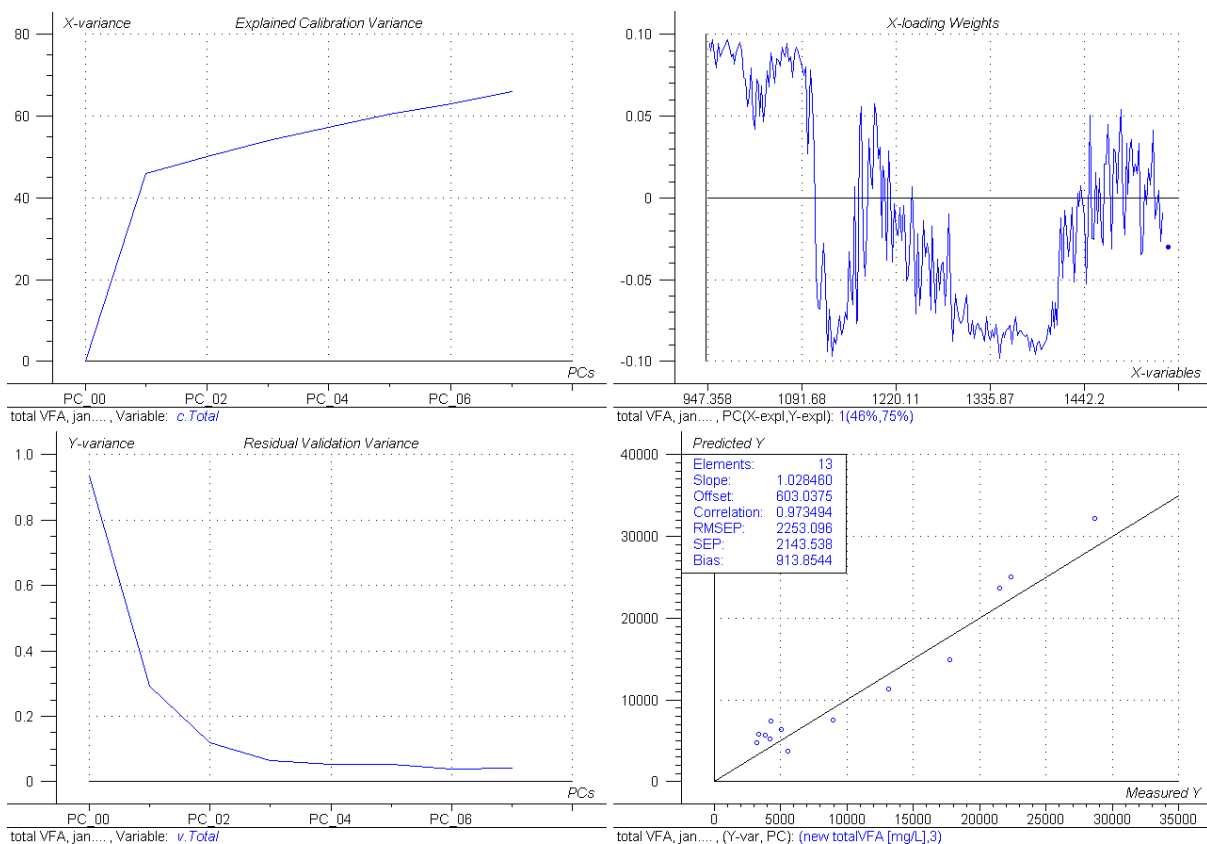

**Figure 7.11. Total VFA PLS-1 model; number of required PLS-components = 3; Two outliers were removed; Test set validation where data from the fermenter no.2 were tested against calibration data from fermenter no.1 and no.3; measures of precision:  $r^2 = 0.98$ , and accuracy; slope = 1.03 (Holm-Nielsen et al. 2007)**

The PLS-1 prediction model for total VFA from the setup of three replicate bio-slurry fermenters spiked with glycerol provided a highly satisfactory prediction model. Test set validation showed very good statistics for accuracy and precisions, Fig. 7.11. These on-line trials are successful in documenting the possibilities to measure total VFA conditions during increased feeding of concentrated feedstock's like glycerol spiking in anaerobic digestion systems.

## Initial full-scale PAT on-line studies at LinkoGas biogas plant during 2007. Volatile fatty acids influence on the gas production

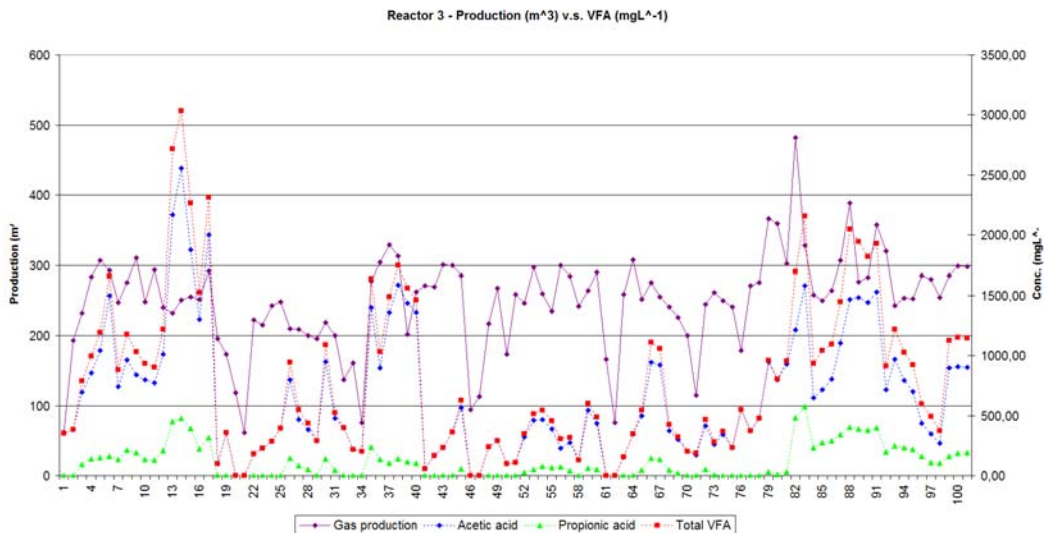

**Figure 7.12. Volatile fatty acids concentration v.s. biogas production (Conc. mg/L, Prod. m<sup>3</sup>)**  
Biogas production measures to the left hand side and VFA acid concentration levels to the right.

Figure 7.12 depicts the VFA concentration versus biogas production when samples were extracted. When the concentration of VFA increases, the production increases as well. Samples 20-21, 46-47 and 61-62 were taken during the fed-time; therefore, a low VFA concentration was expected. We cannot confirm that the VFA and the production drop for samples 18-21 were only due to the fed-time since the boiler broke down during this period. However, if we have a look at the daily biogas production, we can assume that the temperature drop had no significant influence on the biogas yield, since it stayed rather constant.

It can be seen that when the glycerol surplus, from delivering to the specific glycerol tank, was dumped into the common pre-storage tank on October 11<sup>th</sup>, the VFA content significantly increased (samples 11-17).

Multivariate data analysis in paper 4 where performed in two steps. Gross outliers were detected and removed from the data material using Principal Component Analysis (PCA) before building multivariate calibration models. Various pre-treatment methods were tested; Multiplicative Scattering Correction (MSC) and reduction of noisy parts in the spectra was performed.

### Validation considerations

The validation method should be as realistic as possible given the circumstances. After the trials reported in paper 3, it is emphasized that only test set validation is relevant for the real world, full scale bioconversion systems, due to the complex structure of the data matrix at LinkoGas. The full-scale study plant consists of extreme heterogeneous bioslurries as feedstocks and characterized with low concentration levels of the important VFA intermediates. The next step will be to continue the full scale trials, testing and make true test set validation. (Esbensen, 2002, Holm-Nielsen et al. 2007)

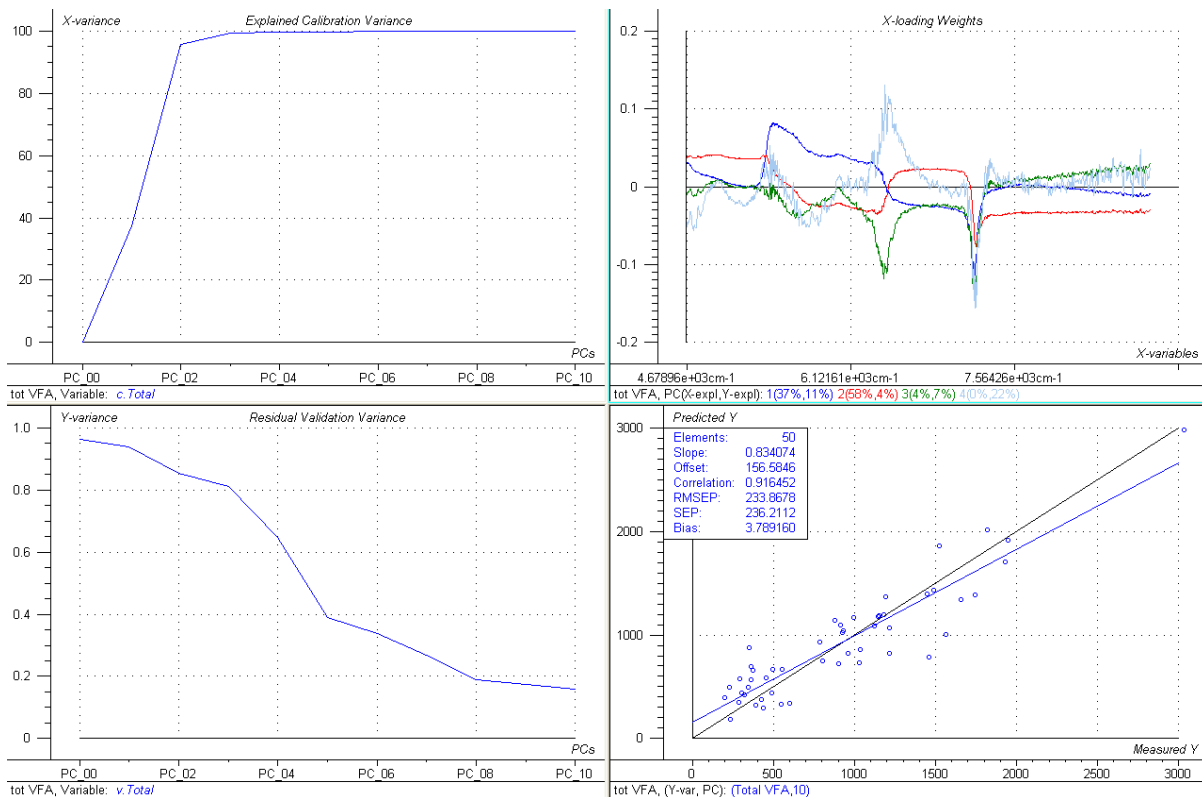

**Figure 7.13.** Measured vs. Predicted plot for the total VFA model. The black line (the diagonal) indicates the target line, while the blue line is the regression line. The VFA PLS-1 model; number of required PLS-components = 10; Two-segment cross validation was used due to low concentration dataset, and low spanning. Measures of precision:  $r^2 = 0.83$ , and accuracy; slope = 0.92 (Holm-Nielsen et al. 2008).

Biogas production yields measured by gas flow of the quantity and on-line measurements of gas quality are some of the easiest and important parameters to indicate the overall process and reactor performance. The main weakness is that these parameters cannot give an early warning and indication of the stress status of the fermentation behaviour; they are measuring the products and not the biological process. The combination with on-line monitoring of the VFA and other important intermediates including ammonium, paper 2+3+4, will provide extremely valuable information for improved on-line process control as is documented in this thesis. Biogas – anaerobic digestion is a process which can be much further regulated and fill in gaps in the energy supply chain at an advanced level in the future.

## 7.5 References:

Ahring B.K., M. Sandberg, I. Angelidaki, Volatile fatty acids as indicators of process imbalance in anaerobic digestors, *Applied Microbiology and Biotechnology* 43 (1995) 559–565.

Al Seadi T., Danish Centralised Biogas Plants—Plant Descriptions, 2005 (11 Feb.). <http://websrv5.sdu.dk/bio/pdf/rap2.pdf>.

Bakeev K.A. (Ed.). *Process Analytical Technology*. Blackwell Publishing. ISBN-10: 1-4051-2103-3, 2005.

Barampouti E.M.P., Mai S.T., Vlyssides A.G. (2005) dynamic modelling of the ratio volatile fatty acids/bicarbonate alkalinity in a UASB reactor for potato processing wastewater treatment. *Environmental Monitoring and Assessment*, 110:121-128.

Borjesson P., Mattiasson B. (2007) Biogas as a resource-efficient vehicle fuel. *Trends in Biotechnology*, 26 (1): 7-13.

Boe K., Batstone D.J., Angelidaki I. (2005) Online headspace chromatographic method for measuring VFA in biogas reactor. *Water Science and Technology*, 52 (1-2): 473-478.

Boe K. (2006) Online monitoring and control of the biogas process. PhD thesis, Institute of Environment and Resources, Technical University of Denmark , ISBN: 87-91855-09-8

Cord-Ruwish R., Mercz T.I., Hoh C., Strong G.E. (1997) Dissolved hydrogen concentration as an on-line control parameter for the automated operation and optimization of anaerobic digesters. *Biotechnology and Bioengineering*, 56 (6):626-634.

El-Gohary F.A., Nasr F.A., Aly H.I. (1999) Cost-effective pre-treatment of food-processing industrial wastewater. *Water Science and Technology*, 40(7): 17-24.

Esbensen, K.E. 2001: *Multivariate Data Analysis – in practice*. An introduction to multivariate data analysis and experimental design. Aalborg University, Esbjerg, Denmark. 5<sup>th</sup> edition. ISBN 82-993330-2-4.

FDA – PAT Guidance for industry; <http://www.fda.gov/cder/guidance/6419fnl.htm>, December 2005

FDA – PAT Initiative; <http://www.fda.gov/cder/OPS/PATreferences.htm>, December 2005

Feitkenhauer H., Sachs vJ., Meyer U., (2002) On-line titration of volatile fatty acids for the process control of anaerobic digestion plants. *Water Research* 36-1: 212-218

Guwy A.J., Hawkes F.R., Hawkes D.L., Rozzi A.G. (1997) Hydrogen production in a high rate fluidised bed anaerobic digester. *Water Resources* 31 (6): 1291-1298.

Gy P., Sampling for Analytical Purposes, John Wiley and Sons, 1996, ISBN: 0-471-97956-2

Hansson M., Nordberg A., Mathisen B. (2003) On-line NIR monitoring during anaerobic digestion treatment of municipal solid waste. *Water Science and Technology*, 48 (4): 9-13.

Hawkes F.R., Guwy A.J., Hawkes D.L., Rozzi A.G. (1994) On-line monitoring of anaerobic digestion: application of a device for continuous measurement of bicarbonate alkalinity. *Water Science and Technology*, 30 (12): 1-10.

Hickey R.F., Switzenbaum M.S. (1990) behaviour of carbon monoxide as a trace component of anaerobic digester gases and methanogenesis from acetate. *Environmental Science and Technology*, 24: 1642-1648.

Hill D.T., Bolte J.P. (1989) Digester stress as related to iso-butyric and iso-valeric acids. *Biological Wastes*, 28: 33-37.

Hjort-Gregersen K., Centralised Biogas Plants - Integrated Energy Production, Waste Treatment and Nutrient Redistribution Facilities, 2005 (11 Feb.). <http://websrv5.sdu.dk/bio/pdf/centra.pdf>.

Holm-Nielsen J.B., Dahl C.K., Esbensen K.H.: Representative sampling for process analytical characterisation of heterogeneous bioslurry systems – a reference study of sampling issues in PAT. Elsevier, *Chemometrics and intelligent laboratory systems*, vol. 83, pp. 114 - 126 (2006). DOI: 10.1016/j.chemolab.2006.02.002

Holm-Nielsen J.B., Andree H., Lindorfer H., Esbensen K.H.: Transflexive embedded near infrared monitoring of key process intermediates in anaerobic digestion/biogas production. *Journal of Near Infrared Spectroscopy*, vol. 15, pp. 123-135 (2007), DOI: 10.1255/jnirs.719

Holm-Nielsen J.B., Lomborg C.J., Oleskowicz-Popiel P., Esbensen K.H.: On-line Near Infrared monitoring of glycerol-boosted anaerobic digestion processes – evaluation of Process Analytical Technologies. Wiley, *Biotechnology and Bioengineering*, vol. 99, no.2, pp. 302–313, DOI: 10.1002/bit.21571

International Chemometrics Society (ICS), <http://www.chemometry.com/Index/Chemometrics.html>, May 2006

Jöreskog K. and H. Wold, 1981: The ML and PLS Techniques for Modelling with Latent Variables: Historical and Comparative Aspects, - in H. Wold and K. Jöreskog (Eds): *Systems Under Indirect Observation: Causality, Structure, Prediction*. Vol. 1, Amsterdam, North Holland, pp. 263-270.

Junker B.H., and Wang H.Y. 2006. Bioprocess monitoring and computer control; key roots of the current PAT Initiative, Wiley Periodicals, *Biotechnology and Bioengineering*, vol. 95, issue 2, pp 227 – 261

Kim M., Ahn Y-H., Speece R.E. (2002) Comparative process stability and efficiency of Anaerobic digestion; mesophilic vs. thermophilic. *Water Research* 36- 17: 4369-4385

Knicker H., (2004) Solid State NMR investigations of Organic matter conversions during solid waste processing. Resource Recovery and Reuse in Organic Solid waste Management. IWA Publishing. ISBN 1 84339 054 X

Koster I., (1986) Characteristics of the pH influenced adaptation of methanogenic sludge to ammonium toxicity. Journal of Chemical Technology and Biotechnology 36: 445-455

Lahav O., Morgan B.E. (2004) Titration methodologies for monitoring of anaerobic digestion in developing countries – a review. Journal of Chemical Technology and Biotechnology, 79: 1331-1341.

Legin A., Kirsanov D., Seleznev B., Rudnitskaya A., Holm-Nielsen J.B., Esbensen K., Vlasov Yu., (2003) Analysis of feedstuff from Biogas production plant by the electronic tongue. The 10<sup>th</sup> International Symposium on Olfaction and Electronic Nose. Book of Abstracts. ISBN 9984-18-222-3

Liu J., Olsson G., Mattiasson B. (2004) On-line monitoring of a two-stage anaerobic digestion process using a BOD analyzer. Journal of Biotechnology, 109: 263-275.

Madsen, M. (2007). Full-scale anaerobic digestion monitoring using on-line acoustic chemometrics, near infrared spectroscopy, and recurrent loop process sampling – a Process Analytical Chemometrics (PAC) feasibility study, master thesis, Aalborg University, Esbjerg Institute of Technology, Denmark

Marchaim U., Krause C. (1993) Propionic to acetic acid ratios in overloaded anaerobic digestion. Bioresource Technology, 43: 195-203.

Martens H. and T. Næs, 1991: Multivariate Calibration, Updated version, John Wiley and Sons.

McLennan F., Kowalski B.R. Process Analytical Chemistry. Blackie Academic & Professional (Chapman and Hall). ISBN 0-7514-0038-6. 1995

Moletta R., Escoffier Y., Ehlinger F., Coudert J.P., Leyris J.P. (1994) On-line automatic control system for monitoring an anaerobic fluidized-bed reactor: response to organic overload. Water Science and Technology, 30 (12): 11-20.

Mortensen P.P. 2006. Process Analytical Chemistry – Opportunities and Problems for Bio-industrial Implementation. Aalborg University Esbjerg. Ph.D. Thesis, ISBN:

Mortensen P.P. and R. Bro, “Real-time monitoring and chemical profiling of a cultivation process”, Chemometr. Intell. Lab. Syst. 83, 114-126 (2006). doi: 10.1016/j.chemolab.2006.04.022

Nordberg A., Hansson M., Sundh I., Nordkvist E., Carlsson H., Mathisen B. (2000) Monitoring of a biogas process using electronic gas sensors and near-infrared spectroscopy (NIR). Water Science and Technology, 41 (3): 1-8.



O'Flaherty V., Mahony T., O'Kennedy R., Colleran E., (1998) Effect of pH on growth kinetics and sulphide toxicity thresholds of a range of methanogenic, syntrophic and sulphate reducing bacteria. *Process Biochemistry* 33-5: 555-569

Perez M., Romero L.I., Sales D. (2001) Organic matter degradation kinetics in an anaerobic thermophilic fluidised bed bioreactor. *Anaerobe*, 7:25-35.

Petersen L. 2005. Pierre Gy's Theory of Sampling (TOS) in Practice: Laboratory and Industrial Didactics. Aalborg University Esbjerg, Denmark. Ph.D. Thesis. ISBN: 87-7606-004-7

Petersen, L., Esbensen, K.H. 2005. Sampling in practice: a TOS toolbox of unit operations. Proceedings – Baltic Biorefinery Symposium (BBS) May 26-28, 2005. AAUE, Esbjerg, page 129-140. ISBN 87-7606-009-8.

Petersen L., C.K. Dahl, K.H. Esbensen, Representative mass reduction in sampling—a critical survey of techniques and hardware, *Chemometrics and Intelligent Laboratory Systems* 74 (2004) 95–114.

Petersen L., P. Minkkinen, K.H. Esbensen, Representative sampling for reliable data analysis: theory of sampling, *Chemometrics and Intelligent Laboratory Systems* 77 (2005) 261–277.

Pind P.F., Angelidaki I., Ahring B.K. (2003) A new VFA sensor technique for anaerobic reactor systems. *Biotechnology and Bioengineering*, 82(1): 54-61.

Pitard F.F., Pierre Gy's Sampling Theory and Sampling Practice, 2 edn. CRC Press Ltd., 1993.

Punal A., Palazzotto L., Bouvier J.C., Conte T., Steyer J.P. (2003) automatic control of volatile fatty acids in anaerobic digestion using a fuzzy logic based approach. *Water Science and Technology*, 48 (6): 103-110.

Rego R., Mendes A. (2004) Carbon dioxide/methane gas sensor based on the permselectivity of polymeric membranes for biogas monitoring. *Sensors and Actuators B*, 103: 2-6.

Rodriguez J., Ruiz G., Molina F., Roca E., Lema J.M. (2006) A hydrogen-based variable-gain controller for anaerobic digestion processes. *Water Science and Technology*, 54 (2): 57-62.

Roychoudhury P., Harvey L.M., McNeil B. (2006). The potential of mid infrared spectroscopy (MIRS) for real time bioprocess monitoring. Elsevier, *Analytica Chimica Acta* 571, p. 159 – 166. doi: 10.1016/j.aca.2006.04.086.

Smith P.L., A Primer for Sampling Solids, Liquids, and Gases, Siam, 2001.

Spanjers H., Bouvier J.C., Steenweg P., Bisschops I., van Gils W., Versprille B. (2006) Implementation of in-line infrared monitor in full-scale anaerobic digestion process. *Water Science and Technology*, 53 (4-5): 55-61.

Steyer J.P., Bouvier J.C., Conte T., Gras P., Harmand J., Delgenes J.P. (2002) On-line measurements of COD, TOC, VFA, total and partial alkalinity in anaerobic digestion processes using infra-red spectrometry. *Water Science and Technology*, 45 (10): 133-138.

Steyer J.P., Bernard O., Batstone D.J., Angelidaki I. (2006) Lessons learnt from 15 years of ICA in anaerobic digesters. *Water Science and Technology*, 53 (4-5): 25-33.

Tosi S., Rossi M., Tamburini E., Vaccari G., Amaretti A., Matteuzzi D. (2003) Assesment of in-line near-infrared spectroscopy for continuous monitoring of fermentation processes. *Biotechnol. Prog.*, 19: 1816-1821.

Vanrolleghem P.A., Lee D.S. (2003) On-line monitoring equipment for wastewater treatment processes: state of the art. *Water Science and Technology*, 47 (2): 1-34.

Zhang Y., Zhang Z., Sugiura N., Maekawa T., (2001) Monitoring of methanogen density using near-infrared spectroscopy. *Biomass and Bioenergy* 22-6: 489-495



## 8 Papers prelude, thesis perspectivation and conclusion

### Introduction: Biogas process control and PAT

The general goal of the thesis studies have been to develop, demonstrate, and document new methods for real-time analysis of important intermediates in a biological process and secondly to develop sampling strategies for biofermentations. At the same time, the goal has been to document the possibilities of introducing on-line tools for monitoring and managing anaerobic digestion processes. As outlined previously, the substrates are very heterogeneous of nature and the anaerobic digestion process is highly complex. There have been several attempts to introduce process control in the AD-process without making the final implementation step for full scale operations. The work documented in this thesis is an important step towards the final implementation.

This thesis summarizes a series of studies, where Process Analytical Technologies (PAT) have been tested, studied, and implemented at different scales. The focus in paper 1 was to make the Theory of Sampling (TOS) operational in fermentation processes by introducing a one-dimensional pipeline flow in a recurrent loop mode. The pipeline loop was vertically up-streaming facilitating TOS-correct sampling. Paper 2 and 3 dealt with at-line and on-line studies of NIR and other sensors as tools for on-line monitoring and process control of biogas processes. In these studies, TOS-correct sampling, Process Analytical Chemistry (PAC), and multivariate data analysis have been the areas of focus. Supplementary studies and the final paper 4 document that the introduction of PAT tools will be possible for real-time, non-invasive advanced process control of AD processes.

### 8.1 Paper 1 – How to make the Theory Of Sampling operational in fermentation processes. Introduction of the recurrent process loop for sampling and monitoring of the anaerobic digestion process

**Title:** Representative sampling for process analytical characterisation of heterogeneous bioslurry systems - a reference study of sampling issues in PAT

**Authors:** Holm-Nielsen J.B., Dahl C.K. and Esbensen K.H.

**Published:** Journal of Chemometrics and Intelligent Laboratory Systems, 83 (2006), pp. 114 – 126. Available online 6 March 2006. DOI: 10.1016/j.chemolab.2006.02.002

#### ABSTRACT

Extensive experimentation and evaluation of alternative sampling methods of highly heterogeneous bio-slurries are carried out in the context of the Theory of Sampling (TOS) in order to delineate optimal, *representative* sampling procedures in PAT (Process Analytical Technologies). The analytical methods investigated are at-line NIR & image analysis (IA) for monitoring of an industrial bio-energy anaerobic digestion processes (AD), subject to stringent economic bracketing: PAT solutions have to be both *practical* and *inexpensive* in the bio-energy sector where cost efficiency of instrumentation and monitoring systems is an absolute must. Focus is on development of minimum expenditure methods for sufficient characterization of the very heterogeneous types of bio-mass feedstock as used in industrial scale, continuously stirred tank reactors (CSTR). Product and process characterization necessarily involves a chemometric multivariate calibration predictor (PLS-regression). The general goal is development of appropriate sampling/PAT facilities for at-line/on-line process monitoring in typically low-tech bioenergy, agro-industrial sectors.

Experimental laboratory reactor evaluations, based on biomass feedstock and digested products from a full-scale biogas plant, were initially run in batch mode for a week, followed by fed-batch addition of maize silage, introducing a systematic increase in total solids allowing properly spanning multivariate calibration models. Measurements on 55 laboratory reactor samples taken during a complete 14-day fermentation cycle included three key process parameters: total solids (TS), volatile solids (VS) and chemical oxygen demand (COD), representing difficult-to-sample analytes. NIR spectroscopy and image analysis, including the Angle Measure Technique transform (AMT), were evaluated for characterization of different feedstocks as well as continuously extracted process samples with respect to selected chemistry and dry matter characteristics. Optimized sampling on four different scale-levels allowed acceptable PLS-prediction models for TS and VS for both NIR and image analysis compared to chemical reference analysis, while it was not possible to predict the COD levels satisfactorily due to large uncertainties in mandatory reference measurement protocols. This feasibility study is promising for NIR as at-line prediction of TS and VS content as well as other AD parameters, which can be measured on the same sample types, while image analysis is currently too complex and expensive for these industry sectors. The findings in the present bio-slurries studies have a considerable generalization potential: all PAT approaches are critically dependent on *representative* reference calibration sampling, which has to be fully compliant with the Theory of Sampling (TOS).

**Keywords:** PAT (Process Analytical Technologies); Representative sampling; TOS (Theory of Sampling); chemometrics; AMT (Angle Measure Technique); image analysis; PLS-regression; anaerobic digestion; bioslurry; biogas production.

## 8.2 Paper 2 – Process monitoring of key process intermediates in anaerobic digestion. First step towards on-line monitoring of biogas production with NIR as a PAT tool

**Title:** Transflexive embedded near infrared monitoring for key process intermediates in anaerobic digestion/biogas production.

**Authors:** Holm-Nielsen J.B., Andree H., Lindorfer H., and Esbensen K.H.

**Published:** Journal of Near Infrared Spectroscopy, 15, pp. 123-135 (2007). DOI: 10.1255/jnirs.719

### Abstract

This work reports an off-line method development simulating at-line anaerobic co-digestion process monitoring using a new transflexive embedded near infrared sensor (TENIRS) system as a process analytical chemistry (PAC) facility. The operative focus is on optimising anaerobic digestion biogas production with energy crops as the main feedstock. Results show that several key monitoring intermediates in the anaerobic fermentation process can be quantified directly using near infrared spectroscopy with good results, especially ammonium and total volatile fatty acids. Good feasibility study prediction validations have been obtained for total solids (TS), volatile solids (VS), ammonium, acetic acid and total volatile fatty acids. The TENIRS system is a new option for real-time, at-line/on-line monitoring of biogas fermentation operations, offering a robust, low-budget PAC approach to a rapidly growing bulk volume industry.

**Keywords:** anaerobic digestion, biogas production, volatile solid s, volatile fatty acids, ammonium, NIR, PAC, TENIRS, multivariate calibration, PLS regression.

### 8.3 Paper 3 - Anaerobic digestion process control by direct on-line process analytical technology testing during glycerol spiking trials in laboratory fermentors

**Title:** On-line near infrared monitoring of glycerol-boosted anaerobic digestion processes-evaluation of process analytical technologies

**Authors:** Holm-Nielsen J.B., Lomborg C.J., Oleskowicz-Popiel P., and Esbensen K.H.

**Published:** Journal of Biotechnology and Bioengineering, 26 June (2007). DOI: 10.1002/bit.21571

#### ABSTRACT

A study of NIR as a tool for process monitoring of thermophilic anaerobic digestion boosted by glycerol has been carried out, aiming at developing simple and robust Process Analytical Technology modalities for on-line surveillance in full scale biogas plants. Three 5 litre laboratory fermentors equipped with on-line NIR sensor and special sampling stations were used as a basis for chemometric multivariate calibration. NIR characterisation using TENIRS (Transflexive Embedded Near Infra-Red Sensor) equipment integrated into an external recurrent loop on the fermentation reactors, allows for representative sampling, of the highly heterogeneous fermentation bio slurries.

Glycerol is an important by-product from the increasing European bio-diesel production. Glycerol addition can boost biogas yields, if not exceeding a limiting 5-7 g·L<sup>-1</sup> concentration inside the fermenter. Further increase can cause strong imbalance in the anaerobic digestion process. A secondary objective was to evaluate the effect of addition of glycerol, in a spiking experiment which introduced increasing organic overloading as monitored by volatile fatty acids (VFA) levels. High correlation between on-line NIR determinations of glycerol and VFA contents has been documented. Chemometric regression models (PLS) between glycerol and NIR spectra needed no outlier removals and only one PLS-component was required. Test set validation resulted in excellent measures of prediction performance, precision:  $r^2 = 0.96$  and accuracy = 1.04, slope of predicted vs. reference fitting. Similar prediction statistics for acetic acid, iso-butyric acid and total VFA proves that process NIR spectroscopy is able to quantify all pertinent levels of both volatile fatty acids and glycerol.

**Keywords:** Anaerobic digestion (AD) • near infrared spectroscopy (NIR) • on-line measurement • volatile fatty acids (VFA) • glycerol • process analytical technologies (PAT)

### 8.4 Process Analytical Technology: - Monitoring of Biogas Processes at Meso- and Full-Scale Biogas Plants

**Title:** Process Analytical Technology: - Monitoring of Biogas Processes at Meso- and Full-Scale Biogas Plants

**Authors:** Holm-Nielsen J.B., Larsen K.J., Møller H., Møller H.B., Njoku S., Boland L., Madsen M. and Esbensen K.H.

**Submitted:** May-2008 to *Journal of Biotechnology and Bioengineering, Wiley Periodicals, Inc.*

#### Abstract

Biogas plants converting animal manure materials and other biomass products by anaerobic digestion (AD) are among the cheapest and most effective tools for achieving post-Kyoto targets concerning reduction in the emission of greenhouse gases of CO<sub>2</sub>, CH<sub>4</sub>, N<sub>2</sub>O. Focus in this study is on meso- and full-scale biogas plant implementation of Process Analytical Technologies (PAT) to develop chemometric multivariate calibration and prediction models for on-line monitoring and control of the anaerobic digestion process in a re-current loop modus. The larger goal is to prepare

for implementation of on-line monitoring and control applications in the biogas and biorefinery sectors, in order to be able to adjust the process according to the varying demands in the bioenergy and sustainable products market.

Most studies reported in the literature have investigated near infrared spectroscopy (NIR) in laboratory-scale or minor pilot biogas plants; only very few studies exist for on-line process monitoring of full-scale biogas plants. It is here necessary to obtain a fairly constant level of VFA concentration which leads to a stable biogas production. VFA concentration levels should not exceed 4-5000mg/l. On-line control and management of VFA concentration levels can speed up or slow down the AD-process. We present two case studies:

Case 1 - “Bygholm trials”: By comparing pilot plant NIR-spectra to laboratory VFA reference concentrations at the experimental locality *Bygholm*, it was possible to develop highly satisfactory calibration models by Partial Least Squares (PLS) regression, i.e. acceptable to very good PLS-prediction models for total VFA as well as for all essential individual acids. The average statistics assessing prediction performance, accuracy (slope-value) and precision: correlation ( $r^2$ ), were both 0.92. VFA contents had a significant impact on biogas production.. Bygholm studies took place in a meso-scale 150 L bioreactor.

Case 2 - “Linkogas trials”: For full-scale PAT-implementations, primary sampling representativity is critical and needs continuing improvement as shown in this study. To meet complete satisfaction it is needed to introduce automated sampling devices at optimal placements in the process. The *LinkoGas biogas plant* has a naturally low VFA concentration level due to the feedstock composition consisting primarily of cattle and pig manure and food waste. This brings forth challenges in gathering reference samples for multivariate calibration and validation. It is mandatory that samples in particular reflect the expected *future* variability of the substrate. Prediction precision ( $r^2$ ) in the developed multivariate model of VFA was also here 0.92 while accuracy (slope) was 0.83, also a fully acceptable model taking the inherent heterogeneity and complexity of the system into account. The Linkogas bioreactors are of size 2400 m<sup>3</sup>. The present results helps in developing affordable, robust non-invasive PAT technologies dedicated for regulation of all major types of biogas plants as well as biorefineries world-wide.

**Keywords:** on-line monitoring, Near InfraRed spectroscopy (NIR), anaerobic digestion (AD), volatile fatty acids (VFA), Process Analytical Technologies (PAT), representative Sampling, Theory of Sampling, (TOS), Biogas Production, Biorefinery.

## 8.5 Thesis perspectives - Biomass, bioenergy, biorefineries

The thesis perspectives are clear. The AD process needs efficient on-line controlling in the near future in order to gain increased market shares. Both as a proven biotechnological facility for processing problematic organic wastes, but also as an innovative technology for large-scale production of clean, renewable energy and integrated production of energy, chemicals, and fertilisers via application of biorefining concepts. Even though the process utilizes highly complex substrates setting up extensive requirements for efficient control of the processes, the selected PAT sensor systems in combination with TOS and Process Analytical Chemometrics show good prospects to be developed into robust tools for efficient tailoring of the AD process. Monitoring and control can be made non-invasive and real-time using innovative sensor technologies.

The AD process/biogas production technically has the potential to become a fully integrated energy source in the future European energy sector. Biogas production can be one of the most flexible and adjustable energy sources while simultaneously being able to treat some of the most problematic - in some cases low value, products of organic substrates and by-products produced by societies. Organic waste from the food-processing sector and the bioslurries from the animal sector can have major negative impacts on the water environment, air pollution, and human and animal health. Therefore, there is an urgent need for safe and well-managed AD technologies for treating these wastes.

If full scale implementations of PAT technologies are matured and commercialized in a few years, the next step will be to introduce these advanced process control tools into the liquid biofuels fermentation processes and biorefinery sectors. The biorefinery sectors worldwide are currently making huge investments. There is a serious need to be as advanced in process monitoring and control regarding PAT instrumentation – as in the leading food processing and pharmaceutical sectors. Specifically, in the pharmaceutical sector all new technology implementation steps are extremely resource demanding due to high hygienic, health, and product standards. In the biorefinery sectors, control needs are equally important due to the large volumes of forecasted production/waste products in the coming decade. To control and optimize the products during fermentation and to develop standardized products for the biofuels sectors in relation to conventional oil refinery products is of high relevance. This presents us with extremely complex and fascinating scientific and technological challenges.

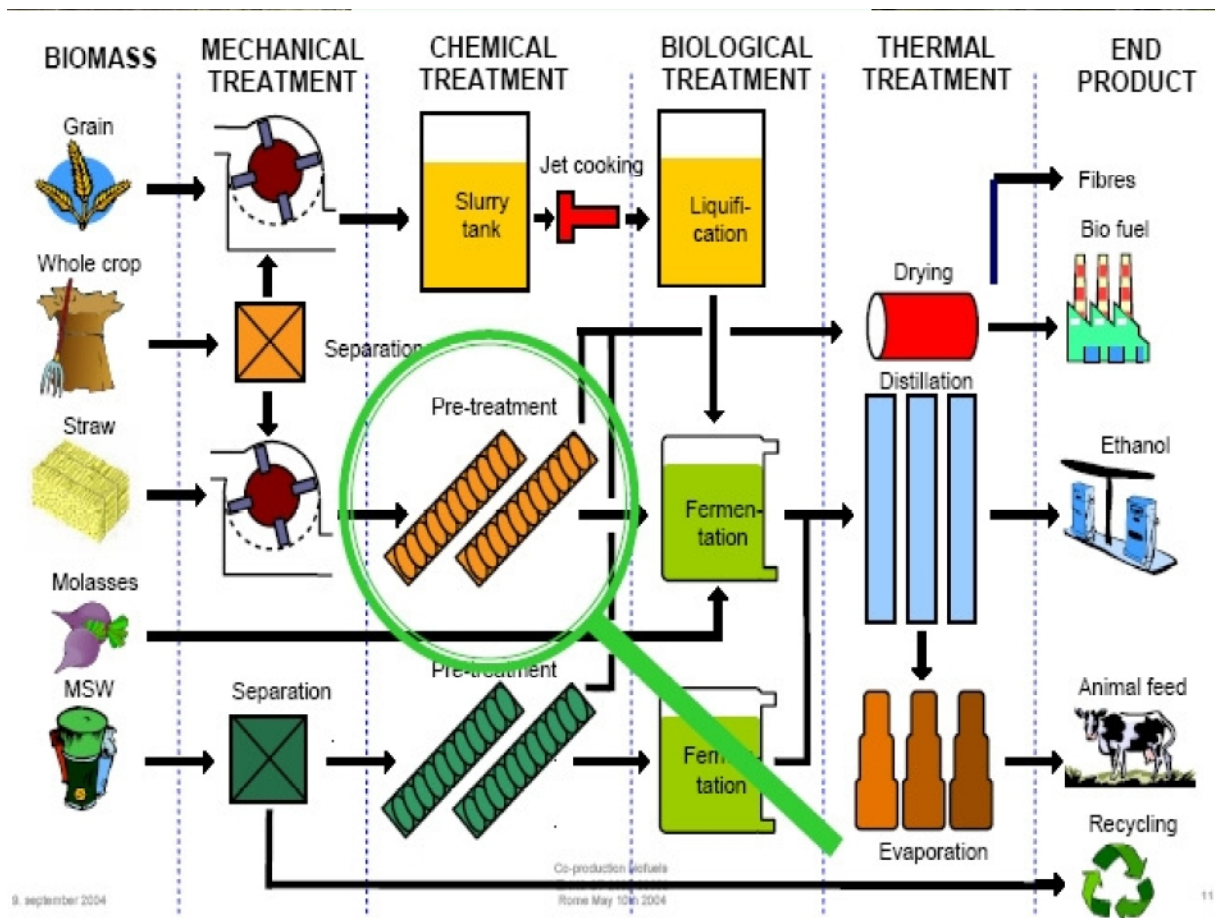



Figure.8.1 Biorefinery concept. Biorefineries are complex production clusters where the sources (raw materials) are e.g. biomass from agriculture forestry and society, resulting in a broad range of processed products, for example foods / feeds / fuels / fibres and fertilizers. The figure illustrates typical stages /treatments in integrated biomass utilization systems (Nielsen C. et al. 2005). Pre-treatment of ligno-cellulosic materials is crucial for future biorefining.

As delineated in Fig. 8.1, the biorefinery concept includes several mechanical, physical, chemical, and biological pre-treatment and processing steps. Integrated PAT tools are critically necessary to control and manage these very different processing steps, without which it would not be possible to optimize the biorefinery plants. Applied industrial biotechnology is developing rapidly due to society's need for environmentally friendly biofuels and food, feed, fibres, fertilizers in conjunction with the security of energy supplies and climate protection initiatives. The photosynthesis activities need in this context to be improved, utilizing the biogenic resource base for biorefining from agricultural areas.

Biorefineries have been rapidly developing in the last 5-7 years. Biomass sources will increasingly become all-round competitive alternatives to crude oil as feedstocks for fuels, chemicals, and materials, keeping a balance with their role as raw materials for food and feed production. Many of these obligations will be fulfilled by *integrated* biorefinery processing facilities for optimal yield and energy efficiency. Biomass conversion and utilization for the future will be very different from biomass utilization before the industrial revolution. It will also be different compared to the mono-processing facilities in the 20<sup>th</sup> century, i.e., sugar factories, grain or potato starch processing plants. New synergistic multi-process flows will be developed much further than yesterday's single-line processing plants. The resulting product portfolio for society will have the potential to replace petro-chemically synthesized products and allow new sustainable bio-products to find their ways to the markets. One example would be new biomass-based building and insulation materials made directly from processed fibers and plant materials. This points in the direction of a new building paradigm shifts based on integrated biomass-based materials.

Another important lesson learned from the initial stages of biorefining is a trend to move towards *decentralized* ways of production, in strong contrast to the prevailing 20<sup>th</sup> century view of centralized strategies. In the design of such modern biotechnological processes and process equipment where the units will be as simple and robust in utilization as i.e., refrigerators or washing machines, the initial phases of these innovation steps have begun. The *economy of scale* will be replaced by the *economy of numbers* (Born, 2005). Micro fuel-cell implementation programs running on biofuels for combined production of electricity and heat in domestic housing exemplify this idea well. This will fulfill the idea of a bottom up approach as a virtual power plant, compared to the top-down coal- and nuclear centralized power plants concepts from the last century. Biomass-based resources integrated with fuel-cells - in which the fuel itself is bioethanol, biomethanol, biogas, biomethane, or biohydrogen - is a fascinating concept, because all the raw materials can be produced at a rural biorefinery scale. The end product, exemplified by biogas, can then be distributed through the existing natural gas grid system to the houses in the urban areas.

The ultimate perspectives for biorefineries are as processing facilities that include new centralized innovative technologies fueled by renewable energy sources like electricity/heat/steam generated from wind, solar, and biomass resources. Such biorefineries will process a wide range of high- and medium value products needed by society to replace fossil fuel-based products. The technologies involved are all known today, and they are all based on flexible, more or less non-sterile, fermentation processes (Born, 2005). Biorefineries can be considered to be a "Bridge between

Agriculture and Chemistry” (Braun, 2005) designed to produce basic and intermediate organic chemicals and fuels for direct or further product developments.

One of the most valuable by-product lines in the biorefinery is the anaerobic digestion step. It is a fully integrated part of the biorefinery processing, due to its efficient utilization of by-products and waste streams from various other biological and biotechnological production processes. It is an important second step, producing biogas for integration in the overall process energy needs and producing biofertilizers for further processing or recycling to the agricultural sector to replace conventional chemical fertilizers. With the biorefinery concept there are endless new possibilities for making highly significant contributions towards the ultimate closed-system eco-solutions society will need in the nearest future. Optimizing the AD process forms an important stepping stone towards this responsible energy future, in which green engineering and biotechnology contributes to the societal evolution in a most reflective manner. These solutions have the attribute of being ideologically invariant – they function in both capitalist as well as socialist economies all over the world. Profit need absolutely not necessarily to be the primary driving force, indeed this would be distinctly suboptimal, compared to environmental concerns, pollution pressure and global warming.

## 8.6 Thesis Conclusions

The first study showed promising results for near infrared spectroscopy (NIR) as an at-line prediction tool for total solids (TS) and volatile solids (VS) content as well as other anaerobic digestion (AD) parameters, which can be measured in the same sample, while image analysis currently appears as too complex and expensive for the bioenergy sector. The major findings have a considerable generalization potential: all Process Analytical Technology (PAT) approaches are critically dependent on *representative* reference calibration sampling, which has to be fully compliant with the Theory of Sampling (TOS).

Further results showed that several key monitoring intermediates in the AD fermentation process can be quantified directly using NIR with good results, especially ammonium and total volatile fatty acids (VFA). Good feasibility study prediction validations were obtained for TS, VS, ammonium, acetic acid, and total VFA. The Transflexive Embedded Near InfraRed Sensor (TENIRS) system is a new option for real-time, at-line/on-line non-invasive monitoring of biogas fermentation operations. TENIRS offers a robust, low-budget PAT approach to a rapidly growing bulk volume bioenergy industry.

Also, high correlations between on-line NIR determinations of glycerol and VFA content have been documented. Partial Least Squares (PLS) regression models between glycerol and NIR spectra needed no outlier removals and only one PLS-component was required. Test set validation resulted in excellent measures of prediction performance. Similar prediction statistics for acetic acid, isobutanoic acid and total VFA proves that process NIR is able to quantify all pertinent levels of both VFA and glycerol.

## Lessons learned in full-scale plants

It was not an easy task to obtain large span in the calibration data sets, for example for VFA concentration in full-scale continuous fermentation processes with volumes of 2400 m<sup>3</sup>. Many unforeseen irregularities occurred. Even with a flexible research and trial planning, one will probably never know with certainty at AD plants when seriously different situations w.r.t. flow and

concentration changes of feedstock, or which type of menial technical problems occur. Nevertheless, full-scale testing has led to a novel insight in TOS-correct process sampling, implementation of NIR sensors and other issues concerning utilization of the recurrent loop concept.

New ideas are in research that include the testing of Mid InfraRed (MIR) and acoustic sensors in the same recurrent loop containing the embedded NIR sensor. MIR sensors have a great deal to offer in combination with NIR measurements (Roychoudhury, 2006), the sensors will be able to detect and quantify analytes present at very low, but critically limiting levels. This is the strength of MIR compared to NIR, with typical detection limits below the range between 500-1000 mg/l concentrations. MIR will have the possibility of distinguishing between different sugars and other important analytes, which is essential in full-scale fermentation plants and in biorefineries. Integration of robust, relatively inexpensive NIR/MIR technologies will have the ability of supplementing each other in many biotechnological on-line fermentation industries as applied in a non-invasive, real-time context. This will be welcomed due to the bioenergy sector's need for lowering implementation costs of the entire PAT control systems envisaged, also maintenance costs will likely be more affordable.

### **Next steps towards commercial utilization of PAT**

The introduction of PAT tools into the biogas and biorefinery sectors are in progress. Initial implementation stages have been set up in cooperation with a consortium of companies. Unbalanced biogas plant operations exist, and the need for real-time monitoring and control is demanded. Often, the carbon/nitrogen (C/N) balance is underestimated, which occurs by oversupply of feedstock's rich in protein and other nitrogen sources. At thermophilic biogas plants, an inhibitory level of ammonia can be a critical problem at levels above 3,2 g/l. The ammonia concentration as well as VFA concentrations can now be easily controlled by implementing on-line NIR PAT-solutions.

### **The role of AD in the green biorefinery revolution**

The emerging concepts of Process Analytical Technologies (PAT) have the opportunity to play a major role in process control in the future. This thesis focused in particular on the AD process. To fully utilize the potential for monitoring and control with PAT it is essential to employ TOS-representative samples for chemical control, for on-line insight, and for test set validation. Timely and reliable data are of critical importance in fermentation processes, to monitor and control large volumes of biomass, substrates, intermediates and nutrients by on-line information. Only on this basis can real-time insight and reliable process control be obtained- and optimized. Problem-dependent PAT will no doubt be implemented as on-line tools in today's and tomorrow's AD and other fermentation industries. The bioconversion sector is destined to be on the upswing in the 21<sup>st</sup> century: Bioenergy being the most important single representative. Fixed goals for bioenergy and biofuels replacement of fossil fuels have already been set by EU, China, and USA, which are some of the major players involved, but sustainable guidelines have to be implemented in a UN contextual agreement urgently.

Integrated biorefinery production facilities are part of the future – including advanced bio-industrial process control, which comprises a critical success factor for this development.

This thesis has tried to map out some possible roles for a selected set of key process technological elements in this framework. Representative sampling in the context of TOS, NIR, MIR, acoustics, image analysis. Innovative, non-invasive, robust process technologies will come on board with growing importance assisting the emerging bioenergy and biotechnological sectors world-wide. PAT has a vital role to play in this context.

## **8.7. References**

Born J. (2005). From Sugar Factories to Biorefineries. Baltic Biorefinery Symposium, June 2005, ISBN: 87-7606-009-8, p. 23 – 32

Braun R. (2005). Biogas and bioenergy system developments towards biorefineries. Trends in a central European context. Baltic Biorefinery Symposium, June 2005, ISBN: 87-7606-009-8, p 93 – 104

Nielsen C., Larsen J., Iversen F., Morgen C., Holm Christensen B.(2005). Integrated biomass utilization system. Baltic Biorefinery Symposium, June 2005, ISBN: 87-7606-009-8, p 115 - 120

Roychoudhury P., Harvey L.M., McNeil B. (2006). The potential of mid infrared spectroscopy (MIRS) for real time bioprocess monitoring. Elsevier, *Analytica Chimica Acta* 571, p. 159 – 166. doi: 10.1016/j.aca.2006.04.086.



## 9 Full publication list

Publications with contributions of the author of this thesis are listed below. Both published and submitted publications are included as well as proceedings and papers presented at international conferences.

1. Holm-Nielsen J.B., Dahl C.K., Esbensen K.H.: Representative sampling for process analytical characterisation of heterogeneous bioslurry systems – a reference study of sampling issues in PAT. *Chemometrics and intelligent laboratory systems* vol. 83, 114 – 126 (2006) ScienceDirect, Elsevier. DOI: 10.1016/j.chemolab.2006.02.002
2. Holm-Nielsen J.B., Andree H., Lindorfer H., Esbensen K.H.: Transflexive embedded near infrared monitoring for key process intermediates in anaerobic digestion/biogas production. *Journal of Near Infrared Spectroscopy* vol. 15, 123-135 (2007) ISSN 0967-0335. DOI: 10.1255/jnirs.719
3. Holm-Nielsen J.B., Lomborg C.J., Oleskowicz-Popiel P., Esbensen K.H.: On-line Near Infrared monitoring of glycerol-boosted anaerobic digestion processes – evaluation of Process Analytical technologies. *Biotechnology and Bioengineering*, Vol. 99, No. 2, p 302-313, (2008) Wiley Periodicals, Inc. – InterScience. DOI: 10.1002/bit21571
4. Holm-Nielsen J.B., Larsen K.J., Møller H., Møller H.B., Njoku S., Boland L., Madsen M. and Esbensen K.H.: Process Analytical Technology - monitoring of biogas processes at Meso- and Full-Scale Biogas Plants. *Submitted May-2008 to Journal of Biotechnology and Bioengineering, Wiley Periodicals, Inc.*
5. Lomborg C. J. , Holm-Nielsen J.B., Oleskowicz-Popiel, Esbensen K.H.: Near Infrared and acoustic chemometric monitoring of volatile fatty acids and dry matter during co-fermentation of manure and maize silage – a biomass conversion Process Analytical Technologies (PAT) feasibility. Paper submitted to: *Biotechnology and Bioengineering*; Wiley, 2008.
6. Holm-Nielsen J.B., al Seadi T.: Manure-based biogas systems – Danish Experience. Chapt. 17; p 377-394 in *Resource Recovery and Reuse in Organic Solid Waste Management*. IWA Publishing, 2004. ISBN 1 84339 054 X
7. Holm-Nielsen J.B., Madsen M., Oleskowicz-Popiel P.: Predicted Energy Crop Potentials for Bioenergy Worldwide and for EU-25. *Proceedings World Bioenergy 2006, Conference on Biomass for Energy, Jönköping, Sweden, 30. May – 1.June 2006.*
8. Holm-Nielsen J.B., Oleskowicz-Popiel P., al Seadi T.: Energy Crop Potentials for Bioenergy in EU-27. *Proceedings 15<sup>th</sup> European Biomass conference, Berlin, Germany 7-11 May 2007.* ISBN 3-936338-21-3.
9. Esbensen K.H., Friis-Petersen H.H., Petersen L., Holm-Nielsen J.B., Mortensen P.P.: Representative Process Sampling – in practice: Variographic Analysis and Estimation of

Total sampling Errors (TSE). Chemometrics and Intelligent Laboratory Systems – Proceedings from 5<sup>th</sup> Winter School of chemometrics (WSC5) 2006.

10. Oleskowicz-Popiel P., Lisiecki P., Holm-Nielsen J.B. Thomsen A.B., Thomsen M.H.,: Ethanol production from maize silage as lignocellulosic biomass in anaerobically digested and wet-oxidized maize. *Bioresource Technology* , 2007, in print. (BITE-D-07-00728R2).
11. Thomsen M.H., Holm-Nielsen J.B. Oleskowicz-Popiel, Thomsen A.B.: Bioenergy potentials of maize silage. Proceeding at Biotechnology conference Denver, USA, May 2007.
12. Legin A., Kirsanov D., Seleznev B., Rudnitskaya A., Holm-Nielsen J.B., Esbensen K., Vlasov Yu., (2003) Analysis of feedstuff from Biogas production plant by the electronic tongue. The 10<sup>th</sup> International Symposium on Olfaction and Electronic Nose. Book of Abstracts, p. 252 – 255, (2003). ISBN 9984-18-222-3
13. Holm-Nielsen J.B. and Oleskowicz-Popiel P. 2007: The Future of Biogas in Europe: Visions and targets until 2020; Proceedings: European Biogas Workshop – Intelligent Energy Europe, 14- 16 June 2007, Esbjerg, Denmark.

# Paper I

Jens Bo Holm-Nielsen, Casper K. Dahl, Kim H. Esbensen

*Representative sampling for process analytical characterization of heterogeneous bioslurry systems  
– a reference study of sampling issues in PAT*

Chemometrics and intelligent Laboratory Systems  
Volume 83, pp. 114-126, 2006

DOI: 10.1016/j.chemolab.2006.02.002





# Representative sampling for process analytical characterization of heterogeneous bioslurry systems—a reference study of sampling issues in PAT

Jens Bo Holm-Nielsen\*, Casper K. Dahl, Kim H. Esbensen

ACABS Research Group, Aalborg University Esbjerg, Niels Bohrs Vej 8, DK-6700, Esbjerg, Denmark

Received 29 March 2005; received in revised form 28 December 2005; accepted 13 February 2006

Available online 6 March 2006

## Abstract

Extensive experimentation and evaluation of alternative sampling methods of highly heterogeneous bioslurries are carried out in the context of the theory of sampling (TOS) in order to delineate optimal, *representative* sampling procedures in PAT (process analytical technologies). The analytical methods investigated are at-line NIR and image analysis (IA) for monitoring of an industrial bioenergy anaerobic digestion processes (AD), subject to stringent economic bracketing: PAT solutions have to be both *practical* and *inexpensive* in the bioenergy sector where cost efficiency of instrumentation and monitoring systems is an absolute must. Focus is on development of minimum expenditure methods for sufficient characterization of the very heterogeneous types of biomass feedstock as used in industrial scale, continuously stirred tank reactors (CSTR). Product and process characterization necessarily involves a chemometric multivariate calibration predictor (PLS regression). The general goal is development of appropriate sampling/PAT facilities for at-line/on-line process monitoring in typically low-tech bioenergy, agro-industrial sectors. Experimental laboratory reactor evaluations, based on biomass feedstock and digested products from a full-scale biogas plant, were initially run in batch mode for a week, followed by fed-batch addition of maize silage, introducing a systematic increase in total solids allowing properly spanning multivariate calibration models. Measurements on 55 laboratory reactor samples taken during a complete 14-day fermentation cycle included three key process parameters: total solids (TS), volatile solids (VS) and chemical oxygen demand (COD), representing difficult-to-sample analytes. NIR spectroscopy and image analysis, including the angle measure technique transform (AMT), were evaluated for characterization of different feedstocks as well as continuously extracted process samples with respect to selected chemistry and dry matter characteristics. Optimized sampling on four different scale-levels allowed acceptable PLS prediction models for TS and VS for both NIR and image analysis compared to chemical reference analysis, while it was not possible to predict the COD levels satisfactorily due to large uncertainties in mandatory reference measurement protocols. This feasibility study is promising for NIR as at-line prediction of TS and VS content as well as other AD parameters, which can be measured on the same sample types, while image analysis is currently too complex and expensive for these industry sectors. The findings in the present bioslurries study have a considerable generalization potential: all PAT approaches are critically dependent on *representative* reference calibration sampling, which has to be fully compliant with the theory of sampling (TOS).

© 2006 Elsevier B.V. All rights reserved.

**Keywords:** PAT (process analytical technologies); Representative sampling; TOS (theory of sampling); Chemometrics; AMT (angle measure technique); Image analysis; PLS regression; Anaerobic digestion; Bioslurry; Biogas production

## 1. Introduction

Fermentation processes at large-scale biogas plants are sensitive to sudden changes in feedstock composition, which cause significant variability in the process conditions. Today,

fermentation process control is achieved through manual sample extraction (shown below to be highly problematic due to the very heterogeneous nature of the fermentation media) with off-line (sometimes even off-site) analysis of a few key process parameters such as total solids (TS), volatile solids (VS) and chemical oxygen demand (COD), as well as volatile fatty acids (VFA), total-N and ammonia content. However, other parameters, e.g., process temperature, pH, volumetric biogas yield as well as methane, carbon dioxide and hydrogen sulfur content

\* Corresponding author.

E-mail address: [jhn@aaue.dk](mailto:jhn@aaue.dk) (J.B. Holm-Nielsen).

URL: <http://www.acabs.dk> (J.B. Holm-Nielsen).

in the gaseous headspace of the reactor, are also monitored more-or-less on-line as control parameters in more advanced plants [1,2].

Even though time-constants involved in anaerobic digestion (AD) are not critically short (average hydraulic retention time of feedstock in a semi-continuously fed-batch digestion system is of the order of 10 to 25 days), there is nevertheless a desire for implementation of on-line technologies, of a distinctly inexpensive, robust types. The perspective is to develop real-time process monitoring data at full-scale commercial biogas plants above a certain minimum size to be used for improved routine managing tools, i.e., for identification of critical process state parameters, upsets and for monitoring when unavoidable deviations in feedstock composition occurs. By combining low-tech, but reliable sensors with critical at-line facilities if/where/when physical samples must be examined, the goal is to contribute towards a new generation of fully integrated process management systems for the daily operating plant staff [3,4]. This endeavor fits well with current EU renewable energy initiatives for considerably increased utilization of biofuels including biogas, integrated in the overall energy as electricity, heat and in the transportation fuel sectors.

Improved control of this type of fermentation processes especially calls for more controllable raw materials characterization throughout, which today are often based on slow off-line measurements. Improved optimization of anaerobic digestion processes can only be achieved by incorporating new, relevant sensor technologies for semi-continuous at-line/on-line measurements of the composition of both raw materials and processed biomass at important process stages. The most relevant sensor deployment locations with this scope include:

- *Feedstock* arrival depositories (raw materials)
- *Inlets* (feed-points) for fermentation reactors
- *In-process deployments* (in reactors and transportation pipelines)
- *Outlets* (exit-points) for the fermentation reactors

Any process analytical technology (PAT) is critically dependent on the representativity of the signals obtained from on-line or in-line probes or sensors in pipelines or reactor tanks as well as representativity of the samples analysed for calibration. For example, what is the relationship between a sensor or probe's field-of-view (a few mm<sup>2</sup>) in relation to the entire cross-section of a transportation pipeline or the entire reactor volume in question? What with TOS is termed "incorrect sampling procedures", which are legion in the AD regimen, will always result in biased, non-representative and hence unreliable analytical results [5–9]. All traditional sampling procedures involved in the general AD process flow are therefore carefully evaluated in the present study in the light of TOS (theory of sampling) and the specific sampling errors are estimated where needed in order to put these hitherto largely neglected sampling issues on a firm quantitative footing.

Sampling is a critical component in any analytical procedure and must always ensure representativity of the primary,

secondary and tertiary sampling steps. Total sampling errors typically can be in the order of 100+ times the specific analytical error. "Incorrect sampling" always results in non-representative samples because of an uncontrollable bias even though all subsequent steps have been performed in a correct way [5–8].

Animal manure forms a highly complex and heterogeneous suspension because of a significant proportion of solids, "dry matter" (3–12%): straw, grass, undigested lignocellulosic fiber particles, besides not yet digested macromolecule aggregates such as starch, sugars and proteins. Such suspensions are therefore always prone to segregation on several scales, which sets in immediately after agitation has been terminated. Sampling from such systems consequently will introduce a significant sampling bias if not properly counteracted, wherefore this study will deal exhaustively with all relevant sampling issues using the complete TOS toolbox [8]. In this context, focus will be on a general sampling hierarchy, covering all aspects from primary field sampling to the ultimate, apparently insignificant, mass reduction involved in securing the often minute analytical volume.

This study also evaluates the potential of an imaging technique in characterizing important physical and chemical parameters. Since NIR reflectance/transmission has shown good potential in mixed liquids in linked fermentations sectors, a NIR reflectance system was employed for reference comparison and/or as the main PAT technique. NIR has been tested extensively with varying degrees of success as a spectroscopy tool for on-line bioslurry monitoring of continuous AD systems and similar [2,10–13].

We here combine image analysis (IA) and the angle measure technique (AMT), a powerful texture extraction technique [14–19], with chemometric multivariate modeling (PLS-R) in a pilot study with a potential for on- or at-line monitoring and prediction of visible features such as the surface manifestation of bioslurries and the TS content. By virtue of stoichiometric closed array relationships, there is also a possibility for *indirect* multivariate calibration modeling for correlated parameters, VS and perhaps even COD a.o. Such methods constitute a potential for monitoring and optimization of full-scale production plants.

## 2. Sampling in AD systems for multivariate calibration

Procurement of feedstock as well as digested biomass in preparation for AD trials and testing took place at a full-scale industrial biogas plant, the Ribe Biogas plant, Denmark. Primary and secondary sampling and preparation will be described in detail below. Experimental fermentation trials—including a tertiary sampling step—is a commonly used procedure both in academic studies as well as in commercial laboratories to study biomass feedstock compositions and to characterize their biogas potentials [1,2]. This is followed by a quaternary sampling procedure for securing representative analytical samples for the final NIR and IA analysis. Fig. 1 is a schematic illustration of the entire AD process and the attendant sampling hierarchy as examined in this study.

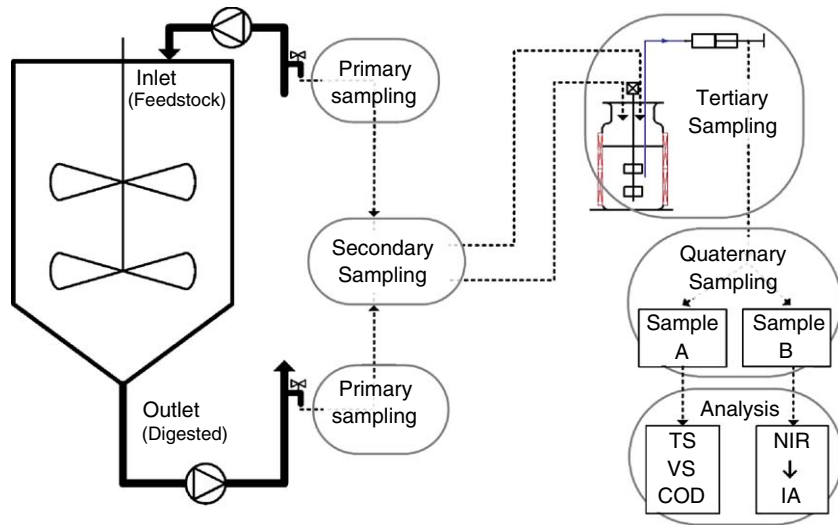

Fig. 1. Schematic illustration of the necessary sampling hierarchy for the AD process, including primary sampling at the full-scale biogas plant, secondary sampling preparing samples for fermentation trials, tertiary sampling from laboratory fermentation reactor and quaternary sampling associated with analysis.

2.1. Primary sampling: full-scale biogas plant

Appropriate field sampling procedures based on TOS were employed in order to obtain proper extraction of primary samples from a full-scale biogas plant, the Ribe Biogas plant. The feedstock in terms of total solid contents is here composed of approximately 80% pig and cattle manure to which is added ~20% industrial organic waste from Danish food processing plants (primarily from slaughteries). All feedstocks of this origin utilized for biogas production are very heterogeneous by nature and thus constitute a relevant vehicle for displaying all issues involved when sampling heterogenous materials in general.

Suitable primary extraction sites were located for both feedstock and final digested biomass sampling. Significant

gravitational segregation always occurs in horizontal pipelines with higher concentration of solid material along the bottom. Thus, it was decided to sample from a vertical pipeline through side-valves: upward flow greatly facilitates mixing due to turbulence, gravity now acting to boost mixing. The pre-mixed feedstocks was extracted *before* addition to the full-scale fermentation reactor (Fig. 2, left), while digested biomass was sampled directly at the outlet pipeline immediately *after* the fermentation reactor (Fig. 2, right).

It is not only important to point-sample heterogeneous material in well-mixed upflow pipelines—it is equally important to employ extensive time-averaging composite sampling schemes, tuned to the specific situation(s). Thus, primary sampling took place by spanning eight buckets each of 10L of biomass with 3-min intervals in the continuous pumping.

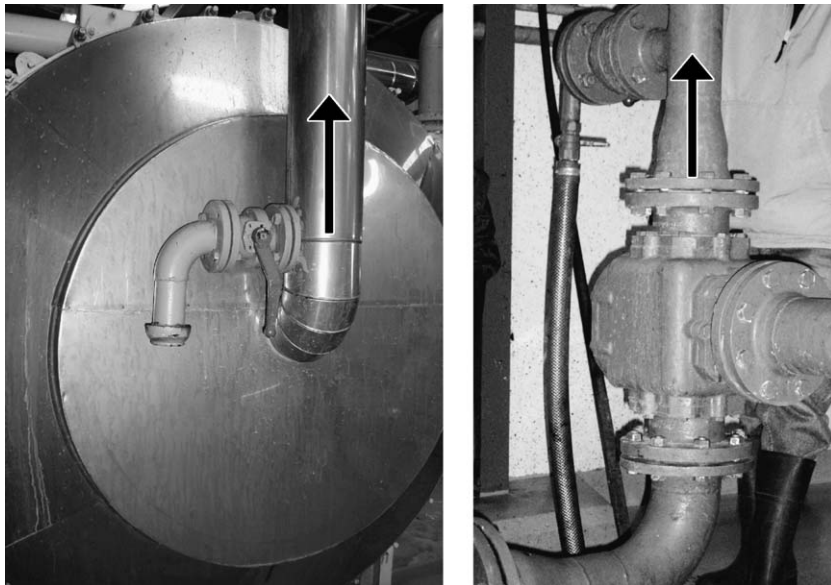

Fig. 2. Primary sampling locations for feedstock and final digestate. Left: outflow from heat-exchanger immediately before inlet to CSTR reactor. Right: sampling of digested biomass at the CSTR reactor outlet. Note sampling only in vertical upward flow.

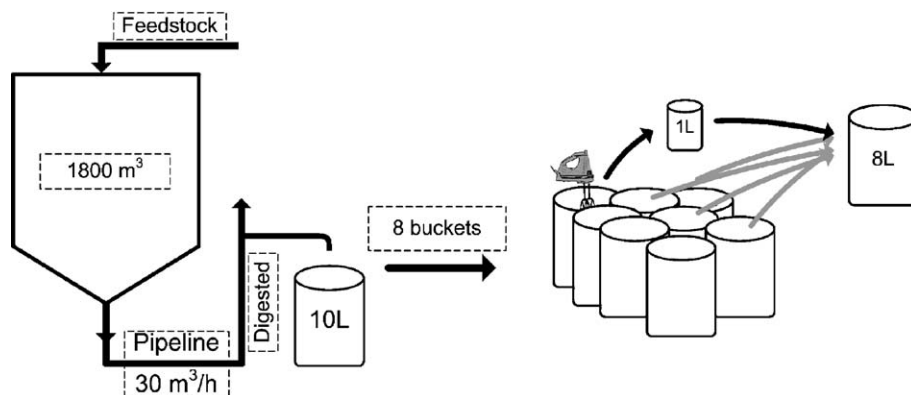

Fig. 3. Schematic illustration of primary sampling at the full-scale biogas plant in which a two-step composite sampling approach was used. Eight 10-L primary increments were individually mass-reduced to 1L, before being compounded. Mechanical agitation is essential to keep the bioslurries in a state of maximum homogenization while being subsampled. This compound sampling scheme is in full accordance with the principles of TOS [5–9].

Feeding and outlet pumping sequences both consist of 30 m<sup>3</sup> biomass/h from an 1800-m<sup>3</sup> biogas reactor. Although the composite sample itself only corresponds to  $(8 \times 10 / 30,000) \times 100 \sim 0.3\%$ , the composite sampling rate covered approximately  $(15 / 1800) \times 100 \sim 0.8\%$  of the total reactor volume in the 30-min pumping interval. Sampling rates of the order of 0.1–1.0% are typical of reactor volumes of the current magnitude (1800+m<sup>3</sup>), for very hardheaded practical reasons (Fig. 3).

The bioslurries were first collected from the outlet pipeline in a series of eight 10-L buckets representing time sampling over 3 min. From each of these 10-L buckets, a 1-L increment was extracted while the content was thoroughly mixed by use of a hand-held mixer to ensure maximum homogenization. The resulting eight 1-L increments were subsequently combined into an intermediate 8-L composite sample, for further secondary sampling.

2.2. Secondary sampling: sample size reduction for the fermentation trials and analysis

From this 8-L composite bucket, secondary sampling increments were extracted using a fractional lading technique: each 750-mL secondary sample consists of 15 such increments,

which were extracted at various depths in the continuously stirred material. Taking many small increments under continuous agitation leads to a minimization of the dominant sampling error involved, the grouping and segregation error (GSE). This secondary sampling scheme is also in accordance with all appropriate principles in TOS [5–9].

This contrasts drastically with, e.g., one 750-mL grab sample taken directly from the pipeline, which would be thoroughly non-representative, *ibid.* Use of such a scheme for direct grab sampling, i.e., going directly for the final sample volume without TOS-correct mass reduction of the a larger composite alternative delineated above completely destroys any hope of representativity. Such direct grab sampling unfortunately more-or-less rules the day in very many routine, ill-reflected sampling protocols.

The final part of the secondary sampling followed a scheme of randomly choosing 750-mL bottles, which were further subdivided into 120-mL volumes. These were even further subdivided into a number of 30-mL volume vials. At each level, mass reduction was carefully performed by similar agitated fractional lading, although using with appropriately scaled-down tools, etc. The entire TOS-correct mass reduction of biomass feedstocks (as well as final digested biomass) resulted in thoroughly representative material utilized for all

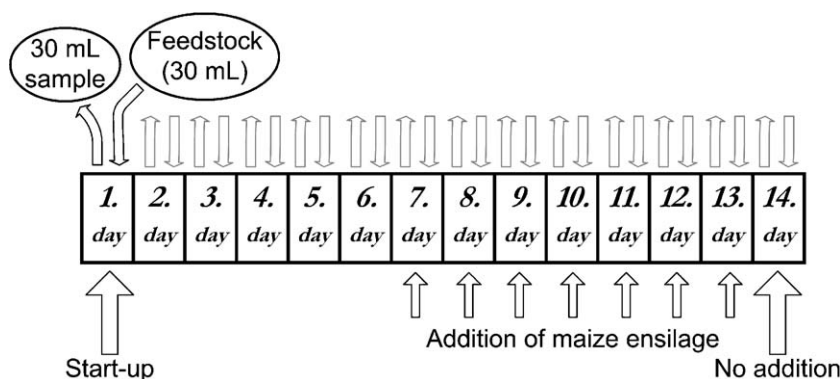

Fig. 4. Fed-batch laboratory reactor operations flowsheet outlining balanced sampling and feeding schemes. Addition of maize ensilage was used to boost biogas production. All 30-mL sampling/30-mL feedstock replacement takes place every sixth hour (four times each day).



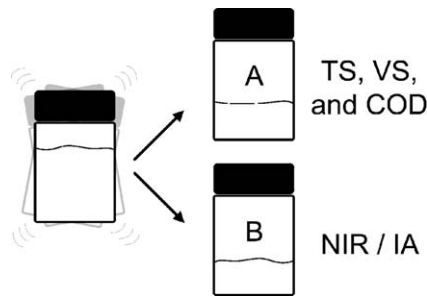

Fig. 5. Schematic illustration of typical laboratory subsampling procedure, here used for chemical reference analysis (subsample A) and NIR/IA (subsample B). *Fractional pouring* (in a composite sampling mode) was used to split the initial sample into two subsamples. Two other alternative subsampling methods in the laboratory were also evaluated, see text.

experimental digestion trials, for chemical reference analysis and for testing the selected PAT tools.

### 2.3. Tertiary sampling from the laboratory reactor

Mixtures for laboratory-scale fermentation trials were formulated as 20% raw feedstock added to 80% the outgoing digested biomass in order to be as identical as possible to the average complex material found in the full-scale fed-batch operated reactors of the biogas plant. In a broad sense, this mixture can be viewed as typical for a great many contemporary AD biogas reactor contents, especially as regards the two-phase bioslurry characteristics.

All anaerobic digestion trials in the laboratory were run for 14 days. After the sixth day, 1% finely macerated maize silage was added daily to increase the dry matter content in the feedstock (Fig. 4). Use of this TS-augmented medium is motivated by new feedstock strategies being contemplated in the European biogas sector focusing more on well-defined feedstocks originating exclusively from farms (in combination with the ubiquitous manure). This study conveniently also uses this total solids (TS) increase to produce a significant calibration span for TS in the multivariate calibration context.

Over the entire 14-day biogas cycle, a 30-mL digested biomass sample was extracted every sixth hour from the laboratory reactor by a syringe device (Fig. 1). This provided all samples used for reference analyses (Y) for both NIR and image analysis X-data. Each 30-mL volume was promptly replaced by an equal amount of fresh feedstock, making the laboratory reactor run in a similar fed-batch mode as its full-scale origin. These 30-mL samples reflect the typical practical difficulties and attendant sampling uncertainties caused in batch-fed or continuously fed reactors—problems typically caused by segregation or sedimentation, inefficient/insufficient steering, inhomogenous fibre distribution a.o.

### 2.4. Quaternary sampling for analysis

Each 30-mL sample was finally split in two by a fractional pouring technique. From each sample, 15 mL was subsampled for reference analysis (subsample A) by vigorous shaking of the vial followed by immediate pouring of a small fraction into

another container. This procedure was repeated several times until approximately 15 mL were obtained as illustrated in Fig. 5; absolutely identical weight was not a critical issue for the subsequent chemical analysis, as different weights were corrected for. The remaining volume constituted the parallel subsample B. This procedure is also meant to represent very many contemporary laboratory techniques as closely as possible.

### 2.5. Analytical procedures

TS, VS and COD were chosen as experimental analytes in this comparative study, since they are typically used to characterize both feedstock and digested biomass in full-scale biogas production contexts. Fig. 6 shows the uncertainties of the reference measurements—calculated as the relative standard deviation (RSD), defined as [20]:

$$\text{RSD} = \frac{s}{x} \cdot 100\%$$

RSD for reference measurement duplicates show twice as high an analytical uncertainty for COD compared to TS and VS. For routine AD monitoring in the industrial regimen, it is customary not to invest in overly accurate nor precise analytical equipment (including sampling equipment and procedures); one is usually content with analytical reproducibilities of the order of, say, 5+, which is not acceptable for pilot study laboratory runs however. For COD, the current total reproducibility standard deviation almost reaches 11%, which is way too high for serious data analysis and interpretation. Nevertheless, for the integrity and practical relevance of the present sampling feasibility study, it was necessary to use this standard industrial COD analytical procedure.

#### 2.5.1. Ultimate subsampling of bioslurries (analytical volume)

A special study was deemed necessary, to determine if—or to what extent—the intrinsic material heterogeneity affects splitting into two supposedly identical subsamples (cf. Fig. 5), because later multivariate calibrations are based on these split sample series (parallel samples producing the X- and Y-data, respectively). Subsample A was poured from the predecessor vial, while subsample B is made up of the remaining material. Thus, if segregation occurs at this ultimate, minute scale-level,

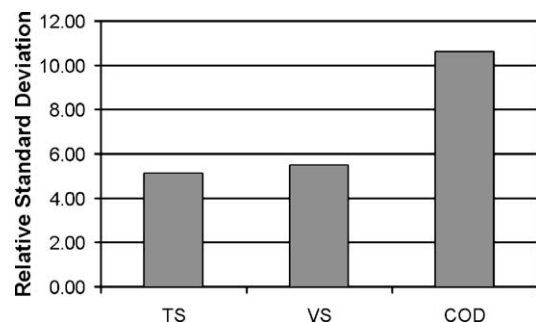

Fig. 6. Relative standard deviation (RSD) for duplicate reference analyses for three selected analytes.

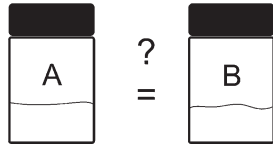

Fig. 7. Analytical volume sample splitting test. Will (50/50) splitting into parallel A and B aliquots by pouring result in two equal subsamples (mass, composition), i.e. to which degree will they be representative of the predecessor sample? Sample A is poured from the predecessor vial, while subsample B contains the remaining material.

subsample B should show a higher concentration level of solid matter, but to what extent—significant or negligible (Fig. 7)?

No less than four different types of relevant heterogeneous materials/mixtures were examined for these splitting experiments. The level of heterogeneity, and hence the magnitude of the resulting sampling error, will depend on the material and its specific characteristics. The following formulations are based on extensive practical experience with AD systems and materials:

- Feedstock (raw material from the Ribe Biogas plant)
- Digested biomass (also from the Ribe Biogas plant)

- FD (20% feedstock, 80% digested biomass)
- FDM (10% feedstock, 88% digested biomass, 2% maize silage)

The first two substrates were chosen for obvious reasons, since they constitute the relevant bracketing (raw material→end-product) of the industrial biogas production process studied. FD has a composition similar to that under initial laboratory bioprocessing conditions, while FDM has strong similarities with important industrial mixtures, which are routinely “improved” by adding maize silage.

These four material substances were each produced in a series of 30 duplicate split vials, each of 30 mL, by fractional lading, following identical procedures as outlined above for secondary sampling (Section 2.1). In the results section, we evaluate the effectiveness and representativity of this replication experiment. Analytical results from the comprehensive splitting tests are visualised in Fig. 8 for TS and VS.

In general, VS shows no difference between A and B samples, while there is a clear systematic difference between A and B samples as concerns TS for all four materials. The total solids content of course reflect the dry matter content, the

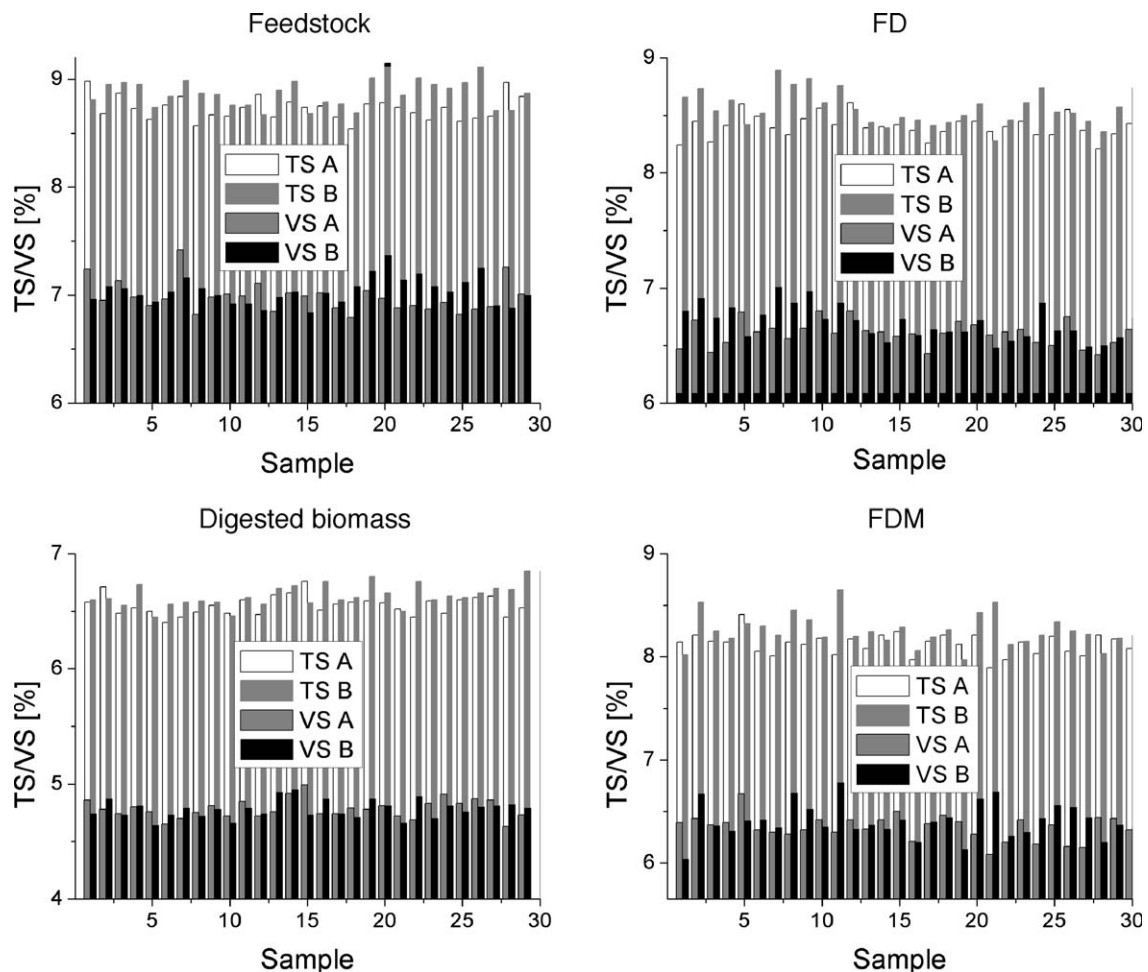

Fig. 8. Compositional differences between A and B vial splits (TS and VS) for four types of materials, typical in biogas production: feedstock, digested biomass, FD and FDM. Note truncated concentration axes, visually augmenting A/B differences. Note a clear systematic difference in TS contents for B samples for all four compositions, while this tendency is missing for VS.



Fig. 9. Equipment used in evaluation of vial-to-Petri dish extraction. Left: “pseudo COLIWASA” (operated manually by thumb-pipetting). Right: cut, standard automated pipette. Note that both these alternatives allow for sampling of “sticky” material following [6].

fraction prone to segregation. Splitting into A and B subsamples by fractional pouring in the current study will consequently be slightly biased. Even the extreme homogenization efforts employed in this study have not been able to do away entirely with this tendency.

## 2.6. Multivariate calibration implications

Since the consecutive 30-mL samples from the fermentation process resulted in relatively minor (but not negligible) differences between the A and B subsamples, some mismatch between reference analysis and NIR/IA was unavoidable. The net effect of this is to broaden the imprecision associated with the final prediction models; everything else equal, a mismatch between the X- and Y-samples will inflate RMSEP levels. But because this feasibility study is aimed at showing the prospects of PAT methodologies on heterogeneous systems, including inherent sampling problems the bias is accepted here (it is far smaller than what is usual from sampling from this type of heterogeneous system). This bias can play a didactic role as to the pervasiveness of *incorrect sampling errors* at even the smallest scales in the total sampling-and-analysis process chain.

### 2.6.1. Vial extraction method

Another subsampling test was carried out to discriminate between three alternative methods for sampling (extraction) from a vial to a Petri dish. Two of the above mixtures were used again:

- DM (90% digested biomass and 10% maize silage).
- FDM (10% feedstock, 88% digested biomass and 2% maize silage).

The following three extraction techniques were investigated:

- “Pseudo Coliwasa”, a plastic tube made from the cut end of an automatic pipette, which allowed large(r) particles to be sampled manually.
- Standard automatic pipette with cut end, also allowing large particles to pass.
- Incremental fractional pouring directly from the vial, with continuous shaking to minimize segregation effects (as described above).

The COLIWASA (ColumN LIquid Water SAMpler), described in detail in [7], is supposed to allow extraction of a virtually undisturbed column through the entire thickness of a possibly stratified medium. This is an especially appealing

approach for segregated materials, since such a column by definition is the only which can be fully representative, *ibid.* Pitard [6] also describes weakly conical inlet tube configurations, which allows effective sampling of “sticky materials” (within “reasonable” limits), as is illustrated in Fig. 9.

All methods were tested with continued agitation of the super-nascent suspensions. These alternative extraction techniques from vial-to-Petri dish are compared in Fig. 10 for the two prepared mixtures DM and FDM, again using the relative standard deviation. RSD is here a measure of the reproducibility of the specific extraction method, based on 10 replicate extractions.

From Fig. 10, all three methods would appear close to equal in extraction performance, with a grand average RSD of some 4.5%. None of the methods are very much different from one another over both materials. This result was slightly surprising, as the COLIWASA approach has otherwise shown great potential in many other macroscopic application scales. The present application is distinctly on the mini-scale however. Fractional pouring, showing a minimum RSD for DM and intermediate for FDM, was chosen as the extraction technique used for analysis by NIR and image analysis below.

## 3. Analysis

### 3.1. NIR measurements—PAT

The specific reflectivity and absorptivity of the complex AD organic materials makes it ideal for analysis by NIR spectroscopy. NIR is also advantageous for on-line characterization due to its often *supposed* minimal or no sample

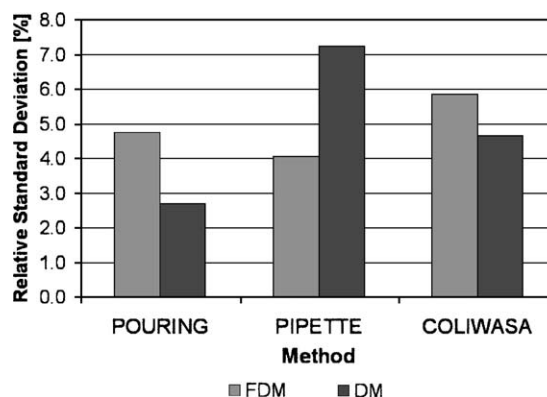

Fig. 10. RSD comparison of reproducibility of alternative vial extraction techniques, based on two different mixtures (FDM, DM). Average results, based on 10 replicate extractions for each technique and biomass material.



Table 1  
NIR prediction evaluations for TS, VS and COD; identical 11-segment X-val

NIR	TS	VS	COD
Slope	0.87	0.90	0.77
$R^2$	0.81	0.91	0.77
Outliers	9	9	7
# Comp	4	3	3

pretreatment and rapid analysis/sample prediction in standard PAT operations [21–26]—which very often pays no attention to the gamut of sampling representativity issues however.

NIR measurements were carried out on the B subsamples (see Fig. 5) using a NIR Systems 5000 spectrophotometer equipped with a mirror transflexive probe head on an optical fiber (scanning range between 1100 and 2500 nm). The samples were homogenized prior to measurements by vigorous shaking. Having completed the NIR measurements, the same samples were subsequently subjected to image analysis.

### 3.1.1. Results—NIR

NIR spectra were modeled using PLS-1 with segmented cross validation for all three Y-variables: TS, VS and COD; Table 1 summarizes these results. The final 44 measurements (objects) were divided into 11 segments, selected from a sorted listing of ascending TS/VS/COD values. For the purpose of comparison *between* alternative prediction models, it is acceptable, indeed optimal, to use an appropriate segmented cross-validation scheme—contrary to the demands for absolute prediction performance assessment, in which the use of an independent test set is mandatory [27].

Fig. 11 (left) presents the loading weights for the first and the second PLS components from a NIR model of the volatile solids, VS. Stochastic noise was dominant for the highest wavelengths, wherefore variable selection was performed, cutting away variables >2300 nm without loss of information—indeed resulting in improved models; there were a relatively high fraction of outliers.

Final assessment of any PLS model rests with the “predicted vs. measured” plot, or rather with the attendant statistics, pertaining to a fitted regression model. A slope of 0.90 or higher

is highly acceptable for the present strongly heterogeneous system. A RMSEP of 0.23 signifies a quite satisfactory prediction precision. Based on the mean VS (4.7%), this RMSEP corresponds to a prediction error  $\sim 10\%$  ( $\pm 2$  RMSEP). Another way to express prediction precision is by the squared correlation coefficient. For the NIR VS model,  $r^2$  scores as high as 0.91. These statistics attest a satisfactory potential for predicting VS directly from (*properly sampled*) at-line samples.

Table 1 shows similar statistics for all three AD process parameters, TS, VS and COD. While TS does not achieve as quite good prediction assessment statistics as do VS, they are still acceptable, but COD cannot be modeled with any degree of satisfaction. COD is a measure of the chemical oxygen demand, which includes all compounds in the sample, including water-soluble molecules a.o. It is not overly surprising that no correlated signals appear in the NIR spectra. This can partly also be explained by the particularly high analytical uncertainties for COD compared to TS and VS (see Fig. 6).

### 3.2. Image analysis

An at-line image of the surface of a specially prepared version of the “B” samples is acquired by an appropriate imaging system in the laboratory, which has been described extensively in [18,19]. This type of imagery is isotropic for which reason the AMT transform can be put into use [14–19].

The angle measure technique (AMT) is a preprocessing technique used for characterizing the complexity of one- and two-dimensional technological data series [14–18]. Image analysis (IA), combined with AMT and PLS-R, is a powerful technique for qualitative and quantitative description of visual features, especially surface morphology and texture [15]. This combined imaging technique (IA/AMT) has mostly been used for characterizing solid materials (surface textural features) and bulk materials (particle sizes, shapes a.o.) [14–19]. The current study takes this technique into a new domain, into characterization of the visual appearances of complex slurry textures as presented by Petri dish appearances in a backlighted setting [18,19]. This may have potential interest in pulp-based industries of various kinds (dairy, paper, mineral extraction,

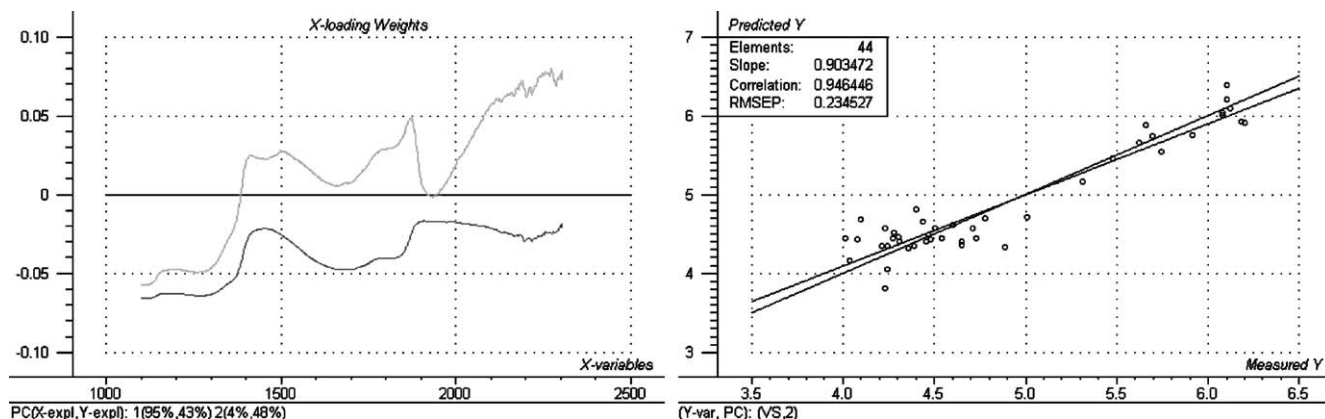

Fig. 11. Left: loading weights for the first and second PLS components for a NIR model of the volatile solids, VS. An indication of the >2300-nm stochastic noise can be appreciated, especially for the second (topmost) component. Right: predicted vs. measured plot for this model, based on 11-segment cross-validation.

chemical process industries), which was the reason to include image analysis/AMT as a possible PAT modality here.

From the outset, it was expected that IA/AMT should be able to model, e.g., TS effectively, while the attendant VS (and COD) might, or might not, also be amendable to PLS modeling and prediction as well. This will depend on the closed array stoichiometrics of the anaerobic digestion system: In a compositionally closed system, it may sometimes be possible to arrive at satisfactory prediction facilities based on *indirect* characterization, necessarily heavily dependent upon realistic test-set validations, etc. [27].

The AMT algorithm was originally developed for one-dimensional data and cannot process a color image as such (in this study R/G/B imagery is used). Each color channel must hence be tested separately, which—in turn—results in three AMT complexity spectra; one for each color channel. The AMT method has been described in full detail in the chemometric literature [15–19].

The imaging system was a QImaging filter-wheel CCD camera equipped with a Nikkor 120mm F2.8 macro lens, supporting 12-bit grayscale images with a resolution of  $1280 \times 1024$  pixels. A  $4'' \times 4.88''$  backlight platform from Schott Fostec was used to illuminate the material being imaged. Backlighting can be used to create a crisp edge around the present solid material particles in transparent liquids (water). This was thought to be especially useful for image complexity characterization with AMT, because the algorithm would benefit from a clear definition of the transition between matrix (water) and object (dry matter particles).

### 3.2.1. Replication scheme in image analysis

Each final 30-mL B subsample was distributed into two Petri dishes by fractional pouring as related in detail above. Two non-overlapping images from each Petri dish subsample were acquired. Subsequently, the Petri dish was gently shaken (*not stirred*) and another set of images was acquired. This procedure was repeated four times, resulting in eight replicates for each split subsample—altogether 16 replicate images for each B subsample (Fig. 12). The rationale for this extensive

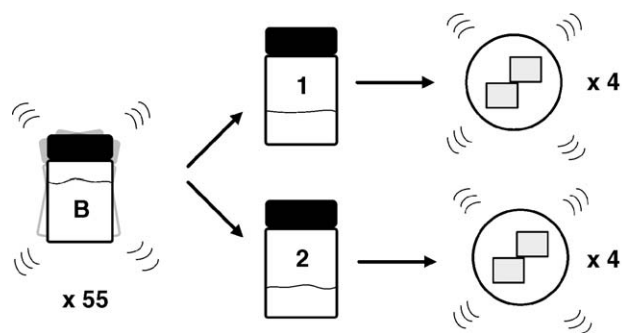

Fig. 12. Replication protocol for imaging procedure. Subsamples (B), also used for NIR analysis, are mixed thoroughly before being distributed into two subsamples (termed 1 and 2) by fractional pouring. Each subsample is poured into a Petri dish and subjected to duplicate imaging. This is followed by gentle shaking of the Petri dish four times with duplicate images after every redistribution of the sample. Altogether this results in an extensive  $2 \times 8$  replicate image series for each B sample.

replication relates to the need for evaluating the camera-presentation sampling variance, essentially the “pouring variance”, which will always be present for an at-line imaging system. This pouring sampling error cannot be ignored a priori; it has never been adequately assessed [5–7]. In addition, the material is still exceedingly heterogeneous at this stage; the more image replicates, presumably the more representative their average manifestation. This procedure was repeated for each of the 55 samples drawn from the entire 14-day fermentation cycle. The complete imaging procedure is illustrated in Fig. 12.

### 3.2.2. Results—IA

All images were processed using AMT using both MA as well as MDY complexity spectra [15–19]. Subsequently, all images were subjected to a correction procedure (gamma correction and grey-level enhancement) to optimize image contrast in order to obtain the best possible AMT definition. All images were treated identically. These images were all transformed into AMT complexity spectra and were subsequently modeled using PLS-1 with *identical* segmented cross-validation procedures as for the validation of the NIR models.

The loading weights from this PLS model reflect the wavelengths, which are most correlated with VS. The MA spectra (left half of MA + MDY) reveal that neighbourhoods up to a distance of some 35–85 pixels carry the main correlated information. This corresponds well with the pixel size/resolution of typical dry matter particles in the original images. The main contributions to the prediction model come from the first and second PLS components (92/58 and 6/15% of the total X/Y-variances modeled, respectively).

The prediction assessment in Fig. 13 shows only a slightly lower prediction precision ( $r^2=0.88$ ) for TS than for VS. The accuracy statistic slope is equal to 0.86, which again is fully acceptable for the complex system involved. Because of essential interconnections, the relative RMSEP-level is also closely comparable.

Fig. 14 shows the same predicted vs. measured relationship for the VS model as in Fig. 13, also showing models based on all 16 individual replicates, a model based on averaging of the image duplicates and a model based on averaging both image duplicates and shaking replicates. Fig. 14 very clearly attests to the enormous advantage of the averaging operator in the presence of the significant variability associated with the imaging sampling process.

The most important feature in Fig. 14 is the enormous sampling error associated with the original pouring into a Petri dish, viz. the extremely large individual differences in the 16 replicates for each split (upper left panel). This is a poignant reminder that sampling errors (sampling variability) can, and will, crop out at any scale if not recognized; from the primary field situation to the last instance of pouring some 15, apparently innocent, milliliters into a Petri dish (very often considered totally “insignificant” in the greater order of things). The lesson is clear though. If the attending sampling variability is not known, there is every chance that unrecognized errors of

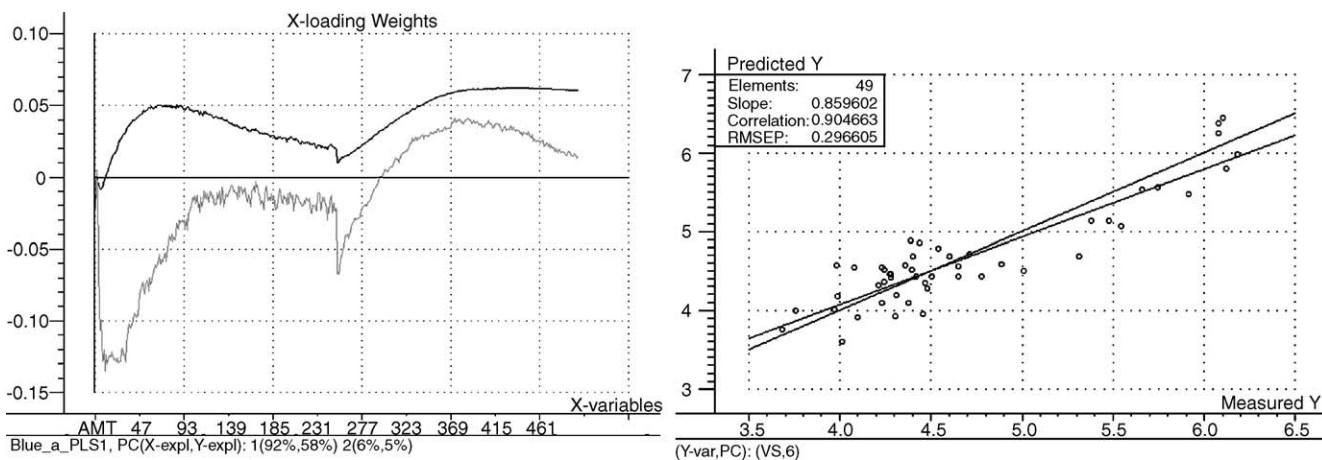

Fig. 13. Evaluation of image analysis PLS-1 model for VS. Left: loading weights for the first and second components. No variable selection was needed for AMT. The model is based on corrected images (described in text) from the blue channel. Right: predicted vs. measured plot for the AMT model of VS, based on a grand average of all 16 image-replicates (Fig. 14 shows the same results *without* averaging).

highly detrimental magnitudes may easily corrupt the reliability of the analytical results. It is only through the diligent, extremely careful, replication/averaging scheme employed in the present study that any image analysis/AMT prediction model could be obtained at all (lower right panel).

Table 2 summarizes averaged results from the whole set of image analysis calibrations, based on the red, green or blue image channel, respectively.

From Table 2, it can be seen that acceptable prediction models are possible for both TS and VS for all three channels. In

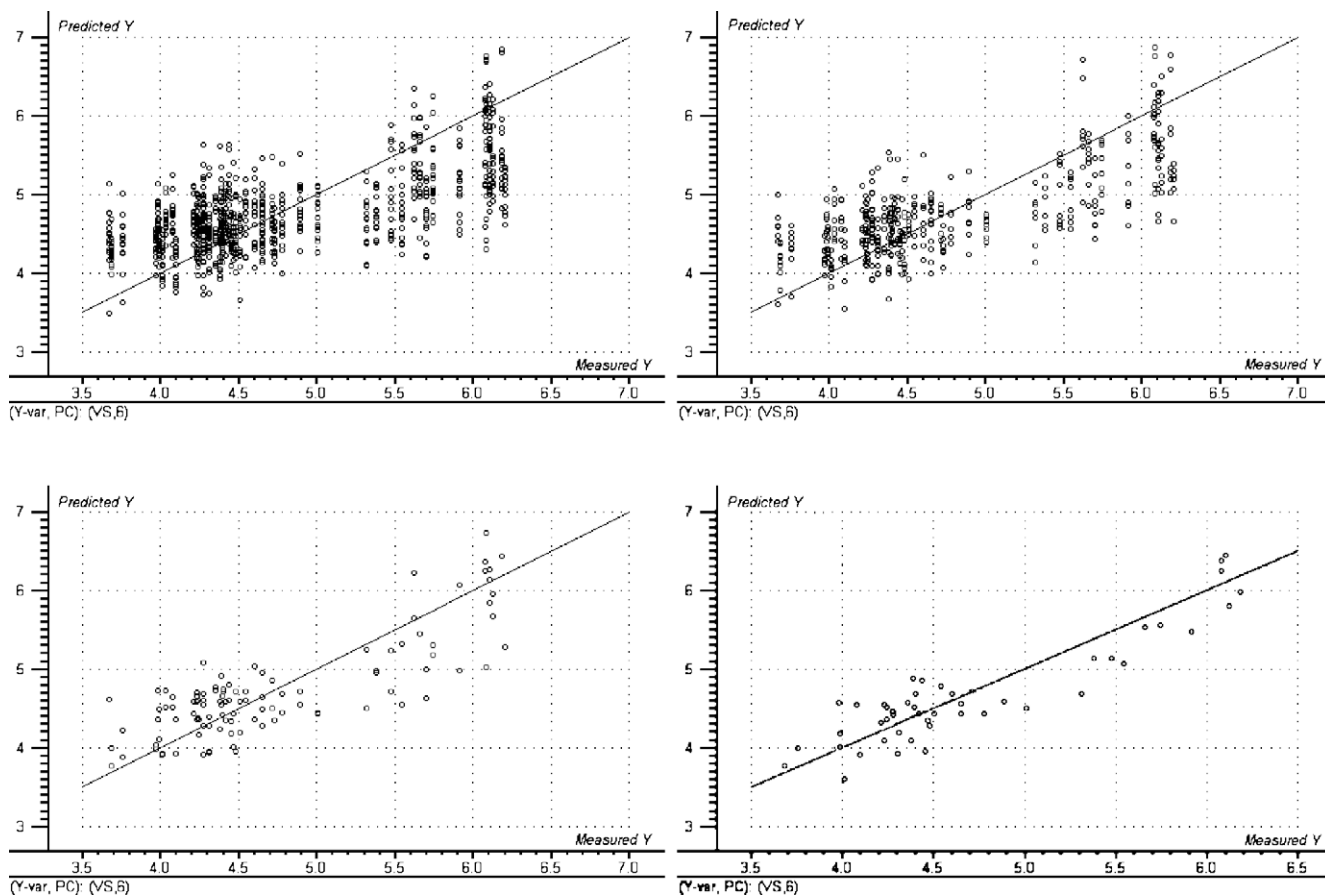

Fig. 14. Averaging effect on the “predicted vs. measured plot” for the PLS-1 model of IA/AMT for VS. Top left: model without averaging (880 images). Top right: model with averaging over image duplicates (440 images). Bottom left: averaging of image duplicates and shaking replicates (110 images). Bottom right: final model based on all three levels of averaging.

Table 2  
PLS prediction results for TS, VS and COD from IA/AMT on three alternative color channels

IA results		TS			VS			COD		
		Red	Green	Blue	Red	Green	Blue	Red	Green	Blue
Original images	Slope	0.77	0.72	0.84	0.84	0.79	0.80	0.67	0.63	0.71
	$r^2$	0.72	0.66	0.76	0.81	0.76	0.79	0.64	0.64	0.67
	Outliers	6	5	6	6	6	7	7	6	8
	# Comp	5	5	6	4	3	1	3	3	5
Corrected image	Slope	0.70	0.73	0.78	0.73	0.71	0.86	0.53	0.53	0.51
	$r^2$	0.59	0.71	0.72	0.66	0.67	0.81	0.50	0.50	0.49
	Outliers	6	8	4	6	4	6	5	6	6
	# Comp	5	5	5	4	5	6	2	2	3

The images were modeled both with and without a contrast enhancement (original vs. corrected images).

general, the models were not improved from the contrast correction however. The blue color channel would appear to give the best prediction models on an overall basis, though the red channel works well also for VS. It is not possible to model COD by any image approach. The computationally intensive image correction should be omitted, since this does not improve the predictability.

## 4. Discussion and perspectives

### 4.1. Representative sampling—a must

This study illustrates the importance of a fundamental quantitative heterogeneity characterization for all new materials to be sampled for the first time [8]. Considerable efforts were spent on zooming in on appropriate sampling procedures, from the initial field sampling to the minute sampling for the ultimate analytical volume. A considerable informed diligence with relation to TOS is necessary in order not to oversee any link in the sampling vs. scale representativity hierarchy. The innate heterogeneity of the material systems were highly significant, which made for an exceptionally clear case of the difficulties involved in representative sampling and mass reduction. There exist a plethora of identical complex, heterogeneous materials in process industrial sectors to which the chemometrics community currently introduces the PAT concept. Reliable, representative sampling must play a central role in this context, in the critical reference calibration context as well as concerning appropriate sensor localizations and representativity in accordance with the entire volume or cross-section of reactors or pipelines.

### 4.2. NIR and image analysis perspectives

This feasibility study tested a parallel NIR and AMT methodology for characterizing specific complex, heterogeneous bioslurries (sampling based on proper TOS principles). Optimization of the individual experimental conditions will necessarily be closely linked to the particular industrial implementations. Many parameters, such as illumination and camera options, sample preparation (especially dilution and sample amount/thickness) and bioslurry sampling must always be optimized when dealing with image analytical applications,

but this will necessarily be related to potential, specific industrial implementations. With problem-dependent optimization, both the NIR and IA prediction models can most likely be somewhat to significantly improved. Below, we discuss general features only.

From related research on newly developed circulation flow-through cells (carried out at Christian-Albrecht's-University, Kiel), termed "Transflexive Embedded Near InfraRed Sensor" (TENIRS), joint work in progress has shown very promising results for the same types of difficult medias. Here, manure slurries and digestate slurries not only gave good models for TS and VS, but also for total-N, ammonium and phosphorous. In this type of circulation configuration, much larger analytical volumes of slurry can be measured in an at-line, or even on-line NIR context. This system is currently for use distinctly as an at-line facility, but by-pass options from primary biogas plant pipelines or reactors can easily be envisaged and are not technically difficult. By-pass solutions must of course also oblige all the necessary TOS criteria.

The challenge is to develop, and especially to maintain, robust calibration models based on NIR measurements, due to the extreme variability of the feedstocks encountered in the industrial biogas sectors originating from a bewildering array of manure types and organic by-products as well as waste-streams from food and pharmaceutical industries. There is an ultimate challenge due to the fact that systems have to be developed, and maintained, at price levels far below what is the case for, e.g., the food manufacturing and pharmaceutical sectors. This is because the bioenergy sector has to produce, indeed make a profit, far below these price levels per units of product [3,4]. This puts very stringent demands as to the level of high-tech equipment that can be contemplated.

### 4.3. PAT for anaerobic bioconversion processes—perspectives

The present method developments in laboratory-scale studies are currently being followed up by extensive testing of the TENIRS flow-through cell system both for at-line and on-line NIR, augmented by acoustic chemometrics characterizations [28,29], aimed at overcoming the immense difficulties for TOS-correct reactor sampling, which is virtually impossible. This will be done by introducing a *recurrent loop* sampling concept, essentially transforming the three-



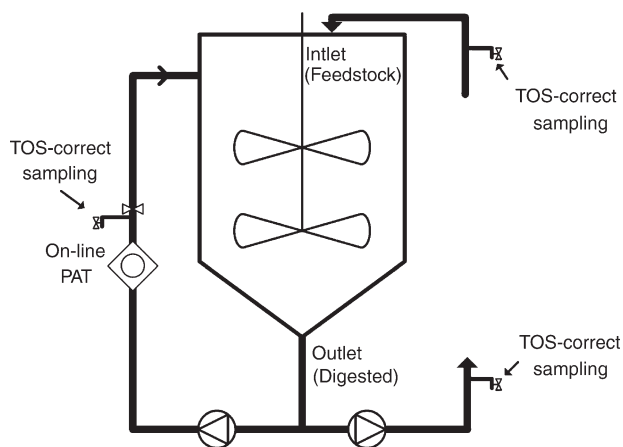

Fig. 15. On-line PAT measurement and TOS-sampling concept in a full-scale AD plant context.

dimensional bioreactor sampling issue into a one-dimensional pipeline sampling situation, which in comparison is fairly easy [8,9]. The prospects here also lie in reducing and minimizing the time consumption and cost expenditures for the necessary analysis.

PAT, process analytical technologies is here, as in pharmaceutical and food production contexts, directly aimed at improved process control by applying suitable sensor technologies for on-line measurement of biomass feedstock composition and of important intermediary and end products of the anaerobic digestion processes. Appropriate sensors and physical sampling modalities shall be deployed at critical control points: (1) at raw materials and feeding inlet/outlet localizations, (2) in recurrent loops positioned strategically in the process and (3) at post-treatment localizations. These developments will contribute towards the goal of an integrated process and product monitoring management and regulation system, orders of magnitude more reliable than the current state of art.

By introducing the type of *reliable* on-line PAT sensor systems delineated in Fig. 15 in addition to the at-line analysis approaches surveyed here, it will be possible to deliver fully comprehensive monitoring data for improved control throughout the AD processes. This will make it possible to adjust process parameters on a real-time basis based only on characterization of feedstock variations coupled with a library of relevant PLS predictor models. This concept transgresses the narrow AD scope and will address the much more general field of anaerobic bioconversion (ABC) process regimen without loss of significant carry-over potential because of the consciously selected adverse general dry-matter/suspension characteristics in the present study.

## 5. Conclusions

A down-scaled laboratory bioreactor was used to survey appropriate sampling for two selected potential process analytical technologies, NIR and image analysis/AMT, for highly heterogeneous anaerobic digestion processes in large-scale biogas plants.

Table 3  
NIR modeling/prediction results

NIR	NIR		
	TS	VS	COD
Slope	0.87	0.90	0.77
$R^2$	0.81	0.91	0.77

All critical sampling issues for at-line analysis across the relevant scale domains, primary sampling, reactor and pipeline sampling, secondary laboratory sample mass reduction, tertiary mass reduction/splitting in the laboratory trials and quaternary NIR/IA analytical sample preparation, were analyzed in their proper TOS contexts. Appropriate representative sampling procedures and equipment were developed and implemented, commensurate with the intrinsic heterogeneity characteristics of the materials involved, as exemplified by multicomponent organic feedstocks and digested bioslurries. An attempt was made to illuminate the critical role of proper quantitative heterogeneity characterization before design of representative sampling protocols, without which chemical analysis and data analysis will always be in potential jeopardy.

The quantitative sampling\_cum\_analysis error levels involved were empirically estimated in order to demonstrate the effectiveness of the sampling measures adopted. Each of 55 laboratory reactor samples following the normal and enhanced (maize silage spiking) biogas process development was split into two subsamples by use of optimised fractional pouring. One of these subsample series was subjected to NIR followed by image analysis/AMT, while the other was used for chemical reference analysis of total solids (TS), volatile solids (VS) and chemical oxygen demand (COD), followed by multivariate calibration (PLS regression).

Acceptable prediction models could be obtained for TS and VS for both the NIR and IA/AMT techniques, as summarized in Tables 3 and 4. These two important routine AD parameters show promising prospects for at-line/on-line prediction of complex bioslurries, while it was not possible to model COD satisfactory due to very large analytical uncertainties in the routine COD analysis standards. This latter aspect both can and will have to be improved.

There would appear to be a significant advantage in using a larger primary camera footprint—in the form of many image replicates in order to suppress the specific image sampling errors encountered, dramatically displayed by Fig. 14. While we here were able to suppress this error satisfactory (by extensive replication), if image analysis indeed is to be a viable PAT candidate for this type of material system, it must be amendable

Table 4  
IA/AMT prediction results (blue channel)

IA	Original image—blue color channel		
	TS	VS	COD
Slope	0.84	0.80	0.71
$R^2$	0.76	0.79	0.67

to extensive automated sample preparation (presentation to the camera)—which is tantamount to a far too laborious, and even more too expensive, task for full-scale facilities at present.

Thus, the NIR approach comes out as a clear winner in this context, especially as the prospects for full-scale implementation already has been amply proven for many other media in very many other process analytical contexts. While the critical (although often too easily dismissed) sampling issues have been treated in full detail here, the attending specific probe-localization sampling error issues have been only hinted at so far however; they will be addressed in full elsewhere.

## Acknowledgements

Baseline sampling and NIR studies were carried out by an enthusiastic complement of our Romanian and Polish 8th semester MSc (Eng.) students at Aalborg University Esbjerg: Monika Antczak, Liliana Jensen and Adam Stachowski, to whom we extend our sincere thanks for their hard work. They and their fellow students achieved a good learning process about TOS and NIR.

## References

- [1] Å. Nordberg, M. Hansson, I. Sundh, E. Nordkvist, H. Carlsson, B. Mathisen, Monitoring of biogas using electronic gas sensors and near-infrared spectroscopy (NIR), *Water Science and Technology* 41 (2000) 1–8.
- [2] B.K. Ahring, M. Sandberg, I. Angelidaki, Volatile fatty acids as indicators of process imbalance in anaerobic digestors, *Applied Microbiology and Biotechnology* 43 (1995) 559–565.
- [3] K.H. Gregersen, Centralised Biogas Plants—Integrated Energy Production, Waste Treatment and Nutrient Redistribution Facilities, 2005 (11 Feb.). <http://websrv5.sdu.dk/bio/pdf/centra.pdf>.
- [4] T. Al Seadi, Danish Centralised Biogas Plants—Plant Descriptions, 2005 (11 Feb.). <http://websrv5.sdu.dk/bio/pdf/rap2.pdf>.
- [5] P. Gy, *Sampling for Analytical Purposes*, John Wiley and Sons, 1996.
- [6] F.F. Pitard, *Pierre Gy's Sampling Theory and Sampling Practice*, 2 edn. CRC Press Ltd., 1993.
- [7] P.L. Smith, *A Primer for Sampling Solids, Liquids, and Gases*, Siam, 2001.
- [8] L. Petersen, P. Minkinen, K.H. Esbensen, Representative sampling for reliable data analysis: theory of sampling, *Chemometrics and Intelligent Laboratory Systems* 77 (2005) 261–277.
- [9] L. Petersen, C.K. Dahl, K.H. Esbensen, Representative mass reduction in sampling—a critical survey of techniques and hardware, *Chemometrics and Intelligent Laboratory Systems* 74 (2004) 95–114.
- [10] M. Hansson, Å. Nordberg, B. Mathisen, On-line monitoring during anaerobic treatment of municipal solid waste, *Water Science and Technology* 48 (2003) 9–13.
- [11] P.F. Pind, I. Angelidaki, B.K. Ahring, A new VFA sensor technique for anaerobic reactor system, *Biotechnology and Bioengineering* 82 (2003) 54–61.
- [12] A. Legin, Y. Rudnitskaya, C. Vlasov, E. Di Natale, A. Mazzone, Application of electronic tongue for quality and quantitative analysis of complex liquid media, *Sensors and Actuators. B, Chemical* 65 (2000) 232–234.
- [13] A. Legin, D. Kirsanov, B. Seleznev, A. Rudnitskaya, J.B. Holm-Nielsen, K.H. Esbensen, Y. Vlasov, Analysis of feedstuff from biogas production plant by the electronic tongue. The 10th International Symposium on Olfaction and Electronic Nose, ISBN 9984-18-222-3.
- [14] R. Andrieu, The angle measure technique: a new method for characterizing the complexity of geomorphic lines, *Mathematical Geology* 26 (1994) 83–97.
- [15] K.H. Esbensen, K.H. Hjelmén, K. Kvaal, The AMT approach in chemometrics—first forays, *Journal of Chemometrics* 10 (1996) 569–590.
- [16] J. Huang, K.H. Esbensen, Applications of angle measure technique (AMT) in image analysis: Part I. A new methodology for in situ powder characterization, *Chemometrics and Intelligent Laboratory Systems* 54 (2000) 1–19.
- [17] J. Huang, K.H. Esbensen, Applications of AMT (angle measure technique) in image analysis: Part II. Prediction of powder functional properties and mixing components using multivariate AMT regression (MAR), *Chemometrics and Intelligent Laboratory Systems* 57 (2001) 37–56.
- [18] C.K. Dahl, L. Petersen, K.H. Esbensen, Automatic image analytical characterization of powder agglomeration by AMT-regression (angle measure technique): Part 1. Development and validation of method, *Journal of Powder Technology* (submitted for publication).
- [19] C.K. Dahl, K.H. Esbensen, Image analytical determination of particle size distribution for bulk solids, *Chemometrics and Intelligent Laboratory Systems* (submitted for publication).
- [20] D.A. Skoog, J.F. Holler, D.M. West, *Fundamentals of Analytical Chemistry*, 7 edn. Harcourt Brace College Publishers, 2005.
- [21] D.F. Malley, L. Yesmin, R.G. Eilers, Rapid analysis of Hog manure and manure amended soils using near-infrared spectroscopy, *Soil Science Society of America Journal* 66 (2002) 1677–1686.
- [22] A. Millmier, J. Lorimor, C.H. Fulhage, J. Hattey, H. Zhang, Near-infrared sensing of manure nutrients, *American Society of Agricultural Engineers* 43 (2000) 903–908.
- [23] Y. Zhang, Z. Zhang, N. Sugiura, T. Maekawa, Monitoring of methanogen density using near-infrared spectroscopy, *Biomass & Bioenergy* 22 (2002) 489–495.
- [24] P. Jørgensen, J.G. Pedersen, E.P. Jensen, K.H. Esbensen, On-line batch fermentation process monitoring (NIR)—introducing ‘biological process time’, *Journal of Chemometrics* 18 (2004) 81–91.
- [25] Y. Li, C.W. Brown, F.-M. Sun, J.W. McCrady, R.W. Traxler, Non-invasive fermentation analysis using an artificial neural network algorithm for processing near infrared spectra, *Journal of Near Infrared Spectroscopy* 7 (1999) 101–108.
- [26] S. Vaidyanathan, S.A. Arnold, L. Matheson, P. Mohan, B. McNeil, L.M. Harvey, Assessment of near-infrared spectral information for rapid monitoring of bioprocess quality, *Biotechnology and Bioengineering* 74 (2001) 376–388.
- [27] K.H. Esbensen, *Multivariate Data Analysis—In Practice*, 5th edn., CAMO ASA, 2002.
- [28] K.H. Esbensen, M. Halstensen, T.T. Lied, A. Saudland, J. Svalestuen, S. de Silva, B. Hope, Acoustic chemometrics—from noise to information, *Chemometrics and Intelligent Laboratory Systems* 44 (1998) 61–76.
- [29] K.H. Esbensen, B. Hope, T.T. Lied, M. Halstensen, T. Gravermoen, K. Sundberg, Acoustic chemometrics for fluid flow quantifications: II. A small constriction will go a long way, *Journal of Chemometrics* 13 (1999) 209–236.



# Paper II

Jens Bo Holm-Nielsen, Helga Andree, Harald Lindorfer, Kim H. Esbensen

*Transreflexive embedded near infrared monitoring of key process intermediates in anaerobic digestion/biogas production*

Journal of Near Infrared Spectroscopy  
Volume 15, pp. 123-135, 2007

DOI: 10.1255/j.nirs.719





# Transflexive embedded near infrared monitoring for key process intermediates in anaerobic digestion/biogas production

Jens Bo Holm-Nielsen,<sup>a,\*</sup> Helga Andree,<sup>b</sup> Harald Lindorfer<sup>c</sup> and Kim H. Esbensen<sup>a</sup>

<sup>a</sup>ACABS Research Group, Esbjerg Institute of Technology, Aalborg University, Niels Bohrs Vej 8, 6700 Esbjerg, Denmark.

E-mail: [jhn@aaue.dk](mailto:jhn@aaue.dk)

<sup>b</sup>Institute of Agricultural Process Engineering, University of Kiel, Germany

<sup>c</sup>Institute for Environmental Biotechnology, Department for Agrobiotechnology (IFA), University of Natural Resources and Applied Life Sciences, Vienna, Austria

**This work reports an off-line method development simulating at-line anaerobic co-digestion process monitoring using a new transflexive embedded near infrared sensor (TENIRS) system as a process analytical chemistry (PAC) facility. The operative focus is on optimising anaerobic digestion biogas production with energy crops as the main feedstock. Results show that several key monitoring intermediates in the anaerobic fermentation process can be quantified directly using near infrared spectroscopy with good results, especially ammonium and total volatile fatty acids. Good feasibility study prediction validations have been obtained for total solids (TS), volatile solids (VS), ammonium, acetic acid and total volatile fatty acids. The TENIRS system is a new option for real-time, at-line/on-line monitoring of biogas fermentation operations, offering a robust, low-budget PAC approach to a rapidly growing bulk volume industry.**

*Keywords:* anaerobic digestion, biogas production, volatile solids, volatile fatty acids, ammonium, NIR, PAC, TENIRS, multivariate calibration, PLS regression

## Introduction

Near infrared (NIR) spectroscopy is a desirable process analytical technology for monitoring anaerobic digestion (AD) processes.<sup>1–3</sup> Volatile fatty acids (VFA) are the most important organic acid intermediates in the degradation of several heterogeneous, complex organic substances, ultimately producing biogas, which typically consists of 60–70% methane and 30–40% carbon dioxide. AD processes are sensitive to hydraulic or organic overloading due to imbalanced or insufficiently controlled feeding.<sup>4</sup> Following a well-managed feeding strategy, AD processes are characterised by low VFA concentrations (500 mg L<sup>-1</sup>–3000 mg L<sup>-1</sup>), whereas during AD imbalances, VFA can increase exponentially well above 3000 mg L<sup>-1</sup>. Many investigations point to the fact that relatively high VFA concentration in anaerobic digestion processing plants may not be directly toxic to the process but, **instead, will not create sufficient conditions necessary for the production of operative anaerobic digestion bacteria cultures.**<sup>5,6</sup> Additionally, due to the lack of appropriate monitoring and/or managing by poor

controlling, the AD process can slow down, be severely disturbed or, at worst, even break down completely, due to imbalances in VFA concentrations at such inhibitory high levels. Reliable and affordable VFA monitoring facilities are in high demand by the biogas industry sector. Another reason for breakdown could be that the feedstock composition is too high in total nitrogen due to the conversion of proteins and amino acids into ammonium. This often creates low C/N ratios for the AD process. Biological processes need a balanced C/N ratio of 25–35 to run properly. Many types of biomass, for example, bio-slurries from current European farming systems, specifically pig manure types, have a very low C/N ratio as do other types of protein-rich industrial organic wastes.<sup>7</sup> Co-digestion of heterogeneous feedstocks is the case in many modern biogas systems and this also demands new process monitoring and management tools.

The present objective is to develop process analytical chemistry (PAC) technologies that can monitor and optimise the AD process, on-line or at-line, to control highly valuable parameters such as VFA content, ammonia content, total

solids (TS), volatile solids (VS), ammonium ( $\text{NH}_4^+$ ), total-N, total-C or other important process parameters that can be correlated to NIR spectral signals. The transflexive embedded NIR sensor (TENIRS) system is a new at-line and a potential on-line measurement system that fulfils most requirements for the PAC application demands outlined above. This analytical system was recently developed by the Institute of Agricultural Process Engineering (ILV), University of Kiel, for bio-slurry and manure applications in a pig fattening project.<sup>8</sup> It was documented that NIR spectroscopy can be a highly valuable tool for at-line and on-line measurements of the complex composition of bio-slurries during biological conversion processes. With at-line measurement of the chemical composition of manure, the TENIRS system was able to document that the fattening of pigs was related to the animal digestion process as well as the specifics of various pre-feeding processes and to the composition of the different feedstocks involved.

The primary objective of the present work was to assess NIR spectroscopy as a monitoring facility to replace chemical analysis of TS, VS, total-N,  $\text{NH}_4^+$  and VFA for monitoring the anaerobic digestion process. These are five of the most important AD process parameters. NIR spectroscopy is well-proven as a powerful sensor tool for qualitative and quantitative analysis of organic and inorganic compounds, specifically in food and feedstock science but also in many other sectors.<sup>9</sup> Our aims were, initially, to develop tools for at-line and, ultimately, for on-line applications in general for fermentation processes intended for use in agricultural and agro-industrial production, as bio-energy fermentation processing will increase rapidly in the coming decades.<sup>10</sup> Examples of this are food processing, pharmaceutical production and in bio-energy and bio-fuel fermentation applications.



Figure 1. Reidling biogas plant. Fermenter No. 1, flat-roofed fermenter in extreme left field of view, has been in full operation as the main fermenter for one year. In the centre part of the photo is Reidling fermenter No. 2, which was set in operation in February 2005. Photo JBHN, 03/05-2005

## Materials and methods

### Sampling of the primary reactor system

The two experimental locations were the Rohkraft biogas installation, Reidling and the Öko Energie Strem biogas plant, Strem, both in Austria (Figures 1 and 2). These locations were selected in accordance and co-operation with IFA-Tulln,<sup>3</sup> the Environmental Biotechnological Department of The University of Natural Resources and Applied Life Sciences, Vienna. Primary sampling was established on a weekly basis for almost one year as part of the renewable energy network project (reNet-project) in Austria. Additionally, a daily sampling procedure was set up for three to four weeks. The present study was able to piggy-back the reNet project with many advantages and one major disadvantage, the primary sampling, see below.

Primary samples were collected at outlet valves on the vertical sidewall of the full-scale fermenters shown in Figure 1. The fermenters were continuously stirred, which was the only precaution in place for realising a “homogenous fermentation broth” throughout the entire 1000 m<sup>3</sup> fermenter volume. From the Theory of Sampling (TOS), this primary sampling procedure, resulting in samples of 8–10 L of bio-slurry, can not necessarily be considered representative, indeed, almost certainly not.<sup>11,12</sup> The utilisation of a standard valve directly on the sidewall of the bioreactor is structurally incorrect,<sup>13,14</sup> but was the only option available as the primary sampling in this study relied critically on the context of the reNet project. In order to be fully TOS representative, an appropriate sampling procedure could be a vertical recurrent

---

*“Institute for Environmental Biotechnology, Department for Agrobiotechnology (IFA).*



Figure 2. Fermenter No. 2 at Strem biogas plant. Insulation was not completed because this mesophilic fermentation process generated a surplus of heat surpassing that needed for keeping the process temperature constant. Inoculum at this biogas plant was cow manure but, after start-up, the feedstock was almost exclusively maize silage. Photo JBHN, 03/05-2005.

loop concept.<sup>10,11</sup> From such an external loop, pumping from the bottom of the reactor to the top, a full cross-section of the upward flow could have been achieved as a composite sample using as many increments as deemed necessary by a heterogeneity study. This set-up would ensure an optimal ability to represent the entire volume of the fermenter. Structural correctness means that all parts of the lot material have an equal probability of being selected in the sampling procedure. This can obviously never be the case when samples are extracted from the side of a bioreactor.<sup>11,12,15</sup> Also, an in-line sensor, mounted directly on the side of the bioreactor, would not overcome these representative problems, nor extract a representative reference sample for calibrating any PAC sensors.

Even though it was mandatory to make use of the samples obtained using the sub-optimal primary sampling scheme in this study, these problems were not considered to be fatal: The key issue here is that 1 L secondary samples were used for both the NIR (*X*) and the reference (*Y*) data in the chemometric multivariate calibrations to be developed below. This allowed a general assessment of the new TENIRS application potential to be carried out without being crippled by the primary sampling uncertainties described; an identical situation was recently described in an industrial aerobic fermentation setting.<sup>11</sup>

Forty-two primary samples were obtained at the Rohkraft Biogas plant during March and April, 2005, while 22 samples were sampled at the Strem Biogas plant during the same period. Two to three samples were taken per week from four full-scale reactors for a total of 64 samples during the four week period. The feedstock compositions consisted of mixtures of pig manure and various energy crops and crop residues in the Reidling plant and inoculum cow manure and maize silage at the Strem plant.

### Sub-sampling, sample preparation

For wet chemistry, including VFA analysis, and for NIR spectroscopy, several 1 L laboratory bottles were incrementally sub-sampled from the primary (10 L) digesting biomass samples.<sup>10</sup> Two parallel samples were chosen randomly for analysis and further treatment in this study. The optimal TOS-correct way to sub-sample highly heterogeneous primary bio-slurry is by mechanical agitation to keep the bio-slurry in a state of maximum homogenisation while being sub-sampled. The first series of samples was frozen for VFA analysis at the laboratories of the IFA, Tulln. The second series was frozen and then transported to the ACABS<sup>b</sup> laboratories, Aalborg University, Esbjerg, for further measurement of the remaining wet chemical analysis (Esbjerg, Denmark) and for the NIR measurements (Kiel, Germany).

<sup>b</sup>*Applied Chemometrics, Analytical Chemistry, Applied Biotechnology, Bioenergy & Sampling research group*

### Reference analysis

The wet chemical parameters, TS, VS,  $\text{NH}_4^+$  and total-N, from the same samples as tested by the TENIRS equipment, were analysed at the ACABS laboratories, where all samples were analysed in triplicate and averaged. VFA were measured at the IFA, Tulln, using high-performance liquid chromatography (HPLC). The VFAs were measured in duplicate and averaged.

### Total solids (TS) and volatile solids (VS)

TS are the fraction of the total wet weight of a sample from which the water has been evaporated in an oven at 105°C for a period of 24 h. Total volatile solids were determined as the difference between total solids and the weight of the ashes from the sample kept in the oven for two hours at 550°C.

### Total nitrogen (total-N) and ammonium nitrogen ( $\text{NH}_4^+$ )

Total-N and  $\text{NH}_4^+$  in the samples were analysed by utilising a FIASStar 500 analyser with 5027 sampler (Foss, Hilleroed, Denmark). The analyses were analysed according to the application note for the apparatus; AN 5202 for total-N and AN 5208 for  $\text{NH}_4^+$ .

### Total and individual volatile fatty acids (VFAs)

VFAs were analysed using an HPLC system, Agilent 1100 Series, RI-Detector (Agilent, Santa Clara, USA), column: Polyspher OA KC (Merck, Darmstadt, Germany). Sample preparation included two centrifugation steps with protein precipitation and a final filtration step. Every sample was prepared and measured twice. If the difference between the results was higher than 5%, new samples were prepared. Once a week, a standard solution was measured to recalibrate the equipment.

### NIR equipment and methods

A robust NIR spectrometer, Zeiss Corona 45 NIR; (Zeiss, Oberkochen, Germany), with a scan range from 960–1600 nm, was used for all measurements. The TENIRS instrumentation was configured as an at-line flow-through NIR measuring cell with an integrated horizontal circulation loop, allowing a sample size of 1 L to be measured in full (Figure 3). This tool has been thoroughly tested and proven during pig feeding and manure trials.<sup>8</sup>

In the present case, TENIRS was used for at-line measurement of the series of samples taken in Austria. In this study, the TENIRS equipment was configured as a simulated at-line NIR measuring cell, based on 1 L volume samples, because it was not physically possible to conduct the study directly at-line on the fermentation locations. Further studies are now being conducted where TENIRS measuring is used directly on-line in the laboratory, 5 L volume fermenters, as well as in full-scale bio-conversion processes, 150 L and 1800 × 10<sup>3</sup> L volumes, integrating

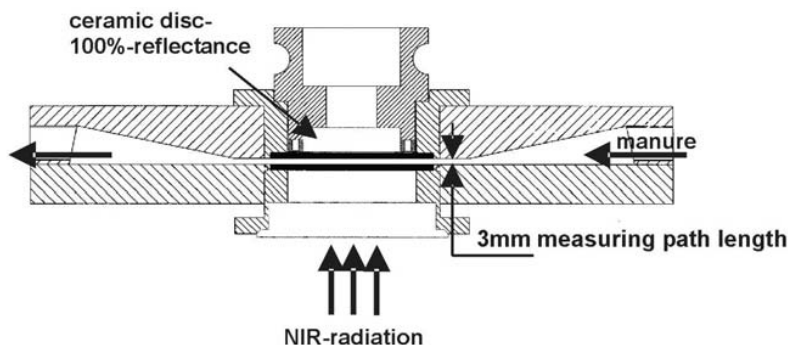

Figure 3. Schematic TENIRS flow-through measuring cell, from Andree *et al.* (2005).<sup>8</sup>

the flow-through cell equipment in various recurrent loop configurations.<sup>10</sup>

Bio-slurry can be analysed by TENIR only after a homogenising run through a macerating unit, comminuting solid particles and fibres. The TENIRS flow-through cell has a measuring cell dimension spacing demanding solid particles to be below 3 mm in this study (Figure 3). One sample, sample no. 2 from Reidling, was accidentally lost due to clogging in the flow-through cell at the beginning of the project. All other samples were successfully macerated.

Based on the measuring cell described above, a stand-alone prototype for an operating TENIRS system has been constructed and tested in the present project (Figure 4). By physically transporting the secondary 1 L samples to this instrument, it was possible to simulate an at-line monitoring PAC application without loss of generality.

### Statistical methods–data analysis

Principal component analysis (PCA) describes the internal data structure of a multivariate data set. It describes a multivariate data set with fewer descriptors than in the original data set by decomposing it into a new compound co-ordinate system, simultaneously separating data structure from noise. This new co-ordinate system of principal

components corresponds to linear combinations of all the original variable axes, spanning the data in the directions of highest variance; general PCA descriptions can be found in References 16 and 17.

In multivariate calibration, a large number of NIR variables ( $X$ ) are used to develop a calibration against a given reference variable ( $Y$ ), for example, a chemical reference variable. Using the commercial software Unscrambler (Camo, Oslo, Norway), partial least squares (PLS) regression was used to model and predict  $Y$  data directly from TENIRS  $X$  data. PLS regression (PLSR) consists of three stages: model training—calibration, validation and prediction. Full chemometrics descriptions of these approaches can be found in previous publications.<sup>16,18</sup> Our objective was to develop calibrations and validate the models established by multivariate calibration, PLSR. In this study, TENIRS spectra served as  $X$  data, with process parameters as  $Y$  data.

It was a major task to identify full-scale digestion systems which could provide samples spanning the full range of relevant chemical values in order to provide optimal training data sets. The training set samples originated from two newly-established biogas facilities in Austria, fitted out for simultaneous recording of chemical and energy performance data. These facilities are under full monitoring control by

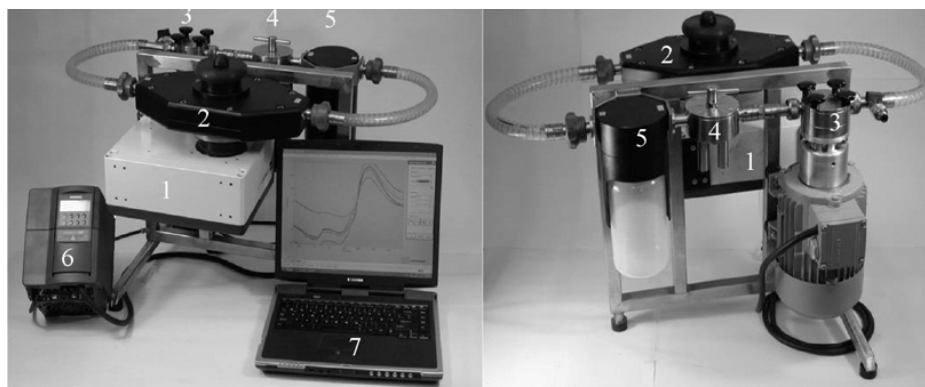

Figure 4. TENIRS stand-alone prototype, viewed from the front and back, from Andree *et al.* (2005).<sup>8</sup> The TENIRS system consists of: (1) Zeiss Corona 45 NIR spectrophotometer, (2) measuring cell, (3) pump, (4) multi-way valve, (5) sample holder with 1 L container, (6) frequency converter and (7) Control PC.



IFA through a national programme, reNet-Austria. Four energy crop biogas-fermenters in various stages of organic loading and at different stages of their start-up phases were involved in the present project. Thus, passive sampling in an arbitrary month of the year will not necessarily result in perfectly-spaced intervals for all monitoring variables of interest, but with some persistence we succeeded in establishing acceptable training data set ranges for all key process variables reported below.

All data models are based on  $\log(1/R)$  spectra. There are no marked peaks in raw TENIRS spectra—on the contrary, there are only very broad crests and valleys—nor are there any small-resolution noise elements in the spectra, which display only very gently-changing background trends as well (Figure 5). For these reasons, standard NIR pre-treatments were not found to give rise to improved models over the raw  $\log(1/R)$ -based models presented below: nor were improvements found to result from first and/or second derivative spectra, or from any smoothing or cropping of noisy terminal ends of the full wavelength ranges employed; there was simply no noise present at either end. Because of this very simple continuous nature of the TENIRS spectra there was no need for more specific pre-treatments, for example, MSC.

All models reported below were validated using two-segment cross-validation, in the form of 50% random selection from the training set. Two-segment cross-validation is the closest form of test set validation possible in the small-sample scenario.<sup>16,17</sup>

## Results and discussion

### PCA model

PCA was used to characterise and explore the basic data set, while the ultimate prediction model developments of the full set of  $(X,Y)$  variables used PLS-1 regression analysis. The total of 64 samples were sub-divided into 42 samples originating from the location of Reidling and 22 samples from Strem. Only one gross outlier was found and deleted. For some PLS-1 models, for sensitive  $Y$ -variables, a further sub-population of outliers were deleted from the training set.

Figure 6 shows a PCA score plot of TENIRS spectra with the singular gross outlier already removed. There was a clear separation between the two geographically-separated plants with further internal sub-divisions also apparent. Samples from the Reidling fermenter one (R1) were in a clear cluster with samples close to or even overlapping with samples from the Reidling fermenter two (R2). Samples from the Strem fermenter one (S1) and Strem fermenter two (S2) lay far from those of the Reidling fermenters in the score plot. This illustrates clearly that the four bioreactors were at different stages of fermentation, in start-up as well as in the later stages of more or less stable process conditions. R1 had been running for one year as the main fermenter at the time of sampling while in R2, direct substrate dosage had just started. S1 and S2 were both in the start-up phase; the production of biogas started a few months earlier. Fermenters one and two at both locations,

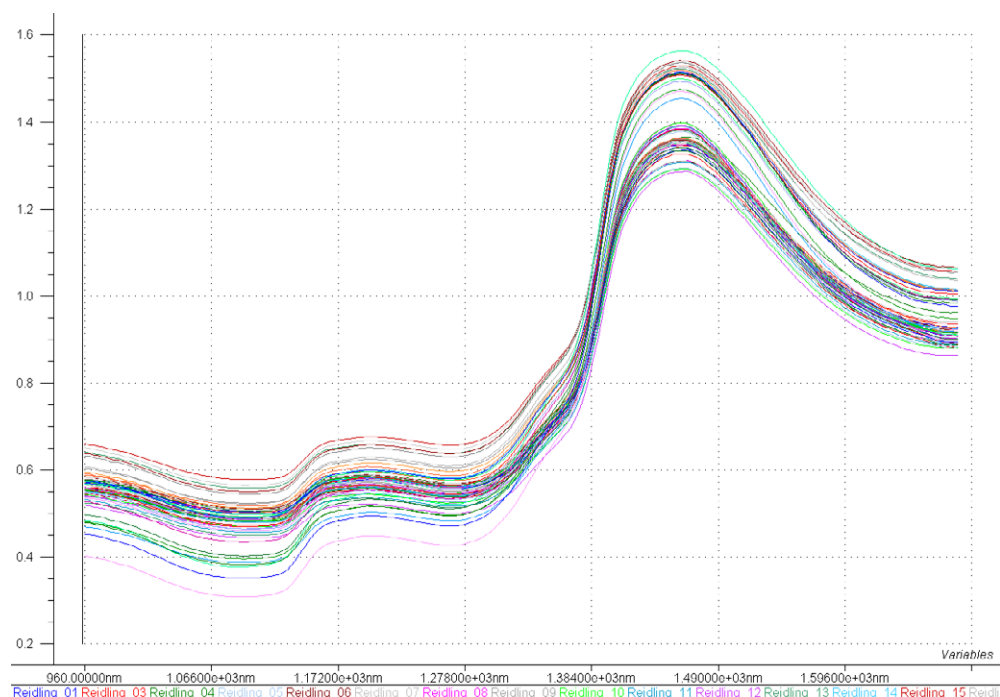

Figure 5. Raw NIR spectra of all original 63 samples; spectra were used as  $\log(1/R)$ . Because of the low resolution nature of the TENIRS spectra, expressed as very broad, continuous peaks and valleys, there was no need for more specific pre-treatments, for example, derivatives or MSC, see text. Note one gross and several minor outliers.

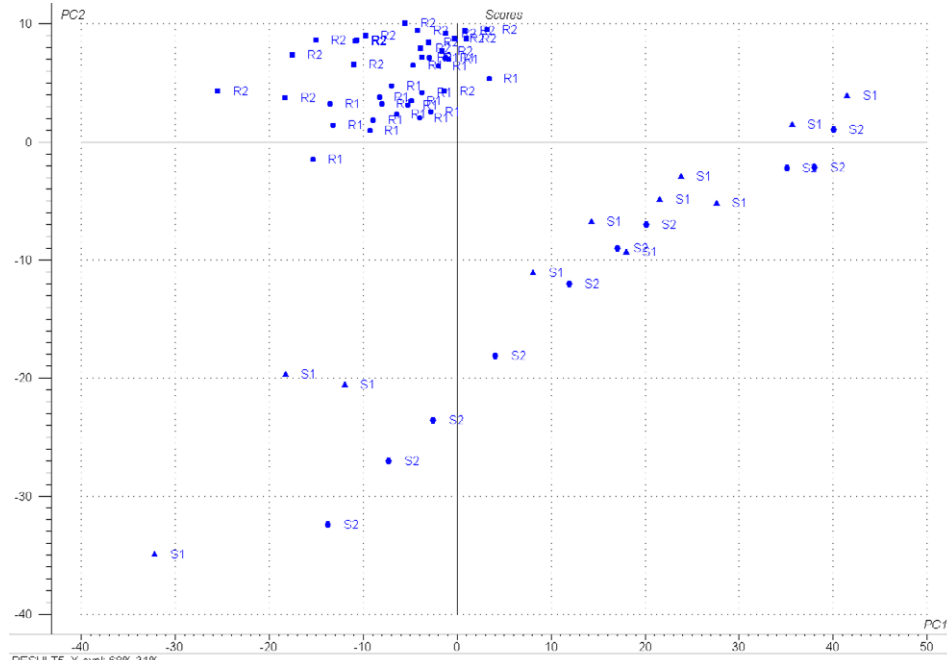

Figure 6. PCA score plot of fermenter data sets from both the Reidling (R) and Strem (S) locations based on TENIRS spectra. One outlier described in the text has been excluded (Strem58). [S1, S2] and [R1, R2] signifies the number 1 and 2 reactors of either locations, respectively, (see text).

were connected for serial digestion, shown clearly by their relative (S1)  $\rightarrow$  (S2) and (R1)  $\rightarrow$  (R2) score positions in the PCA score plot, PC1 vs PC2.

### PLS1 models

#### TS/VS inter-relations

It was decided to present the volatile solid calibration/validation only, since the correlation coefficient between TS and VS was 0.999. VS is the more informative of these two analytes for process monitoring, because this parameter expresses the AD potential of the organic content, specifically the carbon content, in the heterogeneous bio-slurry. The difference between VS and TS values concerns inorganic compounds, mainly salts and minerals, expressed in the ash contents.

For the PLS-1 prediction model for VS, the linear regression relationship shows a very strong correlation between the  $X$  variables (NIR) and the  $Y$  variables (Figure 7). The  $Y$ -modelled variance was higher than 95% for two PLS components. One outlier was removed (see above). Two-segment cross-validation showed excellent prediction assessment statistics,  $r^2=0.97$  (precision),  $RMSEP$  2.64 (precision) with slope=0.98 and bias  $-0.044$  (accuracy).

#### Ammonium ( $NH_4^+$ )

$NH_4^+$  is one of the most important chemical parameters during anaerobic digestion processes. If it is present at fairly high concentrations, it tends to have inhibitory effects. Ammonium concentration depends on the protein content of the feedstock, or originates from other nitrogen sources

in the feedstock. The feedstock in Europe is dominated by liquid manure and food waste, often with fairly high amounts of nitrogen; however, C/N-balanced feedstock like maize silage is consistently increasing in importance. In the present experiment, we clearly managed to obtain samples with two main levels (Figure 8).

The PLS-1 model for ammonium, therefore, shows a very high correlation between the NIR spectra ( $X$ ) and the  $NH_4^+$ , reference variable ( $Y$ ). The  $Y$ -modelled variance is higher than 95% for two PLS components. One outlier was removed, see above. Two-segment cross-validation also shows excellent statistics  $r^2=0.99$  (precision) and slope=0.98 (accuracy) here. **There is no reason to expect other than a linear filling-in** if data from other process stages were available.<sup>1,2,8</sup> However, this model would need to be tested further when intermediate samples are available

#### Volatile fatty acids (VFAs)

VFAs can accumulate during the anaerobic digestion process, as increasing accumulation directly reflects process behaviour and/or imbalances. The VFA concentration has been the intermediary compound suggested most often for monitoring anaerobic digestion processes.<sup>5,19–21</sup> Several studies have pointed out that, in addition to monitoring the total VFA behaviour, individual volatile fatty acids will deepen the process understanding. The ratio between acetic acid and propanoic acid in the process can provide valuable information as an early warning before a process failure would eventually occur.<sup>20,21</sup> Consequently, it will be of interest to try to model as many of the volatile fatty acids as possible.

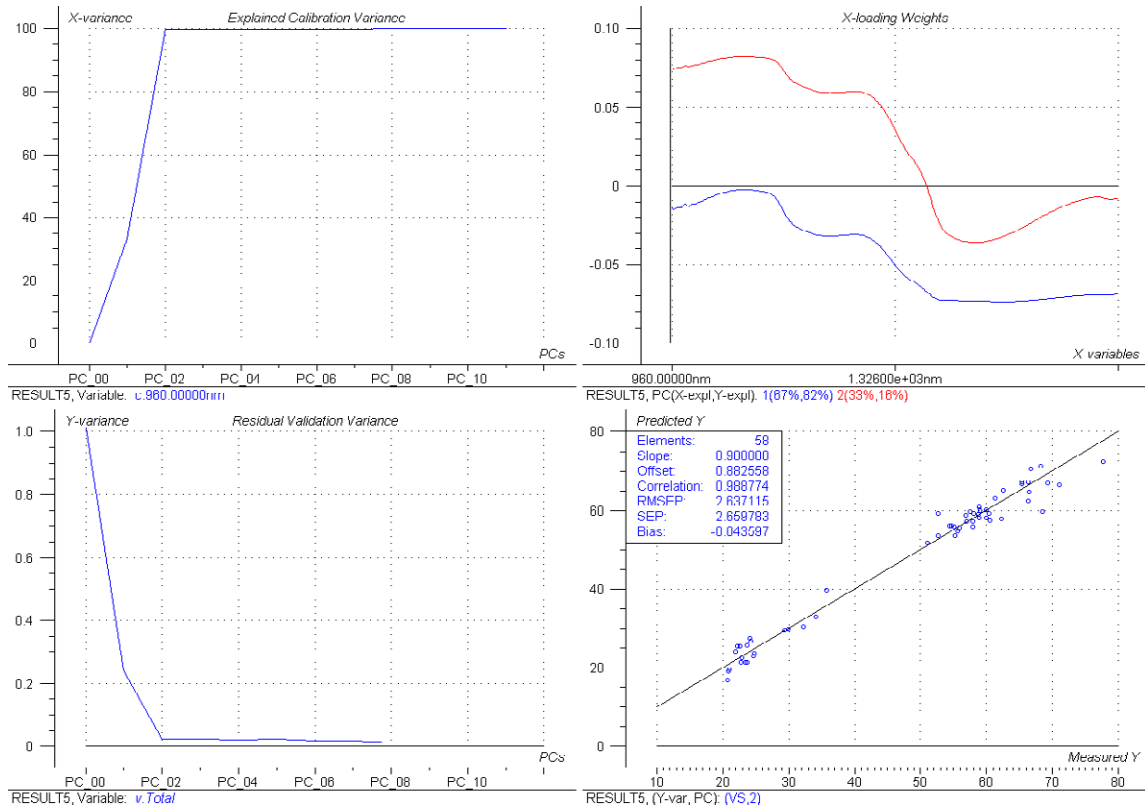

Figure 7. PLS-1 prediction model.  $Y$  = volatile solids content (VS), two-segment cross-validation, two PLS-components, TENIRS data, one outlier removed (Strem 58).

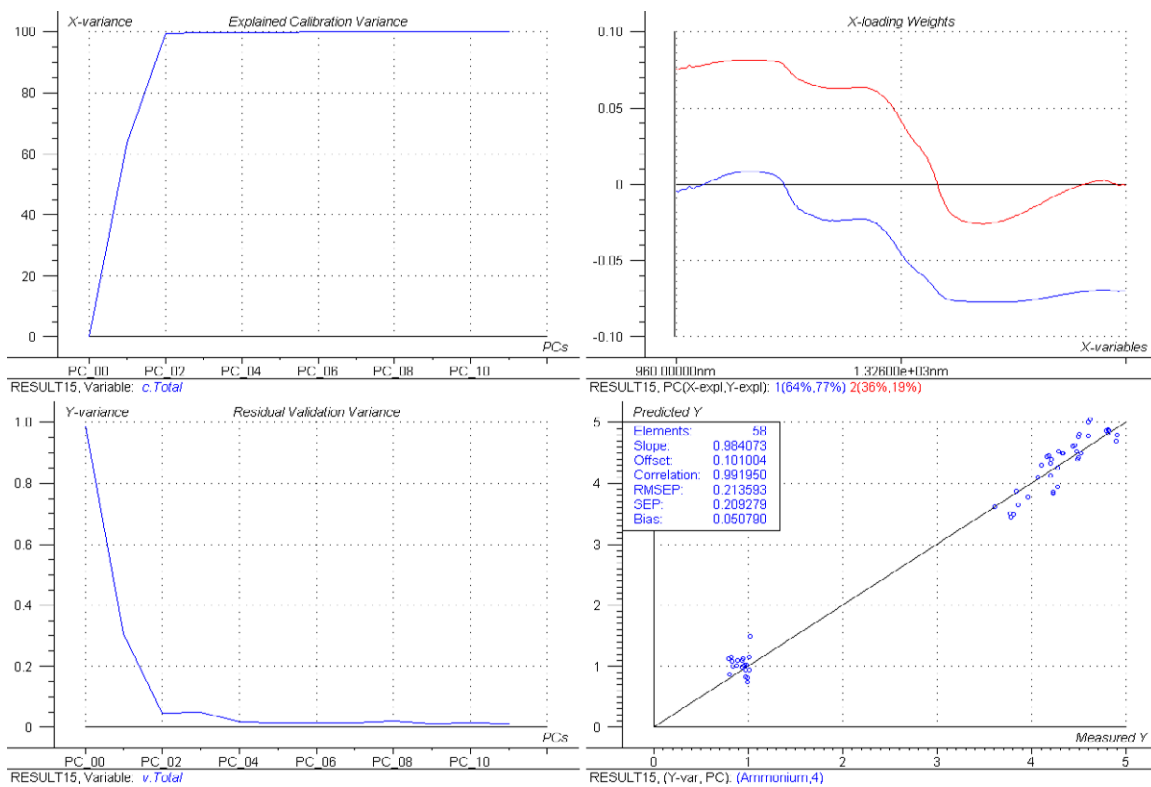

Figure 8. PLS-1 prediction model.  $Y$  = ammonium, two-segment cross-validation, four PLS components, one outlier removed (Strem 58).



Table 1. PLS modelling results for all analytes. The table includes average, standard deviation, minimum and maximum values and correlation coefficient (*CV*) for the data sets.

	No. of PCs	No. of outliers	Slope (accuracy)	$r^2$ (precision)	Average	<i>SD</i>	Min.	Max.	<i>CV</i> [%]
TS [g kg <sup>-1</sup> ]	1	2	0.98	0.98	63.2	22.7	22.0	98.5	35.9
VS [g kg <sup>-1</sup> ]	1	2	0.98	0.98	47.8	18.0	15.1	77.6	37.6
Total-N [g L <sup>-1</sup> ]	5	6	0.98	0.97	6.3	3.1	1.5	10.1	50.0
Ammonium [g kg <sup>-1</sup> ]	1	4	0.98	0.98	3.1	1.7	0.8	4.9	52.8
Acetic acid [mg L <sup>-1</sup> ]	6	14	0.94	0.85	939.6	724.2	37.0	2906.0	77.1
Propanoic acid [mg L <sup>-1</sup> ]	6	20	0.78	0.76	142.6	125.8	0.0	553.5	88.2
Iso-butanoic acid [mg L <sup>-1</sup> ]	5	18	0.63	0.38	36.8	30.9	0.0	110.5	84.0
Butanoic acid [mg L <sup>-1</sup> ]	7	11	0.87	0.73	38.2	25.7	0.0	90.5	67.1
Iso-valeric acid [mg L <sup>-1</sup> ]	6	11	0.60	0.54	28.7	25.2	0.0	98.0	87.8
Valeric acid [mg L <sup>-1</sup> ]	7	14	0.71	0.41	21.5	21.2	0.0	71.0	98.5
Total VFA [mg L <sup>-1</sup> ]	6	14	0.94	0.84	1191.3	865.1	52.0	3781.0	72.6

Table 2. Correlation matrix between all of the chemical constituents before NIR prediction (*r* values).

	TS	VS	Total-N	Ammonium	Acetic acid	Propanoic acid	Iso-butanoic acid	Butanoic acid	Iso-valeric acid	Valeric acid	Total VFA
TS	1.00										
VS	1.00	1.00									
Total-N	0.95	0.94	1.00								
Ammonium	0.97	0.97	0.97	1.00							
Acetic acid	0.69	0.68	0.82	0.72	1.00						
Propanoic acid	0.27	0.25	0.44	0.28	0.82	1.00					
Iso-butanoic acid	-0.09	-0.10	0.06	0.01	0.31	0.42	1.00				
Butanoic acid	-0.24	-0.25	-0.22	-0.22	-0.05	0.00	0.92	1.00			
Iso-valeric acid	0.06	0.05	0.20	0.14	0.43	0.42	0.67	0.63	1.00		
Valeric acid	-0.10	-0.11	0.00	-0.01	0.19	0.28	0.93	0.84	0.57	1.00	
Total VFA	0.61	0.59	0.75	0.64	0.99	0.87	0.43	0.05	0.52	0.30	1.00

The prediction statistics for total VFA, the sum of six individual VFA's, presented in Table 1, demonstrate a significant residual variability defined by the individual measurements, as evidenced by poor validation statistics slope (accuracy) and  $r^2$  (precision).

Table 2 presents correlation coefficients between all the chemical constituents. The highest correlation occurs between TS and VS. Additionally, high correlation was noticed between TS, VS and total-N and ammonium. A correlation between acetic and propanoic acids, equal to 0.82, should be notified, as the acetic propanoic ratio can be used for anaerobic digestion process control.

The two models illustrated in Figures 9 and 10 are the two most often used VFA process indices and they perform by far the best of all VFA variables here. It is a general experience that all other individual VFA's than acetic acid are very difficult to model with routine monitoring measures, that is routine process sampling and analysis. The reasons for low  $r^2$ —equivalently, high *RMSEP*<sup>16,17</sup>—can be manifold. Within chemometrics, consensus traditionally focuses on poor laboratory analysis quality (*Y* data), low absolute concentrations close to the effective detection limits and/or lack of other information in the *X* spectra. The

traditional explanation of lack of a sufficient number of calibration samples can not be invoked here, since the high residual variance is already manifested in the existing data sets—more samples will only express the same feature. Under the given conditions, the small sample case, one cannot hope for a better modelling or prediction performance simply because of more samples, since all samples are realisations from the same population. It is traditionally assumed that by employing extensive replication and averaging, these results can be improved, but this is only a half-way measure, however, as the individual samples all carry the full load of sampling errors, which are not normally distributed.<sup>11,15</sup>

Recently, a significantly deeper understanding of these features has come about, for example, regarding the relationship between the concentration level of the analyte(s), the local and global material heterogeneity and the resulting fundamental sampling error (FSE) as well as the grouping and segregation error (GSE), underlying that considerable care is necessary in order to be able to sample heterogeneous systems representatively. It is also necessary to be in full command of the sampling process which, itself, also produces significant sampling errors.

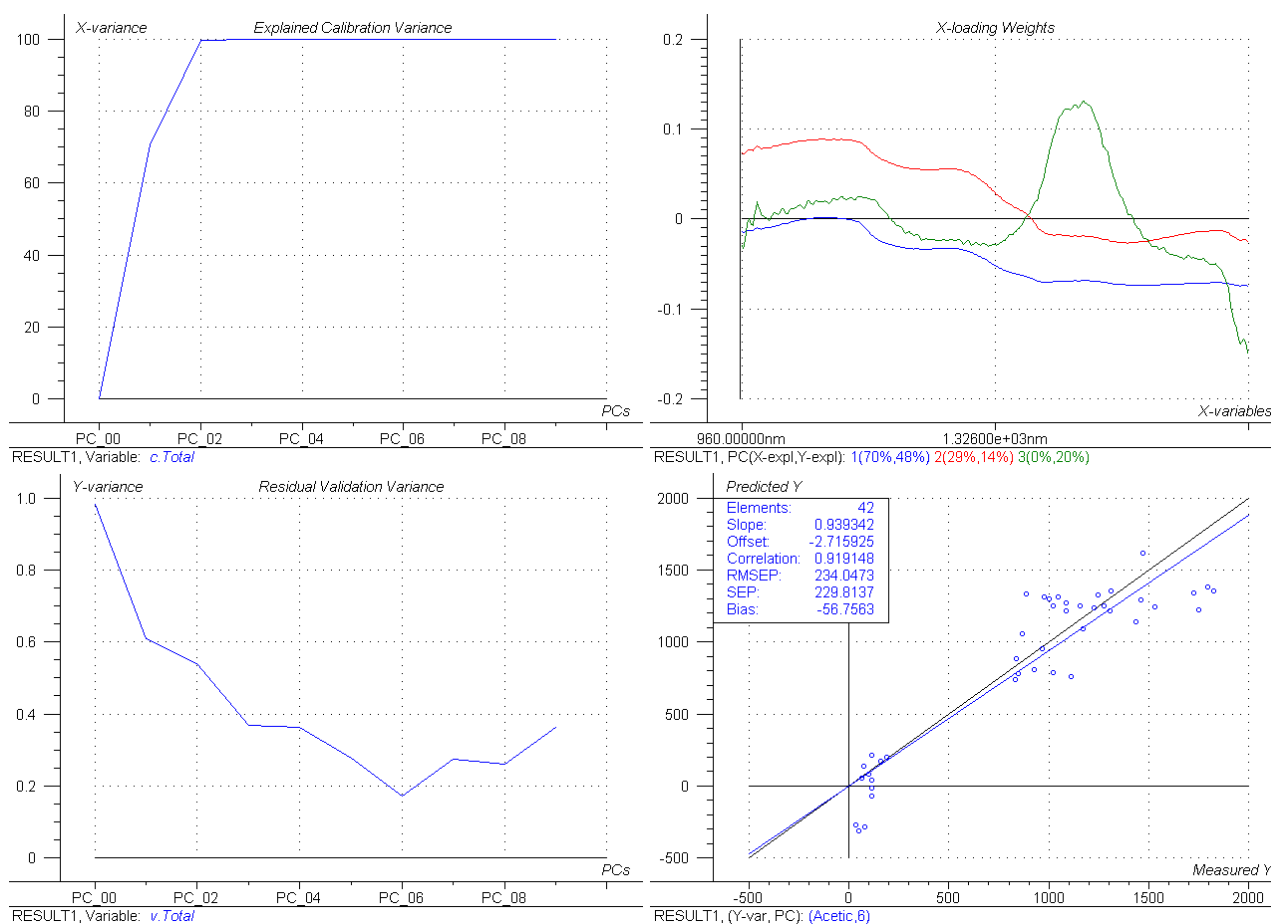

Figure 9. PLS1 prediction model. *Y*=acetic acid; two-segment cross-validation. six PLS components, 14 minor outliers removed (see text).

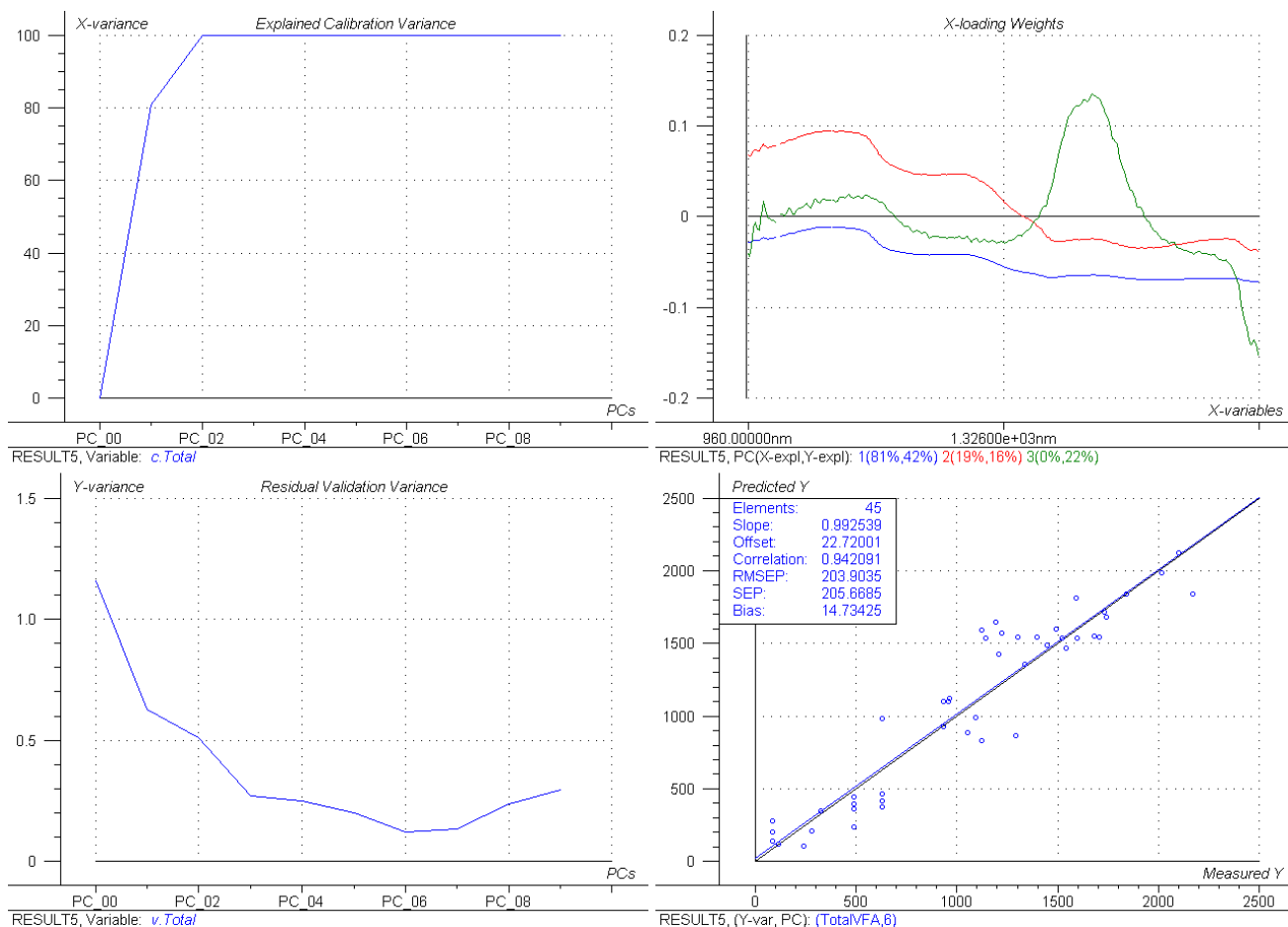

Figure 10. PLS-1 prediction model. Y=total-VFA; two-segment cross-validation, TENIRS data, six PLS components, 14 minor outliers removed (see text).

These aspects go under the name of the TOS which has been extensively documented and illustrated in a series of founding publications.<sup>11,15</sup> There is no doubt that very careful TOS representative sampling is necessary in order to be able to model the more sensitive individual VFA. The present pilot study was **only aimed at indicating this potential** as comprehensibly as possible within the constraints of the experimental reNet setting.

The overall PLS-1 prediction model for acetic acid, covering both biogas plants, showed a relatively good correlation, albeit weaker than for the VS and NH<sub>4</sub><sup>+</sup> models in the prediction assessment plot (Figure 9). Fourteen individual outliers had to be deleted for this model, 14 out of a total of 63 samples, for the reasons delineated above. The two-segment cross-validation of the resulting training set led to estimates for prediction precision of  $r^2=0.85$  and slope=0.94 (accuracy). This regression needed six PLS components to model acid values from the TENIR X variables. The loading weights of the first three PLS components are shown in the upper right panel. The model is dominated the by full-spectrum translation relationships,  $X \rightarrow Y$ , as evidenced by the first two PLS-components, with the third

PLS component signifying one major specific peak area in the central part of the spectrum (Figure 9).

The PLS-1 prediction model the for cumulative total VFA content, measured by TENIRS (X) and by HPLC laboratory equipment at the IFA-Tulln for the corresponding Y VFA variables, shows a similar correlation compared to the acetic acid of the fermented bio-slurry. This model also needs six PLS components and the same set of 14 outliers had to be deleted. The two-segment cross-validation led to estimates for precision of  $r^2=0.84$  and slope=0.94 (accuracy). The individual loading weights show very similar behaviour to that for acetic acid—no surprise, since acetic acid is the dominant component in the total VFA complement. The individual 14 outliers are very persistent throughout all individual VFA models, as reported in Table 1, which also reports on models for all other analysed chemical constituents.

### Discussion

Bio-slurries are complex and heterogeneous materials originating from several sources in the farming and food processing sectors, digested or co-digested in bioreactors.

in the anaerobic conversion processes. Even with a good management protocol and chemical analysis of the heterogeneous feedstock, it will not be possible to control the process completely. In energy crop biogas plants, the control of the feedstock can be quite good, if only a few feedstock types are utilised. It is clear from the present results that the systems are not overly complex but, even so, the models for individual volatile acids were significantly sensitive to small-scale deviations, necessitating a significant proportion of outliers to be removed, 14 out of 63 samples, corresponding to 22%. It is not believed that this will reduce the general value and usefulness of the models, as their origin, due to the forced sub-optimal primary sampling, is a well-understood issue.<sup>11,15</sup> The remaining data structures are very strong and pervasive, reflecting stable physico-chemical  $X \rightarrow Y$  relationships.

It would be highly recommendable and advantageous if on-line chemical analytical results could document the quality and the energy strength of the biomass feedstock as well as the fermentation process itself. There is always a demand for new and robust analysis and management tools to help operate anaerobic digestion systems. Until now, process control included only measuring and controlling process temperature and pH-monitoring based on samples extracted from the bioreactors. From the head space of the bioreactor, important data of biogas yield and quality is monitored. By the gate, or via pumping and pipeline inlets to the AD system, the feedstock quality will occasionally be checked for its quality parameters, but this is a rare scenario.

An on-line measurement system has been seriously lacking for many years. The best attempts have been through projects searching for on-line VFA-GC, gas chromatography measurements in a liquid or gaseous phase,<sup>21</sup> but this is a quite a complicated at-line measurement configuration and management of the equipment is demanding of both manpower and technology. This situation was part of the background for TENIRS trials in search of a robust and easily-managed tool for on-line measurement in pipeline flows of bio-slurries from fermentation processes and in the anaerobic digestion process.<sup>10,18,23</sup>

As documented by the present results, it is now possible to develop satisfying calibration and validation models for many of the targeted constituents in this study. The relatively high number of six PLS components in the models of acetate and total-VFA demonstrate the complexity of these types of constituent in bio-slurries. *RMSEP* for these models can be reduced by invoking TOS-correct sampling at the primary sampling point.<sup>11,15</sup> The NIR spectrophotometer used in this study (Zeiss Corona 45 NIR, scan range from 960–1600 nm) is possibly not able, to a sufficient degree, to obtain all the individual volatile fatty acid information needed in the present configuration but is, nevertheless, adequate enough to furnish answers for this at-line feasibility study.

In demonstrating the value and functionality of PAC tools, one always has to be aware of establishing a maximal

spanning of the calibration data set for chemometric calibration and validation. This study documented that acceptable NIR calibration and validation for total solids, volatile solids, total nitrogen, ammonium, acetic acid and volatile fatty acids can be developed and used for prediction of the behaviour and condition of the anaerobic digestion process in full-scale bioreactors. The calibration results obtained for VS were the same for TS because of their strong correlation.

It was not possible to collect fully independent test sets due to the piggy-back nature of the primary full-scale project. All PLS1-models were, therefore, validated using two-segment cross-validation, which is as close as possible to test set validations based on half the training sets available.<sup>16</sup> The intention of this study was to delineate the feasibility of PLS prediction for the important intermediate fermentation parameters based on the TENIRS system, not to produce final, fully validated industrial prediction models.

Similar studies of raw manure or other types of bio-slurries are as promising as the present results for introducing NIR measurements and, specifically, for the setting up of TENIRS equipment types for industrial operation in the near future.<sup>2,8</sup> Earlier studies made by static NIR measurement illustrate that the present type of flow-through NIR measurement of bio-slurries are more precise and accurate and reflect the full-scale operational process directly.<sup>8</sup> Bio-slurries in AD and other fermentation processes are almost always pumped in pipe-lines, fed semi-continuously or continuously into the bioreactor systems and, further on, to the post treatment technologies. On-line PAC measurements in pipe-line systems at fermentation plants have huge importance and potential. This is especially important for heterogeneous samples with a tendency to segregate. For bio-slurries with a significant total solid content, this could easily lead to measurements with high sampling errors, if measured at-line in a static manner. A very important factor regarding the accuracy of measurement concerns the analytical sample volume. The flow-through cell used in this study was working on the entire sample volumes of 1 L, transgressing many competing analytical approaches that deal with significantly smaller volumes, often in the order of less than 100 mL. The working condition with this equipment is that the total volume is pumped in a recurrent loop and flows through the measurement cell several times. This allows a high degree of representativity of the measured analytes, *cfr.* TOS.<sup>15</sup>

The TENIRS flow-through cell will be used in future stages of research and development as an external, recurrent loop directly coupled to bio-fermenters at all scales from 5 L, via 150 L to full-scale bioreactor systems at ACABS and collaborating biogas plants reaching 1800 m<sup>3</sup> volume. In this way, TENIRS will operate fully as an on-line process analytical technology system for bioreactor process monitoring. This will bring forward reliable, continuous information of the bioprocess, its raw materials, intermediates and final products.<sup>10</sup>

## Conclusions

This method-development project was based on samples from four full-scale Austrian bio-fermenters, in which the contents were analysed for key AD process monitoring analytes by one of the strongest PAC tools available—NIR spectroscopy. These measurements were made off-line, at-line, but in a context realistically simulating full-scale at-line/on-line applications. Specifically, PAC monitoring for TS, VS, total-N,  $\text{NH}_4^+$ , total-VFA and acetic acid in biogas production using TENIRS was successfully demonstrated.

The TENIRS approach and multivariate data analyses of important intermediates in the anaerobic fermentation process resulted in acceptable feasibility models able to predict these key AD process parameters. TENIRS is a viable new alternative for real-time, at-line or on-line characterisation of biogas fermentation operations, both of raw materials, as evidenced by other basic TENIRS documentation studies<sup>8,18</sup> and the vital process intermediates shown here. PAC technologies for early warning in monitoring, controlling and adjusting bio-conversion processes are very promising, not only in the present AD context but also in other types of more complex scenarios, for example, in future biorefinery production and management systems.

The presently-used systems are not top-of-the-line research instruments, but reasonably priced, robust systems readily available globally and many local producers exist. Once the feasibility of this type of bioprocess monitoring PAC facility has been further developed, there are many less expensive NIR spectroscopy systems available on the market. This opens up possibilities for problem-dependent, low-cost systems to be designed and implemented.

## References

1. M. Hansson, A. Nordberg, I. Sundh and B. Mathisen, "Solid Waste—early warning of disturbances in a laboratory scale MSW biogas process", *Water Sci. Technol.* **45**, 255–260 (2002).
2. A. Nordberg, M. Hansson, I. Sundh, E. Nordkvist, H. Carlsson and B. Mathisen, "Anaerobic digestion of solid waste—Monitoring of a biogas process using electronic gas sensors and near-infrared spectroscopy (NIR)", *Water Sci. Technol.* **41**, 1–8 (2000).
3. Y. Zhang, Z. Zhang, N. Sugiura and T. Maekawa, "Monitoring of methanogen density using near-infrared spectroscopy", *Biomass Bioenerg.* **22**, 489–495 (2002). doi: [10.1016/S0961-9534\(02\)00019-3](https://doi.org/10.1016/S0961-9534(02)00019-3)
4. H.B. Møller, S.G. Sommer and B.K. Ahring, "Methane productivity of manure, straw and solid fractions of manure", *Biomass Bioenerg.* **26**, 485–495 (2004). doi: [10.1016/j.biombioe.2003.08.008](https://doi.org/10.1016/j.biombioe.2003.08.008)
5. B.K. Ahring and I. Angelidaki, "Monitoring and controlling the biogas process", *Proceedings of the 8<sup>th</sup> International Conference on Anaerobic Digestion*. 25–29 May, Sendai, Japan, pp. 32–39 (1997).
6. I. Angelidaki, L. Ellegaard and B.K. Ahring, "Applications of the anaerobic digestion process", in *Biomethanisation II*, Ed by B.K. Ahring. Springer Verlag, Berlin, Germany, p. 1–33 (2003).
7. I. Angelidaki, L. Ellegaard, A.H. Sørensen and J.E. Schmidt, in *Anaerobic processes*. DTU, Copenhagen, Denmark (2002).
8. H. Andree, M. Dolud and T. Hügle, "TENIRS—NIR analysis of heterogeneous bioslurries", *Aalborg University Esbjerg, Baltic Biorefinery Symposium*, 26–28 May, Ed by ACABS, pp. 141–148, (2005).
9. G.D. Batten, P.C. Flinn, L.A. Welsh and A.B. Blakeney, *Leaping ahead with near infrared spectroscopy*. Near Infrared Spectroscopy Group, RACI, North Melbourne, Australia (1995).
10. J.B. Holm-Nielsen, C.K. Dahl and K.H. Esbensen, "Representative sampling for process analytical characterisation of heterogeneous bioslurry systems—a reference study of sampling issues in PAT", *Chemometr. Intell. Lab. Syst.* **83**, 114–126 (2006). doi: [10.1016/j.chemolab.2006.02.002](https://doi.org/10.1016/j.chemolab.2006.02.002)
11. P.P. Mortensen and R. Bro, "Real-time monitoring and chemical profiling of a cultivation process", *Chemometr. Intell. Lab. Syst.*, in press (2006). doi: [10.1016/j.chemolab.2006.04.022](https://doi.org/10.1016/j.chemolab.2006.04.022)
12. L. Petersen, *Pierre Gy's Theory of Sampling (TOS) in Practice: Laboratory and Industrial Didactics*. Aalborg University Esbjerg, Esbjerg, Denmark (2005).
13. P. Gy, *Sampling for Analytical Purposes*. John Wiley and Sons Ltd, Chichester, UK (1998).
14. F.F. Pitard, *Pierre Gy's sampling theory and sampling practice*, 2<sup>nd</sup> Edn. CRC Press Ltd, London, UK (1993).
15. L. Petersen, P. Minkkinen and K.H. Esbensen, "Representative sampling for reliable data analysis: Theory of Sampling", *Chemometr. Intell. Lab. Syst.* **77(1/2)**, 261–277 (2005).
16. K.H. Esbensen, *Multivariate Data Analysis—in practice. An introduction to Multivariate Data Analysis and Experimental Design*. Aalborg University Esbjerg, Camo Inc., Esbjerg, Denmark (2001).
17. H. Martens and T. Næs, *Multivariate Calibration*, Updated version. John Wiley and Sons, Chichester, UK (1991).
18. P. Jørgensen, J.G. Pedersen, E.P. Jensen and K.H. Esbensen, "On-line batch fermentation process monitoring—introducing 'biological process time'", *J. Chemometr.* **18**, 81–91 (2004). doi: [10.1002/cem.850](https://doi.org/10.1002/cem.850)
19. B.K. Ahring, M. Sandberg and I. Angelidaki, "Volatile fatty acids as indicators of process imbalance in anaerobic digestors", *Appl. Microbiol. Biotech.* **43(3)**, 559–565 (1995). doi: [10.1007/s002530050451](https://doi.org/10.1007/s002530050451)
20. D.T. Hill and R.D. Holmberg, "Long chain fatty acid relationships in anaerobic digestion of swine waste",

- Biol. Wastes* **23**(3), 195–214 (1988). doi: [10.1016/0269-7483\(88\)90034-1](https://doi.org/10.1016/0269-7483(88)90034-1)
21. K. Boe, *Online monitoring and control of the biogas-process*. Institute of Environment and Resources, Technical University of Denmark, Lyngby, Denmark (2006).
  22. M. Halstensen, *Acoustic Chemometrics– Experimental multivariate sensor technology and development of system prototypes for industrial multi-phase characterisation: selected forays*. Norwegian University of Science and Technology, Trondheim, Norway (2001).
  23. J.P. Steyer, O. Bernard, D.J. Batstone and I. Angelidaki, “Lessons learnt from 15 years of ICA in anaerobic digesters”, *Water Sci. Technol.* **53**, 25–33 (2006).

*Received: 22 September 2006*

*Revised: 29 December 2006*

*Accepted: 5 January 2007*

*Web Publication: 13 March 2007*



# Paper III

Jens Bo Holm-Nielsen, Carina J. Lomborg, Piotr Oleskowicz-Popiel, Kim H. Esbensen

*On-line Near Infrared monitoring of glycerol-boosted anaerobic digestion processes – evaluation of Process Analytical Technologies*

Biotechnology and Bioengineering  
Volume 99, no. 2, pp. 302-313, 2008

DOI: 10.1002/bit.21571





# On-Line Near Infrared Monitoring of Glycerol-Boosted Anaerobic Digestion Processes: Evaluation of Process Analytical Technologies

Jens Bo Holm-Nielsen, Carina Juel Lomborg, Piotr Oleskowicz-Popiel, Kim H. Esbensen

Applied Chemometrics, Analytical Chemistry, Acoustic Chemometrics, Applied Biotechnology, Bioenergy and Sampling Research Group, Esbjerg Institute of Technology, Aalborg University, Niels Bohrs Vej 8, 6700 Esbjerg, Denmark; telephone: +45-7912-7715; fax: +45-6650-1091; e-mail: jhn@aaue.dk

Received 29 March 2007; revision received 7 June 2007; accepted 26 June 2007

Published online 11 July 2007 in Wiley InterScience (www.interscience.wiley.com). DOI 10.1002/bit.21571

**ABSTRACT:** A study of NIR as a tool for process monitoring of thermophilic anaerobic digestion boosted by glycerol has been carried out, aiming at developing simple and robust Process Analytical Technology modalities for on-line surveillance in full scale biogas plants. Three 5 L laboratory fermenters equipped with on-line NIR sensor and special sampling stations were used as a basis for chemometric multivariate calibration. NIR characterisation using Transflexive Embedded Near Infra-Red Sensor (TENIRS) equipment integrated into an external recurrent loop on the fermentation reactors, allows for representative sampling, of the highly heterogeneous fermentation bio slurries. Glycerol is an important by-product from the increasing European bio-diesel production. Glycerol addition can boost biogas yields, if not exceeding a limiting  $5\text{--}7\text{ g L}^{-1}$  concentration inside the fermenter—further increase can cause strong imbalance in the anaerobic digestion process. A secondary objective was to evaluate the effect of addition of glycerol, in a spiking experiment which introduced increasing organic overloading as monitored by volatile fatty acids (VFA) levels. High correlation between on-line NIR determinations of glycerol and VFA contents has been documented. Chemometric regression models (PLS) between glycerol and NIR spectra needed no outlier removals and only one PLS-component was required. Test set validation resulted in excellent measures of prediction performance, precision:  $r^2 = 0.96$  and accuracy = 1.04, slope of predicted versus reference fitting. Similar prediction statistics for acetic acid, iso-butanoic acid and total VFA proves that process NIR spectroscopy is able to quantify all pertinent levels of both volatile fatty acids and glycerol.

Biotechnol. Bioeng. 2008;99: 302–313.

© 2007 Wiley Periodicals, Inc.

**KEYWORDS:** anaerobic digestion (AD); near infrared spectroscopy (NIR); on-line measurement; volatile fatty acids (VFA); glycerol; process analytical technologies (PAT)

## Introduction

Bioethanol and biodiesel are the main biofuels utilized in the transportation sector world-wide, comprising of a total volume of 23.3 million tonnes in 2003, of which 6.4% was biodiesel (Mandil, 2004). The largest contributors of biofuels Brazil and the US produce mainly bioethanol. In Europe the production of biodiesel in the same year comprised 78% of the total amount of biofuels produced, resulting in 65% of the total world capacity. Further significant increase is planned for biofuels in Europe. A likely vision for year 2030 will be to exchange one fourth of the EU transportation fossil fuels by biofuels according to the Biofuels Research Advisory Council the predicted energy demand for transport is estimated to be 440 million tonnes of oil equivalents.

Biodiesel is produced by a direct trans-esterification of vegetable oils: rapeseed, palm, soybean, sunflower and other organic oil products or by-products. The main by-product from biodiesel production is glycerol with varying purity. When the conventional catalytic processes using caustic soda or sodium methylate process, known as the Fatty Acid Methyl Ester (FAME), is applied, purity falls between 80% and 95%. When applying a new heterogeneous process, consisting of mixtures of oxides of zinc and aluminium, a purity of 98% can be reached (Bournay et al., 2005). The glycerol helps to make the biodiesel production more economically feasible as it is a valuable by-product used by the cosmetic, medicine, and food industries. The industrial glycerol market is limited, so when the biodiesel production capacity is expanding glycerol ends up as a relatively low value energy by-product raising the cost of the biodiesel production (Mandil, 2004).

Correspondence to: J.B. Holm-Nielsen

 WILEY  
InterScience®  
DISCOVER SOMETHING GREAT

Therefore, there is a potential need for a new application, as an integrated biodiesel and biogas production in an integrated biorefinery concept. The primary by-product from anaerobic digestion, digested bioslurry, can be applied as primary macro and micro nutrients for growing energy crops needed for biodiesel production. At the same time the by-product from the biodiesel plant, glycerol can be applied as an extra C-source in co-fermentation with manure and other organic by-products in the anaerobic digestion process, thereby increasing the biogas yield. This paper is studying one part of the biorefinery loop, the application of glycerol for anaerobic co-fermentation with manure and other organic by-product feedstocks.

The co-fermentation effect is well known, especially in the Danish Biogas sector, which has been documenting the effect since the 1990s, showing doubling or tripling of the methane yield when quality guaranteed food waste and similar types of organic waste were combined with cow and pig slurries at biogas plants (Nielsen et al., 2002). From the biogas plant documentations it was found that high biogas production was positively correlated with addition of high concentrate organic by-products like vegetable oils, fish oil, animal lipids or similar compounds. However, at a certain level organic overload was reached resulting in process imbalances and inhibition conditions. In a few cases there was a complete stop in the process that necessitated re-inoculum addition and new feedstock supply. To avoid the risk of inducing this type of imbalance well performing biogas plants are today running with a medium biogas and methane yield. The biogas plants are monitoring selected control parameters to avoid organic overloading. Recent experiments with co-fermentations applying glycerol with mixtures of pig manure, maize silage, and rapeseed meal have shown a significant increase in the methane yield. To maintain a stable digestion process, the amount of glycerol should not exceed 6% (Amon et al., 2006). From these results it is evident that the glycerol can be advantageously applied, but a strict control strategy of the intermediate glycerol and fatty acid concentrations in the biogas reactor is needed to avoid the risk of organic overloading.

The most common measurement techniques applied in the biogas plant are simple on-line pH and temperature monitoring, as well as biogas flow measurements combined with off-line quantifications using high performance liquid chromatography (HPLC), gas chromatography (GC), and flow injection analysis (FIA). Different methods and equipment available for anaerobic digestion are presented in (Boe, 2006; Vanrolleghem and Lee, 2003). The simple on-line methods are however not able to predict process imbalances, and the off-line analyses are inefficient. Sample preparation is often time consuming with the result not being reached within a suitable timeframe and furthermore the analysis requires expensive equipment and skilled laboratory technicians. Hence the methods currently applied are inadequate for this complex task.

As means of obtaining better control and also to improve understanding of the process, process analytical technolo-

gies (PAT) may be invoked. PAT has been applied to a variety of applications within refineries, the food processing industries, and the pharmaceutical industries. It covers a wide array of process analytical methods (Bakeev, 2005), for example, on-line GC determination of volatile components (Boe, 2006; Diamantis et al., 2006), spectroscopy coupled to a flow system containing glycerol dehydrogenase for determining glycerol in wine (Fernandes et al., 2004) and near infrared spectroscopy for monitoring of acetate, glycerol, ammonium, and biomass in a recombinant *E. coli* production (Macaloney et al., 1997). Of the established methods, near infrared spectroscopy (NIR) seem to be the most promising solution as it is rapid and non-invasive. Furthermore, it requires no chemical addition and once calibrated by the help of multivariate data analysis it needs little maintenance except for system drift.

The main objective of this paper is to investigate the possibility of measuring the amount of glycerol and volatile fatty acids: acetic, propionic, iso-butanoic, butanoic, iso-valeric, and valeric acid and total-volatile fatty acids (VFA) in anaerobic fermentation bio slurry by on-line NIR. VFA can accumulate during the anaerobic digestion process and result in an increase that directly reflects the process behaviour and/or imbalances. The VFA concentration has been the intermediary compound suggested most often for monitoring anaerobic digestion processes (Ahring et al., 1995; Angelidaki et al., 2003; Hill and Holmberg, 1988). Several studies have pointed out that in addition to monitoring the total VFA behaviour, individual volatile fatty acids will also contribute towards improved understanding of anaerobic digestion (AD). The ratio between acetic acid and propanoic acid in the process can provide valuable information as an early warning before a process failure would occur (Boe, 2006; Hill and Holmberg, 1988). VFA are excellent compounds for indicating organic overload and the toxic condition where acid consumers and methanogens are inhibited; however, the VFA response is still unclear under toxic stress levels where acid producers are also inhibited—as under a high concentration of long chain fatty acids (Boe, 2006; Mladenovska et al., 2003).

A secondary objective is to obtain knowledge about the effect of different imbalances in the anaerobic digestion process, caused by the addition of glycerol. The concentration level of the added glycerol was studied, and how to balance or manage the process when it includes glycerol by-products from the biodiesel refinery processes.

## Materials and Methods

### Raw Materials

#### *Manure and Digested Manure*

The raw feedstock is mainly composed of manure and organic food industrial waste. Together with the inoculum needed for the AD process, both were collected from the

Ribe biogas plant in Southern Denmark. The inoculum biomass—the digested manure, was sampled at the main pipeline outlet from the thermophilic AD process. The digested manure was screened through a 3 mm sieve to eliminate all larger solid particles, necessary to avoid clogging in the on-line flow cell system in the trials reported below. The digestate was transported in insulated containers to avoid temperature decrease and microorganism disturbances. It was immediately inserted in the fermenters after delivery. The feedstock consisted of a typical substrate mixture, which was divided into 1 L portions and kept in the freezer before being fed into the bioreactors. It was defrosted before application and then heated up to 53°C—the specific thermophilic temperature level.

### Glycerol

Pure glycerol, was produced for laboratory purpose (J.T. Baker, purity: min. 99.5%), was injected regularly during the fermentation trials. It was decided not to use glycerol from biodiesel production plants with a varying content of water and impurities, in order to keep these factors neutral.

### Fermentation Trials

The anaerobic digestion process was carried out in three 5 L bioreactors (Simax, Sázava, Czech Republic) each with a working volume 4 L. Each of the fermenters could be connected to the on-line recurrent loop system, thereby enabling on-line analysis with the TENIRS measuring system, described in section: on-line NIR. A schematic view of the fermenter setup is shown in Figure 1. Stirring and heating were monitored and maintained by a program written in LabVIEW 8.0 (National Instruments, Austin, TX) software. Agitation was set to 30 rpm and the process was operated under stable thermophilic conditions, 53°C.

The trial lasted 33 days. The AD process worked initially for 13 days with systematic addition of standard feedstock in order to achieve a stable biogas production. The first measurements were carried out after this period; day number 1 thus corresponds to the first day of taking samples from the reactor. The reactor was operated in a semi-continuous mode – two times each day sampling and feeding with standard feedstock was carried out. The amount of substituted biomass was equal to 150 mL at each feeding time. The hydraulic retention time (HRT) was at 13.5 days. After 20 days the first portion of glycerol, mixed with the standard feedstock, was added. Table I shows the planned amount of glycerol and the theoretical concentration development in the fermenters. The purpose of increasing the addition of glycerol was first of all to increase the methane production, and later to provoke organic overloading in which the introduced amount of substrate was greater than consumed by the microorganisms. This would lead to a process imbalance and subsequently a final collapse of the fermentation process.

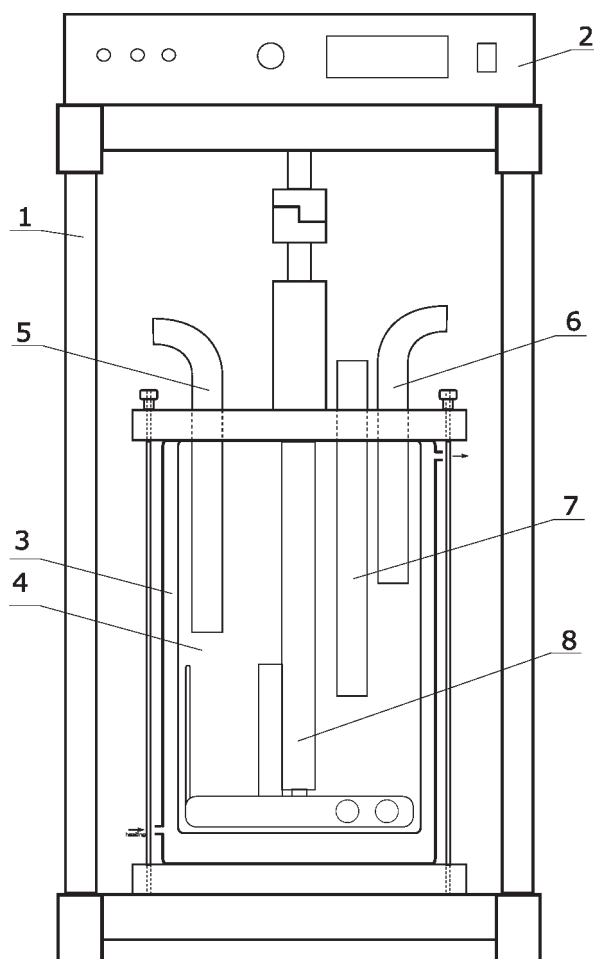

**Figure 1.** Fermentation setup: (1) holding frame; (2) stirring controller; (3) heating jacket with water; (4) 5 L glass fermenter; (5) outlet to TENIRS system; (6) inlet from TENIRS system; (7) feeding probe; (8) stirrer.

### On-Line NIR

The Transflexive Embedded Near InfraRed Sensor (TENIRS) system is a prospective at- and on-line measurement system utilized in flowing heterogeneous bioslurry systems. It was used in this trial as a semi on-line system, as it was moved from one fermenter to another during the trials. The TENIRS facility was developed by the Institute of Agricultural Process Engineering (ILV), at the University of Kiel for at-line measurements of bio-slurry and manure applications (Andree et al., 2005) to document that NIR spectroscopy can be a highly valuable tool for at- or on-line analysis of heterogeneous bioslurries such as pig and cattle slurry.

In this trial, the TENIRS loop was connected to each one of the three simultaneously running fermenters by the time. The loop was attached to the fermenter for approximately 30 min for each NIR measurements two times per day. During each NIR measurements, representative sampling of biomass were simultaneously performed for chemical

**Table 1.** Changes of glycerol concentration during conducted trials.

Day of trials	Amount of glycerol added to each fermenter (mL/day)	Theoretical change in concentration level in the fermenter (V/V%)
1–7	0	—
8–12	50	0.0 → 1.0
13–15	114	1.0 → 3.5
16–19	188	3.5 → 6.5

analysis. The *semi on-line attachment* was chosen because only one prototype of the TENIRS equipment and the sampling construction existed.

The loop was connected to the centre part of the fermenter by individual outlet and inlet pipes (see Figs. 1 and 2). From the outlet pipe the biomass was pumped through the loop by an integrated impeller pump and through the flow through cell for transflexive NIR spectroscopic measurements, then the loop continued passing through a special sampling device, see section: sampling, and finally back to the fermenter by the inlet pipe diametrically opposite the outlet pipe. The total length of the external piping loop was 230 cm with a pipe diameter of 2 cm. The loop was kept thermophilic, at constant 53°C, throughout the trial, by using insulation materials around the pipeline in the loop. In the flow through cell the height was adjusted to 3 mm, enabling NIR measurements where the cell width

expanded proportionally obtaining a constant pressure and flow in the pipe loop system. NIR data handling was organized with the software Aspect Plus, which allows communicating with the near infrared spectrophotometer Zeiss CORONA 45 NIR, with a scan range from 960 to 1,600 nm.

### Sampling

To obtain primary samples in agreement with the TOS; theory of sampling (Gy, 1998), a pilot device facilitating sampling from the on-line stream flowing through the TENIRS loop was developed and implemented directly after the TENIRS measuring cell (Fig. 2). By applying this configuration the samples were obtained from a one dimensional pipeline flow of the biomass compared to the full three

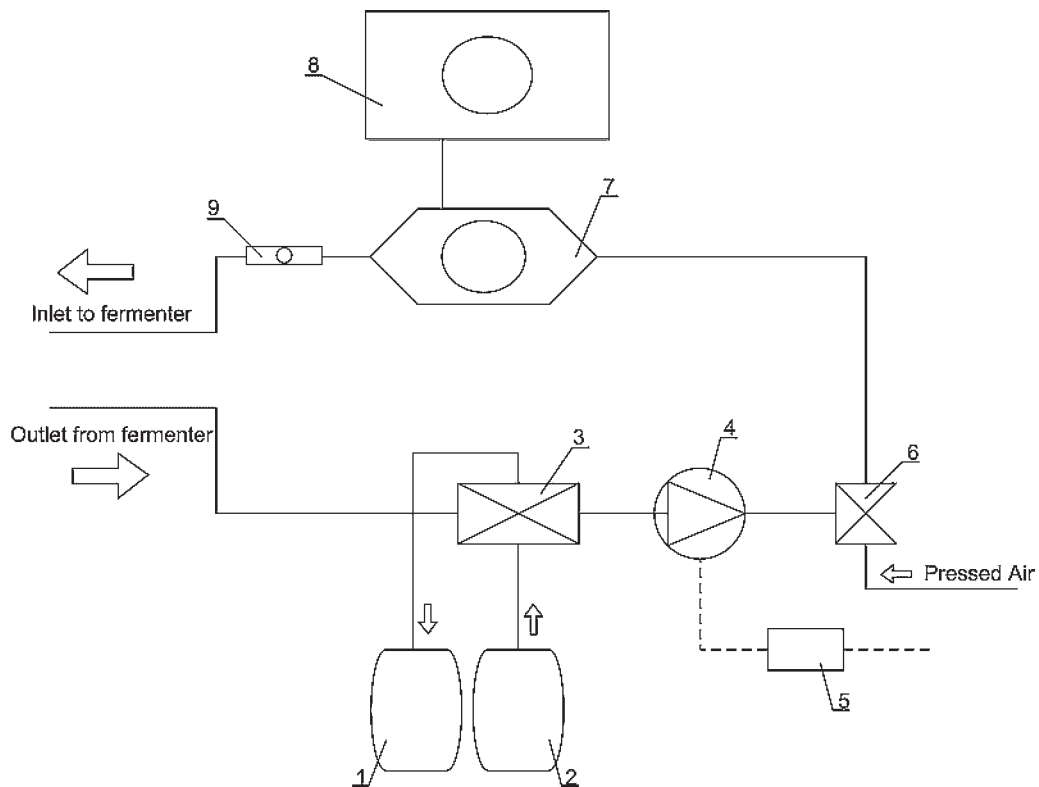

**Figure 2.** Recurrent measuring loop connected to fermenters: (1) outlet cleaning water; (2) inlet cleaning water; (3) multiway valve; (4) impeller pump; (5) frequency controller; (6) air valve, for drying after cleaning; (7) NIR flow-through cell; (8) Zeiss Corona NIR instrument; (9) sampling device.

dimensional section of the fermenter volume. The device (Fig. 3) consisted of a 10 mL bottle placed so, when a stainless steel disc was moved from side to side an incremental sample from the loop was sampled. Ten incremental samples were taken resulting in a primary 100 mL bio-slurry sample, insuring a composite sample (Gy, 1998; Mortensen, 2006; Pitard, 1993; Petersen, 2005).

This configuration was not completely in accordance with TOS as a total cross section of the flow in the pipeline was not completely ensured. This can only be obtained from an up-stream vertically flowing piping system. As a result the samples were slightly biased. However, this is a step in the direction for the development of a closed recurrent fermenter loop system.

## Chemical Analysis

### Total Solids/Volatile Solids

Total solids are a fraction of the total wet weight of a sample from which the water has been evaporated in an oven at 105°C for a period of 24 h. Total volatile solids were determined as the difference between total solids and the weight of the ashes from the sample kept in the oven for 2 h at 550°C.

### Glycerol Concentration

Glycerol concentration was determined using Ion Chromatography (Dionex Series 4500i with microinjection valve at 100–120 psi) with a CarboPac PA10 (4 × 250 mm) column. All samples were diluted in order to ensure a concentration in the area of 20–100 mg glycerol per litre and carefully filtered before injecting the 0.2–0.3 mL sample in the loop. Two eluents with a concentration equal to 140 and 200 mM NaOH were used.

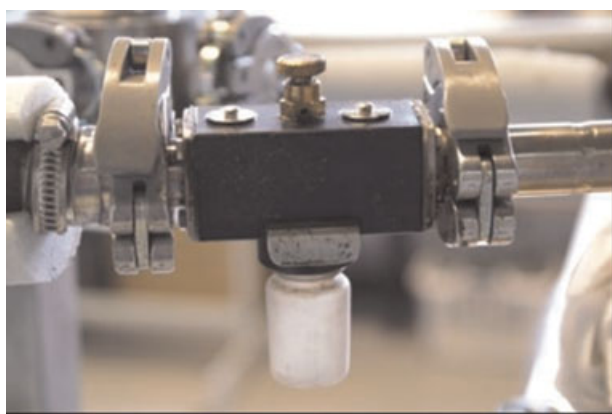

**Figure 3.** Prototype sampling device, 10 increments each of 10 mL were sampled during a period of 10 min. [Color figure can be seen in the online version of this article, available at [www.interscience.wiley.com](http://www.interscience.wiley.com).]

## Volatile Fatty Acids (VFA)

For all samples volatile fatty acids content was measured employing a GC/Varian 3800 chromatograph with a Varian 25 m 0.32 mm ID (Cat. No. CP 7488 WCOP fused silica coating FFAP-CB) column. The carrier gas had a constant heat pressure of 6 p.s.i., 2 mL of each sample was centrifuged, 200  $\mu$ L HCl 1 M and 2.0 mL Internal Standard solution: 2,2-dimethylbutanoic were added. Samples were separated in a Mediafuge at 5,000 rpm for 5–8 min. The separated sample was filtered through a 45  $\mu$ m acetate filter and injected into the GC. This method determined the individual concentrations of acetic, propanoic, isobutanoic, butanoic, isovaleric and valeric acid, and thereby also the accumulated total-VFA concentration.

## Data Processing

Chemometric data analysis gives an overview of the state of the chemical and/or biological processes based on analytical measurements. The idea of chemometrics is to let the process or the data structures unfold their relations themselves (Mortensen, 2006). From chemometric data analysis it is possible to decrease the required number of variables in order to describe the investigated phenomena.

In *multivariate calibration and validation* a large number of *X*-variables are used to correlate to a given reference (chemical or physical) variable (*Y*), for example, *X*: NIR spectra; *Y*: chemical reference variables. Partial Least Squares (PLS) regression was used with the scope to predict future *Y*-data directly from *X*-data. PLS-Regression (PLS-R) consists of three stages: model training—calibration, validation, and prediction (Esbensen, 2001; Martens and Næs, 1991).

A test set validation is a procedure for validation of a model by a completely independent data set—the test set. This is the strongest validation of any model, which was a real advantage in this study where trials were performed in three parallel independent fermenter systems. The results from the test set validation are much more reliable than any internally re-sampling of the training data set alone, such as cross validation.

Data obtained from the TENIRS system were modelled using the UNSCRAMBLER software (CAMO, ver. 9.5). Multivariate calibrations using Partial Least Square regression (PLS-1) were performed for quantitative determination of glycerol and total-VFA as well as for the individual acids as acetic, propionic, iso-butyric, butyric, iso-valeric, and valeric acids. For each chemical component a separate model was set up. In all cases the models were evaluated by a comprehensive test set validation applying fermentation No. 1 and 3 as the calibration set respectively and No. 2 as the test set. The analysis includes best models obtained by the lowest numbers of principal components (PC), and by carefully removal of a minimum of outliers in the models (Esbensen, 2001).



## Results and Discussion

The anaerobic digestion trial was performed in triplicate, lasting for 33 days; during the first 13 the process was stabilized. These days were excluded from further analysis, not included in the glycerol spiking trials. Sampling and chemical analysis was performed twice a day for the rest of the trial period (days 1–19). Each sample was analyzed for glycerol, VFA, and TS/VS content. Additionally, NIR spectra of the flowing biomass were acquired for the PLS-1 models (X). All results are presented in the sections below.

### Chemical Analysis

The changes in the glycerol concentration in the bioreactor in the full experiment are presented in Figure 4. In the beginning of the glycerol addition, no accumulation was observed, which indicated that the microorganisms were able to degrade it to biogas. The increase in the feeding level at day 12 however, resulted in a slow accumulation, which became more pronounced when the feeding level was increased further at day 16. The overall accumulation of glycerol from the 16th to the 19th day of the trial, was from approximately 5 to more than 30 g L<sup>-1</sup>, indicating that a severe organic overload might be taking place. The organic overload was caused by a bottleneck in the system, where the slowest process in the degradation chain, was determining the overall speed of the process, consequently the substrate was accumulated in the reactor.

The overall tendency in the VFA concentrations in the fermenter increased simultaneously and even faster than the

increase in the glycerol concentration (Fig. 5), thus indicating that the organic overload taking place was due to an inhibition of the methanogenic step. A slow accumulation of the VFAs was observed already at the 8th day. After the 12th day the VFA-acids content grew rapidly achieving the highest level: 36 g L<sup>-1</sup> in fermenter no. 2. From days 12 to 16 organic overloading occurred, and after day 16 the process was strongly imbalanced and no biogas production was noticed. The acetic acid concentration, seen in Figure 6, was the most important contributor to the total VFA concentration, which means that exactly the same tendencies were seen in the acetic acid concentration behaviour during the trial (Fig. 6).

When VFA concentration significantly exceeds 5.0 g L<sup>-1</sup>, the AD process is no longer stable and organic overloading is likely (Amon et al., 2006). Due to medium to high daily doses of glycerol since day 13, increasing VFA contents continued to imbalance the process ending by complete collapse. This can be seen when VFA concentration exceed 10–12 g L<sup>-1</sup> (Fig. 5). Exactly the same tendencies can be seen in the acetic acid concentration development (Fig. 6).

Contemplating both the glycerol and the VFA and acetic acid results, it was seen that the VFA and acetic acid concentration increased earlier, compared to the concentration of glycerol, thus giving an early warning of the coming process instabilities. For this reason the VFA can be applied in the context of process monitoring and controlling.

According to Angelidaki et al. (2002) the VFA concentrations in biogas production do not necessarily have to be directly toxic to the process, but it indicates imbalance of

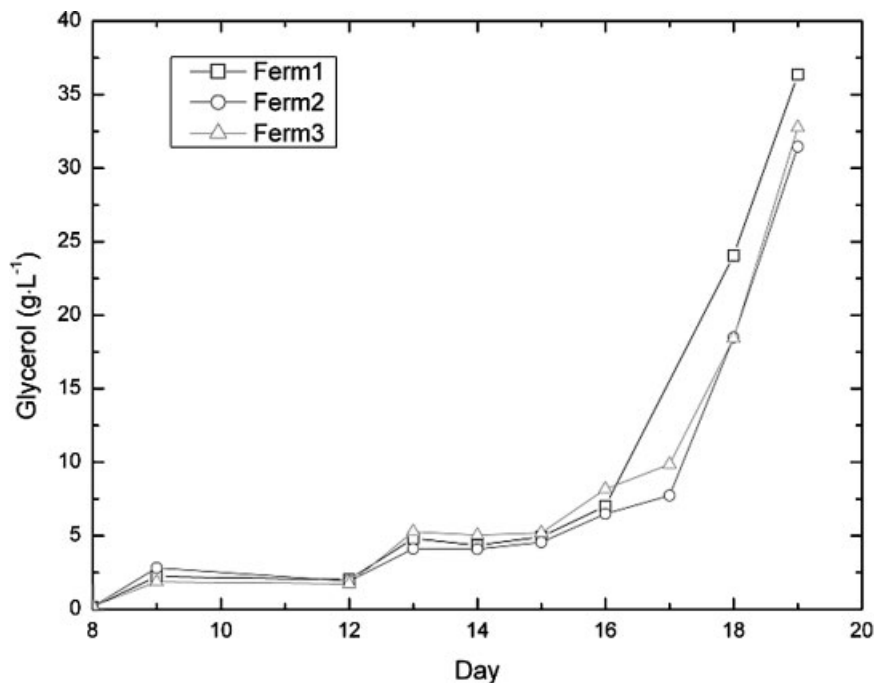

**Figure 4.** Glycerol development during the AD process trials, shown for each individual fermenter.

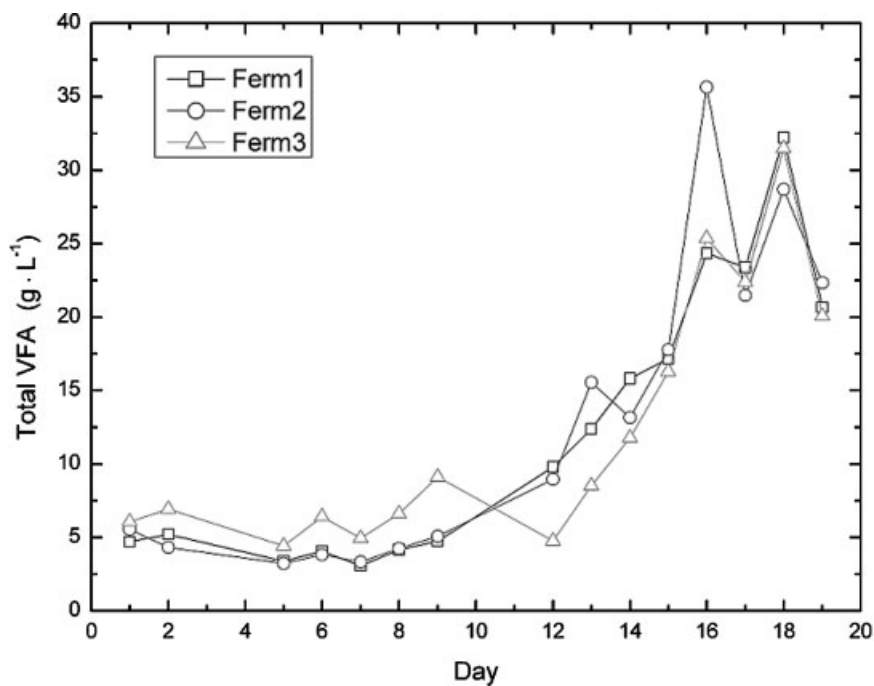

**Figure 5.** Volatile fatty acids contents. Development for each fermenter.

the process. Therefore, the increase of VFA is usually the result of process imbalances, not the reason, but can nevertheless give an important early warning of imbalances in progress.

Glycerol is a very promising feedstock for increasing biogas yields when the concentration does not exceed 5–7 g/L inside the digesters. Above this concentration level organic overloading occurs and methane is produced at a significantly

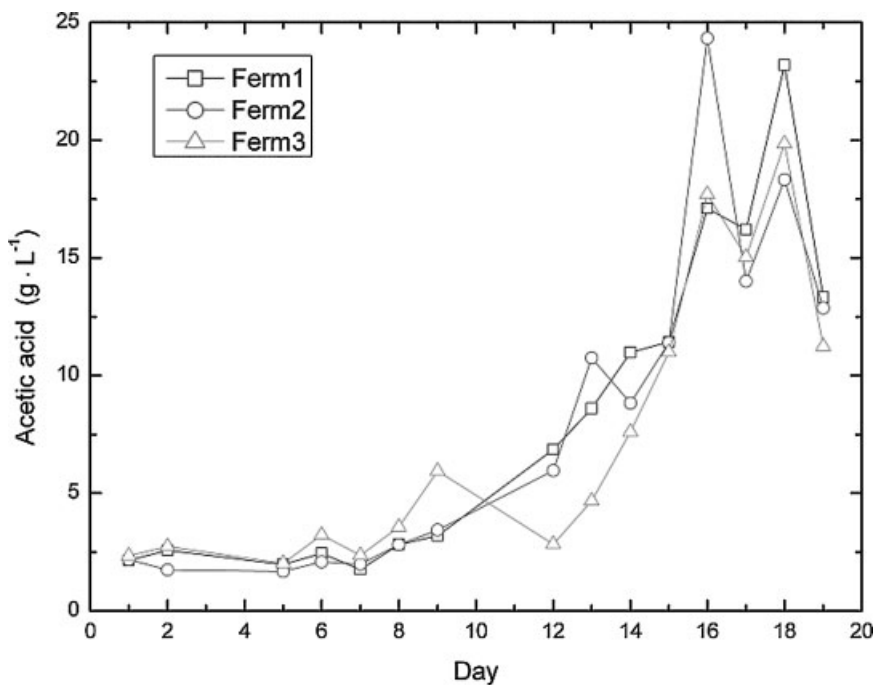

**Figure 6.** Acetic acid concentration changes during the investigated trial.



lower rate or could even be stopped. A longer adaptation period for the microorganisms may sometimes allow a higher feeding rate of glycerol in the anaerobic digestion process. In a full scale mesophilic biogas plant operation, the Hashøj biogas plant in Denmark, up to 9 vol.% glycerol has been registered for the feedstock blend, producing very high biogas yields.

At thermophilic conditions at  $53^{\circ}\text{C} \pm 3$  vol.% has been registered as a glycerol concentration which is fairly easy to manage. Above this concentration level a decrease in biogas production can occur or other measures shows organic overloading by increasing the VFA concentration during the fermentation. Similar results have been documented by Amon, (2006), indicating that a significant increase in the methane yield can be achieved with the addition of up to 6% of glycerol. However, further addition inhibits the process. This study has indicated fully that such a feeding situation can occur if no on-line process measures or proactive feeding management plan has been set in operation.

Several volatile acids were monitored in the present study. VFA changes constitute the most important indicators of early warning of process imbalances. High concentration is a

sign of severe stress of the microorganisms and most likely organic overloading. An indication of VFA imbalances started between days 12 and 13 (Fig. 5). Severe organic overloading occurred on the 16th day of the trial when the concentration exceeded approximately 11.5 g/L and 18.0 g/L of acetic acid and total VFA, respectively. In the present study the organic overloading was however caused by purpose in order to achieve as wide a span as possible of acid concentrations allowing for PLS-1 models with high validations in all relevant ranges of volatile fatty acid concentrations.

### Multivariate Calibration and Validation of On-Line NIR spectra

A PLS-1 model of glycerol concentration in the fermentation bio slurry, measured two times daily during the fermentation trial, showed very good performance (Fig. 7). The linear regression relationship needed primarily two PLS components to model the glycerol  $Y$ -variables measured at the Ion Chromatography equipment from the  $X$ -variables (NIR).

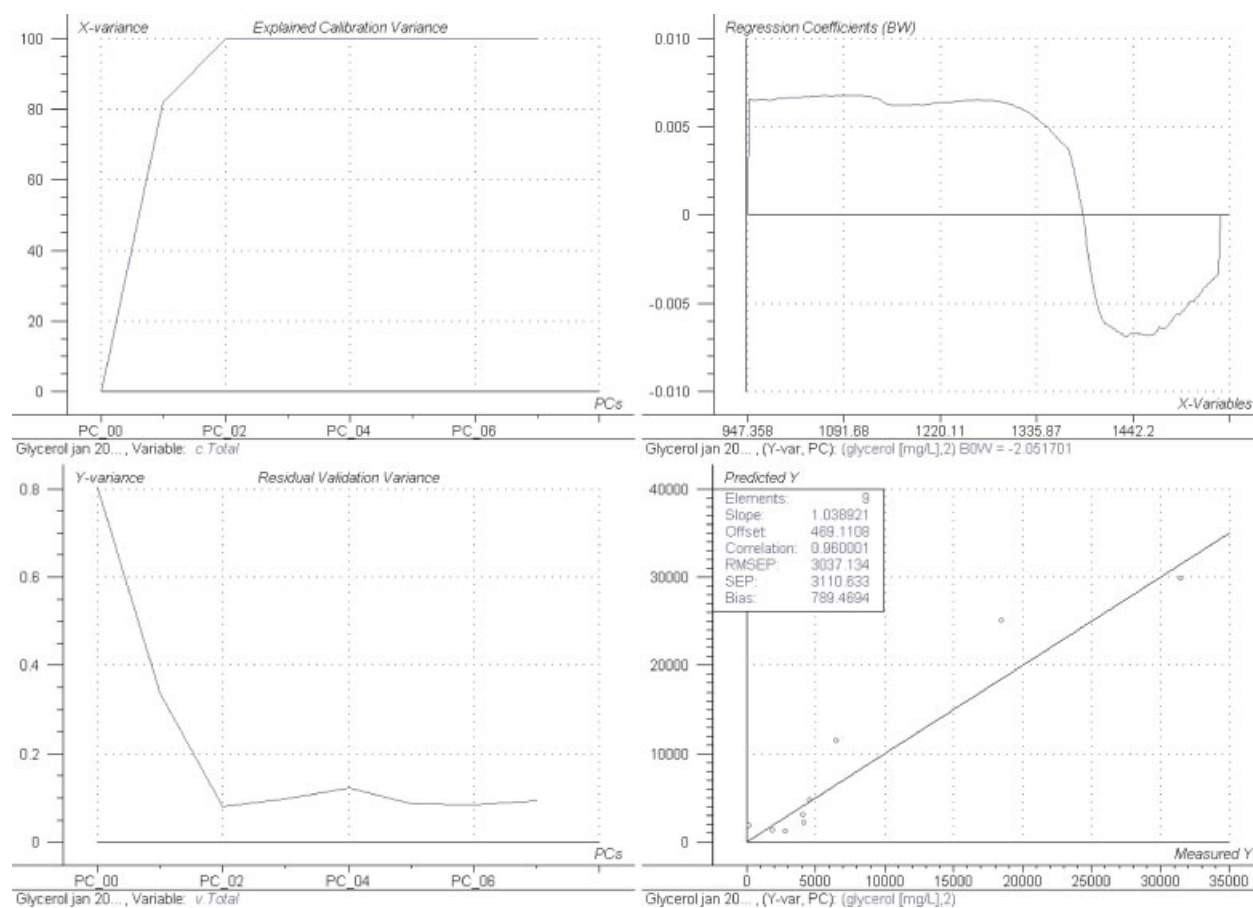

**Figure 7.** Glycerol PLS-1 model; number of required PLS components = 2; One outlier was removed; Test set validation was made from data obtained in fermenter No.2 and tested against data from fermenter No.1 and No.3; Measures of precisions  $r^2 = 0.96$  and slope 1.04. [Color figure can be seen in the online version of this article, available at [www.interscience.wiley.com](http://www.interscience.wiley.com).]

**Table II.** Overview of PLS-1 models for volatile fatty acids; root square error of prediction (RMSEP).

	Acetic	Propanoic	Iso-butanoic	Butanoic	Iso-valeric	Valeric	Total VFA
No. of PCs	3	1	4	5	6	3	4
Explained validation variance (%)	93.1	54.8	89.3	92.7	92.8	86.3	94.0
No. of outliers	2	1	4	4	2	4	2
RMSEP	1,476	1,364	26.46	271.9	55.83	24.31	2,095
RMSEP/mean measurement level (%)	14.8	32.2	12.1	22.2	19.2	13.1	12.9
Correlation ( <i>r</i> )	0.98	0.37	0.95	0.74	0.97	0.93	0.98

Definitions according to Esbensen (2001): PCs—are composite variables, that is, linear functions of the original variables, estimated to contain, in decreasing order, the main structured information in the data; Outlier—an observation (outlying sample) or variable (outlying variable) which is abnormal compared to the major part of the data; RMSEP—root mean square error of prediction—a measurement of the average difference between predicted and measured response values, at the prediction or validation stage; correlation—a unitless measure of the amount of linear relationship between two variables; the correlation is computed as the square root of the covariance between the two variables divided by the product of their variances. It varies from  $-1$  to  $+1$ .

All the fatty acids were modelled by PLS-1 analysis in Unscrambler like the above model of glycerol. The results are summarized in Table II. As examples two models are shown below; acetic acid (Fig. 8), as a main contributor of the total VFA, and iso-butanoic acid (Fig. 9) as a minor fatty acid analogue, presumably more difficult to model due to its very low concentration levels. Finally a model of total VFA was shown (Fig. 10). This was done to document the

strength in the application possibilities of NIR measurements.

The PLS-1 prediction model for acetic acid showed that the validation fermenter No.2 provided a realistic validation basis. The linear regression relationship needed 3 PLS components to model the Y-variable: acetic acid concentration analysed at the HPLC, from the X-variables (NIR). The overall model for acetic acid showed a very strong

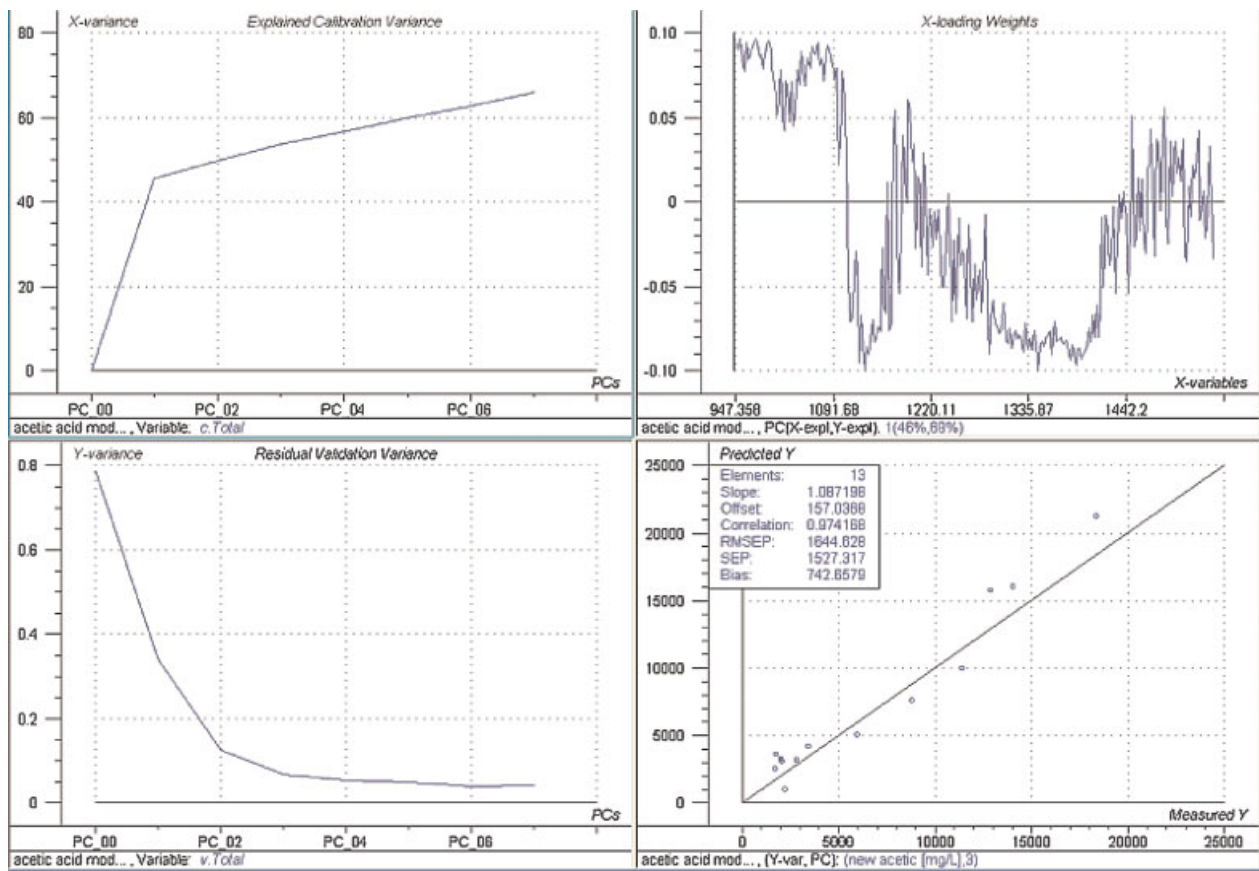

**Figure 8.** Acetic acid PLS-1 model; number of PLS-components required = 3; Two outliers were removed; Test set validation where data from the fermenter No.2 were tested against calibration data from fermenter No.1 and No. 3; measures of precision:  $r^2 = 0.95$ , and accuracy; slope = 1.09. [Color figure can be seen in the online version of this article, available at [www.interscience.wiley.com](http://www.interscience.wiley.com).]

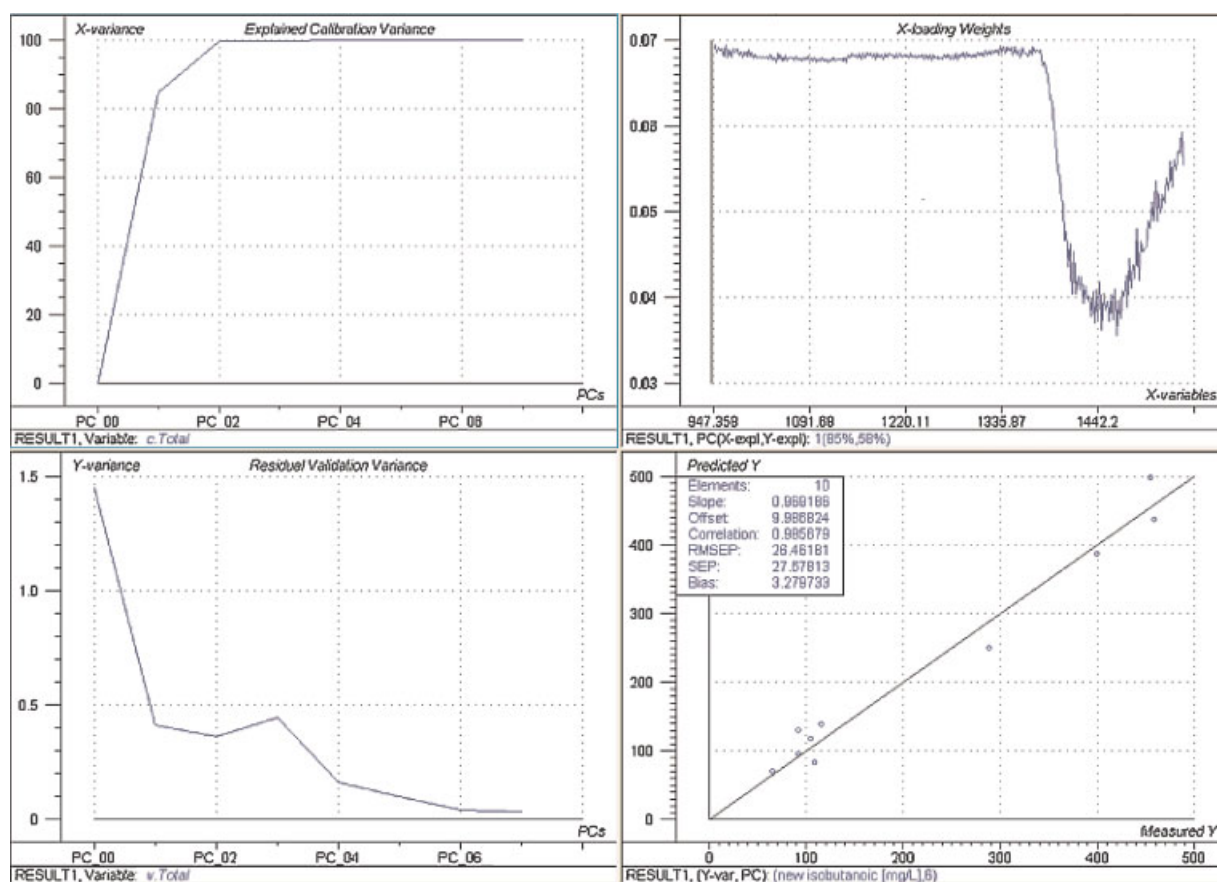

**Figure 9.** Iso-butanoic acid PLS-1 model; number of required PLS components = 6; Four outliers were removed; Test set validation of data from the fermenter no. 2; measures of precision:  $r^2=0.97$  and accuracy; slope = 0.97. [Color figure can be seen in the online version of this article, available at [www.interscience.wiley.com](http://www.interscience.wiley.com).]

correlation between the HPLC measurements and the on-line NIR measurements. As acetic acid was the main contributor to the total VFA, the model obtained for total VFA showed, not surprisingly, the same trends with respect to the loading weight plot and the calibration and validation variance as the model for acetic acid (Table II).

The PLS-1 prediction model for iso-butanoic acid in the three bio-slurry fermenters spiked with glycerol showed a good validation model. For fermenter No.2 test set validation showed good statistic precisions;  $r^2=0.97$  and the accuracy of predicting iso-butanoic acid by NIR had a slope of 0.97.

The PLS-1 prediction model for total VFA in the three bio-slurry fermenters spiked with glycerol provided a very good validation model. Test set validation showed good statistic precisions, see Figure 10. The on-line trials have been useful to document the possibilities to measure total VFA conditions during increased feeding of concentrated feedstock's like the glycerol in the anaerobic digestion systems to optimize the biogas production.

Table II gives an overview of all PLS-1 models computed for the main compounds of volatile fatty acids. The statistics show that the weakest model was developed for propanoic

acid which was not acceptably, while all other VFA could be statistically modelled, Y-variance modelled span 86–94%.

Biogas production yields in volume and quality will always be some of the most important parameters to indicate overall process and reactor performance, but one weakness is that these parameters cannot give an early warning and indication of the stress status of the fermentation behaviour. The future combination with on-line monitoring of the VFA and other important intermediates like ammonium will provide extremely valuable information for improved process control as is documented in this study.

## Conclusion

Due to high growth rates in the biodiesel production capacities in Europe and world-wide, glycerol is increasing in amounts year by year. The availability of glycerol for many industrial purposes is increasing. One of the sectors that have had increasing production and utilisation capacity growth rates is the European biogas sector. The co-digestion

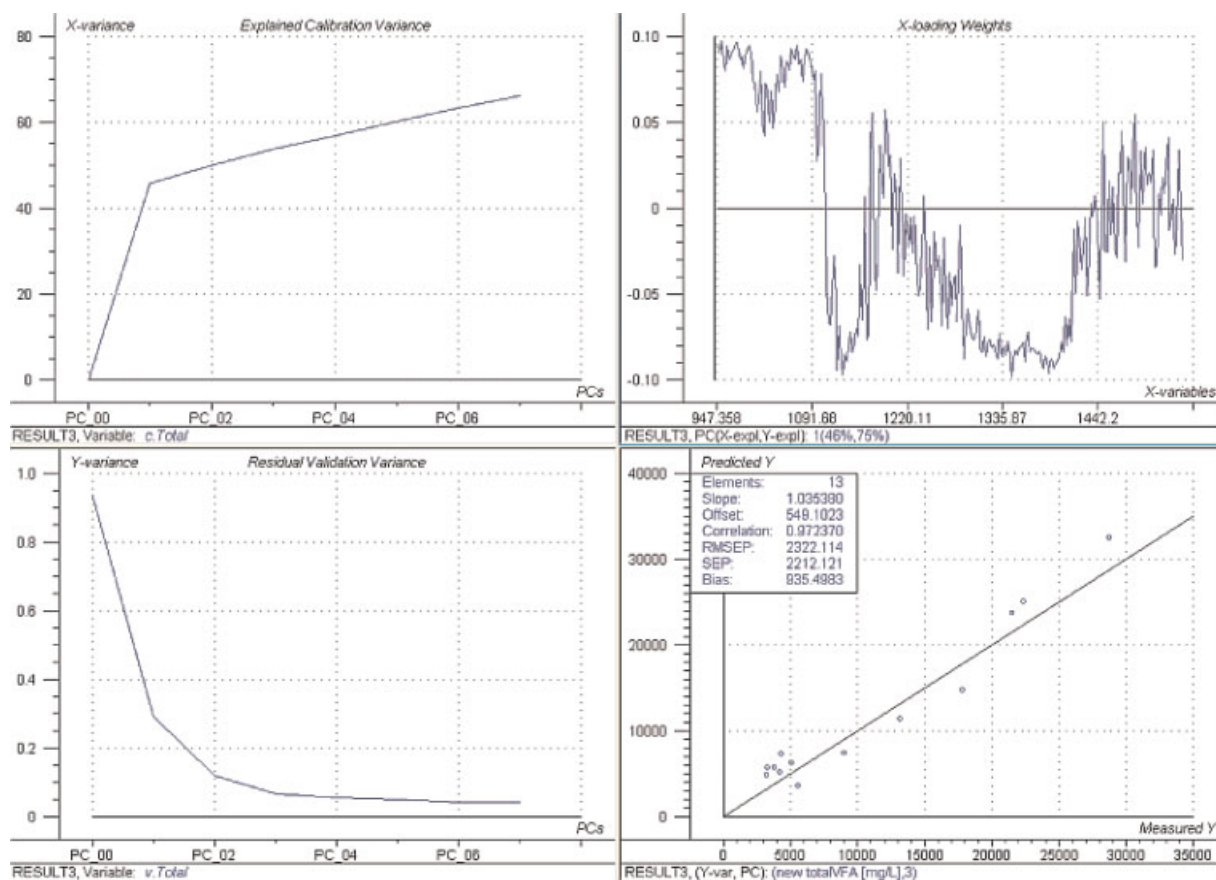

**Figure 10.** Total VFA PLS-1 model; number of required PLS-components = 3; Two outliers were removed; Test set validation where data from the fermenter No. 2 were tested against calibration data from fermenter No. 1 and No. 3; measures of precision:  $r^2 = 0.98$ , and accuracy; slope = 1.03. [Color figure can be seen in the online version of this article, available at [www.interscience.wiley.com](http://www.interscience.wiley.com).]

of high yielding glycerol with a range of other feedstock's like manure and energy crops are rising in importance.

Spiking trials have shown that glycerol at concentration levels of  $3\text{--}5\text{ g L}^{-1}$  makes the anaerobic digestion process run at continuously stable conditions. On-line measurement of the fermentation process has documented that with low concentrations of glycerol the VFA and the individual fatty acids show no sign of organic overloading. However, when rapidly increasing the content of glycerol, there are clear tendencies of organic overloading.

The results concluded a good correlation between on-line NIR measurement of glycerol and the VFA content in the anaerobic digestion process and analytical laboratory results. On-line process monitoring control is becoming more and more important when anaerobic digestion processes are spiked with concentrated feedstock, like glycerol. Analytical tools as applied in these experiments will bring forward the needed information of early warning about process imbalances.

The investment in the fermenters was made possible by the Esbjerg Seminarium Foundation and equal match funding by Aalborg University.

## References

- Ahring BK, Sandberg M, Angelidaki I. 1995. Volatile fatty acids as indicators of process imbalance in anaerobic digestors. *Appl Microbiol Biotechnol* 43:559–565.
- Amon T, Amon B, Kryvoruchko V, Bodirosa V, Potsch E, Zollitsch W. 2006. Optimising methane yield from anaerobic digestion of manure: Effects of diary systems and of glycerine supplementation. *Int Congr Ser* 1293:217–220.
- Andree H, Dolud M, Hügler T. 2005. TENIRS—NIR analysis of heterogeneous bioslurries. In: Madsen M et al., editors. *Baltic Biorefinery Symposium, proceedings*, p 141–148.
- Angelidaki I, Ellegaard L, Sorensen AH, Schmidt JE. 2002. Anaerobic processes. In: Angelidaki I, editor. *Environmental biotechnology. Environment & Resources*. The Technical University of Denmark. p 1–114.
- Angelidaki I, Ellegaard L, Ahring BK. 2003. Applications of the anaerobic digestion process. In: Ahring BK, editor. *Biomethanisation II*. Berlin, Germany: Springer. p 1–33.
- Bakeev KA, editor. 2005. *Process analytical technologies*. Oxford: Blackwell Publishing. p 1–11.
- Boe K. 2006. On-line monitoring and control of the biogas process. Institute of Environment and Resources, DTU. Ph.D. Thesis.
- Bournay L, Casanave D, delfort B, Hillion G, Chodoroge JA. 2005. New heterogeneous process for biodiesel production: A way to improve the quality and the value of the crude glycerine produced by biodiesel plants. *Catal Today* 106:190–192.

- Diamantis V, Melidis P, Aivasidis A. 2006. Continuous determination of volatile products in anaerobic fermenters by on-line capillary gas chromatography. *Anal Chim Acta* 573–574:189–194.
- Esbensen KH. 2001. Multivariate data analysis—In practice. An introduction to multivariate data analysis and experimental design. Aalborg University Esbjerg. Camo Process AS, Norway.
- Fernandes EN, Campos Moura MN, Lima JLFC, Reia BF. 2004. Automatic flow procedure for the determination of glycerol in wine using enzymatic reaction and spectrophotometry. *Microchem J* 77:107–112.
- Gy P. 1998. Sampling for analytical purposes. Chichester: John Wiley & Sons.
- Hill DT, Holmberg RD. 1988. Longchain volatile fatty acid relationships in anaerobic digestion of swine waste. *Biol Waste* 23:195–214.
- Mandil C, editor. 2004. Biofuels for transport an international perspective. Chirat, France: International Energy Agency. p 25–47.
- Macaloney G, Halls JW, Rollins MJ, Draper I, Anderson KB, Preston J, Thompson BB, McNeil B. 1997. The utility and performance of near-infrared spectroscopy in simultaneous monitoring of multiple components in a high cell density recombinant *Escherichia coli* production process. *Bioprocess Eng* 17:157–167.
- Martens H, Næs T. 1991. Multivariate Calibration. Updated version. Chichester, UK: John Wiley and Sons.
- Mladenovska Z, Dabrowski S, Ahring BK. 2003. Anaerobic digestion of manure and mixture of manure with lipids: Biogas reactor performance and microbial community analysis. *Water Sci Technol* 48:271–278.
- Mortensen PP. 2006. Process Analytical Chemistry—Opportunities and Problems for Bio-industrial Implementation. Aalborg University Esbjerg. Ph.D. Thesis.
- Nielsen LH, Hjort-Gregersen K, Thygesen P, Christensen J. 2002. Socio-economic Analysis of Centralised Biogas Plants. Report no. 136. Danish Ministry of Food Agriculture and Fisheries.
- Petersen L2005. Pierre Gy's Theory of Sampling (TOS) in Practice: Laboratory and Industrial Didactics. Aalborg University Esbjerg. Ph.D. Thesis.
- Pitard FF. 1993. Pierre Gy's sampling theory and sampling practice, 2nd edition. Boca Raton, FL: CRC Press Ltd.
- Vanrolleghem PA, Lee DS. 2003. On-line monitoring equipment for wastewater treatment processes: State of art. *Water Sci Technol* 47(2): 1–34.

# Paper IV

Jens Bo Holm-Nielsen, Karina J. Larsen, Helene Møller, Henrik B.Møller,  
Stephen Njoku, Ludovic Boland, Michael Madsen and Kim H. Esbensen

*Process Analytical Technology - monitoring of biogas processes  
at Meso- and Full-Scale Biogas Plants.*

Submitted May-2008 to Journal of Biotechnology and Bioengineering, Wiley Periodicals, Inc.





## Process Analytical Technology: - Monitoring of Biogas Processes at Meso- and Full-Scale Biogas Plants

Jens Bo Holm-Nielsen<sup>1\*</sup>, Karina J. Larsen<sup>1</sup>, Helene Møller<sup>1</sup>, Henrik B. Møller<sup>2</sup>, Stephen Njoku<sup>1</sup>, Ludovic Boland<sup>1</sup>, Michael Madsen<sup>1</sup> and Kim H. Esbensen<sup>1</sup>

1) Aalborg University, Esbjerg Institute of Technology, ACABS Research Group,  
Niels Bohrs Vej 8, DK-6700 Esbjerg, Denmark,  
tel.: (+45) 9940 7666, mobile: (+45) 2166 2511, [www.acabs.dk](http://www.acabs.dk);

2) University of Aarhus, Faculty of Agricultural Sciences, Department of Agricultural Engineering;  
[www.agrsci.dk](http://www.agrsci.dk);

\*) e-mail address for corresponding author: [jhn@aaue.dk](mailto:jhn@aaue.dk)

*Submitted May-2008 to Journal of Biotechnology and Bioengineering, Wiley Periodicals, Inc.*

### Abstract

Biogas plants converting animal manure materials and other biomass products by anaerobic digestion (AD) are among the cheapest and most effective tools for achieving post-Kyoto targets concerning reduction in the emission of greenhouse gases of CO<sub>2</sub>, CH<sub>4</sub>, N<sub>2</sub>O. Focus in this study is on meso- and full-scale biogas plant implementation of Process Analytical Technologies (PAT) to develop chemometric multivariate calibration and prediction models for on-line monitoring and control of the anaerobic digestion process in a re-current loop modus. The larger goal is to prepare for implementation of on-line monitoring and control applications in the biogas and biorefinery sectors, in order to be able to adjust the process according to the varying demands in the bioenergy and sustainable products market.

Most studies reported in the literature have investigated near infrared spectroscopy (NIR) in laboratory-scale or minor pilot biogas plants; only very few studies exist for on-line process monitoring of full-scale biogas plants. It is here necessary to obtain a fairly constant level of VFA concentration which leads to a stable biogas production. VFA concentration levels should not exceed 4-5000mg/l. On-line control and management of VFA concentration levels can speed up or slow down the AD-process. We present two case studies:

Case 1 - "Bygholm trials": By comparing pilot plant NIR-spectra to laboratory VFA reference concentrations at the experimental locality *Bygholm*, it was possible to develop highly satisfactory calibration models by Partial Least Squares (PLS) regression, i.e. acceptable to very good PLS-prediction models for total VFA as well as for all essential individual acids. The average statistics assessing prediction performance, accuracy (slope-value) and precision: correlation ( $r^2$ ), were both 0.92. VFA contents had a significant impact on biogas production.. Bygholm studies took place in a meso-scale 150 L bioreactor.

Case 2 - "Linkogas trials": For full-scale PAT-implementations, primary sampling representativity is critical and needs continuing improvement as shown in this study. To



meet complete satisfaction it is needed to introduce automated sampling devices at optimal placements in the process. The *LinkoGas biogas plant* has a naturally low VFA concentration level due to the feedstock composition consisting primarily of cattle and pig manure and food waste. This brings forth challenges in gathering reference samples for multivariate calibration and validation. It is mandatory that samples in particular reflect the expected *future* variability of the substrate. Prediction precision ( $r^2$ ) in the developed multivariate model of VFA was also here 0.92 while accuracy (slope) was 0.83, also a fully acceptable model taking the inherent heterogeneity and complexity of the system into account. The Linkogas bioreactors are of size 2400 m<sup>3</sup>. The present results helps in developing affordable, robust non-invasive PAT technologies dedicated for regulation of all major types of biogas plants as well as biorefineries world-wide.

**Keywords:** on-line monitoring, Near InfraRed spectroscopy (NIR), anaerobic digestion (AD), volatile fatty acids (VFA), Process Analytical Technologies (PAT), representative Sampling, Theory of Sampling, (TOS), Biogas Production, Biorefinery.

### **Introduction**

Biomass can be looked upon as a source for sustainable, environmental-friendly, clean energy. One approach for utilisation of biomass that has gained much attention over the past years is processing in the biotechnological refinery. Analogous to a petrochemical refinery producing a wide variety of products from crude oil, the same principles can be applied to a biomass-based refinery. This biotechnological approach exerts some fundamental advantages compared to classical chemical synthesis. Low process temperature, low energy consumption, and high product specificity are the most important features [Thomsen 2005]. The term *biorefinery* has been defined the following way by the United States Department of Energy:

*“A biorefinery is an overall concept of a processing plant where biomass feedstock are converted and extracted into a spectrum of valuable products”*, [Kamm et al. 2006]

In other words, a biorefinery has the capability of using multiple substrates for production of various value-added products. Moreover, by-products generated in one part of the biorefinery can serve as substrates in another process module. This is apparent for instance when integrating production of liquid biofuels with biogas. The digested biogas substrate can be separated into a liquid fraction, which is an efficient organic fertiliser rich in Nitrogen and Potassium nutrients and a solid lignocellulosic Phosphorous fibre fraction suitable for harsh treatment, enzymatic hydrolysis, and subsequent fermentation yielding ethanol, an alternative transport fuel in great demand, the solid fraction has several alternative treatment routes. The term *waste product* is therefore more or less non-existing in the context of biorefining.

Biogas technology can be applied for very many purposes including production of renewable energy, sustainable utilisation of agricultural biomass resources, and environmental protection through treatment of wastewater. In the context of renewable energy production, organic substrates are degraded in the absence of air, under anaerobic conditions, producing biogas which is a mixture of methane and carbon dioxide in the gaseous phase, and a nutrient-rich liquid fertiliser applicable for crop cultivation in the liquid phase.

Biogas plants are a new class of versatile bioconversion processing plants that can be implemented and optimised for various purposes. For energy production, biogas plants are capable of treating organic waste, energy crops, and agricultural residues. In the context of wastewater treatment, biogas technology can be applied for removing persistent organic pollutants and thus clean up and/or secure the water environment. In order to be able to operate biogas processes reliably and swiftly, there is a need for comprehensive monitoring. Otherwise the semi continuously process may soon become imbalanced due to hydraulic - or organic overloading, which can lead to severe economic losses, if not complete biological systems breakdown.

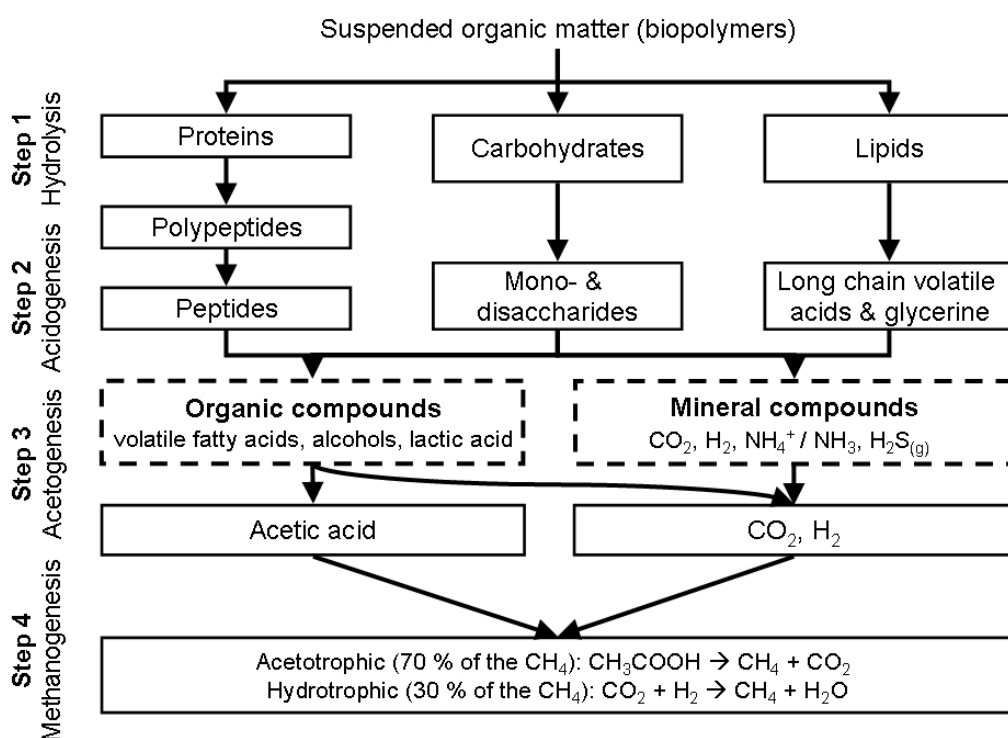

Figure 1. Schematic diagram of the complex of anaerobic degradation processes degrading organic matter. The dashed boxes indicate important compounds in both the gaseous and in the liquid phase that can be used for advanced on-line process control. Graphics adapted in modified form from [Benabdallah El-Hadj 2006]

Biogas plants are among the cheapest and most effective Kyoto-tools for energy production and integrated processing. The water environment will benefit from better controlling and recycling nutrients to cropland by optimal utilization of Nitrogen and Phosphorous. Hence, less harm will occur to the aqueous environments as surveyed in the 1990s by [Holm-Nielsen et al. 1993, 1997, Nielsen et al., 2002]. Last, but not least, hygienic restrictions and precautions for ensuring animal health can benefit from these biotechnological tools as well. Handled correctly, animal by-products, animal manure, and societal by-products containing viruses, bacterial diseases and other harmful microorganisms can be sanitised and their energetic and nutritional potential more fully

explored in the agricultural sector. Veterinarian and hygienic aspects are evaluated in [Böhm et al. 1999, Baggesen et al. 2007].

Future biogas technology concepts, enabling economically feasible plants based on animal manure alone have been evaluated by [Christensen et. al., 2007]. At present, the Danish biogas sector is dependent on the availability of quality organic wastes, containing sufficient amounts of lipids in order to guarantee a profitable production from co-digestion with manure. However, the market for quality organic waste is under heavy pressure, resulting in significantly increasing prices. A new energy plan has been accepted in the Danish parliament, February 2008, which means the biogas sector will increase rapidly in the coming decade. Future biomass resources to be processed in the biogas sector will be comprising of animal manure, energy crops and crop residuals, food and feed waste, and quality organic waste from the society, and by quality control measures [Al-Seadi et al. 2001].

The research work reported here is a continuation of two major studies initiated and reported by Holm-Nielsen et al. (2007a, 2007b). Focus is first on implementation of Process Analytical Technologies (PAT) at a meso-scale research fermentor (150 L) at Aarhus University, *Bygholm – Case 1*. Second, at an operating full-scale biogas plant (2400 m<sup>3</sup>). In both cases the goal was to develop chemometric multivariate calibration models for on-line monitoring. The *Case 2 - Linkogas* study is a continuing study initiated in early 2007 at Linkogas a.m.b.a., situated nearby Roedding, Southwest Jutland, Denmark.

Biogas production technology is one of the most flexible and adjustable renewable energy technologies available due to the integrated long-term storage possibilities of carbon source in the feedstock, requiring only a minimum of pre-treatment, exemplified by crop-silage storing. This advantage clearly differentiates biogas from other renewable energy sources and technologies. The search is on for the most efficient and reliable whole-process monitoring approach. VFA has so far received the largest interest, but in coming monitoring studies, ammonia inhibition will be surveyed as well. Both related parameters, VFA concentration level and ammonia concentration are highly suited for advanced monitoring and control of bioconversion process in general, biogas processes in particular.

## **Case 1: Bygholm - 150 L research fermentor**

### **Introduction**

This case study concerns on-line PAT-monitoring of an anaerobic digestion (AD) fermentation process at a meso-scale biogas plant, a 150 L research reactor. In the bio-energy sector, on-line monitoring solutions must be practical, efficient and inexpensive in order to accommodate the necessary, very strict cost efficiency demands in this bulk handling industry sector. It is therefore of prime interest to develop approaches, procedures, equipment, which fulfils these requirements while delivering a sufficiently complete characterization of the heterogeneous biomass. The aim of this case study was to test if changes in biomass composition - due to changes in operating conditions by organic overloading and temperature increase - could be satisfactorily detected by on-line near infrared (NIR) spectroscopy. For this, a newly developed integrated approach,

the TENIRS-system together with representative sampling was put to stringent tests, (Holm-Nielsen et al. 2007, Holm-Nielsen et al. 2008).

### Experimental plan

The objective in particular was to develop a multivariate calibration model for prediction of the concentrations of VFA. This was accomplished by use of TENIRS' on-line NIR measurements during experimental spiking trials. The critical success factor was here to ensure a sufficiently wide compositional span in the calibration data set. For this goal it was planned to introduce stepwise operational changes in the specific AD feeding and operational conditions. The test period was divided into 4 stages. Each stage lasted approximately 1 week.

**Stage 1.** Stage 1 represents normal operational conditions with the purpose of identifying the initial level of VFA concentrations pertaining to the specific load composition in this system. The standard feeding rate was 5 kg pig manure feedstock, fed twice a day. Temperature level was fixed at 51 °C.

**Stage 2.** Stage two employed a doubling in feeding rate - 5 kg pig manure, four times per day, every 6 hours. The feeding set points were handled automatically, pumping the feedstock into the 150 l reactor system.

**Stage 3.** This stage saw an increase in digestion temperature from the basic thermophilic condition (51°C) to 59 °C, while maintaining the doubled organic loading rate. By making these two drastic changes in the fermentation conditions it is well-known that VFA concentrations will be significantly changed (Nielsen, B.H., 2005).

**Stage 4.** Here a return to standard fermentation conditions was ordained, back to identical conditions as in the beginning of the trial. During this stage no organic loading occurred due to stabilizing the process. The table 1 shows a detailed overview of the four stages.

Stage	Conditions	Operational conditions
1	Standard organic loading rate	Loading rate: 10 kg slurry/day Temperature: 51 °C
2	Double organic loading rate	Loading rate: 20 kg slurry/day Temperature: 51 °C
3	Temperature increase	Loading rate: 20 kg slurry/day Temperature: 59 °C
4	Stabilizing period	Loading rate: No organic load.

**Table 1. Treatment stages during the 4 week trial period.**

Each day in the 4 week trial period had its routines of NIR measurements. 6 samples and NIR measurements were conducted during each working day, starting at 09.00 in the morning ending at 14.00 o'clock in the afternoon. Reference samples were analyzed in the control laboratory at Bygholm: Parameters include TS/VS and total-VFA and individual fatty acids according to standard biotechnological measuring methods by GC and TS/VS sop's. Every second sample was set aside to be collected for as a test set.

### On-line NIR measurement loop

The TENIRS measurement equipment is fully described in (Holm-Nielsen et al. 2007) and references herein. It includes a flow-through NIR measuring cell, integrated with the fermentor in a closed loop configuration, Fig. 2.. Fig. 2 illustrates how and where the equipment is placed in the loop and linked to the fermentor. The outlet from the reactor is located midheight on the sidewall of the reactor, mounted with an outlet valve, V1. The loop inlet back into the fermentor was placed in the top of the reactor, but piped to the bottom by an internal pipe, for steering purposes. V2 is a valve with regulation positions allowing to flush the TENIRS with clean water each morning before starting the on-line flow measurements, which also includes white plate reference NIR measurement in the flow cell before operational NIR scanning.

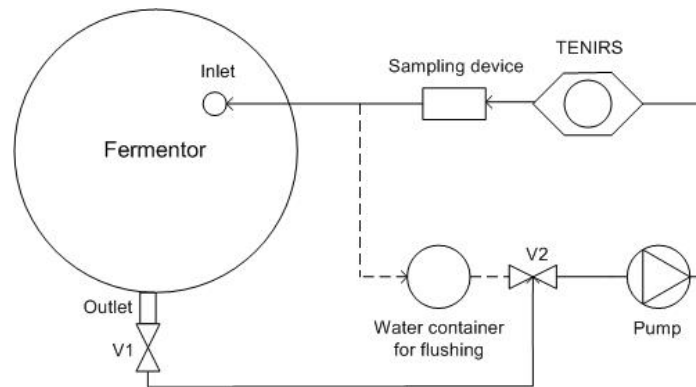

**Figure 2. The TENIRS systems implemented on a loop attachment to the 150 l fermentor.**

The flow-through cell is continuously measuring the NIR specters during the daily measuring periods of approx. 6 hours. Immediately after this flow cell, a prototype of a sampling point was installed. This has a sliding door mechanism coupled to a 10 ml plastic sample container, which was used for incremental sampling (composite sampling) of the continuously flowing matter. After the sampling point the bioslurry returns to the reactor. In fig. 3 is shown a photo of the on-line NIR measurement loop.

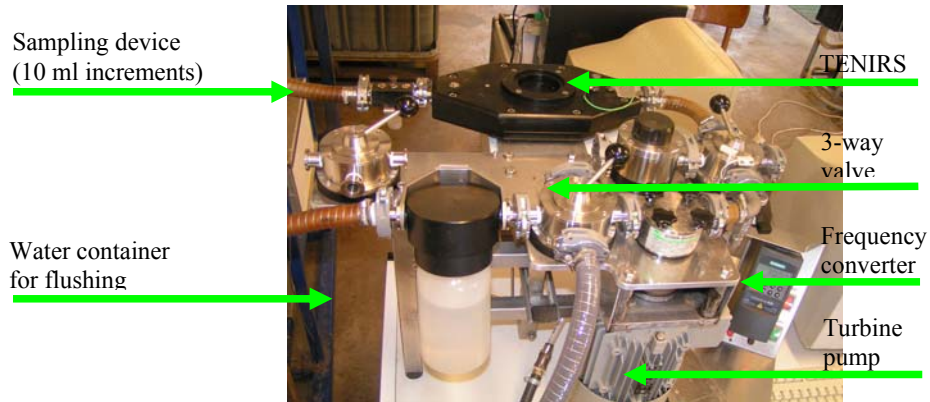
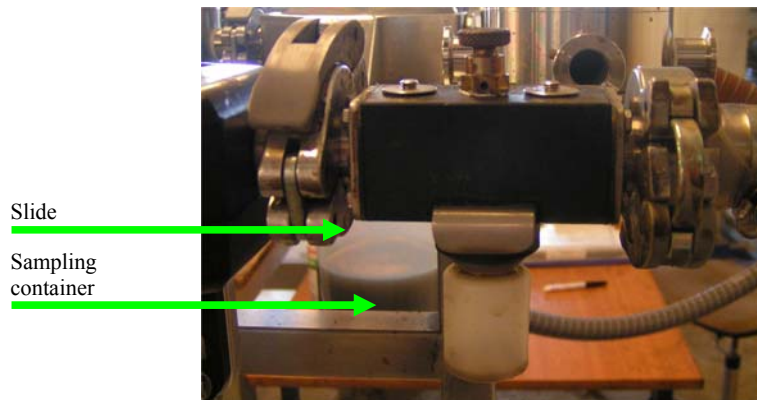

**Figure 3. Physical realization of the TENIRS NIR measurement loop.**

### **Sampling and mixing scenario - Bygholm trials**

Steering of the experimental reactor was realized by recycling gas bubbles a few minutes per hour, as well as by continuous pumping of the bioslurry through the loop back to the bottom of the reactor, recycling it to the fermentor during every 6-hour measuring campaign each day.

Figure 4 shows the sampling station, with sliding door opening and 10 ml sample container. Recurrent loop pumping was initiated half an hour before the NIR-and-sampling operations took place in the morning and then continuously pumping during the 6 hours measuring time frame.



**Figure 4. Primary sampling device, 10 mL container, integrated in the TENIRS recurrent loop.**

Fig. 5 shows diagrammatically the step-wise approach used for representative composite sampling and mass reduction. A is the primary sampling, at the sampling location illustrated in Fig. 4. Sampling takes place immediately downstream the NIR flow-through-cell. The primary sampling is realized as 10 increments, sampled immediately after 60 second NIR scan averaging. 10 increments make up a primary sample of 100 mL.

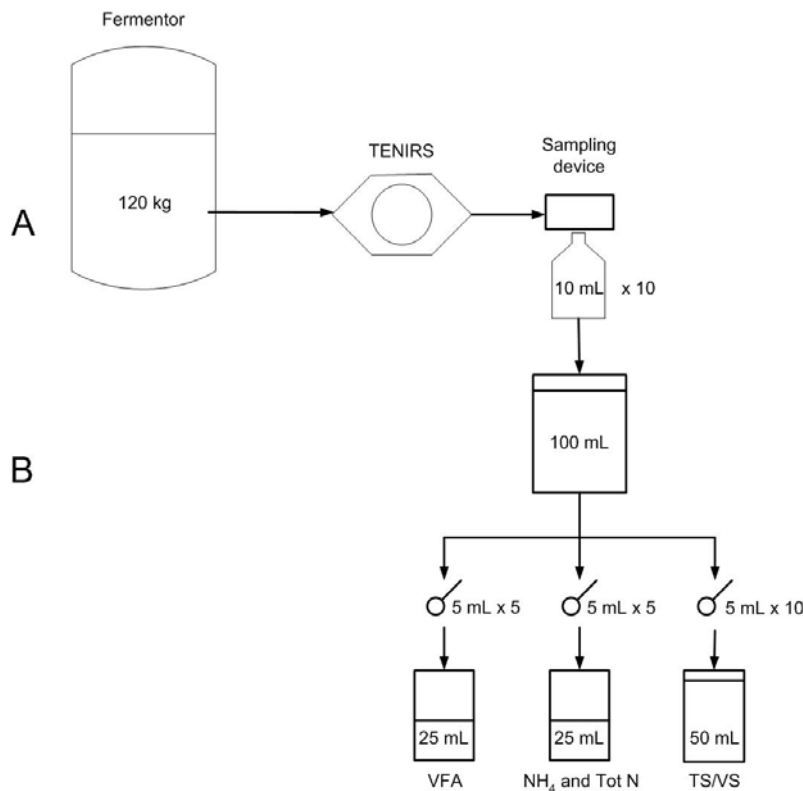

**Fig. 5. Diagram of sampling and mass reduction. A = primary sampling, B = secondary sampling; mass reduction.**

Figure 5 shows the secondary sampling stage B. Two laboratory bottles, each containing 25 mL, were prepared for chemical analysis of total VFA's, ammonium-N and total-N. A third bottle contains 50 mL for TS/VS measurements. Mass reduction is carried out immediately after the primary sampling to avoid evaporation or accidental spillage during handling. All sampling procedures integrated in the study follows guidelines explained in (Esbensen et al. 2006, Petersen et al., 2005, Holm-Nielsen et al. 2006)

### Chemical reference analysis

The purpose of differential loading in this trial was to secure as large variations in the chemical compositions as possible of the important process intermediates, volatile fatty acids (VFA). In Table 2 the resultant span of the total and individual volatile fatty acids is displayed. Total VFA ranged from 1.084 mg/l to a maximum level reaching 11.112 mg/l, which was highly satisfactory in this meso-scale context, but too high a concentration for full scale biogas plants.

Analytical parameter	Minimum concentration	Maximum concentration
Total VFA	1084 mg/L	11.112 mg/L

Acetat		595 mg/L	6761 mg/L
Propionat		399 mg/L	2851 mg/L
i-butyrat		68 mg/L	460 mg/L
Butyrat		12 mg/L	295 mg/L
Methylbutyrat i-valerat	+	25 mg/L	675 mg/L
Valerat		8,4 mg/L	78 mg/L

**Table 2. Lowest and highest VFA concentrations in Bygholm trials.**

Monitoring of the biogas production during the entire spiking trials at Bygholm shows a dramatic decrease in biogas production after the concentration level of total VFA exceeds 4000-5000 mg/l, Fig. 6. On-line PAT monitoring of VFA must be able to detect and quantify these interrelationships accurately and with sufficient precision.

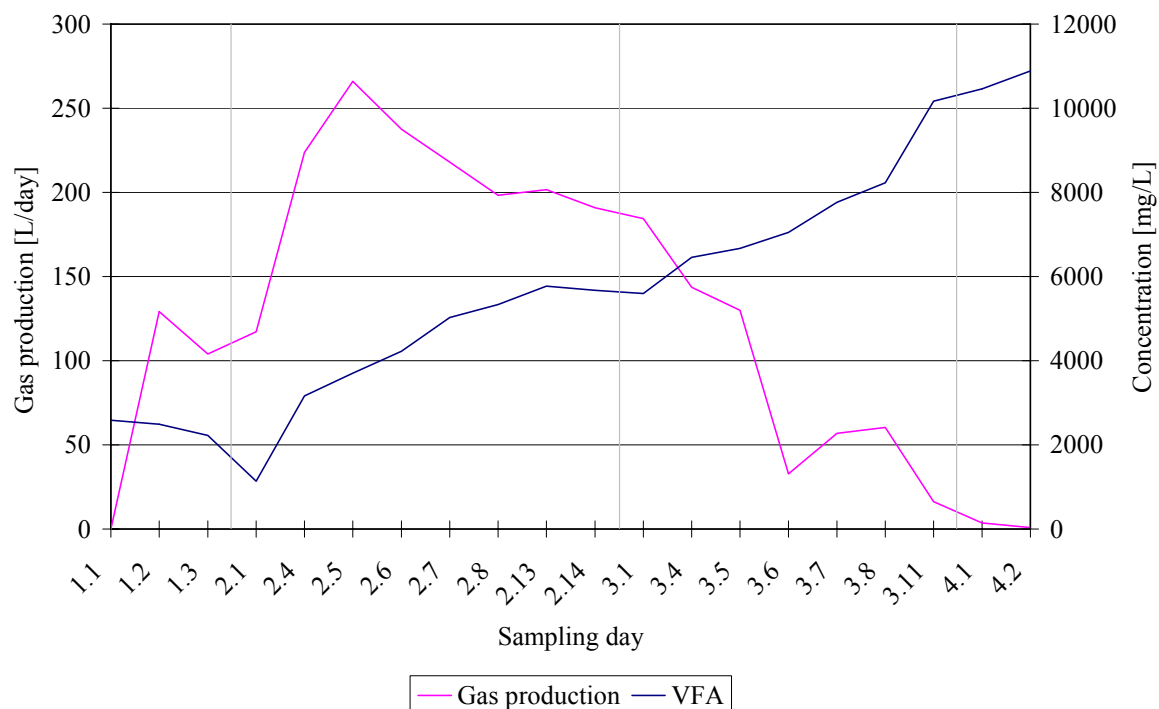

**Fig. 6:** The relationship between VFA concentrations and biogas production for the entire spiking campaign.

### Multivariate calibration and validation issues

Multivariate data analysis makes it possible to process optical signals and other sensor signals for on-line monitoring and control of biological processes. Multivariate calibration data sets are characterized by both sensor signals (X-variables) and chemical lab measured concentration measurements (Y-variables), originating from the



analytical reference measurements by use of GC, AAS, ICP or other central laboratory techniques.

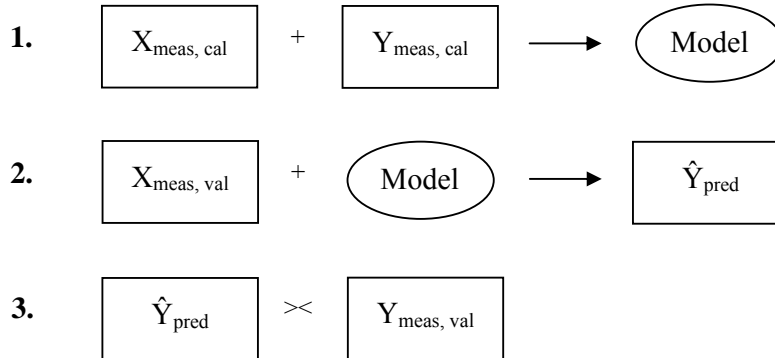

**Figure 7. Development steps of a multivariate calibration model. - A typical multivariate calibration modus in 3 steps. Steps 2 and 3 are used depending on the specific purpose of modeling and/or prediction.**

**Step 1:** A chemometric regression model is developed from the X- and Y- variables.

**Step 2:** This developed model is to be used to predict new Y-variables, directly from the sensor signals X-variables. Before use of this prediction facility, the model must be thoroughly validated.

**Step 3:** Validation of model performance. The predicted values (Y-pred) are compared to appropriate reference values for the same objects as measured analytical results. Hereby a valid measure of the strength of the model for *future* predictions will be established.

In general the smallest differences between predicted and reference values, over the entire validation data set, constitute the better model. It is both possible that the validation meets/does not meet the necessary performance criteria (see further below).

### **Multivariate data modeling**

In the case of large number of variables relative to the number of observations or objects, data compression (projection) by expressing the original x-variables by fewer latent variables or factors is necessary. Partial Least Squares regression (PLS) does this calculation - and simultaneous optimization of the "optimal" number of factors for maximum explanation of variance in the y-variables is achieved by validation. The model contains all the necessary parameters needed for prediction of y for new values of the x-variables. The PLS model which relates the X-data to the Y-data is given by the two expressions below:

$$(1) \quad X = TP^T + E$$

$$(2) \quad Y = UQ^T + F$$

**T** and **U** are component scores, **P** and **Q** are x and y-variables loadings and **E** and **F** are the residuals in **X** and **Y**, respectively. Alternatively, Eq. (1) could be expressed in the form:

$$(3) \quad X = t_1 p_1^T + t_2 p_2^T + \dots + t_k p_k^T + \dots + t_l p_l^T + E$$

$l$  is equal to maximum number of latent variables for maximum explanation of variance in **Y**. If there is only one y-variable to be modeled Eq. (2) can be replaced by the following equations (termed PLS1 regression):

$$(4) \quad y = Tq^t + F$$

In this case the regression coefficients to be used in the predictor  $y = \mathbf{1}b_0 + \mathbf{X}\mathbf{b}$  are computed as follows:

$$(5) \ \& \ (6) \quad \hat{\mathbf{b}} = \hat{W}(\hat{P}^T W)^{-1} \hat{q}$$

and

$$b_0 = \bar{y} - \bar{x}^T \hat{\mathbf{b}}$$

where  $W$  are so-called *loading weights* in PLS1. These are the operative model parameters, which express the essential X-Y inter-relationships (further technical details can be found in Esbensen (2001), Martens & Naes (1996).

By scaling the variables, domination of variables with large, dominating standard deviations -  $s(x)$  on the model, can be avoided. The weighting of  $x_{i,k}$  by centering and scaling, called *auto-scaling*, is performed according to:

$$(7) \quad x_{ik,w} = \frac{x_{ik} - \bar{x}_k}{s(x_k)}$$

The type of validation applied in this work is either test set or cross validation. Validation determines the optimal number of PLS-components or latent variables that give the lowest prediction error for future objects /measurements.

In the Linkogas trial the calibration set was split into  $s$  segments, which means that the validation is carried out  $s$  times, each time with  $1/s$  of the objects left out of the modeling and used only for prediction validation. This cross validated residual variance in  $y$  after inclusion of  $l$ .th latent variables is as follows:

$$(8) \quad \text{Var}(y)_{\text{val},n} = \frac{1}{I_{\text{pr}}} \sum_{i=1}^{I_{\text{pr}}} (\hat{y} - y_i)^2$$

Where  $I_{\text{pr}}$  is equal to the number of validation objects, which is equal to the number of the calibration objects.  $y_{i\text{-pred}}$  is the predicted value and  $y_i$  the corresponding reference value.

Quality criteria, which describe the prediction validation, are the root mean square error of prediction (RMSEP), the bias and the standard error of prediction. The parameters are calculated by the following formulas:

$$(9) \quad \text{RMSEP} = \sqrt{\text{Var}(y)_{\text{val},n}}$$

$$(10) \quad \text{Bias} = \frac{1}{I_{\text{pr}}} \sum_{i=1}^{I_{\text{pr}}} (\hat{y} - y_i)$$

$$(11) \quad \text{SEP}^2 \approx \text{RMSEP}^2 - \text{Bias}^2$$

We here rely on RMSEP.

For validation in this work, it was decided to make provisions for a proper test-set validation for the Bygholm trials. Every second sample of the total of 112 was selected to make up a *test set* (Esbensen, 2001). The LinkoGas trials made use of cross-validation.

The iterative algorithms for calibration, validation and prediction are described in detail in Martens & Naes (1996) and Esbensen (2001). The software applied for PLS was UNSCRAMBLER, ver. 9.7.

### **Data pre-treatment**

NIR spectra from two-phase systems, especially solid-liquid systems, bioslurries included, are very often in need of scattering compensation.. Multiplicative Scatter

Correction (MSC) was applied as a well-tested such pre-treatment approach. Of a total of eight analytical reference parameters, the biotechnologically most important were total VFA, acetic-acid and propionic-acid, for which full multivariate calibration/validation analysis will be reported.

Esbensen (2001) details a layout for full documentation of a multivariate calibration model with appropriate validation. Below this design will be followed in presenting and assessing the three Bygholm models developed. The *explained calibration variance* plot

– and the *residual validation variance* plot are used to delineate the %-modeling of the X-data and Y-data respectively. These plots allow to decide on the important “optimal number of PLS-components”. The complementary loading-weight plot shows the operative contributions from the wavelength regions involved (usually displayed for the most influential components only). The so-called “predicted vs. measured” plot is better named the *predicted vs. reference values* plot; this plot in essence captures the prediction performance of the model, based on the optimal number of components. Two statistics are used for this evaluation, based on a *fitted* regression line to the predicted/reference data, **i**) the slope: a measure of the average accuracy of the predictions, which should be as close to 1.0 as possible; **ii**) the correlation ( $r^2$ ), which should likewise be as close to 1.0. This latter index is a measure of the precision of the prediction; again an average statistic representing the entire test set compositional range.

### Bygholm model of total VFA

The plots in Fig. 8. are based on MSC pretreatment . 8 outliers were removed, leaving 104 sample, of which 53 made up the training set and 51 samples the test-set. Four PLS-components were found optimal (arrows in left-hand side of Fig. 8.)

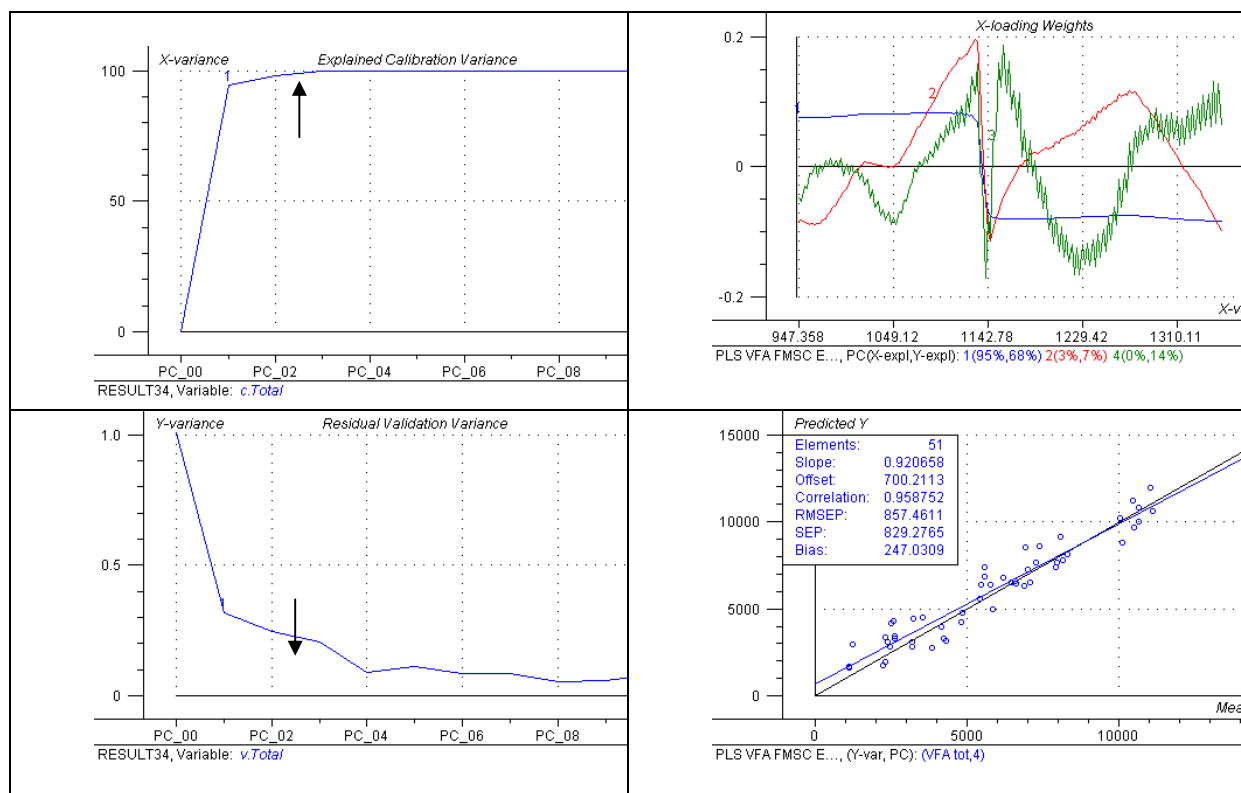

**Figure 8. Full documentation of PLS-model for VFA, using MSC and test set validation.**

In Fig. 8 it can be seen that 95% of the explained calibration X-variance can be described by the first PLS-component and that 100% of X-variance is reached for four PLS components. More importantly, four PLS-components manage to model 92% of the Y-variance, signifying a very high degree of modeling total VFA from the NIR

spectra. The loading-weights plot illustrates PLS-components 1, 2 and 4. The fitted regression line of the “predicted versus measured” plot (predicted vs. reference) shows good statistics for the slope (0,92) and correlation ( $r^2$ ) =0.92. Both values are highly acceptable for this complex system. A 45-degree diagonal is integrated in this plot, allowing for direct visual inspection of how well predictions follow the reference levels.

### Bygholm model of acetic acid

The acetic acid plots is illustrated in fig 9. Full MSC pretreatment methods and test set validation has been used. 9 outliers were removed, 103 reference samples were used, 52 for the training-set and 51 samples for the test-set. For the final model 4 PLS components were found to be optimal.

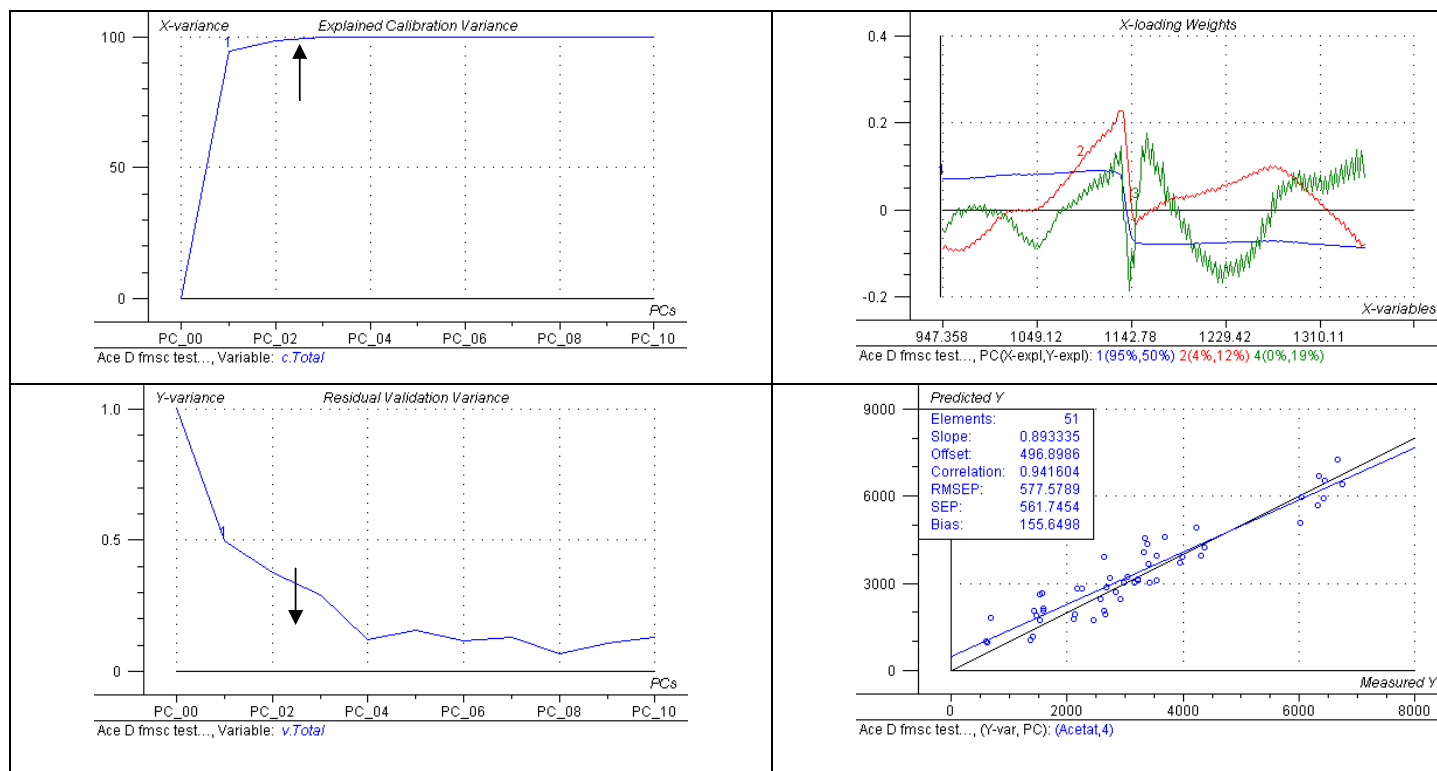
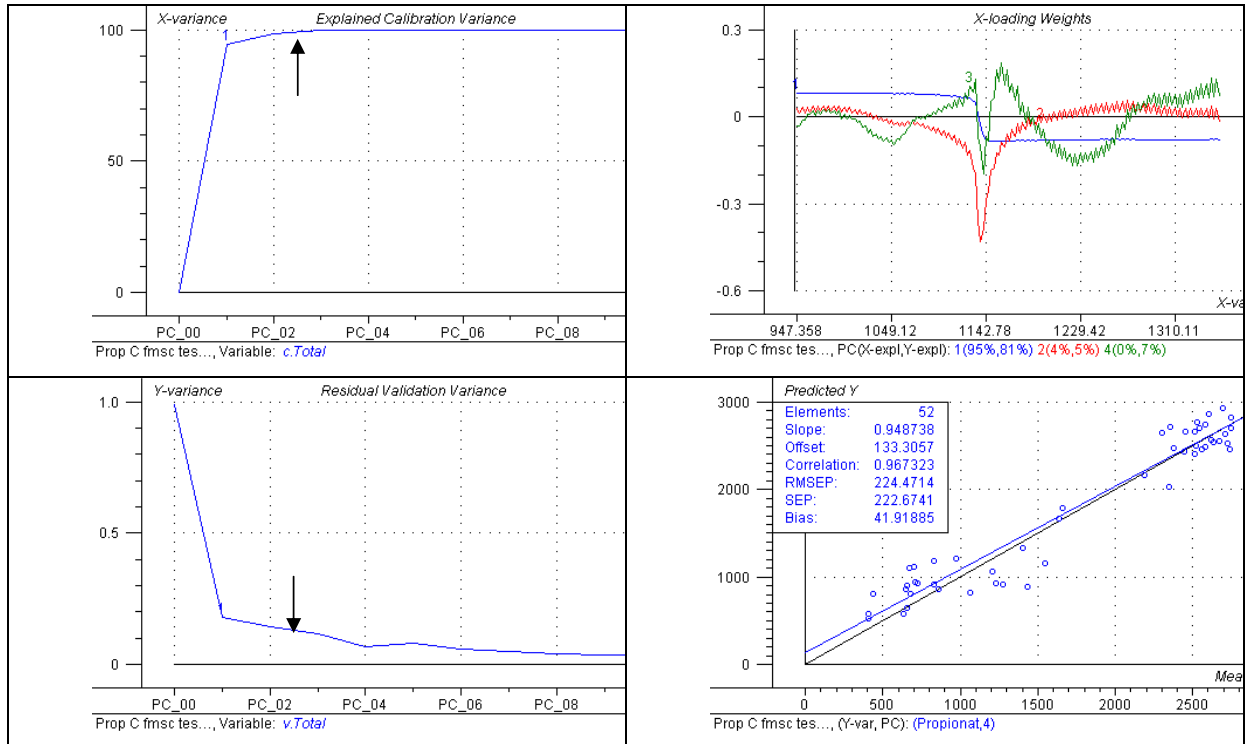

**Figure 9. Plots of the PLS model for acetic acid, using MSC and test set validation.**

In Fig. 9 it can be seen that 95% of the explained X-variance can be described by the first PLS-component and 100% of the X-variance by 4 PLS components. The regression line of predicted versus measured shows good statistic values of a slope at 0,89 and  $r^2$  at 0,89. Four PLS-components managed to model 89% of the Y-variance, signifying a good degree of modeling for acetic acid from the NIR spectra's. Prediction versus measured (reference values) shows that for acetic acid the prediction follows the reference values at an acceptable level.

### Bygholm model of propionic acid.

Plots of propionic acid models are illustrated in fig. 10. From data treatment 8 outliers had to be removed, 104 reference samples were used, 52 in the training set and 52 samples for the test set. For the final model four PLS components was found optimal to explain the calibration variance. Compared with models of VFA and acetic acid models, the first PLS component for propionic acid explained most of the total Y-variance in this model.



**Figure 10.** Plots of the model for propionic acid, made by FMSC and test set validation.

The loading weights plot illustrates PLS-component 1, 2 and 4. The fitted regression line of predicted versus reference values shows high statistic values for the slope at 0,95 and correlation  $r^2$  at 0,94. Both values are highly acceptable for this heterogenous system. As in earlier studies (Holm-Nielsen et al. 2007) it is noticed that VFA and acetic acid modeling has similar approaches, and that propionic acids has better slope and correlation.

Reference parameter s	Slope	r <sup>2</sup>	Outliers	PLS-components
Total VFA	0,921	0,919	8	4
Acetat	0,893	0,887	9	4
Propionat	0,949	0,936	8	4
i-butyrat	0,921	0,904	5	2
Butyrat	0,926	0,933	(6) 7	4
Meth.but + i-valerat	0,932	0,950	(6) 5	4
Valerat	0,892	0,920	(18) 6	4

**Table 3. Test set validation results for all Bygholm calibration models. All models were pretreated by MSC.**

Table 3 gives complete calibration/validation details for all volatile fatty acids models in the Bygholm studies. The experimental work resulted in good PLS-prediction models for total VFA, and all individual volatile fatty acids. The average slope-values for all volatile fatty acids were 0.92 and the correlation  $r^2$  were 0.92. From table 3 it can be appreciated that four PLS components managed to model 92% of the Y-variance, indicating a high degree of modeling all VFA acids from the NIR spectra. Furthermore it was noticed in Fig. 6 that VFA contents had a significant correlation with the biogas production, emphasizing the importance of VFA as a key process intermediate indicator during the anaerobic digestion processes for biogas production management purposes.

### **Case 2: Full-scale 2400 m<sup>3</sup> LinkoGas centralised biogas plant – On-line PAT monitoring studies.**

This biogas plant is owned by an independent farmers co-operative with 66 members. Built in 1989-90 by Bigadan Ltd., Denmark and reconfigured in 1999 by BioScan Ltd., Denmark. It was converted from mesophilic to thermophilic operating conditions. A post-digestion unit was also established at the latter date. These augmentations resulted in a 50 % increase in gas production. LinkoGas is one of the largest centralised co-digestion biogas plants in Denmark, indeed in the world. In 2008 Linkogas undergoes a further upgrading of its production capacities.

The plant receives liquid- and solid manure composing of 53 w-% cattle and 47 w-% pig slurry, with a minor additional part as solid manure. The slurry is supplemented with easily digestible organic waste from fish- and food processing industries, organic

by-products from pharmaceutical industries, intestinal content from abattoirs, and pressure sterilised catering waste. The latter organic by-products constitute good sources of organic oil and fat concentrated feedstocks. LinkoGas has steadily been able to increase biogas production considerably compared to the original design. The annual report from 2006 states that the biogas yield has raised to 7.3 mill. Nm<sup>3</sup> yr<sup>-1</sup>, compared to 5.7 mill. Nm<sup>3</sup> yr<sup>-1</sup>, 2005, due to technical/biological improvements, see figure 11.

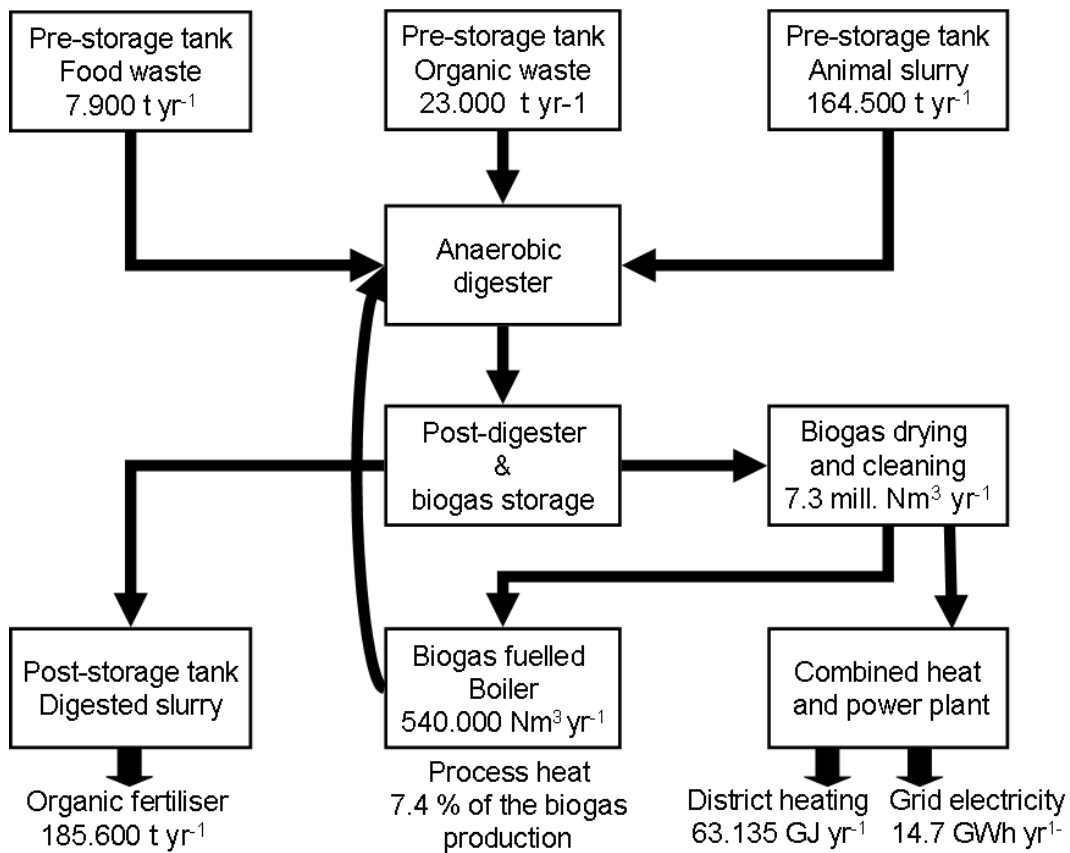

Figure 11. Biomass flow diagram and infrastructure at the centralised biogas plant LinkoGas A.m.b.A. Year of flow 2006.

Recently however, use of biofuels and biodiesel based oil has started growing markedly due to an increasing world marked demand for alternatives to fossil fuels. In order to meet this demand, and also to boost the biogas yield still further, the use of energy crops or other concentrated feedstock such as glycerol or wet distiller's grain and solubles (WDGS) is in progress internationally of being introduced in the biogas sector.

With a continually changing feedstock and biomass bases, and also for production optimisation, process imbalances and indicative process parameters should be closely monitored and controlled on-line and in real-time. Particularly, the effect of organic overloading can severe disturb the biogas process and in a few recorded cases has completely inhibited the process. Only effective use of reliable on-line monitoring- and control systems can guarantee stability and safety of these continuous processing



systems. A significant increase in biogas yield can be realised by increasing the organic load, provided that the biogas process is kept within safe limits w.r.t. VFA and ammonium concentrations.

The infrastructure at LinkoGas consists of pre-storage tanks, biogas reactors, and post-storage tanks for digested slurry to be applied as organic fertilizer in the crop growing season. The latter are located both centrally at the plant and decentralised in the fields at the cooperating farmers. Among other technical installations are pumps, heat exchangers, biomass macerating equipment, boiler heating system for supplementary fermenter and bioslurry heating, biological biogas cleaning facilities, biogas cleaning and air-cleaning systems.

#### **Experimental plan - LinkoGas spiking trials**

The experimental plan consisted of two months on-line full-scale spiking trials at LinkoGas. First industrial glycerol from the biodiesel industry was to be introduced in order to determine the effect of VFA concentrations while simultaneously boosting the biogas production. A follow-up made use of pre-sterilized catering waste as an adjustable feedstock was tested out as well.

<b>Period</b>	<b>Samples</b>	<b>Glycerol [ t d<sup>-1</sup> ]</b>	<b>Food waste [ t d<sup>-1</sup> ]</b>
0	1-12	0,00	4,00
1	13-29	0,96	4,00
2	30-45	2,40	3,00
3	46-65	3,84	3,00
4	66-75	1,68	3,00
5	76-78	3,60	3,00
6	79-81	5,04	5,00
7	82-83	3,60	4,00
8	84-101	4,80	5,00

Table. 4: Initial experimental spiking plan at LinkoGas

#### **Linkogas implementation of Process Analytical Technologies (PAT)**

It was decided to implement a *recurrent loop* on fermentor No. 3 (2400 m<sup>3</sup>) at Linkogas, see Fig. 12. The sampling strategy was developed in accordance with the Theory of Sampling (TOS), i.e. increments were extracted at the same time as bioslurry was scanned by the NIR instrument in the upward flowing segment of the loop, yielding representative composite reference samples. Ongoing studies are carried out to test and develop PAT applications in the biogas sector, making good use of experience gained in various other sectors like the food- and pharma sectors.

Integration of advanced sensor technology, multivariate data analysis and representative sampling in industrial applications, with the aim of optimising product quality and process performance, has been well described in literature. Process Analytical Technology (PAT) is the term used to describe the powerful synergy that exists between

these three disciplines. See for instance Bakeev (2005) and Junker & Wang (2006) for concrete examples on the many implementations reported in various industries.

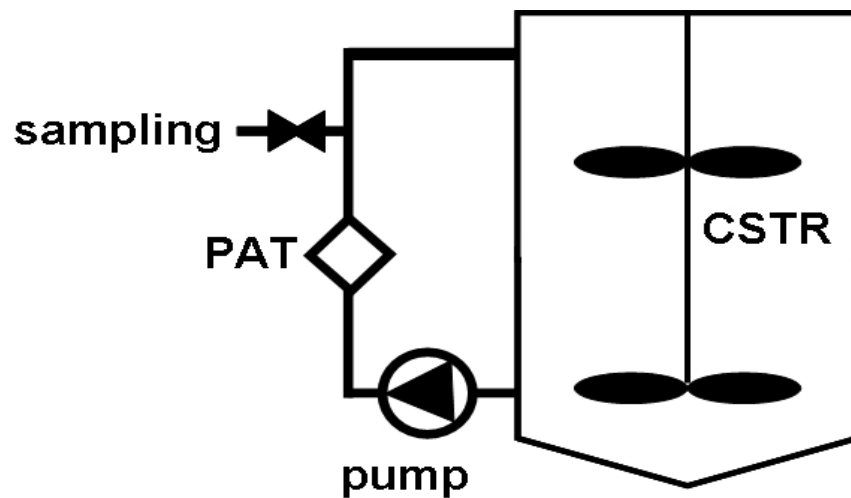

Figure 12. Process Analytical Technology re-current pump loop installed on a reactor vessel in accordance with the Theory of Sampling. Adapted in modified form from [Holm-Nielsen et. al. 2007b].

The pharmaceutical sectors, together with food processing industries have been frontrunners in the development and implementation of PAT tools. Hence, the vast majority of available references concern these two sectors. However PAT principles are universal and can be applied to any other sector as well, e.g. also new growing sectors like the renewable energy sectors. It is the objective of full-scale biogas studies, just started with the present work, to demonstrate that PAT principles can be adapted in the biogas sector, indeed to the whole of the biorefinery sector as well.

#### **Critical success factors:**

For full-scale reactors with significant variations in feedstock composition, operation managers and technicians rely heavily on past experience in controlling a few selected process parameters believed to carry optimal information, such as temperature, gas yield and gas quality. If the temperature is decreasing in the reactor it will influence the working conditions of the microbial consortia immediately, and the biogas production will drop rapidly. Extracted samples for *calibration* of monitoring models have to reflect all essential variation in concentration levels in order for the models to be reliable and suitable for prediction of *future* values of the process parameters.

Calibration manipulation of volatile fatty acid concentration can be accomplished by increasing the amount of glycerol and pressure-sterilised food waste added to the reactor as described below. It is therefore essential that the amounts of these two feedstock can be measured and injected completely as desired, according to an experimental plan (experimental design). In future this will be handled by on-line, automatically adjustable controllers.

Effective communication is another important factor between project officials and plant technicians. Comprehensive records of events and actions must be kept. By doing this,

alterations and variations in the feeding strategy, temperature, amount of glycerol added, and other disturbances will be noticed on time before they cause severe harm to the plant. During this full-scale trial the authors have faced such difficulties but they have largely been overcome.

## Linkogas trials. Materials and methods

### *Sampling*

The sampling strategy applied in this study was further developments of primary representative composite sampling (Holm-Nielsen et al. (2007) and Esbensen et al. (2007)). Procedures for representative mass reductions follow the same routes as for the Bygholm study above. Investigations of how to minimize the errors and how to make use of automatic sampling devices have been successful. For in-depth knowledge of the power of Theory of Sampling (TOS) see [Esbensen et al. (2005), Gy (1998), Pitard (1993), Petersen et al (2004), Petersen et al (2005a), Petersen et al (2005b)]

### *Near infrared spectroscopy*

A reflection probe with an effective detection area of 1 mm<sup>2</sup> was installed in the recurrent loop and NIR-spectra were acquired using a Bomem MB160 FT-NIR spectrometer (Hartmann & Braun, Quebec, Canada) equipped with an InGaAs detector. The wavelength interval is 1111 – 2222 nm, with a resolution of 8 cm<sup>-1</sup>, yielding 1167 data points (X-variables). A Spectralon<sup>®</sup> disc was used for calibration reference spectra. Calibration spectra were based on 128 scans, while 100 scans were averaged for all sample spectra.

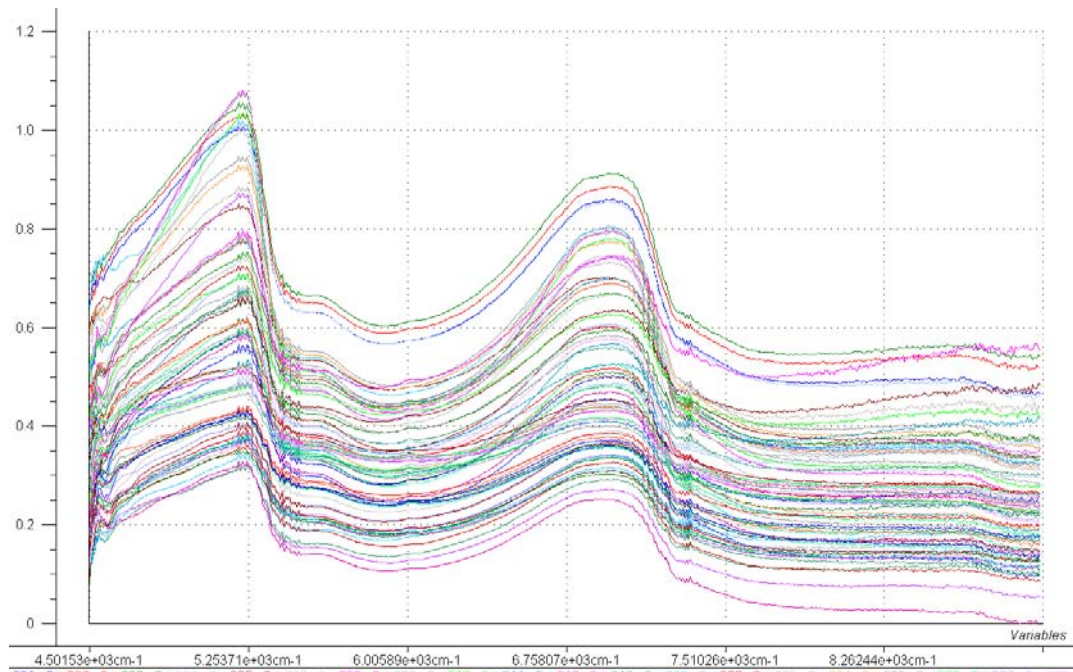

Figure 13. Original near infrared absorbance spectra for all samples in the LinkoGas study.

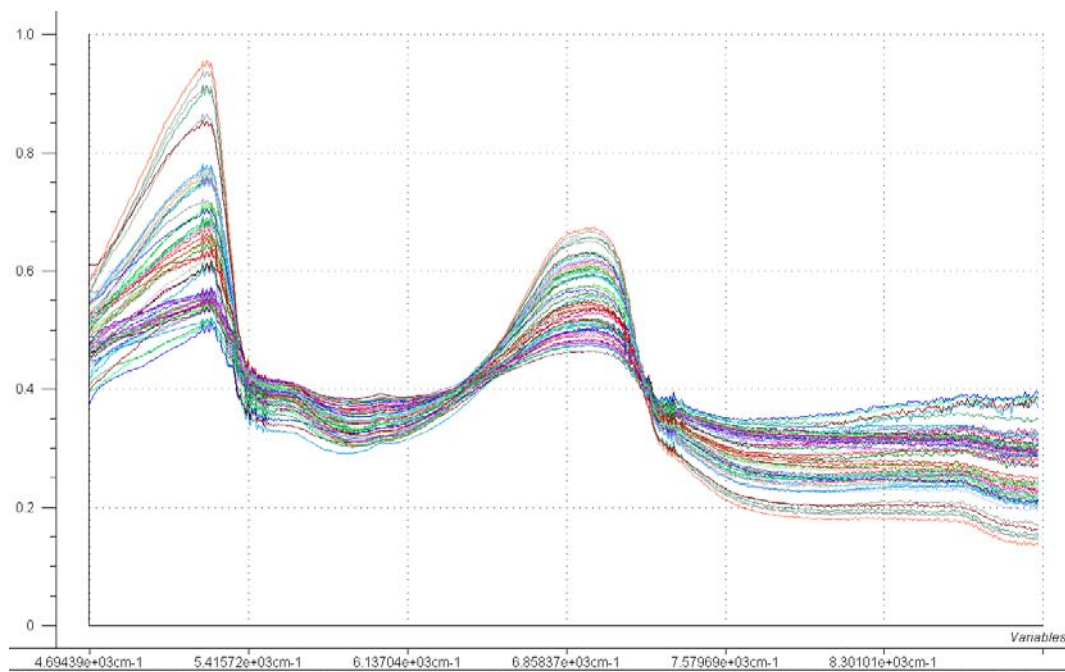

Figure 14. LinkoGas NIRa pre-treated using  $\alpha$ -MSC (common offset) after removal of significant outliers.

#### *Chemical analysis of volatile fatty acid*

Chemical reference analysis was performed for volatile fatty acids: acetic acid, propionic acid, butyric acids, valeric acids as well as the sum-total, total VFA. All these parameters were modelled using PLS-1 multivariate calibration. The NIR spectra were  $\alpha$ -MSC pre-treated in order to remove scatter effects from suspended particles and fibres. (Esbensen, 2001)

Sample aliquots with volumes of 1.0 ml were mixed with 1.0 demineralised water and 2.0 ml internal standard. Samples were centrifuged at 3000 g for 10 minutes in a Medifuge (Heraeus Christ GmbH, Osterode, Germany). The supernatant was withdrawn and filtered through a 0.45  $\mu\text{m}$  acetate filter directly into a GC-vial. Samples were analysed immediately on a gas chromatograph model Varian3800 (Hewlett Packard) equipped with a Flame Ionisation Detector.

#### *Volatile fatty acids content*

An overview of the full range of VFA reference analysis is given in the below table including analytical errors.

[mg L <sup>-1</sup> ]	Min. Concentration	Max. Concentration
Total VFA	57 $\pm$ 2	3033 $\pm$ 213
Acetic acid	57 $\pm$ 2	2558 $\pm$ 185
Propionicacid	7 $\pm$ 1	573 $\pm$ 3
Butane	36 $\pm$ 3	124 $\pm$ 4
Isovaleric	2 $\pm$ n.d.	53 $\pm$ 1
Valeric	32 $\pm$ n.d.	58 $\pm$ n.d.

Table 5. Min. and max. concentration levels of VFA and analytical error of the individual fatty acids.

The main acids detected at the LinkoGas plant were acetic acid and propionic acid. In a few samples other acids were also found, but with concentration levels close to the detection limit of the gas chromatograph; these were never the less incorporated in the total VFA concentration.

**Linkogas Multivariate data analysis:**

The multivariate calibration is based on both sensor signals (X-variables) and reference measurements (Y-variables). For details see *Case I* – Bygholm regarding multivariate data analysis.

Gross outliers were detected and removed from the data material by first using Principal Component Analysis (PCA). Noisy areas in the spectra were also removed. Also here Multiplicative Scattering Correction (MSC) was performed to remove scatter effects. Segmented cross-validation was chosen as validation method due to the lower numbers of samples and the low concentration level of VFA's. The data in this case study was in the very low range of concentrations. The best validation methods is without doubt test set validation, which will be the validation methods to be applied when spiking facilities are in place in further studies at Linkogas [Esbensen 2001].

The LinkoGas multivariate data analysis altogether is comprised of a low number of samples for the final analysis. In a system as complex as the present, with very low analytical concentration levels, it is unfortunately not possible to divide such a data set into two data sets, comprising of a training set and a test set.. Reluctantly the cross-validation must them be used, with full reference to the accompanying scientific reservations as described in Esbensen (2001).

The global minimum of the root mean square error of prediction-statistic, RMSEP, was used as criterion for choosing the optimal number of PLS-components in each model. RMSEP is calculated as follows:

$$\text{RMSEP} = \sqrt{\frac{\sum (y_{\text{predicted}} - y_{\text{reference}})^2}{n}},$$

n is the number of samples used for the validation.

Multivariate data analysis was performed using the software The UNSCRAMBLER v. 9.7 (CAMO Process ASA, Oslo, Norway). All plots of results from the multivariate modelling were produced using The UNSCRAMBLER. A brief description on PLS-prediction model validation and assessment was given above for *Case I* – Bygholm, which applies here as well.

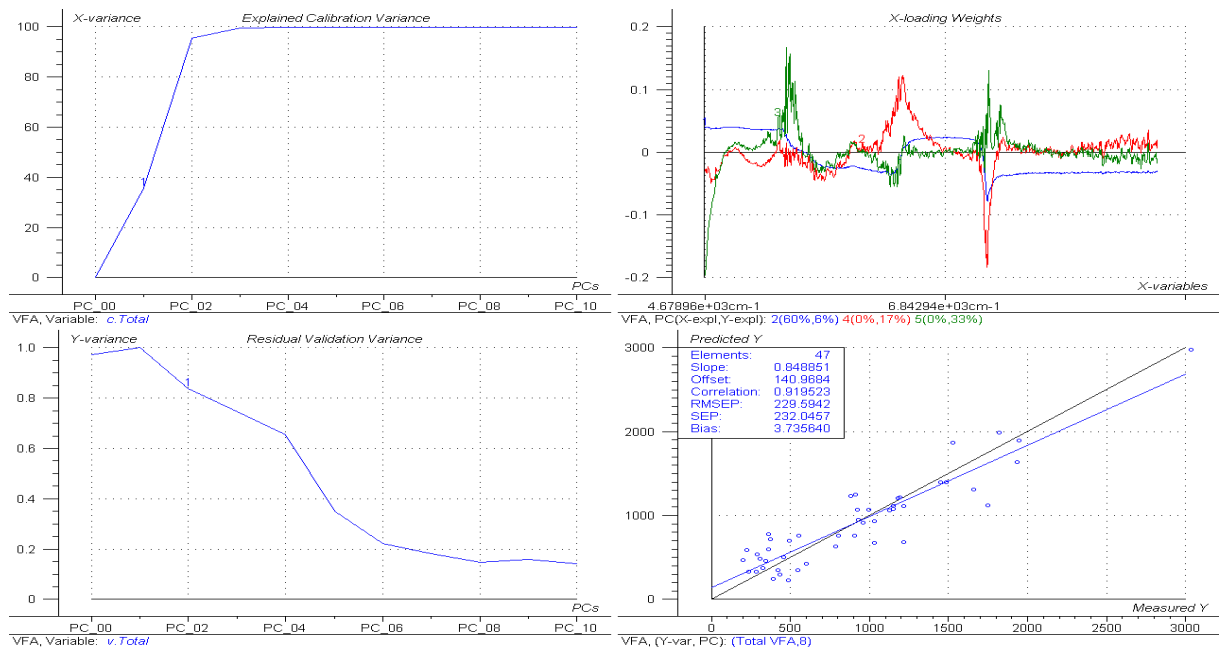

Figure 15. Documentation of PLS-model for VFA, using MSC and full cross validation. N = 47 objects.

In Fig. 15 it can be seen that 95% of the explained calibration X-variance can be described by the two first PLS-components, and 100% can be described by four PLS components. But eight PLS-components had to be used to model 84% of the Y-variance, signalling a very complex model of total-VFA. The loading weights plot are made for PLS-components 2, 4 and 5, which has the strongest influence on the model. The total VFA concentration levels were from below 200 mg/l to very few between 2000mg- 3000 mg/l. The slope was 0.85 and the correlation  $r^2$  was 0.92. These values are acceptable, indicating good model possibilities, but a wider spanning of concentrations is needed for fully robust models developments. This model gives a clear preview into the on-line monitoring possibilities of VFA concentration levels.

### Unforeseen events during full-scale Linkogas trials

Un-expected events occurred during the project period that should be taken into account when evaluating the models and results. These events are sources of significant errors of unknown extent, especially it made the model of the chemical analyses spanning a smaller interval and at generally lower concentrations than originally planned.

During the first period with the spiking trails, there has been a significant fluctuation in the reactor temperature. The lowest temperature measured inside the reactor between September 30<sup>th</sup> and November 30<sup>th</sup> was 49.1°C, the highest was 52.1°C; average temperature was 50.6°C +/- 0.8°C. This was noticed as the biogas production was continuously decreasing. Measures were set in operation to ensure increase and stabilisation of the reactor temperature by the plant technicians.

The glycerol was a well-known concentrated organic by-product also used elsewhere to boost biogas production, and here at the same time specifically used to provoke the necessary variations in the VFA concentrations. Meanwhile, analysis of the glycerol indicated that it had been diluted with water. This was observed the 8<sup>th</sup> of November when the feeding pipeline of glycerol clogged. On re-opening of the glycerol spiking pipe, pressure sterilised organic waste was used to support the glycerol with varying purity of 2%-5% to increase the level of VFA concentration in the fermentor and thereby increase the gas production. The glycerol was purchased as a by-product from a biodiesel processing plant. The concentration of glycerol can now be seen to be too low to achieve the desired wide span in the process variables in combinations with the explained physical variations. For calibration purposes a concentrated form of glycerol is needed, not by-product glycerol, but in this case, running costs for the full scale biogas plant played an important role. High quality glycerol has increased very significantly in price recently and is simply too costly for biogas plants at present. Nearly all available glycerol currently goes to the pharmaceutical sector, due to decrease or an intermediate pause in the European biodiesel production.

#### *Sampling and NIR scanning errors*

The experimental design and workplan called for extraction of a number of increments from the looping sampling valve during a NIR-scan time of 91 s, obtaining a representative composite sample. Unfortunately local construction of this loop (before the present experiment was initiated) and practical placement of the sampling valve made it difficult in practice to extract the desired number of increments in the relatively short time available. The sampling valve had to be operated manually and there were variations in the consistency with which increments were materialised, thereby violating some of the principles of TOS.

The large diameter of the recurrent loop (150 mm), compared to the 1 mm<sup>2</sup> detector footprint of the NIR-probe certainly caused a large mismatch between the X- and the Y-data, which can be viewed as a severe lack of volume support for the X-signals. The probe was only able to see a very superficial view of the process stream, not helpful for obtaining a representative signal of the stream.

#### *Volatile fatty acid influence on the gas production*

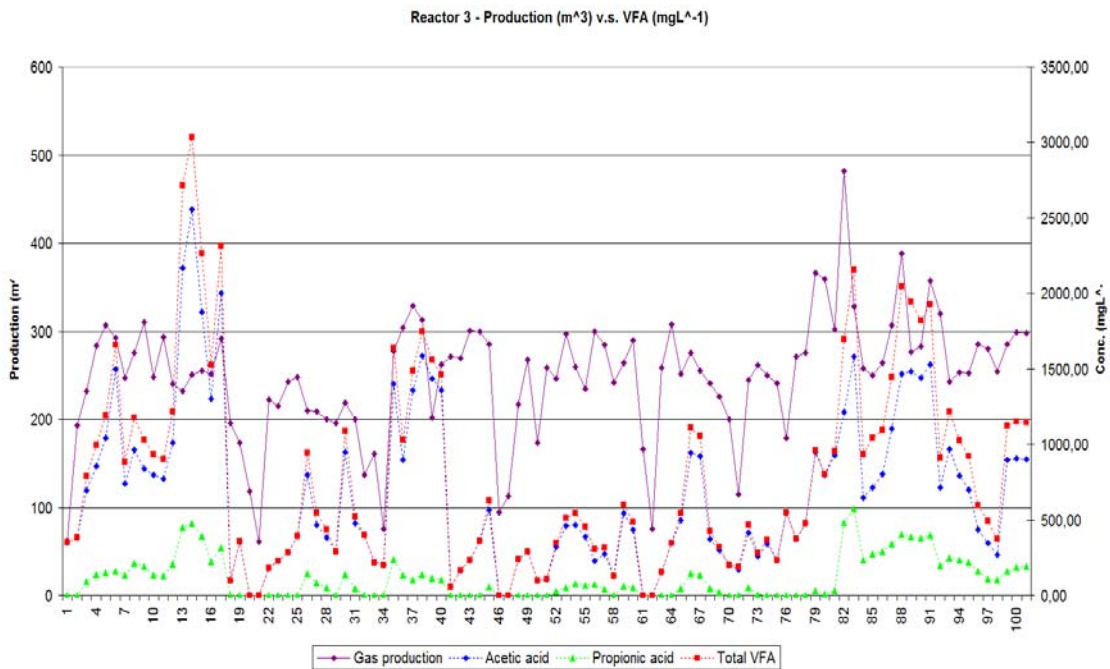

Fig 16 Volatile fatty acids concentration vs. biogas production (Conc. mg/L vs. biogas prod. m<sup>3</sup>)

Figure 16 depicts VFA concentration versus biogas production yields for all samples covering the entire 2-month trial period. In general, when VFA concentration increase, the biogas production increases as well. Samples 20-21, 46-47 and 61-62 were taken during the feeding; therefore a low VFA concentration was as expected, but here extremely low. It cannot be affirmed that the VFA and the accompanying production drop for samples 18-21 were only due to the fed-time, since the boiler also broke down during this period. However, with reference to the daily biogas production, we may likely assume that the temperature drop had no significant influence on the biogas yield, since it stayed rather constant.

It can be seen that, when the glycerol tank surplus was dumped into the common pre-storage tank on October 11<sup>th</sup>, the VFA content increased significantly, samples 11-17. Most important in Fig. 16 is the final increase in VFA concentrations, from sample 76 – 91 in the final testing period of the entire trail. In this period the feeding strategy was under full control of the spiking intentions and in complete management control. After quite a succession of practical full-scale operational problems, it will appear that on-line VFA control and gas production can indeed also be manageable.

### LinkoGas case discussion.

The scope of the second case study was to demonstrate and document feasibility of on-line near infrared monitoring of volatile fatty acids at full-scale anaerobic digestion plants. This perspective is interesting also in a wider context, for real-time, non-invasive monitoring, automated control and regulation in the wider bioconversion realm. The main conclusions for the LinkoGs study are discussed below:



- Addition of glycerol will increase the methane yield. Nevertheless, in order to ensure a stable anaerobic digestion process, the amount of glycerol should not exceed 5-7% of the total volume concentration at thermophilic AD conditions.
- Rather few documentations of full scale anaerobic digestion on-line process monitoring/control/regulation studies exist. The present study adds significantly to this issue.
- The biogas yield is sensitively affected by variation in volatile fatty acid content, as shown by the induced variations in feeding strategy in both case 1 and 2 studies.
- A stable VFA content and controllable level should lead to a more stable biogas production yield. The primary sampling step at the plant still needs to be improved. This can be done with an automated sampling valve.
- LinkoGas biogas plant has natural low volatile fatty acid concentration content due to its specific feedstock composition. This results in special difficulties in reference sampling for multivariate calibration and validation. This points to the need for TOS to be incorporated as a genuine PAT tool. The prediction precision; correlation  $r^2$  was at 0.93 and slope 0.85, are fully acceptable for this type of highly heterogeneous system
- In order to develop a robust regulation tool for AD plants, chemometric modelling facilities should be embedded into an electronically data file system to be used also by other applications for monitoring/control/regulation purposes.
- Further R&D is critically needed in order to develop robust, non-invasive, low cost PAT tools dedicated as a regulation tools for biogas plants worldwide. In this context TOS ranks as a *missing link* in PAT.

#### **Perspectives for on-line Process Analytical Technologies in biogas production - planned future developments.**

The sampling procedure will be further developed in accordance with the Theory of Sampling and made completely automated in order to enable representative samples to be extracted without poorly reproducible manual sampling. In addition, increased reproducibility of the critical mass reduction step is expected to have a significant impact on multivariate models.

The near infrared sensor can with advantage be augmented with other multivariate process analysers, the so-called *soft sensor* approach. Mid infrared spectroscopy (MIR) generally has a lower detection limit than near infrared spectroscopy (Roychoudhury P. et al.). The emerging PAT-tool acoustic chemometrics (a.c.) is also believed to carry a great potential within the field of monitoring and controlling of biorefining processes. Acoustic chemometrics can e.g. control the solid concentration levels on-line by using a simple “clamp-on” accelerometer.

#### **Perspectives for integration of PAT in production of bioenergy and renewable energy**

Spring 2008, the price for crude oil exceeds the psychological limit of USD 100 per barrel, indeed overshoot to USD 125 in only a few days in May 2008. The effects of political unrest and adverse climatic impact is also involved behind the sharply increased prices that have to be paid for important primary resources to keep the society operating including energy, food, commodities and consumables (May 2008). For these reasons, as well as others, the need for a *change of paradigm* from fossil fuels to

renewable energy resources is manifestly clear in order to contribute to stabilise the basis for future developments and satisfy the demands for higher living standards globally, both to make the industrialised part of the world more balanced and sustainable, but even more importantly in the developing world, to develop more fair trade and rapidly increase the living standard.

The academic society has by now clearly acknowledged the existence of environmental impacts caused by side-effects of the ever growing consumption of fossil fuels. Extreme weather conditions manifested in for instance heat waves, forest fires, and massive precipitation are occurring more frequently than ever before. An elevated global average temperature has been observed and documented by the Intergovernmental Panel on Climate Change: increased emission of greenhouse gasses, mainly carbon dioxide, methane, and nitrous compounds is the primary cause of the global temperature increase (IPCC 2007). Thus, energy production based on fossil fuels can be linked directly to these natural disasters claiming many casualties and necessitating tremendous reconstruction efforts.

At present, fossil energy resources account for 79 % of the world's energy consumption, 7 % is covered by nuclear power, and renewable energy sources deliver the remaining 14 % [European Commission 2005]. Diversity in the energy product portfolio is necessary in order to reduce the dependency on any single energy source [Logan 2006]. Naturally, all energy products of interest must conform with today's absolute requirements: they must be sustainable, renewable, and clean. No single renewable energy technology should be preferred on expense of others. In the long term, the global energy supply can only be secured through an intelligent integration of various renewable energy sources.

A recent Danish study estimates that 75 % of the world's energy consumption can be covered by careful utilisation and management of all renewable energy sources within the time span 2030-2050. This study calls for a true change of paradigm, which is needed to shift the industrialised societies from being dependent on fossil fuel to become economies based on renewable energy sources – solar, wind, waves, hydro and biomass. This can happen, if-and-only-if immediate action and massive political and economic support from all regions of the world is at hand. [Holm Nielsen et. al. 2007c]

The research reported in this paper constitute a small, but hopefully valuable step on the way to realize establishment of economically feasible, highly integrated, and highly efficient *biorefineries* capable of treating a diverse portfolio of organic substrates with the aim of providing clean, renewable energy and a wide range of other high-value products to the growing and demanding global society. Effective management of the AD process for biogas energy production constitutes an integral element in this context.

## **Acknowledgements**

Bygholm trials. The Department of Agricultural Engineering, Faculty of Agricultural Sciences, Aarhus University is greatly appreciated for very fruitful cooperation during the autumn of 2006.

LinkoGas A.m.b.A.. The authors would like to thank the management team at Linkogas for an always very open-minded collaboration, and as well the laboratory technicians Dorte Spangsmark at Aalborg University Esbjerg and her team for kind assistance with the reference analyses at AAUE.

## References

Al Seadi, T. (2001). Good practice in quality management of AD residues from biogas production. International Energy Agency, Task 24- Energy from Biological Conversion of Organic Waste. Published by IEA Bioenergy and AEA Technology Environment, Oxfordshire, United Kingdom, 2001.

Amon, T., Amon, B., Kryvoruchko, V., Bodiroza, V., Pötsch, E., and Zollitsch, W. (2006). "Optimising methane yield from anaerobic digestion of manure: Effects of dairy systems and of glycerine supplementation", Elsevier, International Congress Series, vol. 1293, pp. 217–220, DOI: 10.1016/j.ics.2006.03.007

Baggesen D.L., (2007). Veterinary safety in relation to handling of manure and animal by-products and the use of biogas technology. European workshop 14-16. June 2007, Esbjerg, Denmark. Proceedings – The Future of Biogas in Europe III; Intelligent Energy – Europe; Workshop co-financed by European commission, the PROBIOGAS project (EIE/04/117/S07.38588)

Bakeev, K.A. (editor) (2005). "Process Analytical Technology — Spectroscopic tools and implementation for the chemical and pharmaceutical industries", Blackwell Publishing, Oxford, United Kingdom, pp. 1-451, ISBN: 1-4051-2103-3

Benabdallah El-Hadj, T. (2006). "Biodegradation of organic micropollutants in thermophilic and mesophilic anaerobic digestion of sewage sludge", Ph.D. dissertation, Department of Chemical Engineering, Faculty of Chemistry and Physics, University of Barcelona, Spain, p. 11, ISBN: 84-690-2982-7

Böhm R., Wellinger A. (1999). Hygienic and environmental aspects of anaerobic digestion – legislation and experiences in Europe. IEA Workshop Task-group 24 & Deutsche Veterinärmedizinische Gesellschaft (DVG): Jointly organized by; Institute für Umwelt- und Tierhygiene sowie Tiermedizin mit Tierklinik der Universität Hohenheim, Germany & Nova Energie GmbH, CH-8356 Ettenhausen, Switzerland. Vol 1. - ISBN 3-930511-62-2 and Vol. 2 – ISBN3-930511-65-7.

Christensen, J., Hjort-Gregersen, K., Uellendahl, H., Ahring, B.K., Baggesen, D.L., Stockmarr, A., Møller, H.B., and Birkmose, T. (2007). *Future biogas plants - New systems and their economic potential*, Institute of Food and Resource Economics, University of Copenhagen, Denmark, report no. 188, ISBN 978-87-92087-07-2 (in Danish)

Esbensen, K.H., "Multivariate Data Analysis — in Practice", 5<sup>th</sup> edition, CAMO Process ASA, Oslo, Norway, pp. 1-598, ISBN: 82-993330-3-2 (2002)

Esbensen, K. H. and Petersen, L.: Sampling in Practice: a TOS Toolbox of Unit Operations. Proceedings, Baltic Biorefinery Symposium, ISBN: 87-7606-009-9 Esbjerg, Denmark, 2005

Esbensen, K. H. et al.: Procesprøvetagning – er slet ikke så ligetil, 1. del Særtryk fra Dansk Kemi og Plus Process, Introduktion til repræsentativ prøvetagning for stationære og dynamiske systemer, ACABS, Aalborg Universitet Esbjerg (AAUE), Danmark, 2006 (In Danish)

Esbensen, K. H. et al.: Procesprøvetagning – er slet ikke så ligetil, 2. del Særtryk fra Dansk Kemi og Plus Process, Introduktion til repræsentativ prøvetagning for stationære og dynamiske systemer, ACABS, Aalborg Universitet Esbjerg (AAUE), Danmark, 2006 (In Danish)

Esbensen, K. H. et al.: Sampling I – "the missing link" for analytisk kemi og kemometri Særtryk fra Dansk Kemi og Plus Process, Introduktion til repræsentativ prøvetagning for stationære og dynamiske systemer, ACABS, Aalborg Universitet Esbjerg (AAUE), Danmark, 2006. (In Danish)

European Commission (2005). *Biomass – Green energy for Europe*, Directorate-General for Research, Directorate J – Energy, ISBN: 92-894-8466-

Gy, P., "Sampling for Analytical Purposes", Wiley and Sons, pp. 1-153, ISBN: 0-471-97956-2 (1998)

Harris, D.C. (2003). "Quantitative chemical analysis", 6<sup>th</sup> edition, 2<sup>nd</sup> printing, W.H. Freeman and Company, New York, United States, pp. 407-432, ISBN: 0-7467-4464-3

Holm-Nielsen J.B., Halberg N., Huntingford S., Al Seadi T.: (1993 & 1997). Joint Biogas Plant – Agricultural Advantages – circulation of N, P and K. Report for the Danish energy Agency, March 1993, revised and emended edition, August 1997.

Holm-Nielsen J.B., Dahl C.K., Esbensen K.H.: Representative sampling for process analytical characterisation of heterogeneous bioslurry systems – a reference study of sampling issues in PAT. *Chemometrics and intelligent laboratory systems* vol. 83, 114 – 126 (2006) ScienceDirect, Elsevier. DOI: 10.1016/j.chemolab.2006.02.002

Holm-Nielsen, J.H., Andree, H., Lindorfer, H., and Esbensen, K.H., "Transflexive embedded near infrared monitoring for key process intermediates in anaerobic digestion/biogas production", *Journal of Near Infrared Spectroscopy*, vol. 15, pp. 123-135 (2007, a), DOI: 10.1255/jnirs.719

Holm-Nielsen, J.H., Lomborg, C.J., Oleskowicz-Popiel, P., and Esbensen, K.H., "On-line Near Infrared monitoring of glycerol-boosted anaerobic digestion processes —

evaluation of Process Analytical Technologies”, Wiley, Journal of Biotechnology and Bioengineering, vol. 99 (issue 2), pp. 302-313 (2007,b), DOI: 10.1002/bit.21571

Holm Nielsen, J.B., Oleskowicz-Popiel, P., and Al Seadi, T. (2007,c). *Energy crop potential for bioenergy in EU-27*, 15<sup>th</sup> European Biomass Conference and Exhibition – From Market Research to Deployment, proceedings, Berlin, Germany

Junker, B.H., and Wang, H.Y. “Bioprocess monitoring and computer control: key roots of the current PAT Initiative”, Wiley Periodicals, Biotechnology and Bioengineering, vol. 95 (issue 2), pp. 227-261 (2006), DOI: 10.1002/bit.21087

Kamm, B., Gruber, P.R., and Kamm, M. (editors) (2006). “Biorefineries – industrial processes and products. Status quo and future directions”. vol. 1, Wiley-VCH Verlag, ISBN: 3-527-31027-4

Logan, B.E. (2006). *Energy diversity brings stability — comment*, American Chemical Society, Environmental Science & Technology, vol. 40, issue 17, p. 5161

Martens H. and T. Næs, 1991: Multivariate Calibration, Updated version, John Wiley and Sons.

Mortensen, P.P., “Process Analytical Chemistry — Opportunities and problems for bio-industrial implementation”, Ph.D. dissertation, Aalborg University, Esbjerg Institute of Technology, ACABS research group, pp. 1-68, ISBN: 87-7606-017-9 (2006)

Nielsen, B.H.: Control parameters for understanding and preventing process imbalances in biogas plants. Ph.D Thesis, Environmental Microbiology & Biotechnology Research Group, DTU, Copenhagen, 2005.

Nielsen L.H., Hjort-Gregersen K., Thygesen P., and Christensen, J. (2002). Socio-economic Analysis of Centralised Biogas Plants. Research report no. 136, Danish Research Institute of Food Economics, Copenhagen, Denmark. [www.foi.dk](http://www.foi.dk); ISSN 0106-1291.

Petersen, L., C.K. Dahl, K.H. Esbensen, “Representative mass reduction in sampling — a critical survey of techniques and hardware”, Journal of Chemometrics and Intelligent Laboratory Systems 74, pp. 95–114 (2004), DOI: 10.1016/j.chemolab.2004.03.020

Petersen, L., Minkinen, P., and Esbensen, K.H., ”Representative sampling for reliable data analysis: theory of sampling”, Journal of Chemometrics and Intelligent Laboratory Systems 77, pp. 261–277 (2005), DOI: 10.1016/j.chemolab.2004.09.013

Petersen, L., and Esbensen, K.H., “Representative process sampling for reliable data analysis — a tutorial”, Journal of Chemometrics, vol. 19 (issue 11–12), pp. 625–647 (2005), DOI: 10.1002/cem.968

Pitard, F.F. , “Pierre Gy's sampling theory and sampling practice, Heterogeneity, Sampling Correctness, and Statistical Process Control”, CRC Press, LLC, pp. 1-488, ISBN: 0-8493-8917-8 (1993)

Roychoudhury P., Harvey L.M., McNeil B. (2006). The potential of mid infrared spectroscopy (MIRS) for real time bioprocess monitoring. Elsevier, *Analytica Chimica Acta* 571, p. 159 – 166. doi: 10.1016/j.aca.2006.04.086.

Thomsen, M.H. *Complex media from processing of agricultural crops for microbial fermentation*, Springer-Verlag, *Appl. Microbiol. Biotechnol.*, vol. 68, pp. 598-606 (2005), DOI: 10.1007/s00253-005-0056-0

End of Thesis !



<http://orbits.eoportal.org/orbits.html>

11 Jul. 08 ,07:38:28 UTC

### **An Indian Prayer:**

Oh Great Spirit,  
Whose Voice I hear in the wind,  
Whose breath gives life to the world,  
hear me!

I come to you as one of your many children,  
I am small and weak,  
I need your strength and wisdom.  
May I walk in beauty,  
make my eyes behold the red and purple sunset,  
make my hands respect the things that you have made,  
and my ears sharp to hear your voice.

Make me wise so that I may know the things  
that you have taught your children,  
the lessons that you hidden in every leaf and rock.  
Make me strong....not to be superior to my brothers,  
but to be able to fight my greatest enemy...myself.

Make me ever ready to come to you with straight eyes,  
so that when life fades as the fading sunset,  
my spirit will come to you without shame.

(Source – Tribes and Nations)