



AALBORG UNIVERSITY
DENMARK

Aalborg Universitet

Optical activation of excitable cells

application of photosynthetic reaction centers

Pennisi, Cristian Pablo

Publication date:
2008

Document Version
Publisher's PDF, also known as Version of record

[Link to publication from Aalborg University](#)

Citation for published version (APA):

Pennisi, C. P. (2008). *Optical activation of excitable cells: application of photosynthetic reaction centers*. Center for Sensory-Motor Interaction (SMI), Department of Health Science and Technology, Aalborg University.

General rights

Copyright and moral rights for the publications made accessible in the public portal are retained by the authors and/or other copyright owners and it is a condition of accessing publications that users recognise and abide by the legal requirements associated with these rights.

- Users may download and print one copy of any publication from the public portal for the purpose of private study or research.
- You may not further distribute the material or use it for any profit-making activity or commercial gain
- You may freely distribute the URL identifying the publication in the public portal -

Take down policy

If you believe that this document breaches copyright please contact us at vbn@aub.aau.dk providing details, and we will remove access to the work immediately and investigate your claim.

**Optical activation of excitable cells:
Application of photosynthetic reaction centers**

Ph. D. thesis
by
Cristian Pablo Alejandro Pennisi

Center for Sensory Motor Interaction (SMI)
Department of Health Science and Technology
Aalborg University, Denmark
2008

ISBN 978-87-90562-97-7

Table of contents

<i>Acknowledgements</i>	4
<i>English summary</i>	5
<i>Danish summary / Dansk Sammenfatning</i>	6
1. Introduction	7
1.1. Electrical stimulation: application and limitations	7
1.2. Optical control of cell activation	8
1.3. Photosystem I: a molecular photovoltaic device	11
1.4. Aims of the present project	14
1.5. Description of the project	15
References	16
2. Spatial Distribution of the Electric Potential from Photosystem I Reaction Centers in Lipid Vesicles	22
3. Analysis of Light Induced Transmembrane Ion Gradients and Membrane Potential in Photosystem I Proteoliposomes	23
4. Incorporation of Photosynthetic Reaction Centers in the Membrane of Human Cells: Toward a New Tool for Optical Control of Cell Activity	24
5. General discussion	25
5.1. Introduction	25
5.2. Discussion of the main results	25
5.2.1. Charge separation potential as source of cell activation	25
5.2.2. Analysis of the closed circuit response	26
5.2.3. Comparison of the alternatives	28
5.2.4. Incorporation of PSI in cells	28
5.3. Methodological considerations	29
5.3.1. Methodological design of the project.....	29
5.3.2. Theoretical models.....	30
5.3.3. Experimental model.....	30
5.3.4. Reconstitution procedure	31
5.4. Perspectives	32
5.5. Conclusions	33
References	34

Acknowledgements

This thesis is the primary result of four years of work, mostly performed at the Center for Sensory-Motor Interaction (SMI), Aalborg University (AAU). I am very grateful to all the people and institutions that, in a way or another, have supported me during the realization of this work. I am especially grateful to the Danish Research Foundation for providing the financial support which gave me the opportunity to carry out this PhD study.

In particular, I would like to express my most sincere gratitude to my supervisor, Ken Yoshida, for his guidance and support at all stages of my work. Besides contributing to the initial ideas of this very interesting project, he has provided constructive criticism and suggestions that were fundamental for the success of this research effort. I am also grateful to Winnie Jensen, for her constructive criticism and support, especially during the final part of my work. Thanks also to my office mate and friend Cristian Sevcencu, for sharing with me more than the research interests and for his constant encouragement and suggestions. I am thankful to all my friends, colleagues, technical and administrative personnel from SMI who have helped me in many ways throughout this endeavor.

Part of this work is the result of collaborative efforts with people from other institutions. I would like to express my gratitude to Dr. Elias Greenbaum, from Oak Ridge National Laboratory, USA (ORNL), for contributing to the initial ideas of this project and for his support, mainly through long fruitful discussions over the phone. I am also grateful to Miguel Rodriguez Jr., from ORNL, for providing PSI samples and valuable experimental protocols. I am also indebted with Prof. Poul Erik Jensen, from the Molecular Plant Biology Laboratory at University of Copenhagen, for his great support in the experimental tasks related with the purification and characterization of the plant samples, in particular for his unreserved assistance during some of the most critical parts of this work. I wish to thank to the staff members from the Laboratory for Stem Cell Research (LSR) at AAU, in particular to Prof. Vladimir Zachar for his valuable suggestions and to Helle Skjødt for her assistance in the cell culturing procedures. I also wish to thank to Professor Daniel Otzen, formerly at the Section of Biotechnology at AAU, for facilitating me the equipment I have used to produce and characterize the lipid vesicles.

I also wish to thank to my family in Argentina for the constant encouragement, in particular my dad for his permanent support and for being an example of perseverance. I also wish to thank to my friends from Argentina, especially to my colleagues from the University of Entre Rios for their support during my leave of absence.

Last but not least, I would express my most sincere gratitude to my wife, Jorgelina, and my children, Valentina and Lorenzo, for their love, understanding and support. This thesis is dedicated to them.

English summary

Electrical stimulation of excitable cells by means of extracellular electrodes has some limitations that have motivated the development of alternative methods. Among these are methods that use light as a trigger to activate the cells. These recent developments have shown their utility mostly in basic neuroscience research, but in their current form, their suitability for clinical application is very limited. However, recently, a novel optical activation method has been proposed which has greater suitability for clinical use. This method is based on the photosystem I (PSI) reaction center, a pigment-protein membrane complex from photosynthetic membranes, which can be delivered to the target cell's membrane using a proteoliposome delivery system. PSI develops a charge separation potential which forms after a photon is absorbed by the reaction center. This light activated potential could then be used to trigger endogenous voltage-dependent ion channels to activate the cell. However, this hypothesis has not been validated yet. The aim of this thesis was to provide support to this hypothesis.

In the first two studies of the thesis, computational models which aim to understand the characteristics of the electric potential produced by PSI inserted in a lipid vesicle were developed. In study I, it was found that the transmembrane potential generated by PSI in the 'open-circuit' configuration strongly depends upon the ionic strength of the external electrolytes. Thus, to provide cell activation using this configuration in physiological conditions, it would be necessary to cluster several PSIs close to an ion channel. In study II, the transmembrane potential generated by PSI operating in the 'closed-circuit' configuration was obtained. The main conclusion was that this configuration could not be used for fast cell activation due to the slow onset of the potential. In study III, PSIs reconstituted in proteoliposomes were delivered to human cells in culture. The aim of this study was to investigate if heterologous membrane incorporation of PSIs is feasible. The results of this study showed that PSIs can be incorporated in mammalian cell membranes preserving their native orientation. Besides, it was also shown that the incorporation process does not cause significant cell damage.

In conclusion, the present work indicates that PSI can be incorporated in the membrane of mammalian cells and that certain conditions are required in order to develop a voltage stimulus appropriate for channel activation. These results support the use of PSI for optical activation of excitable cells and should be considered as a basis for future research efforts in the subject.

Danish summary / Dansk Sammenfatning

Elektrisk stimulation af excitable celler ved hjælp af ekstracellulære elektroder har flere begrænsninger. Dette har motiveret forskere til at udvikle alternative metoder til aktivering af celler. Disse metoder er baseret på brugen af lys til at trigge celleaktivering, hvilket er en yderst anvendelig teknik indenfor grundforskningen, men perspektiverne for en egentlig klinisk anvendelse er stadig stærkt begrænset. Derfor er en ny optisk aktiveringsmetode for nyligt blevet foreslået, baseret på fotosystem I (PSI) reaktions center, som er et membranbundet pigment-protein kompleks fra fotosyntetiske membraner. Det primære formål med denne afhandling var at undersøge hypotesen om at PSI udvikler et ladningsseparations-potentiale efter lys absorption, som kan benyttes til at aktivere spændingsstyrede ionkanaler

I de to første studier af denne tese, udførtes computer modelleringer med det formål at estimere det elektriske potentiale produceret af PSI indsat i en lipid vesikel. Studie I, viste at det transmembrane potentiale generet af PSI i en 'åbent kredsløb' konfiguration, var meget afhængig af ion koncentrationen i den eksterne elektrolyt opløsning. For at fremkalde en egentlig celleaktivering ved brug af den åbne kredsløbs konfiguration under fysiologiske forhold, vil det være nødvendigt at samle flere PSI'er tæt på en ionkanal. Studie II, estimerede det transmembrane potentiale genereret af PSI i en 'lukket kredsløb' konfiguration. Konklusionen på dette studie var at denne konfiguration ikke var brugbar til generering af en hurtig celleaktivering på grund af en for langsom potentiale stigning. Under studie III, blev PSI rekonstitueret i proteoliposomer tilføjet til human cellekulturer. Formålet med dette studie var at undersøge om heterolog membran indlejring af PSI var muligt. Resultatet af dette studie viste at PSI kan indlejres i mammale cellemembraner og samtidigt bevare deres oprindelige orientering. Det blev yderlig vist at indlejningsprocessen ikke forårsagede signifikant skade på cellerne.

Arbejdet indiker at PSI kan indlejres i mammale cellemembraner, og at bestemte forhold kræves for at udvikle et spændings stimuli egnet for ionkanal aktivering. Resultaterne fra studierne indikerer at brugen af PSI til optisk aktivering af excitable celler er mulig, og arbejdet bør ses som en basis for yderlige forskningsinitiativer inden for området i fremtiden.

1. Introduction

1.1. *Electrical stimulation: application and limitations*

Excitable cells, like for instance neurons and muscle cells, are cells that respond actively to an external perturbation, including electrical, mechanical, thermal and chemical stimuli. Since Galvani's experiments with frog's legs in the eighteenth century, electrical stimulation has been the most used methodology to elicit the activation of excitable cells [1]. Methods and devices based on electrical stimulation have been remarkably useful for basic research on the nervous and muscular systems, under normal and pathologic conditions. They have also provided important contributions in the area of medical therapy, in particular for the development of prosthetics [2-4]. In this regard, advanced implantable prosthetic devices are available in the clinical practice for the treatment of several disorders impairing sensory, cognitive and motor functions [5;6]. Some few examples of these devices are sensory prosthetics [7;8], stimulators for the treatment of brain disorders [9] and functional neuromuscular stimulators [10].

In general, an implantable device used for electrical stimulation consists in at least an electronic unit, in charge of generation of the electrical impulses, and an electrode, the technical element that interfaces the electronic unit with the excitable structures. The electrode is located in close vicinity to the cells, in a way that local electric fields can modify the extracellular potential. Stimulus of appropriate level trigger the opening of voltage-sensitive ion channels in the membrane of the cells, producing their consequent activation. However, despite many of its advantages, this way of achieving cellular activation possesses the following limitations:

- *Limited spatial selectivity.* With an extracellular electrode it is technically difficult to stimulate selectively one or few cells within a tissue. Due to constraints in the electrode size and the electric spread of the stimulus, not only the cells that are immediately adjacent to the electrode are stimulated but also many others surrounding that region [11]. Microstimulation techniques for neural tissue have been developed, in which the size of the electrodes and the stimulation levels are minimized [12]. Even though the number of stimulated elements is reduced, it is very difficult to identify and to quantify them [13]

- *Limited cellular specificity.* When stimulating larger areas of tissue using electrical stimulation, it is difficult to discriminate between different types of cells in order to target specific populations. For instance, in the deep brain stimulation technique used for the treatment of movement related disorders, unintended stimulation of non targeted brain regions can induce serious side effects [14]. Another example is the use of electrical stimulation for activation of muscles, where muscle fibers are recruited without sequencing related to fiber types leading to increased muscle fatigue in contrast with voluntary activation [15]

- *Limited capacity of parallel stimulation.* It is not possible to address in parallel members of a geometrically dispersed population of cells without increasing the number of active sites or electrode units. Examples of this are the prosthetics for the chronic stimulation of retina, which require a large number of electrodes and therefore face significant technical and biological problems [16]

- *Stimulation artifact.* Stimulation artifacts plague neuroscience research, impeding the recording of events very close to the instant of stimulation. For instance, those affecting local field potentials recordings obtained during deep brain stimulation, which are only possible to remove after off-line processing [17].

Other issues related to electrical stimulation devices include sensitivity of the probes to electromagnetic interference and a poor electrical and mechanical stability of the electrodes in long term applications.

1.2. Optical control of cell activation

The above mentioned problems have motivated the present PhD project, as well as several other research initiatives, towards the development of an alternative practical method for the activation of excitable cells. The key to avoid the large inefficiencies of extracellular activation lies in a method capable of directly triggering the opening of ion channels as a means to influence the cell's transmembrane potential. Using this principle, methods that apply light to control cell activity have emerged during recent years. These methods have shown promise to varying degrees to address most of the issues of electrical stimulation. They offer the possibility of fast, spatially selective, contact and artifact-free stimulation and have been basically applied in neuroscience research [18;19]. The general principles of these methods will be reviewed in the following paragraphs and are summarized in Fig. 1.

Direct stimulation: Using a low energy, pulsed laser light, Wells et al. were able to evoke action potentials in amphibian and mammalian peripheral nerves [20]. The transmembrane sodium ion channels are activated as a result of the thermal transient caused by the laser, eliciting neural action potentials without causing histological tissue damage (Fig. 1.a) [21]. Although it elicits highly controlled, artifact-free potentials in a non-contact fashion, the stimulating light beam remains as the functional equivalent of an electrode, exerting its effect at only one focal point at a time.

Optical release of caged agonists: Photostimulation has also been possible thanks to the development of caged neurotransmitters [22]. Cellular agonists are inactivated with a photoremovable blocking group and delivered to the target tissues. Then, using illumination it is possible to induce a concentration jump of the transmitter, which enables the activation of the targeted cells (Fig 1.b) [23]. The agonist can exert its action over the cells natural receptors, like for instance the glutamate receptors, which normally induces the simultaneous activation of a large number of cells [24]. To increase the selectivity, cells can be genetically targeted to express exogenous proteins sensitive to a particular agent,

like for instance capsaicin [25]. Caged agonists have been successfully used in the study of diverse aspects of neurotransmission in neuronal circuits [23;26]. However, the method cannot be used to support sustained activity, due to the accumulation of desensitized receptors and the local depletion of caged compounds [27].

Exogenous expression of photosensitive membrane proteins. Several types of photosensitive proteins have been genetically expressed in normally insensitive cells to control the cellular activation. Melanopsin, a photoreceptor protein found in retinal ganglion cells, can support light evoked responses when expressed in mammalian cell lines [28]. However, the control of membrane potential is indirect because depends on a signaling cascade mechanism (Fig. 1.d). Channelrhodopsin-2 (ChR2), a channel protein found in green algae, has been also used to confer light sensitivity to neurons and other cells [29-31]. ChR2 is a non-selective cation channel, which unlike melanopsin can induce direct cell activation and support repetitive firing when illuminated (Fig. 1.e.). Recently, the light-driven chloride pump halorhodopsin (NpHR) has been co-expressed with ChR2 in neurons as a mean to provide light-dependent inhibition [32], allowing bidirectional optical control of cell excitation. Another approach that requires exogenous expression, involves the use of a photoisomerizable compound (a 'photoswitch') attached onto a voltage-gated channel. The engineered hybrid ion channel can be turned on and off with light, controlling the cell excitability in a reversible fashion (Fig 1.f) [33;34]. The above mentioned methods can provide a high degree of selectivity and therefore have a tremendous potential in neuroscience research [35;36]. However, as the genetic expression might perturb the development and function of the cells expressing the genes, the application of these methods in the clinical practice raises ethical and safety concerns.

Photosensitization of endogenous ion channels. In a recent report, Fortin et. al have described a new optical regulation method that do not require a genetic expression mechanism [37]. In this approach, a synthetic photoisomerizable molecule that specifically targets endogenous K^+ channels is externally delivered to the cells, transforming them into light-sensitive. Light switches the channel between functional and disabled state, modulating cell excitability (Fig 1.c.). The method does not allow direct cell activation, but it represents a promising non-genetic approach to confer light-sensitivity to normally insensitive cells.

Approaches employing endogenous membrane proteins

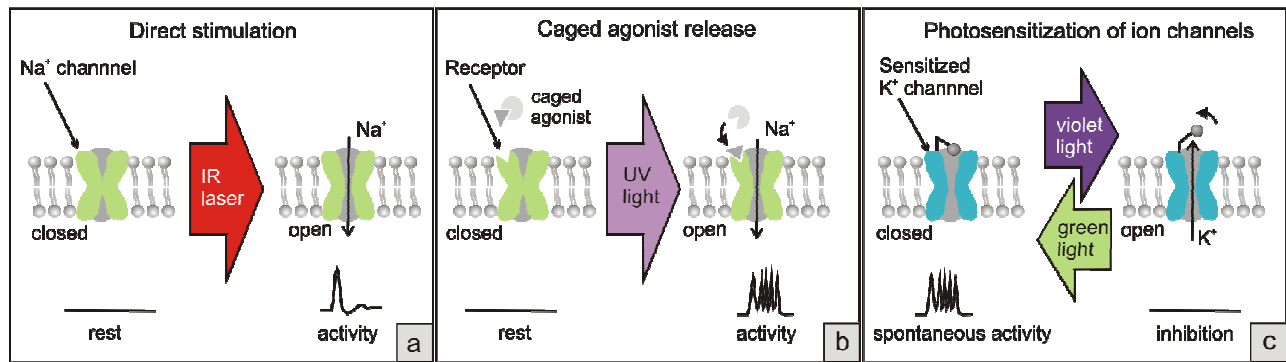

Approaches employing expression of exogenous membrane proteins

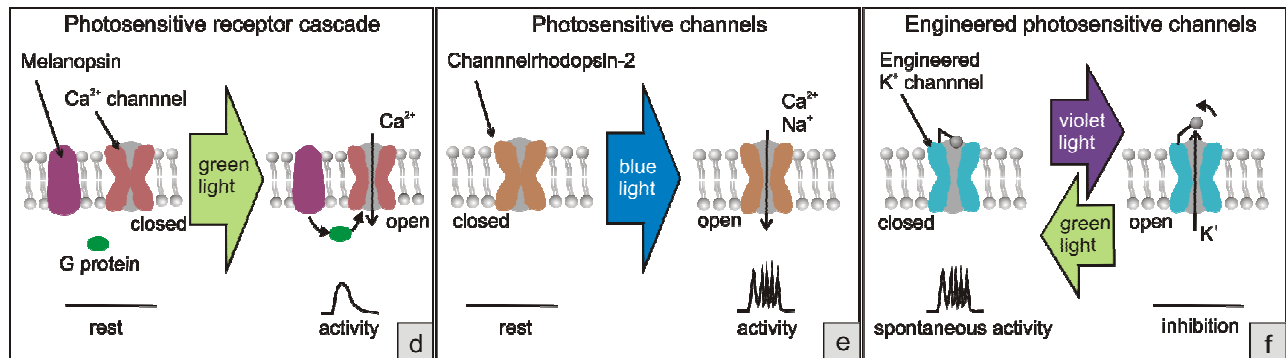

Fig. 1: Overview of the state-of-the-art methods used to confer light sensitivity to normally insensitive cells. Each panel schematically represents a portion of the cell membrane and the involved structures (on top) and the temporal course of the associated membrane potential (below), before and after application of light. Panels (a) to (c) are the approaches that utilize the cell's endogenous receptors, while panels (d) to (f) are the approaches requiring expression of the photosensitive proteins in the host cells. (adapted from [38]).

In summary, it is clear that light-based activation methods can overcome most of the problems associated with electrical stimulation. However, while each of the above presented methods has demonstrated its usefulness in diverse areas of neuroscience research, none of them seems to be well suited for application in the field of neuroprostheses. Issues that still need to be addressed include lack of spatial selectivity and resolution (Fig. 1.a, direct method), inability of supporting sustained activity (Fig. 1.b, release of caged compounds), inability of providing direct cell activation (Fig. 1.c, photosensitization) and need of genetic manipulation (Fig. 1.d-f, exogenous expression methods).

1.3. Photosystem I: a molecular photovoltaic device

The photosystem I (PSI) reaction center is a pigment-protein complex located in the photosynthetic membranes of cyanobacteria, algae and plants. PSI is the one of the most studied photosynthetic reaction centers, from both a structural and a functional point of view [38-40]. This reaction center functions as a light-driven enzyme in the thylakoid membrane (an oxidoreductase) that catalyzes the electron transfer from plastocyanin on the luminal side to ferredoxin at the stromal side [41]. The complex is constituted by 11-14 different protein subunits and several organic and inorganic cofactors. The core of the complex is formed by three protein subunits (PsaA, PsaB and PsaC) which bind approximately 100 chlorophyll molecules (antenna pigments) and a central group of electron transfer cofactors. These cofactors represent the transmembrane electron transfer pathway. Fig. 2 is a schematic representation of PSI, where the subunits and the electron transfer chain are illustrated.

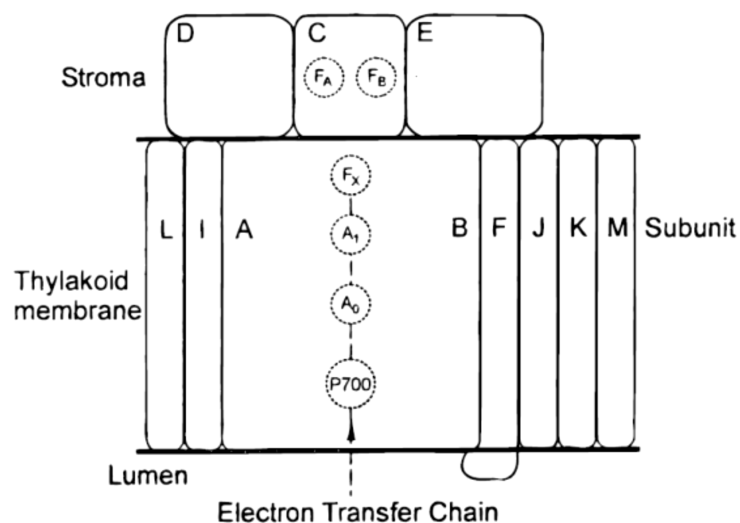

Fig. 2. Illustration of the subunit composition of the cyanobacterial PSI. The subunits are indicated by the last letter of their acronyms (f.x. A for PsaA). The cofactors of the electron transfer chain are represented by dotted circles. (extracted from [42]).

When a photon is captured by one of the antenna pigments, its energy is transferred to a specialized chlorophyll dimer, known as P700, which is located near the luminal side. Then, P700 is excited and the electron transfer process in PSI begins. In its excited state (P700*), this molecule is an extremely strong reducing agent and readily gives up the electron to the primary acceptor, a chlorophyll molecule known as A₀. Subsequently, the electron is transferred to the rest of the chain that includes a philloquinone molecule (A₁) and three [4Fe-4S] clusters, F_X, F_A and F_B. Due to the experimental difficulties in distinguishing kinetically F_A and F_B, these two clusters are frequently referred to as F_A/F_B

or $F_{A/B}$. This cluster is the terminal electron donor, which reduces soluble ferredoxin with the ultimate purpose of reducing $NADP^+$ to $NADPH$. Photo-oxidized P700 ($P700^+$) is rereduced by plastocyanin (although in some organisms by cytochrome c). This charge separation process from P700 to $F_{A/B}$ is carried out in less than 200 ns. Fig. 3 shows the typical lifetimes for each of the forward reactions in the chain, indicating also the midpoint redox potential for each cofactor.

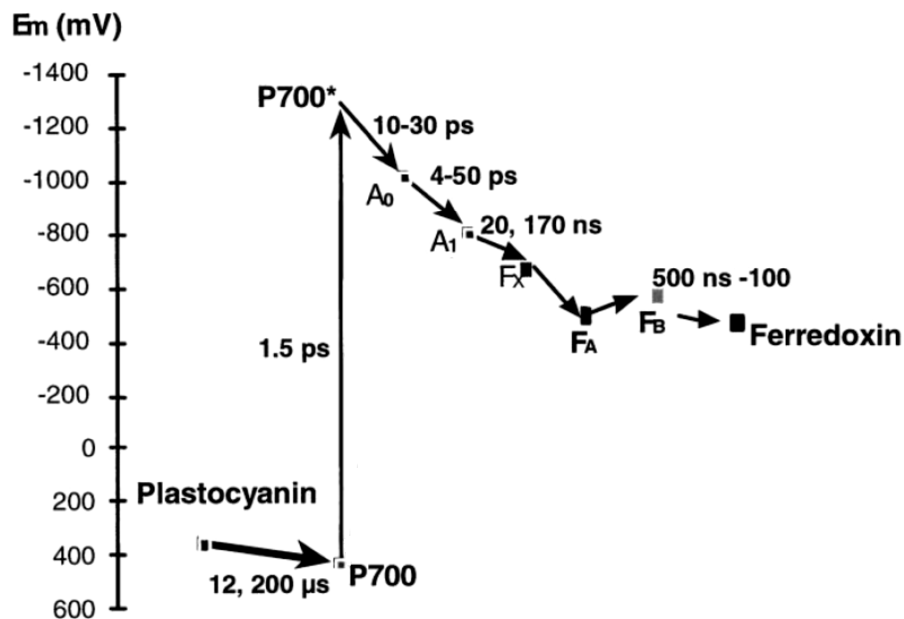

Fig. 3. Energy-kinetic diagram of the electron transfer chain in PSI. The typical lifetimes for each of the forward electron transfer reactions between cofactors is indicated. (modified from [41]).

The above described charge separation process from P700 to $F_{A/B}$ is electrogenic. An electric potential is associated with the separated species $P700^+$ and $F_{A/B}^-$ [43]. This charge separation potential has been experimentally measured in diverse membrane preparations in response to light flashes [44-47]. Under continuous illumination and in absence of external soluble cofactors or any artificial carrier, the separated charges remain associated with the complex forming a dipole that spans the membrane. In analogy to a photovoltaic device, it is said that the complex is in ‘open circuit’ configuration. Using the technique of Kelvin force probe microscopy, the open circuit potential measured from isolated complexes was in the range of 1 V [42]. On the other hand, in presence of natural or artificial external carriers donating and accepting electrons at the opposite ends of the complex, there is a flux of charges in response to continuous illumination. This can be interpreted as the ‘closed circuit’ configuration for the complex and in certain conditions an electric potential due to transmembrane movement of protons is also generated. The closed circuit response has been measured in diverse isolated PSI preparations using indirect techniques [48-51], although the electric potential magnitude has not been obtained.

In addition to the above mentioned characteristics, PSI has a nanometer-scaled robust structure and the ability to be isolated and embedded onto different types of substrates for long periods. These features have made of PSI an attractive biomolecular optoelectronic device for diverse applications [52-56]. In particular, PSI has been proposed as an alternative approach for the activation of excitable cells. It was suggested that the either in “open” or “closed-circuit” configuration, the light-generated potential might have enough magnitude to trigger cellular responses mediated by voltage-activated ion channels [57]. The basic concept is illustrated schematically in Fig. 4.

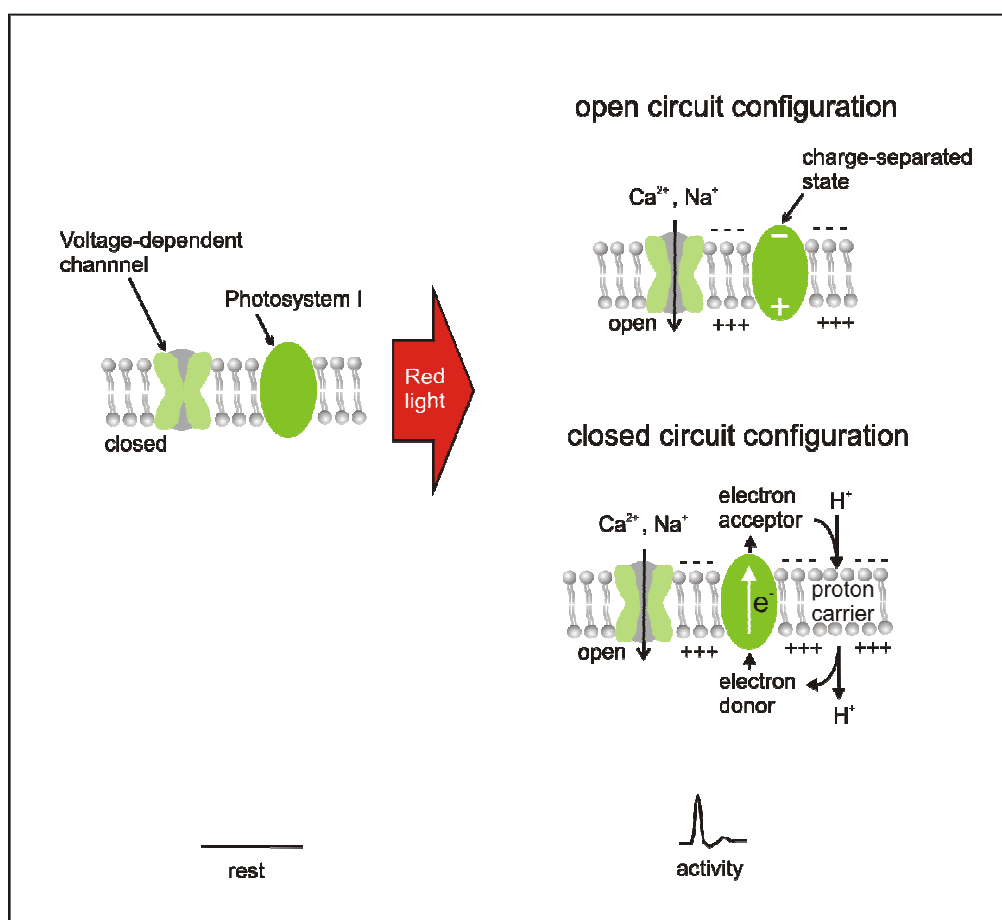

Fig. 3. The hypothesis of cell activation using Photosystem I as trigger of voltage-dependent ion channels. In the open circuit configuration, light-induced charge separation potential in PSI leads to membrane depolarization, which opens the channels and causes cell activation due to cation influx. In the closed circuit configuration, the presence of external carriers cause a continuous flux of electrons across PSI and also a proton influx across the membrane, which generates a membrane depolarization that leads to the channel opening. The temporal course of the expected cell membrane potential associated with each state is indicated at the bottom of the figure. When the cell is at rest, the potential is almost constant (resting potential). When the channels are triggered by membrane depolarization, the cell develops an active response (action potential) (adapted from [57]).

The light-induced charge separation process in PSI is very fast ($<1 \mu\text{s}$) and can be repeatedly triggered due to self-regenerative charge recombination in the dark [45]. In addition, the delivery of the complexes does not require a modification of the cell genetic material because it could be done using proteoliposomes prepared from purified fractions [57]. In principle, these are two required features for an optical activation method intended for application in neuroprostheses. The first experimental indication of the capacity of PSI to provide light-dependent cell activation was obtained with retinoblastoma cells treated with PSI proteoliposomes [58]. After the treatment, the cells showed a slow increase of the intracellular calcium in response to light, but the mechanism behind this response could not be explained. Thus, the study did not provide conclusive evidence that could validate the hypothesis of activation of voltage-dependent channels by PSI. Besides, it was not directly shown that the complexes were incorporated in the membrane of the cells.

1.4. Aims of the present project

As it should be evident from the above paragraphs, the PSI reaction center seems to be well suited for application in optical activation of cells, but the hypothesis of activation of voltage-dependent ion channels using PSI has not been yet confirmed. There are several questions that need to be answered before further experimental work. First of all, when the complex is embedded in a membrane, which are the characteristics of the electric potential that develops under open and closed circuit configurations? Is it any of the two configurations more appropriate for the activation of voltage-activated channels? And after that, is it feasible to correctly insert these membrane complexes from plant origin in the membrane of mammalian cells? Consequently, towards the long term goal of establishing a new modality of optical activation for application in neuroprosthetic devices, the aims of the present PhD project are the following:

- To determine the electric potential generated by PSI operating in open circuit configuration and embedded in a closed model membrane, in order to analyze the probability of activation of voltage-dependent ion channels.
- To determine the electric potential generated by PSI operating in closed circuit configuration and embedded in a closed model membrane, in order to analyze the probability of activation of voltage-dependent ion channels and compare this response with the response obtained with PSI in open circuit.
- To establish a methodology for delivery and detection of PSI in a mammalian cell model, in order to determine the feasibility of incorporation of the complexes.

1.5. Description of the project

The first study was designed to accomplish the first aim of the thesis. This is, to determine if the open circuit potential of PSI would be capable to induce a transmembrane potential difference when the complex is inserted in a membrane. In particular, the objective was to determine the conditions in terms of reaction center density and proximity to the voltage-dependent channels required for activation. Using a theoretical framework based on continuum electrostatics, the spatial distribution of the electric potential around a single reaction center embedded in a lipid vesicle was obtained under different conditions. This study is presented in the second chapter of the present thesis.

The main conclusion of the first study was that in physiologic conditions, it would be necessary to surround a voltage-activated ion channel with several reaction centers in order to increase the probability of causing a light-mediated channel opening. Then, the second study was aimed to evaluate the closed circuit response of PSI and to assess if this would be a better approach to modify the transmembrane potential. Using PSI complexes reconstituted in lipid vesicles, the light-induced proton movements were recorded and the kinetics of transmembrane ion movement and electric potential was studied using a computational model. This study is described in the third chapter of the present thesis.

The results of the second study suggested that in order to get a faster light-induced response, PSI would have to be used in open circuit configuration, where it was found that certain spatial conditions are required. Then, the second aim of the thesis was addressed, to determine if the complexes delivered to cells using liposomes are in fact incorporated in the membrane and, if incorporated, to determine their orientation and spatial distribution. Consequently, the third study was designed to establish methods to deliver and detect the localization and orientation of the complexes in the membrane of cells. This was done with the PSI proteoliposomes obtained in the second study and using an immuno-fluorescence technique to detect the presence of PSI in the cell membrane. As this study represents a step previous to the evaluation of light-induced responses, cells possessing voltage activated ion channels were used. This study is described in the chapter number four.

The results of the three studies of the present project are discussed in chapter number five. Additionally, the conclusions and future perspectives are also presented.

References

- [1] L.A. Geddes, A short history of the electrical stimulation of excitable tissue including electrotherapeutic applications, *Physiologist* 27 (1984) 5-47.
- [2] R.H. Pudenz, Neural stimulation: Clinical and laboratory experiences, *Surgical Neurology* 39 (1993) 235-242.
- [3] N. Bhadra & P.H. Peckham, Peripheral nerve stimulation for restoration of motor function, *Journal of Clinical Neurophysiology* 14 (1997) 378-393.
- [4] J.P. Reilly & J.P. Reilly, *Applied Bioelectricity : From Electrical Stimulation to Electropathology*, Springer, New York, 1998.
- [5] W.E. Finn & P.G. LoPresti, *Handbook of Neuroprosthetic Methods*, CRC Press, Boca Raton, 2003.
- [6] D. Chen, S.J. Fertig, N. Kleitman, R.L. Miller, E. Oliver, G.C.Y. Peng, N.L. Shinowara, M. Weinrich & J.J. Pancrazio, Advances in neural interfaces: report from the 2006 NIH Neural Interfaces Workshop, *Journal of Neural Engineering* 4 (2007) S137-S142.
- [7] P. Heiduschka & S. Thanos, Implantable bioelectronic interfaces for lost nerve functions, *Progress in Neurobiology* 55 (1998) 433-461.
- [8] J.P. Rauschecker & R.V. Shannon, Sending sound to the brain, *Science* 295 (2002).
- [9] N.D. Schiff, F. Plum & A.R. Rezai, Developing prosthetics to treat cognitive disabilities resulting from acquired brain injuries, *Neurological Research* 24 (2002) 116-124.
- [10] P.H. Peckham & J.S. Knutson, Functional electrical stimulation for neuromuscular applications, *Annual Review of Biomedical Engineering* 7 (2005) 327-360.
- [11] D.M. Durand, Electric stimulation of excitable tissue, in: J.D. Bronzino(ed.), *The Biomedical Engineering Handbook*, vol. I, CRC Press : IEEE Press, Boca Raton, 1995, .
- [12] M.R. Cohen & W.T. Newsome, What electrical microstimulation has revealed about the neural basis of cognition, *Current Opinion in Neurobiology*, 14 (2004) 169-177.
- [13] E.J. Tehovnik, Electrical stimulation of neural tissue to evoke behavioral responses, *Journal of Neuroscience Methods* 65 (1996) 1-17.
- [14] M.I. Hariz, Complications of deep brain stimulation surgery, *Movement Disorders* 17 (2002).

- [15] C.M. Gregory & C.S. Bickel, Recruitment patterns in human skeletal muscle during electrical stimulation, *Physical Therapy* 85 (2005) 358-364.
- [16] D. Palanker, A. Vankov, P. Huie, A. Butterwick, I. Chan, M.F. Marmor & M.S. Blumenkranz, High-Resolution Opto-Electronic Retinal Prosthesis: Physical Limitations and Design, *Artificial Sight*(2007) 255-277.
- [17] T. Hashimoto, C.M. Elder & J.L. Vitek, A template subtraction method for stimulus artifact removal in high-frequency deep brain stimulation, *Journal of Neuroscience Methods*, 113 (2002) 181-186.
- [18] G. Miesenböck & I.G. Kevrekidis, Optical imaging and control of genetically designated neurons in functioning circuits, *Annual Review of Neuroscience* 28 (2005) 533-563.
- [19] R.H. Kramer, J.J. Chambers & D. Trauner, Photochemical tools for remote control of ion channels in excitable cells, *Nature Chemical Biology* 1 (2005) 360-365.
- [20] J. Wells, C. Kao, E.D. Jansen, P. Konrad & A. Mahadevan-Jansen, Application of infrared light for in vivo neural stimulation, *Journal of Biomedical Optics* 10 (2005).
- [21] J. Wells, C. Kao, P. Konrad, T. Milner, J. Kim, A. Mahadevan-Jansen & E.D. Jansen, Biophysical mechanisms of transient optical stimulation of peripheral nerve, *Biophysical Journal* 93 (2007) 2567-2580.
- [22] J.W. Walker, J.A. McCray & G.P. Hess, Photolabile protecting groups for an acetylcholine receptor ligand. Synthesis and photochemistry of a new class of o-nitrobenzyl derivatives and their effects on receptor function, *Biochemistry* 25 (1986) 1799-1805.
- [23] E.M. Callaway & L.C. Katz, Photostimulation using caged glutamate reveals functional circuitry in living brain slices, *Proceedings of the National Academy of Sciences of the United States of America* 90 (1993) 7661-7665.
- [24] R. Wieboldt, K.R. Gee, L. Niu, D. Ramesh, B.K. Carpenter & G.P. Hess, Photolabile precursors of glutamate: Synthesis, photochemical properties, and activation of glutamate receptors on a microsecond time scale, *Proceedings of the National Academy of Sciences of the United States of America* 91 (1994) 8752-8756.
- [25] B.V. Zemelman, N. Nesnas, G.A. Lee & G. Miesenböck, Photochemical gating of heterologous ion channels: Remote control over genetically designated populations of neurons, *Proceedings of the National Academy of Sciences of the United States of America* 100 (2003) 1352-1357.

- [26] J.M. Nerbonne, Caged compounds: Tools for illuminating neuronal responses and connections, *Current Opinion in Neurobiology* 6 (1996) 379-386.
- [27] G.C.R. Ellis-Davies, Caged compounds: Photorelease technology for control of cellular chemistry and physiology, *Nature Methods* 4 (2007) 619-628.
- [28] Z. Melyan, E.E. Tarttelin, J. Bellingham, R.J. Lucas & M.W. Hankins, Addition of human melanopsin renders mammalian cells photoresponsive, *Nature* 433 (2005) 741-745.
- [29] G. Nagel, T. Szellas, W. Huhn, S. Kateriya, N. Adeishvili, P. Berthold, D. Ollig, P. Hegemann & E. Bamberg, Channelrhodopsin-2, a directly light-gated cation-selective membrane channel, *Proceedings of the National Academy of Sciences of the United States of America* 100 (2003) 13940-13945.
- [30] X. Li, D.V. Gutierrez, M.G. Hanson, J. Han, M.D. Mark, H. Chiel, P. Hegemann, L.T. Landmesser & S. Herlitze, Fast noninvasive activation and inhibition of neural and network activity by vertebrate rhodopsin and green algae channelrhodopsin, *Proceedings of the National Academy of Sciences of the United States of America* 102 (2005) 17816-17821.
- [31] E.S. Boyden, F. Zhang, E. Bamberg, G. Nagel & K. Deisseroth, Millisecond-timescale, genetically targeted optical control of neural activity, *Nat. Neurosci.* 8 (2005) 1263-1268.
- [32] F. Zhang, L. Wang, M. Brauner, J.F. Liawald, K. Kay, N. Watzke, P.G. Wood, E. Bamberg, G. Nagel, A. Gottschalk & K. Deisseroth, Multimodal fast optical interrogation of neural circuitry, *Nature* 446 (2007) 633-639.
- [33] M. Banghart, K. Borges, E. Isacoff, D. Trauner & R.H. Kramer, Light-activated ion channels for remote control of neuronal firing, *Nature Neuroscience* 7 (2004) 1381-1386.
- [34] M. Volgraf, P. Gorostiza, R. Numano, R.H. Kramer, E.Y. Isacoff & D. Trauner, Allosteric control of an ionotropic glutamate receptor with an optical switch, *Nature Chemical Biology* 2 (2006) 47-52.
- [35] F. Zhang, A.M. Aravanis, A. Adamantidis, L. De Lecea & K. Deisseroth, Circuit-breakers: Optical technologies for probing neural signals and systems, *Nature Reviews Neuroscience* 8 (2007) 577-581.
- [36] P. Gorostiza & E. Isacoff, Optical switches and triggers for the manipulation of ion channels and pores, *Molecular BioSystems* 3 (2007) 686-704.

- [37] D.L. Fortin, M.R. Banghart, T.W. Dunn, K. Borges, D.A. Wagenaar, Q. Gaudry, M.H. Karakossian, T.S. Otis, W.B. Kristan, D. Trauner & R.H. Kramer, Photochemical control of endogenous ion channels and cellular excitability, *Nature Methods* 5 (2008) 331-338.
- [38] P. Jordan, P. Fromme, H.T. Witt, O. Klukas, W. Saenger & N. Krauß, Three-dimensional structure of cyanobacterial photosystem I at 2.5 Å resolution, *Nature* 411 (2001) 909-917.
- [39] A. Ben-Shem, F. Frolow & N. Nelson, Crystal structure of plant photosystem I, *Nature* 426 (2003) 630-635.
- [40] P.E. Jensen, R. Bassi, E.J. Boekema, J.P. Dekker, S. Jansson, D. Leister, C. Robinson & H.V. Scheller, Structure, function and regulation of plant photosystem I, *Biochimica Et Biophysica Acta - Bioenergetics* 1767 (2007) 335-352.
- [41] P.R. Chitnis, Photosystem I: Function and physiology, *Annu. Rev. Plant Physiol. Plant Mol. Biol.* 52 (2001) 593-626.
- [42] I. Lee, J.W. Lee, A. Stubna & E. Greenbaum, Measurement of electrostatic potentials above oriented single photosynthetic reaction centers, *J. Phys. Chem. B* 104 (2000) 2439-2443.
- [43] H.-. Trissl, W. Leibl, J. Deprez, A. Dobek & J. Breton, Trapping and annihilation in the antenna system of Photosystem I, *Biochimica Et Biophysica Acta - Bioenergetics* 893 (1987) 320-332.
- [44] W. Leibl, B. Toupance & J. Breton, Photoelectric characterization of forward electron transfer to iron-sulfur centers in photosystem I, *Biochem.* 34 (1995) 10237-10244.
- [45] K. Sigfridsson, O. Hansson & P. Brzezinski, Electrogenic Light Reactions in Photosystem .I. Resolution of Electron-Transfer Rates Between the Iron-Sulfur Centers, *Proc. Natl. Acad. Sci. U.S.A.* 92 (1995) 3458-3462.
- [46] E. Govorunova, A. Dér, R. Tóth-Boconádi & L. Keszthelyi, Photosynthetic charge separation in oriented membrane fragments immobilized in gel, *Bioelectrochemistry and Bioenergetics*, 38 (1995) 53-56.
- [47] K.N. Gourovskaya, M.D. Mamedov, I.R. Vassiliev, J.H. Golbeck & A.Y. Semenov, Electrogenic reduction of the primary electron donor P700(+) in photosystem I by redox dyes, *FEBS Lett.* 414 (1997) 193-196.

- [48] E.L. Barsky, Z. Dancshazy, L.A. Drachey, M.D. Il'ina, A.A. Jasaitis, A.A. Kondrashin, V.D. Samuilov & V.P. Skulachev, Reconstitution of biological molecular generators of electric current. Bacteriochlorophyll and plant chlorophyll complexes, *J.Biol.Chem.* 251 (1976) 7066-7071.
- [49] G. Orlich & G. Hauska, Reconstitution of Photosynthetic Energy-Conservation .1. Proton Movements in Liposomes Containing Reaction Center of Photosystem-I from Spinach-Chloroplasts, *Eur. J. Biochem.* 111 (1980) 525-533.
- [50] J. Cladera, J.L. Rigaud, H. Bottin & M. Dunach, Functional reconstitution of photosystem I reaction center from cyanobacterium *Synechocystis* sp PCC6803 into liposomes using a new reconstitution procedure, *J. Bioenerg. Biomembr.* 28 (1996) 503-515.
- [51] J.F. Millsaps, B.D. Bruce, J.W. Lee & E. Greenbaum, Nanoscale photosynthesis: Photocatalytic production of hydrogen by platinized photosystem I reaction centers, *Photochemistry and Photobiology* 73 (2001) 630-635.
- [52] I. Lee, J.W. Lee & E. Greenbaum, Biomolecular electronics: Vectorial arrays of photosynthetic reaction centers, *Phys. Rev. Lett.* 79 (1997) 3294-3297.
- [53] B. Munge, S.K. Das, R. Ilagan, Z. Pendon, J. Yang, H.A. Frank & J.F. Rusling, Electron Transfer Reactions of Redox Cofactors in Spinach Photosystem I Reaction Center Protein in Lipid Films on Electrodes, *J. Am. Chem. Soc.* 125 (2003) 12457-12463.
- [54] R. Das, P.J. Kiley, M. Segal, J. Norville, A.A. Yu, L.Y. Wang, S.A. Trammell, L.E. Reddick, R. Kumar, F. Stellacci, N. Lebedev, J. Schnur, B.D. Bruce, S.G. Zhang & M. Baldo, Integration of photosynthetic protein molecular complexes in solid-state electronic devices, *Nano Lett.* 4 (2004) 1079-1083.
- [55] H. O'Neill & E. Greenbaum, Spectroscopy and Photochemistry of Spinach Photosystem I Entrapped and Stabilized in a Hybrid Organosilicate Glass, *Chem. Mater.* 17 (2005) 2654-2661.
- [56] L. Frolov, Y. Rosenwaks, C. Carmeli & I. Carmeli, Fabrication of a photoelectronic device by direct chemical binding of the photosynthetic reaction center protein to metal surfaces, *Adv. Mater.* 17 (2005) 2434-2437.
- [57] E. Greenbaum, M. Humayun, T. Kuritz, J.W. Lee, C.A. Sanders, B. Bruce, J. Millsaps & I. Lee, Application of photosynthesis to artificial sight, *Proc. Annu. Int. Conf. IEEE EMBS* 4 (2001) 4089-4091.

[58] T. Kuritz, I. Lee, E.T. Owens, M. Humayun & E. Greenbaum, Molecular photovoltaics and the photoactivation of mammalian cells, *IEEE Trans. Nanobiosci.* 4 (2005) 196-200.

2. Spatial Distribution of the Electric Potential from Photosystem I Reaction Centers in Lipid Vesicles

Pennisi, CP; Greenbaum, E; Yoshida, K.

Published in IEEE Transactions on NanoBioscience, 7 (2), pp. 164-171 (2008).

DOI 10.1109/TNB.2008.2000748

3. Analysis of Light Induced Transmembrane Ion Gradients and Membrane Potential in Photosystem I Proteoliposomes

Pennisi, C.P.; Greenbaum, E.; Yoshida K.
Submitted for publication to Biophysical Chemistry (2008).

4. Incorporation of Photosynthetic Reaction Centers in the Membrane of Human Cells: Toward a New Tool for Optical Control of Cell Activity

Pennisi, C.P.; Jensen, P.E.; Zachar, V.; Greenbaum, E.; Yoshida, K.
Accepted for publication in Cellular and Molecular Bioengineering (2008)
DOI 10.1007/s12195-008-0040-8

5. General discussion

5.1. Introduction

The present project was conceived with the goal of establishing an alternative method to the conventional electrical stimulation for application in neuroprosthetic devices. In particular, the series of studies reported above as part of this thesis were aimed to investigate the possibility of using Photosystem I reaction centers in the optical activation of excitable cells. In this section, the main results will be discussed in terms of the specific aims defined at the beginning of the project. In addition, some methodological aspects of the performed studies will be described. Finally, future perspectives and conclusions will be presented at the end of the chapter.

5.2. Discussion of the main results

5.2.1. Charge separation potential as source of cell activation

The first aim of this thesis was to determine if the open circuit potential measured from isolated PSI reaction centers [1] could be translated into a transmembrane potential capable of activation of voltage-dependent ion channels in a realistic aqueous ionic environment, as it was previously suggested by Greenbaum et al. [2]. The original measurements by Lee et al. were performed on isolated reaction centers supported on a metal film and in vacuum. Being in vacuum, there was no interaction with dielectric materials or unbound ionic species. Therefore, these results could not be extrapolated to the case when the reaction centers are inserted in the membrane of a cell. This particular issue had not been previously directly addressed in the literature, although there was enough information to treat it from a theoretical point of view using continuum electrostatics (see section 2.4, study I, and section 5.3.2 for a further discussion on the methodology). Therefore, in a computational model of a vesicle with uniform distribution of PSI was developed (study I), which was used to calculate the electric potential distribution around a single PSI under different conditions. The results of this study showed that when the vesicle was simulated in a non-electrolytic environment (for instance, pure water), PSI can develop a transmembrane potential in response to continuous illumination (see Fig. 2a, study I). The magnitude of this potential difference increases linearly with the reaction center density (see Fig. 6, study I). The values obtained with the model in water are in agreement with those obtained with the formula proposed by Junge [3] and also with measurements obtained from PSI proteoliposomes in response to flash stimulation [4]. However, the formula cannot be used to determine the response to continuous light stimulation under normal physiological conditions. In this case, the membrane is surrounded by electrolytes. When this case was simulated, the cloud of mobile charges close to the membrane acted as a screen around the light-induced separated charges. As consequence, the localized charges that initially energized the membrane are rapidly redistributed into the aqueous phases and the membrane potential approaches to zero (see Fig.

2b, study I). The time constant of this redistribution process is inversely proportional to the ionic concentration of the electrolyte [5]. For an electrolyte concentration of 0.1 M, normally found in a physiological solution, the membrane remains energized for a few nanoseconds. Then, the potential distribution in space redistributes and becomes confined only to the membrane in close proximity to the reaction center. The maximum potential difference was obtained between the separated charges and its magnitude was about 1.3 V. This value is consistent with the measurements done in vacuum [1] and was almost independent of the ionic strength of the electrolytes. However, the potential decays rapidly as the a function inversely related to the distance to the reaction center (see Fig. 5, study I).

The current model of voltage gating states that a transmembrane potential difference, developing an electric field close to a voltage-dependent ion channel, moves a number of equivalent gating charges across the membrane. This event causes a conformational movement in a channel subunit that opens the channel gate and can be recorded as a low magnitude current that lasts for 1-2 ms [6]. In addition, the channel open probability is related to the magnitude of the electric potential by a sigmoidal function. This means that there is a threshold over which small potential increases cause large increases in the channel open probability [7]. Under normal physiological conditions, the charge separation potential generated by PSI in open circuit configuration cannot sustain a transmembrane potential for more than a few nanoseconds. Therefore it would not be possible to activate the channels if the reaction centers are, as in the model vesicle, evenly distributed over the surface of the cell. However, according to the potential distribution expected under normal ionic concentration (Fig 2.b, study I), an electric potential of about 10 mV could be found a lateral distance of 3-4 nm from the complex. This indicates that an option to increase the probability of driving a channel to the open state is to localize several PSI reaction centers close to the channel. Therefore, targeting of the PSI liposomes to the voltage gated channels is necessary.

5.2.2. Analysis of the closed circuit response

The second aim of this work was to determine whether the potential difference generated by PSI in closed circuit configuration could be used as “driving force” for the voltage-dependent channels, as previously suggested by Greenbaum et al. [2]. In contrast to the open circuit configuration, where there is only a transient displacement current, in this operational mode PSI performs a cyclic transfer of charge which is coupled to a transmembrane ion current [8]. As in the first study of the present work, the second study was based on vesicles having reconstituted PSIs, although in this case a combined experimental and computational approach was used (see section 3.4, study II, for a further discussion on the methodology). In the first part of the second study, a reconstitution procedure was implemented that resulted in proteoliposomes preserving the structure and function of the PSI reaction centers (see study II, section 3.1). In the second part, a computational model was developed and its parameters adjusted to fit the measured light-induced responses in the first part (see study II, section 3.2). When vesicles are

illuminated in presence of phenazine methosulfate, this redox carrier causes cyclic electron transfer around PSI and mediates proton influx into the vesicles (see Fig. 1, study II). As the intravesicular concentration of protons increases, there is a concomitant increase in the transmembrane potential. This proton electrochemical potential difference stimulates the efflux of protons and the movement of counter ions (K^+ and Cl^-) by passive diffusion. After influx and passive diffusion reach the equilibrium, a steady state proton gradient is established. When the light is turned off, there is a re-equilibration of the ionic concentrations due to passive diffusion. This process can be interpreted as a single pump and leak mechanism [9]. The time- and light-dependent proton activity can be characterized by the rates of proton influx/efflux and by the maximum obtainable proton gradient in steady state.

The proton transport activities observed from the models in study II (see Figs. 4 & 5, study II) were consistent to those previously recorded from proteoliposomes prepared using the same methodology [10]. But a lower rate of proton pumping and a lower pH gradient in steady state were obtained in this study. According to the simulation results, these differences are related to lower incorporation efficiency and are attributable to a lower number of PSIs mediating proton pumping inside the vesicles. The rate of proton translocation can be increased by using the ionophore valinomycin (see Fig. 5, study II). It was found that this ionophore increases the membrane permeability to potassium and protons, decreasing the backpressure of the electric potential. Then, its effect on rate of proton pumping and the pH gradient is equivalent to an increase in the number of pumps. The model allowed the calculation of the magnitude of the ionic currents and electric potential associated with proton transport (see Fig 9, study II). The steady state value of membrane potential was about 200 mV, which is comparable to the 180 mV value measured in proteoliposomes prepared with reaction centers from purple bacteria [11] and to the 200 to 300 mV membrane potential of proton gradients that drive ATP synthesis in the thylakoids [8]. It was found that the kinetics of counter ion movement affect the proton transport, mainly by alteration of the membrane potential (see Fig 10, study II). Thus, when the counter ion movement is minimized, the steady state membrane potential is increased.

The responses obtained from PSI proteoliposomes in the second study can be used to evaluate the possibility of activation of voltage-dependent ion channels in the closed circuit configuration. In principle, although the maximum potential that would be possible to develop exceeds the magnitude necessary to trigger cell activation, the kinetics of the process is quite slow: the time constants of the on and off processes are in the range of 2-3 minutes. An appropriate synaptically generated trigger signal for a voltage activated channel has an on and off rate on the order of milliseconds. According to the described model, the rate of change of the potential can be increased by increasing the number of reaction centers and by minimizing the counter ion movement. However, the rate of proton influx is limited by the maximum turnover rate (k_{max} defined in section 3.2.1, study II). In the average vesicle, for the reported reconstitution density and in basal conditions, the maximum turnover rate was 28 s^{-1} . This parameter

depends mostly on the rate of diffusion of the double-protonated species PMSH_2 across the membrane, as the charge-separation process in PSI takes less than $1 \mu\text{s}$ [12] and the transfer of charge from PSI is efficiently mediated by phenazine methosulfate (the rate constant is approx. 150 s^{-1}) [13]. Therefore, unless a more efficient way to carry the protons across the membrane is found, this method is not appropriate for providing fast triggering of ion channels.

5.2.3. Comparison of the alternatives

The computational models of PSIs inserted in a membrane that were presented in the first two studies were simulated in conditions of continuous (study I) or long lasting ($t=250 \text{ s}$) light stimulation (study II). The responses obtained on each of these situations can be compared to analyze the characteristics of the expected electric potential across the membrane of the vesicle. According to study I, in open circuit there is only a transient membrane depolarization, which is associated with the displacement current caused by charge separation. After this transient, a potential difference of about 10 mV remains confined to the membrane in close proximity to the reaction center. The on and off rates of this charge separation process, for PSI reconstituted in vesicles and operating in open circuit, are reported in the literature. The potential establishes in less than 200 ns [4], while the charges recombine in approximately 100 ms [4;12]. On the other hand, according to study II, in closed circuit the membrane potential reaches a steady value. Depending on the PSI density and counter ion permeability this potential could reach approximately 200 mV , but the onset time is in the order of minutes. In this case, this behavior is associated with the ionic current caused by proton translocation. In addition, when the light is turned off, the potential difference also dissipates with a time constant in the order of minutes. From the above, it is evident that the open-circuit configuration seems to be the most appropriate option for providing the fast trigger signal necessary to activate the voltage-dependent channels.

5.2.4. Incorporation of PSI in cells

The PSI reaction centers are pigment-protein complexes that are found in membranes of bacterial or plant origin. There was only one previous report of incorporation of PSI in the membrane of mammalian cells [14]. Although PSI was delivered with proteoliposomes whose lipid formulations are known to be incorporated by human and murine cells, there was no direct evidence of the incorporation. The third study of the present thesis was aimed to establish a methodology for the delivery and the detection of PSI in membranes, in order to evaluate the occurrence and the nature of the incorporation process. In addition, the study was aimed to provide information about localization and orientation of the reaction centers in the cell membrane. The detection methods were based on the use of separate fluorescent markers for the intravesicular contents and for the PSI reaction centers (see section 4.4, study III, for a further discussion of the methodology). The method used to evaluate the occurrence of liposome-cell interaction allowed identifying that at least part of the vesicles fused with the membrane of

the cells, although some others followed the endocytic pathway (see Fig. 1, study III). These results are consistent with previous reports of delivery of lipid vesicles to cells [15]. Treatment of cells with proteoliposomes could induce adverse effects, including membrane damage [16] and cell death [14]. In this case, assessment of cell viability revealed that the cells were not significantly damaged after treatment with the proteoliposomes. The PSI complexes were detected in the membrane of the cells by immunofluorescence, which also confirmed the occurrence of liposome-membrane fusion (see Fig. 4, study III). Vesicle adsorption, as it was observed in by others in similar experiments [17], was ruled out because the fluorescent signals from vesicular contents and PSI were not colocalized. The nature of the primary antibody (anti-PsaD), which binds to a stromal (externally located) subunit of the complex, allowed detecting the orientation of the PSIs in the membrane. Therefore, the fluorescent image corresponding to the marker of this antibody shows only those incorporated PSI complexes that are oriented with its right-side out (see Fig. 4, study III). PSI can be visualized as randomly distributed clusters in the membrane of the ASC cells. A similar distribution has been observed in erythrocytes treated with cytochrome-oxidase proteoliposomes, where the proteins clustered in the cell membrane [18]. This might be consequence of the self-aggregation property of the PSI reaction centers, but a picture of which is the distribution of the inside-out oriented complexes is necessary to extract further conclusions.

In summary, the results of this study indicated that it is possible to incorporate PSI reaction centers in the membrane of mammalian cells using proteoliposomes. The incorporation process does not damage the cells and the complexes could be clustered in the right-side-out orientation to test the activation of voltage-dependent ion channels.

5.3. Methodological considerations

5.3.1. Methodological design of the project

The idea behind the methodological design of this project was to address the question of activation of excitable cells using PSI with approaches of increasing complexity. Initially, the open and closed circuit responses of PSI were studied in lipid vesicles, which are models widely used in theoretical and experimental studies of lipid-protein interaction [19-22]. The original idea was to start the studies in small vesicles (diameter ranging from 0.1 to 1 μm), then to make a transition to giant vesicles (diameter ranging from 10 to 100 μm) and finally to evaluate the responses in cells having voltage-dependent channels. The study in giant vesicles was initiated during the course of the project in order to obtain a more direct measurement of some variables (like for instance, the membrane potential). However, due to difficulties in the manipulation and attachment of the vesicles that have hindered the measurements, this study was discontinued. Then, the project was based on the studies on small vesicles and cells.

5.3.2. Theoretical models

The studies I and II have in common the computational simulation of a model lipid vesicle having PSI inserted in the membrane. The idea was to obtain the open and closed circuit responses of PSI when the complex is inserted in the membrane of a cell-like compartment and is excited with pulses of light.

The first study addressed the open circuit problem using continuum electrostatics (Poisson-Boltzmann theory). This theory has been previously used to obtain descriptions of charge distributions around dielectric membranes in electrolytes [23]. It was also applied to describe the light-induced charge separation process in the pigment bacteriorhodopsin inserted in a lipid membrane [24;25]. Although a picture of the potential distribution in a plane perpendicular to the membrane was provided, the light-separated charge was considered to be uniformly distributed over the membrane surface and so, there was no information about the spatial distribution of the electric potential around single charges. In order to obtain this information, discrete charges were used in the present study. Besides, non-homogeneous dielectric constants a closed membrane (vesicle) was considered instead of a parallel membrane. Because the membrane thickness is several orders of magnitude smaller than the vesicle radius, it is generally assumed that closed vesicles can be modeled with two finite and identical parallel domains separated by a membrane [26]. That approximation is only valid for concentrated electrolytes and would not have shown charging of the vesicle interior in water, as predicted by the model of this study.

The second study addressed the closed circuit responses using a two-compartment model, whose basic behavior could be predicted by combining the Goldman-Hodging-Katz current equation [7] and the Fick's law of diffusion across membranes. This approach has been applied to obtain very accurate descriptions the responses of vesicles having ATP-driven proton pumps [27-30]. The results provided by the model of the present study could be fitted quite accurately to the measured responses. Therefore the use of a more elaborated theoretical approach, like for instance that based on irreversible thermodynamics [11;31;32], was not justified for the scope of this study.

In both studies, the validity of the models was assessed by comparing the results with data from previous studies performed by others. Only in study number II, the measurements of proton gradients in PSI proteoliposomes were used to adjust the parameters of the model. Therefore, it is important to notice that the estimations of the electric potential in both studies represent theoretical expected values for PSIs reconstituted in a lipid vesicle. In order to complete the validation process, further experiments should be performed to measure the electric potential in both configurations.

5.3.3. Experimental model

At the beginning of the project, it was necessary to select a suitable cell model for evaluation of PSI incorporation, which could also be useful to test the hypothesis of light activation of voltage-dependent channels. Various excitable cells appropriate for electrical recordings using glass micropipettes

(patch-clamp) were considered. Before the first study was concluded, a series of pilot experiments were performed. In these studies, isolated skeletal muscle cells, which were acutely dissociated from rat muscles, were used. In brief, the cells were incubated with PSI proteoliposomes according to the protocol described by Kuritz et. al. [14] and then evaluated for light-induced electrical and/or mechanical responses. The results from this first “blind” approach used to test the hypothesis of cell activation were negative. However, the practical problems encountered in these experiments were useful for the design of the further experimental procedures. In particular, it was found that the viability of acutely dissociated muscle cells decreases very rapidly. Besides, the cells are very difficult to keep in culture, because they start to de-differentiate after few days [33]. In addition, muscle cells have a complex membrane structure that might have caused difficulties in the incorporation study and also a great variety of membrane receptors and channels that would have perturbed testing the hypothesis of cell activation. Then, a reasonable alternative for the experimental model were the mesenchymal stem cells (MSCs). Although these cells are not excitable, they have a relative small size, a rather simple morphology and possess a group of voltage-gated potassium channels with a well described electrophysiological behavior [34-36].

5.3.4. Reconstitution procedure

The procedure used to prepare the PSI proteoliposomes used in studies II and III involved sonication of a lipid suspension in buffer, which is a widely used method to produce small unilamellar vesicles due to its inherent simplicity. Then, the PSI reaction centers were incorporated into these preformed vesicles also using sonication, method which has previously shown to produce functionally active PSI proteoliposomes [10;12]. An additional step of incubation with adsorbent beads to remove any residual detergent was performed in study II and a gel filtration step to remove residual detergent and the non incorporated fluorescent dye pyranine was performed in study III.

As it was reported in study II, an issue when producing proteoliposomes by sonication is that it is not possible to control the final orientation of the proteins in the membrane. This issue was reported as one of the causes of a low proton pumping efficiency (study II) and might have influenced the final orientation of the PSI complexes in the membrane of the cells (study III). It was shown that an alternative method to control the final orientation of membrane proteins is the detergent mediated reconstitution [37]. Therefore, production of proteoliposomes with this method was attempted in the present project, according to the protocol of Cladera et. al for reconstitution of cyanobacterial PSI in liposomes [9]. Several conditions were adjusted in the protocol, like for instance the lipid to chlorophyll ratio, the detergent to lipid ratio, the detergent type and the reaction center origin (PSIs from spinach, *Arabidopsis* and *Synechocystis* were used). However, it was never possible to obtain the same degree of structural and functional integrity in the vesicles as the one obtained using the sonication procedure.

5.4. Perspectives

In a general sense, bionanotechnology is an emerging scientific field that involves the application of molecules of biological origin, with properties of nanoscale-sized machines, to problems where the conventional ‘top-down’ approaches are reaching a limit. The application of the Photosystem I to the problem of optical activation of cells represents an effort in such direction, which could result in an alternative exceeding the capabilities of the currently established electrical stimulation methods.

According to the results of the present project, several optimization strategies can be recommended for the future research efforts aiming for optical activation of cells using PSI. The first issue that has to be addressed in future experiments is to determine the correct functional insertion of PSI in the membrane of mammalian cells. In principle, an appropriate technique to measure PSI function should be found. As it was mentioned before, electrophysiological techniques could be used to assess the responses of the treated cells to light, as for instance electrical recordings with intracellular microelectrodes or patch-clamp pipettes. However, these experiments can only provide information about the effects caused by PSI and are not useful for analyzing the functional capabilities of the complexes. A possible alternative is then the use of fluorescent indicators of pH, as in study II, to monitor the development of light induced proton gradients across the membrane of the cells. Another useful pH indicator is pyranine, which was already used in study II to detect cell-liposome interactions.

After evaluation of PSI function, the research strategies must be focused on the issues of localization and orientation of the reaction centers in the membrane of the targeted cells. The complexes could be localized in specific membrane areas where a focal depolarization can propagate to adjacent areas and activate the whole cell. One possible way to test this concept could be to deliver the complexes to a membrane region restricted by a wide-bored glass pipette. Additionally, the pipette could be used to focally monitor the extracellular potential [38] and also as a light guide to deliver the stimulation pulses [39]. Another advantage of this method is that the insertion of the vesicles and the orientation of the complexes could be electrically controlled through the pipette [40]. Another possible approach to address the problem of localization could be the use immunohistochemistry techniques to target immuno-labeled PSI proteoliposomes to specific areas on the surface of the cells. These could be areas rich in receptors, like for instance the endplate of muscle cells or the postsynaptic terminals in neurons.

Even though the closed circuit configuration has been discarded as a methodology to elicit fast cellular responses, there are still applications that could exploit this possibility of optical control of transmembrane pH and potential. For instance, this configuration might be used to modulate cell activity by causing sub-threshold membrane depolarization or hyperpolarization. This principle, in a shorter time scale, is used by the approaches of photosensitization of potassium channels that were described in the introductory section. This configuration also represents an interesting tool that could be applied in the

study of mechanisms dependent on pH, like for example, the recently discovered of proton-gated ion channels from neurons, that seem to be involved in mechanisms of nociception [41]. It is important to notice that the final orientation of the complexes is an issue that also has to be considered in these applications. It should also be noticed that PSI is not naturally optimized to work as a proton pump and it would be necessary to evaluate if it is simpler and more efficient to use other molecular structures like Photosystem II reaction centers or bacteriorhodopsin for such purpose.

The results of the present project should not be limited to the area of optical activation of excitable cells. As it was mentioned in the discussion of studies I and II, the computational models could be adapted to other relevant problems in biological as well non-biological areas of application of PSI reaction centers. These applications include, for instance, the potential use of PSI liposomes in the photoconversion layer of photovoltaic cells or biosensors [42-44].

Finally, the hypothesis of using PSI reaction centers for the optical activation of excitable cells is still an open question. Fundamental issues like efficiency in the short term and stability in the long term should be resolved before the method could be considered as a concrete alternative for application in the field of neuroprosthesis. Although other effective optical activation methods are readily available, electrical stimulation methods will be still the most used methodology for the activation of excitable cells in the clinical practice in the years to come. Perhaps there will be a period of transition, in which hybrid systems will introduce some of the principles of optical methods. An example of such a system, would be the microchannel glass electrode array used for high resolution retinal stimulation [45] taking advantage of a high density photosensitive layer based on immobilized PSI reaction centers [46].

5.5. Conclusions

The research studies presented in this thesis have contributed with new theoretical descriptions and experimental data regarding the possible use of Photosystem I reaction centers for optical activation of excitable cells. This information helped achieving the aims stated at the beginning of the project. In particular, the simulation studies (studies I and II) have delimited the use of PSI for fast cell activation to the open circuit configuration, where certain conditions would be required for activation of the voltage-dependent ion channels. Besides, new methods were also provided (study III), which allowed determining the feasibility of PSI incorporation in the membrane of mammalian cells. Therefore, it can be concluded that the initial aims described at the beginning of the present project were achieved to a great extent. These results should be considered as a platform for future research efforts aimed to determine the concrete applicability of PSI reaction centers in the optical activation of excitable cells.

References

- [1] I. Lee, J.W. Lee, A. Stubna & E. Greenbaum, Measurement of electrostatic potentials above oriented single photosynthetic reaction centers, *J. Phys. Chem. B* 104 (2000) 2439-2443.
- [2] E. Greenbaum, M. Humayun, T. Kuritz, J.W. Lee, C.A. Sanders, B. Bruce, J. Millsaps & I. Lee, Application of photosynthesis to artificial sight, *Proc. Annu. Int. Conf. IEEE EMBS* 4 (2001) 4089-4091.
- [3] W. Junge, Membrane Potentials in Photosynthesis, *Annual Review of Plant Physiology* 28 (1977) 503-536.
- [4] M.D. Mamedov, A.A. Mamedova, S.K. Chamorovsky & A.Y. Semenov, Electrogenic reduction of the primary electron donor P700 by plastocyanin in photosystem I complexes, *FEBS Lett.* 500 (2001) 172-176.
- [5] Kleijn J.M. & van Leeuwen H.P., Electrostatic and electrodynamic properties of biological interfaces, in: A. Baszkin and W. Norde(eds.), *Physical Chemistry of Biological Interfaces*, Marcel Dekker, New York - Basel, 2000, pp. 49-84.
- [6] F. Bezanilla, Voltage-gated ion channels, *IEEE Transactions on Nanobioscience* 4 (2005) 34-48.
- [7] B. Hille, *Ion Channels of Excitable Membranes*, Sinauer Associates Inc, Sunderland, USA, 2001.
- [8] B. Ke, Proton translocation and ATP synthesis, in: B. Ke(ed.), *Photosynthesis - Photobiochemistry and Photobiophysics*, Kluwer, Dordrecht, 2001, .
- [9] J. Cladera, J.L. Rigaud, H. Bottin & M. Dunach, Functional reconstitution of photosystem I reaction center from cyanobacterium *Synechocystis* sp PCC6803 into liposomes using a new reconstitution procedure, *J. Bioenerg. Biomembr.* 28 (1996) 503-515.
- [10] G. Orlich & G. Hauska, Reconstitution of Photosynthetic Energy-Conservation .1. Proton Movements in Liposomes Containing Reaction Center of Photosystem-I from Spinach-Chloroplasts, *Eur. J. Biochem.* 111 (1980) 525-533.
- [11] D. Molenaar, W. Crielaard & K.J. Hellingwerf, Characterization of protonmotive force generation in liposomes reconstituted from phosphatidylethanolamine, reaction centers with light-harvesting complexes isolated from *Rhodospseudomonas palustris*, *Biochem.* 27 (1988) 2014-2023.

- [12] K. Sigfridsson, O. Hansson & P. Brzezinski, Electrogenic Light Reactions in Photosystem .I. Resolution of Electron-Transfer Rates Between the Iron-Sulfur Centers, *Proc. Natl. Acad. Sci. U.S.A.* 92 (1995) 3458-3462.
- [13] K.N. Gourovskaya, M.D. Mamedov, I.R. Vassiliev, J.H. Golbeck & A.Y. Semenov, Electrogenic reduction of the primary electron donor P700(+) in photosystem I by redox dyes, *FEBS Lett.* 414 (1997) 193-196.
- [14] T. Kuritz, I. Lee, E.T. Owens, M. Humayun & E. Greenbaum, Molecular photovoltaics and the photoactivation of mammalian cells, *IEEE Trans. Nanobiosci.* 4 (2005) 196-200.
- [15] C.-. Chu, J. Dijkstra, M.-. Lai, K. Hong & F.C. Szoka, Efficiency of cytoplasmic delivery by pH-sensitive liposomes to cells in culture, *Pharm. Res.* 7 (1990) 824-834.
- [16] G.D. Eytan & E. Eytan, Fusion of proteoliposomes and cells. ATP-dependent Ca²⁺ uptake into erythrocytes catalyzed by Ca²⁺-ATPase from skeletal muscle. *Journal of Biological Chemistry* 255 (1980) 4992-4995.
- [17] F. Szoka, K. Jacobson, Z. Derzko & D. Papahadjopoulos, Fluorescence studies on the mechanism of liposome-cell interactions in vitro, *Biochim.Biophys.Acta* 600 (1980) 1-18.
- [18] A.E. Gad, R. Broza & G.D. Eytan, Fusion of cells and proteoliposomes: Incorporation of beef heart cytochrome oxidase into rabbit erythrocytes, *FEBS Letters* 102 (1979) 230-234.
- [19] P.K.J. Kinnunen, A. Kõiv, J.Y.A. Lehtonen, M. Rytömaa & P. Mustonen, Lipid dynamics and peripheral interactions of proteins with membrane surfaces, *Chemistry and Physics of Lipids* 73 (1994) 181-207.
- [20] H.-. Döbereiner, Properties of giant vesicles, *Current Opinion in Colloid and Interface Science* 5 (2000) 256-263.
- [21] N. Düzgünes, L.A. Bagatolli, P. Meers, Y. Oh & R.M. Straubinger, Fluorescence methods in liposome research, in: V.P. Torchilin and V. Weissig(eds.), *Liposomes - A Practical Approach*, vol. 2, Oxford University Press, 2003, pp. 149-166.
- [22] M. Edidin, The state of lipid rafts: From model membranes to cells, *Annual Review of Biophysics and Biomolecular Structure* 32 (2003) 257-283.
- [23] V.B. Arakelian, D. Walther & E. Donath, Electric potential distributions around discrete charges in a dielectric membrane-electrolyte solution system, *Colloid & Polymer Science* 271 (1993) 268-276.

- [24] F.T. Hong, Mechanisms of Generation of Early Receptor Potential Revisited, *Bioelectrochem. Bioenerget.* 5 (1978) 425-455.
- [25] F.T.Hong,. Photovoltaic Effects in Biomembranes - Reverse-Engineering Naturally-Occurring Molecular Optoelectronic Devices, *IEEE Engineering in Medicine and Biology Magazine* 13 (1994) 75-93.
- [26] K.E. Forsten, R.E. Kozack, D.A. Lauffenburger & S. Subramaniam, Numerical-Solution of the Nonlinear Poisson-Boltzmann Equation for A Membrane-Electrolyte System, *J. Phys. Chem.* 98 (1994) 5580-5586.
- [27] A.B. Bennett & R.M. Spanswick, Optical measurements of ΔpH and ΔV in corn root membrane vesicles: Kinetic analysis of Cl^- effects on a proton-translocating ATPase, *J. Membr. Biol.* 71 (1983) 95-107.
- [28] D. Brauer, S. Tu, A. Hsu & C.E. Thomas, Kinetic Analysis of Proton Transport by the Vanadate-Sensitive ATPase from Maize Root Microsomes, *Plant Physiol.* 89 (1989) 464-471.
- [29] D.P. Briskin & I. Reynolds-Niesman, Determination of H^+/ATP stoichiometry for the plasma membrane H^+ -ATPase from red beet (*Beta vulgaris* L.) storage tissue, *Plant Physiol.* 95 (1991) 242-250.
- [30] M. Grabe & G. Oster, Regulation of organelle acidity, *J. Gen. Physiol.* 117 (2001) 329-343.
- [31] H.V. Westerhoff, B.J. Scholte & K.J. Hellingwerf, Bacteriorhodopsin in liposomes. I. A description using irreversible thermodynamics. *Biochim. Biophys. Acta* 547 (1979) 544-560.
- [32] K.J. Hellingwerf, J.C. Arents, B.J. Scholte & H.V. Westerhoff, Bacteriorhodopsin in liposomes. II. Experimental evidence in support of a theoretical model. *Biochim. Biophys. Acta* 547 (1979) 561-582.
- [33] A. Bekoff & W. Betz, Properties of Isolated Adult Rat Muscle-Fibers Maintained in Tissue-Culture, *Journal of Physiology-London* 271 (1977) 537-&.
- [34] J.F. Heubach, E.M. Graf, J. Leutheuser, M. Bock, B. Balana, I. Zahanich, T. Christ, S. Boxberger, E. Wettwer & U. Ravens, Electrophysiological properties of human mesenchymal stem cells, *Journal of Physiology* 554 (2004) 659-672.
- [35] G.-. Li, H. Sun, X. Deng & C.-. Lau, Characterization of ionic currents in human mesenchymal stem cells from bone marrow, *Stem Cells* 23 (2005) 371-382.

- [36] C.P. Pennisi, V. Zachar & K. Yoshida, Electrophysiological characterization of human mesenchymal stem cells derived from adipose tissue, *EMBO Conference Series - Advances in Stem Cell Research*(2007).
- [37] J.-. Rigaud, B. Pitard & D. Levy, Reconstitution of membrane proteins into liposomes: Application to energy-transducing membrane proteins, *Biochim. Biophys. Acta, Bioenerg.* 1231 (1995) 223-246.
- [38] C. Sevcencu, C.P. Pennisi, K. Yoshida & H. Gregersen, Simultaneous monitoring of cellular depolarization and contraction: A new method to investigate excitability and contractility in isolated smooth muscle cells, *American Journal of Physiology - Gastrointestinal and Liver Physiology* 294 (2008).
- [39] W. Stuhmer & W. Almers, Photobleaching through Glass Micropipettes: Sodium Channels without Lateral Mobility in the Sarcolemma of Frog Skeletal Muscle, *Proceedings of the National Academy of Sciences* 79 (1982) 946-950.
- [40] J.L. Rae & R.A. Levis, Single-cell electroporation, *Pflugers Archiv European Journal of Physiology* 443 (2002) 664-670.
- [41] D.A. De La Rosa, P. Zhang, D. Shao, F. White & C.M. Canessa, Functional implications of the localization and activity of acid-sensitive channels in rat peripheral nervous system, *Proceedings of the National Academy of Sciences of the United States of America* 99 (2002) 2326-2331.
- [42] S. Ajiki, H. Sugino, H. Toyotama, M. Hara & J. Miyake, Reconstitution and immobilization of photo-reaction units from photosynthetic bacterium *Rhodospseudomonas viridis*, *Mater. Sci. Eng., C* 6 (1998) 285-290.
- [43] K.B. Lam, E.A. Johnson, M. Chiao & L. Lin, A MEMS photosynthetic electrochemical cell powered by subcellular plant photosystems, *J. Microelectromech. Syst.* 15 (2006) 1243-1250.
- [44] Y. Lu, J. Xu, B. Liu & J. Kong, Photosynthetic reaction center functionalized nano-composite films: Effective strategies for probing and exploiting the photo-induced electron transfer of photosensitive membrane protein, *Biosens. Bioelectron.* 22 (2007) 1173-1185.
- [45] L. Johnson, F.K. Perkins, T. O'Hearn, P. Skeath, C. Merritt, J. Frieble, S. Sadda, M. Humayun & D. Scribner, Electrical stimulation of isolated retina with microwire glass electrodes, *Journal of Neuroscience Methods*, 137 (2004) 265-273.

[46] E. Greenbaum, M. Humayun, B.L. Justus, J.D. Weiland, E. Bolden, C.D. Merritt, I. Lee & J.W. Lee, Towards a Retinal Prosthesis: Integration of Microchannel Glass and Photosynthetic Structures into Photoelectrode Array Implants, NIH Symposium. Nanoscience and Nanotechnology: Shaping Biomedical Research(2000) 31-32.