



Aalborg Universitet

AALBORG UNIVERSITY
DENMARK

Morse-Smale Functions and the Space of Height-parameterized Flow Lines

Leth, John-Josef

Publication date:
2007

Document Version
Publisher's PDF, also known as Version of record

[Link to publication from Aalborg University](#)

Citation for published version (APA):
Leth, J.-J. (2007). *Morse-Smale Functions and the Space of Height-parameterized Flow Lines*. Department of Mathematical Sciences, Aalborg University.

General rights

Copyright and moral rights for the publications made accessible in the public portal are retained by the authors and/or other copyright owners and it is a condition of accessing publications that users recognise and abide by the legal requirements associated with these rights.

- Users may download and print one copy of any publication from the public portal for the purpose of private study or research.
- You may not further distribute the material or use it for any profit-making activity or commercial gain
- You may freely distribute the URL identifying the publication in the public portal -

Take down policy

If you believe that this document breaches copyright please contact us at vbn@aub.aau.dk providing details, and we will remove access to the work immediately and investigate your claim.

Morse-Smale Functions and the Space of Height-parameterized Flow Lines

————— ◊ —————

PhD Thesis

John-Josef Leth

June 19, 2007

— ◊ —

AALBORG UNIVERSITY
DEPARTMENT OF MATHEMATICAL SCIENCES · FREDRIK BAJERS VEJ 7G
9220 AALBORG EAST

Preface

This dissertation is the result of the author's PhD studies at the Department of Mathematical Sciences at Aalborg University, and has been written under supervision of Dr. Martin Raussen.

Acknowledgement

I wish to express my sincere gratitude to family, friends, and colleagues who have offered their support during my PhD-study.

Aalborg, February 27, 2007

John-Josef Leth

Some minor corrections have been made to this edition of the dissertation. Moreover, the self indexing assumption on the Morse function in appendix A has been removed. Finally, thanks to Dr. David E. Hurtubise for his many usefull comments.

Aalborg, June 19, 2007

John-Josef Leth

Summary

The main object of study in this thesis is the space of broken (gradient) flow lines of a Morse-Smale function. Throughout we fix a Morse function $f : M \rightarrow \mathbb{R}$ on a closed n -manifold M and a Riemannian metric g on M such that the pair (f, g) is Morse-Smale.¹

For critical points $p, q \in \text{Crit}(f)$ one defines the space of connecting orbits $W(p, q) \subset M$ as the transverse intersection of the unstable manifold $W^u(p)$ and the stable manifold $W^s(q)$. The orbit space $M(p, q) = W(p, q)/\mathbb{R}$ induced by the flow of the negative gradient $-\nabla f$ is called the moduli space of orbits; it lies at the foundation of modern Morse theory.

We start this thesis by recalling some background material from the theory of dynamical systems, such as the stable manifold theorem and various concepts related to it. We then use a dynamical system approach to present Morse theory. In particular we describe the Morse-Smale-Witten chain complex using moduli spaces, which leads to the statement of the Morse homology theorem.

The space of broken flow lines² $\overline{M}(q, p)$ can be viewed as a compactification of $M(p, q)$. It is a subspace of $C([f(q), f(p)], M)$, the space of continuous functions $[f(q), f(p)] \rightarrow M$ with the compact open topology, and defined by $\beta \in \overline{M}(q, p)$ iff $d\beta/dt = \nabla f(\beta)/|\nabla f(\beta)|^2$ on $M - \text{Crit}(f)$ with boundary conditions $\beta(f(q)) = q$ and $\beta(f(p)) = p$.

Each element β of $\overline{M}(q, p)$ has the important property of being height-parameterized, i.e. $f(\beta(t)) = t$ for all $t \in [f(q), f(p)]$. This description of the space

¹Assumptions such as f is self indexing and/or has only one minimum/maximum, g is compatible with the Morse charts, and M orientable will be applied when necessary.

²The order of the pair (q, p) in $\overline{M}(q, p)$ is to indicate that elements of this space start at q and ends at p , whereas elements of $M(p, q)$, when identified with flow lines, does the opposite. See also remark 2.6 and below this.

of broken flow lines appeared in the preprint [CJS95], which is a followup to [Coh92].

In the first part of this thesis we prove that $\overline{M}(q, p)$ is a compactification of $M(p, q)$. More precisely we identify $M(p, q)$ with a subspace $M'(p, q)$ of the compact metric space (\mathcal{CM}, d_H) , the set of nonempty closed subspaces of M with the Hausdorff distance d_H . The closure of $M'(p, q)$ is then a compactification of $M(p, q)$. On the other hand, we may identify $M(p, q)$ with a subspace $M(q, p)$ of $C([f(q), f(p)], M)$ and take the closure (which is compact by the Arzela-Ascoli theorem) of this space as a compactification of $M(p, q)$. A standard result concerning the convergence of flow lines to broken ones enables us to show that the two compactifications of $M(p, q)$ are the same and agree with $\overline{M}(q, p)$ (as topological spaces).

This compactification result also appeared in [CJS95], however our approach is not the one used in [CJS95]. In [CJS95] the compactification result rests upon a gluing construction of flow lines, whereas it does not in this thesis.³

Having given a careful description of $\overline{M}(q, p)$ we proceed by first investigating the connectivity of $\overline{M}(q, p)$. Secondly we address the question of whether or not the number of path components of $M(q, p)$ and its compactification $\overline{M}(q, p)$ are the same, i.e. does the inclusion $M(q, p) \hookrightarrow \overline{M}(q, p)$ induce a bijection on π_0 ? This should be seen as the start of a project where we investigate whether the inclusion $M(q, p) \hookrightarrow \overline{M}(q, p)$ induces a (weak) equivalence in homotopy or homology. Since $M(q, p) \approx M(p, q)$ can be given the structure of a smooth $(\lambda_p - \lambda_q - 1)$ -manifold it is clear that homology computations for $\overline{M}(q, p)$ becomes easier, in particular since duality theorems are at hand.⁴

To study the connectivity of $\overline{M}(q, p)$, we consider, for each $\beta \in \overline{M}(q, p)$ various restrictions $\beta|[\tau_i, \tau_j]$ with $[\tau_i, \tau_j] \subseteq [f(q), f(p)]$. In this way we obtain a family of (quotient) spaces where each element can be described by these restrictions, and a family of restriction maps between these spaces. Since these maps are closed surjections and the elements of the two families fit together in pullback diagrams, we can apply the Vietoris-Begle mapping theorem to conclude that the restriction maps induce isomorphisms in Čech cohomology in a certain range of degrees. In particular we are able to conclude that $\overline{M}(q, p)$ is connected if there are no critical points of index 1 (or $n - 1$) and precisely one critical point

³It should be mentioned that the aim of [CJS95] (and [Coh92]) are not the compactification result as such, but to recover the topology of M from the classifying space of a topological category \mathbf{C} , with $\text{Obj} = \text{Crit}(f)$ and $\text{Mor}(q, p) = \overline{M}(q, p)$.

⁴See also section 6.1 in chapter 6.

q of index 0 and precisely one critical point p of index n .

The next part of this thesis concerns the question of whether or not the inclusion $\iota : M(q, p) \hookrightarrow \overline{M}(q, p)$ induces a bijection on π_0 , i.e. is the number of path components of $M(q, p)$ invariant under closure. The surjectivity of $\pi_0(\iota)$ is proven in the case where the Riemannian metric g is compatible with the Morse charts. It is a consequence of a (new) gluing theorem for height-parameterized flow lines, which allows us to continuously deform any broken flow line into a height-parameterized flow line.

Concerning the injectivity of $\pi_0(\iota)$ we have so far only obtained partial results. We prove that if f is self indexing with precisely one minimum q and one maximum p , and g is compatible with the Morse charts, then the inclusion $M(q, p) \hookrightarrow (M(q, p) \cup B^1 \cup B^2)$ induces a bijection on π_0 , where $B^1 \subset \overline{M}(q, p)$ denotes the subspace whose elements are flow lines which break precisely at one critical point (between q and p) and $B^2 \subset \overline{M}(q, p)$ denotes the subspace whose elements are flow lines which break precisely at two critical points, say a and b , with either $\lambda_a = 1$ and $\lambda_b = 2$, or $\lambda_a = n - 2$ and $\lambda_b = n - 1$. If $\dim(\mathbf{M}) = 3$ this implies that $M(q, p) \hookrightarrow \overline{M}(q, p)$ induces a bijection on π_0 . The basic idea of the proof is first to consider a map $\rho \in C([0, 1], 0, 1), (\overline{M}(q, p), \eta, \eta')$ with $\eta, \eta' \in M(q, p)$, such that $\text{im}(\rho(s))$ contains at most two critical points (besides q and p) for all $s \in [0, 1]$. For $\tau \in]0, 1[$ we then consider the level τ -map $s \mapsto \rho(s)(\tau) \in M^\tau = \mathbf{M} \cap f^{-1}(\tau)$, and perturb it to a continuous map with image in $W(p, q)$. It is then easy to show that this perturbation induces a map in $C([0, 1], 0, 1), (M(q, p), \eta, \eta')$. The perturbation relies on a technical construction which, loosely described, splits a neighborhood of the unstable manifold connected to a critical point of index $n - 2$ (or 2) into a number of cone like sections.

Moreover, if the compatibility assumption on g is omitted then $M(q, p) \hookrightarrow (M(q, p) \cup A^1)$ (and $M(q, p) \hookrightarrow \overline{M}(q, p)$ if $\dim(\mathbf{M}) = 3$) induces an injection on π_0 , where $A^1 \subset \overline{M}(q, p)$ denotes the subspace whose elements are flow lines which break precisely at one critical point, say a , with either $\lambda_a = 1$ or $\lambda_a = n - 1$.

We proceed in the final part of this thesis with an analysis of the number of path components $\#\overline{M}(q, p)$ of $\overline{M}(q, p)$ in the special case of an orientable three dimensional manifold, f self indexing with precisely one minimum q and one maximum p , and g compatible with the Morse charts. The main result is an estimate of $\#\overline{M}(q, p)$ which only depends on the number of critical points and the intersection numbers used to define the boundary operator from the Morse-

Smale-Witten chain complex. To obtain this estimate we define three graphs (one dimensional CW-complexes), each embedded at different level surfaces. Using Poincaré-Lefschetz duality we obtain an expression for $\#\overline{M}(q, p)$ in terms of these graphs. More precisely, let Γ be the union of the stable and unstable spheres at level $\tau \in]1, 2[$ and $i : \Gamma \hookrightarrow f^{-1}(\tau)$ the inclusion. If we consider Γ as a graph the expression for $\#\overline{M}(q, p)$ is given in terms of the number of components of Γ , the number of vertices of Γ , and $\dim(\mathbb{H}_1(i))$ where \mathbb{H}_* denotes singular homology with real coefficients. The first two terms can be computed by means of the number of critical points and the intersection numbers. The only unknown term in the expression for $\#\overline{M}(q, p)$ is $\dim(\mathbb{H}_1(i))$. We show that $2g - \dim(\mathbb{H}_1(M)) \leq \dim(\mathbb{H}_1(i)) \leq 2g$, where g denotes the number of critical points of index one (or equivalently, of index two).

For a given Morse-Smale pair (f, \mathbf{g}) on a closed n -manifold with \mathbf{g} compatible with the Morse charts we prove, in the appendix of this thesis, that the closure of any unstable manifold is a prestratified space which is (A)-regular (that is, satisfies the Whitney condition (A)) at any noncritical point. This result is unrelated to the results obtained in the main text.

Summary in Danish

Denne afhandling er centreret om et studie af rummet af brudne flow linjer hørende til en Morse-Smale funktion. Lad os i det følgende fastholde en Morse funktion $f : M \rightarrow \mathbb{R}$ på en lukket n -mangfoldighed og en Riemannsk metrik g på M således at parret (f, g) er Morse-Smale.⁵

For kritiske punkter $p, q \in \text{Crit}(f)$ defineres rummet $W(p, q) \subset M$ af forbindende baner som det transverse snit af den ustabile mangfoldighed $W^u(p)$ og den stabile mangfoldighed $W^s(q)$. Banerummet $M(p, q) = W(p, q)/\mathbb{R}$ induceret af flowet hørende til den negative gradient $-\nabla f$, kaldes modulirummet af baner; det udgør en af hjørnestenene i moderne Morse teori.

Vi starter denne afhandling med at genkalde baggrundsmateriale fra teorien om dynamiske systemer, så som den stabile mangfoldigheds sætning, samt andre koncepter forbundet hertil. Vi giver herefter en præsentation af Morse teori via dynamiske systemer. Specielt beskrives Morse-Smale-Witten kædekomplekset ved hjælp af modulirum, hvilket leder til Morse homologi sætningen.

Rummet af brudne flow linjer⁶ $\overline{M}(q, p)$ er en kompaktifisering af $M(p, q)$. Det er et delrum af $C([f(q), f(p)], M)$, rummet af alle kontinuere funktioner $[f(q), f(p)] \rightarrow M$ med den kompakt åbne topologi, og defineret ved $\beta \in \overline{M}(q, p)$ hvis og kun hvis $d\beta/dt = \nabla f(\beta)/|\nabla f(\beta)|^2$ på $M - \text{Crit}(f)$ med randbetingelser $\beta(f(q)) = q$ og $\beta(f(p)) = p$.

Ethvert element β i $\overline{M}(q, p)$ har følgende vigtige egenskab $f(\beta(t)) = t$ for alle $t \in [f(q), f(p)]$, og siges at være højde parametriseret. Denne beskrivelse af

⁵Antagelser så som f er selv indekserende og/eller har kun et minimum/maksimum, g er kompatibel med Morse kortene, og M er orienterbar vil blive anvendt om nødvendigt.

⁶Ordenen af parret (q, p) i $\overline{M}(q, p)$ indikerer at elementer i dette rum starter i q og slutter i p , hvorimod elementer i $M(p, q)$, når identificeret med flow linjer, opføre sig modsat. Se også remark 2.6 og teksten under denne.

rummet af brudne flow linjer optræder i preprintet [CJS95], som er en opfølgning til [Coh92].

I den første del af denne afhandling bevises det, at $\overline{M}(q, p)$ er en kompaktifisering af $M(p, q)$. Mere præcist, $M(p, q)$ identificeres med et delrum $M'(p, q)$ af det kompakte metriske rum (CM, d_H) , bestående af ikke-tomme lukkede delmængder af M med Hausdorff afstanden d_H . Aflukningen af $M'(p, q)$ er da en kompaktifisering af $M(p, q)$. På den anden side kan vi identificere $M(p, q)$ med et delrum $M(q, p)$ af $C([f(q), f(p)], M)$ og bruge aflukningen (som er kompakt pga. Arzela-Ascoli's sætning) af dette delrum som en kompaktifisering af $M(p, q)$. Et standard resultat omhandlende konvergens af flow linjer til brudne flow linjer gør os da i stand til at vise at de to kompaktifiseringer af $M(p, q)$ er de samme og stemmer overens med $\overline{M}(q, p)$ (som topologiske rum).

Dette kompaktifiserings resultat nævnes også i [CJS95], men vores tilgang er ikke den brugt i [CJS95]. I [CJS95] afhænger kompaktifiseringen af et gluing resultat, dette er ikke tilfældet her.⁷

Efter at have givet en detaljeret beskrivelse af $\overline{M}(q, p)$ fortsætter vi med en undersøgelse af sammenhængsegenskaber ved $\overline{M}(q, p)$. Derudover adresseres spørgsmålet om hvorvidt antallet af sammenhængskomponenter for $M(q, p)$ og dens kompaktifisering $\overline{M}(q, p)$ er de samme, dvs. inducerer inklusionen $M(q, p) \hookrightarrow \overline{M}(q, p)$ en bijektion på π_0 ? Dette skal ses som starten på et projekt hvor vi ønsker at afgøre hvorvidt inklusionen $M(q, p) \hookrightarrow \overline{M}(q, p)$ inducerer en (svag) ækvivalens i homotopi eller homologi. Eftersom man kan give $M(q, p) \approx M(p, q)$ strukturen af en glat $(\lambda_p - \lambda_q - 1)$ -mangfoldighed, er det klart, at homologi beregninger af $\overline{M}(q, p)$ bliver lettere, specielt da dualitets sætninger nu kan anvendes.⁸

For at studere sammenhængsegenskaberne ved $\overline{M}(q, p)$ analyseres, for ethvert $\beta \in \overline{M}(q, p)$, forskellige restriktioner $\beta|_{[\tau_i, \tau_j]}$ hvor $[\tau_i, \tau_j] \subseteq [f(q), f(p)]$. På denne måde opnås en familie af (kvotient-) rum hvori ethvert element kan beskrives ved disse restriktioner, samt en familie af restriktions afbildninger mellem rummene. Da restriktions afbildningerne er lukkede surjektioner, og de to familier passer sammen i et pullback diagram, kan Vietoris-Begle's afbildnings sætning anvendes til at konkludere at restriktions afbildningerne inducerer isomorfier i Čech kohomologi indenfor et vist interval af grader. Specielt kan

⁷Det skal nævnes at målet med [CJS95] (og [Coh92]) ikke er kompaktifiserings resultatet som sådan, men at rekonstruere topologien på M fra det klassificerende rum hørende til en topologisk kategori \mathcal{C} , hvor $\text{Obj} = \text{Crit}(f)$ og $\text{Mor}(q, p) = \overline{M}(q, p)$.

⁸Se også afsnit 6.1 i kapitel 6.1.

vi konkludere at $\overline{M}(q, p)$ er sammenhængende hvis der ikke er nogle kritiske punkter med indeks 1 (eller $n - 1$) samt præcist ét kritisk punkt q af indeks 0 og præcist ét kritisk punkt p af indeks n .

Den næste del af afhandlingen drejer sig om hvorvidt inklusionen $\iota : M(q, p) \hookrightarrow \overline{M}(q, p)$ inducerer en bijektion på π_0 , dvs. er antallet af kurvesammenhængskomponenter af $M(q, p)$ invariant under aflukning? Surjektiviteten af $\pi_0(\iota)$ bevises under antagelse af, at den Riemannske metrik g er kompatibel med Morse kortene. Dette er en konsekvens af en (ny) gluing sætning for højde parametriserede flow linjer, hvilken tillader os at deformere enhver bruden flow linje kontinuert til en højde parametriseret flow linje.

Angående injektiviteten af $\pi_0(\iota)$ har vi indtil videre kun opnået delresultater. Vi beviser at hvis f er selv indekserende med præcist ét minimum q og præcist ét maksimum p , og g er kompatibel med Morse kortene, så inducerer inklusionen $M(q, p) \hookrightarrow (M(q, p) \cup B^1 \cup B^2)$ en bijektion på π_0 , hvor $B^1 \subset \overline{M}(q, p)$ betegner delrummet hvis elementer er de flow linjer som knækker præcist i ét kritisk punkt (mellem q og p), og $B^2 \subset \overline{M}(q, p)$ betegner delrummet hvis elementer er de flow linjer som knækker præcist i to kritiske punkter, f.eks. a og b , hvor enten $\lambda_a = 1$ og $\lambda_b = 2$, eller $\lambda_a = n - 2$ og $\lambda_b = n - 1$. Hvis $\dim(M) = 3$ medfører dette, at $M(q, p) \hookrightarrow \overline{M}(q, p)$ inducerer en bijektion på π_0 . Ideen bag beviset er først at betragte en afbildning $\rho \in C([0, 1], 0, 1, (\overline{M}(q, p), \eta, \eta'))$ hvor $\eta, \eta' \in M(q, p)$ og $\text{im}(\rho(s))$ højst indeholder to kritiske punkter (udover q og p) for alle $s \in [0, 1]$. For $\tau \in]0, 1[$ betragtes da følgende niveau τ -afbildning $s \mapsto \rho(s)(\tau) \in M^\tau = M \cap f^{-1}(\tau)$, som perturberes til en kontinuert afbildning med billede i $W(p, q)$. Det er da ikke svært at vise at denne perturbation inducerer en afbildning i $C([0, 1], 0, 1, (M(q, p), \eta, \eta'))$. Perturbationen afhænger af en teknisk konstruktion som, løst sagt, opsplitter en omegn af den ustabile mangfoldighed, hørende til et kritisk punkt af indeks $n - 2$ (eller 2), op i et antal kegle lignende områder.

Hvis kompatibilitets betingelsen på g ikke medtages, inducerer $M(q, p) \hookrightarrow (M(q, p) \cup A^1)$ (og $M(q, p) \hookrightarrow \overline{M}(q, p)$ hvis $\dim(M) = 3$) en injektion på π_0 , hvor $A^1 \subset \overline{M}(q, p)$ betegner delrummet hvis elementer er de flow linjer som knækker præcist i et kritisk punkt, f.eks. a , hvor enten $\lambda_a = 1$ eller $\lambda_a = n - 1$.

I den sidste del af denne afhandling analyseres antallet af kurvesammenhængskomponenter $\#\overline{M}(q, p)$ af $\overline{M}(q, p)$, i tilfældet af en orienterbar tre dimensional mangfoldighed, f selv indekserende med præcist ét minimum q og præcist ét maksimum p , og g er kompatibel med Morse kortene. Hovedresultatet er her et estimat for $\#\overline{M}(q, p)$ som kun afhænger af antallet af kritiske punkter og snittallene

hørende til rand operatoren fra Morse-Smale-Witten kædekomplekset. For at opnå dette estimat defineres først tre grafer (1-dimensionale CW-komplekser). Ved anvendelse af Poincaré-Lefschetz dualitet opnås et udtryk for $\#\overline{M}(q, p)$ givet ved disse grafer. Mere præcist, lad Γ betegne foreningen af de ustabile og stabile cirkler på niveau $\tau \in]1, 2[$ og lad $i : \Gamma \hookrightarrow f^{-1}(\tau)$ betegne inklusionen. Hvis vi betragter Γ som en graf, kan $\#\overline{M}(q, p)$ udtrykkes ved antallet af sammenhængskomponenter af Γ , antallet af punkter i Γ , og $\dim(\mathbb{H}_1(i))$ hvor \mathbb{H}_* betegner singulær homologi med reelle koefficienter. De to første kan udregnes ved hjælp af antallet af kritiske punkter og snittallene. Den eneste ubekendte i udtrykket for $\#\overline{M}(q, p)$ er $\dim(\mathbb{H}_1(i))$. Vi viser at $2g - \dim(\mathbb{H}_1(\mathbb{M})) \leq \dim(\mathbb{H}_1(i)) \leq 2g$, hvor g betegner antallet af kritiske punkter med indeks 1 (eller ækvivalent, med indeks 2).

For et givet Morse-Smale par (f, g) på en lukket n -mangfoldighed hvor g er kompatibel med Morse kortene beviser vi, i appendikset til denne afhandling, at aflukningen af enhver ustabil mangfoldighed er et pre-stratificeret rum som er (A)-regulær (dvs. tilfredsstiller Whitney's betingelse (A)) i ethvert ikke kritisk punkt. Dette resultat er ikke relateret til resultaterne fra hovedteksten.

Contents

1	Preliminaries	1
1.1	Notes to the reader	1
1.2	Dynamical systems	2
1.3	Morse Theory	5
1.3.1	Appendix	10
2	The space of broken flow lines and related spaces	13
2.1	The space of connecting orbits	14
2.2	The moduli space of orbits	15
2.3	Broken orbits and convergence	16
2.4	The space of height-parameterized flow lines	20
2.5	The space of broken flow lines	28
2.5.1	Appendix	30
3	Connectivity and the space of broken flow lines	35
3.1	Assumptions	36
3.2	Quotients of the space of broken flow lines	36
3.3	Pullbacks and induced isomorphisms	39
3.4	Appendix	45
4	Path components and the space of broken flow lines	49

4.1	A gluing construction	50
4.1.1	Extension of the gluing map	55
4.2	Surjectivity of $M(q, p) \hookrightarrow \overline{M}(q, p)$ on π_0	56
4.3	On the injectivity of $M(q, p) \hookrightarrow \overline{M}(q, p)$ on π_0	58
4.4	Extending injectivity	64
5	Estimating the number of path components of the space of broken flow lines	73
5.1	Graphs on level surfaces	74
5.2	Estimates of $\#\overline{M}(q, p)$	76
5.2.1	77
5.2.2	79
5.3	Appendix	82
5.3.1	82
5.3.2	82
6	Main results and future work	85
6.1	Chapter 2	85
6.2	Chapter 3	86
6.3	Chapter 4	87
6.4	Chapter 5	87
A	Appendix	89
A.1	Stratification	89
A.2	The main result	90
A.3	Future work	93

Chapter 1

Preliminaries

In this chapter we present various elements from the theory of dynamical system and Morse theory. The reason being an attempt to make this work as self contained as possible. The reader familiar with basic concepts and results from these two fields should be able to skip this chapter, with the exception of section 1.1.

In section 1.2 we present some basic concepts and results from the theory of dynamical systems, the aim being to state the stable manifold theorem. The main reference for this section is [Irw01] and [PdM82]. Using notation and results from section 1.2 we give an account for present day Morse theory in section 1.3 ending with the Morse homology theorem. The main reference for this section being [BH04] and to some extent [Web06]. In appendix 1.3.1 we summarize some of the classical theorems of Morse theory.

Since this chapter only contains background material and to keep the text readable, we have decided to put most references in footnotes. Moreover and as said above the references [Irw01], [PdM82], [BH04] and [Web06] will be sufficient in most cases.

1.1 Notes to the reader

The following are assumed throughout the thesis unless otherwise stated. Manifolds are finite dimensional, 2^{nd} countable, and Hausdorff. Manifolds are always

connected and without boundary. In addition to the above it will be assumed in most of the text that manifolds are closed i.e. compact and without boundary. Objects and morphisms are in smooth categories whenever this makes sense.

The notation \approx will always denote an isomorphism in the category under consideration, and \simeq will denote a homotopy.

References are written as ([Irw01],Ch.4.II) meaning chapter 4.II of [Irw01], where Ch. can be replaced by App. or p. meaning appendix and page respectively.

1.2 Dynamical systems

Let \mathbb{R} be the abelian Lie group of real numbers. By a dynamical system on a manifold M we understand a group action $\varphi : \mathbb{R} \times M \rightarrow M$; $(t, m) \mapsto \varphi(t, m) = t.m$, called a flow on M . Hence the theory of group actions applies. In the sequel fix a flow φ on M .

The group action axioms imply that $\varphi_t \in \text{Diff}(M)$ for the time t map $m \mapsto \varphi_t(m) = t.m$, therefore φ or $\{\varphi_t\}$ are sometimes called a one parameter group of diffeomorphisms of M . The flow defines an equivalence relation on M by $m \sim m'$ iff there exist $t \in \mathbb{R}$ such that $\varphi_t(m) = m'$. The resulting quotient space $M/\sim = M/\mathbb{R}$ is called the orbit space and the equivalence class $[m] \in M/\mathbb{R}$ the orbit through m , which basically is the same as the orbit $\mathbb{R}.m$ of m .

The partial map $t \mapsto \varphi_m(t) = t.m$ is called the flow line (or integral curve) at m , and $\frac{d}{dt}\varphi_m(t) = \dot{\varphi}_m(t)$ the velocity at $\varphi_m(t)$ at time t . The flow generates a vector field $X^\varphi = X$ by $X(m) = \dot{\varphi}_m(0)$, sometimes called the velocity vector field of φ or the infinitesimal generator of φ . Hence $X(m) = \dot{\varphi}_{m'}(t)$ if $m = \varphi_{m'}(t)$ since the velocity at any point is independent of time by the group action axioms. Therefore φ_m is an integral curve of X ($X(\varphi_m) = \dot{\varphi}_m$) for all m . As a consequence of the Picard-Lindelöf theorem we have conversely that any $X \in \mathcal{T}M$ gives rise to a partial flow $\psi^X = \psi : D \rightarrow M$, here $D \subset (\mathbb{R} \times M)$ an open neighborhood of $\{0\} \times M$, such that for all $m \in M$, $\psi_m : D_m \subseteq \mathbb{R} \rightarrow M$ is the maximal integral curve of X at m . Basically a partial flow is a “flow” which is not defined for all time but still fulfills the axioms of a group action whenever this makes sense. If $D = \mathbb{R} \times M$ then X is called complete. Moreover, if M is compact, then X is complete and hence ψ is a flow, sometimes called an integral flow.¹

¹The above can be found in ([Irw01],p.39,60-75) and ([AM78],Ch.2.1).

Let φ be a flow with velocity vector field X , and let $\text{Fix}(\varphi) = \{p \in M \mid \mathbb{R} \cdot p = p\}$ denote the set of fixed points of φ , which of course is equal to $\text{Sing}(X) = \{p \in M \mid X(p) = 0\}$, the set of singular points of X . Let $p \in \text{Fix}(\varphi)$, then $d\varphi_t(p) \in GL(T_p M)$ induces a smooth map $\Phi : \mathbb{R} \times T_p M \rightarrow T_p M$; $(t, u) \mapsto d\varphi_t(p)u$ which is linear in u , i.e. Φ_t is linear. Moreover, Φ is a flow² and hence generates a (linear) vector field $H : T_p M \rightarrow T_p M$. From the theory of linear systems we know that $\Phi(t, u) = \exp(tH)u$. In fact, H is the (Riemannian) Hessian $H_p X$ of X at p , i.e. the vertical part of the tangent map of X at p . For details regarding the Hessian see ([Irw01], p.111) or ([AM78], p.72), we merely remark that $TX : TM \rightarrow TTM$; $(p, u) \mapsto (p, X(p), u, dX(p)u)$ and $T_p X : u \mapsto (u, dX(p)u)$, hence $H_p X = dX(p)$.³

Since $d\varphi_t(p)u = \exp(tH_p X)u$, we have that u is an eigenvector of $H_p X$ with eigenvalue λ of multiplicity k iff u is an eigenvector of $d\varphi_t(p)$ with eigenvalue $\exp(t\lambda)$ of multiplicity k . In particular, for $t > 0$ we have that $\text{span}\{u_j, v_j\}$, where $u_j + iv_j$ is the generalized eigenvector of $d\varphi_t(p)$ corresponding to an eigenvalue $a_j + ib_j$ with $a_j^2 + b_j^2 > 1$, is precisely the generalized positive eigenspace $\text{Eig}^+ H_p X$ of $H_p X$, i.e. $\text{Eig}^+ H_p X = \text{span}\{u_j, v_j\}$ where $u_j + iv_j$ is the generalized eigenvector of $H_p X$ corresponding to an eigenvalue $a_j + ib_j$ with $a_j > 0$.⁴

A $p \in \text{Fix}(\varphi)$ is called hyperbolic if $\sigma(d\varphi_t(p)) \cap \mathbb{S}^1 = \emptyset$ for some (hence any) $t \neq 0$, where $\mathbb{S}^1 \subset \mathbb{C}$ is the unit circle and $\sigma(d\varphi_t(p))$ denotes the spectrum of the linear automorphism $d\varphi_t(p) \in GL(T_p M)$. Hence p is a hyperbolic fixed point if $d\varphi_t(p)$ has no eigenvalues of modulus 1. Note that $p \in \text{Fix}(\varphi)$ hyperbolic iff $p \in \text{Sing}(X = X^\varphi)$ hyperbolic, that is if $H_p X$ has no eigenvalues with real part zero. As a passing remark we note that hyperbolic singularities/fixed points are isolated if M is compact. Now an application of Hartman's theorem yields that a hyperbolic singularity p of X is flow equivalent to the zero of $H_p X$ i.e. there exists a homeomorphism $h : M' \rightarrow \mathbb{E}'$ from an open neighborhood of p to an open neighborhood of $0 = h(p)$ and an increasing continuous homomorphism $f : \mathbb{R} \rightarrow \mathbb{R}$ (i.e. f is multiplication by a positive constant) such that $h \circ \varphi = \Phi \circ (f \times h)$ where φ and Φ are the flows of X and $H_p X$ respectively.⁵

Let $p \in \text{Fix}(\varphi)$ be hyperbolic. The spectral decomposition theorem applied to

²With c a smooth curve on M such that $c(0) = p$ and $\dot{c}(0) = u$ we have $\Phi(0, u) = d\varphi_0 u = \partial_{s=0} \varphi_0(c(s)) = \partial_{s=0} c(s) = u$ and $\Phi(t + \tau, u) = \partial_{s=0} \varphi_t(\varphi_\tau(c(s))) = \partial \varphi_t(p) d\varphi_\tau(p) u = \Phi(t, \Phi(\tau, u))$.

³With notation as above we have $Hv = \partial_{t=0} \Phi(t, u) = \partial_{t=0} d\varphi(t, u) = \partial_{t=0} \partial_{s=0} \varphi(t, c(s)) = \partial_{s=0} \partial_{t=0} \varphi(t, c(s)) = \partial_{s=0} X(c(s)) = dX(p)u$, hence $H = dX(p)$.

⁴See ([PdM82], Ch.2.2) or ([Irw01], Ch.4) for details.

⁵For details see ([PdM82], Ch.2.3(2.4)) and ([Irw01], Ch.5.III).

the linear vector field $H_p X$ then yields a decomposition $T_p M = \mathbb{E}_p^u \oplus \mathbb{E}_p^s$ into $H_p X$ -invariant subspaces. Note then that $\mathbb{E}_p^u = \text{Eig}^+ H_p X$ (and $\mathbb{E}_p^s = \text{Eig}^- H_p X$), so \mathbb{E}_p^u may be characterized as $\{x \in \mathbb{E} \mid \varphi(t, x) \rightarrow 0, t \rightarrow -\infty\}$ or equivalently, for $t > 0$ fixed and $n \in \mathbb{N}$ as $\{x \in \mathbb{E} \mid (\varphi_t)^{-n} x \rightarrow 0, n \rightarrow \infty\}$. Now if we apply the spectral decomposition theorem to the linear automorphism $d\varphi_t(p)$ with $t > 0$ fixed, the splitting of $T_p M$ agrees with that induced by $H_p X$, so \mathbb{E}_p^u can also be described as the generalized eigenspace corresponding to eigenvalues of modulus greater than 1. Moreover, there exists an (equivalent) norm $|\cdot|$ on $T_p M$ given by $|x| = \max\{|x^u|, |x^s|\}$ with $x = x^u + x^s$ such that $\max\{|(d\varphi_t(p)^u)^{-1}|, |d\varphi_t(p)^s|\} < 1$, with $d\varphi_t(p) = d\varphi_t(p)^u \oplus d\varphi_t(p)^s$. Hence $d\varphi_t(p)^u$ is an expansion and $d\varphi_t(p)^s$ is a contraction w.r.t. $|\cdot|$.⁶

For $p \in \text{Fix}(\varphi)$ the unstable and stable set of φ at p are then defined as $W^u(p) = \{m \in M \mid \lim_{t \rightarrow -\infty} \varphi(t, m) = p\}$ and $W^s(p) = \{m \in M \mid \lim_{t \rightarrow \infty} \varphi(t, m) = p\}$ respectively. The (un)stable manifold theorem we now present can be seen as a global version of the spectral decomposition theorem. For a proof, other versions and generalizations see either [Irw01], [PdM82], [AR67], [Jos02] or [BH04].

1.1 Theorem.

Let p be a hyperbolic fixed point of a flow φ on M and $T_p M = \mathbb{E}_p^u \oplus \mathbb{E}_p^s$ the decomposition induced by $d\varphi_t(p)$ for fixed $t \neq 0$. Then $W^u(p)$ and $W^s(p)$ are immersed submanifolds, tangent at p to the (un)stable summands of $d\varphi_t(p)$. Moreover, $W^u(p)$ and $W^s(p)$ are the surjective images of injective immersions $\mathbb{E}_p^u \rightarrow W^u(p)$ and $\mathbb{E}_p^s \rightarrow W^s(p)$ respectively.

We end this section by introducing the concept of a Liapunov function. As we shall see the existence of such a function will imply that the immersions above are embeddings.

A function $f : M \rightarrow \mathbb{R}$ is called positive definite at $p \in M$ if f has a strict local minimum at p and $f(p) = 0$. We define positive semi definite by excluding the word strict, and negative (semi) definite in the obvious way. Let φ be a flow on M with $X = X^\varphi$. A function $f : M \rightarrow \mathbb{R}$ is said to be a Liapunov function for X (or φ) at a singularity $p \in M$ if f is positive definite at p and $L_X f : M \rightarrow \mathbb{R}; m \mapsto \left. \frac{d}{dt} \right|_{t=0} f(\varphi_t(m))$ is negative semi definite at p . We have the following variation of the above definition. Let φ be a flow on a compact manifold M with $X = X^\varphi$. A function $f : M \rightarrow \mathbb{R}$ is said to be a Liapunov function for X (or φ) if $L_X f < 0$ on $M - \text{Fix}(\varphi)$ i.e. on the complement of the fixed points of φ .⁷

⁶The above can be found in ([Irw01],Ch.6.2) and ([PdM82],Ch.2.6).

⁷See ([Irw01],App.5) and ([Shu87],Ch.3). One can also compare with ([Fra79],p.200),

1.2 Theorem.

Let the assumptions be as in theorem 1.1. Furthermore assume that M is compact and that there exists a Liapunov function for φ . Then $\mathbb{E}^u \rightarrow W^u(p)$ and $\mathbb{E}^s \rightarrow W^s(p)$ have continuous inverses, hence they are embeddings.

Proof:

Lemma 4.20 in [BH04] has the same conclusion but the assumptions are that φ is the flow of minus the gradient of a Morse function (see section 1.3). However, the proof only uses the fact that flow lines can not start and end at the same fixed point. But this is also true in our case. \square

1.3 Morse Theory

In this section we apply the notions from dynamical systems to the concept of a Morse function. Throughout let M denote a connected closed manifold modelled on $\mathbb{R}^n = \mathbb{E}$. Whenever possible we let $\psi : M' \rightarrow U$ denote a chart with $x = \psi(m)$, $M' \subseteq M$, $U \subseteq \mathbb{E}$, and if this chart is around a point $p \in M$ we sometimes set $\psi(p) = 0$.

Let $f : M \rightarrow \mathbb{R}$ be smooth and $\mathbf{g} = \langle \cdot | \cdot \rangle$ denote a Riemannian metric on M . The gradient (vector field), $\nabla f = \mathbf{grad} f \in \mathcal{T}M$, of f is then defined by $\langle X | \nabla f \rangle = df(X) = X(f)$ where $X \in \mathcal{T}M$. It is complete since M is compact.

Now let $\varphi : \mathbb{R} \times M \rightarrow M$ denote the flow corresponding to the negative gradient $-\nabla f$, and $\text{Crit}(f) = \{m \in M \mid df(m) = 0\}$ denote the set of critical points of f . It is easy to see that f is a Liapunov function for $-\nabla f$ and, since \mathbf{g} is positive definite, $p \in \text{Crit}(f)$ iff it is a singularity of $-\nabla f$, hence $p \in \text{Crit}(f)$ iff $p \in \text{Fix}(\varphi)$. A critical point p is called non-degenerate iff p is a hyperbolic fixed point of φ . Hence, $p \in \text{Crit}(f)$ is non-degenerate iff p is a hyperbolic singularity of $-\nabla f$. In this case, Hartman's theorem implies that the hyperbolic singularity p of $-\nabla f$ is flow equivalent to the zero of the Hessian $H_p(-\nabla f) = -H_p \nabla f$. For $p \in \text{Crit}(f)$ non-degenerate the index λ_p of p is defined as $\lambda_p = \dim W^u(p) = \dim \mathbb{E}_p^u = \dim(\text{Eig}^- H_p \nabla f)$, hence $\dim W^s(p) = n - \lambda_p$ and by theorem 1.2 the unstable and stable manifolds are embedded open disks, therefore contractible hence orientable.⁸

Let us look at the situation locally. In a chart ψ let $\{\partial_i(x) = \frac{\partial}{\partial x_i}(x)\}$ denote a

[Fra82],p.8) or [Mey68].

⁸See ([Hir94],p.104). This can be compared to ([Web06],Ch.2.2)

basis for $T_x U = \mathbb{E}$, and $[g^{ij}] = [g_{ij}]^{-1} = [g(\partial_i, \partial_j)]^{-1}$. By abuse of notation we write ∇f for the principal part of $\psi_*(\nabla f)$ the local representative of ∇f , and φ for $\psi \circ \varphi_t \circ \psi^{-1}$ the local representative of φ . We then have local formulas $\nabla f = [g^{ij}] \mathbf{D}(f \circ \psi^{-1})$ and $\mathbf{D}\nabla f = \mathbf{D}[g^{ij}] \mathbf{D}(f \circ \psi^{-1}) + [g^{ij}] \mathbf{D}^2(f \circ \psi^{-1})$. If ψ is a chart around $p \in \text{Crit}(f)$ then $\mathbf{D}\nabla f(0) = [g^{ij}(0)] \mathbf{D}^2(f \circ \psi^{-1})(0)$ is a symmetric matrix, hence diagonalizable with real eigenvalues. So λ_p is the number of negative eigenvalues counted with multiplicity of the Hessian $-\mathbf{H}_p \nabla f = -\mathbf{D}\nabla f(0)$, and p is non-degenerate iff $\det(\mathbf{D}^2(f \circ \psi^{-1})(0)) \neq 0$ since $[g^{ij}]$ is positive definite.⁹

Since $\lambda_p = \dim W^u(p)$, the local description of λ_p is of course independent of the choice of chart. As a consequence of Sylvester's law of inertia, this can also be seen directly since a change of coordinates does not alter the signs of the eigenvalues of $-\mathbf{H}_p \nabla f$ (see e.g. ([HJ85],p.224)). Moreover, since $[g^{ij}]$ is positive definite we may choose a basis (i.e. a coordinate change) such $[g^{ij}] = \mathbf{1}$, hence λ_p is uniquely determined by $\mathbf{D}^2(f \circ \psi^{-1})(0)$ the local Hessian of f at p .¹⁰

1.3 Remark: Note that globally $\mathbf{D}^2(f \circ \psi^{-1})(0)$ correspond the symmetric bilinear function $\mathbf{H}_p f : T_p M^2 \rightarrow \mathbb{R}; (v, w) \mapsto v'_p(w'(f)) = v(w'(f))$ where $v', w' \in TM$ are vector field extensions of v, w . Moreover, $p \in \text{Crit}(f)$ is non-degenerate iff $\mathbf{H}_p f$ is non-degenerate, i.e. $\dim(\text{Null}(T_p M)) = 0$ where $\text{Null}(T_p M) = \{v \in T_p M \mid \mathbf{H}_p f(v, w) = 0 \forall w\}$, and λ_p can equivalently be described as the maximal dimension of a subspace of $T_p M$ on which the quadratic function $\mathbf{H}_p f(v) = \mathbf{H}_p f(v, v)$ is negative definite ($\mathbf{H}_p f(v) < 0, \forall v \in T_p M - \{0\}$). This is the classical way of introducing the notion of a non-degenerate critical point. ■

The function f is called Morse (or a Morse function) if all its critical points are non-degenerate. Let $\text{Crit}_i(f) = \{p \in \text{Crit}f \mid \lambda_p = i\}$. In particular, $\text{Crit}(f)$ is finite and closed if f is Morse, and $\lim_{t \rightarrow \pm\infty} \varphi(t, m) \in \text{Crit}(f)$ for all $m \in M$. The existence of Morse functions is guaranteed since the set of C^r Morse functions is open and dense in $C^r(M, \mathbb{R})$ for $2 \leq r \leq \infty$.¹¹

1.4 Theorem. (Morse Lemma)

Let $f \in C^{r+2}(M, \mathbb{R})$ for $1 \leq r \leq \infty$ with M a connected n -manifold. Then

⁹For the local computations see ([BH04],Ch.4.1). One can compare this with ([Jos02],p.139+289).

¹⁰See ([Gre67],Ch.IX.2) and compare with ([Kos93],Ch.IV.4).

¹¹For the first part see ([BH04],Ch.3.2), ([Jos02],Ch.6.4) or ([Web06],Ch.2.1). For the second part see ([Hir94],p.147) and compare with ([BH04],p.50) and ([Mat02],p.47).

$p \in \text{Crit}_i(f)$ non-degenerate iff there exists a C^r (Morse) chart ψ such that

$$f \circ \psi^{-1}(x) = f(p) - \sum_{j=1}^i x_j^2 + \sum_{j=i+1}^n x_j^2$$

For a traditional proof based on the diagonalization of symmetric matrices see ([Hir94], Ch.6) or ([Mil63], §2). For a proof based on the Moser path method see ([BH04], Ch.3.1), ([Jos02], Ch.6.3) or ([Lan99], Ch.VII.5).

Note that, in general, we can not compute an explicit formula for ∇f from the Morse lemma, due to \mathbf{g} . A gradient vector field ∇f , with f Morse, is in standard form near a hyperbolic singularity p if there exists a chart ψ such that $\nabla f = \frac{1}{2}\mathbf{D}(f \circ \psi^{-1})$ in U . Moreover, \mathbf{g} is compatible with the Morse charts if ∇f is in standard form near all p . Using a bump function one can, however, always pull back the standard metric on \mathbb{E} , to modify \mathbf{g} , such that $\mathbf{g}^{ij} = \delta_{ij}$ on a small neighborhood of p . Hence \mathbf{g} can always be modified to be compatible with the Morse charts for f .¹²

1.5 Remark: Before we proceed to the Morse-Smale property we remark that there is yet another (equivalent) way of introducing the notion of a Morse function.

Let $f : M \rightarrow \mathbb{R}$ be smooth and $Z^* \subset T^*M$ denote the zero section of the cotangent bundle. Then $p \in M$ is called critical if $df(p) \cap Z_p^* \neq \emptyset$ and non-degenerate if $df \pitchfork_p Z^*$, i.e. critical if df intersects Z^* over p and non-degenerate if this intersection is transversal. The function f is called Morse if $df \pitchfork Z^*$, i.e. if all critical points are non-degenerate.

Since transversality is a generic property, one usually use the above view point when proving generic properties of the space of Morse functions. Moreover, the notion of hyperbolic can be described purely by means of transversality.¹³ ■

A Morse function f (or the pair (f, \mathbf{g})) is Morse-Smale if $W^u(p) \pitchfork W^s(q)$ for all critical points p and q . Note that this depends on both f and \mathbf{g} .¹⁴ We remark that the spaces $W(p, q)$ and $M(p, q)$ (to be defined below) are described in more detail in chapter 2, for now we only need these spaces to define the Morse-Smale-Witten chain complex.

¹²See ([BH04], Ch.6.4) and [Wis05].

¹³See ([Kos93], Ch.IV.3) for the first part, and ([PdM82], Ch.2.3) for the last part.

¹⁴For genericity results related to a Morse-Smale pair see ([BH04], p.160-164), ([Sch93], Ch.2.3) and ([Web06], Ch.3.1). For comparison see [Sma61], [Pal68] or [PS70].

In the sequel we fix a Morse-Smale function f . By transversality $W(p, q) = W^u(p) \pitchfork W^s(q)$ is an embedded submanifold of dimension $\lambda_p - \lambda_q$, and we obtain the following disjoint decompositions of M (as a set)

$$M = \bigcup_{p, q \in \text{Crit}(f)} W(p, q) = \bigcup_{p \in \text{Crit}(f)} W^u(p) = \bigcup_{p \in \text{Crit}(f)} W^s(p) \quad (1.1)$$

since all spaces are flow invariant (for the last two we of course only need the Morse property). Moreover, as a consequence of the λ -lemma we have

- 1) $(\text{Crit}(f), \leq)$ is a poset, with $p \geq q$ iff $W(p, q) \neq \emptyset$ (p is succeeded by q).
- 2) $\overline{W^u(p)} = \bigcup_{p \geq q} W^u(q)$ and $\overline{W^s(p)} = \bigcup_{q \geq p} W^s(q)$.
- 3) $\overline{W(p, q)} = \overline{W^u(p)} \cap \overline{W^s(q)} = \bigcup_{p \geq p' \geq q' \geq q} W(p', q')$.

Note that 3) together with the fact that f is Liapunov implies that there are only finitely many flow lines from p to q if $\dim W(p, q) = 1$, that is if the relative index $\mu(p, q) = \lambda_p - \lambda_q$ is equal to one. On $W(p, q)$ the flow φ is a free and proper \mathbb{R} -action, hence the orbit space $M(p, q) = W(p, q)/\mathbb{R}$ is a smooth $(\lambda_p - \lambda_q - 1)$ -manifold. In particular, $M(p, q)$ corresponds to the finite number of flow lines connecting p with q if $\mu(p, q) = 1$. We remark that $M(p, q)$ is in fact diffeomorphic to the transverse intersection $W(p, q)^t = W(p, q) \pitchfork f^{-1}(t)$ with $t \in [f(q), f(p)]$ a regular value, and that $M(p, q)$ may be replaced by $W(p, q)^t$ throughout the sequel.¹⁵

For each pair p, q of critical points with relative index one we recall how to define the boundary operator of the Morse-Smale-Witten chain complex by assigning a ± 1 to each of the finitely many elements of $M(p, q)$. To do so we first indicate how orientations on $W^u(q)$ and $W^u(p)$ induce an orientation on $W(p, q) = W^u(p) \pitchfork W^s(q)$ whenever this intersection is non empty.

Let $x \in W(p, q)$ and choose a linear subspace V in $T_x W^u(p)$ such that $T_x W^u(p) = T_x W(p, q) \oplus V$. Then V is a direct summand of $T_x W^s(q)$ in $T_x M$, and one can prove that $d\varphi_t(x)V \rightarrow T_q W^u(q)$ for $t \rightarrow \infty$ where the convergence is in the Grassmann bundle of λ_q -planes in TM . Now fix an orientation on $W^u(q)$, then for t large $d\varphi_t(x)V$, and therefore also V , has an orientation induced by the orientation on $T_q W^u(q)$. For a fixed orientation on $W^u(p)$ we orient $T_x W(p, q)$ by demanding that $T_x W^u(p) = T_x W(p, q) \oplus V$ is an oriented sum, this does not depend on the choice of V .¹⁶

¹⁵See section 2.2 and ([BH04], Ch.6) for details. One can also compare with ([Jos02], Ch.6.5).

¹⁶For details see [Abb]. This can be compared to ([GRS03], p.7) and ([Sal90], p.117).

Fix an arbitrary orientation on each unstable manifold and let $\mu(p, q) = 1$. We then associate to each $\mathbb{R} \cdot x \in M(p, q)$ a number $n(x) = +1$ if the orientation of the connected component of $W(p, q)$ corresponding to $\mathbb{R} \cdot x$ agree with the orientation given by $-\nabla f(x)$, and $n(x) = -1$ if not. Let $C_i(f, \mathbb{Z})$ be the free abelian group on $\text{Crit}_i(f)$ and define the homomorphism $\partial : C_i(f, \mathbb{Z}) \rightarrow C_{i-1}(f, \mathbb{Z})$ on a generator by

$$p \mapsto \sum_{\substack{q \in \text{Crit}_{i-1}(f) \\ x \in M(p, q)}} n(x)q = \sum_{q \in \text{Crit}_{i-1}(f)} n(p, q)q, \quad n(p, q) = \sum_{x \in M(p, q)} n(x) \quad (1.2)$$

and extend by linearity. We remark that $n(p, q)$ also can be defined as the intersection number of the unstable sphere $W^u(p) \pitchfork f^{-1}(t)$ and the stable sphere $W^s(q) \pitchfork f^{-1}(t)$ in $f^{-1}(t)$. The pair $(C_*(f, \mathbb{Z}), \partial)$ is called the Morse-Smale-Witten chain complex, and we have the following classical result:

1.6 Theorem. (Morse Homology Theorem)

The Morse-Smale-Witten chain complex is a chain complex whose homology is isomorphic to the singular homology $H(M, \mathbb{Z})$.

By the Universal Coefficient Theorem, \mathbb{Z} can be replaced by any commutative ring with unit.

There are several ways to prove theorem 1.6. To prove that $(C_*(f, \mathbb{Z}), \partial)$ is in fact a chain complex one can use techniques inspired by Floer. This approach has two main parts (1) a compactness result for $M(p, q)$ and (2) a gluing result. The compactness result describe “the ends” of $M(p, q)$ as broken orbits. We give a detailed description of this concept in section 2.3, for now just think of a broken orbit as an element in the product $M(p, a_1) \times M(a_1, a_2) \times \cdots \times M(a_k, q)$ or as a “concatenation” of flow lines. In the case $\mu(p, q) = 2$ each connected component of $M(p, q)$ is diffeomorphic to either S^1 or $]0, 1[$, since $M(p, q)$ is a one dimensional manifold without boundary. The compactness result then implies that to each end of $]0, 1[$ there correspond a unique pair $(x, y) \in M(p, a) \times M(a, q)$. Moreover, the gluing result implies that every pair (u, v) correspond precisely to one end of a component of $M(p, q)$. Since each component has two (or no) ends we may summarize the above as “pairs (x, y) of orbits come in pairs”. This observation together with an orientation argument implies that $\partial^2 = 0$. For details we refer to [Web06], [Sch93] and ([Jos02], Ch.6).

1.7 Remark: In the case of $\mathbb{Z}/2\mathbb{Z}$ coefficients we let $n(x) = 1$, hence there are

no orientation issues. Moreover, using (1.2) and rewriting we have

$$\partial^2 p = \sum_{\substack{q \in \text{Crit}_{\lambda_p - 2}(f) \\ (x, y) \in M(p, a) \times M(a, q)}} n(x)n(y)q$$

For fixed $q \in \text{Crit}_{\lambda_p - 2}(f)$ we know by the above that each coefficient is even, hence 0 mod 2. We can illustrate the above by

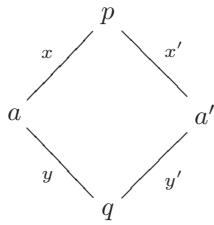
$$n(x)n(y) + n(x')n(y') \equiv 0 \pmod{2}$$

where the square represent a component of $W(p, q)$. ■

Finally for the isomorphism part of theorem 1.6 there are again several approaches. For a complete proof using the Conley index see ([BH04], Ch.7), and for a complete proof using methods from Floer homology see ([Sch93], Ch.4) or ([Jos02], Ch.6).

1.3.1 Appendix

For completeness we list below some of the main theorems of Morse theory. Fix a Morse function $f : M \rightarrow \mathbb{R}$ on a connected n -manifold M with $\partial M = \emptyset$, and let $S^I = S \cap f^{-1}(I)$ for any subset $S \subseteq M$ and $I \subseteq \mathbb{R}$. If $I =] - \infty, t]$ we also write $S^{\leq t}$ for S^I

The classical approach to Morse theory can very briefly be summarized in the following three results¹⁷

1.8 Theorem.

Assume $M^{[a, b]}$ is compact and $\text{Crit}(f) \cap M^{[a, b]} = \emptyset$. Then $M^{\leq a} \approx M^{\leq b}$, $M^{\leq a}$ is

¹⁷for proofs see e.g. ([BH04], Ch.3.2-3.3), ([Mil63], §3) or ([Hir94], Ch.6.2-6.3).

a deformation retract of $M^{\leq b}$, and there exists a diffeomorphism such that

$$\begin{array}{ccc} M^a \times [a, b] & \xrightarrow{\approx} & M^{[a, b]} \\ & \searrow \text{pr}_2 & \downarrow f \\ & & [a, b] \end{array}$$

commutes.

The retract and diffeomorphisms above are all defined via the flow of $\beta \nabla f / |\nabla f|^2$ with β a bump function. We remark that the vector field $\nabla f / |\nabla f|^2$ will play a central role in the forthcoming chapters.

1.9 Theorem.

Assume $M^{[a, b]}$ compact and $p = \text{Crit}(f) \cap M^{[a, b]}$ with $p \in \text{Crit}_i(f)$ non-degenerate. Then

$$M^{\leq b} \simeq M^{\leq a} \cup_{\varphi} e^i \quad \text{with } e^i \text{ an } i\text{-cell and } \varphi \text{ an attaching map}$$

and $M^{\leq a} \cup_{\varphi} e^i$ is a deformation retract of $M^{\leq b}$.

The above two theorems are the cornerstone in the following theorem which is the classical equivalent of theorem 1.6.

1.10 Theorem.

Assume that M^t compact for all t . Then $M \simeq X$ for a CW-complex X with one cell of dimension λ_p for every $p \in \text{Crit}(f)$.

The above theorems can also be formulated in terms of handlebodies, we briefly recall this approach.¹⁸ In a Morse chart (U, ψ) around $p \in \text{Crit}_i(f)$ write $f(x, y) = f(p) - |x|^2 + |y|^2$. A (n -dimensional) i -handle for p is the set $H_{\varepsilon}(p) = \{(x, y) \in U \mid |y|^2 \leq \varepsilon \text{ and } |x|^2 \leq |y|^2 + \varepsilon\}$. Let $f(p) = c$ then

$$W_{\varepsilon}^u(p) = W^u(p) \cap M^{[c-\varepsilon, c+\varepsilon]} \approx \mathbb{D}^i \quad (\text{the core of } H(\varepsilon))$$

$$W_{\varepsilon}^s(p) = W^s(p) \cap M^{[c-\varepsilon, c+\varepsilon]} \approx \mathbb{D}^{n-i} \quad (\text{the co-core of } H(\varepsilon))$$

$$H_{\varepsilon}(p) \approx \mathbb{D}^i \times \mathbb{D}^{n-i}$$

The (closed) disk \mathbb{D}^i corresponds to the i -cell appearing in theorem 1.10. The following classical results are versions of theorem 1.9 and 1.10 which keep track of the topological/differentiable structure.

¹⁸For details see e.g. ([Mat02], Ch.3), ([Fra82], p.7-11) or [Mil65].

1.11 Theorem.

With notation as above, we have the following homeomorphism

$$M^{\leq c+\varepsilon} \approx M^{\leq c-\varepsilon} \cup_{\varphi} H_{\varepsilon}(p) \quad \text{with } \varphi : \partial\mathbb{D}^i \times \mathbb{D}^{n-i} \rightarrow \partial M^{\leq c-\varepsilon} \text{ an attaching map}$$

and $M^{\leq c-\varepsilon} \cup_{\varphi} H_{\varepsilon}(p)$ is a strong deformation retract of $M^{\leq c+\varepsilon}$.

1.12 Theorem. (Handle decomposition theorem)

With notation as above, we have the following homeomorphism $M \approx \mathcal{H}$ for a handlebody

$$\mathcal{H} = \bigcup_{\varphi_p} H_{\varepsilon}(p) \approx \bigcup_{\varphi_p} \mathbb{D}^{\lambda_p} \times \mathbb{D}^{n-\lambda_p}$$

The homeomorphisms and attaching maps above are determined by the flow of a gradient-like vector field (for f). Moreover, if one “rounds the corners”¹⁹ of $M^{\leq c-\varepsilon} \cup_{\varphi} H_{\varepsilon}(p)$ then one can replace homeomorphism with diffeomorphism in the above results.

1.13 Remark: We recall the definition of a gradient-like vector fields. A gradient-like vector field for a Morse function f is an $X \in \mathcal{T}M$ such that $X(f) > 0$ away from all $p \in \text{Crit}(f)$, and X is in standard form near all p , that is for each p there is a chart such that locally f has the form given by the Morse lemma and X is the gradient of f with respect to the standard metric on \mathbb{R}^n . The existence of gradient-like vector fields are guaranteed since any Morse function give rise to such a vector field.²⁰ ■

¹⁹Or “straightening angles”, see ([Con79],Ch.I.3)

²⁰For details and more information see ([Mil65],p.20), ([Mat02],Ch.2), [Sma61], [Fra79] or [Fra82].

Chapter 2

The space of broken flow lines and related spaces

The main objective of this chapter is to study the topology and the relationship between the following four spaces: the space of connecting orbits, the moduli space of orbits, the space of height-parameterized flow lines and the space of broken flow lines. The first is a submanifold of M , the second a quotient space with the structure of a manifold, and the last two are function spaces. Notation and various relationships are summarized in the diagram and the table on page 25.

In this chapter we fix a Morse function $f : M \rightarrow \mathbb{R}$ on a closed n -manifold M and a Riemannian metric g on M such that the pair (f, g) is Morse-Smale. For details and notation we refer the reader to chapter 1 and references therein.

In section 2.1 we introduce the space of connecting orbits as a submanifold of M , and study its topological structure. In section 2.2 we define the moduli space of orbits via an \mathbb{R} -action on the space of connecting orbits. Moreover, relations between the moduli space of orbits and spaces derived from the space of connecting orbits are studied.

In section 2.3 we introduce the notion of a broken orbit and the concept of being compact up to broken orbits. This enables us to state a compactness theorem for the moduli space of orbits. We end the section with a remark concerning other versions of the compactness theorem, and with a comment regarding the

convergence of an orbit to a broken orbit which leads to a compactification of the moduli space of orbits. More precisely, it is shown that the moduli space can be embedded as a subspace, with compact closure, of a space having the Hausdorff topology.

In section 2.4 we define the space of height-parameterized flow lines by reparameterizing the flow lines of $-\nabla f$. We end by exploring the relationship between the space of height-parameterized flow lines and the previously defined spaces. In particular, it is shown that the space of height-parameterized flow lines has compact closure with respect to the compact open topology, that the space of height-parameterized flow lines is homeomorphic to the moduli space with the Hausdorff topology, and that this homeomorphism extends to the closures of these spaces in their respective topologies.

In section 2.5 we define the space of broken flow lines and study its topology together with its relations to the previously defined spaces. In particular, we show that the space of broken flow lines is compact and that the space of height-parameterized flow lines is open and dense in the space of broken flow lines.

Appendix 2.5.1 concerns the construction of a compact space which in the literature is described as a compactification of the moduli space of orbits into a smooth manifold with corners.

2.1 The space of connecting orbits

Let $\varphi : \mathbb{R} \times \mathbb{M} \rightarrow \mathbb{M}$; $(t, m) \mapsto \varphi(t, m) = t.m$ denote the flow of the complete vector field $-\nabla f$ and $C(\mathbb{R}, \mathbb{M})$ be the space of continuous functions $\mathbb{R} \rightarrow \mathbb{M}$ with the c -topology (compact-open topology). Since (\mathbb{M}, d) , with d the Riemannian distance function, is a (complete) metric space the notion of sequential convergence in $C(\mathbb{R}, \mathbb{M})$ is equivalent to the notion of uniform convergence on every compact subset, and by continuity of φ the map $\mathbb{M} \rightarrow C(\mathbb{R}, \mathbb{M})$; $m \mapsto \varphi_m$ ($t \mapsto t.m$) is continuous.¹

Let $p, q \in \text{Crit}(f)$, the space of connecting orbits from p to q is the transversal intersection $W(p, q) = W^u(p) \pitchfork W^s(q) \subset \mathbb{M}$, where $W^u(p)$ and $W^s(q)$ denote the unstable (resp. stable) manifolds at p (resp. q) w.r.t. $-\nabla f$ (or equivalently w.r.t. φ_t for $t > 0$ fixed). Hence $W(p, q)$ is an embedded $(\lambda_p - \lambda_q)$ -submanifold of \mathbb{M} without boundary, and consists of those $m \in \mathbb{M}$ for which $t.m \rightarrow q$ for $t \rightarrow \infty$ and $t.m \rightarrow p$ for $t \rightarrow -\infty$, so $W(p, q)$ is flow invariant. Moreover, if

¹Regarding the c -topology see e.g. ([Dug66], Ch.XII).

$W(p, q) \neq \emptyset$ then either $p \neq q$ and $\lambda_p > \lambda_q$ or $p = q$, in particular $p, q \in W(p, q)$ iff $p = q$ in which case $W(p, p) = \{p\}$.

For the height function on S^n we have $W(N, S) \approx \mathbb{R} \times S^{n-1} \simeq S^{n-1}$ where N and S denote the north and south pole respectively. In particular, $W(N, S)$ is (path) connected for $n > 1$. However, in general, $W(p, q)$ is not path connected, basically because neither of the two critical points lie in the manifold of connecting orbits. But since $W(p, q)$ is a manifold it is locally path connected, hence each connected component of $W(p, q)$ is path connected.

If $\text{codim}(W(p, q)) > 0$, then $W(p, q)$ has measure zero. Hence $M - W(p, q)$ is dense in M . If $\text{codim}W(p, q) = 0$ then $W(p, q)$ is open in M , indeed in this case $\lambda_p = n$ and $\lambda_q = 0$ so $W^u(p)$ and $W^s(q)$ are open in M by invariance of domain.

2.2 The moduli space of orbits

We now turn our attention to the moduli space of orbits. The flow φ induces an action of \mathbb{R} on $W(p, q)$ since $W(p, q)$ is flow invariant. Let $(t, m) \mapsto t.m$ denote the \mathbb{R} -action on $W(p, q)$ induced by φ and $\pi : W(p, q) \rightarrow W(p, q)/\mathbb{R}$ the open quotient map. This action is free (if $\mu(p, q) \geq 1$ which we assume) since f is Liapunov, and proper since if $m_i \rightarrow m$ and $t_i.m_i \rightarrow m'$ both converges in $W(p, q)$ then $\{t_i\}$ must contain a bounded subsequence $\{t_{i_j}\}$ since $\text{Crit}(f) \cap W(p, q) = \emptyset$.² So $\{t_{i_j}\}$ contains a convergent subsequence by the theorem of Bolzano-Weierstrass. Hence we give the orbit space $W(p, q)/\mathbb{R}$ the unique smooth structure of a $(\lambda_p - \lambda_q - 1)$ -manifold (without boundary) such that π is a smooth submersion. The quotient space $M(p, q) = W(p, q)/\mathbb{R}$ is called the moduli space of orbits from p to q .³

The relation between the space of connecting orbits and the moduli space of orbits can now be studied. In the sequel let $t \in [f(q), f(p)]$ be any regular value for f .

Consider the transversal intersection $W(p, q)^t = W(p, q) \pitchfork f^{-1}(t)$, an embedded $(\lambda_p - \lambda_q - 1)$ -submanifold of M . It follows that the free and proper \mathbb{R} -action $(u, m) \mapsto u.m$ on $W(p, q)$, induced by φ , induces a diffeomorphism $\mathbb{R} \times W(p, q)^t \xrightarrow{\cong} W(p, q)$; $(s, m) \mapsto \varphi(s, m)$. Moreover, this diffeomorphism is

²More precisely, for m' and each $a \in \text{Crit}(f)$ choose open neighborhoods $U_{m'}$ and U_a such that $U_{m'} \cap U = \emptyset$, with $U = \cup_a U_a$. Now if $\{t_i\}$ contains no bounded subsequence then $\{t_i.m_i\} \subset U$ for $i \geq N$ and some $N \in \mathbb{N}$. This contradicts $t_i.m_i \rightarrow m'$.

³For results and definitions see ([Lee03],p.216-223).

\mathbb{R} -equivariant w.r.t the smooth, free and proper \mathbb{R} -actions $(u, s, m) \mapsto u.(s, m) = (u + s, m)$ and $(u, m) \mapsto u.m$, and it follows that it induces a homeomorphism $(\mathbb{R} \times W(p, q)^t)/\mathbb{R} \xrightarrow{\cong} M(p, q)$ on the corresponding orbit spaces. As above give $(\mathbb{R} \times W(p, q)^t)/\mathbb{R}$ the unique smooth structure of a $(\lambda_p - \lambda_p - 1)$ -manifold such that the open quotient map π' is a smooth submersion, then the induced homeomorphism becomes a diffeomorphism. Moreover, the smooth projection $\mathbb{R} \times W(p, q)^t \rightarrow W(p, q)^t$ is a homotopy equivalence with homotopy inverse $m \mapsto (t', m)$ for any fixed t' (and homotopy $(u, m, s) \mapsto (s(u - t') + t', m)$), and since the projection is constant on each fiber of the surjective submersion π' , it induces a unique smooth map $(\mathbb{R} \times W(p, q)^t)/\mathbb{R} \rightarrow W(p, q)^t$ which can be seen to be a diffeomorphism. In summary we have the following commutative diagram⁴

$$\begin{array}{ccc}
 \mathbb{R} \times W(p, q)^t & \xrightarrow{\cong} & W(p, q) \\
 \swarrow \cong & \downarrow \pi' & \downarrow \pi \\
 W(p, q)^t & \xleftarrow[\cong]{} (\mathbb{R} \times W(p, q)^t)/\mathbb{R} \xrightarrow[\cong]{} & M(p, q)
 \end{array} \tag{2.1}$$

The identification $W(p, q)^t \approx M(p, q)$ given by $m \leftrightarrow \mathbb{R}.m$ will be used frequently throughout. That is, a class $\mathbb{R}.m' = [m'] = \pi(m') \in M(p, q)$ will be identified with the representative $m = \pi^{-1}([m']) \cap f^{-1}(t) = \pi^{-1}([m'])^t \in W(p, q)^t$.

2.3 Broken orbits and convergence

In the sequel we will introduce the notion of being compact up to broken orbits, which allows us to describe the limit of any sequence in the moduli space. To do so we need some terminology, see also figure 2.1. Let $\mathbf{b} = \{b_0, b_1, \dots, b_l\}$ denote a finite sequence with $l \geq 1$ in the poset $(\text{Crit}(f), \leq)$. Then \mathbf{b} is called a chain if $b_i \leq b_{i+1}$, and an inverse chain if $b_i \geq b_{i+1}$. In any case we let $b_0 = \text{sou}(\mathbf{b})$, $b_l = \text{tar}(\mathbf{b})$ and $l(\mathbf{b}) = l$ which is called the source, the target, and the order of \mathbf{b} , respectively.⁵ A chain \mathbf{b} of order l is called strict if $b_i < b_{i+1}$, trivial if $l = 1$ and degenerate if equality occurs i.e. $b_i = b_{i+1}$. By replacing $<$ with $>$

⁴See ([Let03],Ch.3.2) and ([Lee03],p.170) for details. One can also compare with ([Sch93],Ch.2.4.1).

⁵Note that, for a chain the terminology source and target are “backwards” when compared to the orientation of the flow lines of $-\nabla f$. However, the terminology is in agreement with the orientation of the flow lines of ∇f (and $\nabla f/|\nabla f|^2$), and such flow lines will be used throughout (see also remark 2.6).

in the strict condition, the above terminology applies to inverse chains as well. Note that an (inverse) chain would be strict if the word sequence was replaced by subset. Moreover, we let $\mathbf{M}(\mathbf{b}) = \prod_{j=1}^l \mathbf{M}(b_{j-1}, b_j)$ and write $\bar{x} \in \mathbf{M}(\mathbf{b})$ with $\bar{x} = (x_1, \dots, x_l)$ and $x_j \in \mathbf{M}(b_{j-1}, b_j)$ a connecting orbit from b_{j-1} to b_j . The element \bar{x} is called a broken orbit (from $\text{sou}(\mathbf{b})$ to $\text{tar}(\mathbf{b})$ of order $l = l(\mathbf{b})$).

Now let $U_\varepsilon(S)$ denote the open ε -neighborhood of a subset $S \subset \mathbf{M}$ with respect to the Riemannian distance d , i.e. $U_\varepsilon(S) = \{m \in \mathbf{M} \mid \varepsilon > d(m, S) = \inf_{s \in S} d(m, s)\}$ or equivalently $U_\varepsilon(S) = \bigcup_{s \in S} B_\varepsilon(s)$ with $B_\varepsilon(s) = \{m \in \mathbf{M} \mid d(s, m) < \varepsilon\}$. A subset $K \subseteq \mathbf{M}(p, q)$ is called compact up to broken orbits of order l if for every sequence $\{m_k\} \subseteq K$ there exists a subsequence $\{m_n\}$, a strict inverse chain \mathbf{b} of order $l' \leq l$ with $p = \text{sou}(\mathbf{b})$ and $q = \text{tar}(\mathbf{b})$, and a broken orbit $\bar{x} \in \mathbf{M}(\mathbf{b})$ such that for all $\varepsilon > 0$ there exists $N \in \mathbb{N}$ with $\mathbb{R}.m_n \subset U_\varepsilon(\mathbb{R}.x_1 \cup \dots \cup \mathbb{R}.x_{l'})$ whenever $n \geq N$. In this situation we write $m_n \rightarrow \bar{x}$ as $n \rightarrow \infty$ and say that m_n converges to the broken orbit \bar{x} of order l' .

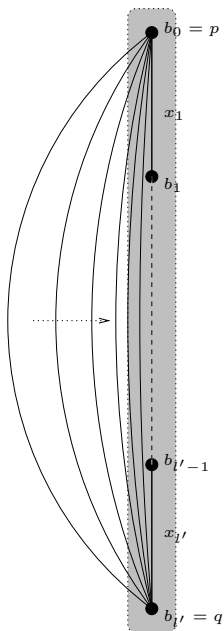

Figure 2.1: A sequence of orbits converging to a broken orbit of order l' , where the shaded area represents an ε -neighborhood of the broken orbit.

2.1 Theorem.

The moduli space of connecting orbits $M(p, q)$ is compact up to broken orbits of order at most $\mu(p, q) = \lambda_p - \lambda_q$.

In ([Web06], Ch.3.2) the above compactness theorem is stated (and proven) with $M(p, q)$ replaced by $W(p, q)^t$, but as we have seen $W(p, q)^t \approx M(p, q)$. Note that if $\mu(p, q) = 1$ the compactness theorem says that $M(p, q)$ is compact.

2.2 Remark: In [AB95] the orbit space $M(p, q)$ is defined as above, but there $M(p, q)$ is identified with “a set of flow lines”. The explanation regarding this set and the identification is unfortunately nowhere to be found. Presumably this “set of flow lines” is defined as follows. Let $\mathcal{M}(p, q)$ denote the set of all parameterized flow lines from p to q i.e. $\mathcal{M}(p, q) = \{\varphi_m\}_{m \in W(p, q)}$. Since $W(p, q) \rightarrow \mathcal{M}(p, q)$; $m \mapsto \varphi_m$ is a bijective correspondence, with inverse $\gamma \mapsto \gamma(0)$, we may give $\mathcal{M}(p, q)$ the manifold structure of $W(p, q)$. In this setting the smooth, free and proper \mathbb{R} -action on $W(p, q)$ induces a smooth, free and proper \mathbb{R} -action on $\mathcal{M}(p, q)$ by $(t, \gamma) \mapsto t.\gamma = \gamma(t + \cdot)$. As above we get a diffeomorphism on the orbit spaces $M(p, q) \xrightarrow{\cong} \mathcal{M}(p, q)/\mathbb{R}$; $\mathbb{R}.m \mapsto \mathbb{R}.\varphi_m$, hence the “flow model” of $M(p, q)$ could be $\mathcal{M}(p, q)/\mathbb{R}$. With this in mind one could consult ([AB95], Ch.2) for a proof of the compactness theorem. For other versions of theorem 2.1 see ([Sch93], Ch.2.4.2) or ([Jos02], Ch.6.4).

Note that if we only needed a topological “flow model” of $M(p, q)$ one could view $\mathcal{M}(p, q)$ as a subspace of $C(\mathbb{R}, M)$ with the c -topology. Indeed this model (of $W(p, q)$) is homeomorphic to the above differentiable model, and we may proceed as above to obtain a homeomorphism $M(p, q) \xrightarrow{\cong} \mathcal{M}(p, q)/\mathbb{R}$. ■

2.3 Remark: We will now discuss the above convergence with respect to Hausdorff topology. Let \mathcal{CM} denote the set of nonempty closed (hence compact) subspaces of M . It is well known (see e.g. ([AT04], Ch.4.4), ([BBI01], Ch.7.3) or ([BH99], Ch.I.5)) that (\mathcal{CM}, d_H) is a compact (since M is compact) metric space with d_H the Hausdorff distance, i.e. $d_H(A, B) = \inf\{\varepsilon \in \mathbb{R}_+ \mid A \subset U_\varepsilon(B) \text{ and } B \subset U_\varepsilon(A)\}$ or equivalently $d_H(A, B) = \sup\{\sup_{a \in A} d(a, B), \sup_{b \in B} d(b, A)\}$. Note that $d(A, B) < k$ iff $A \subset U_k(B)$ and $B \subset U_k(A)$.

For $p, q \in \text{Crit}(f)$ and each $m \in W(p, q)^t$ let $l(m) = \mathbb{R}.m \cup \{p, q\}$, and define the subspace $M'(p, q) \subset \mathcal{CM}$ by $M'(p, q) = \{l \in \mathcal{CM} \mid l = l(m), m \in W(p, q)^t\}$. Note that with the identification $W(p, q)^t \approx M(p, q)$; $m \leftrightarrow \mathbb{R}.m$ the sets $W(p, q)^t$ and $M'(p, q)$ are equal (in **Set**), in fact this is true even as spaces i.e. the correspondence $m \rightarrow l(m)$ defines a homeomorphism. To show this recall that (lemma

5.32 in ([BH99],p.71)); $l_n \rightarrow l$ in \mathcal{CM} iff (1) for all $x \in l$ there exists a sequence $x_n \in l_n$ such that $x_n \rightarrow x$ in \mathbb{M} , and (2) every sequence $x_n \in l_n$ has a convergent subsequence whose limit point is an element of l .

Now let $l_n = l(m_n)$, $l = l(m)$ and assume that $m_n \rightarrow m$ in $W(p, q)^t$. By (1) and (2) above we will show that $l_n \rightarrow l$, hence $m \mapsto l(m)$ is continuous. If $x \in l - \{p, q\}$, then there exists $s \in \mathbb{R}$ such that $x = s.m$ so $x_n \rightarrow x$ where $x_n = s.m_n \in l_n$. If $x = p$ (resp. $x = q$) let $x_n = p$ (resp. $x_n = q$), this proves (1) above. Moreover, let $x_n \in l_n$ be any sequence. Since \mathbb{M} is compact this sequence has a convergent subsequence, also denoted x_n . For each n there exists $s_n \in \mathbb{R}$ such that $x_n = s_n.m_n$ with either $s_n \rightarrow s$ implying that $x_n \rightarrow s.m \in l$ or $s_n \rightarrow \pm\infty$ implying that x_n converges to p or q according to the sign of ∞ (note that this is the only way s_n can diverge since x_n is convergent and m_n converges to a non critical point). This proves (2) above so the map $\mathbb{M}(p, q) \rightarrow M'(p, q)$; $m \mapsto l(m)$ is continuous. To prove that the inverse $l = l(m) \mapsto m$ is continuous assume that $l_n \rightarrow l$. Then there exists $m_n, m \in W(p, q)^t$ such that $l_n = l(m_n)$ and $l = l(m)$ so we have to prove that $m_n \rightarrow m$. By (1) above there exists a sequence $x_n \rightarrow m$ in \mathbb{M} , but since $x_n \in l_n \subset W(p, q) \cup \{p, q\}$ and $m \in W(p, q)^t$ is not a critical point we may assume that $\{x_n\} \subset W(p, q)$. It follows that $\pi(x_n) \rightarrow \pi(m)$ where π is the quotient map $W(p, q) \rightarrow \mathbb{M}(p, q)$. Hence $m_n \rightarrow m$ by the identification $W(p, q)^t \approx \mathbb{M}(p, q)$; $m \leftrightarrow \pi(m) = [m]$.

By a broken trajectory from b_0 to b_k of order k we understand an element $l \in \mathcal{CM}$ of the form $\{b_0\} \cup \mathbb{R}.x_1 \cup \{b_1\} \cup \mathbb{R}.x_2 \cup \dots \cup \{b_{k-1}\} \cup \mathbb{R}.x_k \cup \{b_k\}$ where $\mathbf{b} = \{b_0, b_1, \dots, b_k\}$ is a strict inverse chain and $\bar{x} = ([x_1], [x_2], \dots, [x_k]) \in \mathbb{M}(\mathbf{b})$ a broken orbit.

We will now examine the cluster points of $M'(p, q)$. Let l_n be a sequence in $M'(p, q)$; by theorem 2.1 we have that for all $\varepsilon > 0$ there exists $N \in \mathbb{N}$, a subsequence $l_{n(i)}$ of l_n and some broken trajectory l from p to q of order at most $\mu(p, q)$ such that $l_{n(i)} \subset U_\varepsilon(l)$ for $n(i) \geq N$. To show that $l_{n(i)}$ converges to l in \mathcal{CM} we need to show that $l \subset U_\varepsilon(l_{n(i)})$ for $n(i)$ large, or equivalently (1) above, since $l_{n(i)} \subset U_\varepsilon(l) = \bigcup_{x \in l} B_\varepsilon(x)$ implies that for all $\varepsilon > 0$ there exists $N \in \mathbb{N}$ such that for all $x_{n(i)} \in l_{n(i)}$ there exists $x \in l$ with $x_{n(i)} \in B_\varepsilon(x)$ whenever $n(i) \geq N$ i.e (2) holds. Therefore let $x \in l$, $f(x) = t$ and define the sequence $x_{n(i)} \in l_{n(i)}$ by $x_{n(i)} = l_{n(i)} \cap f^{-1}(t)$. By (2) above $x_{n(i)} \rightarrow x'$ but $f(x_{n(i)}) = t$ so $f(x') = t = f(x)$ implying that $x' = x$. Hence $l_{n(i)} \rightarrow l$ so any sequence in $M'(p, q)$ has a convergent subsequence (which we already knew since \mathcal{CM} is compact) with cluster point a broken trajectory from p to q of order at most $\mu(p, q)$. So the closure $\overline{M'(p, q)}$, which is compact, consists of $M'(p, q)$

and all such broken trajectories. It follows that $\overline{M'(p, q)}$ is a compactification of $M(p, q)$, so in summary we have proven:

2.4 Claim.

With notation as above. The maps $W(p, q)^t \rightarrow M'(p, q); m \mapsto l(m)$ and $M(p, q) \xrightarrow{\text{closure}} \overline{M'(p, q)}; [m] \mapsto l(m)$ are both homeomorphisms. Moreover, the closure $\overline{M'(p, q)}$, which is compact, is a compactification of both $W(p, q)^t$ and $M(p, q)$.

The above should be compared to appendix 2.5.1. Moreover the approach in this paragraph can also be found in ([Abb], Ch.1.6) or [Hur00]. ■

2.4 The space of height-parameterized flow lines

We now proceed to the function spaces mentioned in the introduction of this chapter. Unless otherwise stated all sets of maps will have the c -topology, and we refer to ([Bre93], Ch.VII.2) or ([Dug66], Ch.XII) for standard results in this realm⁶. We start by reparameterizing the flow lines φ_m in the following way. For $m \in \tilde{M} = M - \text{Crit}(f)$, with say $m \in W(p, q)$, define the (strictly decreasing) diffeomorphism $h_m : \mathbb{R} \rightarrow]f(q), f(p)[$ by $t \mapsto f(\varphi_m(t))$ and the “reverse height-parameterization” of φ_m by $\tilde{\eta}_m :]f(q), f(p)[\rightarrow M; t \mapsto \tilde{\eta}_m(t) = \varphi_m(h_m^{-1}(t))$, so $f \circ \tilde{\eta}_m = \mathbf{1}$ where $\mathbf{1}$ denotes the identity. Note that h_m depends continuously on $m \in W(p, q)$ since $m \mapsto \varphi_m$ and left composition with f ($\varphi_m \mapsto f \circ \varphi_m$) are continuous. To see this for $m \mapsto \tilde{\eta}_m$ we need:

2.5 Claim.

Let $A \subset C(X, Y) \times C(Y, X)$ be the subspace $\{(g, k) \mid g \circ k = \mathbf{1} \text{ and } k \circ g = \mathbf{1}\}$, $A_1 = \text{pr}_1(A) \subset C(X, Y)$ and $A_2 = \text{pr}_2(A) \subset C(Y, X)$. Then $\iota : A_1 \rightarrow A_2; g \mapsto g^{-1}$ is a homeomorphism (in the c -topology).

Proof:

Since the diagram

$$\begin{array}{ccc} A & \xrightarrow{\text{pr}_2} & A_2 \\ \text{pr}_1 \downarrow & \nearrow \iota & \\ A_1 & & \end{array}$$

⁶For comparison see ([Irw01], App.B.II) or ([Hir94], Ch.2).

commutes and pr_1 (resp. pr_2) is an identification map it follows that ι (resp. the inverse $A_2 \rightarrow A_1$; $k \mapsto k^{-1}$ of ι) is continuous, hence proving the claim. \square

Hence $\tilde{\eta}_m$ depends continuously on $m \in \mathbb{W}(p, q)$ since the maps $h_m \mapsto h_m^{-1}$ and $(\varphi_m, h_m^{-1}) \mapsto \varphi_m \circ h_m^{-1}$ are continuous. Now define the map

$$\tilde{\eta} :]f(q), f(p)[\times \mathbb{W}(p, q) \rightarrow \mathbb{W}(p, q); (t, m) \mapsto \tilde{\eta}(t, m) = \tilde{\eta}_m(t)$$

which is continuous since (1) the map $m \mapsto \tilde{\eta}_m$ is continuous by the above, and (2) the map $t \mapsto \tilde{\eta}_m(t)$ is (smooth hence) continuous for each $m \in \mathbb{W}(p, q)$. Since this construction applies for any $p, q \in \text{Crit}(f)$ (with $p \neq q$ and $\mathbb{W}(p, q) \neq \emptyset$) and the domains of the various maps are disjoint (as subset of $\mathbb{R} \times \tilde{\mathbb{M}}$) we let, by abuse of notation, $\tilde{\eta}$ denote the union of all such maps i.e.

$$\begin{aligned} \tilde{\eta} : \tilde{D} &\rightarrow \tilde{\mathbb{M}}; (t, m) \mapsto \tilde{\eta}(t, m) = \tilde{\eta}_m(t) \\ \tilde{D} &= \{(t, m) \in \mathbb{R} \times \tilde{\mathbb{M}} \mid m \in \mathbb{W}(p, q) \text{ and } t \in]f(q), f(p)[\} \\ &\text{with } (f(m), m) \in \tilde{D} \text{ for all } m \in \tilde{\mathbb{M}} \end{aligned}$$

Now let X be the vector field $X = \nabla f / |\nabla f|^2 \in \mathcal{T}\tilde{\mathbb{M}}$ then it is easy to see that $\frac{d}{dt}\tilde{\eta}_m = X(\tilde{\eta}_m)$ for all $m \in \tilde{\mathbb{M}}$, hence $\tilde{\eta}_m$ is an integral curve of X for each $m \in \tilde{\mathbb{M}}$. Note however that $\tilde{\eta}(t + s, m) \neq \tilde{\eta}(t, \tilde{\eta}(s, m))$ since both points lie on the orbit $l = \mathbb{R}.m$ but $\tilde{\eta}(t + s, m) = l^{t+s}$ and $\tilde{\eta}(t, \tilde{\eta}(s, m)) = l^t$. In fact $\tilde{\eta}(t, \cdot) : l = \mathbb{R}.m \mapsto l^t$ so it is constant on orbits of φ (see also remark 2.6, claim 2.9, the paragraph above this claim, and remark 2.10).

Moreover, since $\lim_{t \rightarrow \pm\infty} \varphi_m(t) \in \text{Crit}(f)$ each $\tilde{\eta}_m$ may be extended to a continuous curve $\eta_m : [f(q), f(p)] \rightarrow \mathbb{M}$ with $\eta_m(f(q)) = q$ and $\eta_m(f(p)) = p$. So we obtain a continuous map $\eta : [f(q), f(p)] \times \mathbb{W}(p, q) \rightarrow \mathbb{M}$; $(t, m) \mapsto \eta(t, m)$ with $\eta = \tilde{\eta}$ on $\text{dom}(\tilde{\eta})$. If $p = q$ we define η to be the trivial continuous map $[f(p)] \times \{p\} \rightarrow \{p\}$, and as above we let, again by abuse of notation, η denote the union of all such maps i.e.

$$\begin{aligned} \eta : D &\rightarrow \mathbb{M}; (t, m) \mapsto \eta(t, m) = \eta_m(t) \\ D &= \{(t, m) \in \mathbb{R} \times \mathbb{M} \mid m \in \mathbb{W}(p, q) \text{ and } t \in [f(q), f(p)]\} \end{aligned}$$

with $\eta = \tilde{\eta}$ on \tilde{D} . The curves $t \mapsto \eta_m(t)$ are called height-parameterized flow lines, and when m is of no concern we sometimes write γ (or simply η) for these curves.

2.6 Remark: The η_m 's are "reverse height-parameterizations" of the φ_m 's, i.e. they start at $q = \eta(f(q))$ and end at $p = \eta(f(p))$. This is a reflection of the fact

that these flow lines are “height-parameterized” flow lines with respect to $-f$ i.e. for ∇f . Moreover, it is not difficult to see that the integral ξ of X is given by $D' \rightarrow \tilde{M}$; $(t, m) \mapsto \xi(t, m) = \tilde{\eta}(t + f(m), m)$ where $D' = \{(t, m) \in \mathbb{R} \times M \mid m \in W(p, q) \text{ and } t \in]f(q) - f(m), f(p) - f(m)[\}$. Hence ξ and $\tilde{\eta}$ are related by $\xi = \tilde{\eta} \circ (\alpha, \text{pr}_2)$ where α is the continuous map $D' \rightarrow [f(q), f(p)]$; $(t, m) \rightarrow s = \text{pr}_1(t, m) + f(\text{pr}_2(t, m)) = t + f(m)$.⁷ ■

Let $C([f(q), f(p)], M)$ have the c -topology, and note that it is second countable and regular.⁸ We are now in a position to describe the remaining two (function) spaces. With notation as above let $M(q, p)$ be the subspace of $C([f(q), f(p)], M)$ defined by

$$M(q, p) = \{\eta_m \in C([f(q), f(p)], M) \mid m \in W(p, q)\}$$

which of course is second countable and regular. Elements of this space are curves η_m starting at q and ending at p with $\text{im}(\eta_m) - \{q, p\} = l = \text{im}(\varphi_{m'})$ for $m' \in l$, but η_m and $\varphi_{m'}$ run through l in opposite directions as noted in remark 2.6 above. The space $M(q, p)$ is called the space of height-parameterized flow lines from q to p , and elements are called either height-parameterized flow lines, M -maps or by abuse of language flow lines. It might be confusing that the elements of $M(q, p)$ and $\{\varphi_m\}_{m \in W(p, q)}$ have opposite orientation. This could be fixed if we from the start had considered the gradient ∇f instead of $-\nabla f$, but in that case the dimension of the unstable and stable manifold would be interchanged which is in conflict with standard Morse theory. Another way of dealing with the above problem is to define the elements of $M(q, p)$ as curves $t \mapsto \eta_m(f(p) + f(q) - t)$, i.e. they run through the trajectories of $\{\eta_m\}_{m \in W(p, q)}$ in the same direction as $\{\varphi_m\}_{m \in W(p, q)}$, but then $f(q)$ (resp. $f(p)$) is mapped to p (resp. q), which is confusing. Moreover, the question of which parameterization (or dynamical system) we consider is more a technical detail than a real issue, hence we are content with the above setup.⁹

2.7 Remark: Let $J = [f(q), f(p)]$ and note that the c -topology on $C(J, M)$ (and hence on $M(q, p)$) is induced by the uniform metric $d_\infty(\gamma, \gamma') = \sup_{t \in J} d(\gamma(t), \gamma'(t))$ with d the Riemannian distance, see e.g. ([Bre93], Ch.VII.2). In particular $M(q, p)$ is perfectly normal and paracompact (see ([Dug66], p.186)).

Moreover $M(q, p)$ is in fact a subspace of $C'^\infty(J, M) \subset C(J, M)$ the space of

⁷See ([Let03], p.15-16).

⁸See ([Dug66], p.258.265)

⁹One can compare with ([Sch93], Ch.2.4.1).

piecewise smooth curves (or even more precisely, a subspace of $\Omega(M, q, p) \subset C'^\infty(J, M)$ the space of piecewise smooth curves from q to p).

In the following three paragraphs we will mention some facts related to the above spaces. This is for comparison only and is somewhat out of context, so if the reader desires these paragraphs can be skipped. For details we refer to ([Kah80], Ch.7), ([Kli95], Ch.2.3) or ([Jos98], Ch.5.4). Also see ([Mil63], §16+§17).

Let $I \subset \mathbb{R}$ denote a compact interval, $\langle \cdot | \cdot \rangle$ the standard inner product on \mathbb{R}^n and $|\cdot|$ the induced norm. (1) the completion of the (real) vector space $C'^\infty(I, \mathbb{R}^n)$ w.r.t. the norm $|c|_\infty = \sup_t |c(t)|$ is $C(I, \mathbb{R}^n)$, hence $(C(I, \mathbb{R}^n), |\cdot|_\infty)$ is a Banach space. Since there exists curves in $C(I, \mathbb{R}^n)$ which are nowhere differentiable, the length $L(c) = \int_I |\dot{c}(t)| dt$ and energy $2E(c) = \int_I \langle \dot{c}(t) | \dot{c}(t) \rangle dt = \int_I |\dot{c}(t)|^2 dt$ functionals do not possess extensions (even as set maps) to the completion $(C(I, \mathbb{R}^n), |\cdot|_\infty)$ of $(C'^\infty(I, \mathbb{R}^n), |\cdot|_\infty)$. (2) therefore let $|\cdot|_1$ be the $H^{1,2}$ -norm induced by the inner product $\langle c|u \rangle_1 = \langle c|u \rangle_0 + \langle \dot{c}|\dot{u} \rangle_0$ where $\langle c|u \rangle_0 = \int_I \langle c(t)|u(t) \rangle dt$ (also an inner product), and $H^1(I, \mathbb{R}^n) = H^{1,2}(I, \mathbb{R}^n)$ the completion of $C'^\infty(I, \mathbb{R}^n)$ w.r.t. $|\cdot|_1$. Hence $(H^1(I, \mathbb{R}^n), \langle \cdot | \cdot \rangle_1)$ is a Hilbert space. We then have that $|c|_\infty \leq |c|_1$ i.e. the inclusion $H^1(I, \mathbb{R}^n) \hookrightarrow C(I, \mathbb{R}^n)$ is continuous, and there exists continuous extensions of the length L and energy E to $H^1(I, \mathbb{R}^n)$.

The above can be “extended” from \mathbb{R}^n to a complete smooth manifold $(M, g = \langle \cdot | \cdot \rangle, \nabla, d)$ where $\langle \cdot | \cdot \rangle$ is a Riemannian metric (with $|\cdot|$ the induced norm), ∇ is the Levi-Civita derivation and d is the Riemannian distance. Let $C'^\infty(I, M)$ be the set of piecewise smooth curves and $H^1(I, M)$ the set of curves c such that $\psi \circ c \in H^1(I', \mathbb{R}^n)$ where (M', ψ) is a chart and $I' = c^{-1}(M')$. Let $(C(I, M), \tau)$ be the space of continuous curves with the compact open topology τ . The topology τ_∞ on the (complete) metric space $(C(I, M), d_\infty)$, where $d_\infty(c, u) = \sup_t d(c(t), u(t))$, agrees with τ and we have the following. There are (set) inclusions $C'^\infty(I, M) \hookrightarrow H^1(I, M) \hookrightarrow C(I, M)$ and $C'^\infty(I, M)$ is a dense subspace of $(C(I, M), d_\infty)$ (hence also of $H^1(I, M)$). Now as set maps the length $L(c) = \int_I |\dot{c}(t)| dt$ and energy $2E(c) = \int_I |\dot{c}(t)|^2 dt$ are well defined on $H^1(I, M)$, but τ_∞ is not fine enough to yield continuity of these maps. Guided by (2) above we therefore proceed by letting $C'^\infty(c^*TM)$ denote the vector space of piecewise smooth vector fields along $c \in C'^\infty(I, M)$ and for $\xi, \rho \in C'^\infty(c^*TM)$ define the norm $|\xi|_\infty = \sup_t |\xi(t)|$ and inner product $\langle \xi|\rho \rangle_1 = \langle \xi|\rho \rangle_0 + \langle \nabla \xi | \nabla \rho \rangle_0$ with $\langle \xi|\rho \rangle_0 = \int_I \langle \xi(t)|\rho(t) \rangle dt$ (also an inner product). The completion of $C'^\infty(c^*TM)$ w.r.t. $|\cdot|_\infty$ (resp. $|\cdot|_1 = \langle \cdot | \cdot \rangle_1$) is denoted $C(c^*TM)$ (resp. $H^1(c^*TM)$) and we have toplinear isomorphisms $(C(c^*TM), |\cdot|_\infty) \approx (C(I, \mathbb{R}^n), |\cdot|_\infty)$ and $(H^1(c^*TM), |\cdot|_1) \approx (H^1(I, \mathbb{R}^n), |\cdot|_1)$. Moreover, $|\xi|_\infty \leq |\xi|_1$ i.e. the inclusion

$H^1(c^*TM) \hookrightarrow C(c^*TM)$ is continuous.

2.8 Theorem.

(1) $C'^\infty(I, \mathbf{M})$ can be given the structure of a smooth Banach manifold modeled on $(C(c^*TM), |\cdot|_\infty)$. Moreover, the manifold topology agrees with $\tau_\infty = \tau$. ([Kah80], Ch.7 Theorem 7.2)

(2) $H^1(I, \mathbf{M})$ can be given the structure of a smooth Hilbert manifold modeled on $(H^1(c^*TM), |\cdot|_1) = T_c H^1(I, \mathbf{M})$, which has a Riemannian metric that coincides with $\langle \cdot, \cdot \rangle_1$. Moreover, $d_1(c, u) = d_\infty(c, u) + (\int_I (|\dot{c}(t)| - |\dot{u}(t)|)^2)^{1/2}$ is the distance on $H^1(I, \mathbf{M})$ derived from $\langle \cdot, \cdot \rangle_1$ which generates a topology τ_1 that agrees with the manifold topology. ([Kli95], Ch.2.3 Theorem 2.3.12(19))

Since $d_\infty \leq d_1$ (or $|\cdot|_\infty \leq |\cdot|_1$) we have that $\tau_\infty \subset \tau_1$ i.e. τ_1 is finer than τ_∞ so the inclusion $(H^1(I, \mathbf{M}), \tau_1) \hookrightarrow (H^1(I, \mathbf{M}), \tau_\infty)$ is continuous, and any continuous map on $(H^1(I, \mathbf{M}), \tau_\infty)$ is also continuous on $(H^1(I, \mathbf{M}), \tau_1)$. Moreover, the length L and energy E are continuous on $(H^1(I, \mathbf{M}), \tau_1)$ ([Jos98], Ch.5.4 Lemma 5.4.1), and the inclusion $(\Omega(\mathbf{M}, q, p), \tau_1) \hookrightarrow (\Omega(\mathbf{M}, q, p), \tau_\infty)$ is a homotopy equivalence ([Mil63], §17 Theorem 17.1). Since $(\Omega(\mathbf{M}, q, p), \tau_\infty)$ has the c -topology, theorem 3 in [Mil59] applies (with $\mathbf{A} = (\mathbf{M}, q, p)$ and $\mathbf{C} = (I = [a, b], a, b)$) so $(\Omega(\mathbf{M}, q, p), \tau_\infty)$, and hence $(\Omega(\mathbf{M}, q, p), \tau_1)$, has the homotopy type of a CW-complex. In contrast $(C(I, \mathbf{M}), \tau_\infty)$ is an absolute neighborhood retract ([Kur35], p.284) hence has the homotopy type of a finite CW-complex ([Mil59], Theorem 1(d)). See also ([Bor67], Ch.IV.5) and [Jac52]. \blacksquare

We now turn to the study of the relationship between the moduli space and the space of height-parameterized flow lines. As noted above, if $m \in \mathbf{W}(p, q)$ and $m' \in \text{Orbit}(\varphi_m)$ then $\eta_m = \eta_{m'}$, hence $M(q, p)$ could just as well be defined as $M(q, p) = \{\eta_m \in C([f(q), f(p)], \mathbf{M}) \mid m \in \mathbf{W}(p, q)^t\}$, reflecting the fact that there is a kind of quotient structure on $M(q, p)$. Indeed we have that;

2.9 Claim.

The evaluation map $e_t : M(q, p) \rightarrow \mathbf{W}(p, q)^t \approx M(p, q)$ at $t \in]f(q), f(p)[$ is a homeomorphism.

Proof:

Let $\mathbf{W}(p, q)^t \rightarrow M(q, p)$; $m \mapsto \eta_m$ be the induced partial map of η and note that $\eta_m(t) = m$ since $t = f(m)$. It follows that this map is the inverse of e_t , hence proving the claim since both maps are continuous.¹⁰ \square

¹⁰This result can properly be extended to the smooth case, see ([Irw01], App.B.II) or ([AR67], Ch.2).

2.10 Remark: In this remark we prove that $\eta :]f(q), f(p)[\times W(q, p)^t \rightarrow W(p, q)$ is smooth. Define $\theta : W(p, q) \rightarrow]f(q), f(p)[\times M(p, q)$ by $\theta = (f, \pi)$. Hence θ is smooth and the diagram

$$\begin{array}{ccc}]f(q), f(p)[\times W(q, p)^t & \xrightarrow{\eta} & W(p, q) \\ \mathbf{1} \times \psi \downarrow & \swarrow \theta & \\]f(q), f(p)[\times M(p, q) & & \end{array}$$

commutes, with ψ the diffeomorphism $m \leftrightarrow \mathbb{R}.m$. Since π is a submersion and $\nabla f \neq 0$ on $W(p, q)$ we may apply the inverse function theorem to conclude that θ^{-1} exists and is smooth. Hence η is smooth, since it factors through smooth maps by the above diagram. ■

Because of the claim above $M(p, q)$ is sometimes referred to as the moduli space of flow lines. Moreover, it follows that the evaluation map $e :]f(q), f(p)[\times M(q, p) \rightarrow W(p, q)$ is a homeomorphism since it factors homeomorphically through $\mathbb{R} \times W(p, q)^t$. To summarize we extend 2.1 to the commutative diagram

$$\begin{array}{ccccccc} & &]f(q), f(p)[\times M(q, p) & & \mathcal{M}(p, q) & & \\ & \swarrow \cong & \downarrow \approx & \searrow \cong & \cong \nearrow & \downarrow \pi_* & \\ M(q, p) & & \mathbb{R} \times W(p, q)^t & \xrightarrow{\approx} & W(p, q) & & \mathcal{M}(p, q)/\mathbb{R} & \xrightarrow{\text{embedding}} & \overline{M'(p, q)} \\ \cong \downarrow & \swarrow \cong & \downarrow \pi' & & \downarrow \pi & \cong \nearrow & & & \\ W(p, q)^t & \xleftarrow{\approx} & (\mathbb{R} \times W(p, q)^t)/\mathbb{R} & \xrightarrow{\approx} & M(p, q) & \xrightarrow{\cong} & M'(p, q) & & \end{array} \tag{2.2}$$

where \cong denotes a homeomorphism, \approx a diffeomorphism, and

Space	Name	Reference
$W(p, q)$	The space of connecting orbits.	Section 2.1
$W(p, q)^t$		Section 2.1
$M(p, q)$	The moduli space of orbits.	Section 2.2
$M'(p, q)$		Remark 2.3
$M(q, p)$	The space of height-parameterized flow lines.	Section 2.4
$\mathcal{M}(p, q)$		Remark 2.2

Note then that $M(q, p)$ (and $\mathcal{M}(p, q)$) can be given the structure of a smooth $(\lambda_p - \lambda_q - 1)$ -manifold, however we do not need this. Moreover, by remark 2.3 we see that $(\overline{M'(p, q)}, \gamma \mapsto \mathbb{R} \cdot \gamma(t) \cup \{p, q\})$ is a compactification of $M(q, p)$.

2.11 Claim.

The closure $\overline{M(q, p)}$, in $C([f(q), f(p)], M)$, of the space of height-parameterized flow lines is compact.

Proof:

The claim will be a consequence of the Arzela-Ascoli theorem (see e.g. ([Dug66], Ch.XII.6)). Let $\varepsilon > 0$ and $t \in]f(q), f(p)[$ a regular value. For each $\eta \in M(q, p)$ let $t_\eta \in]f(q), f(p)[$ be such that $t_\eta < t$, $\eta(t_\eta) \in \partial B_\varepsilon(\eta(t))$ and $\eta(]t_\eta, t]) \subset B_\varepsilon(\eta(t))$, where $B_r(c)$ is the open ball of radius r and center c with respect to the Riemannian distance d . Now consider the set $S = \{t_\eta\}_{\eta \in M(q, p)}$, it is clear that $\alpha' = \sup S \leq t$. Assume that $\alpha' = t$. Since t is a regular value, $|\nabla f|$ is bounded below away from zero. Hence for all $\delta > 0$ there exists a t_η such that $d(\eta(t_\eta), \eta(t)) \leq L(\eta, t_\eta, t) \leq \delta$ with L the length functional on $[t_\eta, t]$. In particular we may choose $\delta < \varepsilon$ which is impossible by definition of d , hence $\alpha' < t$. It follows that $\eta(] \alpha', t]) \subset B_\varepsilon(\eta(t))$ for all $\eta \in M(q, p)$ and all $\alpha \in] \alpha', t[$. Now by arguments similar to the above we obtain a $\omega' > t$ such that $\eta([t, \omega[) \subset B_\varepsilon(\eta(t))$ for all $\eta \in M(q, p)$ and all $\omega \in]t, \omega'[$. Since ε was arbitrary we conclude that for all $\varepsilon > 0$ there exists an open neighborhood U_ε of t such that $\eta(U_\varepsilon) \subset B_\varepsilon(\eta(t))$ all $\eta \in M(q, p)$, hence $M(q, p)$ is equicontinuous at t .

If t is a critical value we need the following estimate for $|\nabla f|$ which apply in neighborhoods of the critical points on $f^{-1}(t)$.

We estimate $|\nabla f|$ near a critical point b . Let (ψ, U) be a Morse chart around b . We identify U with $\mathbb{E} = \mathbb{E}^u \oplus \mathbb{E}^s$ having coordinates $z = (x, y)$. By abuse of notation we write f for the local representative $f \circ \psi^{-1}$. Moreover we let $\psi(q) = 0$ and $f(0) = 0$ hence $f(x, y) = -|x|^2 + |y|^2$ by the Morse lemma. Now let $z = z(t)$ denote a height-parameterized flow line, i.e. $f(z) = t$, and $A(z) : T_z U \rightarrow T_z U^*$ the linear isomorphism induced by the Riemannian metric g . We then have

$$|Df(z)| = 2\sqrt{|x|^2 + |y|^2} \geq 2\sqrt{|-|x|^2 + |y|^2|} = 2\sqrt{|t|}$$

and

$$|\nabla f(z)| \geq |A(z)|^{-1} |Df(z)| \geq M^{-1} |Df(z)| \quad \text{with } M = \max_z |A(z)| \geq 0$$

Hence $L(z, t, 0) = L(z, 0, t) \leq M\sqrt{|t|}$, with L the length functional on $[t, 0]$ and $[0, t]$, respectively.

It now follows that $M(q, p)$ is equicontinuous. Since if t is a critical value we may apply the first part of the proof away from the critical points on $f^{-1}(t)$, and use the second part in neighborhoods of the critical points on $f^{-1}(t)$.¹¹

To fulfill the hypothesis of the Arzela-Ascoli theorem we need to show that the closure of $\{\eta(t) \mid \eta \in M(q, p)\}$ is compact for each $t \in [f(q), f(p)]$. But this is clear since M is compact, so $M(q, p)$ is contained in a compact subset, hence the claim follows. \square

Let β be a cluster point of $M(q, p)$ not in $M(q, p)$, hence there exists a sequence $\{\eta_n\} \subset M(q, p)$ such that $\eta_n \rightarrow \beta$. It is clear that β is height-parameterized so let $t_0 = f(q), t_1, \dots, t_k = f(p)$ be the points in $[f(q), f(p)]$ such that $\beta(t_i) \in \text{Crit}(f)$. If necessary rearrange the t_i 's such that $t_i < t_{i+1}$ and let $I_i =]t_{i-1}, t_i[$. Let $X = \nabla f / |\nabla f|^2$, since composition is continuous we see that $\lim \dot{\eta}_n = X(\beta)$ on each I_i , and by theorem 2.12 below it follows that $\dot{\beta} = \lim \dot{\eta}_n$ on each I_i . Hence $\text{im}(\beta)$ is a broken trajectory from q to p of order k as defined in remark 2.3.

We have used the following theorem, a proof of which can be found in ([Apo74], Ch.9.10) (theorem 9.13)

2.12 Theorem.

Assume that each term of $\{f_n\}$ is a real-valued function having a finite derivative at each point of an open interval $I \subseteq \mathbb{R}$. Assume that for at least one point $x_0 \in I$ the sequence $\{f_n(x_0)\}$ converges. Assume further that there exists a function g such that $f'_n \rightarrow g$ uniformly on I . Then:

- a) There exists a function f such that $f_n \rightarrow f$ uniformly on I .
- b) For each $x \in I$ the derivative $f'(x)$ exists and equals $g(x)$.

How is the compactification $(\overline{M'(p, q)}, \eta \mapsto \mathbb{R}.\eta(t) \cup \{p, q\})$ of $M(q, p)$ related to the closure $\overline{M(q, p)}$? Let $M'(p, q) \rightarrow M(q, p)$; $l(m) \mapsto \eta_m$, where $l(m) = \mathbb{R}.m \cup \{p, q\} = \text{im}(\eta_m)$, be the homeomorphism which factors through $W(p, q)^t$ via the homeomorphisms $l(m) \mapsto m \mapsto \eta_m$ (the inverse being $\eta_m \mapsto \mathbb{R}.\eta_m(t) \cup \{p, q\}$). By the above the inverse extends naturally to a continuous map $\overline{M(p, q)} \rightarrow \overline{M'(p, q)}$. This map is surjective since if l is a cluster point of $M'(p, q)$ not

¹¹Note that if $t = f(p)$ (resp. $t = f(q)$) then $] \alpha', t [$ (resp. $[t, \omega' [$) is an open neighborhood of t in $[f(q), f(p)]$.

in $M'(p, q)$ there exists a sequence $\{l(m)_n\} \subset M'(p, q)$ such that $l(m)_n \rightarrow l$. Hence there is a sequence $\{\eta_n\} \subset M(q, p)$ such that $\eta_n \rightarrow \beta$ (possibly for a subsequence) with β a cluster point of $M(q, p)$ not in $M(q, p)$, so $\beta \mapsto l$ proving surjectivity. Moreover, injectivity of this map is also easily proven (the inverse being the extension of $l(m) \mapsto \eta_m$), hence we have proven that:

2.13 Claim.

The homeomorphism $M'(p, q) \rightarrow M(q, p)$ extends to a homeomorphism on the closures (i.e. the completions) $\overline{M'(q, p)} \rightarrow \overline{M(q, p)}$.

In other words the above says that compactification (of $M(q, p) \approx W(p, q)^t \approx M(p, q) \approx M'(p, q)$) w.r.t. Hausdorff topology is homeomorphic to compactification w.r.t c -topology. Moreover, it is important to note that the closure of $W(p, q)^t \subset M$ is not homeomorphic to the compactification above.

2.5 The space of broken flow lines

Let $p, q \in \text{Crit}(f)$ with $\mu(p, q) \geq 0$, $\tilde{M} = M - \text{Crit}(f)$ and $X = \nabla f / |\nabla f|^2$. The last (function) space to be defined is

$$\overline{M}(q, p) = \{\beta \in C([f(q), f(p)], M) \mid \dot{\beta} = X(\beta) \text{ on } \tilde{M}, \beta(f(q)) = q, \beta(f(p)) = p\}$$

which is second countable, perfectly normal and paracompact (see remark 2.7). Elements of this space are curves β starting at q and ending at p with $\text{im}(\beta) = \bigcup_{i=1}^l \text{im}(\eta_{m_i})$ for some $\eta_{m_i} \in M(b_{i-1}, b_i)$ with $b_0 = q$ and $b_l = p$. The space $\overline{M}(q, p)$ is called the space of broken flow lines from q to p , and elements are called either broken flow lines (even though some are non broken), piecewise flow lines, \overline{M} -maps or by abuse of language flow lines. Note that if $\beta \in \overline{M}(q, p)$ then $\beta(f(p)) = p$, if $q \neq p$ and $\mu(p, q) = 0$ then $\overline{M}(q, p) = \emptyset$, and $\overline{M}(q, q)$ has one element the trivial curve $f(q) \mapsto q$.

2.14 Claim.

The space of broken flow lines from q to p is compact.

Proof:

We show that $\overline{M}(q, p) = \overline{M(q, p)}$ which is enough since both spaces carry the subspace topology w.r.t. $C([f(q), f(p)], M)$. Obviously $M(q, p)$ is a subset of both so such elements are of no concern. Now let $\beta \in \overline{M}(q, p)$ so $\text{im}(\beta)$ is a

broken trajectory, hence β is a cluster point of $\overline{M(q, p)}$ (by claim 2.13) and therefore $\beta \in \overline{M(q, p)}$. Conversely, let $\beta \in \overline{M(q, p)}$ then, by the arguments above claim 2.13, β is height-parameterized and $\dot{\beta} = X(\beta)$ on \tilde{M} . \square

It follows from the proof and the above that the space of broken flow lines $\overline{M(q, p)}$ is a compactification of the space of height-parameterized flow lines $M(p, q)$.

2.15 Claim.

The space of height-parameterized flow lines is open in the space of broken flow lines, so $M(q, p) \hookrightarrow \overline{M(q, p)}$ is an open embedding. Moreover, the two spaces are equal if the relative index is one or if $\text{Crit}(f) \cap f^{-1}([f(q), f(p)]) = \emptyset$.

Proof:

Since $\text{im}(\beta) \subset \overline{W(p, q)}$ for any $\beta \in \overline{M(q, p)}$ we see that the topology on $\overline{M(q, p)}$ is the subspace topology coming from $C([f(q), f(p)], \overline{W(p, q)})$. Moreover, $W(p, q)$ is open in $\overline{W(p, q)}$ since any submanifold is locally closed and therefore also open in its closure.¹² Now let $\gamma \in M(q, p)$ and $m = \gamma(t)$, then $m \in W(p, q)$ so let U be an open neighborhood of m in $\overline{W(p, q)}$. The subbasis element $(\{t\}, U) = \{\beta \in \overline{M(q, p)} \mid \beta(\{t\}) \subset U\}$ is then an open neighborhood of γ in $\overline{M(q, p)}$, hence $\beta \in M(q, p)$ for all $\beta \in (\{t\}, U)$ thus proving the first statement.

Now the second statement follows by the formula on page 8 for $\overline{W(p, q)}$, and the last since f is Liapunov. \square

The above proof could be simplified since $M(q, p)$ is the complement of the closed set $\cup_i e_{f(a_i)}^{-1}(a_i)$ where $\{a_i\} = \text{Crit}(f) \cap f^{-1}([f(q), f(p)])$. However we prefer the above method since it describes the topology of $\overline{M(q, p)}$ in a more precise manner. Moreover, by modifying the above proof slightly it is easy to see that $M(q, p)$ is not open in $C([f(q), f(p)], M)$.

We now define a (concatenation) map which in some sense corresponds to the gluing map of theorem 2.16 below with the fixed parameter 0. Let \mathbf{b} be any chain and $\overline{M}(\mathbf{b}) = \prod_{i=1}^{l(\mathbf{b})} \overline{M}(b_{i-1}, b_i)$. If \mathbf{b} has order at most two we define the function $\# : \overline{M}(\mathbf{b}) \rightarrow \overline{M}(\text{sou}(\mathbf{b}), \text{tar}(\mathbf{b}))$ by letting $\# = \mathbf{1}$ if $l(\mathbf{b}) = 1$ or if $\mathbf{b} = \{q, b, p\}$ say, by $(\beta, \beta') \mapsto \#(\beta, \beta') = \beta\#\beta'$ where

$$\beta\#\beta'(t) = \begin{cases} \beta(t) & f(q) \leq t \leq f(b) \\ \beta'(t) & f(b) \leq t \leq f(p) \end{cases} \quad (2.3)$$

¹²See ([Lan99], Ch.II.2) and ([Bou98], Ch.I.3.3)

By adjusting the proof of continuity of the concatenation map ([Dug66],p.377) one sees that $\#$ is continuous¹³, hence for any chain \mathbf{b} there is a continuous map

$$\overline{M}(\mathbf{b}) \rightarrow \overline{M}(\text{sou}(\mathbf{b}), \text{tar}(\mathbf{b})); (\beta_1, \beta_2, \dots, \beta_{l(\mathbf{b})}) \mapsto \beta_1 \# \beta_2 \# \dots \# \beta_{l(\mathbf{b})}$$

which we by abuse of notation also denote $\#$.

By definition of $\overline{M}(q, p)$ we thus have that if $\beta \in \overline{M}(q, p)$ then either it is a height-parameterized flow line $\beta = \eta_m \in M(q, p)$ or there exists a strict chain \mathbf{b} with $q = \text{sou}(\mathbf{b})$ and $p = \text{tar}(\mathbf{b})$, and a sequence $\{m_i\}_{i=1}^{l(\mathbf{b})}$ with $m_i \in \mathbb{W}(b_i, b_{i-1})$ (or equivalently $m_i \in \mathbb{W}(b_i, b_{i-1})^{t_i} \approx \mathbb{M}(b_i, b_{i-1})$) such that $\beta = \#(\eta_{m_1}, \eta_{m_2}, \dots, \eta_{m_{l(\mathbf{b})}})$ for $(\eta_{m_1}, \eta_{m_2}, \dots, \eta_{m_{l(\mathbf{b})}}) \in M(\mathbf{b})$ i.e. β is the concatenation of height-parameterized flow lines. Note that there are infinitely many chains corresponding to $\beta \in \overline{M}(q, p)$, namely one strict chain and infinitely many degenerated chains, that is chains which contains more than one copy of the same element. To avoid this, a chain is henceforth considered to be strict if it occurs in connection with the map $\#$.

The forthcoming chapters are devoted to a more detailed analysis of the space of broken flow lines. More precisely we study the connectivity of $\overline{M}(q, p)$ and the relation between the path components of $\overline{M}(q, p)$ and $M(q, p)$.

2.5.1 Appendix

In this appendix we will comment on a construction of a compact space which in the literature is describe as a compactification of $\mathbb{M}(p, q)$ into a smooth manifold with corners. This compactification consists of two results, the first one being the compactness statement of theorem 2.1 and the second result describes how one can glue orbits from lower dimensional moduli spaces together to form an orbit in a higher dimensional moduli space. Geometrically this corresponds to gluing flow lines together to form another flow line.

2.16 Theorem.

Let \mathbf{b} be a strict inverse chain of order l with $p = \text{sou}(\mathbf{b})$ and $q = \text{tar}(\mathbf{b})$. For sufficiently small $\varepsilon > 0$ there exists an embedding

$$G_{\mathbf{b}} = G : \mathbb{M}(\mathbf{b}) \times \prod_{i=2}^l]0, \varepsilon[\rightarrow \mathbb{M}(p, q); (\overline{m}, \overline{t}) \mapsto G(\overline{m}, \overline{t})$$

¹³See ([Let03],Ch.2.2)

mapping $\text{dom}(G)$ diffeomorphically onto an open set in $M(p, q)$. Moreover, $G(\bar{m}, \bar{t}) \rightarrow \bar{x}$ for $\bar{t} \rightarrow 0$, and if $m_n \in M(p, q)$ converges to a broken orbit of order $l(\mathbf{b})$ then $m_n \in \text{im}(G_{\mathbf{b}})$ for large n .

The map G is called the gluing map and usually written as $G(\bar{m}, \bar{t}) = m_1 \#_{t_2} \cdots \#_{t_l} m_l$. The statement of theorem 2.16 can be found in ([AB95], Ch.2). However, the proof in ([AB95], Ch.A.2) only shows that theorem 2.16 is true in the case of a simple gluing map i.e. $l(\mathbf{b}) = 2$. Furthermore, there is no explanation regarding the construction of a “general” gluing map as above. Presumably a general gluing map is defined recursively by means of simple gluing maps, but this immediately raises the question of associativity $(m_1 \#_{t_2} m_2) \#_{t_3} m_3 \stackrel{?}{=} m_1 \#_{t_2} (m_2 \#_{t_3} m_3)$ which seems to be highly non trivial. In ([Sch93], Ch.2.5) the problem of associativity is mentioned. Moreover in [Coh92] and [CJS95] the question of associativity is addressed but not proven. When $l(\mathbf{b}) = 2$ other versions of the gluing theorem can be found in ([Sch93], Ch.2.5) or ([Web06], Ch.3.3).

We can now depict the statement of ([AB95], Ch.2) that $M(p, q)$ has a compactification $\overline{M(p, q)} = M(p, q) \cup \bigcup_{\mathbf{b}} M(\mathbf{b}) \times \prod_{i=2}^{l(\mathbf{b})} [0, \varepsilon[$ which is a smooth manifold with corners. Here the union is taken over all nontrivial strict inverse chains \mathbf{b} with $p = \text{sou}(\mathbf{b})$ and $q = \text{tar}(\mathbf{b})$. In ([AB95], Ch.2) it is claimed that the compactification follows from theorem 2.1 and 2.16, however there is no description of the manifold structure or even the topological structure of $\overline{M(p, q)}$. In [Coh92] and [CJS95] one can find a discussion regarding the topology of $\overline{M(p, q)}$, where the latter describe the compactification as $\overline{M(p, q)} = M(p, q) \cup \bigcup_{\mathbf{b}} M(\mathbf{b})$. It should be noted that a complete proof of the compactification statement in the realm of Floer theory can be found in ([BC03], App.A).

In the sequel we present two constructions which might give a clue as to what topology $\overline{M(p, q)}$ should have. The first construction is based on the categorical pushout construction (see e.g. ([Bor94], Ch.2.5) or ([ML98], Ch.III.3)), which should be compared to the general method of pasting topological spaces together as found in ([Bou98], Ch.I.2.5). The second construction is a somewhat naive construction. Even though we do not prove it, it seems to be true that these two constructions are topologically equivalent.

Let L be the set of all nontrivial ($l(\mathbf{b}) \geq 2$) strict inverse chains \mathbf{b} with $p = \text{sou}(\mathbf{b})$ and $q = \text{tar}(\mathbf{b})$. For convenience set $M = M(p, q)$, and for each $\mathbf{b} \in L$ define the product space $\overline{X(\mathbf{b})} = M(\mathbf{b}) \times \prod_{i=2}^{l(\mathbf{b})} [0, \varepsilon[$ and the subspaces $X(\mathbf{b}) \subset \overline{X(\mathbf{b})}$ by $X(\mathbf{b}) = M(\mathbf{b}) \times \prod_{i=2}^{l(\mathbf{b})}]0, \varepsilon[$.

By means of general nonsense we now proceed with the first construction. For each $\mathbf{b} \in L$ we have, in the category \mathbf{Top} , a pushout diagram

$$\begin{array}{ccc} X(\mathbf{b}) & \xrightarrow{G} & M \\ \downarrow & & \downarrow \\ \overline{X(\mathbf{b})} & \longrightarrow & P(\mathbf{b}) = M *__{X(\mathbf{b})} \overline{X(\mathbf{b})} \end{array}$$

which, by means of the right vertical maps, induces the pushout graph (with $l = \#L$)

$$\begin{array}{ccccccccccc} a_{10} & \longrightarrow & a_{11} & \longrightarrow & a_{12} & \longrightarrow & a_{13} & \longrightarrow & \cdots & \longrightarrow & a_{1l} & (2.4) \\ \parallel & & \nearrow & & \nearrow & & & & & & \nearrow & \\ a_{20} & \longrightarrow & a_{21} & \longrightarrow & a_{22} & \longrightarrow & & & & & & \\ \parallel & & \nearrow & & & & & & & & & \\ a_{30} & \longrightarrow & a_{31} & \longrightarrow & & & & & & & & \\ \parallel & & & & & & & & & & & \\ \vdots & & & & & & & & & & & \\ \parallel & & \nearrow & & & & & & & & & \\ a_{(l-1)0} & \longrightarrow & a_{(l-1)1} & \longrightarrow & & & & & & & & \\ \parallel & & \nearrow & & & & & & & & & \\ a_{l0} & \longrightarrow & a_{l1} & \longrightarrow & & & & & & & & \end{array}$$

with $a_{i0} = M$, $a_{i1} = P(\mathbf{b}_i)$ and $a_{ij} = a_{i(j-1)} *__{a_{(i+1)(j-2)}} a_{(i+1)(j-1)}$ for $1 \leq i \leq \#L$ and $2 \leq j \leq \#L$.

Note that X is topologically independent of how the elements of L are indexed. Indeed, by consider the pushout diagram

$$\begin{array}{ccccc} a_{i1} & \longrightarrow & a_{i2} & \longrightarrow & a_{i3} \\ \uparrow f & & \uparrow & & \uparrow \\ & & a_{(i+1)1} & & \\ & \nearrow & & \searrow & \\ a_{i0} & \cdots & h & \cdots & a_{(i+1)2} \\ & \searrow & & \nearrow & \\ & & a_{(i+2)1} & & \\ \downarrow f & & \downarrow & & \downarrow \\ a_{i1} & \longrightarrow & P & \longrightarrow & P' \end{array}$$

we see that a_{i3} is the pushout of the pair (f, h) but so is P' , hence $a_{i3} \cong P'$. We conclude that if the maps $M \rightarrow a_{i1}$ and $M \rightarrow a_{(i+1)1}$ in diagram (2.4)

are interchanged we obtain a pushout homeomorphic to X . By recursion this clearly generalizes to any permutation of the index set. It now follows that (with $l = \#L$)

$$\begin{aligned}
X &= a_{1l} \\
&= a_{1(l-1)} *_{a_{2(l-2)}} a_{2(l-1)} \\
&= a_{1(l-2)} *_{a_{2(l-3)}} a_{2(l-2)} *_{a_{2(l-2)}} a_{2(l-2)} *_{a_{3(l-3)}} a_{3(l-2)} \\
&= a_{1(l-2)} *_{a_{2(l-3)}} a_{2(l-2)} *_{a_{3(l-3)}} a_{3(l-2)} = \cdots = a_{11} *_{a_{20}} a_{21} *_{a_{30}} \cdots *_{a_{l0}} a_{l1} \\
&= P(\mathbf{b}_1) *_M P(\mathbf{b}_2) *_M \cdots *_M P(\mathbf{b}_l) \\
&= M *_X(\mathbf{b}_1) \overline{X(\mathbf{b}_1)} *_M M *_X(\mathbf{b}_2) \overline{X(\mathbf{b}_1)} *_M \cdots *_M M *_X(\mathbf{b}_l) \overline{X(\mathbf{b}_l)} \\
&= M *_X(\mathbf{b}_1) \overline{X(\mathbf{b}_1)} *_X(\mathbf{b}_2) \overline{X(\mathbf{b}_1)} *_X(\mathbf{b}_2) \cdots *_X(\mathbf{b}_l) \overline{X(\mathbf{b}_l)}
\end{aligned}$$

That is X is formed by pasting the $\overline{X(\mathbf{b})}$'s to M along the $X(\mathbf{b})$'s. The equalities above follow by either definition or associativity of the pushout. That is, if \mathbf{C} is a category with pushouts then $(A *_B C) *_D E = A *_B (C *_D E)$ since the pushout diagram

$$\begin{array}{ccccc}
& & D & \longrightarrow & E \\
& & \downarrow & & \downarrow \\
B & \longrightarrow & C & \longrightarrow & P_2 \\
\downarrow & & \downarrow & & \downarrow \\
A & \longrightarrow & P_1 & \longrightarrow & P
\end{array}$$

shows that $P_1 *_D E = P_1 *_C P_2 = A *_B P_2$.

The (quotient) space X is not quite the topological model of $\overline{M(p, q)}$ we are looking for, as the next example will show. Let $\mathbf{b} = \{p, b_1, b_2, q\}$, $\mathbf{b}' = \{p, b_2, q\}$ and consider $G : X(\mathbf{b}) \rightarrow M; (m_1, m_2, m_3; t_2, t_3) \mapsto m_1 \#_{t_2} m_2 \#_{t_3} m_3$. The subspace $M(p, b_1) \times M(b_1, b_2) \times M(b_2, q) \times]0, \varepsilon[\times \{0\}$ of $\overline{X(\mathbf{b})}$ is not identified with $M(p, b_2) \times M(b_2, q) \times \{0\} \subset \overline{X(\mathbf{b}'})$ via the above construction. As a consequence we have that $(m_1, m_2, m_3; t_2, 0) \neq m_1 \#_{t_2} m_2 \#_0 m_3 = (m_1 \#_{t_2} m_2, m_3)$ and these two points of X can not be separated by open sets, hence $X \notin \mathbf{Haus}$ i.e. X is not an object of the category \mathbf{Haus} . To solve this problem we use the functor $H : \mathbf{Top} \rightarrow \mathbf{Haus}$ which is left adjoint to the inclusion functor, see ([ML98], Ch.V.9). This is in fact how one creates pushouts in \mathbf{Haus} . Moreover, the functor H (obtained by the adjoint functor theorem) or more precise HX can be described as “the largest Hausdorff quotient” of X .

It seems reasonable to conjecture that the inclusion $\iota : M \hookrightarrow HX$ is an embedding, that HX is a compact Hausdorff space (as a consequence of theorem 2.1)

and that $\iota(M) \subset HX$ is dense (by the description of a neighborhood in HX of a broken orbit, via the gluing maps). Hence (HX, ι) is a compactification of $M = M(p, q)$. Since the above construction is fairly obvious when given the gluing data we speculate that the underlying topology on $\overline{M(p, q)}$ could in fact be that of HX .

Before proceeding to the second construction note that as a set HX can be write as $HX = M(p, q) \cup \bigcup_{\mathbf{b} \in L} M(\mathbf{b})$ where we use the identification $M(\mathbf{b}) \approx M(\mathbf{b}) \times \{0\}_{i=2}^{l(\mathbf{b})}$, and $\bigcup_{\mathbf{b} \in L^k} M(\mathbf{b})$ where $L^k = \{\mathbf{b} \in L \mid l(\mathbf{b}) = k\}$ is a “codimensional $k - 1$ strata” for HX .

Now the second construction is simply to consider $Y \in \mathbf{Set}$ the object in the category \mathbf{Set} defined by $Y = \overline{M(p, q)} \cup \bigcup_{\mathbf{b} \in L} M(\mathbf{b})$, and give Y the final topology with respect to the family $\{G_{\mathbf{b}} : \overline{X(\mathbf{b})} \rightarrow Y\}_{\mathbf{b} \in L}$ of “extended” gluing maps. Each $G_{\mathbf{b}}$ then becomes an embedding, and again it seems reasonable to conjecture that Y is a compactification of $M(p, q)$.

It is important to note that both constructions above relies crucially on theorem 2.16 i.e. the existence of gluing maps with more than one parameter. Moreover, the discussion above should be compared to the last paragraph of remark 2.3.

Chapter 3

Connectivity and the space of broken flow lines

In this chapter we investigate the connectivity of the space of broken flow lines by means of its (co)homology. To do so we introduce equivalence relations on the space of broken flow lines which enable us to make a local analysis of this space. Together with a pullback construction (derived from the equivalence relations) this local analysis yields an “inductive” procedure to analyse the (co)homology of the space of broken flow lines.

As in chapter 2 we fix a Morse function $f : M \rightarrow \mathbb{R}$ on a closed n -manifold M and a Riemannian metric g on M such that the pair (f, g) is Morse-Smale.

In section 3.1 we setup some assumptions and notation which applies to the rest of this chapter. In section 3.2 we define equivalence relations on the space of broken flow lines and investigate the resulting quotient spaces. In section 3.3 we construct pullbacks of the quotient spaces defined in section 3.2. Moreover, by means of the Vietoris-Begle mapping theorem we show that, in certain dimensions, these pullbacks induce isomorphisms in Čech cohomology. In particular, when there is exactly one critical point of index 0 and one critical point of index n these isomorphisms can be used to show that the space of broken flow lines is connected if there are no critical points of index 1 or $n - 1$.

3.1 Assumptions

In the rest of this chapter the following will be assumed. Let $\text{Crit}(f) = \{a_i\}$ where $i = 0, 1, \dots, w = \#\text{Crit}(f) - 1$. We choose the indexing such that $\lambda_{a_0} = 0$, $\lambda_{a_w} = n$ and assume that $\#\text{Crit}_i(f) = 1$ for $i = 0, n$, where we usually prefer to write q (resp. p) for a_0 (resp. a_w). Moreover, we assume that $f(a_i) \neq f(a_j)$ for all $i \neq j$, and let $\tau_i \in \mathbb{R}$ denote a scalar such that $f(a_i) < \tau_i < f(a_{i+1})$. In summary we have

$$f(q = a_0) < \tau_0 < f(a_1) < \tau_1 < f(a_2) < \tau_2 < \dots < f(a_{w-1}) < \tau_{w-1} < f(p = a_w) \quad (3.1)$$

When we write $W(a_i, a_j)^t$ it will be understood that t is chosen appropriately, i.e. $t = \tau_l$ a regular value with $i \leq l \leq j$. The same applies for $W^u(a_i)^t$ and $W^s(a_i)^t$ with the obvious changes.

We comment on the above assumptions. First, by ([Mat02], Ch.3.3) one can perturb any Morse function such that the assumption $f(a_i) \neq f(a_j)$ for all $i \neq j$ holds. Moreover, as we shall see at the end of this chapter this assumption is in fact redundant and only included for simplicity. Secondly, the assumption $\#\text{Crit}_i(f) = 1$ for $i = 0, n$ can also be obtained for any Morse function by a perturbation (see the proof of theorem 3.35 in [Mat02]).

3.1 Remark: When restricting to $\overline{W(p, q)}$, most of the results in this chapter generalizes to the case of $\#\text{Crit}_i(f) > 1$ for $i = 0, n$. This fact will not be used, hence we leave this generalization to the reader. ■

3.2 Quotients of the space of broken flow lines

We begin this section by constructing various quotient spaces of $\overline{M}(q, p)$. For $i \leq j$ we define the (equivalence) relation $\sim_{\tau_i, \tau_j} \subset \overline{M}(q, p) \times \overline{M}(q, p)$ by $\beta \sim_{\tau_i, \tau_j} \beta'$ iff $\beta(t) = \beta'(t)$ for all $t \in [\tau_i, \tau_j]$. Since $f(a_i) < \tau_i < f(a_{i+1})$ and $f(a_j) < \tau_j < f(a_{j+1})$, it is trivial to check that;

3.2 Claim.

For any pair (τ'_i, τ'_j) with $\tau'_i \in]f(a_i), f(a_{i+1})[$ and $\tau'_j \in]f(a_j), f(a_{j+1})[$ we have $\sim_{\tau_i, \tau_j} = \sim_{\tau'_i, \tau'_j}$.

Furthermore, it follows that

$$\sim_{\tau_i, \tau_j} \cap \sim_{\tau_k, \tau_l} = \begin{cases} \sim_{\tau_i, \tau_l} & \text{if } i \leq k \leq j \leq l \\ \sim_{\tau_i, \tau_j} & \text{if } i \leq k \leq l \leq j \end{cases} \quad (3.2)$$

and in particular $\sim_{\tau_i, \tau_j} \subset \sim_{\tau_k, \tau_l}$ if $i \leq k \leq l \leq j$. Hence from (3.2) we immediately obtain that;

3.3 Claim.

For $i_1 \leq i_2 \leq i_3 \leq i_4$ the diagram (3.3) is a pullback diagram in \mathbf{Set} , the category of sets.

$$\begin{array}{ccc} \sim_{\tau_{i_1}, \tau_{i_4}} & \hookrightarrow & \sim_{\tau_{i_2}, \tau_{i_4}} \\ \downarrow & & \downarrow \\ \sim_{\tau_{i_1}, \tau_{i_3}} & \hookrightarrow & \sim_{\tau_{i_2}, \tau_{i_3}} \end{array} \quad (3.3)$$

With the relation above we define the quotient space $\overline{M}(\tau_i, \tau_j) = \overline{M}(q, p) / \sim_{\tau_i, \tau_j}$, and note that $\overline{M}(\tau_i, \tau_j) = \overline{M}(\tau'_i, \tau'_j)$ for any pair (τ'_i, τ'_j) as in claim 3.2. By claim 2.14 it follows that this quotient space is compact, and as we shall see below (claim 3.5) this space is in fact compact Hausdorff.

3.4 Claim.

The inclusion $M(q, p) \hookrightarrow \overline{M}(q, p)$ induces an embedding $M(q, p) / \sim_{\tau_i, \tau_j} \hookrightarrow \overline{M}(\tau_i, \tau_j)$.

Proof:

If $\beta, \beta' \in M(q, p)$, then $\beta(t) = \beta'(t)$ for all $t \in [\tau_i, \tau_j]$ iff $\beta(t) = \beta'(t)$ for some $t \in [\tau_i, \tau_j]$. Thus, $M(q, p) / \sim_{\tau_i, \tau_j} \approx M(q, p)$. The claim now follows by considering the diagram

$$\begin{array}{ccc} M(q, p) & \xhookrightarrow{\iota} & \overline{M}(q, p) \\ \pi = \mathbf{1} \downarrow & & \downarrow \pi' \\ M(q, p) & \xhookrightarrow{\iota'} & \overline{M}(\tau_i, \tau_j) \end{array}$$

where ι' is the unique continuous map such that $\pi' \circ \iota = \iota' \circ \pi$ (since $\pi' \circ \iota$ is constant on the fibers of π i.e. $\pi' \circ \iota$ respects the equivalence relation \sim_{τ_i, τ_j} , ([Lee00], Ch.3.3)). \square

It follows from the above that ι' is in fact an open embedding. Indeed, let $O \subset M(q, p)$ be open, then $\iota'(O) = \pi' \circ \iota(O)$ is open iff $\pi'^{-1}(\pi' \circ \iota(O))$ is open. But by the above diagram, $\pi'^{-1}(\pi' \circ \iota(O)) = \iota(O)$, which is open by claim 2.15.

3.5 Claim.

The map $\overline{M}(\tau_i, \tau_j) \rightarrow C([\tau_i, \tau_j], \mathbf{M})$; $[\beta] \mapsto \beta|_{[\tau_i, \tau_j]}$ is a homeomorphism onto its image i.e. an embedding. Hence $\overline{M}(\tau_i, \tau_j)$ is a compact Hausdorff space.¹

Proof:

The composition $\overline{M}(q, p) \hookrightarrow C([f(q), f(p)], \mathbf{M}) \xrightarrow{\text{res}} C([\tau_i, \tau_j], \mathbf{M})$, where res denotes the restriction map, factors through $\overline{M}(\tau_i, \tau_j)$ as

$$\begin{array}{ccc} \overline{M}(q, p) & \xrightarrow{\beta \mapsto \beta|_{[\tau_i, \tau_j]}} & C([\tau_i, \tau_j], \mathbf{M}) \\ & \searrow \pi & \nearrow [\beta] \mapsto \beta|_{[\tau_i, \tau_j]} \\ & \overline{M}(\tau_i, \tau_j) & \end{array}$$

Now $\beta \mapsto \beta|_{[\tau_i, \tau_j]}$ is continuous since res is continuous ([Bre93], Ch.VII.2). Hence by the defining property of the quotient/identification map π , ([Bre93], Ch.I.13) we see that that $[\beta] \mapsto \beta|_{[\tau_i, \tau_j]}$ is continuous. Moreover, $[\beta] \mapsto \beta|_{[\tau_i, \tau_j]}$ is injective because \sim_{τ_i, τ_j} identifies maps that agree on $[\tau_i, \tau_j]$, i.e. differences outside of $[\tau_i, \tau_j]$ are ignored in $\overline{M}(\tau_i, \tau_j)$. This proves the claim since $\overline{M}(\tau_i, \tau_j)$ is compact and $C([\tau_i, \tau_j], \mathbf{M})$ is Hausdorff, ([Lee00], Ch.4.2). \square

Thus the above claim gives us a model for the topology on $\overline{M}(\tau_i, \tau_j)$, which is more comprehensible than the original one. Moreover, the identification $[\beta] \leftrightarrow \beta|_{[\tau_i, \tau_j]}$ will be used throughout the rest of this chapter.

3.6 Remark: Let $[\beta] \in \overline{M}(\tau_i, \tau_j)$ and write a representative $\beta \in [\beta]$ as $\beta = \eta_{m_1} \# \cdots \# \eta_{m_l(b)}$. It follows that; 1) if $l(\mathbf{b}) = l = 1$, the only representative of the class $[\beta]$ is the non broken flow line $\beta = \eta_m$. 2) if $l > 1$ then, with say $\tau_i \in [f(b_{v-1}), f(b_v)]$ and $\tau_j \in [f(b_{u-1}), f(b_u)]$ for $1 \leq v < u \leq l - 1$, the class $[\beta]$ is uniquely determined by $\eta_{m_v} \# \cdots \# \eta_{m_u}$.

As a consequence of the above we sometimes write $[\beta] = [\bullet \eta_{m_v} \# \cdots \# \eta_{m_u} \bullet]$. Note that 1) and 2) above reflects the statements of claim 3.4 and 3.5, respectively.

¹The last part can also be proven directly. The compactness is trivial, and the Hausdorff property follows since we may separate $\beta([\tau_i, \tau_j])$ and $\beta'([\tau_i, \tau_j])$ in \mathbf{M} if $\beta \neq \beta'$ in $\overline{M}(\tau_i, \tau_j)$.

Moreover, note that if $\beta \sim_{\tau_i, \tau_j} \beta'$, with \mathbf{b} (resp. \mathbf{b}') the chain connected to β (resp. β'), then $\mathbf{b} \cap \mathbf{b}' \neq \emptyset$ and we may write $\beta = \beta_1 \# \alpha \# \beta_2$ and $\beta' = \beta'_1 \# \alpha \# \beta'_2$, where the chain connected to α is $\mathbf{b} \cap \mathbf{b}'$. ■

Now consider the (non-injective) evaluation map (at τ_i) $\overline{M}(q, p) \xrightarrow{e_{\tau_i}} f^{-1}(\tau_i)$. This is clearly continuous, and it respects the relation \sim_{τ_k, τ_j} (for $k \leq i \leq j$). Hence there is an induced (continuous) map on the quotients. In light of claim 3.5 we also denote the induced map by e_{τ_i} and call it the evaluation map (at τ_i).

3.7 Claim.

The evaluation map (at τ_i) $\overline{M}(\tau_i, \tau_i) \xrightarrow{e_{\tau_i}} f^{-1}(\tau_i)$ is a homeomorphism.

Proof:

We see that e_{τ_i} is a continuous bijection between a compact space and a Hausdorff space. □

3.3 Pullbacks and induced isomorphisms

We start by defining maps between the various quotient spaces of section 3.2. If $i \leq k \leq l \leq j$ let $\Pi : \overline{M}(\tau_i, \tau_j) \rightarrow \overline{M}(\tau_k, \tau_l)$ be the map defined by $\beta[[\tau_i, \tau_j]] \mapsto \beta[[\tau_k, \tau_l]]$. As a passing remark we note that Π would not be well defined if $j < k$.

3.8 Claim.

The map Π is a closed continuous surjection. Moreover, for $\tau_{i_j} \leq \tau_{i_{j+1}}$ the following diagram commutes

$$\begin{array}{ccc} \overline{M}(\tau_{i_0}, \tau_{i_7}) & \longrightarrow & \overline{M}(\tau_{i_2}, \tau_{i_6}) \\ \downarrow & & \downarrow \\ \overline{M}(\tau_{i_1}, \tau_{i_5}) & \longrightarrow & \overline{M}(\tau_{i_3}, \tau_{i_4}) \end{array} \quad (3.4)$$

where all the maps are defined as Π above.

Proof:

It is clear that both the diagram (3.4) commutes and Π is a continuous surjection. Moreover, Π is closed since it is a map between compact spaces.

□

Hence, this says that Π is a closed identification map. Now as hinted by claim 3.3 we may turn diagram (3.4) into a pullback diagram by making some restrictions on the τ_{i_j} 's.

3.9 Claim.

For $\tau_{i_j} \leq \tau_{i_{j+1}}$, diagram (3.5) represents a pullback diagram in $\mathbf{CompHaus}$, the category of compact Hausdorff spaces.

$$\begin{array}{ccc} \overline{M}(\tau_{i_1}, \tau_{i_4}) & \longrightarrow & \overline{M}(\tau_{i_2}, \tau_{i_4}) \\ \downarrow & & \downarrow \\ \overline{M}(\tau_{i_1}, \tau_{i_3}) & \longrightarrow & \overline{M}(\tau_{i_2}, \tau_{i_3}) \end{array} \quad (3.5)$$

Proof:

Diagram (3.5) commutes by claim 3.8. Now let

$$P = \overline{M}(\tau_{i_1}, \tau_{i_3}) \times_{\overline{M}(\tau_{i_2}, \tau_{i_3})} \overline{M}(\tau_{i_2}, \tau_{i_4})$$

denote the pullback of $\overline{M}(\tau_{i_1}, \tau_{i_3}) \longrightarrow \overline{M}(\tau_{i_2}, \tau_{i_3}) \longleftarrow \overline{M}(\tau_{i_2}, \tau_{i_4})$. It is easy to see that the map $\overline{M}(\tau_{i_1}, \tau_{i_4}) \rightarrow P; \beta|[\tau_{i_1}, \tau_{i_4}] \rightarrow (\beta|[\tau_{i_1}, \tau_{i_3}], \beta|[\tau_{i_2}, \tau_{i_4}])$ is a continuous bijection. Hence the claim follows. \square

Now consider the following special case of diagram (3.5)

$$\begin{array}{ccc} \overline{M}(\tau_{i-2}, \tau_i) & \xrightarrow{\overline{\Pi}} & \overline{M}(\tau_{i-1}, \tau_i) \\ \downarrow \overline{\Pi} & & \downarrow \Pi \\ \overline{M}(\tau_{i-2}, \tau_{i-1}) & \xrightarrow{\Pi'} & \overline{M}(\tau_{i-1}, \tau_{i-1}) \end{array} \quad (3.6)$$

We wish to apply the Vietoris-Begle mapping theorem to the map Π (and Π') in diagram 3.6.

3.10 Theorem. (Vietoris-Begle mapping theorem)

Let $P : Y \rightarrow X$ be a closed continuous surjection between paracompact Hausdorff spaces and G a module. Assume that there is an $l \geq 0$ such that the reduced Čech cohomology group $\check{H}^k(P^{-1}(x); G) = 0$ for all $x \in X$ and for $k < l$. Then $P^* : \check{H}^k(X; G) \rightarrow \check{H}^k(Y; G)$ is an isomorphism for $k < l$ and a monomorphism for $k = l$. ([Spa81], p.344(334))

In [Spa81] the above theorem is stated for Alexander cohomology \bar{H}^* , but since X (and Y) are paracompact Hausdorff spaces we have $\bar{H}^*(X) = \check{H}^*(X)$ by corollary 8 in ([Spa81],p.334). By abuse of notation we let $H^* = \check{H}^*$ in the sequel.

3.11 Claim.

The fibers of Π in diagram (3.6) are

$$\Pi^{-1}(m) = \begin{cases} \text{a point} & \text{if } m \in f^{-1}(\tau_{i-1}) - W^u(a_i)^{\tau_{i-1}} \\ \mathbb{S}^{n-\lambda_{a_i}-1} & \text{if } m \in W^u(a_i)^{\tau_{i-1}} \end{cases}$$

where we have used the identification $\bar{M}(\tau_{i-1}, \tau_{i-1}) \approx f^{-1}(\tau_{i-1})$ of claim 3.7.

Proof:

With the above identification Π is simply the evaluation map at τ_{i-1} . Let $m \in f^{-1}(\tau_{i-1}) - W^u(a_i)^{\tau_{i-1}}$ and assume that $\beta|[\tau_{i-1}, \tau_i], \beta'|[\tau_{i-1}, \tau_i] \in \Pi^{-1}(m)$, i.e. $\beta(\tau_{i-1}) = \beta'(\tau_{i-1})$. But then $\beta|[\tau_{i-1}, \tau_i] = \beta'|[\tau_{i-1}, \tau_i]$ since $a_i \notin \mathbf{b} \cap \mathbf{b}'$, where \mathbf{b} (resp. \mathbf{b}') represent the chain connected to β (resp. β').

If $m \in W^u(a_i)^{\tau_{i-1}}$ then $\Pi^{-1}(m) = \{\beta|[\tau_{i-1}, \tau_i] \in \bar{M}(\tau_{i-1}, \tau_i) \mid a_i \in \text{im}(\beta) \text{ and } \beta(\tau_{i-1}) = m\}$ which is compact. Now the map $\Pi^{-1}(m) \rightarrow \{m\} \times W^s(a_i)^{\tau_i}$; $\beta|[\tau_{i-1}, \tau_i] \mapsto (\beta(\tau_{i-1}), \beta(\tau_i))$ is easily seen to be a continuous bijection, and hence a homeomorphism. This proves the claim since $\{m\} \times W^s(a_i)^{\tau_i} \approx \mathbb{S}^{n-\lambda_{a_i}-1}$. \square

The Vietoris-Begle mapping theorem now yields that $\Pi^* : H^k(\bar{M}(\tau_{i-1}, \tau_{i-1})) \rightarrow H^k(\bar{M}(\tau_{i-1}, \tau_i))$ is an isomorphism for $k < n - \lambda_{a_i} - 1$ and a monomorphism for $k = n - \lambda_{a_i} - 1$. Now by the pullback property of diagram (3.6) we will see, in the following remark on abstract nonsense, that the fibers of Π and $\bar{\Pi}$ are in fact identical.

3.12 Remark: Let \mathbf{C} be a category with pullbacks. The fiber of a morphism $f : A \rightarrow C$ over a morphism $g : E \rightarrow C$ is by definition the pullback $E \times_C A$. Note that if $\mathbf{C} = \mathbf{Set}$, g is the inclusion, and E a subset of C , the above definition agrees with the set theoretic notion of $f^{-1}(E)$, the inverse image of E under f .

Now given the pullback diagram

$$\begin{array}{ccc} A & \xrightarrow{h'} & B \\ \downarrow f & & \downarrow f' \\ C & \xrightarrow{h} & D \end{array}$$

We claim that the fiber over $g : E \rightarrow C$ of f is the fiber over $E \xrightarrow{g} C \xrightarrow{h} D$ of f' . This follows by considering the pullback diagram

$$\begin{array}{ccccc} E \times_C A & \longrightarrow & A & \xrightarrow{h'} & B \\ \downarrow & & \downarrow f & & \downarrow f' \\ E & \xrightarrow{g} & C & \xrightarrow{h} & D \end{array}$$

and noting that $E \times_D B \approx E \times_C A$ since both squares are pullback diagrams ([Bor94], Ch.2.5). \blacksquare

It now follows that $\bar{\Pi}^{-1}([\beta]) = \Pi^{-1}(\Pi'([\beta]))$. Hence the fiber of $\bar{\Pi}$ is either a point or the sphere $\mathbb{S}^{n-\lambda_{a_i}-1}$, so $\bar{\Pi}^* : \mathbb{H}^k(\bar{M}(\tau_{i-2}, \tau_{i-1})) \rightarrow \mathbb{H}^k(\bar{M}(\tau_{i-2}, \tau_i))$ is an isomorphism for $k < n - \lambda_{a_i} - 1$ and a monomorphism for $k = n - \lambda_{a_i} - 1$. Similar arguments shows that the pair of maps $(\Pi', \bar{\Pi}')$ also induce isomorphisms in Čech cohomology for $k < \lambda_{a_{i-1}} - 1$ and monomorphisms for $k = \lambda_{a_{i-1}} - 1$. In summary, we have the following commutative diagram

$$\begin{array}{ccc} \mathbb{H}^k(\bar{M}(\tau_{i-2}, \tau_i)) & \xleftarrow{\bar{\Pi}'^*} & \mathbb{H}^k(\bar{M}(\tau_{i-1}, \tau_i)) \\ \uparrow \bar{\Pi}^* & & \uparrow \Pi'^* \\ \mathbb{H}^k(\bar{M}(\tau_{i-2}, \tau_{i-1})) & \xleftarrow{\Pi'^*} & \mathbb{H}^k(\bar{M}(\tau_{i-1}, \tau_{i-1})) \end{array} \quad (3.7)$$

where the vertical maps are isomorphisms for $k < n - \lambda_{a_i} - 1$ and monomorphisms for $k = n - \lambda_{a_i} - 1$, and the horizontal maps are isomorphisms for $k < \lambda_{a_{i-1}} - 1$ and monomorphisms for $k = \lambda_{a_{i-1}} - 1$.

We proceed by showing how $\bar{M}(q, p)$ (or rather $\mathbb{H}^k(\bar{M}(q, p))$) fits into the above construction. First consider the following commutative diagram induced by the diagram on spaces

$$\begin{array}{ccccc} \mathbb{H}^k(\bar{M}(\tau_{i-2}, \tau_{i+1})) & \longleftarrow & \mathbb{H}^k(\bar{M}(\tau_{i-1}, \tau_{i+1})) & \longleftarrow & \mathbb{H}^k(\bar{M}(\tau_i, \tau_{i+1})) \\ \uparrow & & \uparrow & & \uparrow \\ \mathbb{H}^k(\bar{M}(\tau_{i-2}, \tau_i)) & \longleftarrow & \mathbb{H}^k(\bar{M}(\tau_{i-1}, \tau_i)) & \longleftarrow & \mathbb{H}^k(\bar{M}(\tau_i, \tau_i)) \\ \uparrow & & \uparrow & & \\ \mathbb{H}^k(\bar{M}(\tau_{i-2}, \tau_{i-1})) & \longleftarrow & \mathbb{H}^k(\bar{M}(\tau_{i-1}, \tau_{i-1})) & & \end{array} \quad (3.8)$$

The lower square and the right square in the above diagram are of the same type as diagram 3.7. Moreover, the (upper) left square comes from a pullback diagram (claim 3.9), so as above we conclude that the horizontal (resp.

Using the identification $\overline{M}(\tau_i, \tau_i) \approx f^{-1}(\tau_i)$ of claim 3.7 we immediately obtain the following lemma.

3.13 Lemma.

Let $J = \{1, 2, \dots, w-1\}$ and $J' = \{i+1, i+2, \dots, i+l\}$, then

- 1) $\mathbb{H}^k(\overline{M}(q, p)) \approx \mathbb{H}^k(f^{-1}(\tau_{w-1}))$ if $0 \leq k \leq m-2$, where $m = \min_{j \in J} \{\lambda_{a_j}\}$.
- 2) $\mathbb{H}^k(\overline{M}(q, p)) \approx \mathbb{H}^k(f^{-1}(\tau_0))$ if $0 \leq k \leq n-2-M$, where $M = \max_{j \in J} \{\lambda_{a_j}\}$.
- 3) $\mathbb{H}^k(f^{-1}(\tau_i)) \approx \mathbb{H}^k(f^{-1}(\tau_{i+l}))$ if $0 \leq k \leq \min_{j \in J'} \{\lambda_{a_j} - 2, n-2 - \lambda_{a_j}\}$.

In particular $\mathbb{H}^0(\overline{M}(q, p)) \approx \mathbb{H}^0(f^{-1}(\tau_j))$ for all $j \in J$ if $\lambda_{a_j} \neq 1, n-1$ for all $j \in J$.

3.14 Remark: Note that the lemma is an empty statement if $n = \dim(M) \leq 2$, that (1) is an empty statement if $m = 1$, that (2) is an empty statement if $M = n-1$, and that (3) is an empty statement if $\lambda_{a_j} = 1, n-1$. ■

We can now say a bit about the connectivity of $\overline{M}(q, p)$. More precisely we obtain a necessary condition for $\overline{M}(q, p)$ to be connected.

3.15 Corollary.

The space of broken flow lines is connected if there exists no critical point of index 1 (or $n-1$). Moreover, the number of path components of a level surface remains constant when passing a critical level surface if the index of the corresponding critical point is different from 1 and $n-1$.

Proof:

The rank of $\mathbb{H}^0(\overline{M}(q, p))$ can be interpreted as the number of components of $\overline{M}(q, p)$ (see ([Spa81], Ch.6.4)). Hence we obtain the first assertion by lemma 3.13(1), since $f^{-1}(\tau_{w-1}) \approx \mathbb{S}^{n-1}$. Moreover, since $f^{-1}(\tau_i)$ is an ENR (Euclidean Neighborhood Retract, see ([Dol80], Ch.IV.8)) for any i , the Čech cohomology coincides with ordinary singular cohomology (see e.g. proposition 6.12 in ([Dol80], Ch.IV.8)). Hence we may interpret the rank of $\mathbb{H}^0(f^{-1}(\tau_i))$ as the number of path components of $f^{-1}(\tau_i)$ (see ([Spa81], Ch.5.4)). By lemma 3.13(3), this proves the last part of the corollary □

To this end we indicate that the assumption $f(a_i) \neq f(a_j)$ from section 3.1 is redundant. Assume that on the level surface corresponding to a_i there are k

critical points a_{i1}, \dots, a_{ik} . In this case only claim 3.11 needs to be changed, all other results holds without any changes to statements and proofs. The correct conclusion of claim 3.11 in this case is

$$\Pi^{-1}(m) = \begin{cases} \text{a point} & \text{if } m \in f^{-1}(\tau_{i-1}) - \bigcup_j W^u(a_{ij})^{\tau_{i-1}} \\ \mathbb{S}^{n-\lambda_{a_{ij}}-1} & \text{if } m \in W^u(a_{ij})^{\tau_{i-1}} \end{cases}$$

and the proof holds readily. We summarize in the following theorem.

3.16 Theorem.

Let $f : M \rightarrow \mathbb{R}$ be a Morse-Smale function with only one minimum q and one maximum p , and let τ_i, τ_j be regular values such that $f(q) < \tau_i \leq \tau_j < f(p)$. With $m = \min_{a \neq q} \{\lambda_a \mid f(a) < \tau_i\}$ and $M = \max_{a \neq p} \{\lambda_a \mid f(a) > \tau_j\}$, the restriction map $\overline{M}(q, p) \rightarrow \overline{M}(\tau_i, \tau_j); \beta \mapsto \beta|_{[\tau_i, \tau_j]}$ induces an isomorphism in Čech cohomology in degree $< \min\{m-1, n-1-M\}$ and a monomorphism in degree $\min\{m-1, n-1-M\}$. In particular $\overline{M}(q, p)$ is connected if there are no critical points of index 1 (or $n-1$).

In ([Mat02],p.90) a Morse function $f : \mathbb{C}\mathbb{P}^n \rightarrow \mathbb{R}$ is constructed, with $n+1$ critical points of index $0, 2, \dots, 2n$. Hence $\overline{\mathbb{C}\mathbb{P}^n}(q, p)$ is connected with respect to this Morse function.

3.4 Appendix

Recall that for $k=0$ all the maps in diagram 3.9 are isomorphisms onto there images. Hence $\max_{\tau} \{\text{Rank}(\mathbb{H}_0(f^{-1}(\tau)))\} \leq \text{Rank}(\mathbb{H}^0(\overline{M}(q, p)))$, and by corollary 3.15 this lower bound only depends on the critical points of index 1 and $n-1$. In this appendix we will elaborate a bit more on how the path components of level surfaces changes when passing a critical point of index 1 or $n-1$. The following is implicit in the literature on handle body's. Moreover, we make no assumptions on the critical points of the Morse function.

Assume that $\lambda_{a_i} = 1$, $\lambda_{a_j} = n-1$ and for $k=i, j$ let $W_k = f^{-1}([\tau_{k-1}, \tau_k])$, $V_k = M^{\tau_{k-1}}$ and $V'_k = M^{\tau_k}$. The triple (W_k, V_k, V'_k) is then an elementary cobordism in the sense of ([Mil65],p.28) since f is a Morse function on the manifold triad (W_k, V_k, V'_k) with exactly one critical point (see ([Mil65],p.2,8)). By lemma 3.2 in [Mil65] there exists a gradient like vector field for f , so we may apply corollary 3.15 (of theorem 3.14) in [Mil65] to conclude that $\mathbb{H}_*(W_k, V_k)$ is \mathbb{Z} (generated by $[W^u(a_k)]$) in dimension λ_{a_k} and zero otherwise. Moreover,

with minor modifications (replace D_L by D_R) the proof of theorem 3.14 also yields a dual corollary; $H_*(W_k, V'_k)$ is \mathbb{Z} (generated by $[W^s(a_k)]$) in dimension $n - \lambda_{a_k}$ and zero otherwise. Now assume that $n = \dim(M) > 2$, then we obtain the following two exact sequences based on the long exact sequence of the pairs (W_k, V_k) and (W_k, V'_k)

$$\begin{aligned} 0 &\longrightarrow H_1(V_i) \longrightarrow H_1(W_i) \xrightarrow{\alpha_i} \mathbb{Z} \longrightarrow H_0(V_i) \longrightarrow H_0(V'_i) \longrightarrow 0 \\ 0 &\longrightarrow H_1(V'_j) \longrightarrow H_1(W_j) \xrightarrow{\alpha_j} \mathbb{Z} \longrightarrow H_0(V'_j) \longrightarrow H_0(V_j) \longrightarrow 0 \end{aligned}$$

where the isomorphisms $H_0(W_i) \approx H_0(V'_i)$ and $H_0(W_j) \approx H_0(V_j)$ are due to the assumption $n > 2$. Since $H_0(\cdot)$ is free we see that α_k is either 0 or surjective, hence

$$\beta_0(V'_k) = \begin{cases} \beta_0(V_k) & \text{if } \alpha_k \text{ surjective} \\ \beta_0(V_k) \pm 1 & \text{if } \alpha_k = 0 \text{ with } - \text{ if } k = i \text{ and with } + \text{ if } k = j \end{cases}$$

where $\beta_l(X) = \text{Rank}(H_l(X))$ the l 'th Betti number of X . It then follows that the number of path components of a level surfaces either remains constant or reduces (resp. increases) by one when passing a critical point of index 1 (resp. $n - 1$). Hence $1 \leq \max_{\tau} \{\text{Rank}(H_0(f^{-1}(\tau)))\} \leq 1 + \#\text{Crit}_{n-1}(f)$.

It follows that in the case of one minimum and one maximum, all α_j as above are surjective if all the critical points of index 1 lie below the critical points of index $n - 1$, in which case we also have that all α_i 's as above are surjective. This is e.g. the case for $f : \mathbb{R}\mathbb{P}^n \rightarrow \mathbb{R}; (x_1, \dots, x_{n+1}) \mapsto \sum c_i x_i^2 / |x|^2$ where $c_i < c_{i+1}$ (see [Mat02]). Moreover, since the above method generalizes to the case of more than one critical point ([Mil65],p.35) we have

3.17 Corollary.

If $f : M \rightarrow \mathbb{R}$ is a self indexing Morse function with one minimum and one maximum and $\dim M > 2$ then $\beta_0(f^{-1}(t)) = 1$ for all $t \in \mathbb{R}$.

Now if $\alpha_j = 0$ for some α_j (and critical point a_j as above) then it must be the case that there exists a critical point a_i with $\lambda_{a_i} = 1$ such that $f(a_j) < f(a_i)$ i.e. a_i lies above a_j , hence $W(a_j, a_i) = \emptyset$, and $\alpha_i = 0$. The above is e.g. the case when there exists an elementary cobordism W_j as above which is simply connected.

As a passing remark note that we could obtain the conclusion of corollary 3.15 by the above arguments since, in these cases, \mathbb{Z} is replaced by 0 in the above diagrams.

We could now proceed by investigating when (and under what conditions) the inclusions, inducing α and α' , are zero or surjective. However, we choose to change the above approach slightly and follow ([Bro72],Ch.IV). Let (W_i, V_i, V'_i) be the elementary cobordism above. We may describe V'_i as being the result of doing surgery (of type $(1, n-1)$) on V_i as follows. Let $E = \mathbb{S}^0 \times \mathbb{D}^{n-1}$ and $\varphi : E \rightarrow V_i$ the characteristic embedding ([Mil65],p.28) i.e. a smooth embedding into the interior of V_i , then V'_i is homeomorphic to $(V_i - \text{int}\varphi(E)) \cup_{\mathbb{S}^0 \times \mathbb{S}^{n-2}} (\mathbb{D}^1 \times \mathbb{S}^{n-2})$ where int denote the interior (compare ([Mil65],p.31)).

3.18 Remark: A cobordism between V_i and V'_i can be obtained as $W = (V_i \times [0, 1]) \cup_{\mathbb{S}^0 \times \mathbb{D}^{n-1}} (\mathbb{D}^1 \times \mathbb{D}^{n-1})$ with $(x, y) \in \mathbb{S}^0 \times \mathbb{D}^{n-1}$ identified with $(\varphi(x, y), 1)$. Note that W is the result of attaching a 1-handle to $V_i \times [0, 1]$ (see appendix 1.3.1, ([Bro72],p.83) and compare ([Mil65],p.31)). ■

Now let $M_0 = V_i - \text{int}\varphi(E)$ then by ([Bro72],p.98) we have

$$0 \longrightarrow \mathbf{H}_1(M_0) \longrightarrow \mathbf{H}_1(V'_i) \xrightarrow{y} \mathbb{Z} \longrightarrow \mathbf{H}_0(M_0) \longrightarrow \mathbf{H}_0(V'_i) \longrightarrow 0$$

where $z \mapsto y \cdot z$ is the map induced by the intersection product, $y = \psi_*(\mu')$, $\psi : E' = \mathbb{D}^1 \times \mathbb{S}^{n-2} \rightarrow V'_i$ the natural (smooth) embedding, $\mu' = i'_*([\mathbb{S}^{n-2}])$, $i : \mathbb{S}^{n-2} \hookrightarrow E' = \mathbb{D}^1 \times \mathbb{S}^{n-2}$ the inclusion, and $[\mathbb{S}^{n-2}] \in \mathbf{H}_{n-s}(\mathbb{S}^{n-2})$ the fundamental class. Note that if we consider E' as a 1-disc bundle over \mathbb{S}^{n-2} then $\mu' = \tau \cap [E']$ with $\tau = D_{E'}(i'_*([\mathbb{S}^{n-2}]))$ the Thom class and where $D_{E'} : \mathbf{H}_{n-2}(E') \rightarrow \mathbf{H}^1(E', \partial E')$ is the inverse to $\cap[E']$ the Poincaré map.

We want to replace $\mathbf{H}_0(M_0)$ with $\mathbf{H}_0(V_i)$ in the above sequence. This is possible since $\mathbf{H}_0(V_i, M_0) \approx \mathbf{H}_0(E, \partial E) \approx 0$ where the first isomorphism is excision and the second is by the long exact sequence for $(E, \partial E)$. Hence $\mathbf{H}_0(M_0) \approx \mathbf{H}_0(V_i)$ by the long exact sequence for (V_i, M_0) , so

$$0 \longrightarrow \mathbf{H}_1(M_0) \longrightarrow \mathbf{H}_1(V'_i) \xrightarrow{y} \mathbb{Z} \longrightarrow \mathbf{H}_0(V_i) \longrightarrow \mathbf{H}_0(V'_i) \longrightarrow 0$$

is exact and $z \mapsto y \cdot z$ is either zero or surjective. Moreover, arguments similar to the above apply to (W_j, V_j, V'_j) and we obtain an exact sequence

$$0 \longrightarrow \mathbf{H}_1(M_0) \longrightarrow \mathbf{H}_1(V'_j) \xrightarrow{x} \mathbb{Z} \longrightarrow \mathbf{H}_0(V'_j) \longrightarrow \mathbf{H}_0(V_j) \longrightarrow 0$$

where $x = \varphi_*(\mu)$, $\varphi : \mathbb{S}^{n-2} \times \mathbb{D}^1 \rightarrow V_j$ is the characteristic embedding and $\mu = i_*([\mathbb{S}^{n-2}])$ is as above. Hence we obtain the same conclusion as above, that

the number of path components of a level surfaces either remains constant or reduces (resp. increases) by one when passing a critical point of index 1 (resp. $n - 1$). But we now know a bit more about the maps determining this behavior. We end this appendix with a list of some special cases.

- 1) If there are no critical points of index $n - 1$ below V_j then it is connected. So $\mathbb{H}_{n-2}(V_j)$ has no torsion (corollary VI.7.13 in [Bre93]) since all level surfaces are orientable. Hence $x = 0$ iff $z \mapsto x \cdot z$ is zero (lemma 4.35 in [Mat02]).
- 2) Let $\mathbb{S} = \varphi(\mathbb{S}^{n-2})$ (identifying $\mathbb{S}^{n-2} \approx \mathbb{S}^{n-2} \times \{*\}$) and assume that $\mathbb{S} \subset V_j$ bounds $\mathbb{D} \subset V_j$ an embedded copy of \mathbb{D}^{n-1} . It is clear that there exists a singular $n - 2$ simplex $c : \Delta^{n-2} \rightarrow \mathbb{S}$ (collapsing $\partial\Delta^{n-2}$ to a point), and a singular $n - 1$ simplex $b : \Delta^{n-1} \rightarrow \mathbb{D}$ such that $c = \partial b$. Hence $x = \varphi_*([\mathbb{S}^{n-2}]) = 0$ (using that $i : \mathbb{S}^{n-2} \hookrightarrow \mathbb{S}^{n-2} \times \mathbb{D}^1$ induces an isomorphism in homology).
- 3) Let S be a closed 1-manifold (i.e. a finite union of circles) embedded in V_j intersecting \mathbb{S} transversely in a finite number of points, then $[\mathbb{S}] \cdot [S] = \langle \mathbb{S} \rangle \cdot \langle S \rangle$ where the right hand side is the intersection number (see ([Mat02],p.159)). So if there exists S such that $S \cap \mathbb{S} = \{*\}$ then $z \mapsto x \cdot z$ is surjective.
- 4) Let the critical points be arranged as in (3.1). If $\lambda_{a_1} = n - 1$ then $z \mapsto x \cdot z$ is zero since $V_j \approx \mathbb{S}^{n-1}$.
- 5) Let the critical points be arranged as in (3.1). Let a_i be the first critical point of index $n - 1$. If there are no critical points of index 2 below a_i the map $z \mapsto x \cdot z$ is zero since all level surfaces below a_i are simply connected. This follows by a simple computation using the long exact sequences of pairs (W_i, V_i) and (W_i, V'_i) .

Chapter 4

Path components and the space of broken flow lines

In this chapter we address the question of whether or not compactifying the space of height-parameterized flow lines alters the number of path components of this space.

As always we fix a Morse function $f : M \rightarrow \mathbb{R}$ on a closed n -manifold M and a Riemannian metric g on M such that the pair (f, g) is Morse-Smale. Through the course of this chapter additional assumptions on f and g will be made. These are as follows: f must be self indexing with only one minimum and one maximum, and g must be compatible with the Morse charts (we refer the reader to the last part of section 3.1 and remark 4.5 for comments on these assumptions).

In section 4.1 we construct a gluing procedure for height-parameterized flow lines. This is a local construction that relies on data contained in the normal bundle $\nu(W(p, q)^\tau, W^u(p)^\tau)$. In section 4.2 we use the gluing procedure to show that the inclusion of the space of height-parameterized flow lines into the space of broken flow lines induces a surjection on π_0 (the 0'th homotopy group) i.e. no path component of the space of broken flow lines consists only of broken flow lines.

In section 4.3 we show that adding flow lines which only break once to the space of height-parameterized flow lines does not alter the number of path components

of this space (for a precise statement see lemma 4.11). Moreover, in the case of $\dim(M) = 3$ we show that the inclusion of the space of height-parameterized flow lines into the space of broken flow lines induces a bijection on π_0 , hence compactifying the space of height-parameterized flow lines does not alter the number of path components. In section 4.4 we extend the result of section 4.3 to include flow lines which break at critical points of either index $n - 1$ and $n - 2$, or index 2 and 1 (for a precise statement see lemma 4.14).

4.1 A gluing construction

The aim of this section is to construct a gluing map. This construction will rely on the following observation regarding the normal bundle $\nu(W(p, q)^\tau, W^u(p)^\tau)$.

4.1 Claim.

We have $\nu(W(p, q)^\tau, W^u(p)^\tau) \approx W(p, q)^\tau \times \mathbb{E}_q^u$. That is, the $(\lambda_p - 1)$ -dimensional normal bundle of $W(p, q)^\tau$ in $W^u(p)^\tau$ is trivial with fiber the unstable summand \mathbb{E}_q^u in $T_q M = \mathbb{E}_q^u \oplus \mathbb{E}_q^s$.

Proof:

The statement will follow from standard transversality arguments. Let A and B be submanifolds of M , we will show that $T_C M \approx \nu(C, A) \oplus TC \oplus \nu(C, B)$ whenever $C = A \pitchfork B$ i.e. A and B are transverse. First

$$C = A \pitchfork B \Leftrightarrow 0 \rightarrow TC \xrightarrow{i} T_C A \oplus T_C B \xrightarrow{j} T_C M \rightarrow 0 \text{ is exact}$$

where $i : z \mapsto (z, z)$ and $j : (x, y) \mapsto x - y$. Now with the identification $T_C A \oplus T_C B = TC \oplus \nu(C, A) \oplus TC \oplus \nu(C, B) : (x, y) = (x_c, x_a; y_c, y_b)$ we have, for i , a splitting map $s : (x_c, x_a; y_c, y_b) \mapsto x_c$ (one could also choose y_c instead of x_c). Hence¹ there exists an idempotent endomorphism $\varphi = i \circ s : (x_c, x_a; y_c, y_b) \mapsto (x_c, 0; x_c, 0)$ such that $\ker(\varphi) = \text{im}(\mathbf{1} - \varphi)$, $\text{im}(\varphi) = \text{im}(i)$ and $T_C A \oplus T_C B = \text{im}(\mathbf{1} - \varphi) \oplus \text{im}(\varphi) = \ker(\varphi) \oplus \text{im}(\varphi)$. Since $\text{im}(i) = \ker(j)$ this implies that

$$\begin{aligned} T_C A \oplus T_C B &= \ker(\varphi) \oplus \text{im}(\varphi) \stackrel{j \oplus s}{\approx} T_C M \oplus TC \\ (x_c, x_a; y_c, y_b) &= (0, x_a; y_c, y_b : x_c, 0; x_c, 0) \approx (x_a - y : x_c) \end{aligned}$$

Hence $T_C M \approx \ker(\varphi) = \nu(C, A) \oplus TC \oplus \nu(C, B)$ and so $T_C M \approx \nu(C, A) \oplus T_C B$ which implies $\nu(C, A) \approx_C \nu(B, M)$ where \approx_C denote isomorphism over C .

¹See ([Bre93], p.179-180)

Now with $A = W^u(p)^\tau$, $B = W^s(q)^\tau$ and $M = M^\tau$ we have $C = W(p, q)^\tau$ and $\nu(W(p, q)^\tau, W^u(p)^\tau) \approx_C \nu(W^s(q)^\tau, M^\tau)$. Moreover, with $A = M^\tau$, $B = W^s(q)$ and $M = M$ we have $C = W^s(q)^\tau$ and $\nu(W^s(q)^\tau, M^\tau) \approx_C \nu(W^s(q), M)$. Since $\nu(W^s(b), M)$ is an λ_b -dimensional vector bundle over $W^s(b)$ which is contractible we have, with $C = W(p, q)^\tau$ and $C' = W^s(q)^\tau$

$$\begin{aligned} \nu(W(p, q)^\tau, W^u(p)^\tau) &\approx_C \nu(W^s(q)^\tau, M^\tau) \\ &\approx_{C'} \nu(W^s(q), M) \approx W^s(q) \times \nu(W^s(q), M)_x \end{aligned} \quad (4.1)$$

where $\nu(W^s(b), M)_x$ is the fiber over $x \in W^s(b)$. Note that (4.1) implies that

$$\nu(W(p, q)^\tau, W^u(p)^\tau) \approx W(p, q)^\tau \times \nu(W^s(q), M)_x$$

with $x \in W(p, q)^\tau$. Moreover, by theorem 1.1 and since $T_{W^s(q)}M \approx \nu(W^s(q), M) \oplus TW^s(q)$ we have

$$\mathbb{E}_q^u \oplus \mathbb{E}_q^s = T_q M \approx \nu_q(W^s(q), M) \oplus T_q W^s(q) \approx \nu_q(W^s(q), M) \oplus \mathbb{E}_q^s$$

with all isomorphisms in **Vect** the category of vector spaces. So by identifying each fiber of $\nu(W^s(q), M)$ with \mathbb{E}_q^u we have $\nu(W(p, q)^\tau, W^u(p)^\tau) \approx W(p, q)^\tau \times \mathbb{E}_q^u$, proving the claim. \square

We now begin the construction of a continuous (gluing) map $[0, \varepsilon] \rightarrow \overline{M}(p, q)$; $s \mapsto G(\eta_1, \eta_2; s)$, with $\eta_1 \in M(q, a)$ and $\eta_2 \in M(a, p)$ fixed, such that $G(\eta_1, \eta_2; s) \in M(p, q)$ for $s \neq 0$, and $G(\eta_1, \eta_2; 0) = \eta_1 \# \eta_2 \in \overline{M}(p, q)$. That is, the gluing map associates to each strictly positive (gluing) parameter a non broken flow line and at zero gives the broken flow line $\eta_1 \# \eta_2$.

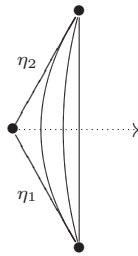

Figure 4.1: An illustration of the gluing procedure, where \bullet denote the critical points q , a and p listed from below, $-$ denote orbits, and the dotted arrow indicate the increase in $s \in [0, \varepsilon]$.

Let $\nu^S(\mathbb{W}(p, q)^\tau, \mathbb{W}^u(p)^\tau)$ denote the unit sphere bundle in $\nu(\mathbb{W}(p, q)^\tau, \mathbb{W}^u(p)^\tau)$ that is $\nu^S(\mathbb{W}(p, q)^\tau, \mathbb{W}^u(p)^\tau) \approx \mathbb{W}(p, q)^\tau \times \mathbb{S}_q^u$. Now for $m \in \mathbb{W}(p, q)^\tau$ let $\exp_m : \bar{T}_m \mathbb{W}^u(p)^\tau \rightarrow \mathbb{W}^u(p)^\tau$ denote the exponential map at m , where $\bar{T}_m \mathbb{W}^u(p)^\tau \subseteq T_m \mathbb{W}^u(p)^\tau$ denotes the domain of \exp_m , with equality if there are no critical points between p and q .

For $\varepsilon = \iota(m) > 0$, where $\iota(m)$ denote the injectivity radius ([Kli95], p.131) wrt. \exp_m , and $I = [0, \varepsilon]$, we then define a continuous map Exp_m by the composition

$$\begin{aligned} \nu_m^S(\mathbb{W}(p, q)^\tau, \mathbb{W}^u(p)^\tau) \times I &\rightarrow \nu_m(\mathbb{W}(p, q)^\tau, \mathbb{W}^u(p)^\tau) \hookrightarrow \bar{T}_m \mathbb{W}^u(p)^\tau \xrightarrow{\exp_m} \mathbb{W}^u(p)^\tau \\ (m; y, s) &\mapsto (m; sy) \mapsto \exp_m(sy) \end{aligned}$$

Note that for $s \neq 0$ the map Exp_m defines a diffeomorphism onto $\text{im}(\exp_m) - \{m\}$ and the curve $I \rightarrow \mathbb{W}^u(p)^\tau; s \mapsto \text{Exp}_m(x, s)$ is a geodesic.

Let (U_q, ψ) be a Morse chart around q and assume that the Riemannian metric \mathbf{g} is compatible with (U_q, ψ) . Hence $\text{im}(\psi) = \mathbb{E} = \mathbb{E}_q^u \oplus \mathbb{E}_q^s$ and $\psi \circ \varphi_t \circ \psi^{-1}(x, y) = (xe^{2t}, ye^{-2t})$. Let $\mathbb{E}^\tau = \mathbb{E} \cap \psi(f^{-1}(\tau))$ and choose τ and κ such that $(\mathbb{E}_q^s)^\tau = \mathbb{S}_q^s$ and $(\mathbb{E}_q^u)^\kappa = \mathbb{S}_q^u$. By direct calculations it is then easily verified that the involution

$$F : \mathbb{E}^\tau - (\mathbb{S}_q^s) \xrightarrow{\approx} \mathbb{E}^\kappa - (\mathbb{S}_q^u); (x, y) \mapsto (|y|x/|x|, |x|y/|y|) \quad (4.2)$$

has the property that (x, y) and $F(x, y)$ lie on the same local flow line.

Fix $(m^0; x^0) = (m^0; x_u^0, 0) \in \nu^S(\mathbb{W}(p, q)^\tau, \mathbb{W}^u(p)^\tau)$, let $\psi(m^0) = y^0 = (0, y_s^0)$ and note that $|y^0| = 1$ since $\psi(\mathbb{W}(p, q)^\tau) \subset \mathbb{S}_q^s$. With $I' =]0, \varepsilon]$ we then define the following local curves

$$\begin{aligned} I &\rightarrow \mathbb{E}^\tau; s \mapsto \psi(\text{Exp}_{m^0}(x^0, s)) = (x(s), y(s)) \\ I' &\rightarrow \mathbb{E}^\kappa; s \mapsto (u(s), v(s)) = F(\psi(\text{Exp}_{m^0}(x^0, s))) \\ &= (|y(s)|x(s)/|x(s)|, |x(s)|y(s)/|y(s)|) \end{aligned}$$

Observe that

$$(\dot{x}(0), \dot{y}(0)) = \left. \frac{d}{dt} \right|_{s=0} \psi(\text{Exp}_{m^0}(x^0, s)) = x^0 = (x_u^0, 0)$$

and for $s \rightarrow 0$ we have

$$\begin{aligned} (x(s), y(s)) &\rightarrow (x(0), y(0)) = (0, y_s^0) \\ v(s) &\rightarrow 0 \quad \text{and} \quad |y(s)| \rightarrow 1 \end{aligned}$$

Moreover, $u_1(s) = x(s)/|x(s)| \rightarrow \mathbf{x}_u^0 \in \mathbb{S}_q^u$ as $s \rightarrow 0$ since $u_1(s) \in \mathbb{S}_q^u$ for all $s \in I$, hence

$$(u(s), v(s)) \rightarrow \mathbf{x}^0 = (\mathbf{x}_u^0, 0) \quad \text{for } s \rightarrow 0$$

and so we extend $s \mapsto (u(s), v(s))$ to a continuous map on I .

4.2 Claim.

With notation as above we have $\mathbf{x}^0 = x^0$.

Proof:

We just calculate the right-hand derivative

$$\dot{x}^+(0)/|\dot{x}^+(0)| = \frac{\lim_{s \rightarrow 0^+} x(s)/s}{|\lim_{s \rightarrow 0^+} x(s)/s|} = \lim_{s \rightarrow 0^+} \frac{x(s)/s}{|x(s)/s|} = \lim_{s \rightarrow 0^+} x(s)/|x(s)| = \mathbf{x}_u^0$$

But the right and left-hand derivative are the same since $s \mapsto x(s)$ is smooth (meaning, by definition, that this map extends to a smooth map on $] -\delta, \varepsilon + \delta[$ for some $\delta > 0$). Hence $\mathbf{x}_u^0 = \dot{x}(0)/|\dot{x}(0)| = x_u^0/|x_u^0| = x_u^0$, proving the claim. \square

We can now prove our version of the gluing lemma, we refer to figure 4.2 for an illustration of the proof.

4.3 Lemma.

Let $f : M \rightarrow \mathbb{R}$ be a Morse function on a Riemannian manifold (M, \mathbf{g}) such that (f, \mathbf{g}) is Morse-Smale and \mathbf{g} is compatible with the Morse charts. Given $p, a, q \in \text{Crit}(f)$ with $\lambda_p > \lambda_a > \lambda_q = 0$, and let $\eta_1 \in M(q, a)$ and $\eta_2 \in M(a, p)$. For $\varepsilon > 0$ small there exists a continuous map $[0, \varepsilon] \rightarrow \overline{M}(q, p); s \mapsto G(\eta_1, \eta_2; s) = \eta_1 \#_s \eta_2$ such that $\eta_1 \#_0 \eta_2 = \eta_1 \# \eta_2$ and $\eta_1 \#_s \eta_2 \in M(q, p)$ for $s > 0$.

Proof:

With notation as above let $\eta_2(\tau) = m^0 \in W(p, a)^\tau$, $\eta_1(\kappa) = m^1 \in W(a, q)^\kappa$, $\psi(m^1) = x^0$ and $\eta : [f(q), f(p)] \times W(p, q) \rightarrow M$ be the continuous “flow” map defined below claim 2.5.

By claim (4.2) we have $\psi^{-1}(u(0), v(0)) = m^1 \in W^s(q)^\kappa$. Now $W^s(q)^\kappa$ is open in M^κ because $\lambda_q = 0$, hence $\text{im}(\psi^{-1}(u(s), v(s))) \subset W^s(q)^\kappa$ for all $s \in [0, \varepsilon]$ where ε is chosen smaller than $\iota(m^0)$ if necessary. From the above we then conclude that

- 1) $\psi^{-1}(F(\psi(\text{Exp}_{m^0}(x^0, t))))$ and $\text{Exp}_{m^0}(x^0, t)$ belong to the same flow line for each $t \in I'$

- 2) For $t \in I'$, both $\psi^{-1}(F(\psi(\text{Exp}_{m^0}(x^0, t))))$ and $\text{Exp}_{m^0}(x^0, t)$ belong to $W(p, q)$.
- 3) $\psi^{-1}(F(\psi(\text{Exp}_{m^0}(x^0, 0)))) = m^1 \in W(a, q)$ and $\text{Exp}_{m^0}(x^0, 0) = m^0 \in W(p, a)$.

Now let $\eta : [f(q), f(p)] \times W(p, q) \rightarrow M$ be the continuous “flow” map defined below claim 2.5. Then by (1) and (2) above we have a well defined map

$$]0, \varepsilon] \rightarrow M(q, p); s \mapsto G(s) = G(\eta_1, \eta_2; s) = \begin{cases} t \mapsto \eta_g(\text{Exp}_{m^0}(x^0, s))(t) & t \in J(q, a) \\ t \mapsto \eta_{\text{Exp}_{m^0}(x^0, s)}(t) & t \in J(a, p) \end{cases}$$

with $J(q, a) = [f(q), f(a)]$, $J(a, p) = [f(a), f(p)]$ and $g = \psi^{-1} \circ F \circ \psi$. Moreover, it is clear that G is continuous and by (3) above that $\lim_{s \rightarrow 0} G(s) = \eta_{m^1} \# \eta_{m^0} = \eta_1 \# \eta_2$. Hence we may extend G to a continuous map $[0, \varepsilon] \rightarrow \overline{M}(q, p)$ which is the required map. \square

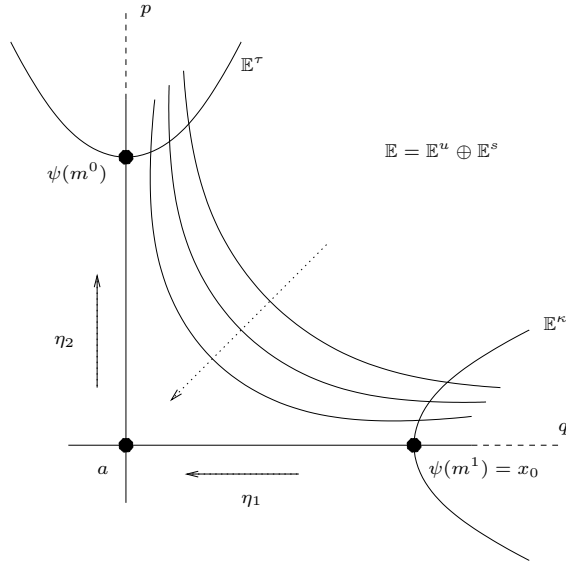

Figure 4.2: The gluing construction of lemma 4.3.

Note that the gluing map G is a continuous curve with no self intersections, hence injective. Moreover, since $[0, \varepsilon]$ is compact and $\overline{M}(q, p)$ is Hausdorff we have the following.

4.4 Corollary.

The gluing map is an embedding.

4.5 Remark: Note that we can not talk about G as a C^r ($r > 0$) map since $\overline{M}(q, p)$ does not carry any C^r structure.² However if we restrict G to $]0, \varepsilon]$ then $\text{im}(G) \subset M(q, p)$, and so using the evaluation map e_τ say to identify $M(q, p)$ with $W(p, q)^\tau$ (according to claim 2.9) we see that $G(s) = \text{Exp}_{m^0}(x^0, s)$. Hence $G|]0, \varepsilon]$ is a diffeomorphism onto its image in this case.

Moreover, the compatibility condition on \mathfrak{g} in lemma 4.3 is not severe, since any metric can be modified to be compatible with the Morse charts (see page 7).

Finally, the gluing map G above should be compared to the gluing constructions mentioned at the beginning of appendix 2.5.1. ■

4.1.1 Extension of the gluing map

In this subsection we show how one may extend the gluing map G from lemma 4.3 to a (continuous) map $M(q, a) \times D \rightarrow \overline{M}(q, p)$, where $D \subseteq M(a, p) \times \mathbb{R}^+$ and $\mathbb{R}^+ = [0, \infty[$. This result is not used elsewhere.

Let $\overline{TW}^u(p)^\tau \subset TW^u(p)^\tau$ be the domain of exp , and consider the homeomorphism

$$M(q, a) \times M(a, p) \xrightarrow{\cong} W(p, a)^\tau \times W(a, q)^\kappa \xrightarrow{\cong} W(p, a)^\tau \times \mathbb{S}_{a, q}^u, \quad \mathbb{S}_{a, q}^u \subseteq \mathbb{S}_a^u$$

where the first map is $(e_\tau \circ \text{pr}_2, e_\kappa \circ \text{pr}_1)$ and the second map is $\mathbf{1} \times \psi$ with $\psi(W(a, q)^\kappa) = \mathbb{S}_{a, q}^u$. Now with $D = \{(\eta, s) \in M(a, p) \times \mathbb{R}^+ \mid s \in [0, \iota(e_\tau(\eta))]\}$ ³ the following composition is well defined

$$\begin{aligned} \text{Exp} : M(q, a) \times D &\rightarrow \nu^S(W(p, a)^\tau, W^u(p)^\tau) \times \mathbb{R}^+ \rightarrow \overline{TW}^u(p)^\tau \xrightarrow{\text{exp}} W^u(p)^\tau \\ (\eta_1, \eta_2, s) &\mapsto (e_\tau(\eta_2), \psi(e_\kappa(\eta_1)), s) \mapsto (e_\tau(\eta_2), \psi(e_\kappa(\eta_1))s) \\ &\mapsto \text{exp}_{e_\tau(\eta_2)}(\psi(e_\kappa(\eta_1))s) \end{aligned}$$

where we have used the identification $\nu^S(W(p, a)^\tau, W^u(p)^\tau) \approx W(p, a)^\tau \times \mathbb{S}_a^u$ of claim 4.1. It is clear that Exp is continuous. Moreover, by replacing the constants $x^0 = \psi(\eta_1(\kappa))$ and $m^0 = \eta_2(\tau)$ in the above construction of G , with

²If this property is wanted one has to proceed along the lines mentioned in remark 2.7.

³Just as a passing remark, recall that ι the injectivity radius is a continuous function ([Kli95], p.131).

the continuous functions $\eta_1 \mapsto x^0(\eta_1) = \psi \circ e_\kappa(\eta_1)$ and $\eta_2 \mapsto m^0(\eta_2) = e_\tau(\eta_2)$ respectively, one sees that the map

$$M(q, a) \times D \rightarrow \overline{M}(q, p); (\eta_1, \eta_2; s) \mapsto \begin{cases} t \mapsto \eta_{g(\text{Exp}(\eta_1, \eta_2; s))}(t) & t \in [f(q), f(a)] \\ t \mapsto \eta_{\text{Exp}(\eta_1, \eta_2; s)}(t) & t \in [f(a), f(p)] \end{cases}$$

with $g = \psi^{-1} \circ F \circ \psi$, is well defined and continuous (after extension to $s = 0$, as above). By abuse of notation we denote this map by G and write $G(\eta_1, \eta_2; s) = \eta_1 \#_s \eta_2$. As above we have that $G(\eta_1, \eta_2; 0)$ is the height-parameterized flow line $\eta_{e_\kappa(\eta_1)} \# \eta_{e_\tau(\eta_2)} = \eta_1 \# \eta_2$, and for $s \neq 0$ that $G(\eta_1, \eta_2; s)$ is the height-parameterized flow line through $\text{Exp}(\eta_1, \eta_2; s) \in W(p, q)^\tau$ (or equivalently, through $g(\text{Exp}(\eta_1, \eta_2; s)) \in W(p, q)^\kappa$)

As a passing remark we note that if the injectivity radius $\iota(W(p, a)^\tau)$ is positive and $s \neq 0$ then G is a homeomorphism onto its image.

4.2 Surjectivity of $M(q, p) \hookrightarrow \overline{M}(q, p)$ on π_0

In this section we show, by means of the gluing map, how one may continuously deform any broken flow line into a height-parametrized flow line. As a corollary of this construction we show that the inclusion $M(q, p) \hookrightarrow \overline{M}(q, p)$ induces a surjection on π_0 (the 0'th homotopy group), hence we obtain an upper bound for the number of path components of $\overline{M}(q, p)$.

4.6 Theorem.

Let $f : M \rightarrow \mathbb{R}$ be a Morse function on a Riemannian manifold (M, \mathbf{g}) such that (f, \mathbf{g}) is Morse-Smale and \mathbf{g} is compatible with the Morse charts. If $\beta = \eta_1 \# \cdots \# \eta_k \in \overline{M}(q, p)$ with $\lambda_q = 0$ and $\lambda_p = n$, then there exists $\eta \in M(q, p)$, an $\varepsilon > 0$ and a path $p \in C([0, \varepsilon], 0, \varepsilon, (\overline{M}(q, p), \beta, \eta))$. Moreover, if $\mathbf{b}(s)$ denotes the (strict) chain connected to $p(s)$ then $s \mapsto l(\mathbf{b}(s))$ is a decreasing function from k to 1.

Proof:

Let $\mathbf{b}(0) = \{q = b_0, b_1, \dots, b_{k-1}, b_k = p\}$ denote the chain connected to β , and $p_1 : [0, \varepsilon_1[\rightarrow \overline{M}(q, p)$ be the path defined as the composition of the continuous maps $[0, \varepsilon_1[\rightarrow \overline{M}(q, b_2); s \mapsto \eta_1 \#_s \eta_2$, and $\overline{M}(q, b_2) \rightarrow \overline{M}(q, p); \alpha \mapsto \alpha \# \eta_3 \# \cdots \# \eta_k$ the partial map of the concatenation map $\overline{M}(q, b_2) \times \overline{M}(b_2, p) \rightarrow \overline{M}(q, p); (\alpha, \nu) \mapsto \alpha \# \nu$. Hence p_1 is continuous, $p_1(s) = \eta_1 \#_s \eta_2 \# \eta_3 \# \cdots \# \eta_k$ and $p_1(0) = \beta$.

Now fix $s_1 \in]0, \varepsilon_1[$ and let $\mathbf{b}(s_1) = \{q = b_0, b_2, \dots, b_{k-1}, b_k = p\}$ denote the chain connected to $p_1(s_1)$. Proceeding as above we obtain a continuous path $p_2 : [0, \varepsilon_2[\rightarrow \overline{M}(q, p)$; $s \mapsto \eta_1 \#_{s_1} \eta_2 \#_s \eta_3 \# \dots \# \eta_k$ with $p_2(0) = p_1(s_1)$.

If we proceed $k - 1$ times we obtain, for $i = 1, \dots, k - 1$, continuous paths $p_i : [0, \varepsilon_i[\rightarrow \overline{M}(q, p)$ such that $p_{i+1}(0) = p_i(s_i)$, $p_1(0) = \beta$ and $p_{k-1}(s) \in M(q, p)$ for $s > 0$. Let $\varepsilon = \min\{s_i\}$, we may then assume that $\text{dom}(p_i) = [0, \varepsilon]$ for all i . Moreover, by replacing each s_i by ε in the above we may define $p : [0, \varepsilon] \rightarrow \overline{M}(q, p)$ by $p = p_1 \# p_2 \# \dots \# p_{k-1}$ i.e.

$$p(s) = p_i((k-1)s - (i-1)\varepsilon) = \eta_1 \#_\varepsilon \eta_2 \#_\varepsilon \dots \#_\varepsilon \eta_i \#_{(k-1)s - (i-1)\varepsilon} \eta_{i+1} \# \dots \# \eta_k$$

on $[(i-1)\varepsilon/(k-1), i\varepsilon/(k-1)]$ for $i = 1, \dots, k-1$. Moreover, by the above construction $l(\mathbf{b}(s))$ is k for $s = 0$ and $k - i$ on $](i-1)\varepsilon/(k-1), i\varepsilon/(k-1)]$ for $i = 1, \dots, k-1$, hence proving the theorem. \square

We make the following observation regarding the construction of the path p . Let notation be as above and consider (as always w.r.t. the uniform metric d_∞) the open r -ball $\mathbf{B}_r(\beta)$ in $\overline{M}(q, p)$ centered at β . Since the function $s \mapsto d_\infty(\beta, p(s))$ is continuous (mapping 0 to 0) we see from the above construction of p that, given $r > 0$ we may assume that $p(s) \in \mathbf{B}_r(\beta)$ for all $s \in [0, \varepsilon]$ by choosing ε sufficiently small.

Let $\tau \in]f(q), f(p)[$ and $\#S$ denote the number of path components of the space S . We then note that $\#W(p, q) = \#W(p, q)^\tau = \#M(q, p)$ since $W(p, q) \simeq W(p, q)^\tau \approx M(q, p)$ (see above diagram (2.2)) so their homology agrees. In particular $\#W(p, q)^\tau$ does not depend on τ . Moreover, by theorem 4.6 above, we may connect any broken flow line to a non broken flow line by a continuous path. Hence we conclude that there are no path component of $\overline{M}(q, p)$ consisting only of broken flow lines.

Now let $W \subset W(p, q)^\tau$ denote a path component and $x, y \in W$, hence there exists a path $\rho \in C([0, 1], 0, 1, (W, x, y))$. Let $\eta : [f(q), f(p)] \times W(p, q) \rightarrow M$ be the continuous ‘‘flow’’ map defined below claim 2.5, then $[0, 1] \rightarrow M(q, p) \subset \overline{M}(q, p)$; $s \mapsto \eta_{\rho(s)}$ defines a continuous map. Hence each path component of $M(q, p)$ is contained in a path component of $\overline{M}(q, p)$ i.e.

4.7 Corollary.

The inclusion $M(q, p) \hookrightarrow \overline{M}(q, p)$ induces a surjection on π_0 . So $\#\overline{M}(q, p) \leq \#M(q, p)$ in particular.

4.8 Remark: Note that in theory it could be that $\#M(q, p)$ is infinite. However we believe that this is not the case. Moreover, if $\dim(M) = 2$ (or $= 3$) then

$\#M(q, p)$ is finite by the proof of the Morse homology theorem (resp. by (5.3) of chapter 5). \blacksquare

The obvious question is now whether or not path components of $M(q, p)$ remain disjoint when $M(q, p)$ is included in $\overline{M}(q, p)$ i.e. can it happen that two (or more) path components of $M(q, p)$ are merged under the inclusion, by means of broken flow lines, to form only one path component in $\overline{M}(q, p)$. In the next two sections we give a partial answer to this question.

4.3 On the injectivity of $M(q, p) \hookrightarrow \overline{M}(q, p)$ on π_0

In this section we show that the number of path components remains constant when we add to $M(q, p)$ the set of broken flow lines which only break once (for a precise statement see lemma 4.11). Moreover, in the three dimensional case ($\dim(\mathbf{M}) = 3$) we show that the inclusion $M(q, p) \hookrightarrow \overline{M}(q, p)$ induces a bijection on π_0 , hence $\#\overline{M}(q, p) = \#M(q, p)$ in this case. The results/techniques of this section are also used in section 4.4.

We assume that f is self indexing with one minimum q and one maximum p . Throughout let $I = [0, 1]$, $J = [f(q), f(p)]$, b denote a critical point of index $n - 1$, and $\rho \in C((I, 0, 1), (\overline{M}(q, p), \eta, \eta'))$ with $\eta, \eta' \in M(q, p)$. Finally, for fixed $\tau \in J$ we let $p_\tau : I \rightarrow \mathbf{M}^\tau$ denote the map $s \mapsto p_\tau(s) = \rho(s)(\tau)$ and call this the induced level τ -map.

Let W denote one of the (un)stable manifolds. Since W is contractible (being diffeomorphic to an open disk) we conclude that any vector bundle over W is trivial (see ([Hus75],p.29) or ([Hir94],p.97)) and orientable (see ([Hir94],p.104)). As in section 4.1 let $\nu(W^u(b), \mathbf{M}) \approx W^u(b) \times \mathbb{R}$ denote the orientable one dimensional normal bundle of $W^u(b)$ in \mathbf{M} , and $T_b \subset \nu(W^u(b), \mathbf{M})$ a normal tubular neighborhood of $W^u(b)$ which we (as usual) identify with an open neighborhood of $W^u(b)$ in \mathbf{M} .

Since $\nu(W^u(b), \mathbf{M})$ is orientable we say that $(x, u) \in T_b$ is on the positive side of $W^u(b)$ if $u > 0$, i.e. the normal coordinate is strictly positive.

Fix $\tau \in J$ and let $I' =]s_1, s_2[$ be an open connected interval such that $p(s) = p_\tau(s) \in T_b$ for all $s \in I'$ and some b . We assume that I' is maximal (wrt. p) in the sense that there exists no other open connected interval I'' such that $I' \subset I''$ and $p(s) \in T_b$ for all $s \in I''$. On I' we write $p(s) = (x(s), u(s))$.

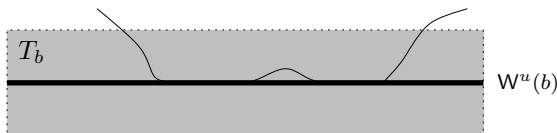

Figure 4.3: The image of $s \mapsto p(s)$ on a neighborhood of I' .

Now assume that p crosses $W^u(b)$ i.e. there exists an $\varepsilon > 0$ and a closed interval $I'' = [s'_1, s'_2] \subset I'$ such that $u = 0$ on I'' , $u > 0$ on $]s'_1 - \varepsilon, s'_1[$ and $u < 0$ on $]s'_2, s'_2 + \varepsilon[$. Note then that $\rho(s, t) = \rho(s)(t) \in W^u(b) \subset T_b$ for $s \in I''$ and $t \in [\tau, f(b)]$, since $W^u(b)$ is flow invariant. Now fix $\tau' = f(b) + \varepsilon$ for some $\varepsilon > 0$ such that $\rho(s, t) \in T_b$ for $t \in J' = [\tau, \tau']$, $s \in I''$ and write $\rho(s, t) = (x(s, t), u(s, t))$ for $t \in J'$ and $s \in I''$. Then clearly $u = 0$ on $I'' \times [\tau, f(b)]$ and u is either strictly positive or strictly negative on $I'' \times]f(b), \tau']$, say strictly positive.⁴ Since ρ is continuous $d_\infty(\rho(s'), \rho(s)) < \varepsilon$ for any $\varepsilon > 0$ and s close to s' , hence $\rho(s, t) \in T_b$ for $t \in J'$ and s close to $s' \in I''$. In particular this implies that for fixed $t' \in]f(b), \tau']$ the normal coordinate $u(s', t)$ is strictly positive for all s close to s'_2 . But by our assumption $u(s, \tau) = u(s) < 0$ for all s close to s'_2 with $s > s'_2$, hence $u(s', t) < 0$ for all s close to s'_2 with $s > s'_2$, since flow lines $t \mapsto \rho(s)(t)$ do not cross $W^u(b)$. This is a contradiction and so we conclude that; p can not cross $W^u(b)$. The above argument also shows that: If $u(s) = 0$ for some $s \in I'$ and $u(s, t) > 0$ (resp. $u(s, t) < 0$) for $t \in]f(b), \tau']$ then $u \geq 0$ (resp. $u \leq 0$) on I' . And if $u \neq 0$ on I' then either $u > 0$ or $u < 0$ on I' . Finally note that the above applies equally well in the case where $W^u(b)$ is replaced by $W^s(a)$ with $\lambda_a = 1$.

4.9 Lemma.

Let $f : M \rightarrow \mathbb{R}$ be a self indexing Morse-Smale function with only one minimum q and one maximum p , and let $B^1 \subset \overline{M}(q, p)$ denote the subspace of all flow lines $\beta \in \overline{M}(q, p)$ for which $\mathbf{b}(\beta) = \{q, c, p\}$ and λ_c is either $n - 1$ or 1 . Then the inclusion $M(q, p) \hookrightarrow (M(q, p) \cup B^1)$ induces an injection on π_0 . Moreover, the inclusion induces a bijection if the Riemannian metric is compatible with the Morse charts.

The assumption on λ_c may be removed if one adds the condition that the Riemannian metric is compatible with the Morse charts, see lemma 4.11.

⁴In the case strictly negative the following argument has to be applied to a neighborhood of s'_1 instead of s'_2 .

Proof:

The idea of the proof is as follows. Assume that $\mathbf{b}(\rho(s)) \subset \text{Crit}_{n-1}(f) \cup \{p, q\}$ for any $s \in I$. We will show that it is possible to perturb the level τ -map ($\tau \in]0, 1[$) to a continuous map whose trajectory is contained in $M(q, p)$. The (right) perturbation relies on the following observation concerning T_b .

For each $x \in W^u(b)$ there exists an open neighborhood U_x in M of x such that $U_x \cap (\cup_{b' \neq b} W^u(b')) = \emptyset$, since $W^u(b) \not\subset \cup_{b' \neq b} \partial W^u(b')$. Moreover the subspace $\overline{\cup_b W^u(b) \cup W^u(p)} \subset M$ is open since it is the complement of the closed set $\overline{\cup_{c: \lambda_c < n-1} W^u(c)} = \cup_{c: \lambda_c < n-1} \overline{W^u(c)}$. We choose each U_x such that $U_x \subset W^u(b) \cup W^u(p)$, and if necessary we shrink T_b such that $T_b \subseteq \cup_x U_x$. Hence $T_b \cap T_{b'} = \emptyset$ iff $b \neq b'$ and $m \in T_b$ implies that $m \in W^u(b) \cup W^u(p)$.

Let $T = \cup_b T_b$, fix $\tau \in]0, 1[$, let $p = p_\tau$ and note that $M^\tau = W^s(q)^\tau$ since f is self indexing with one minimum q . Now $O = \{s \in I \mid p(s) \in T\}$ is open hence $O = \cup I_i$ where each I_i is an open connected interval. We assume that each I_i is maximal wrt. p and write $p(s) = (x(s), u(s))$ on each I_i .

Let $C = \{s \in I \mid p(s) \in \cup_b W^u(b)\}$ which is closed (therefore compact), since $\mathbf{b}(\rho(s)) \subset \text{Crit}_{n-1}(f) \cup \{p, q\}$ for any $s \in I$. Hence we may assume that O is a finite union since it covers C .

Fix some $I_i =]s_1, s_2[$ and let $I' = I_i \cap C$ (which is closed but not necessarily connected) i.e. $u|_{I'} = 0$. From the above we then have that the normal coordinate u of p is either > 0 or < 0 in a neighborhood of both s_1 and s_2 , say > 0 . Let s'_1 and s'_2 denote the endpoints ($s'_1 \leq s'_2$) of I' and choose $\varepsilon > 0$ small. Let $s^1 < s'_1$ and $s^2 > s'_2$ be such that $u(s^i) = \varepsilon$ for $i = 1, 2$ and replace the curve segment $p([s^1, s^2])$ by (the image of) the curve $c : [s^1, s^2] \rightarrow T$, $s \mapsto (x(s), \varepsilon)$.

To be more precise regarding the choices of ε : For each $s \in I'$ there exists an $\varepsilon_s > 0$ such that $B_{\varepsilon_s}((x(s), 0)) \subset T \cap W^s(q)$. Now the union of such balls is an open cover of the compact subspace $(x(I'), 0)$, hence letting $\varepsilon = \min_s \{\varepsilon_s\}$ we conclude that $\varepsilon > 0$ and $\text{im}(c) \subset T$. Note that by construction of T_b (hence of T) we have in fact that $\text{im}(c) \subset W^u(p) \cap W^s(q)$.

We now proceed as above for each I_i . So in conclusion we have constructed a continuous curve $p' : I \rightarrow M$ from $\eta(\tau)$ to $\eta'(\tau)$ which avoids $\cup_{c \neq p} W^u(c)$ i.e. $\text{im}(p') \subset W(p, q)$. Hence if we define $\rho' : I \rightarrow M(q, p)$; $t \mapsto \eta_{p'(t)}$ then $\rho' \in C((I, 0, 1), (M(q, p), \eta, \eta'))$ so η and η' are in the same path component of $\overline{M}(q, p)$. This proves the first part of the lemma, and the second part follows from corollary 4.7. \square

As a consequence of the above lemma we have the following result which will be used in chapter 5.

4.10 Proposition.

Let $\dim(M) = 3$, and $f : M \rightarrow \mathbb{R}$ be a self indexing Morse-Smale function with only one minimum q and one maximum p . Then the inclusion $M(q, p) \hookrightarrow \overline{M}(q, p)$ induces an injection on π_0 . Moreover, the inclusion induces a bijection if the Riemannian metric is compatible with the Morse charts, so $\#\overline{M}(q, p) = \#M(q, p)$.

The second half of the above proposition is an immediate consequence of lemma 4.14 in section 4.4.

Proof:

Let $\tau \in]1, 2[$, and $p(s) = \rho(s)(\tau)$. The idea of the proof is to perturb p such that it induces a continuous curve with values in $M(q, p) \cup B^1$, where B^1 is as in lemma 4.9.

First we make the follow observation. If $\rho(s) = \rho(s') = \beta$ for $s < s'$ then we redefine ρ on $[s, s']$ to be the constant map $s \mapsto \beta$. Applying this construction for every intersection we obtain a loop free path, and by corollary 3.11 in [RF06] we may reparameterize to obtain an embedding of I in $\overline{M}(q, p)$. It is then clear that we may assume wlog. that ρ is injective.

Now let s' be such that $\mathbf{b}(\rho(s')) = \{q, a, b, p\}$, with $\lambda_a = 1$ and $\lambda_b = 2$. Then $p(s') \in W(b, a)^\tau$ and by transversality (see ([Kos93],p.62)) there is a chart $U \subset M^\tau$ around $p(s')$ such that $U \approx \mathbb{R} \times \mathbb{R}$ with $U \cap W^u(a)^\tau \approx \mathbb{R} \times \{0\}$ and $U \cap W^s(a)^\tau \approx \{0\} \times \mathbb{R}$. Note that we may choose U such that the only (un)stable manifolds (besides $W(p, q)$ of course) which intersects U non trivially is $W^u(b)$ and $W^s(a)$.

By the above there exists an interval I' around s' such that $p(s) = (u(s), v(s))$ is in only one of the four quadrants, say the second quadrant i.e. $u(s) \leq 0$ and $v(s) \geq 0$ (see figure 4.4 below). Note that $0 = (u(s), v(s))$ only at s' since ρ is injective (in fact s' is the only parameter with the above properties). Choose $s_1 < s' < s_2$ and let $x_1 = p(s_1)$ and $x_2 = p(s_2)$. Now redefine p as follows; let $l : [s_1, s_2] \rightarrow M^\tau$ be the linear map from x_1 to x_2 i.e. $s \mapsto x_2(s_1 - s)/(s_1 - s_2) + x_1(s - s_2)/(s_1 - s_2)$, and redefine p as $p = l$ on $[s_1, s_2]$ and otherwise unchanged.

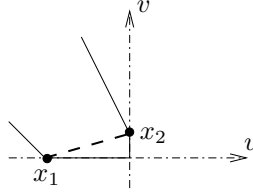

Figure 4.4: The image of $s \mapsto p(s)$ in U near a point in the transverse intersection $W^u(b) \pitchfork W^s(a) \pitchfork f^{-1}(\tau)$.

It is clear that p is continuous and we claim that p induces a curve in $\overline{M}(q, p)$. This is clearly true if $x_1, x_2 \in W(p, q)$, hence assume that $x_1 \in W^u(b)$, say (otherwise $x_1 \in W^s(a)$ by the choice of U). Now $\rho(s_1) = \beta \# \beta_+$ where $\beta \in M(q, b)$ with $\beta(\tau) = x_1$, and β_+ is one of the two elements of $M(b, p) = \{\beta_+, \beta_-\}$. Note that β_+ is determined uniquely by which side of $W^u(b)$ the point x_2 is on. We show $\lim_{s \rightarrow s_1} \eta_{p(s)} = \rho(s_1)$ in $\overline{M}(q, p)$. It is obvious that the limit exists (call it β') and that $\beta' = \beta \# \beta_{\pm}$, where β_{\pm} denotes either β_+ or β_- . But $\eta_{p(s)}(\tau)$ and x_2 are on the same side of $W^u(b)$, hence by the above $\beta_{\pm} = \beta_+$. If necessary we apply similar arguments at x_2 to obtain a curve $\rho' : I \rightarrow \overline{M}(q, p)$ defined by $\rho'(s) = \eta_{p(s)}$ on $[s_1, s_2]$ and $\rho' = \rho$ otherwise.

Note that there are at most $4 \sum_{(b,a)} \#M(b, a)$ such s' , hence we proceed as above for each such parameter to obtain a curve, also denoted ρ' . Now $l(\mathbf{b}(\rho'(s))) \leq 2$ by construction hence we may apply (the proof of) lemma 4.3 to conclude that $C((I, 0, 1), (M(q, p), \eta, \eta')) \neq \emptyset$. So the inclusion $M(q, p) \hookrightarrow \overline{M}(q, p)$ induces an injection on π_0 , and by corollary 4.7 it is a bijection if the Riemannian metric is compatible with the Morse charts. \square

We now return to the general case of injectivity, and show that the assumption from lemma 4.9 on the index may be removed, if the Riemannian metric is compatible with the Morse charts.

As above let $\rho \in C((I, 0, 1), (\overline{M}(q, p), \eta, \eta'))$ and assume that $\# \mathbf{b}(\rho(s)) \leq 2$. Now fix $c \in \text{Crit}(f) - \{q, p\}$ for which $c \in \mathbf{b}(\rho(s))$ for some $s \in I$. Let $U_c \subset M$ be a Morse chart at c and choose τ, κ such that $W^u(c)^\kappa \cap U_c$ and $W^s(c)^\tau \cap U_c$ both are non empty. The set $I_c = \{s \in I \mid \rho(s)(\kappa) \in W^u(c)\}$ is clearly closed (hence compact) and $O_c = \{s \in I \mid \rho(s)(\kappa) \in U_c\}$ is an open cover of I_c , so we may assume that $O_c = \cup I_i$ for some finite union of open connected intervals.

In the sequel we make a purely local construction, hence we identify U_c with $\mathbb{E} = \mathbb{E}^u \oplus \mathbb{E}^s$. Moreover, we let $c = 0$, $f(0) = 0$, $\tau = 1$ and $\kappa = -1$. As in the construction of the gluing map we have the level surfaces \mathbb{E}^τ and \mathbb{E}^κ , on which

we use the following coordinates

$$\begin{aligned} \psi_\tau : \mathbb{E}^u \times \mathbb{S}^s &\xrightarrow{\approx} \mathbb{E}^\tau \\ (x, v) &\mapsto (x, v\sqrt{1+|x|^2}), \quad \psi_\tau^{-1} : (x, y) \mapsto (x, \frac{y}{\sqrt{1+|x|^2}}) = (x, \frac{y}{|y|}) \end{aligned}$$

and

$$\begin{aligned} \psi_\kappa : \mathbb{S}^u \times \mathbb{E}^s &\xrightarrow{\approx} \mathbb{E}^\kappa \\ (u, y) &\mapsto (u\sqrt{1+|y|^2}, y), \quad \psi_\kappa^{-1} : (x, y) \mapsto (\frac{x}{\sqrt{1+|y|^2}}, y) = (\frac{x}{|x|}, y) \end{aligned}$$

It follows that the "flow map" F (defined by (4.2)) in these coordinates is $\mathbb{E}^\tau - \mathbb{S}^s \xrightarrow{\approx} \mathbb{E}^\kappa - \mathbb{S}^u$; $(x, v) \mapsto (x/|x|, |x|v)$, or in polar coordinates $F : (ru, v) \mapsto (u, rv)$. Note that we need to assume here that the Riemannian metric is compatible with the Morse charts.

Now fix some $I' = I_i$ from above and write $\rho(s)(\tau) = (x(s), v(s))$ and $\rho(s)(\kappa) = (u(s), y(s))$ on I' . Note that $I_c = \{s \in I \mid \rho(s)(\tau) \in W^s(c)\}$, hence $x(s) = 0 = y(s)$ only on the closed set $I'_c = I' \cap I_c$. So on $I' - I'_c$ we may use polar coordinates $x(s) = r_\tau(s)u_\tau(s)$ and $y(s) = r_\kappa(s)v_\kappa(s)$. But $(u(s), r_\kappa(s)v_\kappa(s)) = (u(s), y(s)) = F(x(s), v(s)) = F(r_\tau(s)u_\tau(s), v(s)) = (u_\tau(s), r_\tau(s)v(s))$, hence $u(s) = u_\tau(s)$, $v(s) = v_\kappa(s)$ and $r_\tau(s) = r_\kappa(s)$ on $I' - I'_c$. It follows that we may write $\rho(s)(\tau) = (r(s)u(s), v(s))$ and $\rho(s)(\kappa) = (u(s), r(s)v(s))$ on I' , where r is defined as $r_\tau = r_\kappa$ on $I' - I'_c$ and $r = 0$ on I'_c . It is then clear that r is continuous.

Let $I'' = [s_1, s_2]$ be such that $I'_c \subset I'' \subset I'$, and note that $\rho(I'')(\kappa) \subset W^s(q)$ in particular.⁵ Since $W^s(q)$ is open (in M and therefore also in \mathbb{E}) we have that for each $s \in I''$ there exists a $\delta_s > 0$ such that $B_{\delta_s}(\rho(s)(\kappa)) \subset W^s(q)$. In particular, $\cup_{s \in I''} B_{\delta_s}(\rho(s)(\kappa))$ is an open cover of the compact set $\rho(I'')(\kappa)$ and so $\delta^\kappa = \inf_s \{\delta_s\} > 0$. Now apply similar arguments in the case $\rho(I'')(\tau) \subset W^u(p)$ to obtain a $\delta^\tau > 0$ and set $\delta = \min\{\delta^\kappa, \delta^\tau\}$.

Let $p : I'' \rightarrow \mathbb{E}^\tau$ be the (continuous) curve defined by $p(s) = (\max\{\delta/2, r(s)\}u(s), v(s))$. Note that we may assume that $p(s_i) = \rho(s_i)(\tau)$ ($i = 1, 2$) by choosing δ smaller if necessary. By construction we then have $|p(s) - \rho(s)(\tau)| \leq \delta/2$ and $|F(p(s)) - \rho(s)(\kappa)| \leq \delta/2$, hence $p(s) \in W(p, q)$ for all $s \in I''$. We can now redefine ρ as the (continuous) curve $I \rightarrow \overline{M}(q, p)$ which is ρ on $I - I''$ and $\eta_{\psi \circ p}$ on I'' , where ψ is the Morse chart $\mathbb{E} \xrightarrow{\approx} U_c$.

⁵ $\rho(I)(\kappa) \subset W^s(q)$ by assumption.

As above we proceed for each I_i , and then repeat for each $c \in \cup_s \mathbf{b}(\rho(s))$. In the end this construction yields an element of $C((I, 0, 1), (M(q, p), \eta, \eta'))$. Hence we have proven.

4.11 Lemma.

Let $f : M \rightarrow \mathbb{R}$ be a self indexing Morse function on a Riemannian manifold (M, \mathbf{g}) such that (f, \mathbf{g}) is Morse-Smale and \mathbf{g} is compatible with the Morse charts. Assume that f only has one minimum q and one maximum p , and let $B^1 \subset \overline{M}(q, p)$ denote the subspace of all flow lines $\beta \in \overline{M}(q, p)$ for which $\mathbf{b}(\beta) = \{q, c, p\}$. Then the inclusion $M(q, p) \hookrightarrow (M(q, p) \cup B^1)$ induces a bijection on π_0 . In particular, $\#\pi_0(M(q, p)) = \#\pi_0(M(q, p) \cup B^1)$ i.e. the number of path components $\#\pi_0(M(q, p))$ remains constant if we add to $M(q, p)$ the subspace B^1 .

4.4 Extending injectivity

In this section we show (see lemma 4.14) an extension of the result of lemma 4.11. Notation will be as above. We assume throughout that (as above) f is a self indexing Morse-Smale function with only one minimum/maximum, and that the Riemannian metric is compatible with the Morse charts.

To produce the generalization of lemma 4.11 we need the following technical lemma. This should be seen as a generalization of the technique used to prove the injectivity result in the three dimensional case (proposition 4.10).

4.12 Lemma.

Let $b \in \text{Crit}_{n-2}f$ and choose $\delta > 0$ small such that $\kappa = f(b) - \delta$ is a regular value. Moreover, let k denote the (finite) number of flow lines from a to b where a runs over all critical points of index $n - 1$, i.e. $k = \sum_{a \in \text{Crit}f: \lambda_a = n-1} \#M(a, b)$. There exists a two dimensional ε -disk bundle $W^u(b)^\kappa \times B_\varepsilon(0)$ over $W^u(b)^\kappa$ in $f^{-1}(\kappa)$ such that each fiber $\{u\} \times B_\varepsilon(0)$ is separated into k sections by (the image of) k smooth curves which all depend smoothly on the base point. Moreover, the curves are all of the form

$$[0, \varepsilon[\times W^u(b)^\kappa \rightarrow W^u(b)^\kappa \times B_\varepsilon(0); (t, u) \mapsto (u, tv(t, u)) \quad |v(t, u)| = 1$$

with $(u, tv(t, u)) \in W^u(a)^\kappa$ for all $t \neq 0$ when $W^u(b)^\kappa \times B_\varepsilon(0)$ is identified with an open neighborhood of $W^u(b)^\kappa$ in $f^{-1}(\kappa)$.

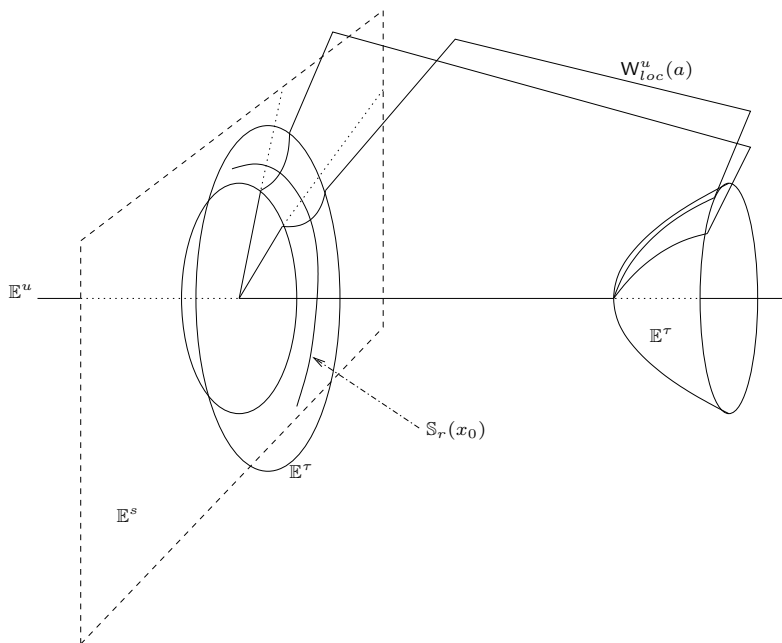

Figure 4.5: A graphic interpretation of the construction in the proof of lemma 4.12, with $k = 2$. Note that $\mathbb{S}_r(x_0)$ is only partially illustrated.

Proof:

We recommend consulting figure 4.5 for a graphic interpretation of the following construction.

The proof consists of a local construction, so let (ψ, U) be a Morse chart around b . We identify U with $\mathbb{E} = \mathbb{E}^u \oplus \mathbb{E}^s$ having coordinates (x, y) , hence $(x, y) = (x_1, \dots, x_{n-2}, y_1, y_2)$ and we sometimes write $x \in \mathbb{E}^u$ instead of $(x, 0)$ (similarly for $y \in \mathbb{E}^s$). By abuse of notation we write f and φ for the local representatives $f \circ \psi^{-1}$ and $\psi \circ \varphi_t \circ \psi^{-1}$ respectively. Moreover we let $\psi(q) = 0$ and $f(0) = 0$ hence $f(x, y) = -|x|^2 + |y|^2$ by the Morse lemma, and $\varphi_t(x, y) = (xe^{2t}, ye^{-2t})$ since g is compatible with U .

For the moment let us assume that $\text{Crit}_{n-1}(f) = \{a\}$. Let $W^u_{loc}(a)$ denote the local representatives of $W^u(a)$, i.e. $W^u_{loc}(a) \approx U \cap W^u(a)$ (\mathbb{E}^u and \mathbb{E}^s are the local representatives of $W^u(b)$ and $W^s(b)$ respectively). If necessary we change coordinates such that $\kappa = -1$, and let $\tau = 1$. We may (and will) assume that both κ and τ are regular values. Finally let $\mathbb{E}^\tau = f^{-1}(\tau)$ and $\mathbb{E}^\kappa = f^{-1}(\kappa)$.

Now $W(a, b) = W^u(a) \pitchfork W^s(b)$ consists of finitely many orbits since $\mu(a, b) = 1$. Hence $W_{loc}^u(a) \pitchfork \mathbb{S}^s$, where $\mathbb{S}^s = \mathbb{E}^s \pitchfork \mathbb{E}^\tau$ denotes the unit sphere in \mathbb{E}^s , consists of finitely many points, say $\{y_1, \dots, y_k\} \subset \mathbb{E}^s$ (or equivalently $\{(0, y_1), \dots, (0, y_k)\} \subset \mathbb{E}$).

Let $\mathbb{E}_{x_0} \subset \mathbb{E}$ denote the affine linear subspace at $x_0 \in \mathbb{E}^u$ parallel to \mathbb{E}^s i.e. $\mathbb{E}_{x_0} = \{(x, y) \in \mathbb{E} \mid x = x_0\}$. Note that $\mathbb{E}_0 = \mathbb{E}^s$. Since transversality is an open condition it follows that $\mathbb{E}_{x_0} \pitchfork \mathbb{E}^\tau$ and $W_{loc}^u(a) \pitchfork (\mathbb{E}_{x_0} \pitchfork \mathbb{E}^\tau)$, for $|x_0|$ small. Let $\mathbb{S}_r(x_0) \subset \mathbb{E}_{x_0}$ denote the sphere centered at $(x_0, 0)$ of radius $r^2 = |x_0|^2 + 1$, then $\mathbb{S}_r(x_0) = \mathbb{E}_{x_0} \pitchfork \mathbb{E}^\tau$ and $W_{loc}^u(a) \pitchfork \mathbb{S}_r(x_0)$ consists of finitely many points $\{(x_0, y_1(x_0)), \dots, (x_0, y_k(x_0))\}$ with $(0, y_i(0)) = (0, y_i)$. The notation $y_i(x_0)$ is simply to indicate that the point depends on x_0 . As we shall see now this dependence is smooth.

Let $\varepsilon > 0$ be small, by varying x_0 in the open ε -ball $B_\varepsilon^u(0) \subset \mathbb{E}^u$ we obtain k functions

$$B_\varepsilon^u(0) \rightarrow B_\varepsilon^u(0) \times \mathbb{E}^s; x \mapsto (x, y_i(x)) \quad (4.3)$$

by specifying the image of x by the i 'th map as the i 'th element in

$$W_{loc}^u(a) \pitchfork \mathbb{S}_{\sqrt{|x|^2+1}}(x) = \{(x, y_1(x)), \dots, (x, y_k(x))\}$$

Assertion: For each i the function y_i of (4.3) is smooth, and $(x, y_i(x)) \in W_{loc}^u(a) \pitchfork \mathbb{E}^\tau$ for all $x \in B_\varepsilon^u(0)$.

Proof: The last part of the assertion is clear by construction. Smoothness will be a consequence of transversality and the implicit function theorem. Write $W_{loc}^u(a)^\tau = W_{loc}^u(a) \pitchfork \mathbb{E}^\tau$ and identify \mathbb{E}^τ with $\mathbb{E}^u \times \mathbb{S}^s$ using the coordinate transformation ψ_τ^{-1} on page 63. By abuse of notation we write $W_{loc}^u(a)^\tau$ for $\psi_\tau^{-1}(W_{loc}^u(a)^\tau)$. Let (x, v) denote the coordinates in $\mathbb{E}^u \times \mathbb{S}^s$ with $(0, v_i)$ representing $(0, y_i)$, hence $(0, v_i) \in W_{loc}^u(a)^\tau \pitchfork \mathbb{S}^s$.

Now around each $(0, v_i)$ there exists, by transversality,⁶ a chart $U_i \xrightarrow{\theta} \mathbb{R}^{n-2} \times \mathbb{R}$; $(x, v) \mapsto (\nu, \sigma)$, $U_i \subseteq \mathbb{E}^u \times \mathbb{S}^s$, in which $W_{loc}^u(a)^\tau \cap U_i$ is represented by coordinates of the form $(\nu, 0)$ and $(\{0\} \times \mathbb{S}^s) \cap U_i$ is represented by coordinates of the form $(0, \sigma)$, i.e. we have the following commutative diagram

$$\begin{array}{ccccc} (\{0\} \times \mathbb{S}^s) \cap U_i & \hookrightarrow & U_i & \longleftarrow & W_{loc}^u(a)^\tau \cap U_i \\ \downarrow \theta & & \downarrow \theta & & \downarrow \theta \\ \{0\} \times \mathbb{R} & \longleftarrow & \mathbb{R}^{n-2} \times \mathbb{R} & \longrightarrow & \mathbb{R}^{n-2} \times \{0\} \end{array}$$

⁶See e.g. ([Kos93],p.62) or ([Bre93],p.84)

Let $\theta_{n-1} : U_i \rightarrow \mathbb{R}$ denote the $(n-1)$ 'th coordinate function of θ . Then $\theta_{n-1}(0, v_i) = 0$ since $(0, v_i) \in W_{loc}^u(a)^\tau \pitchfork \mathbb{S}^s$, and $D_2\theta_{n-1}(0, v_i) \neq 0$ by the (left) diagram. Hence may apply the implicit function theorem to obtain a smooth map $v_i(x) = v$ defined for $|x|$ small, such that $\theta_{n-1}(x, v_i(x)) = 0$ (hence $(x, v_i(x)) \in W_{loc}^u(a) \pitchfork \mathbb{E}^\tau$ by the (right) diagram). This completes the proof of the assertion.

It is clear that $W(a, b)$ locally separates $\mathbb{E}^s - \{0\}$ into k cone like sections. We will transfer this structure to a level below b .

We transport each of the k orbits corresponding to $x \mapsto (x, y_i(x))$ to the level surface \mathbb{E}^κ as follows. Let us use polar coordinates to denote points in $\mathbb{E} - \{0\}$ i.e. (tu, sv) where $u \in \mathbb{S}^u$ and $v \in \mathbb{S}^s$ are unit vectors in \mathbb{E}^u and \mathbb{E}^s respectively, and $t, s \in]0, \infty[$. The maps of (4.3) can then be written as

$$[0, \varepsilon[\times \mathbb{S}^u \rightarrow \mathbb{B}_\varepsilon^u(0) \times \mathbb{E}^s; (t, u) \mapsto (tu, sv_i(tu)), \quad (tu, sv_i(tu)) \in W_{loc}^u(a) \pitchfork \mathbb{E}^\tau$$

since $1 = -t^2 + s^2$, hence $s = s(t) = \sqrt{1+t^2}$. Note that we have included 0 in the domain since $(tu, s(t)v_i(tu)) \rightarrow (0, v_i(0))$ for $t \rightarrow 0$. Now using the "flow map" defined by (4.2) we obtain, for each i , a map

$$[0, \varepsilon[\times \mathbb{S}^u \rightarrow W_{loc}^u(a) \pitchfork \mathbb{E}^\kappa; (t, u) \mapsto (s(t)u, tv_i(tu)) \quad (4.4)$$

In particular, for fixed u we obtain k curves

$$[0, \varepsilon[\rightarrow W_{loc}^u(a) \pitchfork \mathbb{E}^\kappa; t \mapsto (s(t)u, tv_i(tu))$$

Now using the coordinate transformation ψ_κ^{-1} on page 63 we identify \mathbb{E}^κ with $\mathbb{S}^u \times \mathbb{E}^s$. Note that \mathbb{S}^u is fixed under this transformation. Moreover we consider $\mathbb{S}^u \times \mathbb{B}_\varepsilon^s(0) \subset \mathbb{S}^u \times \mathbb{E}^s$ as a two dimensional ε -disk bundle over \mathbb{S}^u . Since $\mathbb{S}^u = \mathbb{E}^u \pitchfork \mathbb{E}^\kappa \approx W^u(b)^\kappa$, this gives the disk bundle of the lemma (with $\mathbb{B}_\varepsilon(0) = \mathbb{B}_\varepsilon^s(0)$). Moreover, the maps of (4.4) are transformed to

$$\begin{aligned} [0, \varepsilon[\times \mathbb{S}^u \rightarrow \mathbb{S}^u \times \mathbb{B}_\varepsilon^s(0); (t, u) \mapsto (u, tv_i(tu)) \\ (u, tv_i(tu)) \in \psi_\kappa^{-1}(W_{loc}^u(a) \pitchfork \mathbb{E}^\kappa), \quad t > 0 \end{aligned}$$

Hence to each point $u \in \mathbb{S}^u$ in the base space there corresponds k smooth curves in the fiber $\{u\} \times \mathbb{B}_\varepsilon^s(0)$. These depend smoothly on u , and their images separate each fiber into k cone like sections. Finally, let $\text{Crit}_{n-1}(f) = \{a_1, \dots, a_l\}$. Since all the unstable manifold corresponding to the a_i 's are disjoint it follows that we may generalize the above to all $k = \sum k_i$ curves. This completes the proof. \square

Note that with some obvious changes the lemma applies in the case of index one and two, i.e. $\lambda_b = 2$ and $\lambda_a = 1$. Moreover it follows (by the last part of the lemma and since f is self indexing) that each point in the interior of a section belongs to $W^u(p)^\kappa$.

Now since the curves depend smoothly on the base point, the sections of each fiber vary smoothly, hence the disk bundle is separated into k cone sections bounded on each side by (the image) of one of the maps $(t, u) \mapsto (u, tv_i(ut))$, see figure 4.6. More precisely, choose an orientation of $W^s(b)^\tau \approx \mathbb{S}^s$ and index the k points $\cup_a W(a, b)^\tau$ according to this orientation, where one of the points is chosen as the start point. We then define a cone section of $W^u(b)^\kappa \times \mathbb{B}_\varepsilon(0)$ to be the subset of $W^u(b)^\kappa \times \mathbb{B}_\varepsilon(0)$, bounded by the images of the i 'th and $(i + 1)$ 'th maps (if $i = k$ then $i + 1 = 1$). The maps $(t, u) \mapsto (u, tv_i(ut))$ will henceforth be called boundary maps.

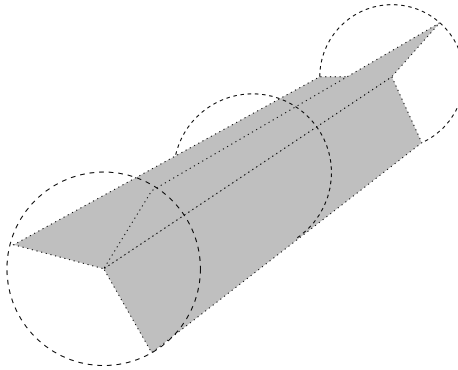

Figure 4.6: A (simplified) part of $W^u(b)^\kappa \times \mathbb{B}_\varepsilon(0)$, with $k = 3$.

Let ρ be as in the last section. We assume throughout that $l(\mathbf{b}(\rho(s))) \leq 4$ and if $c \in \mathbf{b}(\rho(s)) - \{q, p\}$ then λ_c is either $n - 1$ or $n - 2$. Moreover, we identify the disk bundle from the lemma with an open neighborhood of $W^u(b)^\kappa$ in $f^{-1}(\kappa)$. Now let $S \subset I$ be a maximal (open) connected interval such that the level curve $p(s) = \rho(s)(\kappa)$ is contained in the disk bundle $W^u(b)^\kappa \times \mathbb{B}_\varepsilon(0)$.

With the above conventions we have (note the resemblance with the fact that a level curve can not cross $W^u(a)$, see the beginning of section 4.3 for details).

4.13 Claim.

For all $s \in S$ and some $i \in \{1, \dots, k\}$, the image of the level curve $s \mapsto p(s)$ is contained in the subset of $W^u(b)^\kappa \times B_\varepsilon(0)$ bounded by the images of the i 'th and $(i+1)$ 'th boundary maps.

Proof:

In the following we will use notation and terminology as in the proof of lemma 4.12. Let $\text{Crit}_{n-1}(f) = \{a_1, \dots, a_i\}$, $\cup_i W(a_i, b)^\tau = \{m_1, \dots, m_k\}$, I_j denote the (closed) segment on the circle $W^s(b)^\tau \approx \mathbb{S}^1$ from m_j to m_{j+1} (with $k+1=1$), B_j the image of the j 'th cone map, and C_j the cone section bounded by B_j and B_{j+1} .

Assume that the claim is false. Since each point in the boundary of a cone section belongs to either an unstable manifold corresponding to critical points of index $n-1$ or the zero section of $W^u(b)^\kappa \times B_\varepsilon(0)$, we conclude, by the beginning of section 4.3, that $s \mapsto p(s)$ must cross the zero section when going from one cone section (say C_j) to another (say $C_{j'}$, $j' \neq j$).

Let $S' \subset S$ be a maximal (closed) connected interval such that $p(s) = (u(s), 0)$ on S' , and N an open neighborhood of S' with $S' \subset N \subset S$. We let L and R denote the open intervals corresponding to the left and right part of $N - S'$. Note that $\rho(s)(\tau)$ is contained in precisely one I_i for $s \in S'$.

1) Assume that $p(s) \in B_j$ for $s \in L$ and $p(s) \in B_{j'}$ for $s \in R$. Note that $j' \neq j \pm 1, j$. The first assumption implies that $\rho(s)(\tau)$ is contained in either I_j or I_{j-1} for $s \in S'$, whereas the second assumption implies that $\rho(s)(\tau)$ is contained in either $I_{j'}$ or $I_{j'-1}$ for $s \in S'$. This is a contradiction since neither of these intervals agree.

2) Assume that $p(s)$ is in the interior of C_j (resp. $C_{j'}$) for $s \in L$ (resp. $s \in R$). The first assumption implies that $\rho(s)(\tau)$ is contained in I_j for $s \in S'$, and the second that $\rho(s)(\tau)$ is contained in $I_{j'}$ for $s \in S'$. Again this is a contradiction since $I_j \neq I_{j'}$.

3) Assume that $p(s) \in B_j$ for $s \in L$ and $p(s)$ is in the interior of $C_{j'}$ for $s \in R$. Note that $j' \neq j-1, j$. The first assumption implies that $\rho(s)(\tau)$ is contained in either I_j or I_{j-1} for $s \in S'$, whereas the second implies that $\rho(s)(\tau)$ is contained in $I_{j'}$ for $s \in S'$. As above this is a contradiction. Note that the symmetric version of this case also yields a contradiction.

This completes the proof, since the behavior of the level curve is described by one of the above cases. \square

In the case of the claim we say that the level curve $s \mapsto p(s)$ is contained in one

cone section for all $s \in S$. Strictly speaking this convention is ambiguous since a boundary is shared by two (neighboring) cone sections.

The idea is now to use the above results and, for each b , to look at the behavior of $p(s)$ as it enters and leaves the disk bundle and then perturb it to a map with chain length two or three. Lemma 4.11 will then imply the desired result above. Note the resemblance with the proof strategy of lemma 4.11.

Before we begin the proof of the main lemma of this chapter we present the following figures, illustrating some possible behaviors of ρ on S (or sub intervals of S).

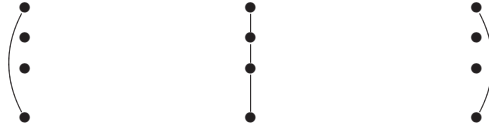

Figure 4.7: The progress of ρ on $J \subseteq S$, where \bullet denote the critical points q , b , a and p listed from below. Hence $p(s) = \rho(s)(\kappa)$ enters and leaves the zero section of the disk bundle through the interior of a section.

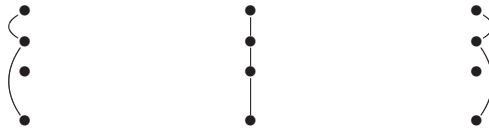

Figure 4.8: The progress of ρ on $J \subseteq S$, where \bullet denote the critical points q , b , a and p listed from below. Hence $p(s) = \rho(s)(\kappa)$ enters and leaves the zero section of the disk bundle through the boundary of a section.

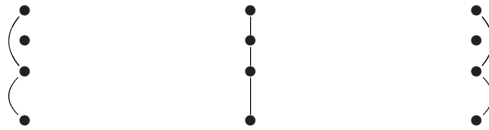

Figure 4.9: The progress of ρ on $J \subset S$, where \bullet denote the critical points q , b , a and p listed from below. Hence $\rho(s)(\kappa)$ is in the zero section of the disk bundle for all $s \in J$.

4.14 Lemma.

Let $f : M \rightarrow \mathbb{R}$ be a self indexing Morse function on a Riemannian manifold (M, \mathbf{g}) such that (f, \mathbf{g}) is Morse-Smale and \mathbf{g} is compatible with the Morse charts. Let B^1 be as in lemma 4.11. Assume that f only has one minimum q and one maximum p , and let $B^2 \subset \overline{M}(q, p)$ denote the subspace of all flow lines $\beta \in \overline{M}(q, p)$ for which $\mathbf{b}(\beta) = \{q, b, a, p\}$ with either $\lambda_b = n - 2$ and $\lambda_a = n - 1$, or $\lambda_b = 2$ and $\lambda_a = 1$. Then the inclusion $M(q, p) \hookrightarrow (M(q, p) \cup B^1 \cup B^2)$ induces a bijection on π_0 . In particular, $\#\pi_0(M(q, p)) = \#\pi_0(M(q, p) \cup B^1 \cup B^2)$ i.e. the number of path components $\#\pi_0(M(q, p))$ remains constant if we add to $M(q, p)$ the subspaces B^1 and B^2 .

Proof:

We proceed by using notation and terminology as in the proof of lemma 4.12 and claim 4.13. Moreover, since the strategy of this proof resembles that of lemma 4.9, we leave some technical details to the reader.

Let $\rho \in C((I, 0, 1), (\overline{M}(q, p), \eta, \eta'))$, with $I = [0, 1]$ and $\eta, \eta' \in M(q, p)$, such that $\rho(s) \in B^1 \cup B^2 \cup M(q, p)$ for all $s \in I$.

For $s' \in I$ with $\mathbf{b}(\rho(s')) = \{q, b, a, p\}$, $\lambda_b = n - 2$, $\lambda_a = n - 1$, let $S =]s_1, s_2[$ be a maximal sub-interval of I such that $p(s) = \rho(s)(\kappa)$ is in the ε -disk bundle of lemma 4.11, and such that $s' \in S$, i.e. $p(s)$ belongs to the zero section for at least one point in S . Moreover, we choose ε such that $\mathbf{b}(\rho(s)) \cap (\text{Crit}_2(f) \cup \text{Crit}_1(f)) = \emptyset$ for all $s \in S$, hence $p(s) \in W^s(q)^\kappa$ for all $s \in S$.

Now for each $s \in S$ choose an open neighborhood $U_{p(s)} \subset W^s(q)^\kappa$ in M^κ of $p(s)$, and let $U = \cup_s U_{p(s)}$. We may assume that U is contained in the ε -disk bundle, since the bundle is open in M^κ .

By claim 4.13, $p(s)$ is contained in precisely one cone section, say, C_i with boundary B_i and B_{i+1} . Note that $V = U \cap [C_i - (B_i \cup B_{i+1})]$ is contained in $W(p, q)^\kappa$, and that it is path connected.

1) Assume that $s \mapsto p(s)$ enters and leaves C_i at points in V . Then there is a $\delta > 0$ such that $\rho(s_j - (-1)^j \delta) \in M(q, p)$, for $j = 1, 2$. Let m_1 and m_2 denote the points on these flow lines corresponding to the level κ . Since $m, m' \in V$ we may redefine ρ on $[s_1 + \delta, s_2 - \delta]$ such that it becomes a curve in $M(q, p)$.

2) Assume that $s \mapsto p(s)$ enters C_i through B_i and leaves C_i through B_{i+1} , and let $\delta > 0$ be such that $p(s^1) \in B_i$ and $p(s^2) \in B_{i+1}$, with $s^j = s_j - (-1)^j \delta$. Now using the gluing map G of lemma 4.3 we continuously deform $\rho(s^1)$ and $\rho(s^2)$ to non-broken flow lines. Note then that $G(\rho(s^j); u)(\kappa)$ is in the interior of C_i for $u > 0$, since otherwise this would violate claim 4.13. Setting $G(\rho(s^j); u_0)(\kappa) =$

m_j for some fixed $u_0 > 0$, we may use case 1 above to redefine ρ on S such that it becomes a curve with chain length at most three.

Since the symmetric cases $-p(s)$ enters (resp. leaves) through the boundary and leaves (resp. enters) through the interior- and the cases $-p(s)$ enter and leave through B_i (resp. B_{i+1})- is proven similar to the above, we conclude that ρ may be redefined on S such that it becomes a curve in $\overline{M}(q, p)$ with chain length at most three. With similar arguments we obtain the same conclusion in the case $\lambda_b = 2$ and $\lambda_a = 1$.

By lemma 4.11 we are done if it can be proven that the family consisting of sub-intervals of I defined as S above, is finite. This technical argument is similar to that given at the beginning of the proof of lemma 4.9. \square

Chapter 5

Estimating the number of path components of the space of broken flow lines

In this chapter we show how to estimate the number of path components of the space of broken flow lines. Moreover, the estimate can be computed explicitly (i.e. as a number) if the Morse data is known a priori (by the Morse data we mean all critical points and intersection numbers).

Throughout this chapter M denotes an orientable closed 3-manifold and $f : M \rightarrow \mathbb{R}$ denotes a self indexing Morse-Smale function with only one minimum q and one maximum p . We will assume that the Riemannian metric is compatible with the Morse charts.¹ For a space S we write $\#S$ for the number of path components (or the number of elements if S is a finite set), and let $\mathbf{a} = \text{Crit}_1(f)$ and $\mathbf{b} = \text{Crit}_2(f)$

In section 5.1 we define three graphs, each embedded on different level surfaces, and discuss some basic properties of these graphs. The graphs will play an important role in section 5.2 where we show how to estimate $\#\bar{M}(q, p)$, the number of path components of $\bar{M}(q, p)$.

¹This assumption is included since we wish to use proposition 4.10.

5.1 Graphs on level surfaces

We start this section by separating (according to dimension) the various moduli spaces into three different sets.

First assume that there are no one dimensional moduli spaces homeomorphic to \mathbb{S}^1 and let the edge set E be the (disjoint) union of $E^1 = \cup_{a \in \mathbf{a}} \pi_0(\mathbf{M}(p, a))$ and $E^2 = \cup_{b \in \mathbf{b}} \pi_0(\mathbf{M}(b, q))$. Hence an element $e \in E$, called an edge, is a path component of a one dimensional moduli space, i.e. homeomorphic to the open interval $]0, 1[$.

The vertex set V is the (disjoint) union of $V^u = \cup_{b \in \mathbf{b}} \pi_0(\mathbf{M}(p, b))$, $V^m = \cup_{(b,a) \in \mathbf{b} \times \mathbf{a}} \pi_0(\mathbf{M}(b, a))$ and $V^l = \cup_{a \in \mathbf{a}} \pi_0(\mathbf{M}(a, q))$. Hence an element $v \in V$, called a vertex, is a path component of a zero dimensional moduli space, i.e. homeomorphic to a point. Note that for V^u and V^l the use of π_0 is in fact redundant since $\mathbf{M}(p, b)$ and $\mathbf{M}(a, q)$ are discrete two point spaces.

Finally we let $F = \pi_0(\mathbf{M}(p, q))$ be the face set, hence an element of F , called a face, is a path component of the two dimensional moduli space $\mathbf{M}(p, q)$.

5.1 Remark: If there were a one dimensional moduli space, say $\mathbf{M}(b, q)$, homeomorphic to \mathbb{S}^1 then we could add $\pi_0(\mathbf{M}(b, q) - *)$ to E and add the point $*$ to V . However, we choose to assume throughout that there are no such moduli spaces, simply because it will have no effect on the computations in this chapter.

Moreover, the boundary of $e \in E$ in the sense of theorem 2.1 consists of (v, u) and (v', u') both pairs in $V \times V$ with $(v, u) \neq (v', u')$ (see figure 5.1 below). ■

We can now define the following three graphs: The (upper) graph H with vertex set $V(H) = V^u$ and edge set $E(H) = E^1$, the (middle) graph Γ with vertex set $V(\Gamma) = V^m$ and edge set $E(\Gamma) = E$, and the (lower) graph G with vertex set $V(G) = V^l$ and edge set $E(G) = E^2$.

5.2 Remark: The graphs above are in general not simple graphs, e.g. if $e \in E$ with say $e \in E^1$ and boundary (v, u') , (v, u) then e is a simple edge (with vertices u' and u) in Γ , and a pseudo edge (with vertex v) in H (see the right side of figure 5.1 below). Moreover, if $e' \in E^2$ has boundary (u', w') , (u, w) then e and e' are parallel edges in Γ .

Moreover, note that² $\#\mathbf{a} = \#\mathbf{b}$. This number will be denoted by g in the sequel. ■

²See 5.3.1 in the appendix of this chapter.

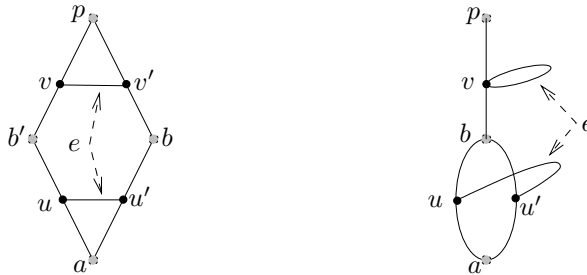

Figure 5.1:

The terms upper, middle and lower are due to the following. For $i = 1, 2, 3$ let $\tau_i \in]i - 1, i[$, then $f^{-1}(\tau_i) \approx \mathbb{S}^2$ for $i = 1, 3$, and $f^{-1}(\tau_2) \approx \Sigma^g$ the orientable closed surface of genus g (see ([Mat02],p.173)). Now by identifying $M(p, a)$ with $W(p, a)^{\tau_3}$ (for each a), and $M(p, b)$ with $W(p, b)^{\tau_3}$ (for each b) we may consider the upper graph H as a subset of $\mathbb{S}^2 \approx f^{-1}(\tau_3)$. With similar identifications we also have $\Gamma \subset \Sigma^g$ and $G \subset \mathbb{S}^2$. Moreover, let $F_i, i = 1, 2, 3$, denote the face set of G, Γ and H respectively. With the above identifications we then have

$$F_1 = \mathbb{S}^2 - G = W(p, q)^{\tau_1}, \quad F_2 = \Sigma^g - \Gamma = W(p, q)^{\tau_2}, \quad F_3 = \mathbb{S}^2 - H = W(p, q)^{\tau_3}$$

Hence $F \approx F_i$ by claim 2.9. In particular, the number of faces corresponding to each graph is the same and equals $\#F = \#M(q, p) = \#\overline{M}(q, p)$ where the last equality is by proposition 4.10.

5.3 Remark: Let S denote any of the above surfaces and $K \subset S$ the corresponding graph. With the relative topology on K it is clear that $V(K) \cup E(K)$ constitute a CW-decomposition of K (see ([Dol80],p.89)), hence K can be considered as a one dimensional CW-complex. ■

The following result summaries some simple properties of the above defined graphs.

5.4 Claim.

Let S denote any of the above surfaces and $K \subset S$ the corresponding graph.

- 1) The graph K is planar.
- 2) If $K = G, H$ then $2g = \#V(K)$.

- 3) $\#V(\Gamma) = \#E(G) = \#E(H) = \#E(\Gamma)/2$.
- 4) For $v \in V(\Gamma)$ the valence $\text{val}(v)$ is equal to 4, hence the number of edges connected to v is either 2,3 or 4.
- 5) If $K = G, H$ and $v \in V(K)$ then $\text{val}(v) = \# \cup \mathbf{M}(b, a)$ where the union is taken over all $b \in \mathbf{b}$ if $v \in \mathbf{M}(a, q) \subset V(G)$ and over all $a \in \mathbf{a}$ if $v \in \mathbf{M}(p, b) \subset V(H)$.

Proof:

Ad 1): Since K can be described as $\cup_{\mathbf{W}} S \cap \mathbf{W}$ where \mathbf{W} run over all components of $\partial \mathbf{W}(p, q)$. Ad 2): Since $2 = \#\mathbf{M}(a, q) = \#\mathbf{M}(p, b)$ and $g = \#\mathbf{a} = \#\mathbf{b}$. Ad 3) For $K = G$ and $b \in \mathbf{b}$ let $U_b = \mathbb{E}^u \oplus \mathbb{E}^s$ be a Morse chart and $\mathbb{S}^1 \subset \mathbb{E}^u$. We may consider \mathbb{S}^1 as a graph with vertex set $V_b = \cup_a \mathbf{M}(b, a)$ and edge set $E_b = \pi_0(\mathbf{M}(b, q))$. Then $0 = \chi(\mathbb{S}^1) = \#V_b - \#E_b$ hence $\#V(\Gamma) = \sum_b \#V_b = \sum_b \#E_b = \#E(G)$. Almost identical arguments show that $\#V(\Gamma) = \#E(H)$. Moreover $\#E(\Gamma) = \#E(G) + \#E(H) = 2\#V(\Gamma)$. Ad 4): Let $v \in V(\Gamma)$ with $v \in \mathbf{M}(b, a)$, say. Since v is one of the points in the (transverse) intersection $\mathbf{W}^u(b) \pitchfork \mathbf{W}^s(a) \pitchfork \Sigma^g$, there is a chart $U_v = \mathbb{R} \times \mathbb{R}$ on Σ^g such that locally $\mathbf{W}^u(b)^\tau = \mathbb{R} \times \{0\}$ and $\mathbf{W}^s(a)^\tau = \{0\} \times \mathbb{R}$. Let X_\pm and Y_\pm denote the strictly positive/negative first and second axes, respectively. By choosing U_v such that $U_v \cap V(\Gamma) = \{v\}$, we see that each of the four sets X_\pm and Y_\pm represent part of an edge in $E(\Gamma)$. Hence $\text{val}(v) \geq 4$, but equality clearly holds. Ad 5): For $K = G$ and $v \in \mathbf{M}(a, q)$ each pair (v, u) , with $u \in \mathbf{M}(b, a)$, is in the boundary of a unique edge in E^2 , hence $\text{val}(v) = \#\{(v, u) \mid u \in \cup \mathbf{M}(b, a)\} = \# \cup \mathbf{M}(b, a)$. The case $K = H$ is similar. \square

5.5 Remark: Note that the method of proof in Ad 5) applies in Ad 4) as well. Moreover, Ad 3) follows from Ad 5) since

$$2\#E(K) = \sum_{v \in V(K)} \text{val}(v) = \sum_{b,a} \#\mathbf{M}(b, a) = 2\#V(\Gamma)$$

where the first equality follows from Euler's theorem (see e.g. ([GT87],p.4)). \blacksquare

5.2 Estimates of $\#\overline{M}(q, p)$

In the following two subsections we estimate the number $\#F = \#\overline{M}(q, p)$. As above we let S denote the surface \mathbb{S}^2 or Σ^g , and $K \subset S$ the corresponding graph.

5.2.1

In this subsection we estimate the number $\beta_0(F) = \#F$ by means of the upper/lower graph. Let $\mathbb{H}(\cdot) = \mathbb{H}(\cdot; \mathbb{Z})$ denote singular (co)homology and $\chi(\cdot)$ the Euler characteristic.

Since S is a compact orientable manifold and $K \subset S$ is closed we may apply the Poincare-Lefschetz duality diagram from ([Bre93],p.352) to obtain the following diagram with exact rows³

$$\begin{array}{cccccccccccc}
 \mathbb{H}^0(S, K) & \rightarrow & \mathbb{H}^0(S) & \rightarrow & \mathbb{H}^0(K) & \rightarrow & \mathbb{H}^1(S, K) & \rightarrow & \mathbb{H}^1(S) & \longrightarrow & \mathbb{H}^1(K) & \longrightarrow & \mathbb{H}^2(S, K) & \rightarrow & \mathbb{H}^2(S) & \rightarrow & \mathbb{H}^2(K) \\
 \downarrow \approx & & \downarrow \approx & & \downarrow \approx & & \downarrow \approx & & \downarrow \approx & & \downarrow \approx & & \downarrow \approx & & \downarrow \approx & & \downarrow \approx \\
 \mathbb{H}_2(F) & \rightarrow & \mathbb{H}_2(S) & \rightarrow & \mathbb{H}_2(S, F) & \rightarrow & \mathbb{H}_1(F) & \rightarrow & \mathbb{H}_1(S) & \longrightarrow & \mathbb{H}_1(S, F) & \longrightarrow & \mathbb{H}_0(F) & \rightarrow & \mathbb{H}_0(S) & \rightarrow & \mathbb{H}_0(S, F) \\
 \parallel & & \parallel & & \parallel & & \parallel & & \parallel & & \parallel & & \parallel & & \parallel & & \parallel \\
 0 & & \mathbb{Z} & & \mathbb{Z}^{\beta_0(K)} & & 0, \mathbb{Z}^{2g} & & \mathbb{Z}^{\beta_0(K) - \chi(K)} & & & & \mathbb{Z} & & & & 0
 \end{array}$$

Starting from the left: 0 because ([Bre93],p.346), the next two are clear, the fourth stands for the cases $S = \mathbb{S}^2, \Sigma^g$, the fifth follows from $\chi(K) = \beta_0(K) - \beta_1(K)$, and the last two are clear.

With $K = G, H$ we have from the above diagram that $\mathbb{H}_0(F) = \mathbb{Z}^{\beta_0(K) - \chi(K)} \oplus \mathbb{Z}$ hence

$$\#F = \beta_0(F) = \beta_0(K) - \chi(K) + 1 = \begin{cases} \beta_1(K) + 1 \\ \beta_0(K) - \#V(K) + \#E(K) + 1 \\ \beta_0(K) - 2g + \#V(\Gamma) + 1 \end{cases} \tag{5.1}$$

where the second equality (in the bracket) follows from $\beta_0(K) - \beta_1(K) = \chi(K) = \#V(K) - \#E(K)$, and the last equality follows from 2) and 3) of claim 5.4.

5.6 Remark: The above equation for $\#F$ could also be deduced from the formula for $\chi(K)$ and the polyhedral formula $1 = \#V(K) - \#E(K) + \#F(K) - \beta_0(K)$ which holds for any planar graph K on \mathbb{S}^2 . ■

The question now is whether we can compute the entries in the formulas for $\#F$ given by (5.1). Let us start with the special case where each face is simply connected.

³In ([Bre93],p.352) the first row of the diagram is given in terms of Čech cohomology. But S and K are both ENR's, hence Čech cohomology coincides with ordinary cohomology ([Dol80],p.285).

5.7 Claim.

Each face is simply connected iff $K = G$ or $K = H$ is connected.

Proof:

By ([Bre93],p.346(7.13)) $H_1(F)$ is free, hence by the above diagram $H_1(F) \oplus \mathbb{Z} = \mathbb{Z}^{\beta_0(K)}$ with $K = G$ or $K = H$. \square

Hence in this case $\#F = 2 - 2g + \#V(\Gamma)$. Moreover, the computation of $\#V(\Gamma) = \sum_i \sum_j \#M(b_i, a_j)$ is given in terms of the boundary operator ∂ from Morse Homology. Recall from section 1.3 that in general

$$\partial c = \sum_{\substack{c' \in \text{Crit}_{\lambda_{c-1}}(f) \\ x \in M(c, c')}} n(x)c' = \sum_{c' \in \text{Crit}_{\lambda_{c-1}}(f)} n(c, c')c'$$

where $n(c, c') = \sum_{x \in M(c, c')} n(x)$ with $n(x) = \pm 1$ denotes the intersection number of the stable and unstable spheres. So if we define

$$\bar{\partial} c = \sum_{\substack{c' \in \text{Crit}_{\lambda_{c-1}}(f) \\ x \in M(c, c')}} |n(x)| = \sum_{c' \in \text{Crit}_{\lambda_{c-1}}(f)} \#M(c, c') \in \mathbb{Z}$$

we may compute $\#V(\Gamma)$ by

$$\bar{\partial} \sum_i b_i = \sum_i \bar{\partial} b_i = \sum_i \sum_j \#M(b_i, a_j) = \#V(\Gamma)$$

That is, given the data from Morse homology, $\#F = \#\overline{M}(q, p)$ can be computed in the special case where each face is simply connected.

In general we have to compute $\beta_0(K)$ because $\#F = \beta_0(K) - 2g + \#V(\Gamma) + 1$. Unfortunately the Morse data does not contain enough information for this computation to be carried out, but in section 5.2.2 we will show how one can estimate $\#F$ using the Morse data.

5.8 Remark: If we in addition to the Morse data know the explicit vertices corresponding to each edge we may in fact compute $\beta_0(K)$ as follows. Let K' be the graph obtained from K by adding one point to every parallel edge and two points to every pseudo edges in K . This will not effect the formula for $\#F$, and K' is then a simple graph with $\beta_0(K') = \beta_0(K)$. Now let D denote the incidence matrix of K' . By ([Big93],p.24) we then have $\text{Rank}(D) = \#V(K) - \beta_0(K')$, so $\beta_0(K')$ can be computed in this case. \blacksquare

We end this section with a minor result concerning the connectivity of Γ .

5.9 Claim.

If $K = G$ or $K = H$ is connected, then Γ is connected.

Proof:

Assume that $K = G$ or $K = H$ is connected, then by the Poincare-Lefschetz duality diagram

$$0 \longrightarrow \mathbb{Z}^{2g} \longrightarrow \mathbb{Z}^{\beta_0(\Gamma) - \chi(\Gamma)} \longrightarrow \mathbb{H}_0(F) \longrightarrow \mathbb{Z} \longrightarrow 0$$

where $\mathbb{H}_0(F) = \mathbb{Z}^{1 - \chi(K)} \oplus \mathbb{Z}$. Hence

$$\begin{array}{ccccccccc} 0 & \longrightarrow & \mathbb{Z}^{2g} & \longrightarrow & \mathbb{Z}^{\beta_0(\Gamma) - \chi(\Gamma)} & \longrightarrow & \mathbb{Z}^{1 - \chi(K)} \oplus \mathbb{Z} & \longrightarrow & \mathbb{Z} & \longrightarrow & 0 \\ & & & & \downarrow & \nearrow & & & & & \\ & & 0 & \longrightarrow & \mathbb{Z}^{\beta_0(\Gamma) - \chi(\Gamma)} / \mathbb{Z}^{2g} & & & & & & \\ & & & & \downarrow & & & & & & \\ & & & & 0 & & & & & & \end{array}$$

and so $1 - \chi(K) = \beta_0(\Gamma) - \chi(\Gamma) - 2g$. But $1 - \chi(K) = 1 - \#V(K) + \#E(K) = 1 - 2g + \#V(\Gamma)$ and $\beta_0(\Gamma) - \chi(\Gamma) - 2g = \beta_0(\Gamma) + \#V(\Gamma) - 2g$, hence

$$1 - 2g + \#V(\Gamma) = \beta_0(\Gamma) + \#V(\Gamma) - 2g \quad \Rightarrow \quad \beta_0(\Gamma) = 1$$

hence proving the claim. \square

5.2.2

In this subsection we show how to estimate the number $\beta_0(F) = \#F$ by means of the middle graph. In this section all (co)homology groups are real vector spaces i.e. the coefficient group is \mathbb{R} . Now the duality diagram of the last section gives the exact sequence (with $\Sigma^g = \Sigma$)

$$\mathbb{H}^1(\Sigma) \xrightarrow{i^*} \mathbb{H}^1(\Gamma) \rightarrow \mathbb{H}_0(F) \rightarrow \mathbb{H}^2(\Sigma) \rightarrow 0$$

where $i : \Gamma \hookrightarrow \Sigma$ is the inclusion. Hence we have the short exact sequence $0 \rightarrow \text{coker}(i^*) \rightarrow \mathbb{H}_0(F) \rightarrow \mathbb{H}^2(\Sigma) \rightarrow 0$ which splits since we are dealing with finite⁴

⁴The (co)homology groups of Γ and Σ are finitely generated since Γ is a finite CW-complex and Σ is a compact manifold ([Bre93], p.538).

dimensional vector spaces, so $\#F = \beta_0(F) = \dim(\text{coker}(i^*)) + 1$. Moreover, by a standard duality argument⁵ $\text{coker}(i^*) \approx \ker(i_*)$, where $i_* : \mathbb{H}_1(\Gamma) \rightarrow \mathbb{H}_1(\Sigma)$, hence

$$\begin{aligned} \#F &= \dim(\ker(i_*)) + 1 = \beta_1(\Gamma) - \dim(\text{im}(i_*)) + 1 \\ &= \beta_0(\Gamma) + \#V(\Gamma) - \dim(\text{im}(i_*)) + 1 \end{aligned} \quad (5.2)$$

where the last equality follows from the fact that $\beta_0(\Gamma) - \beta_1(\Gamma) = \chi(\Gamma) = \#V(\Gamma) - \#E(\Gamma)$ and claim 5.4. We claim that each term in the formula (5.2) for $\#F$ can be computed using the Morse data (recall that we have already dealt with the case $\#V(\Gamma)$).

For $\beta_0(\Gamma)$: Write $\mathbb{S}_i^s = \mathbb{W}^s(a_i)^{\tau_2}$ and $\mathbb{S}_i^u = \mathbb{W}^u(b_i)^{\tau_2}$ for each $a_i \in \mathbf{a}$ and $b_i \in \mathbf{b}$, respectively, and note that $\Gamma = (\cup_i \mathbb{S}_i^s) \cup (\cup_i \mathbb{S}_i^u)$. Now define the bipartite graph Γ' as follows. Let each (un)stable sphere correspond to a vertex and let there be an edge between two vertices if the corresponding stable and unstable spheres intersects (see figure 5.2 below). Note then that the existence of an edge is

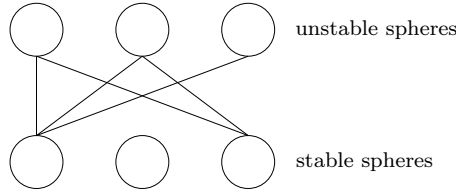

Figure 5.2: The graph Γ' .

equivalent to the existence of a one dimensional flow line, so this information is contained in the Morse data. Hence we can construct Γ' explicitly and therefore also calculate $\beta_0(\Gamma')$, but $\beta_0(\Gamma') = \beta_0(\Gamma)$ clearly.

For $\dim(\text{im}(i_*))$: Let notation be as in the above paragraph, and let $s_i = i_*[\mathbb{S}_i^s] \in \mathbb{H}_1(\Sigma)$ where $[\mathbb{S}_i^s]$ denotes the image of the fundamental class $[\mathbb{S}^1] \in \mathbb{H}_1(\mathbb{S}^1)$ under the diffeomorphism $\mathbb{S}^1 \rightarrow \mathbb{S}_i^s \subset \Gamma$. It is standard⁶ that half the generators of $\mathbb{H}_1(\Sigma)$ can be chosen as $\{s_i\} = \{s_1, s_2, \dots, s_g\}$, hence $\{s_i\}$ generates a subspace of $\text{im}(i_*)$ of dimension g .

Now let $I : \mathbb{H}_1(\Sigma) \times \mathbb{H}_1(\Sigma) \rightarrow \mathbb{R}$ denote the intersection form, this is a bilinear form which is antisymmetric and non-degenerate since we are in the middle

⁵See 5.3.2 in the appendix of this chapter.

⁶See e.g. ([Hat02],p.205)

dimension, ([Mat02],p.163). With respect to I we may therefore form the dual basis $\{s_i^*\} = \{s_1^*, s_2^*, \dots, s_g^*\}$ of $\{s_i\}$, hence $\{s_i, s_i^*\} = \{s_1, \dots, s_g, s_1^*, \dots, s_g^*\}$ is a basis for $H_1(\Sigma)$ under the following identification. First complete $\{s_i\}$ to a basis $\{s_i, s'_i\}$ of $H_1(\Sigma)$ and use the coordinate isomorphism $H_1(\Sigma) \approx \mathbb{R}^{2g}$ taking s_i (resp. s'_i) to e_i (resp. e_{i+g}), where $\{e_1, e_2, \dots, e_{2g}\}$ denotes the standard basis for \mathbb{R}^{2g} . Next, form the (external) direct sum $V \oplus V^*$, with $V = \text{span}\{s_i\}$, $V^* = \text{span}\{s_i^*\}$, and use a coordinate isomorphism $V \oplus V^* \approx \mathbb{R}^{2g}$ similar to the above.

5.10 Remark: Note that $(H_1(\Sigma), I)$ is in fact a symplectic vector space, and that $V = \text{span}\{s_i\} \subset H_1(\Sigma)$ is a Lagrangian subspace. Hence we could have used a standard result from linear symplectic geometry to conclude that $\{s_i, s_i^*\}$ is a (symplectic) basis for $H_1(\Sigma)$, see e.g. ([MS98],Ch.2.1) \blacksquare

Now let $u_i = i_*[S_i^u] \in H_1(\Sigma)$ then $u_i = \sum_j \alpha_{ij} s_j + \sum_j \beta_{ij} s_j^*$ and $\text{span}\{s_1, \dots, s_g, u_1, \dots, u_g\}$ is a subspace of $\text{im}(i_*)$. Therefore

$$g + \dim(\text{span}\{u_i\}) = g + \text{Rank}([\beta_{ij}]) \leq \dim(\text{im}(i_*)) \leq 2g$$

But the matrix $[\beta_{ij}]$ is know explicitly since $\beta_{ij} = I(u_i, s_j)$ and $I(u_i, s_j) = \sum_{x \in M(b_i, a_j)} n(x)$. That is $[\beta_{ij}]$ is the matrix of the boundary operator $\partial_2 : C_2(f, \mathbb{R}) \rightarrow C_1(f, \mathbb{R})$ from Morse homology, hence $\text{Rank}([\beta_{ij}]) = \dim(\text{im}(\partial_2))$. Moreover, since M is assumed to be orientable and f only has one minimum and one maximum we see that $\partial_1 = 0$ (and for that matter $\partial_3 = 0$). So $\dim(\text{im}(\partial_2)) = g - \beta_1(M)$, since the canonical projection

$$\ker(\partial_1) \rightarrow \ker(\partial_1)/\text{im}(\partial_2) = H_1(M)$$

is a linear surjection with kernel $\text{im}(\partial_2)$. In summary we have therefore proven

5.11 Lemma.

Let $\dim(M) = 3$ and $f : M \rightarrow \mathbb{R}$ be a self indexing Morse-Smale function with only one minimum q and one maximum p . The following estimate for $\#\overline{M}(q, p)$, the number of path components of the space of broken flow lines, holds

$$\beta_0(\Gamma) + \#V(\Gamma) - 2g + 1 \leq \#\overline{M}(q, p) \leq \beta_0(\Gamma) + \#V(\Gamma) - 2g + \beta_1(M) + 1 \quad (5.3)$$

In particular, $\#\overline{M}(q, p) = \beta_0(\Gamma) + \#V(\Gamma) - 2g + 1$ if M is simply connected.

Moreover, by combining (5.1) and (5.3) we have the following corollary

5.12 Corollary.

For $K = G, H$ it holds that $\beta_0(\Gamma) \leq \beta_0(K) \leq \beta_0(\Gamma) + \beta_1(M)$. In particular, $\beta_0(\Gamma) = \beta_0(K)$ if M is simply connected.

5.3 Appendix

In this appendix we prove (for completeness) some standard facts stated in the main text.

5.3.1

We prove that $\#\mathbf{a} = \#\mathbf{b}$. Let $C = \{C_i\}$ denote the Morse-Smale-Witten chain complex. By ([Spa81],p.172) we have $\chi(C) = \chi(\mathbb{H}(C))$ (with $\mathbb{H}(C) = \mathbb{H}(M)$ of course), thus

$$\sum_{i=0}^3 (-1)^i \text{Rank}(C_i) = \sum_{i=0}^3 (-1)^i \text{Rank}(\mathbb{H}_i(C))$$

But the left hand side is equal to $\text{Rank}(C_2) - \text{Rank}(C_1) = \#\mathbf{b} - \#\mathbf{a}$ since there is only one minimum/maximum, and the right hand side is zero by duality of Betti numbers (see e.g. ([Mat02],p.158)).

5.3.2

We prove that $\text{coker}(i^*) \approx \ker(i_*)$ by the universal coefficient theorem (UCT) ([Bre93],p.282). Let $(i_*)^*$ denote the dual map (wrt. $\text{hom}(\cdot, \mathbb{R})$) of i_* . By the UCT we have the commutative diagram

$$\begin{array}{ccc} \mathbb{H}^1(\Sigma) & \xrightarrow{\approx} & \text{hom}(\mathbb{H}_1(\Sigma), \mathbb{R}) = \mathbb{H}_1(\Sigma)^* \\ \downarrow i^* & & \downarrow (i_*)^* \\ \mathbb{H}^1(\Gamma) & \xrightarrow{\approx} & \text{hom}(\mathbb{H}_1(\Gamma), \mathbb{R}) = \mathbb{H}_1(\Gamma)^* \end{array}$$

and by applying the hom functor $\text{hom}(\cdot, \mathbb{R})$ to this diagram we obtain the commutative diagram

$$\begin{array}{ccccc}
 \mathbb{H}^1(\Sigma)^* & \xrightarrow{\approx} & \mathbb{H}_1(\Sigma)^{**} & \xrightarrow{\approx} & \mathbb{H}_1(\Sigma) \\
 \uparrow (i^*)^* & & \uparrow (i_*)^{**} & & \uparrow i_* \\
 \mathbb{H}^1(\Gamma)^* & \xrightarrow{\approx} & \mathbb{H}_1(\Gamma)^{**} & \xrightarrow{\approx} & \mathbb{H}_1(\Gamma)
 \end{array}$$

where the right square arises from the fact that we are dealing with finite dimensional vector spaces. Hence $\ker((i^*)^*) \approx \ker(i_*)$.

Now $\mathbb{H}^1(\Sigma) \xrightarrow{i^*} \mathbb{H}^1(\Gamma) \xrightarrow{\pi} \text{coker}(i^*) \rightarrow 0$ is exact, where π is the quotient map. Hence $0 \rightarrow \text{coker}(i^*)^* \xrightarrow{\pi^*} \mathbb{H}^1(\Gamma)^* \xrightarrow{(i^*)^*} \mathbb{H}^1(\Sigma)^*$ is exact since $\text{hom}(\cdot, \mathbb{R})$ is right exact. Therefore $\text{coker}(i^*)^* \approx \text{im}(\pi^*) \approx \ker((i^*)^*)$ and so $\text{coker}(i^*) \approx \text{coker}(i^*)^* \approx \ker(i_*)$.

Chapter 6

Main results and future work

In this chapter we give a brief description of the main results of each chapter, together with suggestions on what might be the focus of future work. We refer to section A.3 regarding future work related to the result of appendix A.

6.1 Chapter 2

For a given Morse-Smale pair (f, g) on a closed manifold, it was shown that the moduli space $\mathbf{M}(p, q)$ (of orbits from $p \in \text{Crit}(f)$ to $q \in \text{Crit}(f)$) can be embedded as a subspace, with compact closure, of a space having the Hausdorff topology, i.e. the closure $\overline{\mathbf{M}(p, q)}$ is a compactification of $\mathbf{M}(p, q)$ with respect to Hausdorff topology. Moreover, the space of height-parameterized flow lines $M(q, p)$ (from q to p) has compact closure with respect to the compact open topology, and there exists a homeomorphism between $M(q, p)$ and $\mathbf{M}(p, q)$ which extends to the closures of these spaces in their respective topologies. So the closures $\overline{M(q, p)}$ and $\overline{\mathbf{M}(p, q)}$ are homeomorphic compactifications of both $M(q, p)$ and $\mathbf{M}(p, q)$. Finally it was shown that the space of broken flow lines $\overline{M}(q, p)$ (from q to p) is compact with respect to the compact open topology, and contains $M(q, p)$ as an open and dense subspace. In particular, $\overline{M}(q, p)$ can be considered as a compactification of both $M(q, p)$ and $\mathbf{M}(p, q)$.

Even though $\overline{M}(q, p)$ has some nice properties, e.g. it is a compact metric space, we do not know whether $\overline{M}(q, p)$ has a fundamental property such as being

an ENR (Euclidean Neighborhood Retract). Hence a more detailed study of $\overline{M}(q, p)$ could be the focus of future work. Moreover, it seems that there is a widespread agreement that $M(q, p)$ has a compactification as a compact smooth manifold with corners (see e.g. ([AB95],p.130) or ([Hut02],p.10), and compare with section 2.5.1). Unfortunately, I have not been able to find any proof of this. On the basis of the above I speculate that the following conjecture holds

6.1 Conjecture.

The space of broken flow lines has the structure of a smooth manifold with corners.

Certainly this conjecture could form the basis for future work. Note that if the conjecture holds then $\overline{M}(q, p)$ is an ENR, so in chapter 3 we may use ordinary singular cohomology instead of Čech cohomology, and therefore replace “connected” with “path connected” in corollary 3.15. Moreover, the surjectivity result of section 4.2 (corollary 4.7) would be obvious since $\overline{M}(q, p)$ is locally path connected. Note also the important fact that duality theorems are at hand.

Besides the above mentioned references I believe that [Lat94],[Lau04], [Sch99], [Lu04], [BC03] and [BC06] could be helpful in an attempt to prove this conjecture.

Finally, it could also be interesting to see how perturbations of f and g would affect $\overline{M}(q, p)$.

6.2 Chapter 3

For a given Morse-Smale pair (f, g) on a closed n -manifold with f having precisely one critical point q of index 0 and one critical point p of index n , it was shown that the space of broken flow lines $\overline{M}(q, p)$ is connected if f has no critical points of index 1 or $n - 1$.

The above result says nothing when there are critical points of index 1 or $n - 1$. Hence this situation could be the focus of future work. At present the methods used in this chapter do not seem sufficient. I speculate that a Mayer-Vietoris like argument would be helpful. More precisely, the Mayer-Vietoris sequence could provide some information (regarding $H_0(\overline{M}(q, p))$ at least), if one could find a suitable open neighborhood of the subspace of $\overline{M}(q, p)$ consisting of flow lines with chain length at least three (that is, of $\overline{M}(q, p) - M(q, p)$). If one could prove that $\overline{M}(q, p)$ is a (B)-prestratification (i.e. a Whitney prestratification) with

subsets of $\overline{M}(q, p) - M(q, p)$ as strata, then the system of tubular neighborhoods described in ([Mat73], Ch.II.6) might be a candidate for such a neighborhood.

6.3 Chapter 4

For a given Morse-Smale pair (f, \mathbf{g}) on a closed n -manifold with \mathbf{g} compatible with the Morse charts, and f having precisely one critical point q of index 0 and one critical point p of index n , it was shown that the inclusion of the space of height-parameterized flow lines $M(q, p)$ into the space of broken flow lines $\overline{M}(q, p)$ induces a surjection on π_0 . This was a consequence of a gluing procedure for height-parameterized flow lines. If in addition f is self indexing, then the inclusion $M(q, p) \hookrightarrow (M(q, p) \cup B^1 \cup B^2)$ induces a bijection on π_0 , where $B^1 \subset \overline{M}(q, p)$ denotes the subspace whose elements have chain length three and $B^2 \subset \overline{M}(q, p)$ denotes the subspace whose elements have chain length four, say $\{q, a, b, p\}$, with either $\lambda_a = 1$ and $\lambda_b = 2$, or $\lambda_a = n - 2$ and $\lambda_b = n - 1$. If the assumption on \mathbf{g} is omitted then $M(q, p) \hookrightarrow (M(q, p) \cup A^1)$ (and $M(q, p) \hookrightarrow \overline{M}(q, p)$ if $n = 3$) induces an injection on π_0 , where $A^1 \subset \overline{M}(q, p)$ denotes the subspace whose elements have chain length three, say $\{q, a, p\}$, with either $\lambda_a = 1$ or $\lambda_a = n - 1$.

It is clear that the following conjecture should be the aim of future work.

6.2 Conjecture.

The inclusion $M(q, p) \hookrightarrow \overline{M}(q, p)$ induces a bijection on π_0 .

Note that this will be a step towards determining $H_0(\overline{M}(q, p))$. I believe that a proof of this conjecture is within reach if one can generalize the ‘‘cone construction’’ in lemma 4.12. In this direction I think that the appendix (by Laudenbach) in [BZ92] could be helpful.

6.4 Chapter 5

For a given Morse-Smale pair (f, \mathbf{g}) on an orientable closed 3-manifold with \mathbf{g} compatible with the Morse charts, and f self indexing with precisely one critical point q of index 0 and one critical point p of index n , it was shown that the number of path components of the space of broken flow lines $\#\overline{M}(q, p)$ can be

estimated by

$$\beta_0(\Gamma) + \#V(\Gamma) - 2g + 1 \leq \#\overline{M}(q, p) \leq \beta_0(\Gamma) + \#V(\Gamma) - 2g + \beta_1(\mathbf{M}) + 1 \quad (6.1)$$

where $g = \#\text{Crit}_1(f) = \#\text{Crit}_2(f)$, β_i denotes the i 'th Betti number, and $V(\Gamma)$ denotes the set of 0-cells of the one dimensional CW-complex Γ defined by

$$\Gamma = [\cup_i(\mathbf{W}^s(a_i) \pitchfork f^{-1}(\tau_2))] \cup [\cup_i(\mathbf{W}^u(b_i) \pitchfork f^{-1}(\tau_2))]$$

with $\text{Crit}_1(f) = \{a_1, a_2, \dots, a_g\}$, $\text{Crit}_2(f) = \{b_1, b_2, \dots, b_g\}$ and $\tau_2 \in]1, 2[$. So

$$\#\overline{M}(q, p) = \beta_0(\Gamma) + \#V(\Gamma) - 2g + 1$$

if \mathbf{M} is simply connected. Moreover, each term in the formula (6.1) can be computed explicitly (i.e. as a number) if all critical points and intersection numbers are known a priori.

Regarding future work, recall that the estimate (6.1) was due to

$$\#\overline{M}(q, p) = \beta_0(\Gamma) + \#V(\Gamma) - \dim(\text{im}(i_*)) + 1 \text{ and } 2g - \beta_1(\mathbf{M}) \leq \dim(\text{im}(i_*)) \leq 2g$$

where $i_* : \mathbf{H}_1(\Gamma) \rightarrow \mathbf{H}_1(f^{-1}(\tau_2))$ and i is the inclusion. Hence to improve the estimate (6.1) one could try to improve the estimate for $\dim(\text{im}(i_*))$. For this [GRS03] might be a useful reference.

Appendix A

In this appendix we prove that the closure of any unstable manifold is a pre-stratified space which is (A)-regular at any noncritical point. This appendix is unrelated to the results obtained in the main text.

I have benefited greatly from discussions with Dr. Lukáš Vokřínek, regarding the results obtained here.

Throughout this appendix let $f : M \rightarrow \mathbb{R}$ be a Morse function on a closed n -manifold M and g a compatible Riemannian metric on M such that (f, g) is Morse-Smale.

A.1 Stratification

Let X be a 2^{nd} countable paracompact T_2 -space. A prestratification¹ of X is a pair (X, \mathcal{P}) where \mathcal{P} is a partition of X into subsets, called strata. For a prestratification (X, \mathcal{P}) we say that X is a prestratified space (with respect to \mathcal{P}). When the space X is understood we simply write \mathcal{P} for the prestratification. A prestratification is usually assumed to satisfy the following three conditions

P1) Each stratum $\mathcal{U} \in \mathcal{P}$ is locally closed.

P2) \mathcal{P} is locally finite.

P3) Let $\mathcal{V}, \mathcal{U} \in \mathcal{P}$. If $\mathcal{V} \cap \overline{\mathcal{U}} \neq \emptyset$, then $\mathcal{V} \subseteq \overline{\mathcal{U}}$. In this case we write $\mathcal{V} \leq \mathcal{U}$.

¹See ([Mat73],p.199)

A prestratification (X, \mathcal{P}) is called a decomposition of X with pieces $U \in \mathcal{P}$ if it satisfies the above conditions and each stratum is a manifold (in the induced topology).²

Now consider the triple (U, V, x) , where U and V (with $x \in V$) are submanifolds of a manifold X , and recall that the Whitney condition (A) on (U, V, x) is:³

Whitney's condition (A): If $\{x_i\} \subset U$ with $x_i \rightarrow x$ and $T_{x_i}U \rightarrow T$, then $T_xV \subseteq T$.

Here the convergence $T_{x_i}U \rightarrow T$ is in the Grassmannian of $\dim(U)$ -dimensional subspaces of TX . In the above case we say that (U, V, x) is (A)-regular at x , and (A)-regular if it is (A)-regular at x for all $x \in V$. We are now able to define the notation of an (A)-prestratification.

Let X be a manifold with $X' \subseteq X$. A prestratification (X', \mathcal{P}) is said to be an (A)-prestratification if \mathcal{P} is a decomposition (of X'), and (U, V) is (A)-regular for every $U, V \in \mathcal{P}$ with $V \leq U$. In this case we say that X' is an (A)-prestratified space.

A.2 The main result

Recall from section 1.3 that $(\text{Crit}(f), \geq)$ is a poset with $a \geq b$ iff $W(a, b) \neq \emptyset$ and that

$$\overline{W^u(a)} = \bigcup_{a \geq b} W^u(b) \tag{A.1}$$

as a consequence of the λ -lemma. The main result of this appendix is then;

A.1 Lemma.

Let $f : M \rightarrow \mathbb{R}$ be a Morse function on a closed n -manifold M and g a Riemannian metric on M such that (f, g) is Morse-Smale and g is compatible with the Morse charts. Consider the prestratification $(\overline{W^u(a)}, \mathcal{P})$ where

$$\mathcal{P} = \{W(b)\}_{b \in \text{Crit}(f): a \geq b} \tag{A.2}$$

Let $(W^u(p), W^u(q))$ be any pair with $W^u(p), W^u(q) \in \mathcal{P}$ and $W^u(q) \leq W^u(p)$. The triple $(W^u(p), W^u(q), m)$ is (A)-regular for any $m \neq q$.

²See ([Pfl01], p.15)

³See ([Mat73], p.203) or ([Pfl01], p.36)

The proof of this lemma will consist of the following three claims.⁴

A.2 Claim.

The pair $(\overline{W^u(a)}, \mathcal{P})$ is a decomposition.

Proof:

By the Morse-Smale condition each stratum is a submanifold of M , so they lie locally closed in M and therefore also in $\overline{W^u(a)}$ (of course in the induced topology) hence P1). Condition P2) follows from (A.2), since M is compact, and P3) is a consequence of (A.1). This proves the claim. \square

Now let $(W^u(p), W^u(q))$ be as in lemma A.1, hence $p \geq q$ so $W^u(p) \pitchfork W^s(q)$. We will prove that $(W^u(p), W^u(q), m)$ is (A)-regular at $m \neq q$. Therefore let $\{m_i\} \subset W^u(p)$ with $m_i \rightarrow m \in W^u(q)$ and $T_{m_i}W^u(p) \rightarrow T$, hence we need to prove that $T_mW^u(q) \subseteq T$. We proceed by showing that lemma A.1 is true whenever $m \neq q$ is contained in a Morse chart.

A.3 Claim.

If $m \in W^u(q) - \{q\}$ be contained in a Morse chart around q , then $T_mW^u(q) \subseteq T$.

Figure 4.5 on page 65 can to some extent be helpful in visualizing the following construction.

Proof:

Let (ψ, U) be a Morse chart around q and assume that $m \in U - \{q\}$. We may work locally, hence we identify U with $\mathbb{E} = \mathbb{E}^u \oplus \mathbb{E}^s$ having coordinates (x, y) , and by abuse of notation write f and φ for the local representatives $f \circ \psi^{-1}$ and $\psi \circ \varphi_t \circ \psi^{-1}$ respectively. Moreover we let $\psi(q) = 0$ and $f(0) = 0$ hence $f(x, y) = -|x|^2 + |y|^2$ by the Morse lemma, and $\varphi_t(x, y) = (xe^{2t}, ye^{-2t})$ since g is compatible with U .

Let $W_{loc}^u(p)$ denote the local representatives of $W^u(p)$, i.e. $W_{loc}^u(p) \approx U \cap W^u(p)$, and $z_i = (x_i, y_i) \in W_{loc}^u(p) \rightarrow z = (x', 0) \in \mathbb{E}^u$ be the sequence corresponding to $m_i \rightarrow m$. We thus have to show that

$$T_z\mathbb{E}^u \subset T = \lim_{z_i \rightarrow z} T_{z_i}W_{loc}^u(p).$$

Let $(u, 0) \in T_z\mathbb{E}^u$ be any tangent vector. In the sequel we will construct a sequence of tangent vectors in $T_{z_i}W_{loc}^u(p)$ converging to $(u, 0)$ implying that

⁴Note that $(\overline{W^u(a)}, \mathcal{P})$ is an (A)-prestratification if $\dim(M) \leq 2$, by dimensional reasons.

$T_z \mathbb{E}^u \subset T$, thus proving the claim. This is done by induction on the relative index $\mu(p, q) = \lambda_p - \lambda_q$. Hence assume that $\mu(p, q) = 1$.

Let $t_i = 1/2 \ln |y_i|$ and consider the sequence $w_i = \varphi_{t_i}(z_i) = (x_i |y_i|, y_i / |y_i|)$ in $W_{loc}^u(p)$. Since $x_i |y_i| \rightarrow 0$ and $y_i / |y_i| \in \mathbb{S}^s$, we have $w_i \rightarrow w = (0, y')$, $y' \in \mathbb{S}^s$, by transition to a subsequence. Moreover, $w \notin (\overline{W_{loc}^u(p)} - W_{loc}^u(p))$ since $\mu(p, q) = 1$ and $w \in \mathbb{S}^s$, hence $w \in W_{loc}^u(p) \cap \mathbb{E}^s$ and $T_{w_i} W_{loc}^u(p) \rightarrow T_w W_{loc}^u(p)$. It follows that

$$\begin{aligned} \mathbb{E}^u \oplus \mathbb{E}^s &\approx \nu_w(W_{loc}^u(p) \cap \mathbb{E}^s, W_{loc}^u(p)) \oplus T_w(W_{loc}^u(p) \cap \mathbb{E}^s) \oplus \nu_w(W_{loc}^u(p) \cap \mathbb{E}^s, \mathbb{E}^s) \\ &\approx \nu_w(W_{loc}^u(p) \cap \mathbb{E}^s, W_{loc}^u(p)) \oplus \mathbb{E}^s \end{aligned}$$

hence $(u, v) \in T_w W_{loc}^u(p)$ for some $v \in \mathbb{E}^s$. Let (u_i, v_i) denote a sequence with $(u_i, v_i) \in T_{w_i} W_{loc}^u(p)$ and $(u_i, v_i) \rightarrow (u, v)$. Now using the linear isomorphism $D\varphi_{-t_i}(w_i) : T_{w_i} W_{loc}^u(p) \rightarrow T_{z_i} W_{loc}^u(p)$, we have $D\varphi_{-t_i}(w_i)(|y_i|u_i, |y_i|v_i) = (u_i, |y_i|^2 v_i)$ by direct calculations. Hence $(u_i, |y_i|^2 v_i) \rightarrow (u, 0)$ proving the basis step in the induction.

By induction hypothesis assume that the pair $(W^u(p'), W^u(q'))$ is (A)-regular for $\mu(p', q') < i$.

Now consider the pair $(W^u(p), W^u(q))$ with $\mu(p, q) = i$. We then repeat the above argument and arrive at the sequence $w_i = (x_i |y_i|, y_i / |y_i|) \in W_{loc}^u(p) \rightarrow w = (0, y')$ with $y' \in \mathbb{S}^s$. If $w \in W_{loc}^u(p)$ we are done, if not then certainly $w \in W^u(q')$ for some $W^u(q') \subset \overline{W^u(p)} = \bigcup_{p \geq b} W^u(b)$, in particular $w \in W_{loc}^u(q') \cap \mathbb{E}^s$. Therefore

- 1) $\mu(p, q') < i$, hence $(W^u(p), W^u(q'))$ is (A)-regular
- 2) $(u, v) \in T_w W_{loc}^u(q')$

So there is a sequence $(u_i, v_i) \rightarrow (u, v)$ with $(u_i, v_i) \in T_{w_i} W_{loc}^u(p)$, since $(u, v) \in T_w W_{loc}^u(q') \subset \lim_{w_i \rightarrow w} T_{w_i} W_{loc}^u(p)$. It now follows that $(W^u(p), W^u(q))$ is (A)-regular at m by repeating the last part of the above argument. \square

We now show that claim A.3 is all we need if $m \neq q$.

A.4 Claim.

Let $\{m_i\} \subset W^u(p)$ with $m_i \rightarrow m \in W^u(q)$ and φ be the flow corresponding to $-\nabla f$.

- 1) If $T_{m_i} W^u(p) \rightarrow T$ and $t_i \rightarrow t$ then $d\varphi_{t_i}(m_i) T_{m_i} W^u(p) \rightarrow d\varphi_t(m) T$.

2) If $d\varphi_t(m)T_mW^u(q) \subseteq d\varphi_t(m)T$ then $T_mW^u(q) \subseteq T$.

Proof:

ad 1): This is a local problem, hence let U_m be a chart around m and $TU_m \approx U_m \times \mathbb{R}^n$ the local trivialization corresponding to U_m . The above assumption then becomes $(m_i, \mathbb{F}_i) \rightarrow (m, \mathbb{F})$ where $\mathbb{F}_i, \mathbb{F} \in G(n, \lambda_p)$ are the local representatives of $T_{m_i}W^u(p)$ and T , respectively, and $G(n, \lambda_p)$ denotes the Grassmannian of λ_p -dimensional subspaces of \mathbb{R}^n .

Now let U_z be a chart around $z = \varphi_t(m)$ and $TU_z \approx U_z \times \mathbb{R}^n$ the local trivialization. We then have to show that $(z_i, d\varphi_{t_i}(m_i)\mathbb{F}_i) \rightarrow (z, d\varphi_t(m)\mathbb{F})$, where $z_i = \varphi_{t_i}(m_i)$.

Since φ is smooth $z_i = \varphi_{t_i}(m_i) \rightarrow z = \varphi_t(m)$. Moreover, $d\varphi_{t_i}(m_i) \rightarrow d\varphi_t(m)$ in $GL(n)$ since $d\varphi_{t_i}: U_m \rightarrow GL(n)$ for each t_i . Hence $d\varphi_{t_i}(m_i)\mathbb{F}_i \rightarrow d\varphi_t(x)\mathbb{F}$, since the natural action $GL(n) \times G(n, \lambda_p) \rightarrow G(n, \lambda_p)$; $(A, \mathbb{E}) \rightarrow A\mathbb{E}$ is smooth (see e.g. ([Lee03], p.234)).

ad 2): This is clear since $d\varphi_t(m): T_m\mathbf{M} \rightarrow T_z\mathbf{M}$ is a linear isomorphism. \square

We can now prove lemma A.1.

Proof:

The partition \mathcal{P} is a decomposition of $\overline{W^u(a)}$ by claim A.2.

Let $(W^u(p), W^u(q))$ be any pair with $W^u(p), W^u(q) \in \mathcal{P}$ and $W^u(q) \leq W^u(p)$. Assume that $\{m_i\} \subset W^u(p)$ with $m_i \rightarrow m \in W^u(q) - \{q\}$ and $T_{m_i}W^u(p) \rightarrow T$, hence we need to prove that $T_mW^u(q) \subseteq T$.

If m is contained in a Morse chart we may apply claim A.3. If not choose t such that $z = \varphi(t, m) \in W^u(q)$ is in a Morse chart around q . Let $z_i = \varphi_t(m_i) \in W^u(p)$ and apply part one of claim A.4 to conclude that $T_{z_i}W^u(p) = d\varphi_t(m_i)T_{m_i}W^u(p) \rightarrow d\varphi_t(m)T$, and claim A.3 to conclude $d\varphi_t(m)T_mW^u(q) = T_zW^u(q) \subseteq d\varphi_t(m)T$. Hence $T_mW^u(q) \subseteq T$ by part two of claim A.4. \square

A.3 Future work

The above should be seen as the start of a project whose goal is to determine whether or not $(\overline{W^u(a)}, \mathcal{P})$ is a (B)-prestratification (i.e. a Whitney prestratification, see [Mat73] or [Pfl01] for details). Of course this requires that $(W^u(a), \mathcal{P})$ is an (A)-prestratification i.e. one needs to prove the following conjecture.

A.5 Conjecture.

If m_i is a sequence in $W^u(p)$ converging to q and $T_{m_i}W^u(p) \rightarrow T$, then $T_qW^u(q) \subseteq T$.

To this end we prove the following special case.

A.6 Claim.

Let $m \in W(p, q)$. If m_i is a sequence in the orbit of φ_m converging to q and $T_{m_i}W^u(p) \rightarrow T$, then $T_qW^u(q) \subseteq T$.

Proof:

Let V be a direct summand of $T_mW^s(q)$ in T_mM i.e $T_mM = V \oplus T_mW^s(q)$. In [Abb] it is proven that $d\varphi_t(m)V \rightarrow T_qW^u(q)$ for $t \rightarrow \infty$. Now

$$\begin{aligned} T_mM &= \nu_m(W(p, q), W^u(p)) \oplus T_mW(p, q) \oplus \nu_m(W(p, q), W^s(q)) \\ &= \nu_m(W(p, q), W^u(p)) \oplus T_mW^s(q) \end{aligned}$$

and $\nu_m(W(p, q), W^u(p)) \subset T_mW^u(p)$. Hence

$$d\varphi_t(m)\nu_m(W(p, q), W^u(p)) \subset d\varphi_t(m)T_mW^u(p)$$

and therefore $T_qW^u(q) \subseteq T$. □

Bibliography

- [AB95] D. M. Austin and P. J. Braam. Morse-Bott theory and equivariant cohomology. In *The Floer memorial volume*, volume 133 of *Progr. Math.*, pages 123–183. Birkhäuser, Basel, 1995.
- [Abb] Alberto Abbondandolo. The Morse complex for gradient flows on compact manifolds. Unpublished.
- [AM78] Ralph Abraham and Jerrold E. Marsden. *Foundations of mechanics*. Benjamin/Cummings Publishing Co. Inc. Advanced Book Program, Reading, Mass., 1978. Second edition, revised and enlarged, With the assistance of Tudor Rațiu and Richard Cushman.
- [Apo74] Tom M. Apostol. *Mathematical analysis*. Addison-Wesley Publishing Co., Reading, Mass.-London-Don Mills, Ont., second edition, 1974.
- [AR67] Ralph Abraham and Joel Robbin. *Transversal mappings and flows*. An appendix by Al Kelley. W. A. Benjamin, Inc., New York-Amsterdam, 1967.
- [AT04] Luigi Ambrosio and Paolo Tilli. *Topics on analysis in metric spaces*, volume 25 of *Oxford Lecture Series in Mathematics and its Applications*. Oxford University Press, Oxford, 2004.
- [BBI01] Dmitri Burago, Yuri Burago, and Sergei Ivanov. *A course in metric geometry*, volume 33 of *Graduate Studies in Mathematics*. American Mathematical Society, Providence, RI, 2001.
- [BC03] Jean-Francois Barraud and Octav Cornea. Lagrangian intersections and the Serre spectral sequence. To appear in *Annals of Mathematics*, 2003.

- [BC06] Jean-François Barraud and Octav Cornea. Homotopic dynamics in symplectic topology. In *Morse theoretic methods in nonlinear analysis and in symplectic topology*, volume 217 of *NATO Sci. Ser. II Math. Phys. Chem.*, pages 109–148. Springer, Dordrecht, 2006.
- [BH99] Martin R. Bridson and André Haefliger. *Metric spaces of non-positive curvature*, volume 319 of *Grundlehren der Mathematischen Wissenschaften [Fundamental Principles of Mathematical Sciences]*. Springer-Verlag, Berlin, 1999.
- [BH04] Augustin Banyaga and David Hurtubise. *Lectures on Morse homology*, volume 29 of *Kluwer Texts in the Mathematical Sciences*. Kluwer Academic Publishers Group, Dordrecht, 2004.
- [Big93] Norman Biggs. *Algebraic graph theory*. Cambridge Mathematical Library. Cambridge University Press, Cambridge, second edition, 1993.
- [Bor67] Karol Borsuk. *Theory of retracts*. Monografie Matematyczne, Tom 44. Państwowe Wydawnictwo Naukowe, Warsaw, 1967.
- [Bor94] Francis Borceux. *Handbook of categorical algebra. 1*, volume 50 of *Encyclopedia of Mathematics and its Applications*. Cambridge University Press, Cambridge, 1994. Basic category theory.
- [Bou98] Nicolas Bourbaki. *General topology. Chapters 1–4*. Elements of Mathematics (Berlin). Springer-Verlag, Berlin, 1998. Translated from the French, Reprint of the 1989 English translation.
- [Bre93] Glen E. Bredon. *Topology and geometry*, volume 139 of *Graduate Texts in Mathematics*. Springer-Verlag, New York, 1993.
- [Bro72] William Browder. *Surgery on simply-connected manifolds*. Springer-Verlag, New York, 1972. Ergebnisse der Mathematik und ihrer Grenzgebiete, Band 65.
- [BZ92] Jean-Michel Bismut and Weiping Zhang. An extension of a theorem by Cheeger and Müller. *Astérisque*, (205):235, 1992. With an appendix by François Laudenbach.
- [CJS95] Ralph L. Cohen, John D. S. Jones, and Graeme B. Segal. Morse theory and classifying spaces. preprint, December 1995.

- [Coh92] Ralph L. Cohen. Morse theory via moduli spaces. *Mat. Contemp.*, 2:19–66, 1992. Workshop on the Geometry and Topology of Gauge Fields (Campinas, 1991).
- [Con79] Pierre E. Conner. *Differentiable periodic maps*, volume 738 of *Lecture Notes in Mathematics*. Springer, Berlin, second edition, 1979.
- [Dol80] Albrecht Dold. *Lectures on algebraic topology*, volume 200 of *Grundlehren der Mathematischen Wissenschaften [Fundamental Principles of Mathematical Sciences]*. Springer-Verlag, Berlin, second edition, 1980.
- [Dug66] James Dugundji. *Topology*. Allyn and Bacon Inc., Boston, Mass., 1966.
- [Fra79] John M. Franks. Morse-Smale flows and homotopy theory. *Topology*, 18(3):199–215, 1979.
- [Fra82] John M. Franks. *Homology and dynamical systems*, volume 49 of *CBMS Regional Conference Series in Mathematics*. Published for the Conference Board of the Mathematical Sciences, Washington, D.C., 1982.
- [Gre67] W. H. Greub. *Linear algebra*. Third edition. Die Grundlehren der Mathematischen Wissenschaften, Band 97. Springer-Verlag New York, Inc., New York, 1967.
- [GRS03] Ralf Gautschi, Joel W. Robbin, and Dietmar A. Salamon. Heegaard splittings and Morse-Smale flows. *Int. J. Math. Math. Sci.*, (56):3539–3572, 2003.
- [GT87] Jonathan L. Gross and Thomas W. Tucker. *Topological graph theory*. Wiley-Interscience Series in Discrete Mathematics and Optimization. John Wiley & Sons Inc., New York, 1987. , A Wiley-Interscience Publication.
- [Hat02] Allen Hatcher. *Algebraic topology*. Cambridge University Press, Cambridge, 2002.
- [Hir94] Morris W. Hirsch. *Differential topology*, volume 33 of *Graduate Texts in Mathematics*. Springer-Verlag, New York, 1994. Corrected reprint of the 1976 original.

- [HJ85] Roger A. Horn and Charles R. Johnson. *Matrix analysis*. Cambridge University Press, Cambridge, 1985.
- [Hur00] David E. Hurtubise. The flow category of the action functional on $\mathcal{L}G_{N,N+K}(\mathbb{C})$. *Illinois J. Math.*, 44(1):33–50, 2000.
- [Hus75] Dale Husemoller. *Fibre bundles*. Springer-Verlag, New York, second edition, 1975. Graduate Texts in Mathematics, No. 20.
- [Hut02] Michael Hutchings. Lecture notes on Morse homology. Lecture notes, December 15, 2002.
- [Irw01] M. C. Irwin. *Smooth dynamical systems*, volume 17 of *Advanced Series in Nonlinear Dynamics*. World Scientific Publishing Co. Inc., River Edge, NJ, 2001. Reprint of the 1980 original, With a foreword by R. S. MacKay.
- [Jac52] James R. Jackson. Some theorems concerning absolute neighborhood retracts. *Pacific J. Math.*, 2:185–189, 1952.
- [Jos98] Jürgen Jost. *Riemannian geometry and geometric analysis*. Universitext. Springer-Verlag, Berlin, second edition, 1998.
- [Jos02] Jürgen Jost. *Riemannian geometry and geometric analysis*. Universitext. Springer-Verlag, Berlin, third edition, 2002.
- [Kah80] Donald W. Kahn. *Introduction to global analysis*, volume 91 of *Pure and Applied Mathematics*. Academic Press Inc. [Harcourt Brace Jovanovich Publishers], New York, 1980.
- [Kli95] Wilhelm P. A. Klingenberg. *Riemannian geometry*, volume 1 of *de Gruyter Studies in Mathematics*. Walter de Gruyter & Co., Berlin, second edition, 1995.
- [Kos93] Antoni A. Kosinski. *Differential manifolds*, volume 138 of *Pure and Applied Mathematics*. Academic Press Inc., Boston, MA, 1993.
- [Kur35] C. Kuratowski. Sur les espaces localement connexes et péaniens en dimension n . *Found. Math.*, 24:269–287, 1935.
- [Lan99] Serge Lang. *Fundamentals of differential geometry*, volume 191 of *Graduate Texts in Mathematics*. Springer-Verlag, New York, 1999.

- [Lat94] François Latour. Existence de 1-formes fermées non singulières dans une classe de cohomologie de de Rham. *Inst. Hautes Études Sci. Publ. Math.*, (80):135–194 (1995), 1994.
- [Lau04] François Laudenbach. Symplectic geometry and Floer homology. In *Symplectic geometry and Floer homology. A survey of the Floer homology for manifolds with contact type boundary or symplectic homology*, volume 7 of *Ensaïos Mat.*, pages 1–50. Soc. Brasil. Mat., Rio de Janeiro, 2004.
- [Lee00] John M. Lee. *Introduction to topological manifolds*, volume 202 of *Graduate Texts in Mathematics*. Springer-Verlag, New York, 2000.
- [Lee03] John M. Lee. *Introduction to smooth manifolds*, volume 218 of *Graduate Texts in Mathematics*. Springer-Verlag, New York, 2003.
- [Let03] John-Josef Leth. Critical Points, Classifying Spaces and Generic Morse Functions. Master’s thesis, Aalborg University, Department of Mathematical Sciences, 2003.
- [Lu04] Guangcun Lu. An explicit isomorphism between Floer homology and quantum homology. *Pacific J. Math.*, 213(2):319–363, 2004.
- [Mat73] John N. Mather. Stratifications and mappings. In *Dynamical systems (Proc. Sympos., Univ. Bahia, Salvador, 1971)*, pages 195–232. Academic Press, New York, 1973.
- [Mat02] Yukio Matsumoto. *An introduction to Morse theory*, volume 208 of *Translations of Mathematical Monographs*. American Mathematical Society, Providence, RI, 2002. Translated from the 1997 Japanese original by Kiki Hudson and Masahico Saito, Iwanami Series in Modern Mathematics.
- [Mey68] K. R. Meyer. Energy functions for Morse Smale systems. *Amer. J. Math.*, 90:1031–1040, 1968.
- [Mil59] John Milnor. On spaces having the homotopy type of CW-complex. *Trans. Amer. Math. Soc.*, 90:272–280, 1959.
- [Mil63] J. Milnor. *Morse theory*. Based on lecture notes by M. Spivak and R. Wells. Annals of Mathematics Studies, No. 51. Princeton University Press, Princeton, N.J., 1963.

- [Mil65] John Milnor. *Lectures on the h -cobordism theorem*. Notes by L. Siebenmann and J. Sondow. Princeton University Press, Princeton, N.J., 1965.
- [ML98] Saunders Mac Lane. *Categories for the working mathematician*, volume 5 of *Graduate Texts in Mathematics*. Springer-Verlag, New York, second edition, 1998.
- [MS98] Dusa McDuff and Dietmar Salamon. *Introduction to symplectic topology*. Oxford Mathematical Monographs. The Clarendon Press Oxford University Press, New York, second edition, 1998.
- [Pal68] J. Palis. On Morse-Smale dynamical systems. *Topology*, 8:385–404, 1968.
- [PdM82] Jacob Palis, Jr. and Welington de Melo. *Geometric theory of dynamical systems*. Springer-Verlag, New York, 1982. An introduction, Translated from the Portuguese by A. K. Manning.
- [Pfl01] Markus J. Pflaum. *Analytic and geometric study of stratified spaces*, volume 1768 of *Lecture Notes in Mathematics*. Springer-Verlag, Berlin, 2001.
- [PS70] J. Palis and S. Smale. Structural stability theorems. In *Global Analysis (Proc. Sympos. Pure Math., Vol. XIV, Berkeley, Calif., 1968)*, pages 223–231. Amer. Math. Soc., Providence, R.I., 1970.
- [RF06] Martin Raussen and Ulrich Fahrenberg. Reparametrizations of continuous paths. Research Report R-2006-22, Department of Mathematical Sciences, Aalborg University, Fredrik Bajers Vej 7G, 9220 Aalborg Øst, Denmark, 2006.
- [Sal90] Dietmar Salamon. Morse theory, the Conley index and Floer homology. *Bull. London Math. Soc.*, 22(2):113–140, 1990.
- [Sch93] Matthias Schwarz. *Morse homology*, volume 111 of *Progress in Mathematics*. Birkhäuser Verlag, Basel, 1993.
- [Sch99] Matthias Schwarz. Equivalences for Morse homology. In *Geometry and topology in dynamics (Winston-Salem, NC, 1998/San Antonio, TX, 1999)*, volume 246 of *Contemp. Math.*, pages 197–216. Amer. Math. Soc., Providence, RI, 1999.

-
- [Shu87] Michael Shub. *Global stability of dynamical systems*. Springer-Verlag, New York, 1987. With the collaboration of Albert Fathi and Rémi Langevin, Translated from the French by Joseph Christy.
- [Sma61] Stephen Smale. On gradient dynamical systems. *Ann. of Math. (2)*, 74:199–206, 1961.
- [Spa81] Edwin H. Spanier. *Algebraic topology*. Springer-Verlag, New York, 1981. Corrected reprint.
- [Web06] Joa Weber. The Morse-Witten complex via dynamical systems. *Expo. Math.*, 24(2):127–159, 2006.
- [Wis05] Rafal Wisniewski. *Flow lines under perturbations within section cones*. PhD thesis, Aalborg University, Department of Mathematical Sciences, 2005.