



**AALBORG UNIVERSITY**  
DENMARK

**Aalborg Universitet**

## **Didactical Research in Engineering**

*Theory and Practice*

Abou-Hayt, Imad

*DOI (link to publication from Publisher):*  
[10.54337/aau450852510](https://doi.org/10.54337/aau450852510)

*Publication date:*  
2021

*Document Version*  
Publisher's PDF, also known as Version of record

[Link to publication from Aalborg University](#)

*Citation for published version (APA):*  
Abou-Hayt, I. (2021). *Didactical Research in Engineering: Theory and Practice*. Aalborg Universitetsforlag.  
<https://doi.org/10.54337/aau450852510>

### **General rights**

Copyright and moral rights for the publications made accessible in the public portal are retained by the authors and/or other copyright owners and it is a condition of accessing publications that users recognise and abide by the legal requirements associated with these rights.

- Users may download and print one copy of any publication from the public portal for the purpose of private study or research.
- You may not further distribute the material or use it for any profit-making activity or commercial gain
- You may freely distribute the URL identifying the publication in the public portal -

### **Take down policy**

If you believe that this document breaches copyright please contact us at [vbn@aub.aau.dk](mailto:vbn@aub.aau.dk) providing details, and we will remove access to the work immediately and investigate your claim.



# **DIDACTICAL RESEARCH IN ENGINEERING: THEORY AND PRACTICE**

**BY  
IMAD ABOU-HAYT**

DISSERTATION SUBMITTED 2021



**AALBORG UNIVERSITY**  
DENMARK





---

---

# Didactical Research in Engineering: Theory and Practice

---

---

Ph.D. Dissertation  
Imad Abou-Hayt

Dissertation submitted February 15, 2021

Dissertation submitted: February 15, 2021

PhD supervisor: Prof. Bettina Dahl Søndergaard  
University of Bergen, Norway and  
Aalborg University, Denmark

Assistant PhD supervisor: Assoc. Prof. Camilla Østerberg Rump  
University of Copenhagen, Denmark

PhD committee: Associate Professor Andrés Felipe Valderrama Pineda (chair)  
Aalborg University  
Professor Dr. Rolf Biehler  
Pedeborg University  
Associate Professor Kristina Edström  
KTH Royal Institute of Technology

PhD Series: Technical Faculty of IT and Design, Aalborg University

Department: Department of Planning

ISSN (online): 2446-1628  
ISBN (online): 978-87-7210-897-1

Published by:  
Aalborg University Press  
Kroghstræde 3  
DK – 9220 Aalborg Ø  
Phone: +45 99407140  
aauf@forlag.aau.dk  
forlag.aau.dk

© Copyright: Imad Abou-Hayt

Printed in Denmark by Rosendahls, 2021

# Abstract

The debate between educational models that "transmit knowledge" and others in which "knowledge is constructed" currently seems to tend toward the later. Many theories of education assume that learning mathematics and engineering should be based on constructivist methods, where students inquire authentic situations, and assign a facilitator role to the teacher. In a contrasting view, other theories advocate for a more central role to the teacher through explicit transmission of knowledge and the students' active reception. However, I believe that this debate is hiding the following facts:

- The teacher is a decision maker, influenced by important factors such as time constraints, knowledge, beliefs and emotions.
- The students differ in skills and knowledge, and most of them need a strong guidance to learn, even if some students with high skills and knowledge can learn advanced ideas with little or no help.
- The type of help needed depends on the nature of knowledge to be built or transmitted in a usually heterogeneous class.

In this thesis, I argue that improving the students' engineering and mathematics learning requires adopting an intermediate position between these two extreme models, in recognizing the complex dialectic between the students' inquiry and the teacher's delivery of engineering and mathematical knowledge. I base my position on an experience-based synthesis of constructivist pedagogical models and teacher-led learning, in such a way that I could adjust the teaching schedule to adapt to the learning progress of the students. My model is inspired by both the mathematical modeling process and the engineering design process. Being iterative in nature, the aim of both processes is to find the optimal product that meets given constraints and specifications. Similarly, my approach attempts to incorporate the fact that teaching a university course is often carried out in cyclic processes, the purpose of which is to improve the final product, namely student learning.





# Resumé

Debatten mellem didaktiske teorier, der "formidler viden" og andre, hvor "viden er konstrueret", synes i øjeblikket at hælde til sidstnævnte. Mange undervisningsteorier antager, at indlæring af matematik og ingeniørfag bør være baseret på konstruktivistiske metoder, hvor de studerende undersøger realistiske situationer og tildeler læreren en facilitatorrolle. I en modsat opfattelse, går andre teorier ind for en mere central rolle for læreren, der indebærer eksplicit formidling af viden og de studerendes aktive modtagelse. Jeg mener imidlertid, at denne debat skjuler følgende fakta:

- Læreren er en beslutningstager, der er påvirket af vigtige faktorer som tidsbegrænsninger, viden, tro og følelser.
- De studerende er forskellige i færdigheder og viden, og de fleste af dem har brug for en stærk vejledning til at lære, selvom nogle studerende med høje færdigheder og viden kan lære avancerede ideer med lidt eller ingen hjælp.
- Den nødvendige hjælp er afhængig af arten af den viden, der skal bygges eller overføres i en klasse, der normalt er heterogen.

I denne afhandling argumenterer jeg for, at forbedring af ingeniørvidenskabs- og matematikundervisning kræver, at der indtages en mellemstilling mellem disse to ekstreme modeller, ved at anerkende den komplekse dialektik mellem studerendes indlæring og lærerens levering af ingeniørvidenskab og matematisk viden. Jeg baserer min holdning på en praksisbaseret syntese af konstruktivistiske pædagogiske modeller og lærerstyret undervisning på en sådan måde, at jeg kunne justere undervisningsplanen til at tilpasse sig de studerendes læringsfremskridt. Min model er inspireret af både den matematiske modelleringsproces og den ingeniørmæssige designproces. Givet at begge processer er iterative, er formålet at finde det optimale produkt, der opfylder givne begrænsninger og specifikationer. Min tilgang til didaktik inddrager derfor det faktum, at undervisning i et universitetskursus ofte udføres i cyk-

liske processer, hvis formål er at forbedre det endelige produkt, nemlig de studerendes læring.

# Contents

<b>Abstract</b>	<b>iii</b>
<b>Resumé</b>	<b>v</b>
<b>Preface</b>	<b>xiii</b>
<b>I Didactical Situations in Engineering Education</b>	<b>1</b>
	<b>3</b>
1 Introduction . . . . .	3
1.1 Aim of the Thesis . . . . .	5
1.2 The Structure of the Thesis . . . . .	7
2 Theoretical Perspectives . . . . .	8
2.1 Problem-Based Learning . . . . .	8
2.2 Inquiry-Based Learning and Constructivism . . . . .	10
2.3 Variation Theory . . . . .	14
2.4 Theory of Didactical Situations . . . . .	14
2.5 The Anthropological Theory of Didactics . . . . .	18

2.6	Didactical Engineering . . . . .	19
2.7	Design-Based Research . . . . .	20
2.8	Action Research . . . . .	23
3	Mathematical Modeling . . . . .	24
3.1	Introduction . . . . .	24
3.2	The Modeling Cycle . . . . .	25
3.3	Modeling Competences . . . . .	27
3.4	Challenges in Teaching and Learning Mathematical Modeling . . . . .	28
3.5	Merits of Mathematical Modeling . . . . .	29
3.6	Some Reflections on Mathematical Modeling . . . . .	31
4	Research Methodology . . . . .	32
5	Brousseau in Action: Using TDS in Engineering . . . . .	38
5.1	Presentation of the Case Study . . . . .	40
5.2	The Devolution Phase . . . . .	41
5.3	The Action Phase . . . . .	44
5.4	The Formulation Phase . . . . .	47
5.5	The Validation Phase . . . . .	48
5.6	The Institutionalization Phase . . . . .	49
6	Some Issues of Applying TDS in the Course . . . . .	50
7	Mathematical Modeling and TDS . . . . .	53
8	Mathematical Modeling and other Theoretical Perspectives . . . . .	55
8.1	Realistic Mathematics Education . . . . .	55
8.2	The Anthropological Theory of Didactics Revisited . . . . .	57

9	The Didactical Modeling Cycle . . . . .	59
10	Conclusion . . . . .	64
	References . . . . .	67
 <b>II Papers</b>		<b>75</b>
 <b>A A Problem-Based Approach to Teaching a Course in Engineering Mechanics</b>		<b>77</b>
1	What is Problem-Based Learning? . . . . .	81
2	The Course Project . . . . .	83
3	A Teaching Situation in Statics: An Example . . . . .	85
4	Examples of Students Solutions . . . . .	88
5	Course Evaluation . . . . .	89
6	Discussion and Conclusion . . . . .	92
	References . . . . .	93
 <b>B Teaching the Limits of Functions Using the Theory of Didactical Situations and Problem-Based Learning</b>		<b>97</b>
1	Introduction . . . . .	101
2	Why Limits are Important? . . . . .	102
3	On Problem-Based Learning (PBL) . . . . .	102
4	On the Theory of Didactic Situations (TDS) . . . . .	103
5	Research Questions . . . . .	103
6	A Problem-Based Approach . . . . .	104
6.1	Sources of Difficulties in the Teaching of the Concept of Limit . . . . .	104

6.2	Teaching Situations Leading to the Concept of Limit . . .	105
7	Concluding Remarks and Discussion . . . . .	111
8	Future research perspectives . . . . .	112
	References . . . . .	113
<b>C</b>	<b>Exploring Students Conceptions of Vectors: A Phenomenographic Study</b>	<b>115</b>
1	Introduction . . . . .	119
2	On Phenomenography and Variation Theory . . . . .	120
3	Study Methodology . . . . .	122
4	Lesson Design . . . . .	123
5	Results of the Study . . . . .	125
6	Concluding Remarks and Discussion . . . . .	128
7	Future Research Perspectives . . . . .	129
	References . . . . .	129
<b>D</b>	<b>Integrating the Methods of Mathematical Modeling and Engineer- ing Design in Projects</b>	<b>133</b>
1	Introduction . . . . .	137
2	The Processes of Mathematical Modeling and Engineering Design	139
2.1	Mathematical Modeling as a Design Process . . . . .	139
2.2	Mathematics in an Engineering Context: An Example . . . . .	141
3	Mathematical Modeling in Action . . . . .	143
3.1	Example 1: Model of a Lego Van and a Caravan . . . . .	143
3.2	Student Simulation of the Model . . . . .	144

3.3	Example 2: The Connection between Mathematical Modeling and Engineering Design . . . . .	145
4	Discussion and Conclusion . . . . .	146
	References . . . . .	147
<b>E</b>	<b>Inquiry-Based Teaching in Engineering: The Case of "Transfer Functions"</b>	<b>149</b>
1	Introduction . . . . .	153
2	The Laplace Transform . . . . .	154
3	A Brief History of the Laplace Transform . . . . .	156
4	The Didactical Challenges in Teaching Transfer Functions . . . . .	157
5	Didactical Model: Inquiry-Based Learning . . . . .	161
6	Implementation and Analysis of the Didactical Model . . . . .	162
7	Evaluation of the Didactical Model . . . . .	166
8	Discussion and Conclusion . . . . .	168
9	Epilogue . . . . .	170
	References . . . . .	170





# Preface

This thesis is the culmination of years of teaching and learning to teach at Aalborg University, Denmark. I was attracted to the vast field of didactics when following some pedagogical seminars and courses in the early years of my teaching career. During those seminars, every one was talking about learning-to-teach strategies and debating the merits of one educational theory vs. another.

Years of teaching have passed. I never stopped thinking about didactics and reflecting on my own teaching. Learning is of course what my students do at the university. But not only the students are there to learn; I am too. I then wondered if learning-to-teach methods can be supplemented by teaching-to-learn ones, by collecting, analyzing and evaluating information about what goes on in my classroom. Using this new information, I can identify and explore my own practices and underlying beliefs, which may lead to changes and improvements in my teaching.

And, of course, the teaching-to-learn process is a cycle that should be repeated again and again: It is a process that never stops, even if I am an old hand that has been on the job forever.

My own teaching in mathematical modeling led me to think about the whole teaching process as a didactical modeling cycle that continuously strives to improve teaching and learning.

Part I of this thesis elaborates on this concept and the associated educational theories. It presents the author's own experience in applying major didactical approaches in engineering science and mathematics courses at Aalborg University in Copenhagen. In a nutshell, the didactical modeling cycle is an inductive, interactive and adaptive teaching methodology that could enhance the students' learning motivation in line with the university's mission of providing high quality education. It is original, unpublished and independent

work by the author.

Part II of the thesis consists of five papers of the author. They played a crucial role in shaping my own thoughts about the didactical modeling cycle.

As such, this thesis is not a monograph but a collection of five papers and a "*Kappe*" (Danish for "cape") binding the five papers together and putting them into perspective.

This thesis has been written to fulfill the the requirements for the degree of Doctor of Philosophy at the Department of Planning at Aalborg University. The research was difficult, but conducting extensive investigation allowed me to answer the questions that I identified. Fortunately, my supervisors were always available and willing to answer my queries.

I myself prepared the non-referenced figures and the pictures in the thesis.

I would like to thank my supervisors, Bettina Dahl Søndergaard and Camilla Østerberg Rump, for their excellent guidance and support during this process. Special thanks go to associate professor Aida Guerra, at Aalborg Center for PBL in Engineering Science and Sustainability, for her valuable comments during the preparation of this thesis.

I also wish to thank all of the respondents, without whose cooperation I would not have been able to conduct this dissertation. I also benefited from debating issues with my colleagues and students.

I hope you enjoy your reading.

Imad Abou-Hayt

Aalborg University, February 15, 2021

## **Part I**

# **Didactical Situations in Engineering Education**



# 1 Introduction

The main goal of research in education is to study the factors affecting the teaching and learning of a subject and to develop models to improve teaching and learning. Presumably, researchers in education are engaged in creating didactical theories which, when put under "empirical investigations", should support the cooperation between the researchers and practitioners of the research.

In my understanding, the purpose of a didactical theory is to investigate phenomena in education and to provide the tools to design, understand, describe and explain teaching and learning. In other words, a didactical theory should unify and develop knowledge, which arises from the practice of solving educational problems. In that sense, educational theories are analogous to mathematical models: Both aim to assist us in framing the practices arising from questions about the world. More specifically, they should help us to identify, understand and describe some parts of the world, be it educational, physical or social. In this thesis, I will use the terms "didactical theory" and "didactical model" interchangeably.

My background as an engineer and an educator in engineering science led me to regard education research in engineering as applied science or design science, which studies the concrete action of the teaching by carrying out a mediation between didactics, mathematics and engineering.

In other words, the work of education researchers can be similar to that of engineers and designers, since research draws on multiple practical and disciplinary perspectives and is driven by the need to solve real problems as well as by the need to develop relevant theories:

"Our view of design in education research is based, in part, on the similarities and parallels to be drawn between education and engineering as fields which simultaneously seek to advance knowledge, impact human problems, and

develop products for use in practice." [67, p. 526]

This conforms to the fact that engineers, in their attempt to solve a practical problem for society or design a new product, use codes and standards, in addition to standard scientific theories. In fact, engineering sciences are *more than* just using and applying the results and methods of natural sciences: They produce their own knowledge and are governed by "local" laws and methods that are independent of the natural sciences [64].

To extend the analogy between an engineer and an educator, I will go even further: I regard both education research in engineering and teaching as two *complementary* processes that can be described by what I call a didactical modeling cycle, that continuously strives to improve both the instructor's teaching and the students' learning, similar to the product modeling cycle in engineering design, that is used to continuously improve the final engineering product. The experiences gained in the classroom can be regarded as a new data input to refine the didactical model, used by the instructor, and may initiate a new cycle of educational research.

Thus, my didactical modeling cycle can have strong implications to research-based theories themselves and can lead researchers in education to reorganize the quality criteria for their research such as relevance to the instructors in engineering courses. Moreover, it can contribute in narrowing the gap between educational theories and the actual practices of instructors, since it evolves in a dialectic process between the two poles.

My teaching is conducted in an adaptive manner in the sense that I monitor both my teaching and the students' learning to adjust instruction as necessary: The more competent a student becomes, the less guidance I need to provide.

Students learn in different ways. The learning process of a student is a dynamic process, that is affected by a range of factors, including prior knowledge, ability and motivation. Accordingly, I also adjust the teaching focus, based on the needs of the individual student as well as the feedback generated from course evaluations. In addition, the areas in which students need help should be clearly identified so that I can modify the teaching focus of the next class to adapt to the students' progress.

Inspired by the mathematical modeling process and the engineering design process, I thus came to the conclusion that the modeling approach could somehow be translated to a didactical context and could be transferred to my own teaching in mathematics and engineering science in a meaningful way.

Learning at schools and universities is drastically changing in terms of what

is learned, contexts in which learning takes place, and who is learning. Education research ought to reflect these changes in its agenda and propose adequate solutions. First of all, curriculum designers and teachers should become aware of the diversity of the learners' backgrounds. This is not a trivial issue. In the practical field, it could be the case that some teachers apply instructional design models that were developed in the seventies and eighties of the last century. These models do not always meet present requirements anymore. Moreover, instructional designers must develop a research agenda that enables the development of instructional design models and guidelines that fit the new reality in the classroom.

I consider the use of real-life problems as a driving force for educating engineers. These problems range from well-structured to ill-structured ones, and different types of learning tasks must be designed that address the different cognitive and meta-cognitive processes of the students. These different types of tasks would require different instructional arrangements in terms of sequencing, scaffolding and information support. Thus, high-quality instructional design research is required and should focus on the instructional methods that are effective, efficient and appealing for teaching complex skills in a highly flexible fashion, and also on the learners' individual needs and preferences.

My teaching method gives the instructor a leading role in the classroom and acknowledges teachers as decision makers, influenced by important factors that the research should not neglect, such as the teachers' knowledge, beliefs and emotions. It is an experience-based model that is not directed towards an abstract knowledge of some aspect of teaching; it is directed towards changing something in teaching; it has an innovative character based on a practical framework that leads us to reorganize the quality criteria for research such as usability and importance.

It may be the case that there is no single didactical model that "fits all" in a typically heterogeneous class, but rather a *combination* of various models. The students themselves can more often be characterized as lifelong learners and have different expectations and perceptions of learning. Using the same didactical model every time a course runs can be problematic, as this entails a homogeneity among the learners that simply may not exist.

## **1.1 Aim of the Thesis**

The general aim of this thesis is a presentation of the experiences that both the students and I have of learning, teaching and working with various

educational theories in mathematics and engineering education research.

The thesis is the culmination of my own experiences in applying major didactical theories in engineering science and mathematics courses at Aalborg University. In my teaching, I applied Problem-Based Learning (PBL), Inquiry-Based Learning (IBL), Variation Theory (VT), Theory of Didactical Situations (TDS) as well as interactive lecturing through worked examples, as documented in my papers. These approaches are the theoretical framework of my work and are discussed in the following section.

The main research questions of this thesis are:

1. To what extent can major didactical theories be transferred to engineering and design-oriented study programs at the university?
2. How can didactical theories be combined to produce locally optimized didactical situations in engineering?

In investigating these research questions, I used both quantitative and qualitative research methods, including pretest-posttest designs, group reports, student interviews and group observations.

The purpose of my research is not to give any transferable or generalizable description to be a representative for the entire population of the application of didactical theories in engineering education, but rather to use a small sample of applications of major didactical theories to thoroughly investigate how these theories work in an engineering context and to record the issues that could be raised. My intention is to produce local didactical laws that are valid in a restricted part of the educational landscape, just like when engineers devise empirical laws and formulas, that are confined to certain products, systems or limited parts of the reality. These empirical laws does not contradict the universal laws of nature or the standard models of systems that the engineers became acquainted with in their studies, but can be regarded as useful extensions for the benefits of society. The same can be said about the local didactical theories used to optimize teaching and learning for the benefits of instructors and students.

In the process of answering the research questions, I came to the conclusion that a hybrid teaching methodology, involving teacher-led discussions, worked examples and elements of the above-mentioned didactical approaches could be the response to the challenge of designing teaching situations in a usually heterogeneous class, given the time limitations and curriculum of the courses taught.



Being a "product" of the didactical modeling cycle, a locally optimized didactical situation is in fact a complex dialectical process between the roles of teacher as instructor and facilitator, and the students' roles as constructors of knowledge and receivers of information that makes sense for them.

In a nutshell, an inductive, interactive and adaptive teaching methodology could enhance the students' learning motivation in line with the university's mission of providing high quality education.

## 1.2 The Structure of the Thesis

This thesis consists of two parts: Part I includes a discussion of some theoretical perspectives in education research in order to clarify the notions and the terminology used in the papers, while Part II includes the five papers themselves:

**Paper A:** A Problem-Based Approach to Teaching a Course in Engineering Mechanics

**Paper B:** Teaching the Limits of Functions Using the Theory of Didactical Situations and Problem-Based Learning

**Paper C:** Exploring Students' Conceptions of Vectors: A Phenomenographic Study

**Paper D:** Integrating the Methods of Mathematical Modeling and Engineering Design in Projects

**Paper E:** Inquiry-Based Teaching in Engineering: The Case of "Transfer Functions"

Part I also includes a thorough implementation of a major didactical theory in an engineering course, as well a description of the problems and challenges that arose in the process.

In addition, Part I involves a detailed elaboration on mathematical modeling and its connection with the theoretical perspectives mentioned in the thesis.

In fact, mathematical modeling can be regarded as the "red thread" that "joins the five papers together". Moreover, mathematical modeling inspired me to design a didactical "meta-model", that I call "the didactical modeling cycle". On the one hand, this meta-model could include modified versions of

didactical theories, and on the other hand, takes the constraints imposed on the instructor and the students' needs into account.

The results and implications of the thesis are discussed in the final section of Part I.

## 2 Theoretical Perspectives

Many different theoretical perspectives characterize engineering and mathematics education research. In general, a theoretical perspective can be understood as a lens through which we view a part of reality that informs the questions we ask and the kinds of answers we arrive at as a result. In the context of this thesis, a theoretical perspective can denote either a didactical model, such as the Theory of Didactical Situations, or the design and experimentation of teaching sessions, such as Didactical Engineering.

The diversity of theoretical perspectives may represent a challenge for the educational community for several reasons, including problems of communication and problems of integration of empirical results [14]. Learning to cope with such diversity through networking may be a partial answer to this challenge:

"If we can develop and maintain a certain degree of networking between some of the advocates of the different theoretical stances that are currently evident within mathematics education, this will constitute an important step on the path towards establishing mathematics education as a scientific discipline." [11, p. 1242]

A variety of approaches may be justified to use, when the didactical phenomenon at stake seems to be complicated with a multitude of aspects, such as personal, social and epistemological ones.

In this section, I give short introductions to the major theoretical perspectives that I used in my own teaching and in my papers.

### 2.1 Problem-Based Learning

Problem-Based Learning (PBL) can be defined as learning by problem solving, where the self-guided learning process of the students is in focus. It begins when students are confronted with an authentic problem and then work in

groups to try to develop a viable solution to the problem. "It is crucial that the problem serves as the basis for the learning process, because this determines the direction of the learning process and places emphasis on the formulation of a question rather than on the answer" [43, p. 658].

Moreover, group work is a fundamental activity in PBL. The students learn by relating their knowledge to a given problem which the teacher prepares. Through dialogue and discussions, the students in the groups try to solve the problem by using their previous knowledge and the new knowledge they gained through their courses. In PBL, it is important to pose problems that make sense to the students and to let them define their knowledge gaps by themselves, under the guidance of the teacher/facilitator.

One of the main goals of PBL is to help the students develop real-world skills. According to [95], PBL is "an educational technique which tries to solve complex problems that the students would face in the future by asking them to cope with complicated and ill-structured difficulties of the real world" (p. 175).

A related learning approach is Project-Based Learning (PrBL): Working with projects, PrBL is about the product, while PBL is about the process. The projects are generally defined by a university department, while PBL is personal and student-centered, where the emphasis is on the learning path rather than on a specific goal to achieve. In both PBL and PrBL, the central theoretical learning principles concern three dimensions: the problem, the content and the team.

The implementation of PBL in engineering programs has been reported by several researchers [109], although the practice is still far from being widespread world-wide. At Aalborg University, project-based engineering programs started with the foundation of the university in 1974. These programs include problem-based project work as a central and recurrent element.

In order to ensure that the students become acquainted with a wide range of theories and methods which they can use in their project work, all engineering programs at Aalborg University involve basic and advanced courses in mathematics, physics and computer science, which are mostly still delivered in a traditional lecture-based format.

The first year of all engineering programs includes an introduction to PBL as well as methods of project and group work that the students will need for the rest of their study programs.

Project-based instruction at Aalborg is strongly driven by PBL, and the projects

assigned to the student groups are often practical industry problems, that are renewed each year. The so-named "Aalborg model of PBL" is a combination of a problem-based and a project-organized approach and spans across all faculties of the university. It supports the use of cooperative learning and involves student groups working together on projects, that are based on authentic and real-life problems.

In PBL, teachers act as facilitators during the group work, by engaging in group discussions, observing the work of the students and listening to them. In this way, the teachers get information on whether some major misconceptions are formed, or if a student group does not function properly. In addition, teachers should make sure that the students have access to many different sources of information such as lecture notes, seminars, instructional videos, libraries, etc.

In Problem-Based learning (PBL), the problem formulation is crucial. The problems combine elements from all topics in the course in contrast with textbooks, where only one topic at a time is usually dealt with.

In a PBL-implemented course, supportive lectures and other activities should be prepared by the teacher to provide the students with information to include, when they working on the problems. When one problem is solved, another one is introduced, building on the knowledge gained from the first problem to ensure the progression of knowledge.

This is what I actually did in Paper A: "A Problem-Based Approach to Teaching a Course in Engineering Mechanics" of this thesis, where PBL was applied in an introductory engineering mechanics course, through a series of real-life problems. As far as I know, this is the first implementation of PBL in a course at Aalborg University, where most courses are still taught in a traditional way.

PBL was also implemented in the mathematical topic "Theory of Limits" in Paper B: "Teaching the Limits of Functions Using the Theory of Didactical Situations and Problem-Based Learning".

## **2.2 Inquiry-Based Learning and Constructivism**

Inquiry-based learning (IBL) is a family of approaches to learning that emphasize the students' role in the learning process, by triggering curiosity about a subject and by allowing them to build knowledge through exploration, experience and discussion. In IBL, students are presented with problems to be solved, questions to be answered or observations to be explained.

IBL requires students to engage in experimenting, hypothesizing about possible solutions, communicating hypotheses and possible solution strategies.

In contrast to lecture-based teaching, where the teacher tells the students what they need to know, students are encouraged to explore the material by themselves, ask questions and cooperate to share ideas. And instead of memorizing facts and material, students are given the opportunity of "learning by doing". In fact, the same can be said about problem-based learning, project-based learning and case-based learning.

"One of the main roles for IBL instructors is to manage class discussions, ensuring that discussions are fruitful. The skills required to do this are essential and are distinct from lecturing skills." [47, p. 572]

In IBL, a variety of approaches to learning are used, such as small-group discussions, interactive lecturing and guided learning. For example, a structured form of IBL could be used in the first year of a study program and then shifting towards more self-directed learning as the curriculum progresses.

All these approaches belong to the category of inductive teaching, where the instructor must design teaching situations that *induce* the students to construct their own knowledge and, when necessary, adjust their previous misconceptions and beliefs in light of the evidence provided by their new experiences.

In IBL, a lesson can start by

- asking questions about specific observations,
- presenting case studies or problems for the students to solve, or
- guiding the students to discover a theory, after the need to know it has been established.

Thus, IBL can be considered as a category of inductive teaching methods, that includes problem-based learning, project-based learning and case-based learning.

Inquiry-based learning (IBL) has its roots in constructivism, which posits that individuals actively construct their own knowledge about the world in order to make sense of their own experiences. Proponents of constructivism (e.g., [91, 102]) maintain that learning occurs through social interaction and instruction should support the use of collaborative learning by allowing the students to work together in groups.

In spite of the fact that constructivism is often associated with pedagogical

approaches that promote active learning such as IBL and PBL, it is *not* a theory of *teaching*, but rather a philosophical framework describing how learning happens, regardless of whether learners are using their experiences to understand a lecture or following the instructions for building a model ship. In both cases, constructivism suggests that learners construct knowledge out of their experiences.

Thus, constructivism is consistent with extensive scaffolding and guidance and it does not necessarily entail minimally-guided instruction in the classroom, an approach that I usually do not use in my own teaching. I even claim that constructivism is compatible with a spectrum of guidance that starts with *worked examples*, where the instructor plays a central role, and gradually ends with less and less guidance. Worked examples are provided to the students in order to allow them to narrow down the knowledge gaps they might have, and to let them *construct* new knowledge about problem solving that can be used in other parts of their study.

According to constructivism [18], teaching should start with content that is familiar to the students so that they can relate it to their existing knowledge. The students should be guided by their curiosity when learning, instead of being led by a large amount of instruction. An instructor should present a new material with an eye on its real-world context in a way that changes the students cognitive models, and thus allows them to reconstruct new knowledge.

Even though constructivism is not a specific pedagogy, We can still conclude that inductive teaching methods are compatible with constructivism, in contrast to the traditional lecture-based teaching. Therefore, it is no wonder that Problem-Based Learning (PBL) belongs to the family of IBL, as both share the same epistemological background.

Much published work concludes that IBL is generally more effective than traditional teaching. For example, [94] found that IBL produced significant positive gains for both cognitive and non-cognitive learning outcomes, as compared to traditional instruction.

Though many educators have embraced IBL, it is not without its critics. For example, Mayer [84, p. 18] argues that *pure* discovery-based teaching is not as effective as a *guided* discovery-based one; he provides empirical research as evidence to support his argument:

"Nothing in this article should be construed as arguing against the view of learning as knowledge construction or against using hands-on inquiry or group discussion that promotes the process of knowledge construction in

learners. The main conclusion one can draw from reading this literature that I have reviewed, is that it would be a mistake to use pure discovery during early learning as a method of instruction."

My own teaching experience provides evidence that also supports the above argument: Pure discovery can be suitable for knowledgeable learners, but may not be useful for novices.

As an example of the application of Inquiry-based learning (IBL) in upper secondary school mathematics, students may be asked to experiment with a Computer Algebra System (CAS) to give an interpretation of the coefficients  $a$ ,  $b$  and  $c$  in the quadratic function  $f(x) = a \cdot x^2 + b \cdot x + c$ , by using "sliders" to vary the coefficients, one at a time, in order to see how the graph will change (Fig. 1). Driven by curiosity, students are thus given the opportunity to formulate hypothesis and draw conclusions about the coefficients.

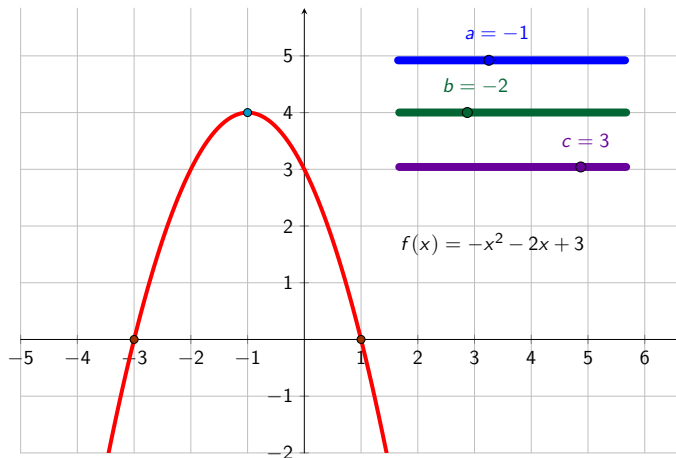


Fig. 1: Using CAS to support inquiry.

In general, computer technology and software play an important role in the development and support of IBL in mathematics and engineering [10, p. 10].

In my paper E: "Inquiry-Based Teaching in Engineering: The Case of Transfer Functions", IBL is implemented in an engineering course on systems modeling and simulation, using computer software.

## 2.3 Variation Theory

Variation theory (VT) is a way of analyzing and planning teaching and learning activities. The theory focuses on what changes and what stays the same and the effect these might have on the students' understanding of a phenomenon or a topic. It emphasizes variation as a necessary condition for learners to be able to discern new aspects of an object of learning.

VT grew out of the phenomenography tradition that usually denotes "the qualitatively different ways in which people are aware of the world, and the ways in which they experience various phenomena and situations around them." [82, p. 535]

Variation Theory (VT) posits that seeing differences precedes seeing sameness and that learning implies seeing or experiencing critical aspects of an object of learning [80, 81]. For example, to understand the concept of a linear function  $f(x) = ax + b$ , one needs to know how it differs from non-linear ones.

"You cannot possibly understand what Chinese is, simply by listening to different people speaking Chinese if you have never heard another language, and you cannot possibly understand what virtue is, by inspecting different examples of the same degree of virtue. Nor can you understand what a linear equation is, by looking only at linear equations" [83, p. 25].

Marton [80, p. 263] proposed a sequence of the patterns of variation and invariance for the students to completely discern a phenomenon, situation or a concept. The object of learning, which can be a problem to solve or getting the students to be acquainted with a situation, should be followed by **contrast**, **generalization**, **separation** and finally **fusion**.

In my paper C: "Exploring Students Conceptions of Vectors: A Phenomenographic Study", Variation Theory is used in a teaching session about vectors, in connection with an engineering mechanics course.

## 2.4 Theory of Didactical Situations

The origins of the Theory of Didactical Situations (TDS) date back to the late 1960s, when the French mathematics didactician Guy Brousseau started to think about the conditions that would ensure a rigorous construction of mathematical knowledge in a model of teaching and learning systems, as well as to determine the conditions of scientific observation of didactic activities. This section introduces the tenets of TDS that is used in section 5 of this thesis,



as well as in Paper B. For more details, the reader can consult the English translation of Brousseau's original work [29].

The commitment of TDS to mathematical epistemology is reflected in the meaning attributed to the notion of *fundamental situation*: "a situation which makes clear the *raison d'être* of the mathematical knowledge aimed at" [12, p. 803]. In other words, a fundamental situation is a model or representation of a mathematical knowledge, using problems for which that knowledge is an answer. Presumably, by interacting with an appropriate *milieu*, students gradually construct knowledge by rejecting or adapting their initial strategies if necessary. The milieu can be defined as the medium with which the students interact to obtain new knowledge. The milieu can include the problem to solve, the students' prior knowledge and objects like books, notes, computers, etc.

In TDS, the teacher should design and adjust teaching situations, that allow the students to work with a problem, just like a mathematician's first approach to an open problem:

"The intellectual work of the student must at times be similar to this scientific activity. Knowing mathematics is not simply learning definitions and theorems in order to recognize when to use and apply them. We know very well that doing mathematics properly implies that one is dealing with problems. We do mathematics only when we are dealing with problems, but we forget at times that solving a problem is only a part of the work; finding good questions is just as important as finding their solutions. A faithful reproduction of a scientific activity by the student would require that she produces, formulates, proves, and constructs models, languages, concepts and theories; that she exchanges them with other people; that she recognizes those which conform to the culture; that she borrows those which are useful to her; and so on." [27, p. 22].

TDS provides a systemic framework for investigating teaching and learning processes in mathematics, and for supporting didactical design. It does not, however, provide the teacher with a model of "good practice". It is mainly a tool for analyzing and designing teaching situations.

The theory is structured around the notions of *adidactical* and *didactical* situations, and includes a body of concepts, that are relevant for teaching and learning mathematics in the classroom. Didactical situations are those where the teacher explicitly interacts with the students in order to further their learning of some specific knowledge or technique, whereas adidactical situations are those where the students engage with the problem and explore the milieu without the teacher's interference. In adidactical situations, the students are developing their personal knowledge, by adapting it to the problem they work

on, through inquiry activities and testing of ideas in the milieu.

Didactical situations can be one of three main phases:

- **Action phase:** Students autonomously engage in problem solving, using their previous experience and knowledge.
- **Formulation phase:** The students are required to present what they did in the action phase.
- **Validation phase:** The work of the students is validated by the milieu, without the teacher telling them whether they are right or wrong.

The interplay between personal knowledge and institutional knowledge plays a central role in TDS. Personal knowledge is the knowledge that the students construct while interacting with a mathematical problem. Institutional knowledge (also called formal or official knowledge) is the knowledge presented in textbooks, web pages, research journals and other shared resources. According to TDS, the fundamental role of the teacher is to design and calibrate situations that enable the students to acquire new knowledge, by developing their personal knowledge until it is consistent with institutional knowledge. The *institutionalization* of personal knowledge and the *de-institutionalization* of institutional knowledge constitute a didactic cycle that should be used whenever new knowledge is introduced (Fig. 2).

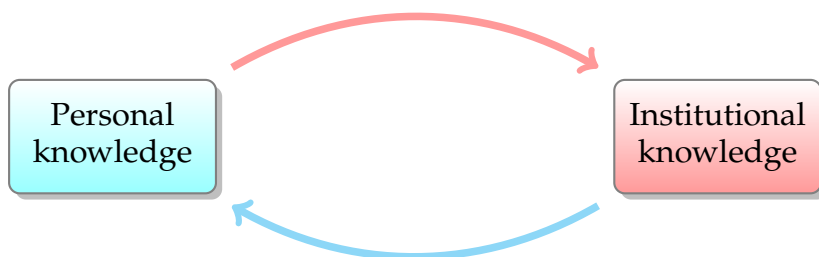


Fig. 2: The cycle of personal knowledge and institutional knowledge.

TDS strives to offer a model, inspired by the mathematical theory of games, to investigate, in a scientific way, the problems related to the teaching of mathematics and the means to enhance it. According to TDS, learning is understood as sense making of situations in a milieu, and also developing ways of coping with the milieu. Teaching of some knowledge consists of organizing the didactical milieu in such a way that this knowledge becomes necessary for the student to *survive* in it.

In the *design* of teaching situations, these are usually organized into five phases and ordered as illustrated in Fig. 3. The situations are connected by the so-called the *didactic contract*, which regulates the interaction of the teacher and the students with respect to the mathematical notions at stake. The didactic contract was described by Brousseau as a set of rules that describe the mutual expectations and responsibilities of students and teachers in the classroom.

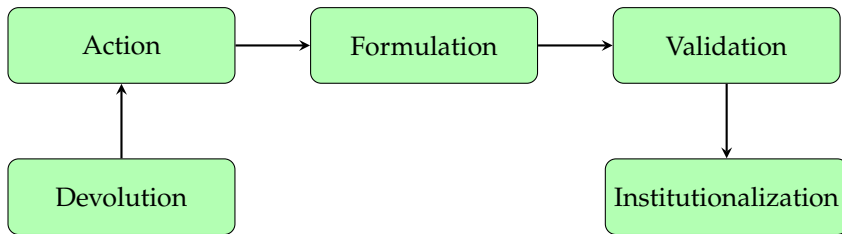


Fig. 3: The phases of didactical situations.

The rules of a didactical contract are generally implicit, in contrast to an ordinary contract, and are sometimes seen when the contract is unsuccessful or broken for various reasons [31]. The teacher's part of the contract is to create a milieu for the students in which they can learn the required topic. The students' part of the contract is to engage in the milieu in order to acquire the knowledge the teacher requires. Within this contract, the work of the teacher is referred to as the didactical situation and the work of the students is referred to as the adidactical situation.

It is important to emphasize that the central object of TDS is not the cognizing individual student, but the *situation*, which regulates the adaptive processes the students can develop, and thus the mathematical knowledge they can construct [5].

TDS was implemented in Paper B: "Teaching the Limits of Functions Using the Theory of Didactical Situations and Problem-Based Learning", where I designed teaching situations that led to the rigorous definition of limit of a function.

Moreover, TDS was applied in my course "System Modeling and Simulation" in Autumn 2019, as documented in section 5 of this thesis.

## 2.5 The Anthropological Theory of Didactics

The Anthropological Theory of Didactics (ATD) is a new approach to the didactic mathematics that was introduced by the French mathematician Yves Chevallard in 1991 [33]. It considers the teacher as the director of the didactic process that the students carry out.

ATD is an epistemological model of mathematical knowledge that can be applied to investigate human mathematical activities through so-called *praxeologies*. A praxeology consists of two components, *praxis* and *logos*. The main idea of the concept of praxeologies is that all human activities comprise and link two parts: A practice and a theory.

The praxis or practical block itself consists of two parts: A type of task ( $T$ ) and technique ( $\tau$ ). The type of task ( $T$ ) is a specific kind of problems given to the students.

"Every human action is understood as motivated by something (a task) which the action is carried out to achieve; in other words, every human action is considered intentional or motivated (or at least, we only study activity which can be so considered). What we actually do to carry out the task, is what is called a technique." [108, p. 7]

At the university, the task can, for example, be taken from a mathematical textbook, such as the task of solving linear differential equations. The students need a technique ( $\tau$ ) to solve the task, for instance, rewriting the equation in a suitable form in order to use a solution formula.

The logos or knowledge block comes from a Greek word that refers to human thinking and reasoning about the cosmos [34]. It also consists of two parts: A technology ( $\theta$ ) and a theory ( $\Theta$ ). The technology ( $\theta$ ) is about the justification and explanation of the technique ( $\tau$ ) by the students to solve the task.

The technology may itself be explained and justified by what is called theory. For example, the topic "linear differential equations" is the theory ( $\Theta$ ) to explain the technology ( $\theta$ ).

The four elements in the quadruple ( $T, \tau, \theta, \Theta$ ) are related and constitute a holistic model to study human knowledge.

The concept of praxeologies is used in Paper E: "Inquiry-Based Teaching in Engineering: The Case of Transfer Functions" to support the argument that new techniques linked to the use of CAS tools in engineering education may have genuine epistemological value for the students and can supplement

paper-and-pencil techniques to contribute to the improvement of the learning process.

The Anthropological Theory of Didactics (ATD) and the Theory of Didactical Situations (TDS) are in fact two neighboring theories coming from the same French didactic tradition. Both theories have a strong interest in the epistemology of mathematics and "each one reinterprets and reformulates the problems raised by the other." [6, p. 1535]

## 2.6 Didactical Engineering

The term "Didactical Engineering" (DE) was introduced in France in the early 80s to describe a research approach in mathematics education that is similar to the work of an engineer. When carrying out a project, engineers apply scientific knowledge in mathematics, physics and engineering science. In addition to that, they are required to solve more complex problems than those of science, including empirical investigations of phenomena and designing products that should meet *other* requirements than the technical ones [7, p. 283]. Didactical engineering is associated with teaching experiments and designing lessons in classrooms, in an attempt to test some theoretical ideas [8]. It can be defined as a *non-cyclic* approach to the design and analysis of theoretically justified sequences of mathematics teaching, aiming at bringing about some educational phenomena, and also to develop instructional resources, that are tested in practice. In other words, DE is "a tool for answering didactical questions for identifying, analyzing and producing didactical phenomena through the controlled organization of teaching experiments." [9, p. 477]

Given the French tradition in the didactics of mathematics from the beginnings of the 80s of the last century, didactical engineering has been the privileged didactical research methodology in France. It is therefore not surprising that the theoretical framework of didactical engineering was the Theory of didactical situations (TDS) [28, 29]. Some features of DE are:

- It is based on the design, implementation, monitoring and analysis of teaching sequences.
- The validation is essentially *internal*, which is based on the comparison between *a priori* and *a posteriori* analysis.
- There is no external validation, which is a validation based on the comparison of students' performances in experimental teaching in the classrooms.

Didactical engineering addresses case studies, using the following phases [7]:

1. Preliminary analysis.
2. Design and *a priori* analysis of teaching situations.
3. Experimentation in the class room.
4. *A posteriori* analysis and evaluation.

As suggested by [90, p. 59], didactical engineering from the beginning "is more than a research methodology: it is also intended as a didactic transposition viable in the ordinary teaching". In other words, didactical engineering can be considered both as a product and a method.

As mentioned above, the evolution of didactical engineering was linked to the Theory of didactical situations (TDS) itself, or to the application of other theoretical models inspired by TDS, such as the Anthropological Theory of Didactics (ATD) [35].

[90] distinguishes two types of didactical engineering according to the primary research objective:

1. Didactical engineering for research aims at producing research results, using methods that depend on the research question at stake, with no intention of making generalizations of the methods used.
2. Didactical engineering for development and training; the purpose here is the production of educational resources for instructors and teacher training.

Didactical Engineering was used in a seminar I held on August 30, 2019 at the Department of Science Education, the University of Copenhagen. The title of the seminar was "A Friendly Introduction to Differential Calculus Using Didactical Engineering".

## 2.7 Design-Based Research

One could conceive design-based research (DBR) as a family of educational, research-based methodologies that are used to develop instructional resources to improve teaching and learning at schools and universities. DBR involves primarily the design of *interventions* or experiments in the class room. The

interventions are then implemented to test how well they work, and may be adapted and re-tested to gather more data. The aim of DBR is to generate new theoretical frameworks for conceptualizing teaching, learning and educational reform. Data analysis often takes the form of iterative comparisons.

According to [2, p. 16], DBR "evolved near the beginning of the 21<sup>st</sup> century and was heralded as a practical research methodology that could effectively bridge the chasm between research and practice in formal education". The so-called Hypothetical Learning Trajectory (HLT) is a basic ingredient of DBR. Basically, it involves the learning outcomes of a subject, assumptions about the students' potential learning processes and about how the teacher could support these processes [16, p. 446]. The interplay between the HLT and the empirical results of the research is the fundamental component for developing the teaching interventions. A good collaboration between researchers and instructors is essential for the success of the iterative adjustment and refinement of the interventions. This collaboration is carried out through dialogue and reflective processes before, during and after each teaching experiment.

According to [72], DBR consists of various approaches for the study of learning *in context*. It utilizes the design and analysis of teaching methods, in such a way that the design and research be interconnected. DBR asserts that if research in education is separated from the practice of education, it cannot take into account the influence of learning environments on the results of the research, nor it can adequately identify its limitations and range of applicability: "We argue that design-based research can help create and extend knowledge about developing, enacting and sustaining innovative learning environments" [40, p. 5]. These authors used the term design-based research to distinguish their approach from the traditional experimental design in teaching, by giving five features to these methods:

1. The design of learning environments and the development of theories of learning are interconnected.
2. DBR is a cycle consisting of the following stages: Design, ratification, analysis, and redesign.
3. DBR must lead to theories whose practical implications can be shared with instructors and educational designers.
4. DBR must provide a description of how the designs work in authentic settings. It is not enough to report the success or failure of an educational design. DBR should also lead to the improvement our understanding of the learning issues involved.

5. "The development of such accounts relies on methods that can document and connect processes of enactment to outcomes of interest." [40, p. 5]

DBR also describes how to carry out design studies, i.e. the investigations of educational interventions. "Often, what gets designed is a whole 'learning environment' with tasks, materials, tools, notational systems, and other elements, including means for sequencing and scaffolding" [93, p. 38].

Moreover, DBR encourages theory building that incorporates elements beyond the observations. "Design experiments are conducted to develop theories, not merely to empirically tune what works." [38, p. 9]

In [45], the authors regard theory building as an important role in what they call the "ontological innovation": The invention of new categories that are useful in the creation, choosing and evaluation of design alternatives.

In DBR, a design experiment consists of three stages [39]:

1. Planning of the experiment.
2. Experimentation in a learning environment.
3. Analysis and explanation of the data generated by the experiment.

According to [41], design experiments involve two fundamental parts aimed at improving educational practice: The focus of experiment design and the evaluation of the results. These experiments can however give rise to issues such as:

- Difficulties arising from the complexity of real-world situations that render them unamenable to experimental control.
- Large amounts of data arising from the need to combine ethnographic and quantitative analysis.

It should be mentioned that there is a substantial difference between DBR and Didactical Engineering (DE). The later is closely related to the methodological approach provided by a didactical theory, such as the Theory of didactical situations (TDS). The close relationship of DE with TSD and The Anthropological Theory of the Didactic (ATD) provides explicit criteria in the design, implementation and analysis to test and develop the didactical theory itself. By contrast, although design-based research has similar goals, it does not adopt specific theoretical frameworks. DBR is, therefore, a category



of educational research perspectives bonded for the interest or focus in the design, implementation and evaluation of educational interventions in naturalistic contexts, without explicit interest in epistemological questions. "A very noticeable aspect of the design research literature is the absence of discussion of epistemological issues." [106, p. 53]. In DE, by contrast, epistemological questions are central because they are crucial in TDS and ATD.

## **2.8 Action Research**

Action research is a reflective and cyclical process in which an educator examines his/her own educational practice systematically and carefully, using the techniques of research in order to improve and/or refine the teaching and learning process [15]. It is used in real situations, rather than in experimental studies, since its main focus is on solving immediate, real problems.

Action research is an interactive method of collecting information that is used to explore topics of teaching, curriculum development and student behavior in the classroom. In that regard, I made extensive data collection in the form of pre-tests, post-tests and delayed post-tests that consist of some basic questions from the mathematics curriculum of the upper secondary school system in Denmark.

It should be pointed out that several models of action research are available to teachers wishing to engage in this research methodology [66]. In [101], for example, action research is described as a cycle of research inquiry, consisting of five major steps: designing the study, collecting data, analyzing data, communicating outcomes, and taking action (Fig. 4).

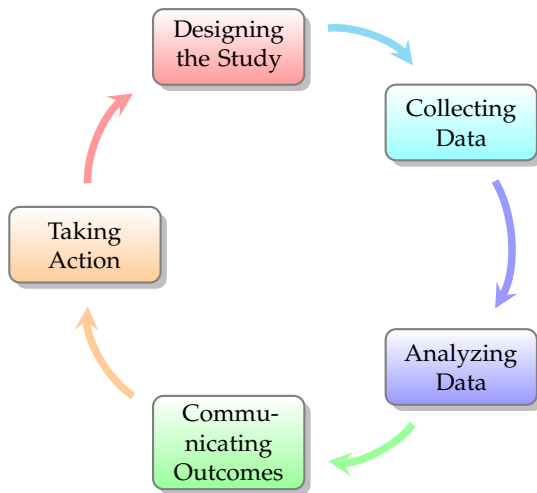


Fig. 4: The action research cycle (adapted from [100, p. 5]).

Action research can be helpful in bridging the gap between theory and practice in education. In fact, the iterative nature of action research inspired me to suggest a didactical modeling cycle, which I actually use in my own teaching practice.

The didactical modeling cycle is described in section 8 of this thesis.

### 3 Mathematical Modeling

#### 3.1 Introduction

Our planet suffers from many environmental problems, including climate change and pollution, that are mainly caused by the unsustainable nature of human activities [70]. These problems themselves generate new scientific challenges that involve much risk and uncertainty. Since mathematics is not a closed system but a human activity that has a relation with the reality [104], the language of mathematics is crucial to our understanding, representation and description of these challenges in order to make predictions about how they will proceed, and to communicate about them. The belief that the laws of nature are written in the language of mathematics was made almost four hundred years ago:

"Philosophy is written in this grand book, the universe, which stands continually open to our gaze. But the book cannot be understood unless one first learns to comprehend the language and read the letters in which it is composed. It is written in the language of mathematics, and its characters are triangles, circles, and other geometric figures without which it is humanly impossible to understand a single word of it; without these, one wanders about in a dark labyrinth." [55]

A possible "mismatch" between a representation and the part of reality it claims to represent, triggers a "cycle" of refinements of such representation. The representation itself is not just a simplified image of some part of an objective reality, but constitutes a new reality of its own, dependent on the intentions and interests of the problem solver. Putting a mathematical representation in the context of real situations can eventually lead to better understanding of both realities.

Moreover, new representations may be created to cope with the increasing complexity of the challenges of the real world. As an example, physicists had long used the Dirac delta function (the  $\delta$ -function) [44, p. 58] to model the density of an idealized point mass or point charge as a function that is equal to zero everywhere except at zero and whose integral over the entire real line is equal to one [3, p. 84]. As there is no function that satisfies these properties, the computations made by theoretical physicists appeared to mathematicians as nonsense, until the introduction of the theory of distributions by Laurent Schwartz [57, p. 3] to formalize and validate the computations [57].

## 3.2 The Modeling Cycle

We make sense of real-life situations and interpret them by constructing an analogy between the unknown situations and the known ones. According to [78], the term "models" denotes both the conceptual systems in people's minds as well as the external notations of these systems, such as representations and rules.

A mathematical model involves the structural features and functional principles of objects or real-life phenomena, using mathematical representations and rules.

Basically, mathematical modeling involves a non-routine mathematical task<sup>1</sup> to solve a real world problem. It can be defined as the application of mathematics

---

<sup>1</sup>A non-routine mathematical task does not usually have an immediately apparent strategy for solving it.

to a real world situation or problem. Mathematical modeling can also mean the model building process, that starts with a real situation and leads to the mathematical model itself [22].

Mathematical modeling is a process of using various mathematical structures, such as differential and algebraic equations, graphs, diagrams and scatter plots, to represent real world situations. Since mathematical models are representations or descriptions of reality, they only depict reality and should not be confused with the reality, one is trying to model, as a noted linguist once wrote “The symbol is NOT the thing symbolized; the word is NOT the thing; the map is NOT the territory it stands for” [63]. The model provides an abstraction that reduces a problem to its essential characteristics and ingredients.

In the research literature about teaching mathematical modeling, it is agreed that the modeling process is a cycle that starts and ends with a problem situation in real life or in a non-mathematical discipline, and that there is a translation (or *coding*) of the problem into tractable mathematical formulations whose theoretical and numerical analyses provide insight, answers and guidance, that are useful for solving the original problem. It is possible, and in fact usual, to go round the cycle more than once.

Examination of textbooks dealing with undergraduate mathematical modeling (or any of the related fields in engineering science) will usually yield a description of the mathematical modeling process in general terms, incorporating the following stages, which the modeler should go through.

- **Problem:** Identify variables in the situation and selecting those that represent essential features.
- **Formulation:** Formulate a model by creating and selecting geometric, graphical, tabular, algebraic or statistical representations that describe the relationships between the variables.
- **Solution:** Analyze and perform operations on these relationships to draw conclusions.
- **Interpretation:** Interpret the results of mathematics in terms of the original situation.
- **Validation:** Validate the conclusions by comparing them with the situation, and then either improve the model or stop, if it is acceptable.
- **Report:** Report on the conclusions and the reasoning behind them.

These stages are outlined in Fig. 5. There are, however, many variations and extensions of the modeling cycle mentioned in both specialist texts on mathematical modeling (e.g. [46]) or research articles on modeling ([21, 49]),

but the basic structure of the process is essentially similar to that shown.

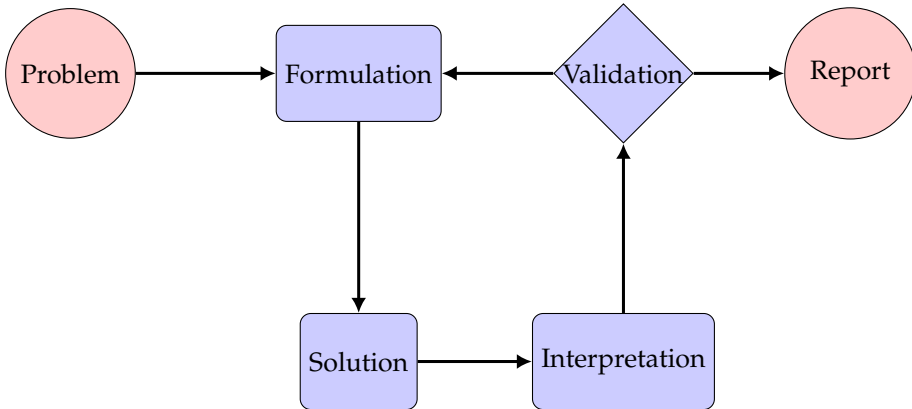


Fig. 5: The mathematical modeling cycle.

The modeling cycle itself is a theoretical description of what real-world modeling involves, and so it, too, should be regarded as a "model": It is not necessarily meant to be a linear process where the modeler should mechanically follow a list of steps. In fact, the process can be better described as holistic.

### 3.3 Modeling Competences

Presumably, a competence in mathematical modeling is considered central in engineering mathematics education. A competence in modeling refers to an individual's ability to carry out required tasks in a modeling situation in order to progress the modeling. It "is someone's insightful readiness to act in response to the challenges of a situation." [20, p. 47]

By acquiring that competence, students should be "able to autonomously and insightfully carry through all aspects of a mathematical modeling process in a certain context." [19, p. 126]

Based on the steps of the modeling cycle, the following modeling competences can be identified [71]:

1. Competence to understand a real-world problem and to extract its real essence.

2. Competence to construct a mathematical model out of a real-world situation.
3. Competence to solve mathematical problems that arise within a mathematical model.
4. Competence to interpret the mathematical results in a real-world situation.
5. Competence to question the solutions and, if necessary, revise the modeling process.

In addition to the above-mentioned competences, I can add a 6<sup>th</sup> one: **competence of reflection**. Teaching mathematical modeling can be an invitation to the students to reflect individually on their performance and how they can improve their modeling skills. In other words, they should look back at the process as a whole, reflecting on what could be improved for the next time.

Thus, it is important to get students into the habit of reflecting on both their work and the work of others, since thinking about the ups and downs of the process that eventually produced the final model, would be a far richer experience for the students than just the presentation of the final model. Moreover, "reflection might well provide material for further reflection, and most importantly, lead to learning and, perhaps, reflection on the process of learning." [73, p. 2]

### 3.4 Challenges in Teaching and Learning Mathematical Modeling

The actual implementation of mathematical modeling falls to the teachers in the classroom. Success depends on their mathematical abilities to model, their pedagogical skills to teach it, and their decisions to allocate time and priority to it. However, many teachers are not confident in their abilities to teach mathematical modeling for the first time without professional assistance [60].

Mathematical modeling is an interdisciplinary subject connecting mathematics with many other fields. Therefore, the subject can make teaching more demanding, since the teacher is required to master additional non-mathematical knowledge and to manage open-ended problems in the classroom.

From the student's point of view, modeling makes mathematics lessons and examinations more demanding and would make these less predictable [24].

In fact, it is well-documented that learning mathematical modeling is a difficult task for students both in upper secondary and higher education [53].

Many researchers in mathematics education have addressed the obstacles of teaching, learning, and assessing mathematical modeling [25]. For example, according to [89], the problems that both teachers and students encounter are:

1. The lack of agreement about the essence and the vision of the modeling process.
2. The complexity of the modeling process entails complexity in the teaching process.
3. Mathematical modeling is, in essence, always about a problem situation in real life, and mathematics is just a part of the whole process.

### 3.5 Merits of Mathematical Modeling

It is no news that mathematics becomes more meaningful and interesting for the students if taught in contexts, such as modeling of a natural phenomena.

In [88, p. 337-338], one can find a series of arguments supporting the claim that mathematical modeling could help in arousing the interest of the students to learn more mathematics; and according to [23], there are four kinds of justifications for the inclusion of the teaching mathematical modeling at schools and universities:

1. **Pragmatic justification:** Appropriate modeling examples have to be thoroughly explained to the students so they can comprehend real world situations.
2. **Formative justification:** Competency in mathematical modeling can be achieved by engaging the students in modeling activities.
3. **Cultural justification:** Understanding the relations of mathematics to the real world is a necessary condition to convey the picture of mathematics as a science in a comprehensive sense.
4. **Psychological justification:** Realistic and authentic examples can make the students realize that mathematics is a useful language and tool to tackle many current challenges, and may contribute to motivate them to take learning mathematics seriously.

Regarding teaching methods in modeling, researchers in modeling favor an investigative approach in teaching the subject, where students act independently and take responsibility:

"It is important to realize however, that formulating the 'right' problem in a situation outside of mathematics is a creative activity much like discovering mathematics itself. Thus our continuing efforts to bring the discovery method to the classroom naturally go hand-in-hand with attempts to bring genuine applications to the classroom." [92, p. 3]

Thus, it seems that teaching mathematical modeling can be successfully achieved if the instructor implements one of the inquiry-based methods. As a modeling example, I can mention "the giant's pair of shoes" (Fig. 6) [4]:

There is a pair of shoes in a sport center in the Philippines. According to Guinness Book of the World Records, it is the largest shoe of the world with the width of 2.37 m and the length of 5.29 m. What is the height of the giant that could actually wear these shoes?



Fig. 6: The giant's pair of shoes.

Moreover, in paper D: "Integrating the Methods of Mathematical Modeling and Engineering Design in Projects", a mathematical model of the popular van and caravan play set by the Danish company Lego, is constructed and analyzed as a design process in an engineering context.

Students may well experience mathematics as a mechanical manipulation of meaningless symbols. Mathematical modeling in a context can contribute towards giving more meaning to the learning and teaching of mathematics, as argued in Paper D.



### 3.6 Some Reflections on Mathematical Modeling

In my own experience, there are other aspects of the mathematical modeling process that cause problems both for teachers and students, beside the involved mathematics itself. These aspects include the difficulty most students encounter in learning about and understanding complex problem situations. I conjecture that this difficulty is partially due to the fact that insufficient time is allocated to the mathematical modeling activity within a course or a project, where students can reflect on their own work in order to activate their *learning-to-learn* skills, since every modeling situation they meet will be different and can often be complex. Moreover, the open nature of many modeling problems requires that instructors must allocate time for giving feedback on the students' conceptions as they emerge.

It is no doubt that teaching mathematical modeling is a demanding task. Instructors must be competent in many facets of knowledge, such as knowledge of the modeling process itself, non-mathematical knowledge of the situation to be modeled, knowledge of the students' backgrounds and experiences and knowledge of pedagogical practices that facilitate individual and group learning.

Thus, it seems that "there is still a substantial gap between the forefront of research and development in mathematics education, on the one hand, and the mainstream of mathematics instruction, on the other hand. In most countries, modeling (in the broad and, even more so, in the strict sense) still plays only a minor role in everyday teaching practice at school and university." [22, p. 3].

For mathematical modeling to be fully integrated in engineering mathematics teaching, modeling should be acknowledged as a didactical means for supporting the students' learning of mathematics. This calls for the development of a platform for genuine collaboration between researchers in modeling and teachers in various institutional contexts.

My conception of mathematical modeling as an open, inquiry-based and dynamic process requires that teachers should also be regarded as learners: Learning to engage the students in mathematical modeling as well as learning from their own practice.

## 4 Research Methodology

My personal entrance into research studies is my interest in improving my own teaching and learning from the students' experiences, using acknowledged educational theories. I sought theoretical components to the research, a framework to understand the students' perspectives and wanted to give my findings rigor and wide application. Moreover, I desired to apply diverse educational theories in the class room, including problem-based learning, which is the fundament of the Aalborg model of PBL, endorsed by our university.

The purpose of this research is to study the implementation of some didactical theories in engineering courses at Aalborg University. I wanted to study how the implementation was received by the students and explore the problems or new understanding that arose in my instructional practices during the adoption of these theories.

It is also the intention of the study to better understand the students' responses, and the contribution of these theories, if any, to improving engineering education.

Regarding research methods, I used both quantitative and qualitative research in my study.

Qualitative research, being inductive in nature, is used to explore and interpret the meaning of the students' experiences and how the students view a particular problem or case. It is more interpretive and contains a lot of writing, and has direct quotes from participants. In qualitative research, researchers use interviews and observations of the participants and their environments and often involves direct quotes from the participants. Qualitative research methods are suitable to understand the students' perspectives which are not quantifiable or easily broken down into a manageable number of variables.

On the other hand, quantitative research involves the use of mathematically based methods (in particular statistics) to test or confirm theories and hypotheses by systematically collecting and analyzing data [42]. Quantitative research, being deductive in nature, can be used to establish results about a topic.

Students have a central role in this study since understanding their perspectives offers the means to answer the research questions of this thesis and achieve the study's purpose.

As my study is conducted on a small number of engineering students, the results will not necessarily be generalizable, but rather the goal is the transferability of the results, such that they could be useful in the application to other similar situations [98]. A complete theoretical study of engineering education would require resources beyond the scope of this study: It is basically an exploratory and interview study.

In my papers, the participants are 42 1<sup>st</sup> semester students, 40 2<sup>nd</sup> semester students and 32 5<sup>th</sup> semester, all enrolled in the "Sustainable Design" engineering study program at Aalborg University. These students were chosen for convenience, since

1. Beside doing research, I was also an instructor and group supervisor, and could therefore conduct interviews, observe how the student groups work, distribute questionnaires and archive records and notes at my pace. As a group supervisor, I gave both professional and pedagogical guidance to support and challenge the students during their work on a problem or project. The group sizes varied from semester to semester, but typically, a group consisted of three to five students.
2. The courses I taught include standard engineering topics, that can be found in many engineering programs.

I wanted to explore the experiences and possible frustrations of the student groups when working on a problem or a course project and to understand how they tackled new engineering and mathematical problems in the project. I did not use a specific set of questions in the interviews as I wanted to allow the students to talk in some depth, choosing their own words. This would help me develop a real sense of a student's understanding of the situation at hand.

Therefore, I used unstructured group interviews with open-ended questions as well as participant observations [75] of how they worked with the course project. The open-ended questions were mostly "what if" questions because I wanted to understand how they think new ideas and where there are flaws in their arguments.

I observed the students in their group rooms while they were doing the exercises following the lectures and listened to their conversations and asked them to involve me in the learning process and accept me as a "listening member" of their groups. I wrote notes that included their discussions and the calculations they made. Each group observation lasted between 10 and 15 minutes.

Regarding the interviews, I asked them to describe what they did to understand the topics involved in the projects and what references they consulted and why they used the formulas that I observed. When I discovered inconsistencies in their arguments or mistakes in their calculations, I did not attempt to correct them immediately, but rather challenged their arguments by asking about the practical consequences of their method and what their calculations would lead to in order to let them learn from their mistakes. Each group interview lasted between 15 and 20 minutes. The group interviews were audio-recorded, using a cell phone.

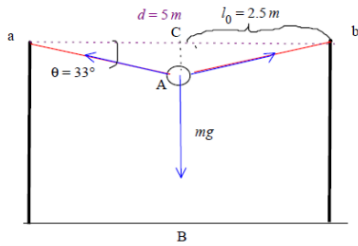
As an example of a group interview, I can mention the following interview that took place in February 2020 in connection with my course "Dynamics & Vibrations", given in Spring 2020 to 2<sup>nd</sup> semester students, following the study program "Sustainable Design" at Aalborg University.

In the course, the students are required to work on several real-life mini projects, where they themselves should take the necessary measurements. In one of these projects, the students are asked to estimate how far the girl descends before she again becomes momentarily at rest (Fig. 7).



Fig. 7: A course mini project in Dynamics.

I observed a group of three students working on the mini project. They did in fact use a correct method to solve the problem, by arguing that the work-energy theorem in Dynamics is appropriate here, since there are two positions of the girl. I have noted their solution, shown in Fig. 8. I noticed that two students were actively engaged in the discussions and calculations while the third student was almost silent.



(a) A free-body diagram drawn by the students.

$$k(x_1)^2 + m \cdot g \cdot h = k(x_2)^2 \xrightarrow{\text{solve for } h} [[h = 1.402353813 \text{ m}]]$$

(b) A part of the students' calculations.

Fig. 8: A part of the students' solution.

**Teacher:** How did you come up with this formula?

**Student 1:** We looked in the notes you posted on Moodle and found a worked example involving springs, where you used the work-energy theorem, and we thought that our problem is similar to the worked example.

**Teacher:** Very good, indeed.

**Teacher:** Are there other methods to solve the problem?

7 sec silence

**Student 2:** Can we use Newton's 2<sup>nd</sup> law?

**Teacher:** What do you think?

**Student 1:** I think it is also correct to use it.

**Teacher:** Yes. But what about the acceleration? How do you find it, Student 3?

**Student 3:** The girl is falling and the weight is  $mg$  so we can use  $g$  (gravitational acceleration).

**Teacher:** Does the girl fall with a constant acceleration?

5 sec silence

**Student 2:** I don't think so because the girl is slowing down and this is not the same as a free fall.

**Teacher:** Yes, you are right.

With respect to quantitative research, I used questionnaires that include tasks about some basic topics in mathematics and mechanics that are usually covered in the syllabus of mathematics and physics at the Danish upper secondary school. The questionnaires consisted of 11 problems that should be solved by hand and are arranged in the same order that the students had at the upper secondary school. In preparing the problems in the questionnaires, I was inspired by a similar study made at the University of Southern Denmark to investigate the use of digital tools by 1<sup>st</sup> year engineering students [86], even though I used my own problems, that I considered relevant to the "Sustainable Design" engineering study program. These problems were thus deliberately chosen because they represented necessary background knowledge in mathematics and mechanics, that is a prerequisite for the compulsory mathematics and engineering science courses in the study program.

The problems were given three times to the same students in the form of pre-test, post-test and delayed post-test. The pre-test was given at the beginning of the course, the post-test at the end and, finally, the delayed post-test was given one semester after the course ended.

The assessment of the students prior knowledge through a pre-test would give me an overview of *how* and *how far* the students "*remember*" some prerequisites of the courses. On the the hand, the pre-test could give the students a glimpse of the new topics expected in the courses and would eventually alter their learning experience.

The purpose of the delayed post-test was to analyze the lived knowledge <sup>2</sup> of the students as well as to enable me to perceive whether the changes in knowledge have a long-term effect or only a short-term effect of the given lesson, since tests taken directly after the lesson are not indicators of long-term change in the students' experience.

The tests were collected and graded and their results were analyzed using descriptive statistics. In addition a paired *t*-test was conducted in order to find out if there were significant differences between the students' scores of the pre-test and the delayed post-test in the questions about vectors. The results are found in paper C: "Exploring Students Conceptions of Vectors: A Phenomenographic Study". I intend to use the rest of my data collection in future articles.

The results of the tests are used as new data to improve the teaching and learning in the next *iteration* of the course. I use the term "*iteration*", and not "*repetition*", because some substantial changes would have to be made

---

<sup>2</sup>The lived knowledge is what the students actually acquired from different sources, such as learning situations.

in the next time the course is offered. Unlike iteration, the term "repetition" may not suggest adjustment or modifications in the didactics of the course. This iterative didactical process is similar to the mathematical modeling cycle, where the outcomes of the model are interpreted and evaluated by comparing them with reality and/or purpose of the model and, if necessary, going around the cycle more than once.

Below, I mention some of the problems used in the questionnaire.

1. Find the values of the following expressions:

a)  $\frac{3}{\frac{1}{3}}$

b)  $\sqrt{16+9}$

c)  $(-1)^{2019}$

3. Given the function  $f(x) = x^2$ .

a) What is  $f(2)$ ?

b) What is  $f(2t)$ ?

5. Write an expression of the total price of 7 apples and 9 oranges. The price of 1 apple is  $x$  and the price for 1 orange is  $y$ .

6. Solve the following equations:

a)  $x^2 - 2x + 1 = 0$

b)  $e^x = 0$

9. Convert 36 km/h to m/s.

In the following section, Brousseau's theory of didactical situations (TDS) [29], a major framework in mathematical education, is implemented in an engineering modeling and simulation course, given to 5<sup>th</sup> students, enrolled in the study program "Sustainable Design" at our University in Autumn 2019. 35 students participated in the course. Here I also used qualitative research in the form of group observations, unstructured group interviews, testimonies of the group members and recording the discussions with the groups.

I was aware of two applications of Brousseau's theory in the didactics of science education but could not find any attempt to use it in an engineering course. Thus, this study would hopefully fill a gap in the literature.

## 5 Brousseau in Action: Using TDS in Engineering

The main purpose of this section is an attempt to apply the framework of the Theory of Didactic Situations (TDS) in the course "System Modeling and Simulation", given for 5<sup>th</sup> semester students following the engineering program "Sustainable Design" at Aalborg University. The course ran for the first time in Autumn 2019. I became acquainted with TDS after following the graduate course "Advanced Didactics of Mathematics" at the University of Copenhagen. The course was given by Professor Carl Winsløw in Autumn 2018. At that time, I wondered what a course in the didactics of mathematics could possibly contribute to my own teaching of engineering science courses at Aalborg University. According to the syllabus of the engineering study program "Sustainable Design", the course "System Modeling and Simulation" should include the topics below:

- Mathematical modeling of physical systems, such as mechanical, electrical and fluid systems.
- Transfer functions of commonly used elements and systems.
- Matrix methods for systems of differential equation.
- Linearization of non-linear systems.
- Simulation of mathematical models using MATLAB and Simulink<sup>3</sup>.

I was given the responsibility of designing didactical situations and finding teaching materials for the course, that would prove appropriate to the engineering students following the study program "Sustainable Design". Unfortunately, all the texts that I examined for possible adopting in the course were written from a traditional point of view: They present all the concepts and gradually build the theory involved, give some examples and applications, and then ask the students to solve standardized exercises and problems with predefined methods.

The widely used textbook by Ogata [87], for example, contains many examples of mathematical models that, on the one hand, have been developed by others, and on the other hand, written nearly always in the spirit of justification rather than the spirit of *inquiry*. By this, I mean that the writing justifies the final product. However, it does not dwell on the frustrations and problems that may have been encountered on the way to the final model, the models that were discarded, or false trails that were followed. It is of course sound to help students by distilling a problem in the beginning so they can immediately

---

<sup>3</sup>Matlab and Simulink are registered trademarks of the software company MathWorks, <https://www.mathworks.com>



see the important factors to be considered. However, doing so from start to finish prevents the students from engaging in inquiry and constructing their own knowledge autonomously and eventually robs them of the feelings of investment and accomplishment in their work.

“Despite good intentions and much research, most teaching can still be characterized as transmission of syntheses that is the cultivated version of knowledge as it is presented in most textbooks.” [69, p. 4]

The traditional method of teaching mathematics and engineering concepts in the same way as they are presented in these texts has at least two problems:

- It does not necessarily arouse the students’ curiosity as it simply asks the students to imitate the teacher [96].
- The traditional way of teaching contradicts the mission and vision of our University<sup>4</sup> that include research-based education and problem orientation, to name a few.

Since my aim is to perform better as a teacher and an educator, I therefore made the decision to base the course on one major approach for Inquiry Based Mathematics Teaching (IBMT)<sup>5</sup> [12], namely TDS: I wanted to design teaching situations that enable students to acquire the sought knowledge and create potentials for their inquiry.

Transferring TDS from its origin in mathematical education into other disciplines is not new. In fact, I was aware of at least two attempts of using TDS in the didactics of science education: One in pharmaceuticals [37] and the other in biology [48]. In each of the two articles, the students were introduced to a mysterious observation which they have to resolve.

I used qualitative research [62] as a research methodology. The qualitative research method consisted of group interviews as well as the observations of the group presentations in the formulation and the validation phases. This allowed me to get some information about how the students experienced this "new practice" as well as feedback about the whole teaching project related to its learning outcomes. The group interviews were audio-recorded, using a cell phone, and the group presentations were uploaded to Aalborg University learning management system (LMS), *Moodle*. Since this is the first time that I applied TDS in my teaching, the data collected could enable me to acquire

---

<sup>4</sup><https://www.en.aau.dk/about-aau/strategy-vision-mission/mission-vision-values/>

<sup>5</sup>Inquiry Based Mathematics Teaching (IBMT) is a teaching method that allows the students to be engaged in a problem, which leads them to adapt their existing mathematical knowledge or acquire new knowledge.

deeper understanding of the experience gained from implementing TDS in an engineering course, along with improving the educational processes.

This section attempts therefore to answer the following research questions:

- Does the transfer of TDS into the course increase the students' learning of fundamental knowledge in mathematical modeling?
- What are the issues, if any, of transferring TDS to the course?
- Are there key elements of teaching mathematical modeling that can be appropriately mapped onto TDS?

## 5.1 Presentation of the Case Study

The lesson started by giving the students the following task:

- Given the water tank shown in Fig. 9. The input flow rate  $q_i(t)$  is a known constant. How is the water height  $h(t)$  related to the input flow  $q_i(t)$  and the output flow  $q_o(t)$ ?

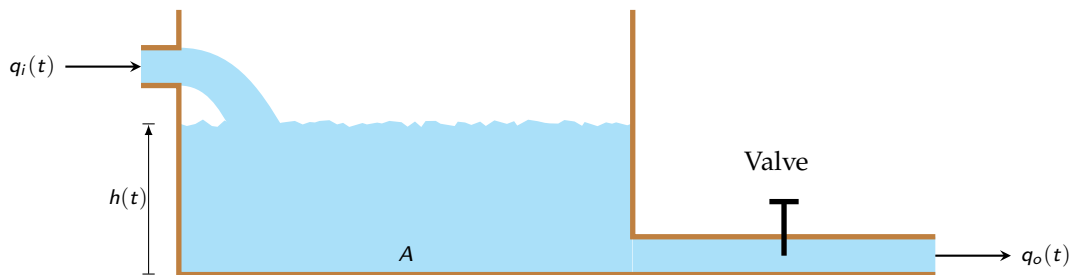


Fig. 9: A fluid system.

Assume that:

1. The density of water  $\rho$  is constant.
2. The cross-sectional area  $A$  of the tank is constant.

I reminded the students of the law of conservation of mass. This is a devolution task, where I simply handed over the milieu to the students. The task can also be regarded as *potentially* adidactic, as I may have to intervene to modify the milieu.

I was aware that the milieu could provide some feedback to the actions of the students, but this feedback alone may be insufficient for the students to

produce new knowledge on their own. The purpose of this task was to lead the students to an institutionalized knowledge of the fluid system:

$$A \cdot \dot{h}(t) = q_i(t) - q_o(t) \quad (1)$$

## 5.2 The Devolution Phase

I elaborated on Equation (1) by saying that we still can't solve the equation for the water height  $h(t)$ , even though  $q_i(t)$  is a known constant. What about  $q_o(t)$ ? How do we find it? How does it depend on the height? The discussion was open to the whole class. The aim here was to make students aware of their lack of knowledge regarding the outflow rate  $q_o(t)$ , in spite of the frustration this may have resulted in.

The students did not get any feedback from the milieu. I changed it by asking a slightly different question: How do scientists or engineers find a relationship between two observed variables? Yes, measurements! I wanted the students to work as engineers in order to discover empirical laws that are valid for a confined part of reality (in this case a simple fluid system), in contrast to natural laws which have more generality, and to help them obtain knowledge about the physical system by linking the observed phenomena with the mathematical model of the system [1].

In fact, within the framework of TDS, the work of the student should be similar to that of a scientist. The scientist produces (public) knowledge while constructing and interacting with concrete situations of inquiry, and the personal knowledge achieved must also be de-contextualized (although, in general, the two processes are not separate). [107, p. 25]

Moreover, the students are expected to make their own observations and perform their own measurements so that they became the owners of the problem.

I already arranged a lab experiment specifically for this case study (Figure 10). The experiment was deliberately designed so that it could result in two different relationships between  $q_o(t)$  and  $h(t)$ , depending on how the students connected the hoses and whether the hoses were bent. Half of the class worked in groups on one setup. Similarly for the other half. The experimental outcome can thus be regarded as an open, interdisciplinary problem, for which the student groups should try to find a solution.

I introduced the experiment in the lab, asking the students to make mea-

measurements of time  $t$ ,  $q_o(t)$  and  $h(t)$  and record the measurements in a data file. Moreover, the students themselves should find numerical values of the geometry of the bucket. The students then should use regression analysis to find the “best” model of  $q_o(t)$  as a function of  $h(t)$ . They were allowed to use *RStudio* to find the regression line, as they learned about *R* and *RStudio* in a statistics course they followed in the same semester.

I have also showed the students some introductory videos on learning MATLAB and Simulink, in addition to some hands-on exercises on using the software.

The students worked on (domestic) buckets of water in the workshop and they themselves should find expressions for the (changing) volume of water in the bucket. I only reminded the students of the volume of a frustum of a cone (Fig. 11):

$$V = \frac{1}{3} \cdot \pi \cdot h \cdot (r_1^2 + r_1 \cdot r_2 + r_2^2) \quad (2)$$

(a) Preparing the experiment.



(b) Starting the experiment.



(c) Measuring the water height.



(d) Measuring the outflow rate.

Fig. 10: The phases of the experiment.

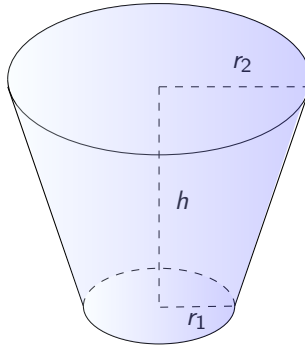


Fig. 11: frustum of a cone.

### 5.3 The Action Phase

In the action phase, the students engaged groupwise in the problem. This was followed by whole class discussions of the solution to the problem. The action phase is similar to a researcher's first approach to an open problem. I often joined the groups as a "guest member", taking part in the group discussions, where I referred to some institutionalized knowledge and to helped the students with the new software, not with the problem solution itself.

The institutionalized knowledge given was not the same for all groups but depended on the actual experience, knowledge and skills of the group members. The groups themselves were allowed to interact with each other.

As I expected, the groups came up with two different results:

1. A linear relationship between the outflow rate and the water height

$$q_o(t) = k_1 \cdot h(t) + b_1 \quad (3)$$

where  $k_1$  and  $b_1$  are constants to be determined by regression analysis. (The constant  $b_1$  accounts for the fact that the bucket was full of water in the beginning of the experiment).

2. A non-linear relationship of the form

$$q_o(t) = k_2 \cdot \sqrt{h(t)} + b_2 \quad (4)$$

where, again,  $k_2$  and  $b_2$  constants to be determined by regression analysis.

The student groups worked with Simulink to obtain a graph of the water height as a function of time. The graphs will, of course, depend on the empirical relationships they found in the experiment.

The group work in the action phase should not be underestimated:

- It can lead to a standardization of knowledge among peers.
- It encourages discussions of different solutions and strategies of solution.
- It can improve the ability of students to communicate mathematical and scientific ideas.

The following are excerpts from two interviews we made with two groups of the class.

- **Group 8:**

This group was doing measurements on the water bucket in the workshop. They complained that they could not find "a good" measurement of the cross-sectional area  $A$ .

**Teacher:** Why did you use  $A \cdot \dot{h}(t)$  in the equation  $A \cdot \dot{h}(t) = -q_o(t)$ ?

**Student 1:** Because it represents the time rate change of the water volume in the bucket. You have written it on the board!

**Teacher:** What does  $A$  stand for? Is it the area of the bottom of the bucket, the top or what?

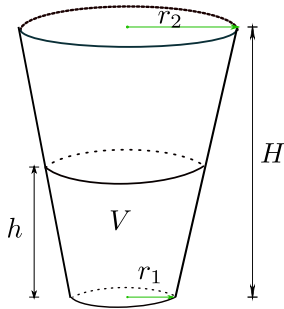
**Student 2:** But these areas are not the same so we were not sure which area is the right one to use.

**Teacher:** You are right that the area is a not a constant as in my example. It is a variable just like the volume of water in the bucket.

**Student 1:** But then we have to find the variable volume of the water in the bucket. How can we do that?

**Teacher:** Good. I will give you a hint: Look at the drawings below (Fig. 12) and find the height  $h$ , using similar triangles; once  $h$  is found, you can use the formula for the volume of a frustum of a cone, I gave you before.

(a) Volume of water in the bucket.



(b) A cross-section of the bucket.

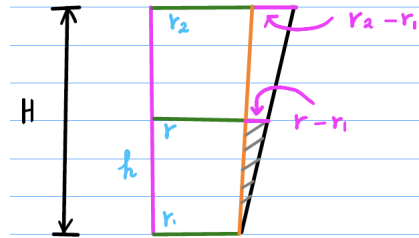


Fig. 12: Finding the height  $h$  using similar triangles.

It is clear that, for this group, the didactical contract has changed and so I intervened and modified the milieu. Due to the time constraint of the project, I reasoned that it would be pedagogically sound to intervene rather than leaving the group frustrated for a long time.

- **Group 3:**

This group managed to find the correct expression of the volume of water in the bucket as a function of the variable height  $h$ :

$$V = \pi \cdot h \cdot \left( r_1^2 + r_1 \cdot \frac{r_2 - r_1}{H} \cdot h + \frac{(r_2 - r_1)^2}{3H^2} \cdot h^2 \right) \quad (5)$$

The group was, however, struggling to differentiate  $V$  with respect to time.

**Teacher:** How do you take the time derivative of  $V$ ?

**Student 3:** We have used CAS to differentiate  $V$  with respect to  $h$ , but we did not get an  $\dot{h}(t)$  as in your equation  $A \cdot \dot{h}(t) = -q_o(t)$ . There is something wrong!

**Teacher:** Which quantity in the equation that is dependent on time.

**Student 4:**  $V$ .

**Teacher:** Only  $V$ ?

**Student 3:** The height is also changing with time.

**Teacher:** Great. What kind of function is  $V$  then?



The group was silent: Composite functions were obviously either forgotten or not even considered. I reminded the group of the definition of a composite function, using the representation shown in Fig. 13 and asked them to search the literature on the chain rule of differentiation in calculus.

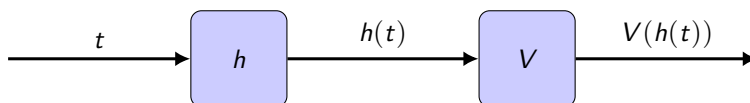


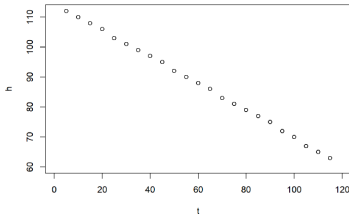
Fig. 13: A representation of a composite function.

I felt that other groups might well have fallen in the trap of the chain rule, and so I decided to post a note on the chain rule for all groups.

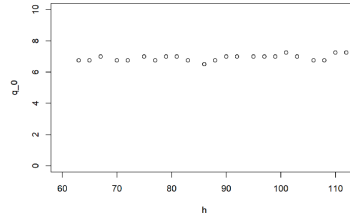
## 5.4 The Formulation Phase

In the formulation phase, the groups were required to present their findings, hypotheses and initial trials. All the group members should take part of the presentation. The group findings and hypotheses must be shared and criticized through class discussions in order to formalize the personal knowledge of each student. Thus, the formulation phase is an invitation for the students to learn from each other, since new knowledge is obtained. Below (Fig. 14) are excerpts from a group presentation in the class.

(a) The measured height as a function of time.

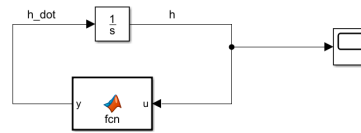


(b) A scatter plot of the outflow rate  $q_o$  vs. the height  $h$ .



$$q_o(h) = 0.005977h + 6.388360$$

(c) A linear relationship between  $q_o$  and  $h$ .



(d) Simulation of the model using Simulink.

Fig. 14: A part of Group 3 presentation.

## 5.5 The Validation Phase

In the validation phase, the groups were required to verify their findings and hypotheses against the milieu. This entailed that they should check if the solution found by Simulink is the same as the water height they measured in the action phase (Fig. 15a and 15b). In practice, this phase was a continuation of the formulation phase and was part of the students' presentations. The solution of the problem was thus validated through the group work itself, not by the teacher telling them whether they are right or wrong.

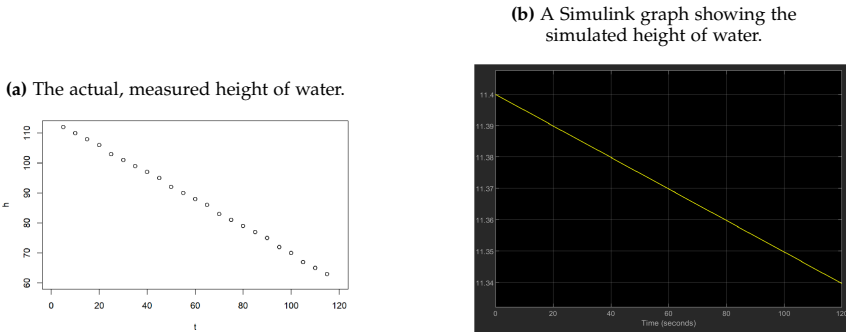


Fig. 15: Comparing the measured height of water with the simulated one.

## 5.6 The Institutionalization Phase

In this phase, the personal knowledge of the students will reach the state of formal, institutionalized knowledge. I build on the students knowledge by presenting the sought engineering knowledge in a concise way as in textbooks [74]:

A flow through a pipe is called laminar if the pressure drop  $\Delta P$  is proportional to the flow rate  $q_o(t)$ :

$$\Delta P = R_L \cdot q_o(t) \quad (6)$$

where  $R_L$  is called the laminar fluid resistance. Since  $\Delta P = \rho \cdot g \cdot h(t)$ , we get

$$q_o(t) = \frac{1}{R_L} \cdot \Delta P \quad (7)$$

$$= \frac{1}{R_L} \cdot \rho \cdot g \cdot h(t) \quad (8)$$

$$= k_1 \cdot h(t) \quad (9)$$

This relation is of the same kind that half the groups arrived at in the action phase.

A flow through a pipe is called turbulent if the pressure drop  $\Delta P$  and the flow rate  $q_o(t)$  satisfy the following relation:

$$\Delta P = R_T \cdot (q_o(t))^2 \quad (10)$$

where  $R_T$  is called the nonlinear (turbulent) fluid resistance. Again, Since

$\Delta P = \rho \cdot g \cdot h(t)$ , we get

$$q_o(t) = \sqrt{\frac{\rho \cdot g \cdot h(t)}{R_T}} \quad (11)$$

$$= \sqrt{\frac{\rho \cdot g}{R_T}} \cdot \sqrt{h(t)} \quad (12)$$

$$= k_2 \cdot \sqrt{h(t)} \quad (13)$$

Once again, this relation is similar to the one that the other half of the groups arrived at in the action phase.

The institutionalization phase was a simple continuation of the student's knowledge regarding the given task. I did not give a lecture in the ordinary sense, but rather a synthesis of the knowledge constructed by the students themselves so that they could relate their personal knowledge to the formal knowledge.

Finally, I presented to the students the steps involved in the mathematical modeling process, together with some figures representing the mathematical modeling cycle.

## 6 Some Issues of Applying TDS in the Course

In a TDS-based mathematics teaching, the students are supposed to start working on a given problem right in the action phase. Here, the students do their own observations of their lack of knowledge, similar to a researcher's first approach to an open problem: The students' initial work might be based on "trial and error" and they may not have an obvious strategy to tackle the problem.

In engineering courses though, the students are presented to laws, techniques, measurements and observations that took scientists and engineers generations to establish. Therefore, it is not always possible for the students to carry out their own measurements, discover the right techniques and laws and do their own observations in all parts of the course. This might be the reason why I took active part in the action phase, together with the students, before devolving the problem in the formulation phase.

Therefore, the action phase in my course could not be a completely adidactical situation, but rather a combination of didactical and didactical situations,

where I introduced some necessary institutionalized knowledge in order to keep students on the right track of the sought knowledge. In fact, TDS itself does not suppose that the student only learns in the action phase. On the contrary, "it even implies that some knowledge can only be transmitted directly during institutionalization." [65, p. 116]

Transferring TDS from mathematics education to engineering education (such as my course) is possible if the teacher can

- find fundamental situations that address some engineering topics for the students to explore, in such a way that they are given the space and time to make their own observations through experiments, and
- get the students to actually ask the right questions to these experiments.

As in a mathematics teaching situation, the engineering students should be allowed to do their own observations of their lack of knowledge and, most importantly, construct their own knowledge of the mathematical modeling process and the simulations of the models, for example.

My students differed in skills and knowledge, and most of them needed a strong guidance to learn. I tried to solve this issue by letting the students work in groups in the action phase, where I was a visiting group member having a double role:

1. I acted more or less like the ancient Greek philosopher Socrates, by asking questions that forced the students to ascertain a fundamental insight in the issue at hand.
2. I gave some institutionalized knowledge according to the needs of the groups visited, to keep the students on the right track.
3. I had to make decisions on the spot, taking into account the different backgrounds of the students while making sure that my teaching project stayed on course.

Having said that, I do not claim that TDS learning situations were fully implemented in the whole course as "such situations, fundamental in learning, can only rarely correspond to the whole of the teaching in a given field under standard conditions, even when such functioning is theoretically possible, simply due to time constraints." [13, p. 15]

The duration of the course and the allocated teacher preparation time for the course were simply not enough to fully implement Inquiry Based Mathematics

Teaching (IBMT), such as TDS. For example, it took much time to prepare cases, design lab experiments and arrange meetings with the workshop personnel and the equipment suppliers, etc.

Even though it is difficult to guarantee that the action phase is purely didactic, I believe that the teacher should nevertheless try to give the students maximum responsibility for finding the solution of a problem.

We have at our disposal a lot of research results on the interaction between students and the milieu in didactic situations, but much less work on the role of the teacher in his or her interaction with the students. Mathematics education "is progressively being acknowledged as a scientific discipline, but within its community it tends to be dealt with as a purely scientific discipline with no connection to the social reality and to the most urgent needs of teachers." [79, p. 2]

In his plenary speech at the ICME 7 conference (Quebec, 1992), Howson [68] expressed something very interesting about this, in that he said "I have written elsewhere of the danger that parts of "mathematics education" will detach themselves from mathematics teaching in much the same way that "philosophy of mathematics" has drifted well away from 'mathematics' itself. (...). The importance of such studies is not to be denied, but where does that leave the mathematics educator who wants to serve and help teachers, not just to study, count, or assess them? Perhaps it would be a useful check for all of us contributing to this congress to ask of our contribution: How will/could it help teachers, under what conditions and within what timescale?"

I believe that the issue raised by Howson emphasizes the disturbing fact that most research in education and didactics are *about* teachers and students but not *for* teachers and students. I also believe that research in education should consider important aspects of the teaching profession, such as

- teachers as decision makers,
- the time constraint of the curriculum imposed on the teachers,
- the knowledge and beliefs of the teachers,
- difference in skills and knowledge of the students, and
- the fact that most students need a strong guidance to learn [59].

## 7 Mathematical Modeling and TDS

TDS is a general theoretical framework in mathematics education, whereas mathematical modeling refers to a specific set of mathematical practices and content. However, Brousseau's student-centered and constructivist approach appeared practical and applicable, and many concepts of his theory seem to have relevance and usability to teaching mathematical modeling at university.

A close look at the students' reports in the course reveals that a *hands-on experience* in mathematical modeling is a key factor in allowing the students to construct their own knowledge of the mathematical modeling cycle.

So, based on my experience in teaching mathematical modeling, using Brousseau's theory, I can identify the following parallels.

1. The mathematical modeling process encourages the students to engage in the problem within a social context [97]. This is called the milieu in Brousseau's theory.
2. Applying mathematics to real-world and authentic problems helps the students understand mathematics conceptually, a view that is consistent with Brousseau's constructivism and specifically with his sharp distinction between didactical and adidactical problems.
3. The obstacles and difficulties that my students encountered when confronted with the modeling of the fluid system are closely related to the mutual expectations of the students and the teacher. This is precisely what Brousseau calls the didactical contract: The implicit agreement between the students and the teacher, given that the contract is subject to renegotiation. Modeling problems challenge those expectations, as, for example, when the students expect the teacher to show them the *right* answer to a problem.
4. The students' learning experience of a real-life situation provides them with an independent basis to evaluate a mathematical solution [54]. This is the essence of Brousseau's validation phase: Students realize that the solution of the problem lies in their hands, rather than being based on the teacher's officially correct opinion.
5. Brousseau placed adidactical situations at the heart of his teaching, distinguishing them from didactical situations, which are only relevant at school. This is analogous to what modeling researchers call authenticity [52]. In fact, researchers allocate at least two meanings in describing

*authentic models*. On the one hand, authenticity denotes genuineness and originality; on the other hand, authenticity refers to simulation activities of out-of-school aspects of mathematics [105]. Both meanings are compatible with the crucial role didactical situations play in Brousseau’s theory.

6. According to Brousseau, the meaning of mathematics derives from the context in which it is utilized. Similarly, the modeling cycle starts with a situation in a real-world context and the students must identify salient features of the problem and mathematize them.
7. Brousseau distinguished two types of knowledge by which students may understand a mathematical concept: *connaissance* and *savoir* [30, p. 131]. The modeling literature contains a similar distinction between conceptual understanding and procedural fluency. For example, Pollak [92] explained the benefits of teaching mathematics as a process rather than emphasizing getting the right answer.

Based on the above considerations, I can now characterize the analogies between TDS phases and the stages of the mathematical modeling cycle, together with their implementations in the course case study (Table 1).

**Table 1:** Analogies of TDS phases with the stages of the modeling cycle.

TDS Phase	Modeling Cycle Stage	Implementation
Devolution	Real-word problem	Fluid system modeling
Action	Formulation and solution	Measurements and simulation
Formulation	Presenting the solution	Group presentations
Validation	Validating the solution	Measured height vs. simulated height
Institutionalization	Reporting the conclusion	Rigorous presentation of fluid flow

It is perhaps interesting to know that, in addition to his duties as a teacher, Brousseau worked with local farmers in 1962 to help them optimize their production by applying mathematics, and thus gained practical experience in real mathematical modeling [29]. He considered the need for more real life problems in mathematics education an important cultural movement ([29], p. 241) that would require study through the application of the methods of the theory of didactical situations.

A well-prepared modeling problem can evoke a mathematical concept and learning through modeling is facilitated by the students’ personal experiences



with the real-world context of the problem. This is in fact the key advantage of modeling problems: Modeling effectively develops a conceptual understanding of both mathematics and engineering science, because the students have their personal experiences to draw on. The real world of the classroom and the workshop, the milieu, is a particularly effective context in which to situate problems. The students would therefore actively engage in solving real-world problems because they realize that the problems make sense to them.

## 8 Mathematical Modeling and other Theoretical Perspectives

In this section, I will elaborate on the relation between mathematical modeling and two other prominent programs in mathematics education research, along with TDS. The first is Realistic Mathematics Education, founded by Hans Freudental in Holland and the other is the Anthropological Theory of Didactics (ATD), initiated by Yves Chavallard in France.

Both are general theoretical approaches and explicitly use the notion of mathematical modeling.

I will argue that, in both approaches, mathematical modeling is *the* driving force of the didactics of engineering mathematics.

### 8.1 Realistic Mathematics Education

According to Realistic Mathematics Education (RME), mathematics is a human activity. New meaning of mathematics for a learner is not drawn from the formal mathematical structure, but rather from what is real and meaningful for the learner. The learning activities of the students should involve *non-mathematical* contexts in order to allow them to acquire new knowledge from what already makes sense to them.

"What is real is mutually connected by actual, imagined and symbolized relations (...) which can extend from the nucleus of everyday life experience to the far frontiers of mathematical research." [51, p. 30]

Formal presentation of mathematics is thus rather inaccessible for novice learners, since meaning and motivation are taken away from the students and the natural process of curiosity in arriving at the mathematics is not shown.

In the terminology of RME, it is an *anti-didactical inversion* [51].

For example, starting with the formal  $\epsilon$ - $\delta$  definition of limits in introducing the the students to the theory of limits in the first year of their studies, or in the secondary school does not make sense to the students, since they have no understanding yet of rigorous proofs, not to mention why other definitions did not work.

In my paper B: "Teaching the Limits of Functions Using the Theory of Didactical Situations and Problem-Based Learning", I showed how to enable engineering students arrive at the formal definition of limits themselves, through realistic contexts that they are familiar with.

One of the main tenets of Realistic Mathematics Education (RME) is *mathematizing*, which can include axiomatizing, formalizing and modeling:

"Mathematizing is the entire organizing activity of the mathematician, whether it affects mathematical content and expression, or more naive, intuitive, say lived experience, expressed in everyday language." [51, p. 31]

There are two distinct directions in mathematizing: horizontal and vertical [103]. Horizontal mathematizing is the translation of a problem or situation into a mathematical language. It enables describing and analyzing the problem through mathematization. Vertical mathematizing is doing mathematics within mathematics itself.

RME advocates the tight bonds of mathematics with reality:

"The world is noisy; mathematizing the world means looking for essentials, sensing the message within the noise. This, too, has to be learned, that is, reinvented by the learner, and the earlier the better; once the learner has fully been indoctrinated by ready-made schemes and algorithms it may be too late." [51, p. 81]

This statement has strong similarities with the fact that the first step of the mathematical modeling process is to decide which features of the real world to keep and which to disregard, much like a filter that, completely or partially, suppresses unwanted features, like noise, from a signal.

Mathematical modeling is more than applying mathematics, where one starts with a real-world problem and apply the necessary mathematics: It is also posing questions. The use of mathematics in modeling is more than understanding the real-world problem situation: It is also a vehicle to to pose questions, as well as teaching and learning mathematical concepts and proce-

dures [76].

Therefore mathematical modeling as a didactic principle to teaching engineering mathematics is fully compatible with RME's horizontal and vertical mathematizing. As Freudental himself puts it:

"In its first principles, mathematics means mathematizing reality." [50, p. 7]

Thus, in my paper D: "Integrating the Methods of Mathematical Modeling and Engineering Design in Projects", I used mathematical modeling as a method to introduce differential equations.

## 8.2 The Anthropological Theory of Didactics Revisited

In section 2.5, I gave a short introduction to the Anthropological Theory of Didactics (ATD) as a major program of research in mathematics education. Here I will show that ATD too has an epistemological perspective on mathematical modeling.

In fact, ATD puts mathematical modeling at the heart of the learning of mathematics, emphasizing that modeling *is* a didactical means for learning mathematics rather than just modeling competency as an aim. As a matter of fact, according to many ATD researchers, mathematical modeling is not another branch of mathematics, but rather "mathematical activity is essentially modeling activity in itself" [56, p. 232]. This claim does make sense if mathematical modeling involves modeling of real-world situations as well as problems related to pure mathematics. This view is in harmony with RME's main concepts of horizontal and vertical mathematizing.

One consequence of using modeling from the ATD perspective is that it "leads to the fact that every mathematical activity is identified as modeling activity for which modeling is not limited to mathematizing of non-mathematical issues." [99, p. 45]

According to ATD, one of the roles of the instructor is to organize the teaching situations around a series of so-called generative questions, the answers of which, will lead to the mathematical knowledge in the curriculum. A strong generative question  $Q_0$  is an open question that will lead to derived sub-questions  $Q_1$ ,  $Q_2$ , etc. The totality of the answers to the sub-questions constitutes an answer for the generating question  $Q_0$ .

A generative question should be meaningful to the students. It is "a question with enough *generative power*, in the sense that the work done on it by the

group is bound to engender a rich succession of problems that they will have to solve -at least partially- in order to reach a valuable answer to the question studied." [35, p. 7-8]

The didactical research in ATD concentrates on developing and implementing what is called study and research path (SRP), organized around such questions [36].

SRP is a design tool where teaching is based on an open question, which is supposed to initiate a study and research process, just like a PBL teaching situation starts with an open problem that will gradually guide the students to acquire the sought knowledge.

One can also find similarities between these generative questions and the didactical situations in Realistic Mathematics Education (RME), where new knowledge is developed from what is already meaningful for the students. The concept of a generative question is also closely related to that of a fundamental situation in TDS, given that a fundamental situation is a reformulation of a mathematical knowledge, using problems and questions for which that knowledge is an answer

In addition, I claim that a generative question corresponds to a problem in PBL, since the later is not about problem solving per se, but rather it uses appropriate problems to increase knowledge and understanding. For example, in my paper: "A Problem-Based Approach to Teaching a Course in Engineering Mechanics", I started my first teaching session in the course by showing the students a figure that represents a situation, they are familiar with (Fig. 16), and asking "Why doesn't the girl fall on the ground?"



**Fig. 16:** A girl on a swing.

This question generated a series of questions about forces and equilibrium, which, in turn, generated another series of questions about strength of materials, safety and the selection of materials. Thus, all the major topics of the course were triggered by a single generative question. Upon reflecting on what I did in the course, I realized now that I, unconsciously, used an ATD's study and research path in planning the course, even though I had PBL implementation in mind.

Regarding modeling activities, ATD also emphasizes the crucial role of generative questions: "the modeling activity is a process of reconstruction and articulation of mathematical praxeologies which become progressively broader and more complex. That process starts from the consideration of a (mathematical or extra-mathematical) problematic question that constitutes the rationale of the mathematical models that are being constructed and integrated." [17, p. 2051]

It seems therefore that the modeling from the perspective of ATD is compatible with the mathematical modeling cycle [56]. Moreover, the generative questions in ATD are similar to a famous characterization of modeling: "Here is a situation—think about it." [92]

The Anthropological Theory of Didactics shares the main view of Realistic Mathematics Education (RME): Mathematics is a human activity that is closely related to real-life problems, no matter how remote it may seem from reality. Thus, "it appears that Chevallard's anthropological theory, as it stands today, is fully consistent with the basic tenets of Freudenthal's program: to view and to teach mathematics as (primarily) a set of tools to solve real human challenges, rather than as a kind of fine art or independent reality, whose utility and origins have long been forgotten." [108, p. 2]

## 9 The Didactical Modeling Cycle

Throughout history, education researchers have devised models that seek to identify and characterize important elements of teaching and learning, both at general and domain-specific levels. These models help us concentrate on critical components and processes that need to be understood and analyzed, when designing curricula, in the planning of lessons or in assessing educational practices. I refer to these types of models as *didactical models*. In my papers, I analyzed and discussed the relevance and usability of some of these models for courses in mathematics and engineering science.

Even though didactical models are often used implicitly by educators, I tried to make them more *explicit* in my papers, in order to facilitate the understanding of the practices that they support, and to trigger reflection on their potential restrictions and the constraints they may impose on teaching and learning.

To cope with the diversity of these models, I propose a *meta-model* that, on the one hand, acknowledges the richness of these models, and on the other hand, aims at a further development of them, by considering their meaning for practically oriented empirical research.

The purpose of this section is to introduce the Didactical Modeling Cycle (DMC) as an applied design methodology in engineering education. I claim that DMC articulates a mixture of construction/inquiry and transmission of knowledge to achieve teaching that locally optimizes learning. I compare the methodology with other approaches and argue that DMC has some advantages and merits. I explain why I think it is useful to follow this approach in both education research and in its application in the classroom. A visual illustration of the didactical modeling cycle is shown in Fig. 17.

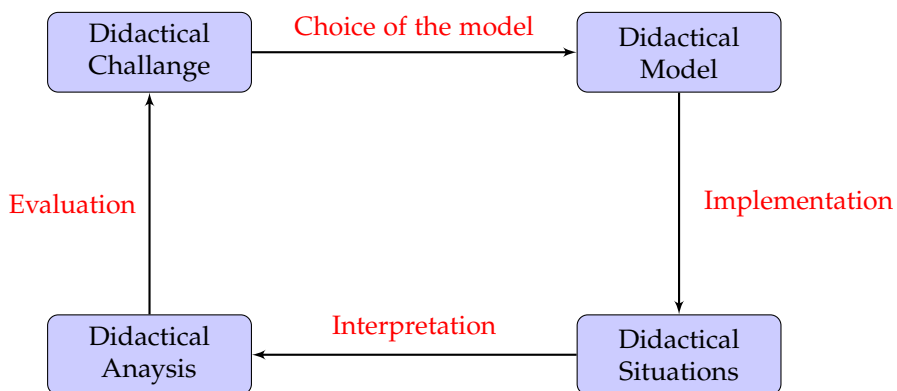


Fig. 17: The didactical modeling cycle.

Like the mathematical modeling process, my teaching methodology starts with a didactical challenge in an educational context and then develops questions about it. These questions should be answered by using established didactical tools and existing research on the topic in question.

As examples of didactical challenges, I can mention

- Teaching engineering students to apply a mathematical theory in real-world situations.

- The apparent incongruity between the intentions of the official curriculum of a course or a study program and how instructors actually implement the curriculum in the classroom.
- The discrepancy between the concept of a vector as taught at the upper secondary school and its various uses in engineering science courses, such as mechanics and strength of materials.

The *a priori* analysis of the didactical challenge will lead to a formulation of a list of possible didactical models and the choice of one model as a starting point. In my papers, for example, I have chosen the following models

- Problem-Based Learning
- Theory of Didactical Situations
- Variation Theory
- Inquiry-Based Learning
- Teacher-led learning through worked examples

The choice of the above-mentioned models was triggered by many factors such as the various backgrounds of the students, the didactical analysis of the challenges expected in teaching a course or a topic and the time and syllabus constraints imposed on me as an instructor.

As an application of the didactic modeling cycle, I can mention my paper E: "Inquiry-Based Teaching in Engineering: The Case of 'transfer functions'". In that paper, I have used all the steps in Fig. 17, without explicitly mentioning the cycle itself.

I regard engineering education as an applied design science, that is used to solve practical challenges in the class room in order to improve teaching and learning of engineering mathematics and engineering sciences and to *reflect* on the impact it would have on the research in engineering education.

By the same token, research in engineering education is *similar* to the engineering profession itself: Engineering does not only involve the design and development of products, but *also* the design process that leads to these products.

"The parallels between engineering design and education design begin with the nature of the systems where the products of design are used. The systems are not fixed even if they are often stable. The systems require innovation, respond to innovation (e.g., a curriculum, a piece of technology), and are changed by innovation." [77]

Engineers must be able to describe and analyze objects and devices in order to predict their behavior and to see if that behavior is what they expect. Thus, engineers need to *model* systems and processes if they are going to design those systems and processes.

As argued in my paper D: "Integrating the Methods of Mathematical Modeling and Engineering Design in Projects", the engineering design process and the mathematical modeling processes are *inseparable* in practice: Altering the design of an object or a system will eventually lead to a change in its mathematical model and vice versa. Thus, the aim of the two processes is the same: The creation of a product or system that should meet given requirements, technical and non-technical.

Similar to the work of an engineer, an instructor should also be able to analyze and design teaching situations and perform evaluations to see if the teaching outcomes satisfy the curriculum requirements *and* result in new knowledge for the students.

An engineer, being a problem solver, applies acknowledged theories, advanced by scientists, to practical problems in society. Meanwhile, he or she may discover a "local" empirical law that may model the problem better, for example modeling the erratic behavior of a spring in a mechanical system, that the physicist may not be interested in. This could be due to the fact that an engineer is required to solve complex problems for society. These problems can have many aspects, technical, economical and societal, that should be accounted for.

Similarly, an instructor, facing a didactical challenge, may use an off-the-shelf didactical model in an attempt to solve the problem and may also make "on-the-spot" decisions in the class room. In the eternal struggle between "theory" and "practice", he or she would modify the theory so that it will be rendered applicable to the specific situation, or even discover his or her own "local" theory, that may better describe the complex didactic situation in the classroom.

"Teachers exhibit the same characteristics in solving problems of instruction that are employed by problem solvers in other contexts. Just as behaviorist analyses of problem solving proved to be inadequate to capture the complexity of the problem-solving process, viewing teachers simply as actors who exhibit certain behaviors is severely limiting. They do not blindly follow lesson plans in teachers' manuals or prescriptions for effective teaching. They interpret them in terms of their own constructs and adapt them to fit the situation as they perceive it" [32].



It is not the purpose of DMC to theorize about some aspect of the teaching process but, rather, it is directed towards changing something in the teaching of a course or a topic. Through DMC, instructors and researchers are given the opportunity to work together on improving or changing a didactical model so that it works better for its purposes. Thus, my approach attempts to make these two worlds meet in order to bridge the gap between the teaching practice and the research practice. Therefore, educational research will also be *with* and *for* the instructors and not only *about* them.

The Didactical Modeling Cycle (DMC) can be regarded as a logical extension of design-based research (DBR) in the same sense as the modeling process is a continuation of the engineering design process: The product to be designed is also *modeled* using basic sciences, mathematics and engineering sciences to convert resources optimally to meet a stated objective.

The three methods, Didactical Engineering (DE), Design-Based Research (DBR) and the Didactical Modeling Cycle (DMC), all seek to mediate between theory and practice, with some kind of cooperation between education researchers and practitioners. They all rely on empirical experimenting with educational settings in order to reach their research objectives. DMC differs from the other approaches in that it specifically employs the modeling cycle, allowing the instructor to gain an understanding of the whole didactical system for the purpose of improving it.

Table 2 shows the main similarities and differences between the three approaches as a brief summary.

**Table 2:** A comparison of Didactical Engineering (DE), Design-Based Research (DBR) and the Didactical Modeling Cycle (DMC).

Issue	DE	DBR	DMC
<b>Theoretical assumptions</b>	The TDS or ATD is the guiding platform	Theories emerge from the data	Any research-based model
<b>Research approach</b>	A noncyclic approach concerning controlled organization of teaching experiments	Iterative cycles of design, testing, analysis and redesign	A cyclic process that can lead to revising the didactical model
<b>Empirical research</b>	Testing in a classroom	Testing in a classroom	Testing in a classroom
<b>Evaluation</b>	Only internal	Internal and external	Internal and external
<b>Product</b>	Identifying and producing didactical phenomena	Developing didactical solutions	Producing a didactical model as a response to a didactical challenge

## 10 Conclusion

The complex reality of teaching and learning could be one of the reasons behind the large diversity of theoretical frameworks. These theoretical frameworks should not be conceived as norms to follow, but as tentative models that evolve and are subject to modification according to their success in explaining didactic phenomena.

However, this diversity may pose at least two challenges for educators and instructors:

- Researchers from different theoretical frameworks in mathematics and engineering sometimes have difficulties understanding each other in depth because of their different backgrounds, languages and implicit assumptions. This would make it difficult for the instructor to interpret and implement the didactical model in concrete teaching situations.

- Researchers with different theoretical perspectives consider empirical phenomena from different perspectives and hence come to very different results in their empirical studies, similar to the well-known fable *the blind men and an elephant*<sup>6</sup>, illustrated in Fig. 18. Again, integrating the results from different studies and understanding their differences are not easy tasks for the instructor.

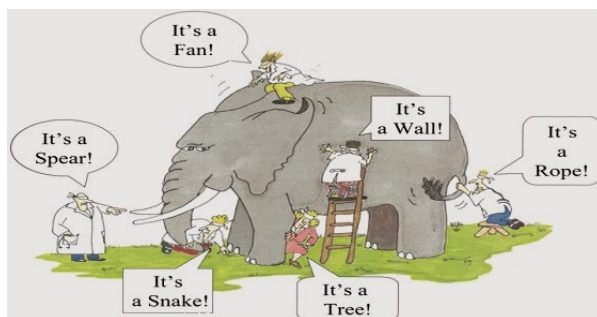


Fig. 18: The blind men and the elephant.

The teaching process is a complex activity involving "the proactive role of the teacher in establishing an appropriate classroom culture, in choosing and introducing instructional tasks, organizing group work, framing topics for discussion and orchestrating discussion." [61]

My didactical modeling cycle allocates a leading role for the instructor in orchestrating the design, analysis and evaluation of the didactical situations in a rapidly changing learning landscape, shaped by fast societal and technological developments.

Instructors have the responsibility of creating learning environments that allow the students to build up understanding and acquire new knowledge, *and* also to make hypotheses about and experimentation with relevant didactical models in order to initiate a change in the students' conceptual constructs.

In general, models describe our beliefs about how the world functions. Without realizing it, we all use mental models in our daily life. In its widest definition, any theory that helps us understand something is considered a mental model. Moreover, comparing and contrasting models can contribute to improve them.

---

<sup>6</sup>The blind men and an elephant is a story of a group of blind men who have never met an elephant before, and who conceptualize what the elephant is like by touching it. The moral of the story is the need for communication and the respect for different perspectives.

In didactical modeling, we translate those beliefs into a theoretical educational framework, which is an organized system of accepted knowledge that applies in a variety of circumstances to explain a specific set of phenomena.

The purpose of didactical models is not to fit the data in the classroom but to sharpen the questions raised by a didactical challenge and try to answer them.

In 1976, the British statistician George Box (1919-2013) wrote the famous line, "All models are wrong, some are useful." [26]

His point was that we should focus more on whether something can be applied to everyday life in a useful manner rather than debating endlessly if a method or theory is correct in all cases. Similarly, didactical models are approximations of the reality in the classroom and the constraints imposed on the instructor. If we *combine* these models, we have a strategy that can help us take action at various stages in a didactical situation.

For a pure scientist, the ultimate cognitive value of a theory is theoretical truth. This is in contrast to an engineering scientist, where the ultimate cognitive value of a theory or model is its practical usability. Thus, the real test of an educational theory is not truth but utility, since the theory should be "engineered" by the instructor and implemented in the class room.

A didactical model gives the instructor power. The more useful that power, the better the model. As instructors, we should always search for better answers, look for evidence and strive to increase the scope of our knowledge.

"Just as teachers may have things to learn about the limitations of their existing practice, and the merits of the research-based proposals, so equally the researchers will have things to learn about the limitations of the proposals (and of the research), and about the merits of teachers' existing practices." [85, p. 366]

I claim that teaching practices are so complex that researchers do not always incorporate the economy of ordinary practices in their research in a sufficient way, that is, the instructors' struggle to balance the various professional constraints under which they work and the degree of freedom they have. For me, the clarification and understanding of ordinary classroom practices are crucial issues and essential steps towards the integration of the two worlds: didactical research in engineering and its practice.

## References

- [1] M. Achiam, L. Simony, and B. E. K. Lindow, "Objects prompt authentic scientific activities among learners in a museum programme," *International Journal of Science Education*, vol. 38, no. 6, pp. 1012–1035, 2016.
- [2] T. Anderson and J. Shattuck, "Design-based research: A decade of progress in education research?" *Educational researcher*, vol. 41, no. 1, pp. 16–25, 2012.
- [3] G. B. Arfken and H. J. Weber, "Mathematical methods for physicists," 1999.
- [4] A. Arseven, "Mathematical modelling approach in mathematics education." *Universal Journal of Educational Research*, vol. 3, no. 12, pp. 973–980, 2015.
- [5] M. Artigue, "Didactic engineering and the complexity of learning processes in classroom situations," in *Proceedings of the MADIF 2 Conference*, 2000, pp. 5–20.
- [6] M. Artigue, M. Bosch, J. Gascón, and A. Lenfant, "Research problems emerging from a teaching episode: a dialogue between tds and atd," in *Proceedings of the sixth congress of the European society for research in mathematics education*, 2010, pp. 1535–1544.
- [7] M. Artigue, "Ingénierie didactique," *Recherches en didactique des mathématiques*, vol. 9, no. 3, pp. 281–308, 1988.
- [8] —, "L'ingénierie didactique: un essai de synthèse," *En amont et en aval des ingénieries didactiques*, pp. 225–237, 2011.
- [9] —, "Perspectives on design research: the case of didactical engineering," in *Approaches to qualitative research in mathematics education*. Springer, 2015, pp. 467–496.
- [10] M. Artigue and P. Baptist, "Inquiry in mathematics education (resources for implementing inquiry in science and in mathematics at school)," *Dostupné z <http://www.fibonacci-project.eu>*, 2012.
- [11] M. Artigue, M. Bartolini-Bussi, T. Dreyfus, E. Gray, S. Prediger *et al.*, "Different theoretical perspectives and approaches in research in mathematics education," in *Proceedings of the 4th congress of the European society for research in mathematics education, Sant Feliu de Guixols, Spain: Fundemi IQS*, 2006, pp. 1239–1244.
- [12] M. Artigue and M. Blomhøj, "Conceptualizing inquiry-based education in mathematics," *ZDM*, vol. 45, no. 6, pp. 797–810, 2013.
- [13] M. Artigue and M.-J. Perrin-Glorian, "Didactic engineering, research and development tool: some theoretical problems linked to this duality," *For the learning of Mathematics*, vol. 11, no. 1, pp. 13–18, 1991.
- [14] F. Arzarello, M. Bosch, A. Lenfant, and S. Prediger, "Different theoretical perspectives in research introduction to the papers of working group 11," in *Proceedings of CERME*, vol. 5, 2007, pp. 1–10.
- [15] D. E. Avison, F. Lau, M. D. Myers, and P. A. Nielsen, "Action research," *Commun. ACM*, vol. 42, no. 1, p. 9497, Jan. 1999. [Online]. Available: <https://doi.org/10.1145/291469.291479>

- [16] A. Bakker and D. Van Eerde, "An introduction to design-based research with an example from statistics education," in *Approaches to qualitative research in mathematics education*. Springer, 2015, pp. 429–466.
- [17] B. Barquero, M. Bosch, and J. Gascón, "Using research and study courses for teaching mathematical modelling at university level," in *Proceedings of the fifth congress of the European society for research in mathematics education*, 2008, pp. 2050–2059.
- [18] J. Biggs, "Enhancing teaching through constructive alignment," *Higher education*, vol. 32, no. 3, pp. 347–364, 1996.
- [19] M. Blomhøj and T. H. Jensen, "Developing mathematical modelling competence: Conceptual clarification and educational planning," *Teaching mathematics and its applications*, vol. 22, no. 3, pp. 123–139, 2003.
- [20] —, "Whats all the fuss about competencies?" in *Modelling and applications in mathematics education*. Springer, 2007, pp. 45–56.
- [21] M. Blomhøj and T. H. Kjeldsen, "Teaching mathematical modelling through project work," *ZDM*, vol. 38, no. 2, pp. 163–177, 2006.
- [22] W. Blum, "Mathematical modelling in mathematics education and instruction," 1993.
- [23] —, "Quality teaching of mathematical modelling: What do we know, what can we do?" in *The proceedings of the 12th international congress on mathematical education*. Springer, Cham, 2015, pp. 73–96.
- [24] W. Blum, D. Burghes, N. Green, and G. Kaiser-Messmer, "Teaching and learning of mathematics and its applications: first results from a comparative empirical study in england and germany," *Teaching Mathematics and its Applications: An International Journal of the IMA*, vol. 11, no. 3, pp. 112–123, 1992.
- [25] W. Blum and M. Niss, "Mathematical problem solving, modelling, applications, and links to other subjects," 1989.
- [26] G. E. Box, "Science and statistics," *Journal of the American Statistical Association*, vol. 71, no. 356, pp. 791–799, 1976.
- [27] G. Brousseau, "Theory of didactical situations in mathematics," 01 1997.
- [28] —, "Fondements et méthodes de la didactique des mathématiques," *Recherches en didactique des mathématiques (Revue)*, vol. 7, no. 2, pp. 33–115, 1986.
- [29] —, *Theory of didactical situations in mathematics: Didactique des mathématiques, 1970–1990*. Springer Science & Business Media, 2006, vol. 19.
- [30] G. Brousseau, N. Brousseau, and V. Warfield, *Teaching fractions through situations: A fundamental experiment*. Springer, 2013, vol. 54.
- [31] G. Brousseau, B. Sarrazy, and J. Novotná, "Didactic contract in mathematics education," *Encyclopedia of mathematics education*, pp. 153–159, 2014.
- [32] T. P. Carpenter, E. Fennema, P. L. Peterson, and D. A. Carey, "Teachers' pedagogical content knowledge of students' problem solving in elementary arithmetic," *Journal for research in mathematics education*, pp. 385–401, 1988.

- [33] Y. Chevallard, "Fundamental concepts in didactics: perspectives provided by an anthropological approach," *Research in didactique of mathematics: Selected papers*, pp. 131–168, 1992.
- [34] —, "Steps towards a new epistemology in mathematics education," in *Proceedings of the 4th Conference of the European Society for Research in Mathematics Education (CERME 4)*, 2006, pp. 21–30.
- [35] —, "Readjusting didactics to a changing epistemology," *European Educational Research Journal*, vol. 6, no. 2, pp. 131–134, 2007.
- [36] —, "La notion dingénierie didactique, un concept à refonder. questionnement et éléments de réponse à partir de la tad," *En amont et en aval des ingénieries didactiques*, pp. 81–108, 2011.
- [37] F. V. Christiansen and L. Olsen, "Analysis and design of didactic situations: a pharmaceutical example," 2006.
- [38] P. Cobb, J. Confrey, A. DiSessa, R. Lehrer, and L. Schauble, "Design experiments in educational research," *Educational researcher*, vol. 32, no. 1, pp. 9–13, 2003.
- [39] P. Cobb and K. Gravemeijer, "Experimenting to support and understand learning processes," *Handbook of design research methods in education: Innovations in science, technology, engineering, and mathematics learning and teaching*, pp. 68–95, 2008.
- [40] D.-B. R. Collective, "Design-based research: An emerging paradigm for educational inquiry," *Educational Researcher*, vol. 32, no. 1, pp. 5–8, 2003.
- [41] A. Collins, D. Joseph, and K. Bielaczyc, "Design research: Theoretical and methodological issues," *The Journal of the learning sciences*, vol. 13, no. 1, pp. 15–42, 2004.
- [42] J. W. Creswell and J. D. Creswell, *Research design: Qualitative, quantitative, and mixed methods approaches*. Sage publications, 2017.
- [43] E. De Graaf and A. Kolmos, "Characteristics of problem-based learning," *International Journal of Engineering Education*, vol. 19, no. 5, pp. 657–662, 2003.
- [44] P. Dirac, "The principles of quantum mechanics, 4th edn. clarendon," 1958.
- [45] A. A. DiSessa and P. Cobb, "Ontological innovation and the role of theory in design experiments," *The journal of the learning sciences*, vol. 13, no. 1, pp. 77–103, 2004.
- [46] D. Edwards, "Guide to mathematical modelling palgrave," *Institute of Mathematics and its Applications*, vol. 19, 2000.
- [47] D. C. Ernst, A. Hodge, and S. Yoshinobu, "What is inquiry-based learning," *Notices of the AMS*, vol. 64, no. 6, pp. 570–574, 2017.
- [48] R. Evans and C. Winsløw, "Fundamental situations in teaching biology: The case of parthenogenesis," *Nordic Studies in Science Education*, vol. 3, no. 2, pp. 132–145, 2007.
- [49] R. B. Ferri, "Theoretical and empirical differentiations of phases in the modelling process," *ZDM*, vol. 38, no. 2, pp. 86–95, 2006.
- [50] H. Freudenthal, "Why to teach mathematics so as to be useful," *Educational studies in mathematics*, vol. 1, no. 1-2, pp. 3–8, 1968.

- [51] ———, *Revisiting mathematics education: China lectures*. Springer Science & Business Media, 2006, vol. 9.
- [52] P. Galbraith, “Authenticity and goaloverview,” in *Modelling and applications in mathematics education*. Springer, 2007, pp. 181–184.
- [53] P. Galbraith and G. Stillman, “A framework for identifying student blockages during transitions in the modelling process,” *ZDM*, vol. 38, no. 2, pp. 143–162, 2006.
- [54] P. L. Galbraith, H.-W. Henn, and M. Niss, *Modelling and applications in mathematics education: the 14th ICMI study*. Springer Science & Business Media, 2007, vol. 10.
- [55] G. Galilei, “The assayer (s. drake, trans.),” *Discoveries and opinions of Galileo*, pp. 237–238, 1957.
- [56] F. J. Garcia, J. G. Pérez, L. R. Higuera, and M. B. Casabó, “Mathematical modelling as a tool for the connection of school mathematics,” *ZDM*, vol. 38, no. 3, pp. 226–246, 2006.
- [57] I. M. Gel’fand and G. E. Shilov, *Generalized Functions, Volume 2: Spaces of Fundamental and Generalized Functions*. American Mathematical Soc., 2016, vol. 261.
- [58] B. G. Glaser and A. L. Strauss, *Discovery of grounded theory: Strategies for qualitative research*. Routledge, 2017.
- [59] J. D. Godino, C. Batanero, G. R. Cañadas, and J. M. Contreras, “Linking inquiry and transmission in teaching and learning mathematics and experimental sciences,” *Acta Scientiae*, vol. 18, no. 4, 2016.
- [60] H. T. Gould, “Teachers’ conceptions of mathematical modeling,” Ph.D. dissertation, Columbia University, 2013.
- [61] K. Gravemeijer, “Local instruction theories as means of support for teachers in reform mathematics education,” *Mathematical thinking and learning*, vol. 6, no. 2, pp. 105–128, 2004.
- [62] K. Hara, “Quantitative and qualitative research approaches in education,” *Education*, vol. 115, no. 3, pp. 351–356, 1995.
- [63] S. I. Hayakawa, “Language in thought and action.” *The Florida English Journal*, vol. 3, no. 2, pp. 1–12, 1967.
- [64] V. F. Hendricks, A. Jakobsen, and S. A. Pedersen, “Identification of matrices in science and engineering,” *Journal for General Philosophy of Science*, vol. 31, no. 2, pp. 277–305, 2000.
- [65] M. Hersant and M.-J. Perrin-Glorian, “Characterization of an ordinary teaching practice with the help of the theory of didactic situations,” in *Beyond the apparent banality of the mathematics classroom*. Springer, 2005, pp. 113–151.
- [66] G. S. Hine, “The importance of action research in teacher education programs,” 2013.
- [67] M. Hjalmarson and R. Lesh, “Design research. engineering, systems, products, and processes for innovation,” *Handbook of international research in mathematics education*, vol. 2, 2008.



- [68] G. Howson, "Teachers of mathematics," in *proc. ICME 7*, C. Gaulin, B. R. Hodgson, D. H. Wheeler, and J. C. Egsgard, Eds. Les Presses de L'Université de Laval, 1992, pp. 9–25.
- [69] B. E. Jessen, "How to generate autonomous questioning in secondary mathematics teaching?" *Recherches En Didactique Des Mathematiques*, vol. 37, no. 2/3), pp. 217–245, 2017.
- [70] L. Jianping, L. Minrong, W. Jinnan, L. Jianjian, S. Hongwen, and H. Maoxing, "Global environmental issues and human wellbeing," in *Report on Global Environmental Competitiveness (2013)*. Springer, 2014, pp. 3–21.
- [71] G. Kaiser, "Modelling and modelling competencies in school," *Mathematical modelling (ICTMA 12): Education, engineering and economics*, pp. 110–119, 2007.
- [72] A. E. Kelly, R. A. Lesh, and J. Y. Baek, *Handbook of design research methods in education: Innovations in science, technology, engineering, and mathematics learning and teaching*. Routledge, 2014.
- [73] T. King, "Development of student skills in reflective writing," in *Proceedings of the 4th world conference of the international consortium for educational development in higher education*, 2002, pp. 3–6.
- [74] C. A. Kluever, *Dynamic Systems: Modeling, Simulation, and Control*. Wiley, 2015.
- [75] S. Kvale, *Interviews: An introduction to qualitative research interviewing*. Sage Publications, Inc, 1994.
- [76] J. Lamb and J. Visnovska, "Developing statistical numeracy: The model must make sense," in *Mathematical Modelling in Education Research and Practice*. Springer, 2015, pp. 363–373.
- [77] R. A. Lesh and M. A. Hjalmarson, "Engineering and design research: Intersections for education research and design," in *Handbook of Design Research Methods in Education*. Routledge, 2014, pp. 114–128.
- [78] R. E. Lesh and H. M. Doerr, *Beyond constructivism: Models and modeling perspectives on mathematics problem solving, learning, and teaching*. Lawrence Erlbaum Associates Publishers, 2003.
- [79] N. A. Malara and R. Zan, "The problematic relationship between theory and practice," *Handbook of international research in mathematics education*, pp. 553–580, 2002.
- [80] F. Marton, *Necessary conditions of learning*. Routledge, 2014.
- [81] F. Marton and S. A. Booth, *Learning and awareness*. Psychology Press, 1997.
- [82] F. Marton and M. F. Pang, "The idea of phenomenography and the pedagogy of conceptual change," *International handbook of research on conceptual change*, 2008.
- [83] —, "Meanings are acquired from experiencing differences against a background of sameness, rather than from experiencing sameness against a background of difference: Putting a conjecture to the test by embedding it in a pedagogical tool." *Frontline Learning Research*, vol. 1, no. 1, pp. 24–41, 2013.
- [84] R. E. Mayer, "Should there be a three-strikes rule against pure discovery learning?" *American psychologist*, vol. 59, no. 1, p. 14, 2004.

- [85] D. McIntyre, "Bridging the gap between research and practice," *Cambridge Journal of education*, vol. 35, no. 3, pp. 357–382, 2005.
- [86] H. S. Midtby and L. Ahrenkiel, "Digitale læremidlers potentiale til at støtte udviklingen af matematiske kompetencer," *MONA-Matematik-og Naturfagsdidaktik*, no. 3, 2015.
- [87] K. Ogata, *System dynamics*. Prentice Hall Upper Saddle River, NJ, 1998, vol. 3.
- [88] J. T. Ottesen, "Do not ask what mathematics can do for modelling," in *The teaching and learning of mathematics at university level*. Springer, 2001, pp. 335–346.
- [89] J. Perrenet and B. Zwaneveld, "The many faces of the mathematical modeling cycle," *Journal of Mathematical Modelling and Application*, vol. JMMA, pp. 3–21, 06 2012.
- [90] M.-J. Perrin-Glorian, "Didactic engineering 'a interface between research and teaching. resource development and teacher training," *Upstream and downstream of didactic engineering*, pp. 57–78, 2011.
- [91] J. Piaget and B. Inhelder, *The psychology of the child*. Basic books, 2008.
- [92] H. O. Pollak, "How can we teach applications of mathematics?" *Educational studies in mathematics*, pp. 393–404, 1969.
- [93] P. Reimann, "Design-based research," in *Methodological choice and design*. Springer, 2011, pp. 37–50.
- [94] S. F. Rubin, "Evaluation and meta-analysis of selected research related to the laboratory component of beginning college level science instruction." 1997.
- [95] D. Russell, "Group collaboration in an online problem-based university course," *Problem-based learning and Creativity*, pp. 173–192, 2009.
- [96] A. H. Schoenfeld, "When good teaching leads to bad results: The disasters of 'well-taught' mathematics courses," *Educational psychologist*, vol. 23, no. 2, pp. 145–166, 1988.
- [97] —, "Learning to think mathematically: Problem solving, metacognition, and sense making in mathematics (reprint)," *Journal of Education*, vol. 196, no. 2, pp. 1–38, 2016.
- [98] J. W. Schofield, "Increasing the generalizability of qualitative research," *Social research: Philosophy, politics and practice*, pp. 200–225, 1993.
- [99] B. Sriraman and G. Kaiser, "Theory usage and theoretical trends in europe: A survey and preliminary analysis of cerme4 research reports," *Zentralblatt für Didaktik der Mathematik*, vol. 38, no. 1, pp. 22–51, 2006.
- [100] E. Stringer, "Action research in education pearson merrill prentice hall," *New Jersey*, 2004.
- [101] E. T. Stringer, *Action research in education*. Pearson Prentice Hall Upper Saddle River, NJ, 2008.
- [102] D. Thomas and J. S. Brown, *A new culture of learning: Cultivating the imagination for a world of constant change*. CreateSpace Lexington, KY, 2011, vol. 219.

- [103] A. Treffers, *Three dimensions: A model of goal and theory description in mathematics instruction* *The Wiskobas Project*. Springer Science & Business Media, 2012, vol. 3.
- [104] M. Van Den Heuvel-Panhuizen, "The didactical use of models in realistic mathematics education: An example from a longitudinal trajectory on percentage," *Educational studies in Mathematics*, vol. 54, no. 1, pp. 9–35, 2003.
- [105] P. Vos, "What is authentic in the teaching and learning of mathematical modelling?" in *Trends in teaching and learning of mathematical modelling*. Springer, 2011, pp. 713–722.
- [106] R. Walker, "Design-based research: Reflections on some epistemological issues and practices," in *Methodological choice and design*. Springer, 2011, pp. 51–56.
- [107] C. Winsløw, "Didactics of mathematics: an epistemological approach to mathematics education," *The Curriculum Journal*, vol. 18, no. 4, pp. 523–536, 2007.
- [108] —, "Anthropological theory of didactic phenomena: some examples and principles of its use in the study of mathematics education," *Un Panorama de TAD, CRM Docume*, pp. 117–138, 2011.
- [109] D. Woods, "Issues in implementation in an otherwise conventional programme," *The challenge of problem-based learning*, pp. 122–129, 1991.



**Part II**

**Papers**



# Paper A

## A Problem-Based Approach to Teaching a Course in Engineering Mechanics

IMAD ABOU-HAYT

Aalborg University, Denmark, imad@plan.aau.dk

BETTINA DAHL

Aalborg University, Denmark, bdahls@plan.aau.dk

CAMILLA ØSTERBERG RUMP

University of Copenhagen, Denmark, cr@ind.ku.dk

The paper has been published in  
*Educate for the future: PBL, Sustainability and Digitalisation*, pp. 495–505, 2020.



© 2020 Aalborg University Press, Denmark

*The layout has been revised.*



## Abstract

*Problem-Based Learning (PBL) can be defined as a learning environment where problems drive the learning. A teaching session begins with a problem to be solved, in such a way that students need to gain new knowledge before they can solve the problem. This paper discusses the application of PBL to teaching an introductory course in engineering mechanics at Aalborg University, Copenhagen, Denmark for 1<sup>st</sup> semester students enrolled in the program "Sustainable Design". We pose realistic problems which do not necessarily have a single correct solution. Project work in groups also presents itself as a supplement for conventional engineering education. The students themselves should interpret the problem posed, gather needed information, identify possible solutions, evaluate options and present conclusions. The paper also presents an initial assessment of the experiences gained from implementing PBL in the course.*

**Keywords:** *PBL; engineering mechanics; mathematics; interdisciplinary*

## 1 What is Problem-Based Learning?

In contrast to a traditional teacher-centered pedagogy, PBL is a learner-centered educational method, based on realistic problems encountered in the real world. These problems act as a stimulus for learning, integrating and organizing learned information in ways that will ensure its application to new, future problems.

The term *Problem-Based Learning* was coined in 1969 when McMaster University in Canada introduced PBL into its medical school in an effort to provide a multidisciplinary approach to medical education and to promote problem solving to its graduates [1]. PBL was soon adopted by many universities worldwide [2], including Aalborg University in Denmark. Educators and researchers are still showing increasing interest in PBL approaches, that claim to stimulate the students self-learning and to promote their communication skills.

In a PBL teaching situation, problems are introduced at the beginning of the lesson, *before* giving the students the relevant knowledge. By actively engaging with the problem, students can develop skills around identifying the information they need and also the possible sources of that information. The goal is to enable them to relate what they are learning in class to their own experiences as well as to important issues in their world [3].

Nowadays, internet technology brings with it a rapid explosion of easily accessible knowledge. Graduates are expected to be critical thinkers, problem solvers and systematic in their approach and possess lifelong learning skills. The interdisciplinary nature of real-life problems means that students need to be able to *integrate* knowledge and skills from a number of disciplines as well as have personal and communication skills to be effective group members. "The knowledge which is valued in problem-based learning is that which can be used in context, rather than that which justifies the structure of particular disciplines" [4, p. 16].

In PBL, an important task of the instructor is to initiate discussions in the class in order to enhance the students reasoning skills and encourage them to apply their previous experiences to a novel case, thus enabling them to identify areas of gaps in their knowledge and prepare them to new knowledge acquisition. Through PBL, students are gradually given more and more responsibility for their own learning and become increasingly independent of the teacher in their understanding [5]. One should also note that PBL is not merely preparing problems for the students to solve in the class, "but also about creating opportunities for the students to *construct* knowledge through effective interactions and collaborative inquiry" [6, p. 22].

It should be emphasized that PBL is not to be confused with *project-based learning*, even though both learning environments are similar in strategies. Project-based learning is a teaching method in which students acquire knowledge and skills by working for an extended period of time to investigate and respond to an authentic and complex question or problem [7] . At Aalborg University, project-based learning is strongly problem-oriented. The projects chosen are often practical industry problems, with new problems assigned to groups each year. Students work on the semester projects in groups, and each student group has assigned working space. Students choose a project from a list that the faculty has approved and all the semester projects have a common theme of study.

A comparative study of problem-based and project-based learning was made by Perrenet et al. [8]. The differences that they noted included:

- Project-based learning is closer to professional reality and therefore takes a longer period of time whereas PBL may only extend over a single session or a week.
- Project-based learning is more directed to the *application* of knowledge, whereas PBL is more directed to the *acquisition* of knowledge.
- Project-based learning is usually accompanied by subject courses that should presumably support the project, whereas PBL is not.

- Self-direction and autonomy are stronger in project-based learning than in PBL, since the learning process in project-based learning is less driven by the problem.

Despite these differences, both problem-based and project-based learning are student-centered and "emphasize the learning process instead of the teaching process" [9].

## 2 The Course Project

The curriculum of "Sustainable Design" includes both semester projects and courses [10], where the courses should presumably support the projects by providing the necessary engineering knowledge that could prove relevant in the semester projects. The course "Models, Mechanics and Materials" itself should include an introduction to statics and strength of materials as well as mathematical topics such as differential equations and linear algebra [11].

Given the different disciplines in the course, we wanted to use a student-centered pedagogy, rather than traditional teaching, that can help the students explore the *connections* between the topics of the course through an interdisciplinary course project. The choice fell on PBL, as it integrates *knowing and doing* when students solve authentic, holistic problems that they can relate to their own experiences as well as to produce results they can reflect on.

As PBL teachers, it is our responsibility to design teaching situations that provide guidance to tackle authentic situations and facilitate students' learning, in such a manner that the topics of the course are embedded within these teaching situations. The course project is therefore structured in a such a way that the fundamental topics in statics, strength of materials and mathematics are covered, as required by the curriculum of the course. The textbook by Hibbeler [12] is used throughout the course, together with hand-written notes, which are made accessible on Moodle <sup>1</sup>. The project in the course consists of three parts:

- Analysis and redesign of a swing (Fig. A.1a).
- Analysis and redesign of a chandelier hanging from a ceiling (Fig. A.1b).
- Modeling of a boy on a spring horse (Fig. A.1c).

---

<sup>1</sup>Moodle is a learning platform that provides educators, administrators and learners with an integrated system to create personalized learning environments.



(a) A girl on a swing.



(b) A chandelier.



(c) A boy on a spring horse

**Fig. A.1:** The three parts of the course project.

The project formulation is accessible for the students in the very first lecture, where we gave an overview of the topics of the course.

Each topic in the project was then introduced into the course lectures, such that as each major content of the course syllabus was covered, the students were asked to work in groups to complete the corresponding parts of the project. Each group had to submit progress reports periodically. This was useful in providing feedback to the students before they uploaded their final project reports to Moodle at the end of the semester.

A close look at the structure of the "Sustainable Design" program will reveal that *product design*<sup>2</sup> constitutes a major part of it. The designer is a problem solver who, given a problem or a need, applies such fields as physics, mathematics, hydraulics, electronics, metallurgy, strength of materials, dynamics, magnetism and acoustics in order to find a solution, namely, the new product [13].

One aspect of product design is related to the modeling of a real life design through simplified physical models that can be analyzed using the fundamental engineering concepts, such as those in this introductory course in engineering mechanics. This aspect of modeling is rarely illustrated in engineering textbooks developed for such introductory courses, despite its importance. Although these textbooks contain at the end of each chapter plenty of problems that reinforce the concepts covered in the chapter, they usually do not discuss the relationships with the other topics covered elsewhere in the textbook. This course project can thus be regarded as an attempt to *revitalize* the modeling aspect in design and to illustrate the links between all the fundamental concepts of the course that perhaps can lead to a better understanding of the big picture. We, PBL instructors, have an important educational mission: To enable the students to apply seemingly isolated, theoretical results to genuine, real problems they did not meet before. This is really where "understanding" a method or an equation comes to an end. Only in that case, the "mission is accomplished". In our course, we always began the lectures with unstructured discussions of issues related to the course project. The students were then given comprehensive introductions to the topic(s) of the day, and guided through a set of sample calculations on existing designs, as well be shown in the following section.

### 3 A Teaching Situation in Statics: An Example

To illustrate how we apply PBL in the course, a teaching situation in statics will be presented here. An mentioned in section 1, an important educational task of the instructor is the facilitation of class discussions in a PBL teaching situation. To illustrate how we apply PBL in the course, a teaching situation in statics will be presented here. An mentioned in section 1, an important educational task of the instructor is the facilitation of class discussions in a PBL teaching situation. Thus, in introducing the topic "Statics", the starting point was the "girl on the swing" project (Fig. A.1a). The class discussions

---

<sup>2</sup>The primary function of product design is to conceive a product that meets some specifications.

were triggered by the question "what are the conditions to be satisfied so the girl will be sitting still and does not move?". The "no force" condition emerged clearly from these discussions. The discussions then turned on the importance of giving "directions" to the forces exerted on the girl. This personalized knowledge about forces and equilibrium is transformed to a formal, precise knowledge by going through topics such as vectors, forces, free-body diagrams (FBD) and the conditions for equilibrium [12]:

$$\Sigma \vec{F} = 0 \quad , \quad \Sigma \vec{M}_O = 0$$

As an illustration of the principles of statics, a sample example was explained in the class (Fig. A.2). The example was chosen to be "statistically" similar to the first two questions in the course project.

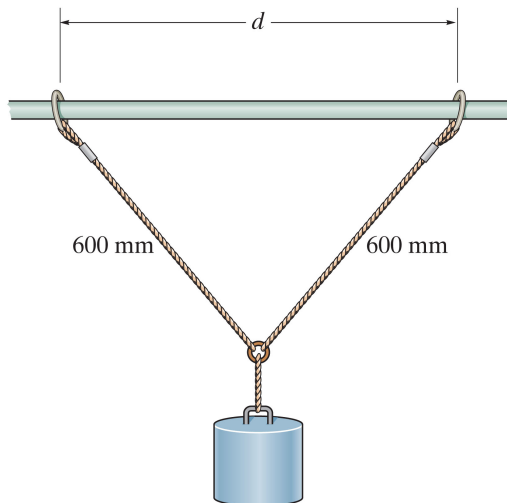


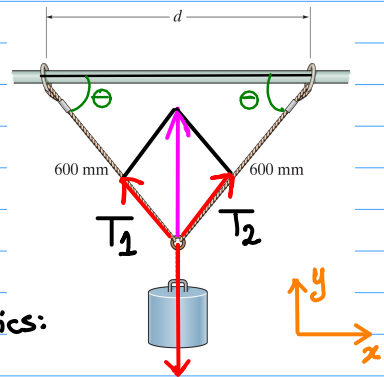
Fig. A.2: The example used to introduce statics.

The calculations and explanations were written with a stylus pen on a Wacom<sup>3</sup> tablet (Fig. A.3), the purpose of which was to free the students from writing or taking pictures of the board, as the document was uploaded on Moodle at the end of the lesson. In a PBL situation, it is important to give the students time to reflect on the methods used and to ask questions, rather than spend time taking notes from the board. This strategy is used thoroughly in the course lectures and in project-related explanations.

<sup>3</sup><https://www.wacom.com/en-dk>



This problem is "statically" equivalent to your "girl on a swing" project. We will determine the tensions in the ropes, given the weight of the cylinder.



Applying the laws of Statics:

$$\rightarrow \Sigma F_x = 0: -T_1 \cos(\theta) + T_2 \cos(\theta) = 0; \quad W$$

$$\text{So, } T_1 = T_2.$$

$$\uparrow \Sigma F_y = 0: T_1 \sin(\theta) + T_2 \sin(\theta) - W = 0;$$

$$\text{Since } T_1 = T_2, \text{ we get } \underline{T_1 = T_2 = \frac{W}{2 \sin(\theta)}}.$$

Given the distance  $d$ ,  $\sin(\theta)$  can be easily determined:

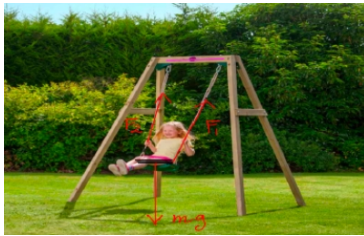
$$\sin(\theta) = \frac{\sqrt{600^2 - (d/2)^2}}{600}.$$

Fig. A.3: Solution of the sample example.

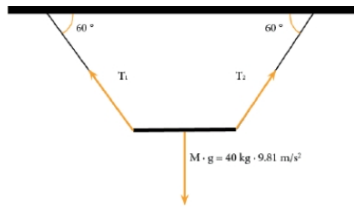
Similar teaching situations were prepared in the other topics of the course, namely, basic introductions to strength of materials and applied mathematics. In the following section, excerpts of the students solutions of the course project are shown.

## 4 Examples of Students Solutions

The raison d'être of the course project is to integrate different domains of knowledge and communication skills so that the students become able to tackle realistic problems. It is a **work in progress** in the course, since it consists of gradual stages through which the students should go through during the project. Each project group made observations and measurements in the initial stages of the project. Both parts of the project were open-ended with regard to outcomes, and thus, giving the students the freedom to choose an outcome that interests them. For example, some work groups came up with different materials for the cords holding the girl on the swing; others changed the design of the chandelier in the second part of the project so that it had two bars instead of three. According to the project formulation, the students should justify their conclusions and argue for their chosen designs. Given that student reflection is an important aspect in a PBL teaching situation, the students are therefore required to evaluate fully the results they have reached.



(a) The forces acting on the girl.



(b) An FBD of the girl.

Fig. A.4: An excerpt of a student solution in statics.

The lectures on matrices and linear equations were integrated in a major part of the course, namely, strength of materials. The parts b)-f) in the second part of the course project are thus designed to make a connection between linear algebra and the rest of the course, e.g., the link between the mathematical statement "two equations in three unknowns" and the fact that "the middle cord is redundant". The culmination of these parts was to make students reach the conclusion that a *consistent* system of three linear equations in three unknowns corresponds to the fact that the three forces in the chords could be determined, and thus to enable them to "see" linear algebra in action.

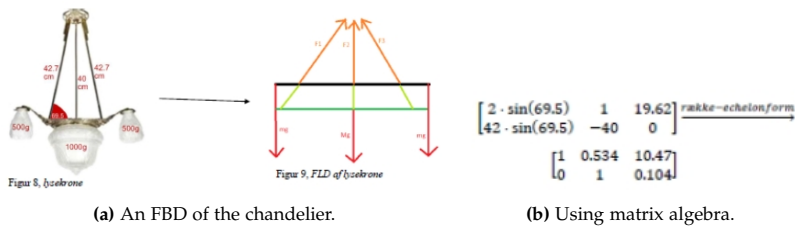


Fig. A.5: An excerpt of student solution in applying linear algebra.

The topic differential equations is also taught in the context of strength of materials, specifically in lectures on the deflection of beams, to reveal its importance as well as to provide the students with some real-life applications, that are relevant to the program "Sustainable Design".

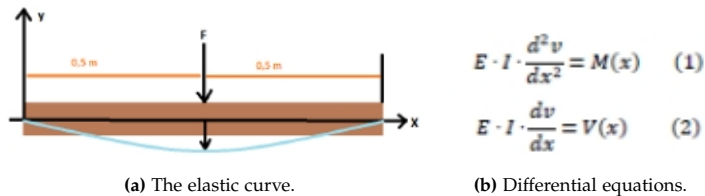


Fig. A.6: A part of a student solution of the deflection of the beam.

## 5 Course Evaluation

The course evaluation is used to provide the instructor and the study board with knowledge of the learning outcomes of the course and results of the feedback from students, in order to continuously improve it and to provide the students with suitable conditions for learning.

Implementation of PBL in the course was performed in the Autumn semester 2017 and again in the Autumn semester 2018. A preliminary assessment of this implementation of PBL in the course was made through a survey of the students at the end of the semester. The students evaluation of the course as well as their comments are made available for the instructor at the course homepage on Moodle<sup>4</sup>. A comparison of student evaluations in the years 2015-2018 is shown in Fig. A.7.

<sup>4</sup><https://www.moodle.aau.dk/course/view.php?id=26839>

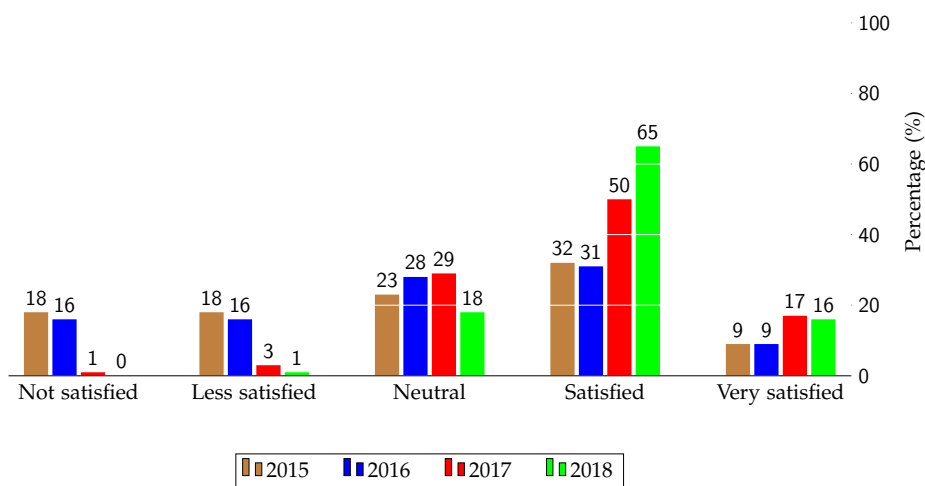


Fig. A.7: Comparison of student evaluations

It was observed that the students motivation in the course was improved considerably, compared with the previous surveys in the years 2015 and 2016. The course then was very teacher-driven and solely consisted of a series of lectures on the course topics, with no project involved.

Regarding the relevance of the course, most students agreed that the course project provided a practical illustration of real-life applications of the various fundamental topics covered in the course. The students felt, however, that they needed more guidance in completing the project. This can be quite challenging to achieve for the instructor, since a balance between the amount of guidance given to the students and the freedom that should be allowed for creativity in an open-ended problem is not easy to find.

The introduction of the PBL also changed the interaction and the relation between the instructor and the students quite significantly: The instructor assumed the rules of a project supervisor and a "visiting" group member, in addition to the usual rule as a lecturer. By participating in the group discussions, the instructor gained much insight into how the students tackled the problem, where genuine ideas are shaped and where students fell victims of flaws in their arguments. In fact, this was the most interesting part of the job as a lecturer!

The learning environment after the revision was much more focused on the needs of the students, rather than on the strict adherence to the course schedule. This required some flexibility on the instructor's part in responding

spontaneously to the project-related questions posed during the unstructured discussions and in adjusting the pace of the lecture to the progress made in the course project. In future offerings of the course, some adjustments to the schedule will have to be made. It is expected that the planning on which specific subjects to cover in the lectures and which ones to move to independent learning through the course project will require some adjustments.

Regarding group formation, letting the students determine the composition of the project groups entirely on their own based on friendships and working relationships from the semester project turned out to be, more or less, an adequate choice. Based on this procedure, many groups were formed through mutual agreement of all the members while some other groups essentially consisted of those students who, for some reason or another, were unable to form alliances. While it is rather clear that equal teams with culturally diversity and similarly distributed talent would be desirable, it is much less obvious how such a balanced distribution could be achieved. A group selection by the instructor would not necessarily result in equally strong teams since other qualifications such as previous leadership skills are as important for the group success as are analytic abilities and factual knowledge. Incompatibility due to work schedules and personality conflicts might also turn out as further impediments to the feasibility of the selection by the instructor. Therefore, during the next offering of the course, a random procedure, possibly with some minor adjustments by the instructor, will be adopted. It remains to be seen if such procedure will turn out to be fruitful.

Another challenge associated with team-based educational activities is the evaluation of both the individual contributions and achieved skill levels of the group members. Sometimes, student groups tend to cover for under-performing members. In that regard, anonymous questionnaires judging the contributions of all team members, had to be filled out by every student. In cases of obvious extreme discrepancies in the level of contributions, different final grades in the course was assigned for individual students in the group.

An analysis of student performance in the oral exams, which were designed to be of similar level of difficulty before and after the implementation of PBL, showed a measurable improvement of the students grades, especially in the "what if" questions posed during the exam.

## 6 Discussion and Conclusion

This article shows one way to implement PBL in an engineering mechanics course, where mathematics, engineering science and communication skills are taught in an integrated fashion, using a course project that deals with the solution of real-world problems and serves as a learning context. However, no claim is made that PBL would generally work in every engineering or science discipline. In fact, the suitability of PBL for engineering is still subject to debate among educational researchers. For example, Perrenet et al. [8, p. 349] reported that "findings from research on misconceptions suggest that PBL may not always lead to constructing the *right* knowledge", given that PBL is a constructivist theory of learning.

Moreover, as Mills and al. [2] pointed out, one of the obstacles to full implementation of PBL in engineering "would require interest, cooperation and integration of faculty from at least the engineering, mathematics, science and business/management divisions of an institution." Another important issue in a PBL implementation across a whole engineering program is related to the *hierarchical* knowledge structure of mathematics and engineering compared with medicine, where PBL has been widely adopted [14]. This is perhaps the most fundamental hindrance for implementation of PBL through an entire engineering program, as opposed to within individual courses in the program.

Our findings are thus more humble: PBL can be successful in *design-oriented* engineering programs, where product design plays a dominant role, since "Designing is a many-sided and wide-range activity" [15, p. 27], that is *interdisciplinary* in nature. This is exactly what we tried to achieve in the course project: To help the students in overcoming what appears to them as being disconnected subjects. It seems therefore that PBL may be a partial answer for resolving a critical issue of engineering education, namely the application context of the courses given in early stages of an engineering program.

It is generally acknowledged that design is one of the fundamental processes and activities in engineering. The strategy for teaching design, as has been practiced in engineering programs for many years [16], shares many similarities with PBL. These similarities have been noted by Williams et al. [17]:

- Both methods start with open-ended problems or realistic situations.
- Students progress in the project is dependent on their own learning.
- Students need to develop motivation and organization skills.
- Both PBL and teaching design have a number of gradual stages through

which to pass in order to acquire new knowledge.

- Observational skills are equally important for both PBL and teaching design, especially in the initial stages of the problem or project.
- Student reflection is an important aspect of both methods.
- Both methods rely on group work.

Hence it would appear that the implementation of PBL is a *logical extension* of the program "Sustainable Design", as both design and PBL are analogous in their approaches.

"Design projects play a vital role in providing students with a crucial attribute desired by industry for a newly graduated engineer: The ability to identify and define a problem, develop and evaluate alternative solutions and develop one or more designs to solve the problem. It is generally agreed that this attribute can only be developed by exposing students to the experience of open-ended problem solving which includes linking engineering science knowledge to complex, real-life design problems." [18]

Instructional, fact-based learning may continue to be important for becoming an expert at anything. In fact, using fact-based videos from websites like YouTube and Kahn Academy would make it easy for instructors to flip their classrooms by allowing students to digest instructional content at their own time and pace. This can be a genuine opportunity for instructors since it frees up class time to offer a PBL approach and personalized coaching to students as they work on projects in the class.

We believe that PBL strengthens the argument that topics like engineering mechanics and mathematics in design-oriented engineering programs, should be taught in a design context, through well-structured teaching situations that allow students to work with real-life problems, that they consider beneficial to the society. In fact, solving problems of the society and the environment may be the reason why the students chose the program "Sustainable Design" in the first place.

## References

- [1] H. S. Barrows, R. M. Tamblyn *et al.*, *Problem-based learning: An approach to medical education*. Springer Publishing Company, 1980.
- [2] J. E. Mills, D. F. Treagust *et al.*, "Engineering education—is problem-based or project-based learning the answer," *Australasian journal of engineering*

- education*, vol. 3, no. 2, pp. 2–16, 2003.
- [3] I. Askehave, H. L. Prehn, J. Pedersen, and M. T. Pedersen, “Pbl: Problem-based learning,” *Aalborg University*, 2015.
- [4] D. Boud and G. Feletti, *The challenge of problem-based learning*. Routledge, 2013.
- [5] H. S. Barrows, “A taxonomy of problem-based learning methods,” *Medical education*, vol. 20, no. 6, pp. 481–486, 1986.
- [6] O. S. Tan, *Problem-based learning innovation: Using problems to power learning in the 21st century*. Thomson Learning Asia, 2003.
- [7] S. Barge, “Principles of problem and project based learning-the aalborg pbl model. aalborg university,” 2010.
- [8] J. Perrenet, P. Bouhuijs, and J. Smits, “The suitability of problem-based learning for engineering education: theory and practice,” *Teaching in higher education*, vol. 5, no. 3, pp. 345–358, 2000.
- [9] A. Kolmos, “Reflections on project work and problem-based learning,” *European journal of engineering education*, vol. 21, no. 2, pp. 141–148, 1996.
- [10] Aalborg University, “Structure of the Sustainable Design program,” URL: <https://www.aau.dk/uddannelser/bachelor/baeredygtigt-design/fagligt-indhold/>.
- [11] —, “Curriculum of Sustainable Design,” URL: [https://www.sadp.aau.dk/digitalAssets/266/266090\\_bd-studieordning-2017.final-mts.pdf](https://www.sadp.aau.dk/digitalAssets/266/266090_bd-studieordning-2017.final-mts.pdf), 2017.
- [12] R. C. Hibbeler, *Statics and Mechanics of Materials in SI Units*. Pearson Higher Ed, 2018.
- [13] S. Tayal, “Engineering design process,” *International Journal of Computer Science and Communication Engineering*, vol. 18, no. 2, pp. 1–5, 2013.
- [14] G. Feletti, “Inquiry based and problem based learning: How similar are these approaches to nursing and medical education?” *Higher Education Research and Development*, vol. 12, no. 2, pp. 143–156, 1993.
- [15] G. Pahl and W. Beitz, *Engineering design: a systematic approach*. Springer Science & Business Media, 2013.
- [16] C. L. Dym, A. M. Agogino, O. Eris, D. D. Frey, and L. J. Leifer, “Engineering design thinking, teaching, and learning,” *Journal of engineering education*, vol. 94, no. 1, pp. 103–120, 2005.



- [17] A. Williams, P. Williams, M. Ostwald, and A. Kingsland, "Problem based learning: An approach to teaching technology," *Research and development in problem based learning*, vol. 2, pp. 355–367, 1994.
- [18] H. Schjær-Jacobsen, I. Abou-Hayt, D. Ashworth, M. P. Jensen, and M. P. Schreiber, "Industrial design as an innovative element in engineering education," in *Conference on Engineering Education*, 2012, p. 79.



# Paper B

## Teaching the Limits of Functions Using the Theory of Didactical Situations and Problem-Based Learning

IMAD ABOU-HAYT

Aalborg University, Denmark, imad@plan.aau.dk

BETTINA DAHL

Aalborg University, Denmark, bdahls@plan.aau.dk

CAMILLA ØSTERBERG RUMP

University of Copenhagen, Denmark, cr@ind.ku.dk

The paper has been published in the  
*Proceedings of the 47th SEFI Annual Conference 2019*, pp. 58–69, 2019.

© 2019 SEFI

*The layout has been revised.*



## Abstract

*The concept of limit plays a central role in the foundation of modern mathematical analysis. However, the concept itself plays a minor role in both upper secondary and undergraduate engineering education, leaving the students with many misconceptions about the concept, resulting in poor performance in calculus and calculus-based engineering courses. Most emphasis in teaching has been on how to calculate the limit instead of on understanding its definition. In this paper, we will use the frameworks of Brousseau's theory of didactic situations (TDS) and Problem-Based Learning (PBL) to suggest a method to teach engineering students the concept of limit and explain its formal definition. The purpose is to enable the students to generate a precise definition of limit of a function that captures the intended meaning of the conventional  $\epsilon$ - $\delta$  definition. Moreover, we will argue that TDS bears many similarities with PBL, as both frameworks require that the students act and engage in non-routine and realistic problems.*

## 1 Introduction

Although mathematicians have long accepted the concept of limit as the foundation of modern calculus, the concept of limit itself has been marginalized in upper secondary schools and undergraduate engineering programs. Engineering students' understandings of calculus will greatly influence their ability to study more advanced analysis courses and engineering courses, such as dynamics, since these courses all require calculus as a prerequisite. One obstacle that can contribute to the difficulties of teaching and learning limits is the symbolic representation of the limit itself,  $\lim_{x \rightarrow x_0} f(x)$ . It can give rise to apparently contradictory processes: One that potentially never ends, and another of getting close to. Nevertheless, as we will try to show in this paper, teaching the concept of limit successfully may not be an unattainable task if we use proper strategies and tools. The focus of this paper will be on how the PBL and TDS frameworks helped us in structuring our approach of teaching the concept of limit at both upper secondary and college level. Moreover, we demonstrate how PBL, in a mathematics teaching context, is compatible with TDS.

## 2 Why Limits are Important?

Teaching and learning the concept of limit has long been a very important subject to mathematics educators. In fact, the concept itself has a long and interesting history [1]. Many mathematical and engineering concepts depend upon the concept of limit and without a proper definition of it, mathematical analysis as we know it today would simply not exist, since basic notions in mathematics and engineering are limits in some sense, e.g.,

- Instantaneous velocity and acceleration are the limits of average velocities and average accelerations, respectively [2].
- The area of a circle is the limit of areas of inscribed polygon as the number of sides increases infinitely.
- The slope of a tangent line to a curve is the limit of the slope of secant lines.

## 3 On Problem-Based Learning (PBL)

In PBL, problems drive the learning. A teaching session begins with a problem to be solved, in such a way that students need to gain new knowledge before they can solve the problem. In contrast to a traditional teacher-centered pedagogy, PBL is a learner-centered educational method based on realistic problems encountered in the real world. These problems act as a stimulus for learning, integrating and organizing learned information in ways that will ensure its application to new, future problems [3]. Thus, PBL is not merely preparing problems for the students to solve in the class, but also about creating opportunities for the students to construct knowledge through effective interactions and collaborative inquiry. In PBL, an important task of the instructor is to initiate class discussions to enhance the students reasoning skills and encourage them to apply their previous experiences to a novel case, thus enabling them to identify areas of gaps in their knowledge and prepare them to new knowledge acquisition. Through PBL, students are gradually given more and more responsibility for their own learning and become increasingly independent of the teacher in their understanding. The methodology of PBL will be illustrated when we design teaching situations that gradually guide the students to the formal definition of limits.



## 4 On the Theory of Didactic Situations (TDS)

TDS is based on the idea that students construct new knowledge when they solve non-routine problems while adapting to what is called a didactical milieu [4]. Non-routine problems typically do not have an immediately apparent strategy for solving them. In TDS, the teachers aim is to engage the students by designing didactical situations in such a way that the targeted mathematical knowledge would be the best means available for understanding the rules of the game and elaborating the winning strategy [5]. The withdrawal of the teacher and the subsequent transfer of the responsibility of the learning situation to the students is the essence of Brousseau's notion of devolution, where the students become the owner of a given problem, and thus entering the didactic level, to produce the knowledge needed to solve it. [6] mentions four phases of didactic situations: Action, formulation, validation and institutionalization. These phases will be exemplified below when we create didactical situations that eventually lead the students to capture the idea of limit.

## 5 Research Questions

The main research questions of this article are

- How can we design didactical situations that lead to the rigorous  $\varepsilon$ - $\delta$  definition of limits in an introductory calculus course?
- Can the PBL and TDS frameworks be applied to teaching abstract notions in engineering mathematics, such as limits?

We will try to show that even seemingly theoretical notions in engineering mathematics are amenable to the PBL and TDS frameworks. The *raison d'être* of this paper came from two similar teaching situations that the first author taught to engineering students at a higher education level in 2018. These students had no experience with any mathematically rigorous processes using the definition or proofs related to limits. The didactical situations described below require that the students participate in well-designed activities that use some real-life problems, which presumably would guide the students to the correct conception of limits.

## 6 A Problem-Based Approach

### 6.1 Sources of Difficulties in the Teaching of the Concept of Limit

The differences between everyday language and the language of mathematics may contribute to the students' misconceptions, and hence also bring learning obstacles. For example, one may say that "my limit of running continuously is four kilometers". This everyday understanding of limit may suggest that a limit is some value one cannot exceed. The difficulties the students may encounter in understanding the concept of limit are discussed in [7], where three forms of obstacles to students' understanding of limits are mentioned:

- Epistemological obstacles related to the historical development and formalization of the limit concept.
- Cognitive obstacles related to the abstraction process involved in the formalization of the concept of limit.
- Didactical obstacles related to the ways the concept of limit is presented to students.

One consequence of these obstacles is that a formal definition of limits is not included in the Mathematics A curriculum in Denmark (the highest level possible), apparently due to its conceptual difficulty. Thus, upper secondary mathematics textbooks, such as the one by [8], give the following informal definition of limit:

**Definition.** If the values of the function  $f(x)$  approach the value  $L$  as  $x$  approaches  $x_0$ , we say that  $f$  has the limit  $L$  as  $x$  approaches  $x_0$  and we write

$$\lim_{x \rightarrow x_0} f(x) = L$$

The real motive behind introducing the limits of functions in upper secondary school mathematics is its use in defining the derivative of a function at a point:

**Definition.** The derivative of a function  $f$  at a point  $x_0$ , denoted  $f'(x_0)$ , is given by

$$f'(x_0) = \lim_{h \rightarrow 0} \frac{f(x_0 + h) - f(x_0)}{h}$$

provided this limit exists.

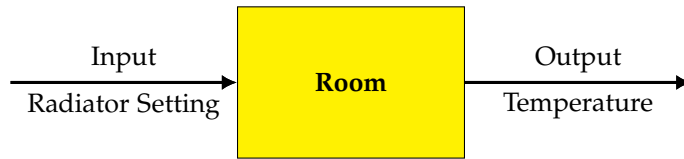
The definition of the derivative is a so-called indeterminate form of type

$\left[ \begin{smallmatrix} 0 \\ 0 \end{smallmatrix} \right]$  [9]. These forms can usually be evaluated by canceling common factors, which is the usual method used in upper secondary school mathematics. Thus, it seems that the limit concept is reduced to an algebra of limits, suppressing the topology of limits, which is crucial in the formal definition: This didactical obstacle may lead to the misconception that the algebra of limits and topology of limits may be completely disconnected. The informal definition of limits has therefore its shortcomings. Firstly, the definition does not precisely convey the mathematical meaning of the concept of limit. Secondly, the expression "approaches to" may result in the confusion whether limits are dynamic processes, where motion is involved, or static objects.

## 6.2 Teaching Situations Leading to the Concept of Limit

In response to the above-mentioned difficulties, we will show how we tackled teaching the concept of limit, using a terminology that is close to the one used in the formal definition, without sacrificing the topological aspect in the definition. Moreover, the concepts we use should be familiar to the students from their previous experiences. Specifically, we address the question: *Given a process or system, how can we control the error tolerance in the input, given that the output (or product) should have a given error tolerance?* So, in introducing the topic "Introduction to Limits of Functions" to the students, we started the lesson by giving the students five tasks. These tasks represent several teaching situations that may be needed to reach the institutionalized knowledge of limits of functions, i.e. the tasks can be regarded as a gradual transition from the students' personal knowledge to institutionalized knowledge.

**Task 1: Discussion.** How do you control the temperature of this classroom? Usually, we require that the room temperature to be the *ideal* 20°C, but can we be sure that it is precisely ? If a temperature of exactly is practically unattainable, how can we keep the temperature of the room close to it? The discussion is open for all students. Many students gave the answer We have to continuously adjust the settings of the radiator to guarantee that the temperature is always near . Other students argued that opening and closing the windows and the door also affect the temperature. All agreed that the temperature in the classroom is dependent on many factors. To make things simple, we intervened in the discussion and drew the following figure on the white board and asked the students to elaborate on it:



**Fig. B.1:** Controlling the room temperature by adjusting the settings of the radiator

The purpose of this task is to guide students to reach the (simple) conclusion: To *control* the room temperature, one should adjust the settings of the radiator. Using TDS terminology, this task corresponds to the *formulation* phase, where the milieu is an open discussion. The students here construct *personal knowledge* about radiators and heat while interacting with the problem of maintaining a constant room temperature. Using the figure, the students personal knowledge is being validated and becomes more formalized. Besides, this task encourages students to use relevant *experience-based knowledge* in order to arrive at a plausible conclusion, to use PBL terminology [10].

**Task 2:** *Circular plates.* The area of a circular plate is given by  $A = \frac{\pi d^2}{4}$ , where  $d$  is its diameter. A machinist is required to manufacture a circular metallic plate to be used in radio-controlled wall clocks. The area of the circular plate should be  $169\pi \text{ cm}^2$ . But since *nothing is perfect*, the machinist would be satisfied with an area machined within an error tolerance.

1. Within an error tolerance of  $\pm 1 \text{ cm}^2$  for the area, how close to 26 cm must the machinist control the diameter of the plate to achieve this?
2. Given a positive number  $\varepsilon$ . Within an error tolerance of  $\pm \varepsilon \text{ cm}^2$  for the area, find a formula for the resulting tolerance  $\delta$  of the diameter of the plate.

An excerpt of a student solution of Task 2 is shown in Fig. B.2.

a)

$$A = \frac{\pi d^2}{4}$$

$$169\pi - 1 < \frac{\pi d^2}{4} < 169\pi + 1$$

$$\frac{4(169\pi - 1)}{\pi} < d^2 < \frac{4(169\pi + 1)}{\pi}$$

$$674.727 < d^2 < 677.273$$

$$25.975 < d < 26.024$$

$$\underline{\underline{|d - 26| < 0.024}}$$

b)

$$169\pi - \varepsilon < \frac{\pi d^2}{4} < 169\pi + \varepsilon$$

$$\frac{4(169\pi - \varepsilon)}{\pi} < d^2 < \frac{4(169\pi + \varepsilon)}{\pi}$$

$$\sqrt{\frac{4(169\pi - \varepsilon)}{\pi}} < d < \sqrt{\frac{4(169\pi + \varepsilon)}{\pi}}$$

$$|d - 26| < \sqrt{\frac{4(169\pi + \varepsilon)}{\pi}} - 26$$

$$\delta = \sqrt{\frac{4(169\pi + \varepsilon)}{\pi}} - 26$$

Fig. B.2: An example of a student solution to Task 2.

The aim of Task 2 is twofold:

- To support the students development of personal knowledge regarding the concepts of closeness and distance, culminating in the result

$$|d - 26| < 0.024 \quad (\text{B.1})$$

- To help the students acquire new knowledge about tolerances, namely the fact that  $\delta$  depends on  $\varepsilon$ .

To use TDS terminology, the teacher hands over the milieu to the students by presenting the problem and explaining the rules for solving it in such a way that the students can engage in the intended activities [4]. This corresponds

to the *devolution* phase in TDS. This is also a PBL situation where teaching should offer the students the opportunity to engage in activities like those of a researcher. PBL assumes that students learn best when applying theory and research-based knowledge in their work with an authentic problem [3].

Engaging in the task, the students employ their previously developed experience with inequalities and absolute values in order to solve the problem. In TDS, this corresponds to the *action* phase, where the situation is *adidactical*.

**Task 3:** *Tolerances.* This is a *didactical* situation where we explicitly interact with the students, in order to improve their understanding of error tolerances and provide them with some background for the *independent acquisition* of knowledge about dependent and independent variables. The function of the machine is to take metal sheets as *input* to produce circular plates as the final products, i.e., the *output*.

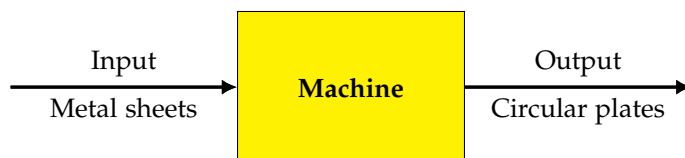


Fig. B.3: Controlling the the tolerance of  $d$  by adjusting the the tolerance of  $A$

The machinist must adjust the machine settings to satisfy the specifications of the products. The question now is: What error tolerance for the diameter  $d$  should be used so that the product (circular plates) requirements are met? Mathematically, given  $\varepsilon > 0$ , find  $\delta$  such that if  $|d - 26| < \delta$  then  $|A - 169\pi| < \varepsilon$  where  $A$  is the area of the circular plate.

**Task 4:** *A didactical game.* This task is a partial generalization of the third one. This task is really a didactical game consisting of a challenge and a response. The machine now is a function  $f$  that *transforms* a number  $x$  (input) to another number  $f(x)$  (output). Like the machinists work, we want the output  $f(x)$  to be equal to a number  $L$ . In practice, we may be satisfied with an output  $f(x)$  *somewhere* between  $L - \varepsilon$  and  $L + \varepsilon$ , where  $\varepsilon$  is the error tolerance of  $f(x)$ . The question now is how accurate our control setting for  $x$  (the input) must be to guarantee this degree of accuracy in the function value  $f(x)$ . This error tolerance for  $x$  is usually denoted by  $\delta$ . The function given to the students is  $f(x) = 5x - 3$ , together with the two numbers  $L = 2$  and  $x_0 = 1$ . The challenge is to make  $|f(x) - L|$  less than a given number  $\varepsilon > 0$  by finding a number  $\delta > 0$  such that  $|x - x_0| < \delta$ . The number  $\varepsilon$  itself is given in the following table:

**Table B.1:** A didactical game

The challenge $\varepsilon$	The response $\delta$
$\frac{1}{10}$	
$\frac{1}{100}$	
$\frac{1}{1000}$	
$\frac{1}{10000}$	

In the language of TDS, this task is the starting point directing the students acquisition of the institutional knowledge of limits. Within the framework of PBL, it helps students acquire the skills required to tackle new problems involving limits. The students were required to work in groups of two to find the response  $\delta$  of the challenge  $\varepsilon$ , by completing the table. A two-student group consisted of a skeptic and a scholar: The skeptic presented  $\varepsilon$ -challenges to show that there is room for doubt. The scholar should answer every challenge with a  $\delta$ -interval around  $x_0$  that keeps the function values within  $\varepsilon$  of  $L$ . The *culmination* of this task consisted of giving the students a new challenge: Find a formula for  $\delta$  in terms of  $\varepsilon$ .

The series of the tasks mentioned above constitutes a TDS teaching process to arrive at the sought definition of a limit. This process also conforms to the essence of a PBL framework [11]. The institutionalization of all these tasks, where the students personal knowledge finally reaches the state of institutional knowledge, is attained by confronting the students with the formal, rigorous definition of a limit of functions, as given in most engineering mathematics books, e.g. [9]:

**Definition.** We say that  $f(x)$  approaches the limit  $L$  as  $x$  approaches  $x_0$  if for every number  $\varepsilon > 0$  there exists a corresponding number  $\delta > 0$ , such that for all  $x$ , if  $|x - x_0| < \delta$  then  $|f(x) - L| < \varepsilon$ . We write

$$\lim_{x \rightarrow x_0} f(x) = L \quad (\text{B.2})$$

As a part of institutional knowledge, two remarks to this definition were mentioned to the students:

- The definition does not ask for a best positive  $\delta$ , just one that will work.

- Note that there is no need to evaluate  $f(x_0)$ : In fact,  $f(x_0)$  may or may not equal to  $L$  or may not exist at all! The limit  $L$  of the function  $f(x)$  as  $x \rightarrow x_0$  depends only on nearby values!

**Task 5: Exercise.** This final task consists of some exercises, the purpose of which is to test if the students grasp the concept of limit. Use the formal definition of limit to prove the indicated limits. Due to page limits, we only discuss one of these:

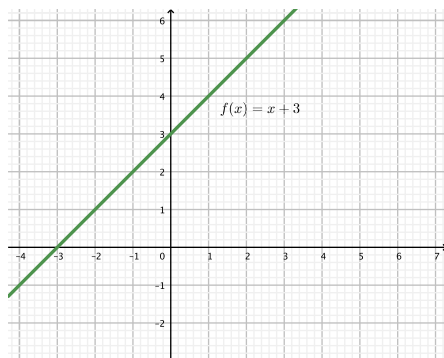
- Use a CAS tool to plot the graph of the function

$$f(x) = \frac{x^2 - 9}{x - 3} \quad (\text{B.3})$$

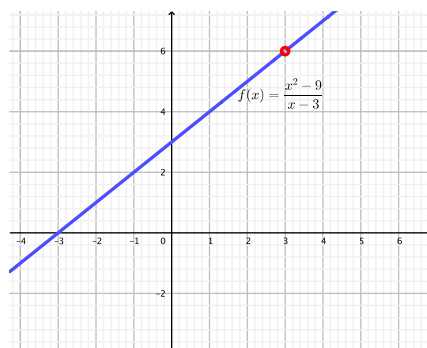
Show graphically that

$$\lim_{x \rightarrow 3} \frac{x^2 - 9}{x - 3} = 6 \quad (\text{B.4})$$

This task is a validation situation, i.e. students convey their ideas and the teacher plays a role of bridging their knowledge to achieve the intended knowledge [4]. Regarding this exercise, the students used GeoGebra and Maple. Both these CAS tools produced wrong plots of the function. The students, who are accustomed to use CAS to solve mathematical problems, including trivial operations on numbers, were surprised that the CAS tools failed to draw the right graph. They were not aware of the limitations of these CAS tools. Here is the misleading graph which all students got (Fig. B.4a):



(a) The wrong graph of the function



(b) The correct graph of the function

**Fig. B.4:** The two questions about vectors

The catch is that CAS tools automatically try to reduce an expression without



showing the condition under which the reduction is valid. In our exercise, the function is reduced to , without further notice: The result is a straight line, where  $x$  can be any number! It is too easy to declare that one should have a critical attitude regarding the outputs of CAS tools, as this requires deeper insight and knowledge in the internal workings of these tools, something most students do not possess. The impact of CAS tools on mathematics teaching and learning is still subject to intensive research [12] and it is beyond the scope of this paper to account for the possible contribution of CAS tools in improving the students understanding of mathematical topics. It is crucial to present the true graph of the function  $f(x) = \frac{x^2-9}{x-3}$  to the students (Fig. B.4b) and elaborate on the *analogy* with the previous tasks: A straight line with a hole at  $x = 3$  means of course that  $x \neq 3$ . However, this does not prevent us from investigating the values of the function for values of  $x$  that are close to 3, like what we did in the previous tasks. In **Task 1**, it was beyond our reach to require a room temperature of exactly 20°C, but we can get closer and closer to it. In **Tasks 2 and 3**, it was impossible to produce circular plates having a diameter of exactly 26 cm but we can get closer and closer to that. Similarly, in the exercise in **Task 5**, we cannot give  $x$  the value 3, and hence the function cannot have the value 6. However, *as the graph shows*, the function can get closer and closer to 6 whenever  $x$  is sufficiently close to 3.

## 7 Concluding Remarks and Discussion

According to the PBL framework, the problem is the starting point directing the students learning process. A problem can be both theoretical and practical. It must also be authentic and scientifically based [3]. The main requirement of the PBL framework is that the students seek new knowledge, through realistic problems. Thus, both PBL and TDS share the idea that a teacher provides students with the initial problem, so that the students act and formulate concepts related to the problem-solving activity.

At Aalborg University, both students and researchers are supposed to engage in problem-based, project-oriented approach in their academic work [13]. This paper itself can be regarded as a problem-based approach to applying TDS in introducing the theory of limits to engineering and upper secondary school students. In our own classes, many students were in fact able to prove that a given number is the limit of a given elementary function, using the formal definition. In fact, the problem that some students encounter was not in applying the definition, but rather in the algebra of inequalities involving absolute values.

The ultimate purpose of the tasks mentioned is to make students capture the *similarities* between the following situations:

- We cannot guarantee a room temperature of exactly  $20^{\circ}\text{C}$  but we can get close to it.
- We cannot produce circular plates having an area of exactly  $169\pi \text{ cm}^2$  but we can make their areas closer and closer to that.
- We cannot divide by zero, but it is legitimate to investigate the properties of a rational function, such as  $f(x) = \frac{x^2-9}{x-3}$ , for values close to the zeros of its denominator.

We therefore do not believe that the  $\varepsilon$ - $\delta$  definition of limits is too advanced for the mathematics curriculum at the upper secondary school and undergraduate engineering programs. Since, by using carefully designed teaching situations and pedagogical approaches, it can be possible to equip the students with a proper understanding of the concept of limit, and it will pay off in other mathematics and engineering science courses the students may encounter in their study.

## 8 Future research perspectives

The methodology of this concept paper has been used in an introductory calculus course for engineering students at Aalborg University in Copenhagen, Denmark. However, no pre-tests or post-tests were conducted in the course. The first author has only tested the students understanding of the concept of limit through *Task 5*. The informal assessment of the course seemed to be promising. However, more research in teaching the concept of limits at upper secondary schools is still needed to get a nuanced understanding of the students' conceptions and misconceptions of the idea of limit and what it might mean to come to understand the limit concept. Therefore, in a future offering of the course, the first author plans to design empirical tests that would reveal the impact the TDS and PBL approaches might have on the students understanding of limits. This would be an interesting subject of a new research paper.

## References

- [1] P. White and M. Mitchelmore, "Conceptual knowledge in introductory calculus," *Journal for Research in Mathematics Education*, pp. 79–95, 1996.
- [2] R. C. Hibbeler, *Engineering Mechanics Dynamics*. Pearson Education, 2017.
- [3] I. Askehave, H. L. Prehn, J. Pedersen, and M. T. Pedersen, "Pbl: Problem-based learning," *Aalborg University*, 2015.
- [4] G. Brousseau, *Theory of didactical situations in mathematics: Didactique des mathématiques, 1970–1990*. Springer Science & Business Media, 2006, vol. 19.
- [5] M. Artigue, M. Haspekian, and A. Corblin-Lenfant, "Introduction to the theory of didactical situations (tds)," in *Networking of theories as a research practice in mathematics education*. Springer, 2014, pp. 47–65.
- [6] A. Sierpińska, "Lecture notes on the theory of didactic situations in mathematics," 2003.
- [7] —, "Humanities students and epistemological obstacles related to limits," *Educational studies in Mathematics*, vol. 18, no. 4, pp. 371–397, 1987.
- [8] P. Bregendal, *MAT B HHX*. Systime, Aarhus, Denmark, 2011.
- [9] G. B. Thomas, *Thomas' Calculus*. Pearson Education, 2010.
- [10] A. Kolmos, "Problem-based and project-based learning," in *University science and mathematics education in transition*. Springer, 2009, pp. 261–280.
- [11] S. Barge, "Principles of problem and project based learning-the aalborg pbl model. aalborg university," 2010.
- [12] M. Artigue, "The future of teaching and learning mathematics with digital technologies," in *Mathematics Education and Technology-Rethinking the Terrain*. Springer, 2009, pp. 463–475.
- [13] A. Kolmos, F. K. Fink, and L. Krogh, *The Aalborg PBL model: progress, diversity and challenges*. Aalborg University Press Aalborg, 2004.



# Paper C

Exploring Students Conceptions of Vectors:  
A Phenomenographic Study

IMAD ABOU-HAYT

Aalborg University, Denmark, imad@plan.aau.dk

BETTINA DAHL

Aalborg University, Denmark, bdahls@plan.aau.dk

CAMILLA ØSTERBERG RUMP

University of Copenhagen, Denmark, cr@ind.ku.dk

The paper has been published in the  
*Proceedings of the 48th SEFI Annual Conference 2020*, pp. 33–44, 2020.

© 2020 SEFI

*The layout has been revised.*





"He cannot, England know, who  
knows England only."

---

Ference Marton

## Abstract

*The concept of vector plays a central role in engineering mechanics and strength of materials, where many quantities are vectorial in nature. Phenomenographic studies can be useful in revealing the different perspectives of the students understanding of vectors and variation theory is a promising approach to improve the teaching of vectors. In this study, we will use the frameworks of phenomenography and variation theory to explore students understanding and difficulties in using the concept of vector. The data consists of pre-, post- and delayed post-tests questions about vectors as well as student project reports in the course Models, Mechanics & Materials, given to first-year engineering students, studying Sustainable Design at Aalborg University, Copenhagen, Denmark. The results of the pre-test suggest that most emphasis in teaching vectors in upper secondary school mathematics has been on the algebraic representations of vectors and less on their graphical representations, the mastery of which is essential to succeed in engineering courses such as mechanics and strength of materials. The results of the post- and delayed post-tests as well as the students project reports showed some improvement in the students performances after using variation- and context-based teaching of vectors in the course. The article concludes with some proposals on how the results of this study can be used to enhance the teaching and learning of vectors at the upper secondary school and the university.*

**Keywords:** *vectors, phenomenography, variation theory, engineering mechanics, mathematics*

## 1 Introduction

Understanding many concepts in physics and engineering, such as force, moment and velocity, stands or falls on a firm grasp of the concept of vector [1] Several studies investigated students conceptions of vectors. For example, [2] investigated 2,031 physics students understanding of vector addition, magnitude and direction. They prepared a list of questions about vectors in all introductory general physics courses at Iowa State University as pre- and post-

tests. The outcomes showed that most of the students were unable to carry out two-dimensional vector addition after completing a physics course. [3] found that many students were not able to add or subtract vectors graphically after traditional instruction and could not answer qualitative questions about vector addition and subtraction. Their results are consistent with those of [2]: Students have difficulties performing basic vector operations. However, none of the previously mentioned studies investigating students understanding of vectors utilized a phenomenographic perspective to design a lesson in vectors and to explore specific aspects in students conceptions of vectors. This paper is an attempt to do so. Our empirical data consists of students achievements on vectors through a pre-, post- and a delayed post-test as well as students project reports in the course "Models, Mechanics & Materials", given to first-year engineering students in the years 2018-2019, studying "Sustainable Design" at Aalborg University, Copenhagen, Denmark.

Thus, the main purpose of the article is an investigation, using a phenomenographic perspective, whether the use of variation in teaching can contribute to improved learning of vectors. Variation theory is described below.

## 2 On Phenomenography and Variation Theory

How is it that two students who are sitting in the same class on the same day with access to the same materials can come to understand a vector (or any engineering concept for that matter) differently? There may be many answers to this question. "Variation theory is a theory of learning and experience that explains how a learner might come to see, understand, or experience a given phenomenon in a certain way" [4, p. 3391]. Variation theory stems from the phenomenographic tradition [5], which is an educational research method developed in the early 1980s by a research group at the Department of Education at the University of Gothenburg in Sweden [6]. It grew out of a series of empirical research studies that attempted to answer the questions "(1) What does it mean that some people are better learners than others? And (2) Why are some people better at learning than others?" [7, p. 146]. [6] asserts that there are a limited number of qualitatively unique ways in which different people experience or perceive the same phenomenon. Thus, the goal of phenomenographic research is to identify and describe the variation in experiences or perceptions that students have of a given phenomenon. The phenomenon under study can also be a concept or an event.

Variation theory, sometimes referred to as new phenomenography, reflects a shift within the phenomenographic research tradition that occurred in

the 1990s [4]. During that time, phenomenography was criticized as being a purely descriptive and theoretical framework. In other words, although phenomenography and its methods could be used to identify and describe the range of experiences a group of people had with a given phenomenon, it could not explain why that variation in experience existed. Variation theory can be seen as a more theoretical extension of phenomenography, in that it attempts to explain how students (and generally, people) can experience the same phenomenon differently and how that knowledge can be used to improve classroom teaching and learning [8]. One of the most important tenets of variation theory is that seeing differences precedes seeing sameness [9]. The quote mentioned at the top of this document illustrates this claim: You cannot possibly understand what English is simply by listening to different people speaking English if you have never heard another language. Similarly, you cannot possibly understand what a vector is by only inspecting different examples of vectors.

To gain a complete understanding of a phenomenon, four different patterns of variation have been identified. These signify the difference between the aspects that stay invariant in a learning situation and those that do not. These are [10]:

1. **Contrast:** A person needs a point of reference to compare something with something else.
2. **Generalization:** Variation in values of that aspect is necessary to discern the phenomenon.
3. **Separation:** In order to be able to separate certain aspects from other aspects, the phenomenon must vary while other aspects remain invariant.
4. **Fusion:** In cases where the phenomenon must be experienced in its entirety, it is necessary that a situation should be present where these aspects are all experienced simultaneously. Therefore, there is a fusion within the dimensions of variation of the specific critical aspects.

In variation theory, a teaching situation involves the intersection of two domains of knowledge and experience, the teacher sphere and the student sphere. The knowledge processed during a teaching situation can have three different outcomes [11]:

- The intended object of learning is what the teacher initially intended the students to learn.
- The enacted object of learning is what is made possible by the teacher for the students to learn in the lesson.

- The lived object of learning is what the students actually learn as a result of a learning situation. This knowledge can be analyzed both individually and group-wise.

The following representation of the three forms of knowledge is the authors own modification of the model proposed by [12, p. 210].

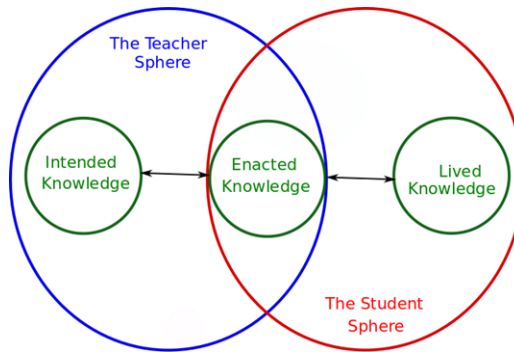


Fig. C.1: The three different perspectives of knowledge in variation theory

### 3 Study Methodology

The participants in the study are 42 first-year engineering students, enrolled in the study program "Sustainable Design" at Aalborg University, Copenhagen, Denmark. We chose these students because of convenience in sampling and also because the topics of the course can be found in many engineering programs. The students were given a pre-test in the first day of class of the course "Models, Mechanics & Materials", held in the Fall semester 2018. The first author was the lecturer in the course. The pre-test includes many questions about basic topics from upper secondary school mathematics, including the following two questions about vectors:

1. By referring to Figure C.2a below, it is given that  $|\vec{a}| = 4$  and  $|\vec{b}| = 3$ . Sketch the vector  $\vec{a} + \vec{b}$  and calculate its length (numerical value).
2. By referring to Figure C.2b below, it is given that  $|\vec{a}| = |\vec{b}| = 5$ . Sketch the vector  $\vec{a} - \vec{b}$  and calculate its length (numerical value).



Fig. C.2: The two questions about vectors

These questions are chosen because they represent some *critical features* of a vector (in contrast to a scalar, for example). The post-test and the delayed post-test consist of the same questions as the pre-test. The post-test was conducted at the end of the course in December 2018, where the students also had to submit a group report in the course project. The same class received the delayed post-test at the end of the Spring semester in June 2019.

The results of the tests are collected and analyzed, while the students project reports are made accessible on Aalborg University learning platform, *Moodle*. Assessing the students prior knowledge through a pre-test would make the students aware of the contents they are expected to learn and can potentially influence the learning experience of the students [13]. The purpose of the delayed post-test is to analyze the lived knowledge of the students as well as to enable the researcher to see whether the changes in knowledge have a long-term effect or only a short-term effect of the lesson. As educators and researchers, we are naturally interested in developing sustainable learning, since tests given directly after the lesson are not indicators of long-term change in the students experience.

## 4 Lesson Design

According to variation theory, the role of the teacher is to design learning experiences for students to make it possible for them to discern the critical features of the object of learning [14, p. 195]. However, variation in teaching does not guarantee that the student will in fact discern the object of learning at stake, as discerning depends on the students previous knowledge, current state of mind, interest in learning, etc. The curriculum of the course Mathematics A at the upper secondary education in Denmark (highest level) involves an introduction to two-dimensional vectors [15], mainly in coordinate form. Examining some textbooks that implement the curriculum, for example [16],

the authors found that the concept of vector is used merely as a synonymous of free vector, which is not enough for the university students to discern all the critical features of a vector, as applied in the course. Variation is therefore needed to discern those aspects of vectors not previously discerned by learners. Using variation and simultaneity between aspects, the students can learn to see vectors in new ways.

Presumably, the students have studied vectors as quantities having both a magnitude and direction in contrast to scalars, which only have a magnitude. Below we give excerpts of the actual lesson on vectors given by the first author. We started by reminding the students of what they have learned about vectors and scalars by giving examples, as in the following figure:

<b>Scalars &amp; Vectors</b>		
<u>Scalar</u>	vs	<u>Vector</u>
Distance		Displacement
speed		Velocity
mass		Force
Temperature		Acceleration

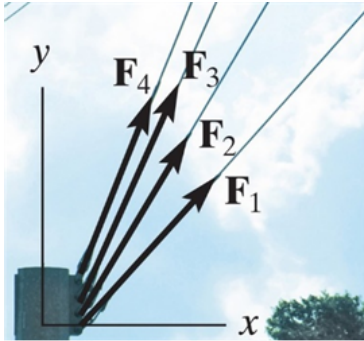
Fig. C.3: Scalars and vectors

We then asked the students to *compare* and *contrast* the vectors in the following two figures. In Fig. C.4a, the velocity of the rocket test sled is a free vector since the velocity is the same at all points in the sled whereas the two force vectors in Fig. C.4b are fixed (or bound) since changing their positions will alter their effects on the mattress. The velocity vector in Fig. C.4a corresponds to the *mathematical* definition of a vector (read: *free* vector). In Fig. C.4b, the two aspects magnitude and direction remained invariant while the point of application varied. This situation corresponds to the separation of aspects in variation theory.

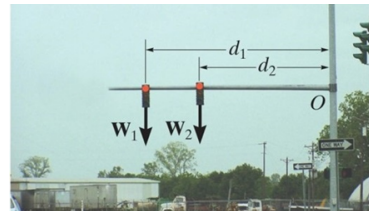


Fig. C.4: Free and fixed vectors

We then showed the students two different examples of a sliding vector. In Fig. C.5a, the four cable forces can slide along their respective lines of action, along the cables, similar to the weights of the two traffic lights in Fig. C.5b which can also slide along their respective lines of action, but perpendicular to the horizontal beam.



(a) Sliding vectors (I)



(b) Sliding vectors (II)

Fig. C.5: Examples of sliding vectors

A *fusion of all aspects* of a vector results when we generalize the mathematical definition of a vector, by giving our own definition:

**Definition.** A vector is a quantity that has a magnitude, direction, line of action and a point of action.

- If the line of action does not pass through a certain point in space, the vector is called a free vector. It is freely movable in space.
- If the line of action is fixed, the vector is called a sliding vector. It does not have a unique point of action.
- If the point of action is unique, the vector is called a fixed vector.

## 5 Results of the Study

The focus of this section is on whether teaching vectors using variation theory has contributed to improve the students understanding of some critical features of vectors. 42 students took the three tests, but only 40 answered to the delayed post-test.

Student conception	Pre-test scores	Post-test scores	Delayed post-test scores
1) Sketching $\vec{a} + \vec{b}$	70%	91%	74%
2) Finding $ \vec{a} + \vec{b} $	72%	80%	79%
3) Sketching $\vec{a} - \vec{b}$	27%	61%	53%
4) Finding $ \vec{a} - \vec{b} $	20%	39%	32%

Table C.1: Distribution of conceptions between Pre-, Post- and delayed post-test

Test	Mean	SD
Pre	1.87	1.08
Post	2.80	0.97
Delayed post	2.2	1.05

Table C.2: Mean and standard deviation (SD) for students achievement in the three tests

In order to find out if the differences between the scores of the pre-test and the delayed post-test were significantly different, or not, a paired  $t$ -test was conducted:

T Test, Difference of Means

	Sample 1	Sample 2
Mean	1.86	2.2
s	1.08	1.05
N	42	40
SE	0.2352	
df	79.964	
t	-1.4454	
P	0.0761	

Fig. C.6: Results of a statistical test to compare the two means of the pre-test and the delayed post-test

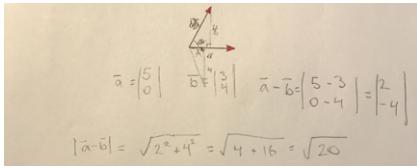


As seen in Tables C.1 and C.2, the students achieved significantly better test scores in the post- and delayed post-tests than in the pre-test although the delayed post-test scores were all a little below the post-test scores. For example, there was a considerable increase in the students' scores on sketching the difference vector from 27% in the pre-test to 53% in the delayed post-test. A close look at the results of the pre-test showed that many students who gave wrong answers in finding the length, have erroneously used Pythagoras' theorem to calculate the length, which they have previously learned in connection with finding the length of a vector, given in coordinate form. This would suggest that the geometrical aspects of vectors were given a minor role, whereas the algebra of vectors is much more dominant at the upper secondary school. In fact, the length and direction of a vector are critical geometrical features of a vector that cannot be discerned merely by using vector coordinates.

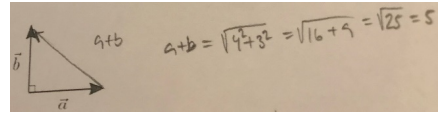
The paired  $t$ -test (Fig. C.6) found the  $p$ -value to be 0.0761, which means that we can reject the null-hypothesis that the mean difference between the two sets of answers is zero at a 10% significance level, but not at a 5% significance level. Thus the students did in fact score somewhat higher in the post-delayed test on average.

It seems, therefore, that using variation theory as a lesson design tool together with teaching vectors in the context of statics and strength of materials would improve students' learning in vectors. This study imparts some empirical evidence that support the use of variation theory as a pedagogical guide to design lessons in vectors in the classroom.

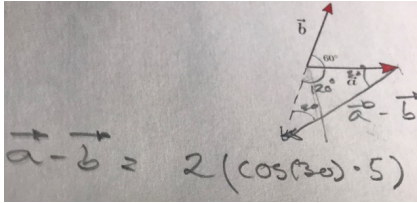
In the figures below, we show excerpts of some students answers.



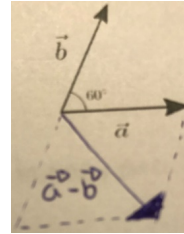
(a) A student's solution for finding  $|\vec{a} - \vec{b}|$  in the pre-test



(b) A student solution for finding  $|\vec{a} + \vec{b}|$  in the pre-test



(c) A student solution for finding  $|\vec{a} - \vec{b}|$  in the pre-test



(d) A student solution for finding  $|\vec{a} - \vec{b}|$  in the delayed post-test

Fig. C.7: excerpts of some students answers

## 6 Concluding Remarks and Discussion

Variation theory is a promising tool for investigating students conceptual understanding. However, the authors find that the theory ignores the effects of the students prior knowledge on the lived object of learning. In fact, some studies have shown that the students prior knowledge affects their learning when comparing multiple examples in teaching [17]. The students prior knowledge itself could be thought of as a pre-lived object of learning, while students understanding of the object of learning after the learning event takes place could be a post-lived object of learning. However, each individual encounters a unique set of experiences that shapes a unique cognitive framework and guides the perception and integration of new knowledge within the individual. Thus, prior knowledge is an important element in the construction of conceptual knowledge [18]. That is why we decided to integrate the students prior knowledge about vectors to construct a new understanding of vectors, which itself becomes part of the students prior knowledge for a future learning experience. As seen in Tables 1 and 2, the results of the delayed post-test seem to suggest that the students did not fully retain what was learned, but the fact that a lot was retained means that this knowledge would indeed become part of the pre-lived object of learning. Furthermore, when the students took

the delayed post-test, they were busy with the actual exams and motivating them to take this test for the benefit of research was not easy, which might also explain the drop.

In this regard, the authors suggest that the curriculum of vectors in Mathematics A at the upper secondary schools and in engineering mathematics courses should include all kinds of vectors that the students will encounter in science and engineering, given the fact that many students enrolled in Mathematics A will study science, mathematics, engineering or technology at the university.

Since instructional materials, including both physical and virtual resources, are designed to facilitate learning [19], they can have an unintended influence on the enacted object of knowledge. Therefore, the authors call for the inclusion of more examples on the geometrical aspects of vectors and their applications in physics and engineering in upper secondary mathematics textbooks.

## 7 Future Research Perspectives

Recent research studies reported that the integration of variation theory in classroom instruction improves students performance significantly [20], [21]. Considering the success of the integration of variation theory in teaching vectors, it is possible to combine variation theory, animations and Problem-Based Learning (PBL) in major topics of the course, such as equilibrium of rigid bodies, materials behavior and stress analysis, by allowing students to construct their own knowledge. Studying the different forms of the objects of learning during their three phases: the intended, the enacted (read: *constructed*) and the lived, and the influence they would have on the learning outcomes of the whole course, would be an interesting subject for a future article.

## References

- [1] J. M. Aguirre and G. Rankin, "College students' conceptions about vector kinematics," *Physics Education*, vol. 24, no. 5, p. 290, 1989.
- [2] N.-L. Nguyen and D. E. Meltzer, "Initial understanding of vector concepts among students in introductory physics courses," *American journal of physics*, vol. 71, no. 6, pp. 630–638, 2003.

- [3] S. Flores, S. E. Kanim, and C. H. Kautz, "Student use of vectors in introductory mechanics," *American Journal of Physics*, vol. 72, no. 4, pp. 460–468, 2004.
- [4] M. Orgill, "Variation theory," *Encyclopedia of the sciences of learning*, pp. 3391–3393, 2012.
- [5] U. Runesson, "Beyond discourse and interaction. variation: A critical aspect for teaching and learning mathematics," *Cambridge journal of education*, vol. 35, no. 1, pp. 69–87, 2005.
- [6] F. Marton, "Phenomenographydescribing conceptions of the world around us," *Instructional science*, vol. 10, no. 2, pp. 177–200, 1981.
- [7] M. F. Pang, "Two faces of variation: On continuity in the phenomenographic movement," *Scandinavian journal of educational research*, vol. 47, no. 2, pp. 145–156, 2003.
- [8] K. Tan, "Variation theory and the different ways of experiencing educational policy," *Educational Research for Policy and Practice*, vol. 8, no. 2, pp. 95–109, 2009.
- [9] F. Marton, "Sameness and difference in transfer," *The journal of the learning sciences*, vol. 15, no. 4, pp. 499–535, 2006.
- [10] F. Marton, A. B. Tsui, P. P. Chik, P. Y. Ko, and M. L. Lo, *Classroom discourse and the space of learning*. Routledge, 2004.
- [11] A. Kullberg, U. R. Kempe, and F. Marton, "What is made possible to learn when using the variation theory of learning in teaching mathematics?" *ZDM*, vol. 49, no. 4, pp. 559–569, 2017.
- [12] C.-J. Rundgren and L. A. Tibell, "Critical features of visualizations of transport through the cell membrane-an empirical study of upper secondary and tertiary students' meaning-making of a still image and an animation," *International Journal of Science and Mathematics Education*, vol. 8, no. 2, pp. 223–246, 2010.
- [13] J. H. McMillan and S. Schumacher, "Research in education: Evidence-based inquiry, myeducationlab series." *Pearson*, 2010.
- [14] M. Ling Lo, *Variation theory and the improvement of teaching and learning*. Göteborg: Acta Universitatis Gothoburgensis, 2012.
- [15] The Danish Ministry of Education, "Curriculum of mathematics in the upper secondary school," URL: <https://www.uvm.dk/gymnasiale-uddannelser/fag-og-laereplaner/laereplaner-2017/stx-laereplaner-2017>, 2017.

- [16] P. Bregendal, *MAT A HHX*. Systime, Aarhus, Denmark, 2011.
- [17] B. Rittle-Johnson, J. R. Star, and K. Durkin, "The importance of prior knowledge when comparing examples: Influences on conceptual and procedural knowledge of equation solving." *Journal of Educational Psychology*, vol. 101, no. 4, p. 836, 2009.
- [18] J. D. Novak, "Concept mapping: A useful tool for science education," *Journal of research in science teaching*, vol. 27, no. 10, pp. 937–949, 1990.
- [19] P. Grossman and C. Thompson, "Curriculum materials: Scaffolds for new teacher learning? a research report. document r-04-1." *Center for the study of teaching and policy*, 2004.
- [20] R. Huang and Y. Li, *Teaching and learning mathematics through variation: Confucian heritage meets western theories*. Springer, 2017.
- [21] T. J. Jing, R. A. Tarmizi, K. A. Bakar, and D. Aralas, "The adoption of variation theory in the classroom: Effect on students algebraic achievement and motivation to learn," *Electronic Journal of Research in Educational Psychology*, vol. 15, no. 2, pp. 307–325, 2017.



# Paper D

## Integrating the Methods of Mathematical Modeling and Engineering Design in Projects

IMAD ABOU-HAYT

Aalborg University, Denmark, imad@plan.aau.dk

BETTINA DAHL

Aalborg University, Denmark, bdahls@plan.aau.dk

CAMILLA ØSTERBERG RUMP

University of Copenhagen, Denmark, cr@ind.ku.dk

The paper has been published in the  
*Proceedings of the Eleventh Congress of the European Society for Research in  
Mathematics Education* No. 3, 2019.



© 2019 CERME11

*The layout has been revised.*



## Abstract

*In this paper, we show how an integration of the engineering design method and the mathematical modelling method can be applied in engineering. This is exemplified through two student projects in the first-year modules Dynamics and Vibrations and Models, Mechanics and Materials, which are compulsory in the Sustainable Design engineering programme at Aalborg University, Denmark. We first describe and discuss the definitions of the two methods and argue that they have many similarities and that the differences appear to vanish once they are combined in an introductory engineering project. We argue that when students experience how the two methods are applied in a project, they may develop a better holistic understanding of the problems they may encounter as future engineers. They are thus better equipped to solve future real-life problems by having applied mathematics and engineering sciences as integrated activities.*

**Keywords:** *Engineering design; mathematical modelling; problem-based learning*

## 1 Introduction

One of the major functions of design engineers is to solve problems for the society in which they live. Design engineers work on products and systems that involve adapting and using engineering and mathematical techniques and they usually work with a team of engineers and other designers to develop conceptual and detailed designs that ensure a product works and is suitable for its purpose. In this paper, we will describe and discuss an example of how the engineering design process, mathematical modeling, and problem-solving activity are integrated through introductory first-year projects in the Sustainable Design engineering program at Aalborg University (AAU) in Copenhagen, Denmark. Underlying the example is an assumption that by combining the engineering design process and the mathematical modeling process in an engineering context, students will be much more prepared to tackle the real-life problems that they might encounter in their future profession as engineers.

As we will show in this paper, the integration of the two methods conforms to the method of Problem-Based Learning (PBL) that AAU has adopted since it was founded in 1974. As argued by Kolmos, Holgaard, and Dahl in [1], there is not one single AAU PBL model, but nevertheless, the programmes at AAU are all organized around shared PBL principles described by [2] and [3]. These principles are problem orientation, project organization, integration

of theory and practice, participant direction, a team-based approach, and collaboration and feedback. The students therefore work in teams on open problems and the work includes all the steps from problem identification and problem analysis to problem solving. PBL is thus a student-centered learning method that uses real problems as a stimulus or starting point for the acquisition and integration of new knowledge. The teacher acts as an initiator and facilitator in the collaborative process of knowledge transfer and development. Parallel to the projects, the students also undertake modules which typically follow a more traditional style with lectures and exercises. The major characteristics of PBL projects include adaption to students prior knowledge and experience, integration of knowledge, and teaching in relevant contexts.

The purpose of this paper is to show how to integrate the teaching of mathematics and engineering mechanics within the framework of PBL in order to enhance the students understanding of both subjects as well as to introduce them to real-life situations, where the real problems they meet are mostly combinations of engineering, technology, and mathematics. When working on such problems in the real world, engineers, designers and applied mathematicians work together as a team to create new products. We aim to "transfer" these situations to the classrooms so that the students can develop an early acquaintance with the real thing. This requires carefully designed teaching scenarios that help make both mathematics and engineering interesting to learn.

The main research questions of this paper are therefore: Can we design didactical situations that integrate mathematics and engineering mechanics through design projects that resemble practical problems? Is it possible to teach mathematics in connection with engineering courses so that the students can capture the essence of both subjects through design projects? To answer these questions, we investigate mathematics teaching through design projects, using mathematical modeling as a didactic tool. The problem that we address here is the lack of interest in mathematics courses among engineering students [4]. This issue may eventually lead to poor understanding and performance on engineering science courses that depend on the mathematical concepts taught in traditional mathematics modules. The significance of the paper is therefore that it suggests a method that might solve this problem by offering teaching experiments that integrate some real-life problems with some central concepts in engineering mathematics. The aim of the student projects is to make mathematics more interesting for engineering students and to improve their understanding of engineering and mathematics courses.

## 2 The Processes of Mathematical Modeling and Engineering Design

### 2.1 Mathematical Modeling as a Design Process

Mathematical modeling is used in a variety of disciplines. A mathematical modeling competence is considered central in both engineering and mathematics education. When doing mathematical modeling, a part of reality is encoded into a set of mathematical rules and equations. There are in fact many models or descriptions of the mathematical modeling process. Due to page restrictions, we show only one example of such a model [5]. The one chosen was developed for use in education and is thus relevant. Every mathematical modeling process must begin with a problem or an observation, which is a process that fits well with a PBL project which also starts with open problems that require a solution. The problem can be either a well-defined physical question requiring a mathematical solution or a loosely described technical problem requiring a solution but with no obvious choice of mathematical model. However, since a mathematical model is an abstraction and mathematics itself is an abstract discipline, the starting point of the modeling process is to decide which aspects of the real world to observe and which to ignore.

The mathematical modeling process is as creative as the engineering design process, as engineers need to model devices and processes if they want to design these devices and processes. Just like the design of a certain product, a model of a specific physical situation may be good or bad, simplistic or sophisticated, aesthetic or ugly, useful or useless, but a model or design cannot be considered true or false. A mathematical model is therefore designed to correspond to a prototype, which may be a physical, biological, social, or psychological entity or yet another conceptual one. According to [6], the engineering design process is a sequence of steps that a designer takes to go from identifying a problem or need to developing a solution that solves the problem or satisfies the need. If we just replace the words design and designer with modelling and modeller, we arrive at a definition of mathematical modelling that is close to the one described above by Blomhøj and Jensen (2003). The engineering modeling process is therefore the set of steps that a modeller takes to go from first identifying a problem or need to ultimately creating and developing a solution that solves the problem or meets the need. Thus, the two processes have identical objectives and, in fact, can be broken down into a series of similar steps, as seen in Table D.1. The table constitutes the theoretical framework of this article. Both processes are different from the

scientific method although they also have some things in common. As argued by [7], the two processes begin with an open task, but while the engineering process begins with a problem or a need, the scientific method begins with a question. Furthermore, engineers look for suitable solutions while scientists look for suitable hypotheses to answer the question, that is, ultimately some generalized knowledge. Thus, engineers create new products using a more pragmatic modeling approach in which the models are convenient approximations to specific parts of reality.

<b>The mathematical modelling process</b>	<b>The engineering design process</b>
<b>1a)</b> Begins with a problem	<b>1b)</b> Begins with a problem
<b>2a)</b> Select relevant objects, relations, and data and idealize these	<b>2b)</b> Do background research to define suitable criteria and constraints for problem solution
<b>3a)</b> Translate the objects into a mathematical representation	<b>3b)</b> Specify requirements for solutions
<b>4a)</b> Use mathematical methods to arrive at results	<b>4b)</b> Evaluate the solutions against the criteria. Are there alternative solutions?
<b>5a)</b> Interpret the results in relation to the initial question	<b>5b)</b> Choose a suitable solution and build a prototype
<b>6a)</b> Evaluate the model	<b>6b)</b> Make recommendations; test and redesign as necessary
<b>7a)</b> Communicate the results	<b>7b)</b> Communicate the results

**Table D.1:** A comparison of the modelling and design processes

The table shows that the mathematical modelling process and the engineering design process are quite analogous. Below, we design two teaching situations that can provide some justification for Table D.1 as these situations integrate mathematics and engineering mechanics in realistic design projects.

## 2.2 Mathematics in an Engineering Context: An Example

The study of differential equations has always been a major part of the mathematics curriculum in engineering education. This is expected as many engineering problems involve equations that relate the changes in some key variables to each other. Therefore, differential equations are used to investigate a wide variety of problems in sciences and engineering.

Below we present a classical problem from engineering dynamics that illustrates the use of Table D.1 in differential equations, specifically second-order differential equations. The mechanical system is shown in Figure D.1.

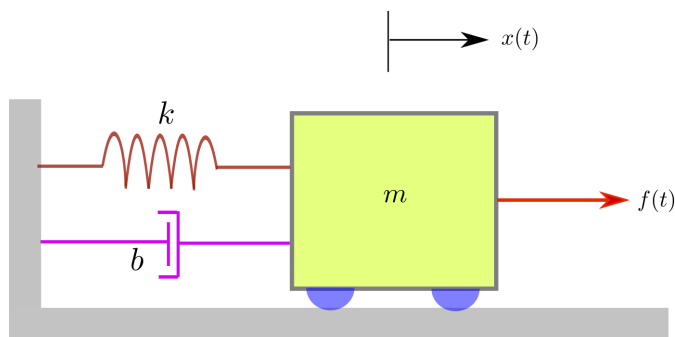


Fig. D.1: A mechanical system

Besides being a standard textbook problem, it is also seen in real-life problems such as modeling the suspension system of a car or the vibration of a wind turbine blade. Such real-life problems fit a PBL education model well as they can be quite open and can thus be approached by a problem-based strategy. At the same time, they also fit the framework shown in Table D.1, as items **1a** and **1b** in the table indicates that the starting point is a problem. The problems require analysis and simulation before a solution is reached. The analysis and simulation can be identified as items **25** for both processes in Table D.1:

- Create the idealization and formulate constraints (items **2a** and **2b**)
- Encode the system into mathematical language, specify the requirements (items **3a** and **3b**)
- Solve the resulting equation(s) and check the results (items **4a** and **4b**)  
Interpret the results and build a prototype (items **5a** and **5b**)

To apply Table D.1, we begin by assuming constant parameters for the spring and the damper (items **2a** and **2b**). Using Newtons second law, the mechanical

system can be described by the second-order linear differential equation with constant coefficients (items **3a** and **3b**):

$$m \cdot \ddot{x} + b \cdot \dot{x} + k \cdot x = f(t) \quad (\text{D.1})$$

Here  $x(t)$  is the position of the mass  $m$ ,  $b$  is the damping constant,  $k$  is the spring constant, and  $f(t)$  is the force applied on the mass. The students have already completed a mathematics module involving *linear* second-order differential equations. The purpose is to illustrate the different solutions of Equation D.1 by changing the values of the constants  $b$  and  $k$ . By plotting the response for some chosen values of  $b$  and  $k$  (items **4a** and **4b**), students can see the different behaviors of the system and gain a better understanding of the underlying mathematics of the mechanical system, thus accomplish items **5a** and **5b**. To choose appropriate values of  $b$  and  $k$  requires that tests and a redesign be carried out, thus accomplishing items **6a** and **6b**. It is therefore pedagogically sound to base the teaching of linear second-order differential equations on systems whose behavior students already intuitively understand. This illustrates that PBL, through working with open problems, can help the students achieve a better understanding of mathematics by using mathematical modeling as a didactic principle in teaching engineering mechanics and mathematics itself through the process illustrated in Table D.1. Finally, the students accomplish items **7a** and **7b** through communicating the results to their peers and teachers as part of the module.

The students ability to solve linear differential equations by using standard methods or formulas is therefore insufficient to understand fully the link between the mathematics learned and the other modules and projects. Students may eventually ask how we know that the parameters of the spring and the damper are constants. There are typically two different answers, we can give the students:

- Real springs and dampers have approximately linear behaviour.
- By assuming constant parameter values for the spring and damper, we can use the standard methods to solve linear differential equations, as we have a complete theory of linear differential equations, and not, e.g., a complete theory of *nonlinear* differential equations.

These answers can, however, be disputed by the fact almost all systems are nonlinear to some extent [8]. Besides, many of the student projects in which the first author was involved as a supervisor involve nonlinear phenomena. However, as the students were only introduced to linear second-order differential equations in their mathematics module and are still in their first year of study, we will at this point assume linear behavior of the systems



involved.

### 3 Mathematical Modeling in Action

#### 3.1 Example 1: Model of a Lego Van and a Caravan

In a project in the second-semester module "Dynamics and Vibrations" for the Sustainable Design engineering program, the students should construct a mathematical model of the popular van and caravan playset by the Danish company Lego. In the context of Table D.1, the problem of the project is to determine the response of the caravan if the van moves on a straight road with a constant acceleration  $a$ . This corresponds to items **1a** and **1b** in the Table. Ideally, the caravan should follow the kinematics of the van as closely as possible. The project can illustrate the use of PBL as a framework in teaching an engineering mechanics module, where mathematics and mechanics are integrated in a realistic project through the process of mathematical modeling. The PBL project thus conforms to Table D.1, as it starts with a problem that requires mathematical tools to arrive at acceptable results. A simplified model of the system is shown in Figure D.2. Many students immediately see the similarity of this concrete system with the ideal one in Figure D.1: The constant acceleration of the van gives rise to a constant force on the caravan. Some also realize that the *flexible linkage* between the van and the caravan can be *modeled* as a spring and a damper.

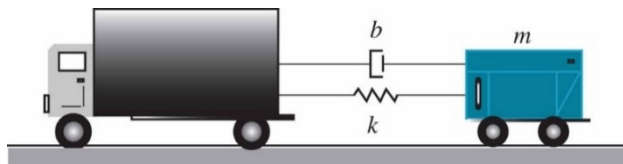


Fig. D.2: A model of the Lego project

If we let  $x_1(t)$  and  $x_2(t)$  denote the positions of the van and the caravan respectively, Newton's second law [9] leads to the differential equation of the model:

$$m \cdot \ddot{x}_2 + b \cdot (\dot{x}_2 - \dot{x}_1) + k \cdot (x_2 - x_1) = 0 \quad (\text{D.2})$$

As the van's acceleration is constant, we have  $\dot{x}_1 = a \cdot t$  and  $x_1 = \frac{1}{2} \cdot a \cdot t^2$ , where the initial conditions are assumed to be zero. Equation D.2 can finally

be written as

$$m \cdot \ddot{x}_2 + b \cdot \dot{x}_2 + k \cdot x_2 = a \cdot b \cdot t + \frac{1}{2} \cdot a \cdot k \cdot t^2 \quad (\text{D.3})$$

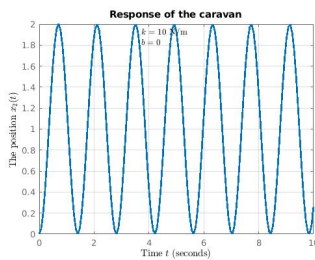
Comparing Equations D.3 and D.1, the students see that the term  $a \cdot b \cdot t + \frac{1}{2} \cdot a \cdot k \cdot t^2$  corresponds to the force  $f(t)$ . We are led to a second-order non-homogeneous differential equation where the unknown function is  $x_2(t)$ . This is exactly the type of differential equation, which the students have met in their mathematics module; they now meet it in an *engineering context*. Thus, Table D.1's items **2a**, **2b**, **3a**, and **3b** are now satisfied. The students now see an old friend in action! Thus, we anticipate that this will offer some justifications to the students in answer to their eternal question "Why do we need to study differential equations?" in the context of their experience.

### 3.2 Student Simulation of the Model

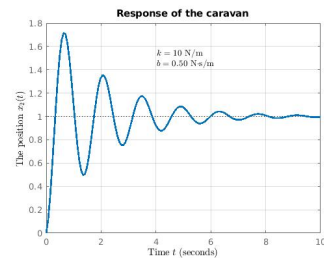
The students were given the values  $m = 0.50 \text{ kg}$  and  $a = 1 \text{ m/s}^2$  for which they ran a simulation of the model for two different combinations of the spring constant and the damping constant:

- $k = 10 \text{ N/m}$  and  $b = 0$  (no damping)
- $k = 10 \text{ N/m}$  and  $b = 0.50 \text{ N} \cdot \text{s/m}$  (with damping)

The students used MATLAB to plot the position  $x_2(t)$  of the caravan in the two cases (Figure D.3).



(a) Response of the caravan with no damping.



(b) Response of the caravan with damping.

Fig. D.3: MATLAB simulation

The case without damping obviously leads to an unacceptable model of the system. In contrast, the presence of damping ensures a smooth response of

the caravan. Many students now realize why a damper should be included as a part of modeling the linkage, even though it is not out there! Thus, by changing the value of  $b$  (and of  $k$  for that matter) we get two different designs and that will result in two different mathematical models. By referring to items 4 to 6 for both processes in Table D.1, we see that these are accomplished, as we are testing the models and comparing designs. The design process and the mathematical modeling process are therefore closely related to the extent that, in real-life engineering practice, separating the two processes would not be easy. It is therefore artificial to separate modules in mathematical modeling and engineering design in teaching situations, as engineering programs ought to correspond to and be compatible with realistic situations that the future engineers might encounter.

### 3.3 Example 2: The Connection between Mathematical Modeling and Engineering Design

To further illustrate the relation between the mathematical design process and the engineering design process, we mention here an example taken from a project by the first author introduced in the first-semester module "Models, Mechanics and Materials". Briefly, the problem is to find the internal forces in the three cables of the hanging lamp (see Figure D.4) and to redesign it if possible. The students themselves should provide realistic values for the weight and dimensions of the hanging lamp. They should also measure the lengths and diameters of the wires. The students should first make a model of the hanging lamp and then try to redesign it. This is an open problem with several solutions.



Fig. D.4: A hanging lamp

The modeling process consists of writing the equilibrium equations of the lamp using statics. The students discovered that they could not find the internal

forces in the three wires: They got two equations with three unknowns. By arriving at an indeterminate system of equations, the students then had a justification for why the middle wire was redundant. Some other students added the extra equation using deformation theory in the topic of strength of materials. In that way, they could determine the internal forces in the three wires by writing them down in matrix form. Changing the geometry and materials of the wires (i.e., design) leads to another system of equations (i.e., a new model). Other students chose to remove the middle wire, thus arriving at a consistent system of equations with a unique solution. Thus, the design the students choose will affect the mathematical model of the lamp. Conversely, the mathematical model of the lamp will influence its design and redesign. Here, we can see that the items of each pair in Table D.1 interact together in a fusion process to produce a solution to the problem. The main purpose of this course project is to relate topics from mathematics, specifically matrices and linear equations, to engineering mechanics and materials in the framework of Table D.1. We believe that through these kinds of course projects, mathematics teaching will be more motivating for the students, so they can see the relevance of the mathematical topics they encounter in their study program.

## 4 Discussion and Conclusion

In the paper, we have used Table D.1, which incorporates the engineering design and mathematical modeling processes as a theoretical framework for two student projects. The items in the table can be identified in the processes the students go through in two design projects. Here we also saw that the items in both the mathematical modeling process and the engineering design process became visible. We believe that this identification strengthens the argument that engineering mathematics should be taught in an engineering context, through well-designed teaching situations that allow engineering students to work with real-life problems. As stated in the introduction, design engineers work on projects that involve adapting and using engineering and mathematical techniques, and in reality, these are intertwined. We also believe that this strategy can be generalized to other situations where STEM integration is involved.

## References

- [1] A. Kolmos, J. E. Holgaard, and B. Dahl, "Reconstructing the aalborg model for pbl," *PBL across cultures*, vol. 289, 2013.
- [2] S. Barge, "Principles of problem and project based learning-the aalborg pbl model. aalborg university," 2010.
- [3] I. Askehave, H. L. Prehn, J. Pedersen, and M. T. Pedersen, "Pbl: Problem-based learning," *Aalborg University*, 2015.
- [4] J. Härterich, C. Kiss, A. Rooch, M. Mönnigmann, M. Schulze Darup, and R. Span, "Mathepraxis—connecting first-year mathematics with engineering applications," *European Journal of Engineering Education*, vol. 37, no. 3, pp. 255–266, 2012.
- [5] M. Blomhøj and T. H. Jensen, "Developing mathematical modelling competence: Conceptual clarification and educational planning," *Teaching mathematics and its applications*, vol. 22, no. 3, pp. 123–139, 2003.
- [6] S. Tayal, "Engineering design process," *International Journal of Computer Science and Communication Engineering*, vol. 18, no. 2, pp. 1–5, 2013.
- [7] D. Dowling, R. Hadgraft, A. Carew, T. McCarthy, D. Hargreaves, C. Baillie, and S. Male, *Engineering your future: an Australasian guide*, 4th ed. John Wiley & Sons, 2020.
- [8] R. C. Hilborn *et al.*, *Chaos and nonlinear dynamics: an introduction for scientists and engineers*. Oxford University Press on Demand, 2000.
- [9] R. C. Hibbeler, *Engineering Mechanics Dynamics*. Pearson Education, 2017.



# Paper E

Inquiry-Based Teaching in Engineering: The Case of  
"Transfer Functions"

IMAD ABOU-HAYT

Aalborg University, Denmark, imad@plan.aau.dk

BETTINA DAHL

Aalborg University, Denmark, bdahls@plan.aau.dk

CAMILLA ØSTERBERG RUMP

University of Copenhagen, Denmark, cr@ind.ku.dk

This paper has been submitted to the International Journal of Mathematical Education in Science & Technology. It is under review.



© 2020 Imad Abou-Hayt

*The layout has been revised.*



# Abstract

*Transfer functions are convenient representations to analyze cause-and-effect relationships of linear time-invariant dynamic systems. Traditionally, transfer functions are introduced using the Laplace transform. In this paper, the authors offer an inquiry-based learning method to represent transfer functions without formally using the full machinery of Laplace transforms. The method is used in an introductory engineering course on system modeling and simulation at Aalborg University, Denmark. The paper also presents an initial assessment of the experiences gained from implementing inquiry-based learning in the course. We conclude with a discussion of the impact of CAS tools on mathematics and engineering science teaching and learning.*

**Keywords:** Laplace transforms; transfer functions; modeling and simulation; MATLAB; Simulink

## 1 Introduction

Transfer functions are compact representations linear time-invariant dynamical systems where the governing differential equations become algebraic expressions that can be manipulated or combined with other expressions. They are used in block diagrams to describe the cause and effect relationships throughout the system.

The purpose of this paper is to present a method of teaching the topic "transfer functions" without explicitly introducing the Laplace transform, upon which the classical definition of a transfer function depends. Inquiry-based learning is chosen as a didactical model to make it possible for the students to discern the important features of a transfer function, using *learning-by-doing* computer experiments.

The first author of this paper is involved in teaching the course "System Modeling and Simulation", given to 5<sup>th</sup> semester students of the study program "Sustainable Design" at Aalborg University, Denmark. According to the syllabus of the study program, the course "System Modeling and Simulation" should include topics such as transfer functions of commonly used engineering systems and the simulation of mathematical models using MATLAB and Simulink<sup>1</sup>, among other things.

---

<sup>1</sup>Matlab and Simulink are registered trademarks of the software company MathWorks, <https://www.mathworks.com>

Our research methodology consisted of observing the student group discussions during the exercise sessions and the students' responses in the class. This allowed us to obtain a great deal of information about the whole teaching project related to the different representations of a dynamic system.

## 2 The Laplace Transform

the Laplace transform is a widely used integral transform that has important applications in many areas of mathematics, such as probability theory. In physics and engineering, it is used in the analysis of linear time-invariant dynamic systems such as electrical circuits, harmonic oscillators, optical devices and mechanical systems.

In introductory engineering courses on modeling, simulation and control of dynamic systems, the starting point is usually the development of appropriate mathematical models. These models usually lead to linear differential equations with constant coefficients. The method of Laplace transforms is a powerful tool to solve these equations, since it relies on algebra, rather than calculus-based methods.

A Laplace transform is a mapping between the time domain and the domain of the complex variable  $s$ . It is defined by [1, p. 80]

$$F(s) = \mathcal{L}(f(t)) = \int_0^{\infty} f(t)e^{-st} dt \quad (\text{E.1})$$

Laplace transforms are commonly used to solve the modeled differential equations, that involve functions of time  $t$ , by transforming them into algebraic equations, which involve the complex variable  $s$ . The algebraic equations, being much easier to solve than the original differential equations, are then transformed back to the time domain, using the inverse Laplace transform, Fig. E.1.

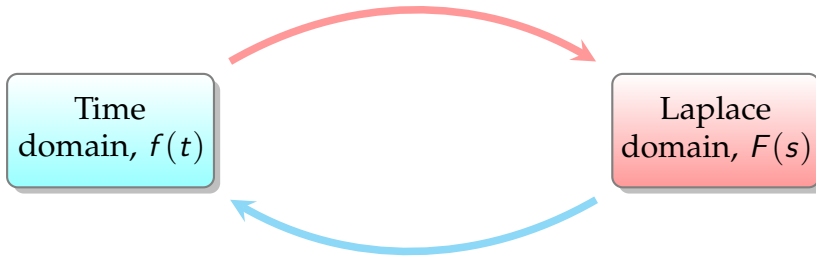


Fig. E.1: The operations involved in the Laplace transformation method

The Laplace transform methods provide a systematic approach for solving an ordinary differential equation and obtaining the dynamic response of the system the differential equation represents. This approach can be summarized as [2, p. 60]

1. Take the Laplace transform of every term of the differential equation and incorporate the initial conditions.
2. Using the result from step 1, solve for the Laplace transform of the dynamic variable,  $Y(s)$ .
3. Obtain the system's dynamic response by taking the *inverse* Laplace transform,  $y(t) = \mathcal{L}^{-1}\{Y(s)\}$ .

The critical step 3 usually yields an expression  $Y(s)$  that seldom appears in Laplace transform tables. The procedure required here is to decompose the function  $Y(s)$  into so-called partial fractions in order to determine the time-response function  $y(t)$ . This is yet another technique to be mastered in order to solve a differential equation by the Laplace transform.

Thus, the Laplace transform method offer an alternative approach for solving linear differential equations, even though it could prove tedious and time-consuming. In fact, the usual approach to solve linear differential equations is to assume a solution in the time domain. This is typically the first approach presented to most engineering students.

Besides being a method to solve differential equations, the Laplace transform is also used in the definition of a transfer functions: [1, p. 87]:

**Definition.** The transfer function of a linear system is defined as the ratio of the Laplace transform of the output and the Laplace transform of the input, *assuming zero initial conditions*.

The transfer function is thus an algebraic representation of the differential equation describing the system. It is used to calculate the response of a system to a given input. Referring to the block diagram in Fig. E.2, the output  $Y(s)$  is equal to the product of the input  $R(s)$  and the transfer function  $G(s)$ , i.e.

$$Y(s) = R(s) \cdot G(s) \tag{E.2}$$

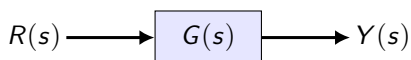


Fig. E.2: A block diagram representing a transfer function

### 3 A Brief History of the Laplace Transform

The Laplace transform is named after the French mathematician and astronomer Pierre-Simon Laplace (1749-1827), who used a similar transform (now called the z-transform) in his work on probability theory [3].

Well before the work of Laplace, however, Leonhard Euler (1707-1783) had studied integrals of the form  $\int_0^\infty f(t)e^{-at} dt$  and  $\int f(t) t^a dt$  as solutions of differential equations, but did not pursue this topic very far.

The Italian mathematician and astronomer Joseph Louis Lagrange (1736-1813), who succeeded Euler as the director of mathematics at the Prussian Academy of Sciences in Berlin, began to study integrals of the form  $\int_0^\infty f(t)e^{-at} a^t dt$  in connection with his work on integrating probability density functions. Laplace was the next person to seriously work on this topic and took a critical step forward by applying the idea of a "transformation" rather than just looking for a solution in the form of an integral. Specifically, he looked for solutions of the following equation:  $\int t^s \phi(t) dt = F(s)$ . In 1809, Laplace extended his transform to find solutions that diffused indefinitely, giving the world the Laplace transformation as we know it today [4]. However, the transformation was not given a true physical meaning until the English mathematician and electrical engineer Oliver Heaviside (1850-1925) came up with the same equation on his own in the 1880s. Heaviside invented operational calculus, which is a new method using the operator D notation, that allowed him to transform difficult differential equations into simple algebraic equations.

The current widespread use of the Laplace transform came about soon after

World War II although it had been used in the 19th century by Abel, Lerch, Heaviside and Bromwich [5].

In physics and engineering, it is used in the analysis of linear time-invariant systems such as dc motors, optical devices and mechanical systems. In such analysis, the Laplace transform is often interpreted as a transformation from the time-domain, in which inputs and outputs are functions of time, to the frequency-domain, where the same inputs and outputs are functions of the complex angular frequency, in radians per unit time.

## 4 The Didactical Challenges in Teaching Transfer Functions

The aim of this section is to identify and analyze some of the theoretical and didactical challenges in teaching the topic "transfer functions of linear dynamic systems", given the time limitations of the course and the various backgrounds of the students.

We rely on the paradigm design-based research (DBR) [6], which can help us understand the relationships among the didactical model, designed artifact and practice. DBR itself can be regarded as a mixture of empirical educational research and a theory-driven design of learning environments. It is an important methodology for understanding how, when and why educational innovations work in practice. In our case, DBR involves the design of a theoretically-inspired learning environment, to directly address a local problem, namely the challenges in the teaching of transfer functions.

Thus, before "designing" teaching situations in the subject, we carried out a preliminary analysis, consisting of two dimensions:

1. An epistemological and cognitive analysis of the mathematical and engineering content that will hopefully helps us in finding suitable teaching situations.
2. An institutional analysis of the context in which the teaching situations occur.

Regarding item 1, the curriculum of the course includes a short introduction to the Laplace transform, given that the concept "transfer function" relies on the terminology of the transform. Looking at some standard textbooks on

modeling and control dynamic systems, such as [7] and [1], they start with a somewhat comprehensive introduction to the Laplace transforms before defining transfer functions. Accordingly, the students have to learn another method of solving differential equations, in addition to the one they have had in their mathematics course, namely the method of undetermined coefficients [8, p. 131]. Moreover, this introduction to the Laplace transform involves decomposition into partial fractions in order to eventually arrive at the time-domain solution of the differential equation. This is another didactic variable to consider, given that partial fraction decomposition is an unduly tedious process.

The course also includes numerical simulations of dynamic systems using MATLAB and Simulink. The good news is that these simulations are based on the time-domain differential equations and not on the Laplace transform theory [9]. It is interesting to note that Simulink employs the icons shown in Fig. E.3 to represent standard *time-domain* inputs (Fig. E.4) to a system, even though the system itself is represented as a transfer function, which is a Laplace-domain concept. This clearly shows that, in Simulink, transfer functions are just *formal representations* of the underlying time-domain differential equations. In that regard, the authors believe that it is not sound, neither mathematically nor pedagogically, to mix the two domains in a block diagram, which of course is a differential equation in disguise. We suspect that this mixing of time-domain and Laplace domain in Simulink could be quite confusing for our students.



Fig. E.3: Examples of input signals in Simulink

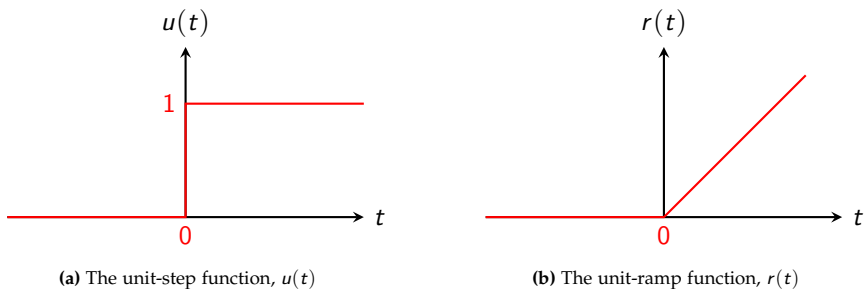


Fig. E.4: Examples of standard input time functions



The authors find Simulink's use of the Laplace notation  $\frac{1}{s}$  for the integration process (Fig. E.5) totally misleading for two reasons:

1. The input signal, the numerical integration itself *and* the output signal are all in the time domain.
2. The expression  $\frac{1}{s}$  is in fact the Laplace transform of the unit-step function (Fig. E.4a):

$$u(t) = \begin{cases} 0 & \text{if } t < 0 \\ 1 & \text{if } t \geq 0 \end{cases} \quad (\text{E.3})$$

rather than the integral of a function. In fact, according to standard Laplace transform tables, such as the one in [1, p. 81], the time-function corresponding to  $\frac{1}{s}$  is not an "integrator" but the unit-step function or even the constant 1.

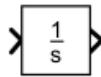


Fig. E.5: The Simulink Integrator block

Again, using the same expression,  $\frac{1}{s}$ , to represent two different objects can give rise to misconceptions and misinterpretations among the students, not to mention the difficulty facing the instructors themselves to explain the difference.

In the Laplace transform theory, the differentiation theorem states that the Laplace transform of  $\dot{y}$  is equal to  $sY(s) - y(0)$ , and the Laplace transform of  $\ddot{y}$  is  $s^2Y(s) - sy(0) - \dot{y}(0)$  and so on for higher derivatives. Now, since all initial conditions  $y(0)$ ,  $\dot{y}(0)$  and  $\ddot{y}(0)$  are assumed to be zero for a transfer function, we conclude that multiplying by the  $k$ th power of the Laplace variable  $s$  in the Laplace domain corresponds to the  $k$ th derivative in the time domain. We can therefore simplify the analysis of the governing mathematical model by defining the differential operator or "D operator" as

$$D \equiv \frac{d}{dt} \quad (\text{E.4})$$

Using this notation, the time derivatives in a differential equation can be written as powers of the operator  $D$ : for example,  $Dy = \dot{y}$ ,  $D^2y = \ddot{y}$ . We can then replace the differential operator  $D$  in the differential equation with  $s$  to

obtain the transfer function and vice versa. As an example, if a system is modeled by the differential equation,

$$\ddot{y} + 8\dot{y} + 10y = 4u \quad (\text{E.5})$$

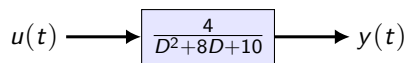
where  $u$  is the input and  $y$  is the output, then we can get the output-to-input ratio  $\frac{y(t)}{u(t)}$  by applying the  $D$  operator

$$\frac{y(t)}{u(t)} = \frac{4}{D^2 + 8D + 10} \quad (\text{E.6})$$

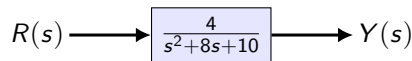
Finally, replacing the operator  $D$  with  $s$  yields the transfer function of the system

$$G(s) = \frac{4}{s^2 + 8s + 10} \quad (\text{E.7})$$

These results are also shown in block diagram form (Fig. E.6).



(a) A block diagram in the time-domain



(b) A block diagram in the Laplace-domain

Fig. E.6: Two representations of the differential equation E.5

We can therefore use transfer functions to analyze the system response using Simulink, *without* relying on the Laplace transform theory. A full coverage of the Laplace transform theory may not be necessary for the students to grasp the concept of transfer function. However, for the sake of completeness, we posted teaching materials on the Laplace transform methods to the course website so that the students have access to a more comprehensive introduction to the subject.

Regarding item 2 in this section, our department decided that the duration of a 5 ECTS point course, like ours, is 10 weeks and the class meets once a week. This time constraint could entail that the instructor acts as decision maker and problem solver, rather than an executor of the course syllabus as an algorithm. The students have had introductory courses in linear differential equations, dynamics and thermodynamics but not in fluid mechanics or electrical circuits. Moreover, the students were never introduced to MATLAB

before, so an introduction to MATLAB and Simulink in the beginning of the course is necessary. The time allocated for the course seems to be an obstacle for a full coverage of the Laplace transform, on which the concept of transfer function relies, since modeling of major engineering systems and simulation using MATLAB and Simulink are core elements of the syllabus of the course. Therefore, we need to find a way that avoids the classical introduction to the Laplace transform theory and which could lead to the learning outcomes of the topic transfer functions.

## 5 Didactical Model: Inquiry-Based Learning

The next step in the design of the teaching situations is the choice of a didactical model, i.e., a research-based theoretical platform within which we develop and analyze the teaching situations. In general, a didactical model can be selected from two major approaches to education: Deductive and inductive methods.

Engineering and science courses are traditionally taught deductively [10]: The instructor introduces a topic by giving lectures followed by illustrative examples. The students are then asked to do exercises or homework that are similar to the examples shown, and finally the instructor tests their abilities to do the same kind of problems on exams. In deductive teaching, the motivation the students usually get is that the topic will be relevant later in another course or in their career.

Deductive teaching is a traditional education method where the knowledge is directly transferred to students, the teacher is the sole distributor of knowledge and the student is the passive receiver of this knowledge. Under these conditions, the learner is the object of the learning process, but not the subject.

In contrast to this method, inductive teaching starts with observations for the students to interpret, a case study to analyze or a real-world problem to solve. In their attempts to solve the problem, the students are motivated to learn a method or principle because they generate a desire to learn and a need to know [11]. They are *then* presented with the needed information or guided to discover it for themselves.

In inductive learning, the instructor plays many important roles such as facilitating learning, clarifying concepts and even lecturing: An inductive teaching method does not mean total absence of lectures and complete reliance on self-discovery.

It should be noted that inductive teaching and learning is a family of instructional methods that includes inquiry-based learning, problem-based learning, project-based learning and Brousseau's theory of didactical situations. All these methods can be characterized as being *constructivist* approaches in the sense that students construct new knowledge for themselves by adjusting or rejection their prior beliefs and misconceptions in the light of the evidence provided by the experiences that are orchestrated by the instructor.

Since our aim is to trigger the students' curiosity about the different representations of a dynamic system, we choose inquiry-based learning as our *tentative* didactical model: Activating a students curiosity is, we believe, a far more important and complex goal than mere lecturing on the topic. We want the students to develop their own skills as content-area experts in MATLAB simulations and problem solving and guide them through interactive lectures and discussions. In fact, "the only strategy that is not consistent with inquiry-guided learning is the exclusive use of traditional lecturing" [12, p. 10].

Despite its complexity, inquiry-based learning can be easier on teachers, partly because it transfers some responsibilities from teachers to students, but mostly because releasing authority engages students and allows them to analyze and interpret results and formulate conclusions.

Another reason of choosing inquiry-based learning is that several published research articles concluded that it is generally more effective than traditional instruction for achieving a variety of learning outcomes [13, 14] and in improving the students' academic achievement, process skills and analytic abilities [15]. Moreover, it is generally adopted and "approved" by policy makers, such as the European Commission:

"Inquiry-based science education (IBSE) has proved its efficacy at both primary and secondary levels in increasing childrens and students' interest and attainment levels while at the same time stimulating teacher motivation. IBSE is effective with all kinds of students from the weakest to the most able and is fully compatible with the ambition of excellence." [16, p. 2]

## 6 Implementation and Analysis of the Didactical Model

We now need to implement and analyze our didactical model by testing it in the classroom, using a set of exploratory questions the purpose of which is to enable the students to capture the essential aspects of the topic "transfer

functions".

We started by asking the students to do computer experiment with the Simulink "Integrator" block using different input signals, such as constants (Fig. E.7), ramps and sines. The purpose here is to allow the students to discover for themselves how the Integrator "operates" on the input signals to "transform" them to the output signals. Again, the authors find Simulink's use of the Laplace notation  $\frac{1}{s}$  for the integration process totally misleading, given the fact that the input signal, the numerical integration itself *and* the output signal are all in the time domain.

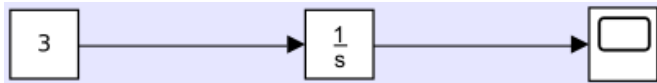


Fig. E.7: Experimenting with the Simulink Integrator block

We then started a dialogue with the students about the various definitions and representations of a function in mathematics. Some students answered that a function can be given by an equation or a table. We then intervened and asked the following question: "How do you use the square root function  $\sqrt{\cdot}$ , found in many calculators?" The purpose of this question is to prepare the students to a *new* definition of a function: It takes an input and *transforms* it to an output.

The conversations in the class culminated in a block diagram (Fig. E.8) where the function  $f$  operates on the independent variable  $x$ , now called the *input*, to produce the dependent variable  $y$ , called the *output*. The purpose of initiating the dialogue in the class is to prepare the students to acquire a new knowledge of transfer functions by building on their previous knowledge of functions in mathematics.

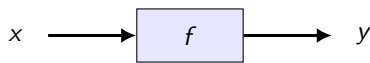


Fig. E.8: A block diagram representing a function

We then define the the " $D$  operator" as

$$D \equiv \frac{d}{dt} \tag{E.8}$$

and used interactive lecturing to introduce the time derivatives in a differential equation as powers of the operator  $D$ :  $Dy = \dot{y}$ ,  $D^2y = \ddot{y}$ , etc. (Fig. E.9).

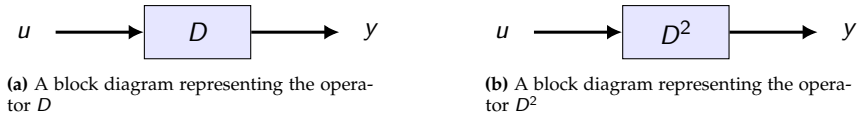


Fig. E.9: Two block diagrams representing the first and second derivatives

The students were then given a series of exercises that should be done in groups. The purpose of these exercises is to make it possible for them to "discover" the similarity between the operator  $D$  in differential equations (Fig. E.10) and the complex variable  $s$  in a simulink block diagram. Specifically, we asked the students to solve the differential equation in Fig E.10b, *with pen and paper*, using the method they learned in the 1<sup>st</sup> semester, simulate the corresponding block diagram in simulink (Fig. E.11) and compare the results. We posted a video on nonhomogeneous second-order linear differential equations on the course website to remind the students of the method they have learned in their mathematics course.

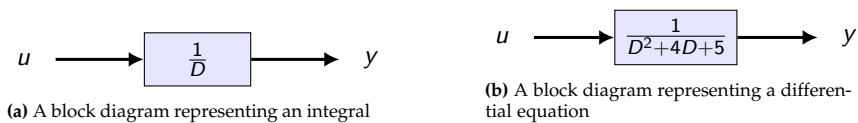


Fig. E.10: Input-output block diagrams

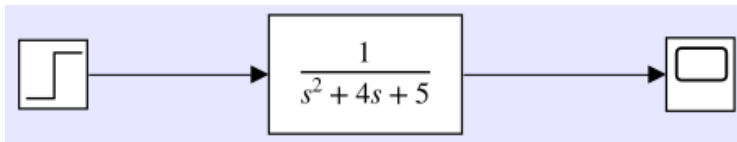


Fig. E.11: The block diagram in Simulink

Realistic problem solving improves the student's learning processes: "One gain *more* from solving a problem than getting to know the answer obtained" [17]. Thus, to make it possible for the students to discover the practical relevance of the integrator block in Simulink and see it "in action", we gave them a problem from a real-life situation:

**Problem.** *In a cold January morning with an ambient temperature of  $T_a = -10^\circ\text{C}$ , your instructor bought a cup of coffee at a local coffeehouse near campus. The coffee is initially at a temperature of  $80^\circ\text{C}$  when he received it, and it was in a capped to-go*

cup with a total thermal resistance  $R = 0.25^\circ\text{C} \cdot \text{s}/\text{J}$  (Fig. E.12). The coffee has a total thermal capacitance of  $C = 1237 \text{ J}/^\circ\text{C}$ .

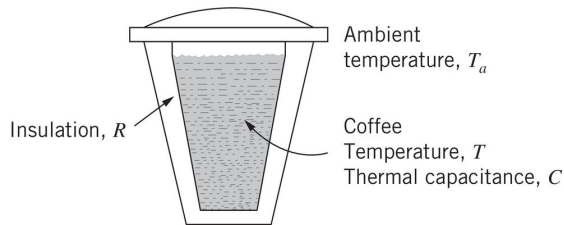


Fig. E.12: A capped to-go coffee cup

1. Derive the mathematical model of the coffee cup.
2. Implement the mathematical model in Simulink.
3. It took your instructor 10 min to walk from the coffeehouse to his office. Use Simulink to determine the temperature of the coffee when he entered the building.
4. What would you suggest to increase the temperature of the coffee when he entered the building?

The students now know that in order to use Simulink they should replace the differential operator  $D$  in the input-output ratio with the "symbol"  $s$ . Therefore, based on the students *own* experience gained from solving the exercises and the problem given, we gave the students our *own operational* definition of a transfer function, in the final wrap-up of the lesson.

**Definition.** The transfer function of a linear system is obtained from the input-to-output ratio by replacing the operator  $D$  in  $G(D)$  (Fig. E.13a) with the complex variable  $s$  (Fig. E.13b).

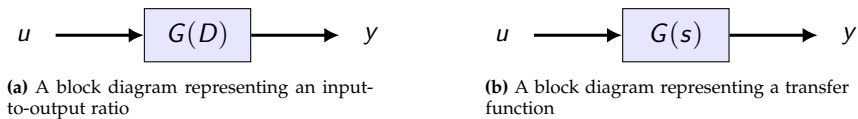


Fig. E.13: Defining the transfer function

The motivation behind this definition is to get the students acquainted with Simulink terminology in simulating a dynamic system: Under the hood, it is precisely the time-domain input-to-out ratio (Fig. E.13a) that is implemented in Simulink!

## 7 Evaluation of the Didactical Model

In this phase we to take a step back and evaluate our didactical model. Did it fulfill our methodological ambitions and needs and was it a relevant methodological choice for solving the didactical challenge? Did it contribute to the students' learning?

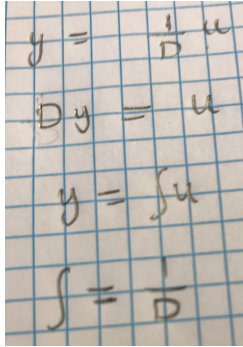
The course is offered once per year and ran for the first time in Autumn 2019. We have therefore no other didactical model to compare with, in order to choose one for future use. Therefore, we can only evaluate the didactical model itself and the students' learning outcomes, through internal and external validation respectively.

Internal validation refers to the comparison of the analysis of the didactical challenge of teaching the topic transfer functions with the actual implementation of the chosen didactical model, namely, Inquiry-Based Learning. In that regard, the model did actually solve the problem of introducing transfer functions without a lengthy lecturing on the Laplace transforms: In fact, we just used a single teaching session to do the activities and the exercises mentioned previously, among the ten teaching sessions allocated to the course.

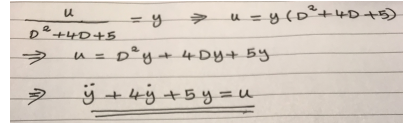
External validation is based on the observation and the documentation of the students' answers to the exercises given as well their questions during the exercise sessions. Even though some students needed more guidance than others, all succeeded in doing the exercises at the end. Actually, the main problem was in the assigned reading of a document on the Laplace transforms. Many found it hard to understand. This is a serious issue that should be addressed in the next iteration of the course. The problem could perhaps be due to the fact that reading a mathematical text is usually different from the traditional way the students are taught to read textbooks in general. In the next iteration of the course, we plan to produce a series of short video lessons on the Laplace transforms instead of the lecture notes used.

Below we present some excerpts of students' solutions to the exercises.



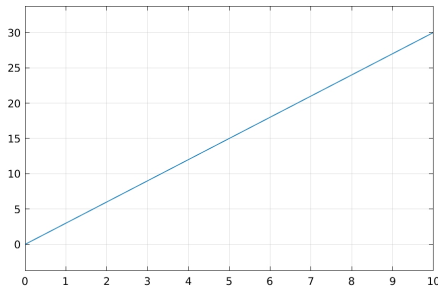


(a) A student solution of the integrator block in Fig E.10a

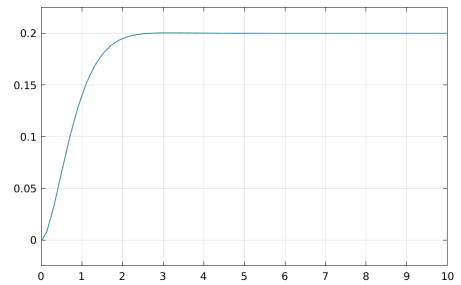


(b) A student solution of the block diagram in E.10b

Fig. E.14: Examples of student solution of Fig. E.10



(a) A student solution of the integrator block in Fig E.7



(b) A student simulation of the block diagram in Fig. E.11

Fig. E.15: Examples of student simulations in Simulink

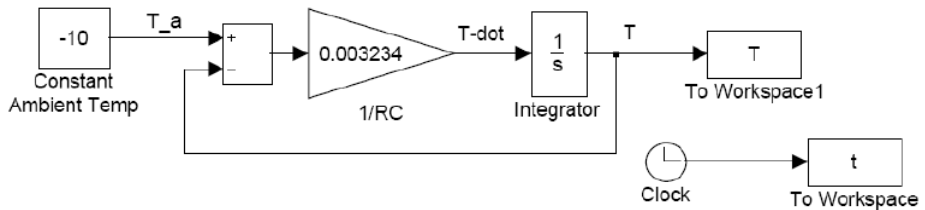


Fig. E.16: A student's Simulink block diagram of the coffee cup problem

The Simulink block diagram of the coffee cup problem (Fig. E.16) shows that

the governing differential equation of the mathematical model can be *directly* implemented in Simulink, using the integrator block and without the need to find the transfer function of the system first.

Moreover, the exercises given seem to suggest that the students have captured the simple idea that a transfer function is just *another* representation of a differential equation describing a dynamic system.

## 8 Discussion and Conclusion

Inquiry-based learning methods have been used extensively in the sciences [18–20], but, surprisingly enough, to a lesser extent in engineering [21, 22]. We have no evidence that the inquiry methods can be completely implemented in an engineering program or even in a single engineering course. However, this paper shows that it can be *possible* to base teaching of a topic or a part of an engineering course on inquiry-based learning. The paper also shows that our "model" of the instructor as a transmitter or even a facilitator of knowledge does not completely correspond to the manifold of activities he or she carry out: The instructor is also a director of the didactic process, a problem-solver, a designer and a decision maker.

As in mathematical modeling, didactical models are rarely perfect and complete representations of the complex reality in the classroom, such as the students' heterogeneity and the variety of knowledge to be studied. These models should take into account the kind of help and guidance the instructor should give to the class, given that students differ in background, skills and knowledge and many of them need tailored guidance in order to learn.

When two models of the same didactical problem are available, the instructor may want to compare them with an eye to choosing one for future use. Such a comparison will always contain the instructor's individual interpretation of texts, the syllabuses and the teaching aims in the discipline, since there are many different aspects on which the decision of the instructor can be based. These aspects can also include the instructor's experience, beliefs and knowledge.

Based on the results of the DBR study the authors' experience and knowledge as instructors, we believe that using the Laplace transform method to obtain the system response does not impart new knowledge of the solution of a differential equation or the behavior of the dynamic system, just like using partial fractions to decompose an indefinite integral does not teach anything

new about the concept of integration by doing it by hand. The method is cumbersome and time-consuming, given the limited time allocated to the course.

If it is the case that we could find the inverse Laplace transform of an expression without the need to simplify, engineering textbooks on the subject would not need to cover partial fractions in their introduction to Laplace transforms.

And why are we asking a student to find the inverse Laplace transform in the first place? What is being tested is the students ability to have memorized and then apply a repetitive computational process, like a computer does. They just reproduce the process and get an answer. If it is the right answer, all we have done, as instructors, would be a verification that we have trained a well-prepared student to be replaced by a computer. The problem is with the question. We should train the students to understand when and where to apply an engineering or mathematical concept, to be able to break a question down and identify what aspects are involved and what methods need to be applied. Therefore, we should devise problems that test these skills.

To use the terminology of the anthropological approach developed by Chevalard [23], engineering education should reconsider the study of a *domain*, taking the obsolescence of traditional techniques into account and to recognize new *techniques* as components of new *praxeologies* for this domain. Thinking of new techniques linked to the use of CAS tools and of their possible epistemic value is not easy because mathematical culture is traditionally associated with paper-and-pencil techniques and may be not accustomed to the idea that other tools can contribute to students' learning [24].

Solving linear differential equations with the Laplace transform method is a painstaking paper-and-pencil technique that retain little pragmatic value since this method is challenged by "mouse click" techniques in Simulink. However, paper-and-pencil techniques in solving linear differential equations in the time domain do not become obsolete because of the ease of using Simulink or any other CAS tool. On the contrary, they have an important epistemic value, and play a crucial role in the conceptualization of differential equations and in the time evolution of dynamic systems.

In our course, we did not introduce the  $D$ -operator to generate better results; we did it to prepare our students for the world as it is, not as it was. Therefore, we do not anticipate that the students do engineering science and mathematics only by using CAS. Rather, we expect a "CAS-assisted" practice that is intertwined with paper-and-pencil techniques. Thus, we should regard the use of simulations in Simulink as calling for an integration between new techniques and paper-and-pencil methods.

Since the students were introduced to time-domain differential equations in their first year, we therefore stayed in the time domain in analyzing differential equations and only used MATLAB and Simulink in numerical simulations. Furthermore, while it is true that MATLAB and Simulink often use transfer functions, which use the complex variable  $s$ , to *represent* the differential equations, their numerical solutions are based on the time-domain differential equations and *not* on the Laplace transform. For the sake of *representing* dynamics systems, we can simply interchange the  $D$  and  $s$  symbols to get the transfer function in order to use Simulink.

## 9 Epilogue

It is not the intention of the authors to undermine the importance of the Laplace transform in mathematics, physics and engineering. On the contrary, the Laplace transform is one of the tool used by scientists and researchers in finding the solution to their problems. In fact, [25] reviewed 25 research papers in various disciplines and discussed how the Laplace transform was used to solve some research problems.

## References

- [1] R. C. Dorf and R. H. Bishop, *Modern control systems*. Pearson, 2011.
- [2] J. L. Schiff, *The Laplace transform: theory and applications*. Springer Science & Business Media, 2013.
- [3] M. A. Deakin, "The development of the Laplace transform, 1737–1937," *Archive for History of Exact sciences*, vol. 25, no. 4, pp. 343–390, 1981.
- [4] D. J. Struik, *A concise history of mathematics*. Courier Corporation, 2012.
- [5] M. A. Deakin, "The development of the Laplace transform, 1737–1937 ii. poincaré to doetsch, 1880–1937," *Archive for History of Exact Sciences*, vol. 26, no. 4, pp. 351–381, 1982.
- [6] F. Wang and M. J. Hannafin, "Design-based research and technology-enhanced learning environments," *Educational technology research and development*, vol. 53, no. 4, pp. 5–23, 2005.
- [7] K. Ogata, *System dynamics*. Prentice Hall Upper Saddle River, NJ, 1998, vol. 3.

- [8] W. E. Boyce, R. C. DiPrima, and D. B. Meade, *Elementary differential equations*. John Wiley & Sons, 2017.
- [9] W. J. Palm, *Introduction to MATLAB for Engineers*. McGraw-Hill New York, 2011.
- [10] M. J. Prince and R. M. Felder, "Inductive teaching and learning methods: Definitions, comparisons, and research bases," *Journal of engineering education*, vol. 95, no. 2, pp. 123–138, 2006.
- [11] M. A. Albanese, S. Mitchell *et al.*, "Problem-based learning: A review of literature on its outcomes and implementation issues," *Academic Medicine-Philadelphia-*, vol. 68, pp. 52–52, 1993.
- [12] V. Lee, "Teaching and learning through inquiry: A guidebook for institutions and instructors," 2004.
- [13] D. A. Smith, "A meta-analysis of student outcomes attributable to the teaching of science as inquiry as compared to traditional methodology." 1997.
- [14] D. L. Haury, *Teaching science through inquiry*. ERIC Clearinghouse for Science, Mathematics, and Environmental Education , 1993.
- [15] J. A. Shymansky, L. V. Hedges, and G. Woodworth, "A reassessment of the effects of inquiry-based science curricula of the 60's on student performance," *Journal of Research in Science Teaching*, vol. 27, no. 2, pp. 127–144, 1990.
- [16] E. C. H. L. G. on Science Education, E. C. Science, and Economy, *Science education now: A renewed pedagogy for the future of Europe*. Office for Official Publications of the European Communities, 2007, vol. 22845.
- [17] M. Bosch and C. Winsløw, "Linking problem solving and learning contents: the challenge of self-sustained study and research processes," *Recherches en Didactique des Mathématiques*, vol. 35, no. 2, pp. 357–399, 2015.
- [18] L. C. McDermott *et al.*, *Physics by Inquiry: An Introduction to Physics and the Physical Sciences, Volume 1*. John Wiley & Sons, 1995.
- [19] B. Thacker, E. Kim, K. Trefz, and S. M. Lea, "Comparing problem solving performance of physics students in inquiry-based and traditional introductory physics courses," *American Journal of Physics*, vol. 62, no. 7, pp. 627–633, 1994.

- [20] R. M. Schlenker and K. R. Schlenker, "Integrating science, mathematics, and sociology in an inquiry-based study of changing population density," *Science Activities*, vol. 36, no. 4, pp. 16–19, 2000.
- [21] N. Buch and T. Wolff, "Classroom teaching through inquiry," *Journal of professional issues in engineering education and practice*, vol. 126, no. 3, pp. 105–109, 2000.
- [22] T. F. Stahovich and H. Bal, "An inductive approach to learning and reusing design strategies," *Research in Engineering Design*, vol. 13, no. 2, pp. 109–121, 2002.
- [23] Y. Chevallard, "La recherche en didactique et la formation des professeurs: problématiques, concepts, problèmes," *Actes de la Xe Ecole d'Eté de didactique des mathématiques (Houlgate 18-25 aout 1999)*, pp. 98–112, 1999.
- [24] J.-B. Lagrange, "Using symbolic calculators to study mathematics," in *The didactical challenge of symbolic calculators*. Springer, 2005, pp. 113–135.
- [25] K. Reddy, K. Kumar, J. Satish, and S. Vaithyasubramanian, "A review on applications of laplace transformations in various fields," *Journal of Advanced Research in Dynamical and Control Systems*, vol. 9, pp. 14–24, 01 2017.



ISSN (online): 2446-1628  
ISBN (online): 978-87-7210-897-1

**AALBORG UNIVERSITY PRESS**