



AALBORG UNIVERSITY
DENMARK

Aalborg Universitet

The Roles of Finance functions, Management Accounting, and Lean

Nielsen, Henrik

DOI (link to publication from Publisher):
[10.5278/vbn.phd.eng.00031](https://doi.org/10.5278/vbn.phd.eng.00031)

Publication date:
2017

Document Version
Publisher's PDF, also known as Version of record

[Link to publication from Aalborg University](#)

Citation for published version (APA):
Nielsen, H. (2017). *The Roles of Finance functions, Management Accounting, and Lean*. Aalborg Universitetsforlag. <https://doi.org/10.5278/vbn.phd.eng.00031>

General rights

Copyright and moral rights for the publications made accessible in the public portal are retained by the authors and/or other copyright owners and it is a condition of accessing publications that users recognise and abide by the legal requirements associated with these rights.

- Users may download and print one copy of any publication from the public portal for the purpose of private study or research.
- You may not further distribute the material or use it for any profit-making activity or commercial gain
- You may freely distribute the URL identifying the publication in the public portal -

Take down policy

If you believe that this document breaches copyright please contact us at vbn@aub.aau.dk providing details, and we will remove access to the work immediately and investigate your claim.

**THE ROLES OF FINANCE FUNCTIONS,
MANAGEMENT ACCOUNTING AND LEAN**

**BY
HENRIK NIELSEN**

DISSERTATION SUBMITTED 2017



AALBORG UNIVERSITY
DENMARK

THE ROLES OF FINANCE FUNCTIONS, MANAGEMENT ACCOUNTING AND LEAN

by

Henrik Nielsen



AALBORG UNIVERSITY
DENMARK

Dissertation submitted

Dissertation submitted: 29-09-2017

PhD supervisor: Associate Prof. Thomas Borup Kristensen,
Aalborg University

Assistant PhD supervisor: Professor Poul Israelsen,
Aalborg University

PhD committee: Associate Professor Niels Sandalgaard (chairman)
Aalborg University
Professor Chris Chapman
Bristol University
Associate Professor Ivar Friis
Copenhagen Business School

PhD Series: Faculty of Engineering and Science, Aalborg University

Department: Department of Materials and Production

ISSN (online): 2446-1636
ISBN (online): 978-87-7210-075-3

Published by:
Aalborg University Press
Skjernvej 4A, 2nd floor
DK – 9220 Aalborg Ø
Phone: +45 99407140
aauf@forlag.aau.dk
forlag.aau.dk

© Copyright: Henrik Nielsen

Printed in Denmark by Rosendahls, 2017

Acknowledgements

This dissertation was written in the Department of Business and Management during the period from August 2014 to September 2017, and it is my humble contribution to research on the roles of finance functions, management control and Lean. I am very grateful that I had this opportunity.

Several important people deserve my gratitude. I would not have completed this work without the continuous encouragement and support of my two supervisors, Associate Professor Thomas Borup Kristensen and Professor Poul Israelsen. Thank you for your friendship, guidance, and debates during this endeavor. When times were rough, you were a source of true support. It has been an honor to work with you, and I hope that we can continue to collaborate. My colleagues at the MAC research group deserve my gratitude as well. Thank you for the discussions of ideas and research opportunities and for creating a stimulating work environment in the department.

Additionally, this dissertation has benefited significantly from my collaboration with Professor Larry Grasso at Central State Connecticut University. I thank you for your hospitality and our insightful conversations. I am also grateful for the conversations that I had with Professor Peter T. Ward at the Ohio State University, Professor Bob Emiliani at Central State Connecticut University, and Professor Kathleen Eisenhardt while I studied at Stanford University.

Many thanks also go to Deloitte, which provided financial support for the dissertation, and to the Knud Højgaards Fund, which helped to fund my research visit at Stanford University.

I would also like to thank my friends. You have believed in me and rooted for me throughout the three years. Finally, I thank my family. I am lucky to have you, and I dedicate this work to you.

Henrik Nielsen

1. INTRODUCTION	1
1.1 <i>THE ROLES OF FINANCE FUNCTIONS</i>	1
1.2 <i>LEAN AND MANAGEMENT CONTROL MECHANISMS.....</i>	3
1.3 <i>LEAN, MANAGEMENT ACCOUNTING PRACTICES, AND TIME COMPRESSION DISECONOMIES .</i>	4
2. DANSKE RESUMÉ.....	5
2.1 <i>ØKONOMIFUNKTIONENS ROLLER.....</i>	5
2.2 <i>LEAN OG MANAGEMENT CONTROL MECHANISMS</i>	10
2.3 <i>LEAN, ØKONOMISTYRINGSMODELLER OG TIME COMPRESSION DISECONOMIES.....</i>	11
3. EXTENDED ENGLISH SUMMARIES	14
3.1 <i>PAPER I: THE CHANGING ROLES OF FINANCE ORGANIZATIONS: A REVIEW AND ANALYSIS OF EMPIRICAL MANAGEMENT ACCOUNTING RESEARCH.....</i>	14
3.2 <i>PAPER II: THE RELATIONSHIPS BETWEEN FINANCE FUNCTION ROLES, BEHAVIORAL DIFFERENTIATION, AND PERFORMANCE.....</i>	16
3.3 <i>PAPER III: LEAN AND MANAGEMENT ACCOUNTANTS: SURVEY EVIDENCE OF THE ROLES OF FINANCE FUNCTIONS</i>	19
3.4 <i>PAPER IV: THE PERFORMANCE EFFECTS OF COMPLEMENTARY MANAGEMENT CONTROL MECHANISMS.....</i>	21
3.5 <i>PAPER V: THE RELATIONSHIPS BETWEEN LEAN MANUFACTURING, LEAN THINKING, MANAGEMENT ACCOUNTING, AND FIRM PERFORMANCE: IT IS ABOUT TIME</i>	24
4. DATA AND QUESTIONNAIRE ITEM SCALES	28
4.1 <i>PAPERS 2 AND 3 - DATA</i>	28
4.2 <i>FINANCIAL STATEMENT INFORMATION AS CONTROL AND ENDOGENOUS VARIABLES.....</i>	31
4.3 <i>PAPERS 2 AND 3- ITEMS AND SCALES</i>	31
4.3.1 <i>Paper 2- Items and scales</i>	35
4.3.2 <i>Paper 3 - Items and scales</i>	36
4.4 <i>PAPERS 4 AND 5 - DATA</i>	36
4.4.1 <i>Papers 4 and 5- Questionnaire items and scales</i>	39
4.4.2 <i>Paper 4: Items and scales</i>	39
4.4.3 <i>Paper 5- Items and scales</i>	41
5. METHOD	42
5.1 <i>THE HORIZONTAL DIMENSION.....</i>	44
5.2 <i>THE VERTICAL DIMENSION</i>	46

5.3 TO WHICH PARADIGM DOES THIS DISSERTATION BELONG?	47
6. REFERENCES	50
7. PAPER 1: THE CHANGING ROLES OF FINANCE ORGANIZATIONS – A REVIEW AND ANALYSIS OF EMPIRICAL MANAGEMENT ACCOUNTING RESEARCH	60
7.1 INTRODUCTION.....	62
7.2 METHOD AND DATA COLLECTION	65
7.3 METHODS, DATA ANALYSIS TECHNIQUES, RESEARCH SETTINGS, AND TOPICS	67
7.4 THE COMPETING VALUES FRAMEWORK	71
7.5 FINANCE ORGANIZATIONS’ ROLES AND THE CVF	75
7.6 SURVEY INSTRUMENT	85
7.7 DISCUSSION AND FUTURE RESEARCH.....	88
7.8 CONCLUSIONS AND LIMITATIONS	94
7.9 APPENDIX	96
7.10 REFERENCES	102
8. PAPER 2: THE RELATIONSHIPS BETWEEN FINANCE FUNCTION ROLES, BEHAVIORAL DIFFERENTIATION, AND PERFORMANCE.....	111
8.1 INTRODUCTION.....	113
8.2 LITERATURE REVIEW AND HYPOTHESES DEVELOPMENT	115
8.3 METHODS	128
8.4 EMPIRICAL RESULTS	145
8.5 DISCUSSION AND CONCLUSION.....	151
8.6 LIMITATIONS AND FUTURE STUDIES	154
8.7 APPENDIX I	155
8.8 LITERATURE	156
9. PAPER 3: LEAN AND MANAGEMENT ACCOUNTANTS: SURVEY EVIDENCE OF THE ROLES OF FINANCE FUNCTIONS	168
9.1. INTRODUCTION.....	169
9.2 BACKGROUND LITERATURE AND HYPOTHESES DEVELOPMENT	173
9.3. METHODS	189
9.4 EMPIRICAL TESTS AND RESULTS.....	201
9.5 DISCUSSION AND CONCLUSION.....	206
9.6 FUTURE RESEARCH AND LIMITATIONS.....	209

9.7 APPENDIX 1	210
9.8 APPENDIX 2	211
9.9 LITERATURE	213
10. PAPER 4: THE PERFORMANCE EFFECTS OF COMPLEMENTARY MANAGEMENT CONTROL MECHANISMS	226
10.1 INTRODUCTION.....	227
10.2 LITERATURE AND HYPOTHESES DEVELOPMENT	230
10.3 METHODS	240
10.4 EMPIRICAL TESTS AND RESULTS.....	254
10.5 DISCUSSION AND CONCLUSION	259
10.6 FUTURE RESEARCH AND LIMITATIONS.....	264
10.7 APPENDIX 1.....	265
10.8 LITERATURE	268
11. PAPER 5: THE RELATIONS BETWEEN LEAN MANUFACTURING, LEAN THINKING, MANAGEMENT ACCOUNTING AND FIRM PERFORMANCE – IT IS ABOUT TIME.....	278
11.1 INTRODUCTION.....	279
11.2 LITERATURE REVIEW AND HYPOTHESES DEVELOPMENT	285
11.3 METHODS	308
11.4 RESULTS.....	317
11.5 CONCLUSION.....	327
11.6 LIMITATIONS AND FUTURE STUDIES	332
11.7 REFERENCES	335

1. Introduction

My dissertation revolves around the roles of finance functions, Lean, and management control.¹ The initial inspiration for the dissertation was fostered during my master's program in management accounting at Aalborg University. I collaborated with five international firms all employing Lean manufacturing, in which I studied the roles of finance functions and management control. I was inspired by the interviews and observations that I had in the companies, and it felt natural that my dissertation shed light on these topics. The dissertation includes five papers which can be found in chapters 7-11. Unfortunately, there is some overlap between this short introduction and the papers, but it was simply not possible to write the introduction otherwise because the papers must be "self-contained." The structure of the introduction follows that of the sequence of the five papers in the dissertation. Subsection 1.1 sets up the research agenda for papers 1, 2, and 3, and subsections 1.2 and 1.3 outline the research agendas for papers 4 and 5, respectively. Chapter 2 includes a Danish summary of the dissertation whereas Chapter 3 provides comprehensive English summaries of the papers. Chapter 4 presents the data and provides an in-depth discussion of the items and scales that I use in this work. In chapter 5, I present the paradigmatic foundations of the dissertation.

1.1 The roles of finance functions

So far, standard measurements of the roles of finance functions have not been introduced into management accounting research (Mahlendorf, 2014). Furthermore,

¹ Management control is defined by Anthony (1965, p. 17) as "the process by which managers ensure that resources are obtained and used effectively and efficiently in the accomplishment of the organization's objectives." In this dissertation, "management control" encompasses management control mechanisms (Kennedy & Widener, 2008) and management accounting practices (Fullerton *et al.*, 2013).

to my knowledge, there has not been a literature review examining the status of research on the roles of finance function. The dissertation's first paper reviews the empirical literature on the roles of finance functions; it covers the status of the research, briefly elaborates on research opportunities, and develops a survey instrument intended to measure the roles of finance functions in future studies.

From the literature review, it appears that management accounting research has recognized that the roles of finance functions have shifted from a core focus on scorekeeping and statutory duties to an additional emphasis on engagement in firm operations and strategy (Sorenson, 2009). Yet, scorekeeping and statutory roles remain important (Chang *et al.* 2014; Mouritsen, 1996), which implies that the set of roles is larger compared with what it was in the 1980s (Big Eight White Paper, 1989). To some extent, there is research agreement on the drivers of the change, such as increased business and market complexity, organizational changes, new management philosophies (Burns & Baldvindsdottir, 2005), and myths about the benefits of change (Järvenpää, 2007). Research has also found that the relative emphasis on the different finance function roles depends on the context (see, e.g., Byrne & Pierce, 2007), but there is consistent evidence of multiple roles in contemporary finance function practice (Bechtoldt *et al.*, 2014). Only a few papers, however, have studied the possible interplay between roles, and even fewer have considered how finance functions create value for firms. Furthermore, the few papers studying the interplay between finance function roles can be divided into two groups—one arguing that the roles are complementary (Chang *et al.*, 2014), and one arguing that the roles are substitutes (Maas & Matejka, 2009). The second paper in the dissertation focuses on this tension. It studies the possible complementarity among finance function roles and sheds light on how finance functions can create value for firms.

In the third paper, I study the roles of finance functions in Lean firms. The management accounting literature investigating this topic finds that finance functions are involved in performance system design (Ezzamel *et al.*, 2008; Kennedy & Widener, 2008). Furthermore, controlling operative performance seems to be transferred to operational personnel (Jazayeri & Hopper, 1999), but finance functions still perform the financial controlling, although to a lesser extent, and primarily serve as a function of the demands from higher hierarchical levels (Tillema & van der Steen, 2015). The few papers studying the roles of finance functions in Lean firms were case studies, and the roles of finance functions were not their primary research objective. I seek to grasp this window of opportunity in the third paper, which mainly focuses on the roles of finance functions in Lean firms.

1.2 Lean and management control mechanisms

There is no doubt that Lean manufacturing is of great importance to firms pursuing world-class performance (Fullerton *et al.*, 2013). Lean manufacturing is defined as an enterprise-wide management system consisting of interdependent, complementary practices (Kennedy & Widener, 2008), and it has been found to affect firms' management control mechanisms (e.g., Netland *et al.*, 2015). It has been recognized that management control mechanisms can either help or hinder the progression of Lean manufacturing (Åhlström & Karlsson, 1996; Fullerton *et al.*, 2014). However, only a few papers have studied the interdependency and complementarity among Lean management control mechanisms, and these are either single-firm studies (Emiliani *et al.*, 2003; Kennedy & Widener, 2008; Kristensen & Israelsen, 2014) or studies utilizing a reductionist method (Fullerton *et al.*, 2013). In the fourth paper, I study complementarity among Lean management control mechanisms from a holistic perspective. Furthermore, I apply

a statistical method that is 1) new to this topic and 2) captures complementary effects to a greater extent than traditional regression analyses.

1.3 Lean, management accounting practices, and time compression diseconomies

In the fifth and last paper of the dissertation, I contribute to an ongoing debate on management accounting practices in Lean firms. The debate began with the book *Relevance Lost* by Johnson and Kaplan (1987) and was further fueled by Johnson (1992) with his follow up, *Relevance Regained*. In these books, the authors claim that traditional management accounting practices are at best irrelevant for Lean firms and at worst counterproductive, causing dysfunctional behavior. Recent academic literature on this topic has shown that Lean firms simplify their management accounting practices, use value stream costing, and rely on nonfinancial performance measurements (Fullerton *et al.*, 2013; Fullerton *et al.*, 2014). However, Fullerton *et al.* (2013; 2014) did not study whether Lean manufacturing firms abandon the traditional management accounting practices. This paper takes a more holistic perspective on Lean manufacturing and management accounting practices; in addition to studying Lean manufacturing–related management accounting practices, it focuses on traditional management accounting practices and studies the behavioral and performance consequences of management accounting practices and Lean manufacturing. However, the paper does so with a little twist. Callen *et al.* (2000) studied the performance differences between early and late adopters of Lean manufacturing, and found early adopters outperformed the late adopters. In their study, however, these authors did not control for the extent to which Lean manufacturing was implemented in the firms. I grasp this opportunity, and the second contribution of the fifth paper is empirical evidence concerning time compression diseconomies (Dierickx & Cool, 1989) in Lean manufacturing firms.

2. Danske resumé

Denne ph.d.-afhandling omhandler økonomifunktionens roller, økonomistyring og Lean. Ph.d.-afhandlingen indeholder fem artikler, og i afsnittet her præsenteres et kort dansk resumé af hver artikel. Læseren kan finde et mere omfattende engelsk resumé i kapitel 3. Det danske resumé følger afhandlingens struktur, hvorfor jeg indleder med resuméerne vedrørende artiklerne 1, 2 og 3 i undersektion 2.1, hvorefter resuméerne vedrørende artiklerne 4 og 5 følger i undersektion 2.2 og undersektion 2.3.

2.1 Økonomifunktionens roller

Artikel 1: The changing roles of finance functions: A review and analysis of empirical management accounting research.

Forfattere: Henrik Nielsen og Thomas Borup Kristensen.

Status: Dele af denne artikel er udgivet som bogkapitel under titlen: ”Økonomifunktionens roller: Ved vi, hvad vi taler om?” i ”Produktion og Styring – Perspektiver på økonomistyringen” (2016), ansvarshavende redaktører: Bukh, Per Nikolaj og Kristensen, Thomas Borup. Jurist og Økonomforbundets forlag, Danmark.

Artiklens rolle i afhandlingen: Artiklen indeholder et struktureret litteratur review af empirisk forskning om økonomifunktionens roller. De primære formål med artiklen er 1) at skabe et spørgeskemainstrument til måling af økonomifunktionens roller, 2) at identificere ideer til fremtidig forskning herunder artikel to og tre i denne afhandling, og 3) at undersøge om økonomifunktionens roller har ændret sig i den empiriske forskning.

Forskningsspørgsmål: Hvad er status på forskningen omkring økonomifunktionens roller? Ændrer økonomifunktionens roller sig, og hvordan opfanger forskningen dette?

Metodisk design: Artiklen bruger the competing values framework (Cameron *et al.*, 2014) til at studere rollernes udvikling i empirisk forskning og til at udvikle et spørgeskemainstrument, der skal bruges til at måle økonomifunktionens roller i artiklerne 2 og 3. Dertil bruger vi i artiklen Shields' (1997) framework til at analysere forskningens nuværende status. Artiklen anvender ligeledes korrelationsanalyse for at undersøge, om antallet af økonomifunktionens roller øges med udgivelsesårene for artiklerne.

Data: 32 publicerede empiriske artikler, et working-paper og en conferenceartikel.

Resultater: Når vi analyserer litteraturen, finder vi, at antallet af roller inkluderet i hver artikel korrelerer positivt med udgivelsesårene på artiklerne. Vi finder også, at det er den traditionelle økonomifunktionsrolle med fokus controlling, der har fået størst opmærksomhed i forskningen. På linje med Mahlendorf (2014) finder vi, at der mangler et standardspørgeskemainstrument til måling af økonomifunktionens roller. Vi udnytter denne mulighed og udvikler et instrument, der er bygget på the competing values framework. De fleste udgivelser om økonomifunktionens roller har været baseret på kvalitativ forskning, hvor institutionel teori er den mest anvendte metode teori, og hvor produktionsvirksomheder er det mest populære empiriske miljø. En overvejende del af artiklerne undersøger, hvilke faktorer der påvirker økonomifunktionens roller. Det gælder eksempelvis Granlund og Lukka (1998), der undersøger, hvordan den finske kultur påvirker økonomifunktionens roller, eller Burns og Baldvindsdottir (2005), der undersøger, hvordan en organisatorisk forandring i en case-virksomhed

påvirker økonomifunktionens roller. Kun få artikler, herunder Byrne og Peirce (2007), undersøger relationerne mellem økonomifunktionens roller, og hvilke konsekvenser rollerne har.

Artikel 2: The relations between finance function roles, behavioral differentiation, and performance.

Forfattere: Henrik Nielsen og Thomas Borup Kristensen.

Status: Denne artikel planlægges indsendt til European Accounting Review.

Artiklens rolle i afhandlingen: Artiklen bygger på to forskningsmuligheder, der blev identificeret i artikel 1. Den første vedfører sammenspillet mellem forskellige økonomifunktionsroller. Den nuværende forskning vedrørende dette emne kan deles op i to lejre. Den ene argumenterer for, at der er komplementaritet mellem forskellige økonomifunktionsroller (Chang *et al.*, 2014), mens den anden argumenterer at de forskellige roller substituerer hinanden (Maas & Matejka, 2009). Den anden forskningsmulighed er, at der mangler forskning, der undersøger, hvordan økonomifunktionen skaber eller destruerer værdi for virksomheden (Hartmann & Maas, 2011).

Forskningsspørgsmål: Er effekten af den simultane brug og komplementariteten mellem multiple økonomifunktions roller stærkere på adfærdsmæssig (behavioral) differentiation end rollernes additive effekt? Er adfærdsmæssig differentiation i sin tur en driver der forbedrer økonomifunktions præstationer og medfører højere afkastningsgrad?

Metodisk design: I artiklen anvender vi både first-order og second-order strukturelle ligningsmodeller til at analysere hypoteserne. Vi bygger på komplementaritetsteori (Ennen & Richter, 2011) og anvender et

paradoksperspektiv (Schad *et al.*, 2016) til at forudsige relationerne mellem de eksogene og endogene variable i artiklen. Vi bruger spørgeskemainstrumentet, som vi har udviklet via the competing values framework i artikel 1, da det opfanger paradokser, som virksomheder opererer under (Cameron *et al.*, 2014).

Data: Artiklen bygger på en kombination af spørgeskema og regnskabsdata. Spørgeskemadata er hovedsageligt indsamlet hos økonomidirektøren i de 408 deltagende virksomheder, men vi bruger også spørgeskemadata fra produktionsdirektøren i 107 af de deltagende virksomheder.

Resultater: I artiklen finder vi, at den simultane brug af og komplementariteten mellem multiple økonomifunktionsroller påvirker adfærdsmæssig differentiation positivt, mens kun én rolle har en additiv relation til adfærdsmæssig differentiation. Herudover finder vi, at adfærdsmæssig differentiation leder til forbedrede præstationer for økonomifunktionen og forbedret afkastningsgrad.

Artikel 3: Lean and management accountants: Survey evidence of the roles of finance functions.

Forfattere: Henrik Nielsen og Thomas Borup Kristensen.

Status: Artiklen er præsenteret på EIASM konferencen om Performance Measurement and Management Control i Nice, september 2017.

Artiklens rolle i afhandlingen: Artiklen bygger på en forskningsmulighed identificeret i artikel 1. I forskningen lader det til, at økonomifunktionens roller er vigtige og udgør understøttende parametre i forbindelse med udnyttelse og forbedring af nuværende kompetencer (exploitation) og i forbindelse med at finde nye forretningsmuligheder (exploration) (se eksempelvis Burns & Baldvindsdottir, 2005). Virksomheder, der fokuserer på at forbedre nuværende kompetencer og

samtidig fokuserer på nye forretningsmuligheder, defineres som ”ambidekstrøse organisationer” (March, 1991). Adler *et al.* (2009) karakteriserer Lean virksomheder som ”ambidextrous organizations”, og i den tredje artikel undersøger vi, hvordan økonomiafdelingen understøtter exploration og exploitation i virksomheder, der indikerer, at de anvender Lean. Vi bruger spørgeskemainstrumentet, som vi har udviklet via the competing values framework i artikel 1, da det opfanger de vigtige understøttende parametre, der gør, at virksomheder både kan ”udvikle” og ”udnytte” (Carmeli & Halevi, 2009). Vi undersøger ligeledes, om Lean principper i produktionen spredt sig til økonomifunktionen i den tredje artikel. En sådan proces kan kaldes for intraorganisatorisk diffusion (Kim & Srivastava, 1997). Slutteligt undersøger vi i artiklen, om økonomifunktionens roller er indbyrdes afhængige, da der i litteraturen om ambidextrous organizations argumenteres for, at ”udnyttelse” skal balanceres med ”udvikling” (Cao *et al.*, 2009).

Forskningsspørgsmål: Hvordan påvirker Lean økonomifunktionen?

Metodisk design: Vi bruger i artiklen en strukturel ligningsmodel til at undersøge direkte og indirekte relationer mellem de eksogene og endogene variable. Vi anvender et ambidexterity perspektiv og intraorganisatorisk diffusionsteori til at teste artiklens hypoteser.

Data: Artiklen bygger på en kombination af spørgeskema og regnskabsdata. Spørgeskemadata er hovedsageligt indsamlet fra økonomidirektøren i de 408 deltagende virksomheder, men vi bruger også spørgeskemadata fra produktionsdirektøren i 107 af de deltagende virksomheder.

Resultater: I artiklen finder vi, at Lean er positivt relateret til to roller, der understøtter ”udvikling” og to roller, der understøtter ”udnyttelse”. Vi finder

ligeledes, at Lean principper fra virksomhedens operationelle områder spredt sig til økonomifunktionen, og at økonomifunktionens roller er indbyrdes afhængige.

2.2 Lean og management control mechanisms

Artikel 4: The performance effects of complementary management control mechanisms.

Forfattere: Henrik Nielsen, Thomas Borup Kristensen, Lawrence P. Grasso.

Status: Denne artikel er accepteret til udgivelse i International Journal of Operations and Production Management.

Artiklens rolle i afhandlingen: I afhandlingens fjerde artikel flytter vi fokus fra økonomifunktionen og undersøger komplementaritet mellem de ledelsesmæssige styringsmekanismer (management control mechanisms) i Lean produktionsvirksomheder og effekten på præstation (performance). Tidligere forskning på området, eksempelvis Fullerton *et al.* (2013), har anvendt en reduktionistisk metode til undersøgelse af komplementaritet mellem de ledelsesmæssige styringsmekanismer i Lean. Vi anvender holistisk metode, og udvider Kennedy og Wideners (2008) framework, da vi i modsætning til dem skelner mellem socio-visuelle styringsmekanismer socio-kulturelle styringsmekanismer samt mellem finansielle og ikke-finansielle styringsmekanismer.

Forskningsspørgsmål: Er Lean relaterede ledelsesmæssige styringsmekanismer komplementære?

Metodisk design: I artiklen anvender vi både first-order og second-order strukturelle ligningsmodeller til at analysere hypoteserne. Vi anvender komplementaritetsteori

(Ennen & Richter, 2011) til at forudsige relationerne mellem Leans ledelsesmæssige styringsmekanismer og virksomhedspræstation.

Data: Spørgeskemadata fra 368 amerikanske produktionsvirksomheder.

Resultater: Vi finder, at komplementariteten mellem alle Leans ledelsesmæssige styringsmekanismer giver en større præstationseffekt end de isolerede additive relationer. Det er faktisk alene adfærdsmæssige styringsmekanismer og socio-kulturelle styringsmekanismer, der er additivt relateret til performance.

2.3 Lean, økonomistyringsmodeller og time compression diseconomies

Artikel 5: The relations between Lean manufacturing, lean thinking, management accounting and firm performance – it is about time.

Status: En tidligere version af denne artikel er præsenteret på EIASM manufacturing accounting conference i Lissabon 2016 under titlen: The relationships between Lean manufacturing and firm performance: Are they constrained in time? Artiklen har været indsendt til et special issue i Journal of Management Accounting Research. Artiklen blev afvist, men inviteret til genindsendelse til et normalt issue, hvis de foreslåede ændringer foretages. Disse ændringer er under gennemførelse for nuværende.

Artiklens rolle i afhandlingen: Artiklen kigger nærmere på økonomistyringsmodeller i virksomheder, der bruger Lean i produktionen. De ældre økonomistyringssystemer såsom standard costing har været dømt uanvendelige for Lean produktionsvirksomheder, da det argumenteres, at de leder til dysfunktionel adfærd (Johnson, 1992; Maskell *et al.*, 2012). Nyere forskning viser da også, at virksomheder, der anvender Lean i produktionen, anvender Lean relaterede økonomistyringssystemer som value stream costing, men undlader at

undersøge om Lean produktionsvirksomheder faktisk forlader de ældre økonomistyringssystemer (se eksempelvis Fullerton *et al.*, 2013; 2014). Vi tager et mere holistisk perspektiv på økonomistyringssystemer i Lean produktionsvirksomheder, da vi, udover at undersøge forholdet mellem Lean i produktionen og Lean relaterede økonomistyringssystemer, også undersøger forholdet mellem Lean i produktionen og brugen af standardomkostningsvariansanalyser. I artiklen undersøges det ligeledes, hvordan Lean i produktionen og omkostningsmodellerne påvirker Lean thinking, og om Lean i produktionen, omkostningsmodellerne og Lean thinking leder til forbedret operationel præstation. Vi studerer forholdet mellem Lean i produktionen og operationel præstation med et lille twist. Vi undersøger nemlig om tidsomfanget, i hvilken virksomheden har haft Lean, påvirker/moderer forholdet mellem Lean og operationel præstation.

Forskningsspørgsmål: Hvordan påvirker Lean virksomhedens omkostningsmodeller og virksomhedens kultur, og påvirker tidsomfanget i hvilken virksomheden har haft Lean relationen mellem Lean og operationel præstation?

Metodisk design: I artiklen anvender vi en strukturel ligningsmodel til at undersøge direkte og indirekte relationer mellem eksogene og endogene variable. Der foretages ligeledes "subgroup" analyser og time-compression diseconomies (Dierickx & Cool, 1989) i artiklen til at undersøge og forudsige beta koefficientforskelle i relationerne mellem Lean og operationel præstation, Lean og brugen af standardomkostningsvariansanalyser, Leans visuelle styringsmekanismer og operationel præstation samt mellem Lean thinking og operationel præstation.

Data: Spørgeskemadata fra 368 amerikanske produktionsvirksomheder.

Resultater: Vi finder, at Lean produktionsvirksomheder anvender value stream costing og Lean visual controls, altså de Lean relaterede økonomistyringssystemer. Men vi finder også, at Lean produktionsvirksomheder anvender standardomkostningsvariansanalyser. Faktisk finder vi, at relationen mellem Lean i produktionen og standardomkostningsvariansanalyser er positivt influeret/modereret af årrækken i hvilken virksomhederne har anvendt Lean i produktionen. Lean i produktionen, Lean visual controls og Lean thinking er ligeledes positivt relateret til operationel præstation. Men relationerne mellem Lean i produktionen og operationel præstation, samt mellem Lean visual controls og operationel præstation er positivt influeret af tiden/antal år i hvilken virksomhederne har anvendt Lean i produktionen.

3. Extended English Summaries

3.1 Paper I: The changing roles of finance organizations: A review and analysis of empirical management accounting research

Authors: Henrik Nielsen and Thomas Borup Kristensen

Status: Parts of this paper was published as a book chapter entitled: Økonomifunktionens roller: Ved vi, hvad vi taler om?" in "Produktion og Styling – Perspektiver på økonomistyringen" (2016), Eds.: Bukh, Per Nikolaj, Kristensen, Thomas Borup.

The role of the paper in the dissertation: *In the first paper of the dissertation, we perform a literature review of empirical papers on the roles of finance functions. We identify the research agenda with respect to papers two and three, and we develop the measurement instrument pertaining to the roles of finance functions.*

Research Questions: What is the current status of empirical research on the roles of finance functions? Are the roles of finance function changing, and if so, how is this captured by the empirical management accounting literature?

Methodological Design: This study reviews the empirical management accounting literature on the roles of finance functions. It uses the competing values framework (Cameron *et al.*, 2014) in order to separate roles, analyze role development, and develop a survey instrument pertaining to the roles of finance functions. The paper also studies the literature with respect to methods, data analysis techniques, empirical settings, and topics (Shields, 1997). In addition, the papers' findings are briefly described. The paper uses correlation analysis in order to tease out whether the number of finance function roles found in the empirical papers is increasing with publication year.

Data: “Controller and role” and “management accounting/accountant and role” are searched for in the ABI/INFORM and EBSCO host business source premier databases. Thirty-two published empirical papers, one working paper, and one conference paper are reviewed.

Summary and findings: When we analyze the papers via the competing values framework, the roles of finance functions appear to be expanding, as the correlation between publication year and the number of roles included per paper is significant. Studying the emphases of the roles, we find that 55 percent of the identified roles can be related to the internal process quadrant of the competing values framework, which places emphasis on the monitoring of performance, stability, and control. Twenty-three percent of the roles are related to the open systems quadrant, which focuses on growth, innovation, and adaptation to the environment. Fifteen percent of the roles identified in the literature are related to the rational goal quadrant, in which the overarching emphases are on cost reduction, goal setting, and productivity, and eight percent is related to the collaborate quadrant, which stresses internal alignment, autonomy, and cooperation. Moreover, we find that research has been inconsistent with respect to labeling finance function roles, and likewise, the items and scales measuring the roles are very diverse in quantitative papers. We argue that this is detrimental but is also an opportunity for future research. We then go on to develop a survey instrument that is intended for future survey research on finance function roles. It builds on the competing values framework and the findings in the review. We also find that 41 percent of the published papers are qualitative, with interviews being the most popular primary data analysis technique. Thirty-five percent of the papers are quantitative, and this is where structural equation modeling is the most used data analysis technique. Institutional theory is the most frequently applied method theory, followed by contingency theory and

role theory. Regarding empirical settings, most of the research on finance function roles has been conducted in the manufacturing sector, followed by the service sector and health-care sector, respectively. Most papers studied drivers of finance function roles—for example, national culture, enterprise resource planning systems, and organizational changes, *inter alia* (e.g., Burns & Baldvinsdottir, 2005; Goretzki *et al.*, 2013; Granlund & Lukka, 1998). Only a few papers studied the consequences of the roles and the possible relationships between the roles (Byrne & Peirce, 2007; Chang *et al.*, 2014; Maas & Matejka, 2009).

3.2 Paper II: The relationships between finance function roles, behavioral differentiation, and performance

Authors: Henrik Nielsen and Thomas Borup Kristensen

Status: This paper is planned to be submitted to European Accounting Review.

The role of the paper in the dissertation: *The survey instrument pertaining to the roles of finance functions developed via the competing values framework in paper one is used in the second paper of the dissertation because the competing values framework captures the paradoxes that organizations face (Cameron et al., 2014). Paper two is inspired by two research opportunities identified in paper one. The first is the tension between the few papers studying relations between the roles of finance functions: It is argued by Chang et al. (2014) that the roles of finance functions are complementary, whereas Maas and Matejka (2009) argue that they are substitutes. The second is the lack of papers studying the positive or negative consequences of finance function roles—that is, how they create or destroy value for firms (Hartmann & Maas, 2011).*

Research questions: Does the simultaneous use of and complementarity among finance function roles outweigh their isolated, additive effects on behavioral differentiation? In turn, is behavioral differentiation a driver for finance functions that enables them to increase their perceived performance and, furthermore, a driver for increased firm financial performance?

Methodological Design: The paper uses first-order and second-order factors in a structural equation model to analyze the hypotheses. It relies on complementarity theory and a paradoxical perspective in order to predict relations between four finance function roles, the number of full-time equivalents employed by the finance function and behavioral differentiation, and, in turn, the relationships between behavioral differentiation, perceived finance function performance, and return on invested capital.

Data: A combination of questionnaire and financial statement data from 408 different firms in the Danish manufacturing and services sector is used. The questionnaire data are primarily obtained from the CFO. In addition, the paper utilizes data obtained from the COOs of 107 of the 408 responding firms.

Summary and findings: According to a paradoxical perspective, organizations that are able to integrate contradictory elements achieve a greater understanding of causality and organizational wholeness because the contradictory elements inform one another (Chreim, 2005). Furthermore, integrating contradictory elements can foster dialogue and increase organizational focus (Henri, 2006), and studies have found that paradoxical elements are complementary (e.g., Cao *et al.*, 2009). We characterize the four finance function roles as paradoxical elements. We predict and find that the simultaneous use of and complementarity among all four finance function roles is positively related to behavioral differentiation, whereas only one

of four roles is positively related to behavioral differentiation in isolation. To test complementarity, we use a statistical method introduced by Tanriverdi and Venkatram (2005). We compare a second-order model that captures the complementarity among the four finance function roles with a first-order model that accounts for the additive effects of the four roles on behavioral differentiation. In addition, we find that the simultaneous use of and complementarity among all four finance function roles increase the number of full-time equivalents employed in the finance function. Behavioral differentiation is the finance function's ability to understand what role to apply when it is needed. In other words, it is the ability to differentiate between roles—that is, adaptively, flexibly, situation specifically, and appropriately (Hooijberg *et al.*, 1997). As such, when a finance function has a great behavioral differentiation, it understands internal customer demands, performs roles accordingly, and delivers activities and services with high quality. We hypothesize and find that behavioral differentiation is positively related to the perceived performance of the finance function. We argue that finance function workers are more likely to be perceived as effective if they understand what, when, and how a role is expected to be performed. Behavioral differentiation enables the finance function to overcome inconsistencies stemming from demands for their support of other functions in the firm and increases the quality of the finance function's services. We assume that when the quality of finance function services increases, it is likely to be used for managerial decision-making (Weissenberger & Angelkort, 2011). Thus, in the final hypothesis of the paper, we predict and find that behavioral differentiation is positively related to return on invested capital.

Implications for practice: Although the simultaneous use and complementarity of all four finance function roles increase the number of full-time equivalents employed in the finance function, decision makers should not hesitate with respect

to expanding the roles of finance functions in their firms, because the greater behavioral differentiation enabled by all four roles increases return on invested capital.

3.3 Paper III: Lean and management accountants: Survey evidence of the roles of finance functions

Authors: Henrik Nielsen and Thomas Borup Kristensen

Status: The paper was presented at the 9th EIASM Conference on Performance Measurement and Management Control in Nice, September 2017.

The role of the paper in the dissertation: *The third paper is inspired by findings in paper one, in that finance function roles appear to be supporting both exploitation and exploration—that is, ambidexterity (March, 1991). We use the survey instrument pertaining to finance functions developed via the competing values framework in paper one because this framework captures the underlying values of the structures that must be in place in order for organizations to be ambidextrous (Carmeli & Halevi, 2009). Adler et al. (2009) argue that Lean operation firms encompass characteristics of ambidextrous organizations. In the third paper, we go on to study how the roles of finance organizations support firms that indicate that they have implemented Lean with respect to their exploitative and explorative efforts.*

Research question: How does the implementation of a Lean operation affect the finance function?

Methodological Design: The paper uses structural equation modeling and tests both direct and indirect relations between exogenous and endogenous variables. It relies on an ambidexterity perspective (Gibson & Birkinshaw, 2004) and intra-

organizational diffusion theory in order to predict hypotheses between the implementation of a Lean operation and the finance function.

Data: A combination of questionnaire and financial statement data from 408 different firms in the Danish manufacturing and services sector is used. The questionnaire data are primarily obtained from the CFO. In addition, the paper utilizes data obtained from the COOs of 107 of the 408 responding firms.

Summary and findings: Ambidextrous organizations are able to balance exploration and exploitation (March, 1991). We characterize Lean operation firms as contextually ambidextrous, meaning that they encompass organizational structures that enable employees to perform simultaneous exploration and exploitation (Adler *et al.*, 2009). We hypothesize that the implementation of a Lean operation is positively related to the control role and the compete role. These two roles emphasize exploitation. The control role ensures stability and certainty, which are essential for exploitation, whereas the compete role, in turn, focuses on the continuous refinement of current processes, ensuring that the firm exploits current competencies. We also hypothesize that the implementation of a Lean operation is positively related to the adhocracy role and the collaborate role. These two roles ensure exploration. The adhocracy role deals with understanding external customer value and develops new business potential for the firms. These traits are necessary for exploration. The collaborate role ensures that information is tailored to employees who support the fast decision-making and autonomy necessary in Lean operation firms. Likewise, autonomy for employees is essential in ambidextrous firms because it increases their potential to generate innovations. We find that the implementation of a Lean operation is positively related to all four roles. Furthermore, Lean operation firms are tightly coupled (Roberts, 2004), which increases the sharing and dispersion of ideas regarding what works and what does

not in different functional settings (Ross, 1974). As such, we also hypothesize and find that the implementation of a Lean operation is positively related to the use of Lean principles in the finance function. Lean principles in the finance function include a clear understanding of internal customers' needs. Thus, we expect Lean principles in the finance function to be positively related to all four finance function roles, as these are demanded for exploitation and exploration. We find Lean principles in the finance function to be positively related to the compete role, the control role, and the collaborate role. Finally, we argue and hypothesize that the benefits of either role are dependent on the level of the other roles and vice versa. We hypothesize and find that the roles of the finance functions in Lean firms are interdependent.

Implications for practice: It should be acknowledged by decision makers that it is essential to integrate finance functions into the implementation of Lean manufacturing in firms. The finance function supports the refinement of current practices and processes—that is, continuous improvements—and ensures that the firm is on par with the Lean objectives. Furthermore, the finance function changes the management control system so that it fits with the Lean implementation, and it participates in enabling the autonomy needed for employees to make fast decisions. The finance function also provides valuable input with respect to new business opportunities for the firm.

3.4 Paper IV: The performance effects of complementary management control mechanisms

Authors: Henrik Nielsen, Thomas Borup Kristensen and Lawrence P. Grasso.

Status: The paper is forthcoming in International Journal of Operations and Production Management.

The role of the paper in the dissertation: *In the fourth paper, we move on from the focus on the roles of finance functions in Lean firms in the third paper and turn our attention to the management control mechanisms in Lean firms (cf. Kennedy & Widener, 2008). We investigate the complementary effects between Lean management control mechanisms and their effects on firm performance. The method upon which we model complementarity in the fourth paper is the same as the one we use in the second paper.*

Research question: Are Lean management control mechanisms complementary?

Methodological design: This paper uses structural equation modeling to construct a first-order and a second-order model, and relies on complementarity theory (Ennen & Richter, 2011) to predict the relationships between Lean management control mechanisms and firm performance.

Data: The data comprise questionnaires from 368 different American manufacturing facilities.

Summary and findings: The implementation of Lean manufacturing has been found to be associated with companies' management control mechanisms (e.g., Kristensen & Israelsen, 2014; Netland *et al.*, 2015), and it is recognized in the literature that management control mechanisms can either help or hinder Lean manufacturing companies with respect to reaching Lean objectives (Åhlström & Karlsson, 1996; Fullerton *et al.*, 2014). We use the framework developed by Kennedy and Widener (2008) to explain in detail how management control mechanisms are interrelated. We expand Kennedy and Widener's (2008) framework. They distinguished between social control, behavioral control, and output control mechanisms. We increase the granularity of their framework by distinguishing between social cultural and social visual control mechanisms. We

argue that this is important because cultural social control mechanisms are input oriented and are intended to guide behavior ex ante, whereas visual social control mechanisms are intended to guide immediate behavior. We also distinguish between nonfinancial output and financial output control mechanisms. Financial management control mechanisms typically lag behind nonfinancial control mechanisms because many of the nonfinancial management control mechanisms are measurement drivers of future financial results (Johnson, 1992). We hypothesize that the simultaneous use and complementarity of all management control mechanisms has greater performance effects compared with the use of management control mechanisms in isolation. For example, the performance effects of standard operating procedures (a behavioral control mechanism) are greater if they are visualized (a visual social control mechanism) because it is then ensured that all employees are aware of the best currently known standard. Another example is the motivational effects of nonfinancial performance measurement systems. The motivational effects are greater if nonfinancial performance measurement systems are combined with peer pressure (a cultural social control mechanism). In order to test the hypotheses, we utilize the procedure developed by Tanriverdi and Venkatraman (2005). We develop a first-order factor model in which the five management control mechanisms are correlated and additively related to firm performance. We compare the first-order factor model with a second-order factor model in which the first-order factors load on a second-order factor. The second-order factor accounts for the covariance and multilateral interactions among the Lean management control mechanisms. We find that the complementarity effects among all Lean management control mechanisms are greater on firm performance than the additive effects of using the management control mechanisms in isolation. In fact, only the behavioral control and cultural social control mechanisms are significantly related to firm performance in isolation.

Implications for practice: Practitioners should understand that implementing the entire system of Lean management control mechanisms enables greater firm performance than implementing a partial system. However, the implementation of the entire system of Lean management control mechanisms might be relatively easy for competitors to replicate. Thus, practitioners should also understand that the management control mechanisms are complementary which, in turn, might prove to be a competitive advantage (Porter, 1996).

3.5 Paper V: The relationships between Lean manufacturing, Lean thinking, management accounting, and firm performance: It is about time

Authors: Thomas Borup Kristensen, Henrik Nielsen and Lawrence P. Grasso.

Status: A previous version of the paper entitled: “The relationships between Lean manufacturing and firm performance: Are they constrained in time?” was presented at the EIASM Manufacturing Accounting Conference in Lisbon, 2016. The paper was submitted to a special issue on survey research in Journal of Management Accounting Research. The paper was invited to revise and resubmit, but it would be considered as a new submission.

The role of the paper in the dissertation: *In the fifth paper, we also study management control mechanisms in Lean firms, as we did in the fourth paper. More specifically, we turn our attention to how management accounting practices support Lean firms. Moreover, we study the importance of Lean thinking and whether the length of time companies have used Lean manufacturing affects the use of management accounting practices and Lean’s effect on operational performance.*

Research questions: How is Lean manufacturing related to management accounting practices and Lean thinking, and does the length of time companies

have used Lean manufacturing affect the relationships between Lean and management accounting and performance?

Methodological design: The paper uses structural equation modeling and tests both direct and indirect effects between exogenous and endogenous variables. The paper also utilizes subgroup analysis to investigate hypothesized beta coefficient estimate differences. The paper relies on time-compression diseconomies (Dierickx & Cool, 1989) to predict differences in relationships between Lean manufacturing and operational performance, Lean manufacturing and measures of labor and materials efficiency, Lean thinking and operational performance, and Lean visual controls and operational performance.

Data: The data comprise questionnaires from 368 different American manufacturing facilities.

Summary and findings: It is argued in the Lean literature that it is necessary for companies that are implementing Lean manufacturing to simplify their management accounting systems (e.g., Fullerton *et al.*, 2013; Maskell *et al.*, 2012). It includes a reliance on visual control, the use of value stream costing (Fullerton *et al.*, 2014), and the lesser use of traditional management accounting systems with respect to operational decision-making. In fact, Johnson and Kaplan (1987) argue that traditional management accounting systems should be used for financial reporting only. Following these argumentations, we hypothesize and find that Lean manufacturing is positively related to Lean visual controls and value stream costing. However, we also hypothesize that Lean manufacturing is positively related to measures of labor and materials efficiency. We argue that measures of labor and materials efficiency can be used to show variances between actual costs and cost reduction objectives, that managers might be hesitant to substitute measures of

labor and materials efficiency that worked during previous manufacturing regimes, and that measures of labor and materials efficiency show unit-level cost reductions that value stream costing, for example, does not. We find that Lean manufacturing is positively related to measures of labor and materials efficiency. Additionally, we hypothesize and find that measures of labor and materials efficiency, Lean visual controls, and value stream costing are interdependent. We also contend that getting all employees and management involved with and trained in Lean and continuous improvement is essential in Lean manufacturing (Emiliani *et al.*, 2003). We conceptualize this as Lean thinking, and we hypothesize and find that Lean manufacturing is positively related to Lean thinking. Additionally, we hypothesize and find that Lean visual controls and value stream costing are positively related to Lean thinking. We argue that both management accounting practices influence employees' cognition in that they are likely to recognize that these Lean congruent management accounting practices help them develop Lean manufacturing in their facilities (Åhlström & Karlsson, 1996). Lean manufacturing, Lean visual controls, and Lean thinking are also hypothesized and found to be positively related to operational performance. Lean thinking works as a catalyst in that the relationships between Lean manufacturing and operational performance through Lean thinking and between Lean visual controls and operational performance through Lean thinking are significant. The relationships between Lean manufacturing and operational performance and between Lean visual controls and operational performance are significantly moderated by the length of time that companies have used Lean manufacturing. We argue that this is a function of time compression diseconomies (Dierickx & Cool, 1989): The implementation of Lean manufacturing restructures the entire company, and it takes time for employees to learn and fine-tune the new systems and practices.

Implications for practice: Allowing for patience is important for Lean manufacturing companies, as greater performance effects will occur over time without increasing the extent of the Lean manufacturing implementation. Furthermore, practitioners should understand the importance of involving all employees at all hierarchical levels in the Lean implementation because this will not only leverage operational performance additively but will also function as a catalyst for Lean manufacturing and Lean visual controls.

4. Data and questionnaire item scales

This dissertation is based on empirical data from three different sources. These sources were cross-sectional survey data on Danish firms in the manufacturing and services sectors, from which responses were obtained from both the Chief Financial Officers (CFOs) and the Chief Operating Officers (COOs) of the responding firms; financial statement information for the year 2016 from Danish firms obtained from the Danish database of registered companies; and cross-sectional survey data obtained from American manufacturing facilities. We used the Danish data in the second and third papers in the dissertation, and the American data were used in the fourth and fifth papers. The sections here describe the empirical data and questionnaire items used in the papers 2 and 3, and in the papers 4 and 5.

4.1 Papers 2 and 3 - Data

The data sources for the second and third papers were a cross-sectional survey, collected between July 2016 and January 2017, and 2016 financial statement information from Danish firms in the manufacturing and services sectors. We restricted the population to Denmark to control for cultural and institutional differences (Ahrens & Chapman, 2000; Granlund & Lukka, 1998) affecting finance functions. The criteria for inclusion in the target population were that the firms had to employ more than 50 people and the responses had to be obtained from the parent company. Otherwise, sampling was random. The survey was aimed at the CFOs of the sample firms. After three rounds of data collection—two via an email that included a link to an online survey and one via postal mail—we obtained a satisfactory response rate of 29.5 percent. The table below shows the characteristics of the responding firms with respect to sectors.

Table 1: Sample characteristics

Manufacturing <i>n</i> =193		Service <i>n</i> =215	
Iron and rubber	30%	Retail	42%
Machines	30%	Finance	24%
Food	13%	Transportation	14%
Textiles	7%	Utilities	10%
Electronics	6%	Other	7%
Chemicals	4%	Communication	2%
Health care	4%	Property	1%
Furniture	3%		
Media	2%		
Other	1%		
<i>Total</i>	100%		100%

The CFOs provided 66.4 percent of the responses. Other respondents identified themselves as “senior finance manager” (6.6 percent), “controller” (2 percent), CEO (2 percent), and “other” (23 percent). On average, the respondents were 48.5 years of age, had been employed by their current firms for 9 years, and had 5.9 years of tenure in their current positions. The table below shows the respondents’ level of education.

Table 2: Respondents’ level of education

Master’s degree	51.1%
Bachelor’s degree or similar	34.6%
Professional training	5.9%
High school	2.7%
Other	5.5%
Total	100%

As indicated in Table XX, most respondents were educated at a college or university. The majority of the respondents with a college/university degree reported that the degree was in accounting (see Table 3 below).

<i>Table 3: Panel A: Type of master's degree</i>		<i>Panel B: Type of bachelor's degree</i>	
Accounting	46%	Accounting	87.3%
Management accounting	15.6%	Business administration	3.4%
Finance	15.6%	Strategy	3.4%
Strategy	6.2%	Other	5.7%
Economics	3.9%		
Other	14%		
Total	100%		100%

In the second and third papers, we surveyed the CFO with respect to both exogenous and endogenous variables that might foster common method biases (Podsakoff *et al.*, 2003). Furthermore, the roles of finance functions might be performed by one or more than one individual, and the other variables pertaining to the finance function represent unit-level variables (the finance function). Therefore, it was important to address interrater item agreement. In the third paper, we studied finance function roles in Lean firms, and some of the items pertaining to finance function roles used in paper two measured the extent of finance function engagement in operations. Thus, we decided to address parts of the survey to the COOs of the responding firms. We obtained COO responses from 26 percent of the responding firms (107/408). We addressed interrater item agreement using the average deviation index (Burke *et al.*, 1999), and all indexes were acceptable. The responding COOs were 49.5 years old on average, had been employed by the firm for 12.6 years, and had been in their current positions for 6.9 years. We also addressed common method bias by randomly ordering the items measuring

exogenous and endogenous variables in the survey, and we used Hamann’s one-factor tests as well (Podsakoff & Organ, 1986).

4.2 Financial statement information as control and endogenous variables

One problem with a cross-sectional data set is that organizational choices are not uniform across sectors. To address this issue, we controlled for sector in papers two and three. Likewise, to reduce bias stemming from different firm sizes, we controlled for size proxied by the number of employees (Tanriverdi & Venkatraman, 2005) in papers two and three, in which we also controlled for environmental uncertainty proxied for by the standard deviation of sales growth of firms within the same sector during the past three years (Cao *et al.*, 2009). In the second paper, we additionally used debt-to-equity ratio as a control variable, and in the third paper, we used return on invested capital as an endogenous variable. In the table below, we present information on the responding firms with respect to earnings before interests and tax, return on assets, and number of employees.

Table 4: Number of employees, EBIT and ROA (2016)

	Min	Max	Mean	Standard dev.
Number of employees	50	6,833	285	536
Earnings before interests and tax (DKK in thousands)	-628,000	1,541,358	31,789	152,757
Return on assets	-41%	58%	7.8%	12.4%

4.3 Papers 2 and 3- Items and scales

Choosing the number of response categories was a daunting task, as there are opposing theoretical perspectives in this regard. Cox (1980) describes two: the theory of information and the absolute judgement paradigm. The theory of information predicts that the more scale points added, the more information can be obtained. Contrastingly, the absolute judgment paradigm predicts that only limited

benefits are obtained from increasing the number of scale points. Furthermore, should scale points be fully labeled, or should only the end points of the scale be labeled? (Dillman *et al.*, 2009). Eustler and Lang (2015) addressed both the number of scale points and the labeling of scale points using two experiments on accounting business students. They found that variance is maximized at seven scale points; additional scale points do not increase variance, and fewer scale points reduce variance. Furthermore, labeling all scale points also increases variance *and* reduces extreme response and central tendency bias. Thus, we chose a labeled seven-point Likert scale for all questionnaire items in the second and third papers.

The roles of finance functions: The development of items that measure the roles of finance functions requires special attention here because they represent a substantial part of papers 2 and 3 and because we developed several items ourselves. The literature review (paper one) provided the foundation for developing the measurement instrument. We drew on items used in prior survey studies and descriptions of roles in prior case studies, and developed several items ourselves. The items covered the four quadrants in the competing values framework. Furthermore, we relied on functional role theory, which “focuses on the characteristic behaviors of persons who occupy social positions within a stable social system” (Biddle, 1986, p. 70).² A social position can be occupied by several actors and is typically designated by a label such as a teacher, physician, or a management accountant. These social positions *act* in different ways. For example, a teacher grades and lecture students, whereas a physician writes prescriptions. Thus, each social position exhibits a characteristic role (Biddle, 1979).

² In the management accounting literature, functional role theory has been applied, for example, by Maas and Matejka (2009), who studied role conflict and ambiguity with respect to business unit controllers’ dual responsibilities.

We used a frequency scale ranging from 1: never to 7: almost always to capture the extent to which respondents perceived the finance function roles to be part of their work activity (Floyd & Wooldridge, 1992; Floyd & Wooldridge, 1997). Four of five prior survey papers on finance function roles used an importance scale.³ Let us put forth an example of one difference with respect to an importance scale versus a frequency scale. In measuring the importance of a finance function role, we face two obstacles. The first, which is rather obvious, is when respondents indicate that a role is important although it is not important in their organizations. This can be a function of social desirability bias (Podsakoff *et al.*, 2003). If we measure the frequency with which a role is performed, we face social desirability issues as well. The second obstacle to using the importance scale is that respondents might indicate that a role is in fact important, but it is not performed for different reasons. For example, one could imagine that despite respondents indicating that roles are important, they do not perform the roles because of resource constraints, technological constraints, or inertia. An importance scale might then not cover how a role *acts* (cf. functional role theory). A frequency scale ranging from “never” to “always” does not suffer from this problem, as we would expect the respondent to report “never” in such a situation, even though the role is important.

We could also have used an “extent” scale. For example, we could have asked respondents to indicate to what extent the finance function “provides operations with business advice.” One possible problem with such a scale is that the respondent might indicate that the finance function provides operations with business advice to a great extent based on the perceived *impact* of the advice, although the finance function rarely does so. In other words, the respondent might

³ Bechtold *et al.* (2014) used a frequency scale. Chang *et al.* (2014), Hartmann and Mass (2011), Maas and Matejka (2009), and Mouritsen (1996) applied an importance scale. Bechtold *et al.* (2014) applied a frequency scale.

confuse the input with the outcome of a role. A frequency scale does not cause this confusion. It captures the input of activities as a function of the frequency with which they are performed. All three scales described here suffer from another interpretational challenge: Exactly how important is “very important,” how frequent is “occasionally,” and how much is “a great deal”? For example, for some respondents, “occasionally” might imply that the role is performed once a week, whereas it implies once a month for other respondents (Dillman *et al.*, 2009). Instead, Dillman *et al.* (2009) argue that one can apply an actual frequency scale. However, the problem with such a scale is that if respondents are asked to indicate how frequently the finance function performs for example monthly close, they might indicate once a month, but once a month can span 10 days for some finance functions and 3 days for others. Altogether, most questionnaire scales have shared and individual challenges, but we argue that the frequency scale is best suited for capturing the functional form of role theory and is best suited for our research purposes.

In total, the instrument measuring the roles of finance functions consisted of 36 questionnaire items. Through exploratory factor analysis in paper two, four roles were established and each role consisted of five items. We remained loyal to the competing values framework when labeling the roles, and below, we show the roles’ Chronbach’s alpha and composite reliability.

- The adhocracy role: Chronbach’s alpha: .835, composite reliability: .846.
- The compete role: Chronbach’s alpha: .837, composite reliability: .841.
- The control role: Chronbach’s alpha: .703, composite reliability: .739.
- The collaborate role: Chronbach’s alpha: .805, composite reliability: .812.

Through exploratory factor analysis in paper three, four roles were established and each role consisted of four items. This underlines the necessity of using an exploratory factor analysis, although variables have been used and have shown acceptable reliability and validity in prior research. In other words, items from variables used in prior research might load differently when entered in another factor analysis containing different items. See, for example, Grabner and Speckbacher (2016) for a recent paper that does not apply exploratory factor analysis.

- The adhoc role: Chronbach's alpha: .828, composite reliability: .840.
- The compete role: Chronbach's alpha: .720, composite reliability: .734.
- The control role: Chronbach's alpha: .686, composite reliability: .730.
- The collaborate role: Chronbach's alpha: .798, composite reliability: .805.

4.3.1 Paper 2- Items and scales

Behavioral differentiation: Behavioral differentiation was measured by four items with an agreement scale ranging from 1: strongly disagree to 7: strongly agree. We developed the four items, and they captured the definition of behavioral differentiation, which is the ability to apply roles differently—that is, adaptively, flexibly, situation specifically, and appropriately (Hooijberg *et al.*, 1997)—and to apply the right role when it is called for. The variable representing behavioral differentiation had Chronbach's alpha of .849, and composite reliability of .851.⁴

Enterprise resource planning integration: Enterprise resource planning integration was measured by two items with an agreement scale ranging from 1: strongly disagree to 7: strongly agree. The two items captured the quality of the ERP system used by the finance function. The variable representing enterprise

⁴ See paper 2 for all reliability and validity tests.

resource planning integration showed a Chronbach's alpha of .719, and composite reliability of .747.

Finance function perceived performance: Finance function perceived performance was measured by three items. They captured the reputation of the finance function in the organization, finance function success, and how the finance function compared to other finance functions in similar firms. The scale captured the level of satisfaction from 1: very dissatisfied to 7: very satisfied. The variable representing finance function perceived performance had a Chronbach's alpha of .742, and composite reliability of .765.

4.3.2 Paper 3 - Items and scales

Lean operations: All five items were based on Fullerton *et al.*'s (2013) Lean manufacturing. They captured the level of Lean implementation on an agreement scale from 1: strongly disagree to 7: strongly agree. The variable representing Lean operations showed a Chronbach's alpha of .705, and composite reliability of .720⁵

Lean finance: All four items were based on Malmbrandt and Åhlström (2013) and were modified to capture the implementation of Lean principles in the finance function. They were measured on an agreement scale ranging from 1: strongly disagree to 7: strongly agree. The Lean finance variable had a Chronbach's alpha of .732, and composite reliability of .750.

4.4 Papers 4 and 5 - Data

The data source for the fourth and fifth papers was a cross-sectional questionnaire aimed at members registered in the Shingo Prize Organization Database. The Shingo Prize is an award given to companies based on their world-class results and organizational culture. Thus, the sample was not random. However, the Shingo

⁵ See paper 3 for all reliability and validity tests.

Prize Organization Database was chosen because this increased the likelihood of respondents understanding the questionnaire and, consequently, helped alleviate some of the concerns about data collection in survey research (Fullerton *et al.*, 2013). The data for the fourth and fifth papers were collected by Professor Lawrence P. Grasso, Professor Thomas Tyson, Professor Clifford. R. Skousen, and Professor Rosemary Fullerton. The survey was aimed at managers in manufacturing facilities. The responses were received between September and December 2012. In the Shingo Prize Organization Database, a total of 4,537 individuals were represented, several of whom worked at the same manufacturing facility. A total of 512 responses were received, yielding a response rate of 11.2 percent. The responses were averaged if more than one response was received from a facility. The 512 respondents were employed at 368 of 697 different manufacturing facilities, yielding a facility response rate of 52.7 percent. The table below shows the characteristics of the responding facilities with respect to sectors.

Table 5: Sample characteristics: n=368

Automotive	30%
Aerospace	23%
Department of Defense	19%
Health care	29%
Total	100%

Most respondents were responsible for Lean at their facilities and had an average of 11.3 years of management experience. The table below shows respondents' job titles and average years of management experience.⁶

Table 6: Respondents' job titles/responsibility areas and average years of management experience

Job title/responsibility area		Average years of management experience
Lean	27%	9.2
Production	15%	12.1
Engineer	8%	9.9
Plant manager	8%	13.9
CEO/President/Vice-President	7%	13.9
Consultant/Analyst	4%	11.4
Supply chain	4%	10.7
Technician	2%	2.3
Finance/Accounting	1%	10.8
Human resources	1%	6.0
Other	24%	13.2
Total	100%	

Of the responding facilities, most had revenues of more than \$100M and more than 1,000 employees (see the table below).

Table 7: Revenue and size

Revenue		Number of employees	
Over \$100M	53.5%	Over 1,000	43.2%
\$50–100M	13.3%	500–1,000	28.3%
\$5–50M	12.5%	100–500	12%
Under \$5	2.2%	Under 100	2.2%
No response	18.5%	No response	14.4%
Total	100%	Total	100%

⁶ No information with respect to respondents' ages or educational levels was obtained.

As we averaged responses from the facilities from which we received multiple responses, we tested relationships from exogenous variables to endogenous variables using on respondent. We addressed the potential common method bias issue using Hamann's one-factor tests (Podsakoff & Organ, 1986) in papers four and five.

4.4.1 Papers 4 and 5- Questionnaire items and scales

We did not develop the items used in papers four and five. They were developed by Professor Lawrence P. Grasso, Professor Thomas Tyson, Professor Clifford. R. Skousen, and Professor Rosemary Fullerton, and they were mostly based on Fullerton *et al.* (2013; 2014) and Kennedy and Widener (2008). All items were measured on five-point labeled Likert scales.

4.4.2 Paper 4: Items and scales

In paper four, we used the Lean management control mechanisms framework developed by Kennedy and Widener (2008). However, we increased the granularity of their framework as we distinguished between social cultural controls and social visual control, and between financial and nonfinancial control mechanisms.

Social cultural controls: Seven of the eight items were developed, while one item was adapted from Fullerton *et al.*'s (2013) empowerment variable. The items were measured on a scale ranging from 1: strongly disagree to 5: strongly agree with respect to social cultural control mechanisms. The variable representing social cultural controls had a Chronbach's alpha of .904, and composite reliability of .908⁷.

Social visual controls: Four items were adapted from Fullerton *et al.*'s (2013) visual performance measurement information variable. The remaining three items

⁷ See paper 4 for all reliability and validity tests.

were developed in accordance with Kennedy and Widener (2008). All items were developed to measure visualization on an agreement scale ranging from 1: strongly disagree to 5: strongly agree. Social visual controls showed a Chronbach's alpha of .909, and composite reliability of .912.

Behavioral controls: Three of the four items were adapted from Fullerton *et al.*'s (2013) Lean manufacturing strategy variable, and one item was self-developed. The items were measured on an importance scale ranging from 1: not at all to 5: critical with respect to the use of behavioral control mechanisms. Behavioral controls had a Chronbach's alpha of .821, and composite reliability of .826.

Nonfinancial output controls: Three items were developed to measure nonfinancial output controls. The items were measured on an importance scale with respect to the use of nonfinancial performance measures, ranging from 1: not at all to 5: critical. Nonfinancial output controls showed a Chronbach's alpha of .913, and composite reliability of .913.

Financial output controls: Four items were developed to measure financial output controls. The items were measured on an importance scale related to the use of financial performance measures ranging from 1: not at all to 5: critical. Financial output controls had a Chronbach's alpha of .797, and composite reliability of .802.

Firm performance: Seven items were developed in order to measure firm performance. They covered both an accounting and a goal-oriented approach (Kihn, 2005). All the items measured performance improvements caused by Lean on a scale ranging from 1: not at all to 5: a great deal. The variable representing firm performance had a Chronbach's alpha of .912, and composite reliability of .913.

4.4.3 Paper 5- Items and scales

Lean manufacturing: Six of the eight items measuring Lean manufacturing were adapted from Fullerton *et al.*'s (2013) Lean manufacturing strategy variable. The remaining two items were developed in accordance with Liker (2004) and Shah and Ward (2007). The items were measured on an agreement scale with respect to the implementation of Lean elements, ranging from 1: not at all to 5: a great deal. Lean manufacturing showed a Chronbach's alpha of .903, and composite reliability of .904.⁸

Lean thinking: One item was adapted from Fullerton *et al.* (2013), while the remaining items were developed on the basis of Emiliani *et al.* (2003). All the items were measured on an agreement scale ranging from 1: strongly disagree to 5: strongly agree with respect to statements representing the respondent's organizational culture. The variable representing Lean thinking had a Chronbach's alpha of .904, and composite reliability of .905.

Lean visual controls: Six of the seven items measuring Lean visual controls were adapted from Fullerton *et al.* (2013). One item was developed in accordance with Kennedy and Widener (2008). The items were measured on an agreement scale ranging from 1: strongly disagree to 5: strongly agree with respect to statements pertaining to the respondent's management accounting system. Lean visual controls had a Chronbach's alpha of .905, and composite reliability of .907.

Operational performance: Five items were developed to measure operational performance. They captured the operational improvements caused by Lean on a scale from 1: not at all to 5: a great deal. Chronbach's alpha of the operational performance variable was .881, and composite reliability was .885.

⁸ See paper 5 for all reliability and validity tests.

Financial performance: Two items were developed to capture financial performance. They measured financial improvements caused by Lean on a scale from 1: not at all to 5: a great deal. Financial performance had a Chronbach's alpha of .900, and composite reliability of .900.

The remaining two variables were single-item measures. Although the variables in a structural equation model are typically latent multi-item constructs (Kline, 2011), single-item measures are acceptable if they are narrow and unambiguous to the respondents (Sacket & Lawson, 1990).

Value stream costing: One item was developed in order to capture the use of value stream costing on a scale ranging from 1: not at all to 5: a great deal.

Measures of labor and materials efficiency: One item was developed in order to capture the use of measures of labor and materials efficiency on a scale ranging from 1: not at all to 5: a great deal.

5. Method

This section provides the reader insight into the paradigmatic underpinnings of the dissertation. I shall emphasize that the paradigmatic foundation of the dissertation is not my view of the world *per se* or the "right" modus operandi with respect to researching management accounting phenomena. Jerold Zimmerman (2001) is an example of an academic who claims that management accounting research has a "right" paradigmatic foundation. In essence, he is convinced that the paradigm that is best suited to research inquiries regarding management accounting phenomena is based on economics. He states that it is, in fact, from this positivist stance only that management accounting researchers can build a cumulative, rigorous body of knowledge. I am not one of those researchers, and I concur with Lukka and

Mouritsen (2002) that Zimmerman's (2001) conjectures are dangerous because they inevitably lead to the omission of important findings related to management accounting research from the academic conversation. I take a much more pragmatic stance: Different modes of inquiry and bodies of knowledge provide different insights into the aspects of management accounting (Hopwood, 2002). It should, therefore, be of no surprise that I do not appreciate being confined to a paradigmatic "box." The box should at least have an open lid, through which it is indeed possible to draw knowledge from other boxes; hopefully, the research in this dissertation is drawn upon by other researchers who are situated in other boxes as well. Nevertheless, it is useful to elucidate the paradigmatic foundation of this dissertation because a researcher should be fully aware of the assumptions upon which his or her research is based (Burrell & Morgan, 1979), and it is arguably useful for the reader as well.

I begin with a clarification of what I mean by "paradigm." A paradigm is essentially a research perspective; it is the worldview of the researcher, and it determines the way in which the phenomenon of interest is studied (Searcy & Mentzer, 2003). However, the object of study also determines the way in which it is studied, and consequently, the way in which the phenomenon is studied can also change *when* it is studied (see, for example, the Hawthorne studies, Roethlisberger & Dickson, 1939). There are differences of thought within any given paradigm, but each paradigm has its own basic assumptions and is, thus, fundamentally different from other paradigms. I use Burrell and Morgan's (1979) framework, which elegantly distinguishes between four paradigms situated in two dimensions (see Figure XX). I describe the two dimensions and not only the paradigm upon which this dissertation is based. I do so because I argue that it is necessary to understand

the basic assumptions of the different positions of both dimensions in order to get a sense of where one is situated in the framework.

Figure 1: Four paradigms for the analysis of social theory (Burrell & Morgan, 1979)

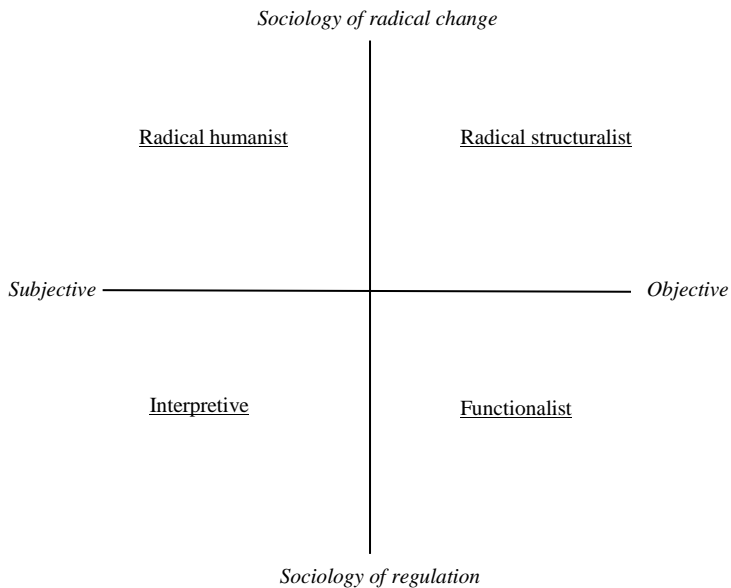

5.1 The horizontal dimension

The horizontal dimension encompasses the principles of scientific method—in other words, how the researcher should study the phenomenon of interest (Chapman, 2012). The horizontal dimension ranges from a subjectivist approach to an objectivist approach to social science. Let us explain these two extremes in more detail. If the researcher believes that management accounting phenomena consist of relatively stable social structures that can be identified as if they are real, the researcher is situated at the objectivist end of the dimension. From an ontological

perspective, the researcher is then a realist, and the social world even exists independently of his or her recognition of it (Burrell & Morgan, 1979). In terms of epistemology, the researcher is positive and seeks to explain *and* predict causal relationships between social structures (Chapman, 2012). The people who occupy the world have almost no possibility of changing it. Thus, the researcher infers from empirical regularities, and only that which is observable is considered valid knowledge (Saudagaran & Diga, 1999). The methodological approach to research in the objective realm is “staying at the porch”—or “arms-length,” as Chapman (2012) puts it—nomothetic by means of hypotheses testing, usually via questionnaires, experiments, and the like (Burrell & Morgan, 1979).

The subjectivist approach is situated on the opposite side of the horizontal dimension. The assumption here is that the social world that is external to the researcher is made up of names, concepts, and labels that are used to structure reality (Burrell & Morgan, 1979). From an ontological perspective, the researcher then occupies a nominalist position (Chapman, 2012). The social reality does not exist in a concrete sense but is a product of the subjective and intersubjective experiences of individuals (Morgan & Smircich, 1980). The researcher uses the names, concepts, and labels to make sense of the external world only. With respect to epistemology, the researcher inquires knowledge as an anti-positivist, meaning that he or she is not interested in causal, stable laws. Rather, he or she focuses on particularism, whereby autonomous individuals create their own realities (Chapman, 2012), and he or she leaves the porch and approaches research ideographically by means of firsthand engagement with the research subject matter (Burrell & Morgan, 1979).

5.2 *The vertical dimension*

The vertical dimension encompasses a distinction between the sociology of radical change and that of regulation, and it leaves researchers to choose which aspects of a phenomenon they should study (Chapman, 2012). If the researcher is interested in providing explanations of society in terms that emphasize its unity and cohesiveness, the researcher relies on the sociology of regulation (Burrell & Morgan, 1979). This sociology seeks to understand why society is held together as an entity instead of falling apart. Its basic assumption about society is that it tends to uphold the status quo (Goles & Hirschheim, 2000) and, furthermore, stresses social order, consensus, solidarity, need satisfaction, and actuality (Burrell & Morgan, 1979). Chapman (2012) operationalizes the sociology of regulation with respect to accounting: “Research work that aims to understand and enhance earnings persistence, or to reduce earnings management, addresses itself to matters of the *status quo*, the existing social order, and what is actually happening in contemporary financial markets” (p. 826).

Conversely, the sociology of radical change tries to find an explanation for structural conflicts, modes of oppression, and structural contradiction, which it sees as characterizing modern society, and it characterizes man as emancipated and constrained, which limits his potential (Goles & Hirschheim, 2000). It is concerned with potentiality and with what is possible rather than moving toward and accepting the status quo (Burrell & Morgan, 1979). With respect to accounting research, the sociology of radical change can enable an understanding of, for example, conflicts between shareholders and employees and can include a study of potential in terms of what has been or what could be (Chapman, 2012).

5.3 To which paradigm does this dissertation belong?

This dissertation has its foundation in the functionalist paradigm. As such, it resides in the paradigm formed by the objectivists and the regulation axes. The functionalist paradigm is concerned with providing rational explanations of the social world, and it focuses on providing explanations of how elements of the social world interact with each other to form an integrated whole (Goles & Hirschheim, 2000). Burrell and Morgan (1979) further elaborate that the functional paradigm emphasizes the importance of understanding order, equilibrium, and stability in society, and its approach to social science assumes that the social world is one of empirical facts and relationships that can be measured using approaches from the natural science (Burrell & Morgan, 1979). As such, the approach of the functionalist paradigm to social science is firmly rooted in positivism.

In papers two and three, we asked respondents to indicate how they perceived the roles of finance functions in their organizations. We measured the roles using reflective variables (Bisbe *et al.*, 2007) and asked the respondents to indicate the frequency with which the finance function performed certain activities. It was then obvious that we see finance function roles as determined by the ways in which they *act*, as perceived by the respondent. As such, we see finance function roles based on functional role theory (Biddle, 1986), as opposed to, for example, symbolic interactionist role theory, whereby roles are, to a great extent, understood as *informal* interactions between actors. In all four empirical papers, we were also inspired by systems theory, in that we studied the interdependency and complementarity between finance function roles (papers two and three), between management control mechanisms (paper four), and between management accounting practices (paper five). Systems theory has its paradigmatic foundation

in the functionalist paradigm (Burrell & Morgan, 1979) and seeks to enable an understanding of groups or entities that work in concert (Abnor & Bjerke, 2009).

Systems theory recognizes that the “whole is more than the sum of its parts.” As such, in order to study systems, one needs to utilize a holistic perspective. We applied a holistic perspective to the finance function roles, in that we expanded the usual two-role taxonomy to four roles in papers two and three. Furthermore, we expanded Kennedy and Widener’s (2008) framework with respect to Lean management control mechanisms in paper four, and we utilized a holistic approach to Lean manufacturing in paper five. When using systems theory, it is necessary to distinguish between open and closed systems (Burrell & Morgan, 1979) and, furthermore, to explicate the “magnifying” level (unit of analysis) of the object of study (Abnor & Bjerke, 2009). An open system is connected and interdependent with other systems in that it “exports and imports” from its environment, and it is affected by the environment during the process. On the contrary, a closed system is isolated from its context (Burrell & Morgan, 1979). In essence, papers two and three are about the roles of finance functions, which, as we measured them, expanded to the entire organization. In paper three, we also specifically studied the relationship between the organizations’ operations and the finance function. In papers four and five, although not represented by roles, we studied how finance function systems represented by management accounting practices (paper five) and management control mechanisms⁹ (paper four) function in Lean firms. Thus, we applied an open systems perspective and focused mainly on the finance function and firms’ operations as the units of analysis. We also, however, recognized the

⁹ Of course, our framework of Lean management control mechanisms does not encompass solely what could be characterized as elements pertaining to the finance function. However, it does, for example, encompass financial and nonfinancial output controls.

firm as an open system, and controlled, for example, for contingency factors that might affect how the firm is organized (Donaldson, 2001).

In as much as the dissertation resides in the functionalist paradigm, it should be underlined that the notion of objectivity should be considered carefully (Chapman, 2012). The empirical papers in the dissertation use “approaches from the natural sciences,” in that they attempt to predict relations via questionnaires and, ultimately, statistical modeling. But these models are not entirely objective, as they are based on relatively subjective judgements with respect to reliability, validity, and fit indices. Although there is, to some extent, agreement regarding what represents acceptable construct reliability and validity (e.g., Fornell & Larcker, 1981; Hair *et al.*, 2014) and model fit (see, e.g., Bollen, 1989; Kline, 2011; Tucker & Lewis, 1973), the judgements of the goodness of these indices, and, more importantly, the judgements of the plausibility of the conclusions, are necessarily up to the reader.

6. References

- Abnor, I. Bjerke, B. (2009). *Methodology for creating business knowledge*. 3rd edition, Sage Publications: London, U.K.
- Adler, P. S., Benner, M., Brunner, J. D., MacDuffie, J. P., Osono, E., Staats, B. R., Takeuchi, H., Tushman, M. L., Winter, S. G. (2009). Perspectives on the productivity dilemma. *Journal of Operations Management*, vol. 27, pp. 99-113.
- Ahrens, T., Chapman, C. S. (2000). Occupational identity of management accountants in Britain and Germany. *European Accounting Review*, Vol. 9 No. 4, pp. 477-498.
- Big eight white paper. (1988). *Perspectives on education: Capabilities for success in the accounting profession*. New York: Arthur Andersen & Co., Arthur Young, Coopers and Lybrand, Deloitte Haskins & Sells, Ernest & Whinney, Peat Marvick Main & Co, Price Waterhouse and Touche Ross
- Anthony, R. N. (1965), *Planning and Control Systems: A Framework for Analysis*, Harvard Business School, Massachusetts.
- Bollen, K. A. (1989), *Structural equation with latent variable*. Wiley: New York, NY.
- Bechtold et al., C., Reimer, M., Schäffer, U. (2014). The Multi-Role Job Profile of Controllers: A Double-Edged Sword. *Working paper presented at the "New Directions in Management Accounting Research"* conference 2014, Brussels, Belgium.

- Biddle, J.T. (1979). *Role theory: Expectations, Identities, and Behaviors*. Academic Press: New York, NY.
- Biddle, J.T. (1986). Recent development in role theory, *Annual Review of Sociology*, Vol. 12, pp. 67-92.
- Bisbe, J., Batista-Foguet, J., Chenhall, R. (2007). Defining management accounting constructs: A methodological note on the risk of conceptual misspecification. *Accounting, Organizations and Society*, Vol. 32, pp. 789-828.
- Burke, M. K., Finkelstein, L. M., Dusig, M. S. (1999). On average deviation indices for estimating interrater agreement. *Organizational Research Methods*. Vol. 2, pp. 49-68.
- Burrell, G., Morgan, G. (1979). *Sociological Paradigms and Organizational Analysis*. Ashgate Publishing, Aldershot: U.K.
- Burns, J., Baldvindsdottir, G. (2005). An institutional perspective of accountants' new roles – the interplay of contradictions and praxis. *European Accounting Review*. Vol. 14, No. 4, pp. 725-757.
- Byrne, S., Pierce, B. (2007). Towards a More Comprehensive Understanding of the Roles of Controllers, *European Accounting Review*, Vol. 16. no. 3, pp. 469-498.
- Callen, J. L., Fader, C., and Krinsky, I. (2000). Just-in-time: A cross-sectional plant analysis. *International Journal of Production Economics* 63: 277–301.
- Cameron, Kim S., Robert E. Quinn., Jeff Degraff & Anjan V. Thakor. (2014). *Competing Values Leadership*. New Horizons in Management, 2nd edition.

- Carmeli, A., Halevi, M. Y. (2009). How top management team behavioral integration and behavioral complexity enable organizational ambidexterity: The moderating role of contextual ambidexterity. *The Leadership Quarterly*, Vol. 20, pp. 207-218.
- Cao, Q., Gedajlovic, E., Zhang, H. (2009). Unpacking organizational ambidexterity: Dimensions, contingencies and synergistic effects. *Organization Science*, vol. 20, No. 4, pp. 781-796.
- Chang, H., Ittner, C. D., Paz, M., T. (2014). The multiple roles of the finance organization: Determinants, effectiveness, and the moderating influence of information system integration. *Journal of Management Accounting Research*, vol. 26. No. 2, pp. 1-32.
- Chapman, C. S. (2012). Framing the Issue of Research Quality in a Context of Research Diversity. *Accounting Horizons*, Vol. 26 No. 4, pp. 821-831.
- Chreim, S. (2005). The continuity-change duality in narrative texts of organizational identity. *Journal of Management Studies*, Vol. 42, no. 3, pp. 567-593
- Cox, E. P. III. (1980). The optimal number of response alternatives for a scale: A review. *Journal of Marketing Research*, Vol. 17 No. 4, pp. 407-422.
- Dillman, D. A., Smyth, J. D., Christian, L. M. (2009). *Internet, Mail, and Mixed-Mode Surveys: The Tailored Design Method*. John Wiley & Sons: New York, NY.
- Dierickx, I., and Cool, K. (1989). Asset stock accumulation and sustainability of competitive advantage. *Management Science* 35 (12): 1504–1511.

- Donaldson, L. (2001). *The contingency theory of organizations*. Sage Publications: Thousands Oaks, CA
- Emiliani, M. L., Stec, D., Grasso, L. (2003). *Better thinking, better results*, The Center for Lean Business Management: LLC, CT.
- Ennen, E., Richter, A. (2010). The whole is more than the sum of its parts – or is it? A review of the empirical literature on complementarities in organizations. *Journal of Management*, Vol. 36 No. 1, pp. 207-233.
- Eustler, J., Lang, B. (2015). Rating scales in accounting research: The impact of scale points and labels. *Behavioral Research in Accounting*, Vol. 27 No. 2, pp. 35-51.
- Floyd, S. W., Wooldridge, B. (1992). Middle management involvement in strategy and its association with strategic type: A research note. *Strategic Management Journal*, vol. 13, pp. 153-167.
- Floyd, S. W., Wooldridge, B. (1997). Middle management's strategic influence and organizational performance. *Journal of Management Studies*, Vol 34 No. 3, pp. 466-485.
- Fornell, C., and Larcker, D. F. 1981. Evaluating structural equation models with unobservable variables and measurement error. *Journal of Marketing Research*, vol, 43, pp. 39–50.
- Fullerton, R. R., Kennedy, F., Widener, S. K. (2013). Management accounting and control practices in a lean manufacturing environment. *Accounting, Organizations and Society*, Vol. 38, pp. 50-71.
- Fullerton, R. R., Kennedy, F., Widener, S. K. (2014). Lean manufacturing and firm performance: The incremental contribution of lean management accounting

- practices. *Journal of Operations Management*, Vol. 32, pp. 414-428.
- Gibson, C. B. Birkinshaw, J. (2004). The antecedents, consequences, and mediation role of organizational ambidexterity. *Academy of Management Journal*, vol. 47. No. 2, pp. 209-226.
- Goles, T., Hirscheim, R. (2000). The paradigm is dead, the paradigm is dead ... long live the paradigm: the legacy of Burrell and Morgan. *Omega*, Vol. 28, pp. 249-268.
- Goretzki, L., Strauss, E., Weber, J. (2013). An institutional perspective on the changes in controllers' professional role, *Management Accounting Research*, vol. 24, pp. 41-63.
- Grabner, I., Speckbacher, G. (2016). The cost of creativity: A control perspective. *Accounting, Organizations and Society*, vol. 48, pp. 31-42.
- Granlund, M., Lukka, L. (1998). Towards increasing business orientation: Finnish controllers in a changing cultural context, *Management Accounting Research*, Vol. 9, pp. 185-211
- Hair, J., Black, W., Babin, B., Anderson, R. (2014). *Multivariate data analysis* (7th ed.). Pearson Education Limited. Edinburgh, England.
- Hartmann, F. G. H., Maas, V. S. (2011). The effects of uncertainty on the roles of controllers and budgets: an exploratory study. *Accounting and Business Research*, Vol. 41 No. 5, pp. 439-458.
- Henri, J-F. (2006). Management control systems and strategy: A resource-based perspective. *Accounting, Organizations and Society*, Vol. 31, No. 529-558.

- Hopwood, A. (2002). If only there were simple solutions, but there aren't': some reflections on Zimmerman's critique of empirical management accounting research. *European Accounting Review*, Vol. 11 No. 4, pp. 777-785.
- Hooijberg, R., Hunt, James. G., Dodge, G. E. (1997). Leadership Complexity and Development of the Leaderplex Model. *Journal of Management*, Vol. 23 No. 3, pp. 375-408
- Jazayeri, M., Hopper, T. (1999). Management accounting within world class manufacturing: a case study. *Management Accounting Research*. Vol. 10, pp. 263-301.
- Johnson, H. T., Kaplan, R. S. (1987). *Relevance Lost: The Rise and Fall of Management Accounting*. Harvard Business School Press: Boston, MA.
- Johnson, H. T. (1992). *Relevance regained: From top-down control to bottom-up empowerment*. The Free Press: New York, NY.
- Järvenpää, J. (2007). Making business-partners: A case study on how management accounting culture was changed, *European Accounting Review*, vol. 16, No. 1, pp. 99-142.
- Kennedy, F. A., Widener, S. K. (2008). A control framework: Insights from evidence on Lean accounting. *Management Accounting Research*, Vol. 19 No. 4, pp. 301-323.
- Kihn, L. A. (2005). Comparing performance measurement approaches in accounting research. *Finnish Journal of Business Economics (LTA)*, Vol. 2, pp. 143-184.
- Kim, N., Srivastava, R. K. (1998). Managing Intraorganizational Diffusion of

- Technological Innovations. *Industrial Marketing Management*. Vol. 27, pp. 229-246.
- Kline, R. B. (2011), *Principles and practice of structural equation modeling*, 3rd edition. New York: The Guildford Press.
- Kristensen, T. B., Israelsen, P. (2014). Performance effects of multiple control forms in a Lean organization: A quantitative case study in a systems fit approach. *Management Accounting Research*, Vol. 25 No. 1, pp. 45-62.
- Liker, J. (2004). *The Toyota Way*. McGraw-Hill: New York, NY.
- Lukka, K., Mouritsen, J. (2002). Homogeneity or heterogeneity of research in management accounting? *European Accounting Review*, Vol. 11 No. 4, pp. 805-811.
- Maas, V. S., Matejka, M. (2009). Balancing the Dual Responsibilities of Business Unit Controllers: Field and Survey Evidence, *The Accounting Review*, Vol. 84, No. 4, pp. 1233-1253.
- Mahlendorf, M. D. (2014). Discussion of the roles of the finance organization: Determinants, effectiveness, and the moderating influence of information system integration, *Journal of Management Accounting Research*, vol. 26, No. 2, pp. 33-42.
- Malmbrandt, M., Åhlström, P. (2013). An instrument for assessing lean service adoption. *International Journal of Operations and Production Management*, vol. 33, no. 9, pp. 1131-1165.
- March, J. G. (1991). Exploration and exploitation in organizational learning. *Organization Science*, vol. 2, pp. 71-86.

- Maskell, B., Baggaley, B., Grasso, L. (2012). *Practical Lean Accounting – A Proven System for Measuring and Managing the Lean Enterprise*, CRC Press, second edition. Boca Raton, Florida.
- Morgan, G., Smircich, L. (1980). The Case for Qualitative Research. *Academy of Management Review*, Vol. 5 No. 4, pp. 491-500.
- Mouritsen, J. (1996). Five aspects of accounting department's work, *Management Accounting Research*, Vol. 7, pp. 283-303.
- Netland, T. H., Schloetzer, J. D., Ferdows, F. (2015). Implementing corporate lean programs: The effect of management control practices. *Journal of Operations Management*, Vol. 36, pp. 90-102.
- Podsakoff, P.M., Organ, D.W. (1986). Self-reports in organizational research: problems and prospects. *Journal of Management*, Vol. 12 No.4, pp. 531-544.
- Podsakoff, P. M., Mackensie, S. B., Lee, J. Y., Podsakoff, N. P. (2003). Common method bias in behavioral research: a critical review of the literature and recommended remedies. *Journal of Applied Psychology*, vol. 88, no. 5, pp. 879-903.
- Roberts, J. (2004). *The modern firm – organizational design for performance and growth*. Oxford University Press. New York: NY.
- Roethlisberger, F. J., Dickson, W. J. (1939). *Management and the Worker*, Harvard University Press, Cambridge: MA.
- Ross, P. F. (1974) Innovation Adoption by Organizations. *Personnel Psychology*, vol. 27, pp. 21-47.
- Sackett, P. R., Lawson, J. R., Jr. (1990). Research strategies and tactics in industrial and organizational psychology. In *Handbook of Industrial and*

Organizational Psychology (2nd ed.), edited by M. D. Dunnette and L. M. Hough, 419–489. Palo Alto CA: Consulting Psychologists Press.

Saudagaran, S. M., Diga, J. G. (1999). Evaluation of the contingency-based approach in comparative international accounting: A case for alternative research paradigms. *Journal of Accounting Literature*, Vol. 18, pp. 57-95.

Schad, J., Lewis, M. W., Raisch, S., Smith, W. (2016). Paradox Research in Management Science: Looking back to move forward. *The Academy of Management Annals*, April, pp. 1-60.

Searcy, D. L., Mentzer, J. T. (2003). A Framework for Conducting and Evaluating Research. *Journal of Accounting Literature*, Vol. 22, pp. 130-167.

Shah, R., Ward, P., T. (2007). Defining and developing measures of lean production. *Journal of Operations Management*, Vol. 25, pp. 785-805.

Shields, M.D. (1997). Research in management accounting by North Americans in the 1990s, *Journal of Management Accounting Research*, Vol. 9, pp. 3-61.

Sorensen, J. (2009). Management Accountants in the United States: Practitioner and Academic Views of Recent Developments. *Handbook of Management Accounting Research*, vol. 3. Chapman, C. S., Hopwood, A. G., Shields, M. D (Eds). Elsevier: U.K.

Tanriverdi, H., Venkatraman, N. (2005). Knowledge relatedness and the performance of multibusiness firms. *Strategic Management Journal*, Vol. 26 No. 2, pp. 97-119.

Tillema, S., Steen, M. V. D. (2015) Co-existing concepts of management control – the containment of tensions due to the implementation of lean production. *Management Accounting Research*, vol. 27, pp. 67-83.

- Tucker, L. R., Lewis, C. (1973). A reliability coefficient for maximum likelihood factor analysis. *Psychometrika*, Vol. 38, pp. 1-10.
- Weissenberger, B. E., Angelkort, H. (2011). Integration of financial management accounting systems: The mediating influence of a consistent financial language on controllership effectiveness. *Management Accounting Research*, vol. 22, pp. 160-180.
- Zimmerman, J. L. (2001). Conjectures regarding empirical managerial accounting research. *Journal of Accounting and Economics*, Vol. 32, pp 411-427.
- Åhlström, P., Karlsson, C. (1996). Change towards Lean production: The role of the management accounting system. *International Journal of Operations & Production Management*, Vol. 16 No. 11, pp. 42-56.

7. Paper 1: The changing roles of Finance Organizations – A review and analysis of empirical management accounting research

Henrik Nielsen^a and Thomas Borup Kristensen^a

^a*Department of Business and Management, Aalborg University*

Abstract

Purpose: Finance organizations are encouraged to change their roles in firms because of the shifting dynamics in business environments. However, research on this topic has not been reviewed systematically. The purpose of this paper is to review the status of empirical management accounting research on the roles of finance organizations.

Design/methodology/approach: This paper categorizes papers according to their methods, data analysis technique, research settings, and method theory and provides a summary of the results. The labels and descriptions of roles are compared, and the competing values framework is utilized to analyze the development and distribution of the roles.

Findings: Research on finance organizations' roles is characterized by great diversity when it comes to method theory. Research methods are almost equally distributed between qualitative and quantitative methods, and research has primarily been conducted in the manufacturing and in the service industry. The analysis via the competing values framework shows the roles of finance organizations are changing and expanding in research. However, an extensive variety of labels and descriptions of roles are used which make it difficult to establish a sound body of knowledge on this topic.

Originality/value: This paper reviews empirical management accounting research on finance organizations' roles. Based on the review, the paper develops a survey instrument and put forth suggestions for future research.

Keywords: Finance organizations' roles, Survey instrument, The competing values framework, Review

7.1 Introduction

Firms are experiencing increasing complexity when it comes to strategy, organizational interdependencies, competition, and change (Hamel and Breen, 2007). Due to these circumstances, institutional bodies and consultancies recommend that finance organizations¹⁰ expand their roles in firms (see Institute of Chartered Accountants in England and Wales, 2011, for a review) which implies that finance organizations should move beyond their traditional work efforts, such as reporting, control, and compliance (Chang *et al.*, 2014). The call for finance organizations to expand their work efforts is not new. In 1916, Gannt advised the record keeper to give up his privilege of merely being a critic, and Anderson (1944) described that finance organizations should broaden their focus and contribute to management by interpreting reports. A change occurred in the late 1960s when increasingly complex business environments and economic challenges led companies to formally create the chief financial officer (CFO) position (Zorn, 2004). The adaption of the CFO position accelerated drastically by the end of the 1970s which was primarily a function of the regulatory demand for replacement accounting. The CFO and the chief executive officer (CEO) quickly became a dynamic duo, and Zorn (2004) posits that these institutional events are the foundations for the finance organizations' rise to prominence in firms.

But are finance organizations important for operational and strategic decision-making, and are their roles expanding? Descriptive studies show mixed results. Russel *et al.* (1999) reported a survey of members of the American Institute of Certified Public Accountants and the Institute of Management Accountants and documented a transformation from “traditional accounting activities to newer, more

¹⁰ Similar to Chang *et al.* (2014) and Mahlendorf (2014), we use “finance organization” as a term that refers to all employees in the management and financial accounting function.

value-added activities” compared to a similar survey conducted a few years earlier (Siegel *et al.*, 1997). Accenture (2014) reported that almost three-quarters of their survey respondents stated that the CFO’s influence in strategic decision-making had increased within the past two years. IBM (2003) reported that finance organizations devoted 50 percent of their work to transactional activities and only 24 percent to decision support. In a 2010 study, IBM found only a marginal increase in the time finance organizations devoted to performance management activities compared to the 2003 study. Furthermore, only 30 percent of respondents in Ernest & Young’s (2010) survey reported that CFOs played a leading role in formulating strategy. The picture is similar in recent surveys conducted by Oracle and Accenture (2013) and McKinsey & Company (2016). Although they are difficult to compare, these surveys show that some finance organizations have moved further than their traditional work efforts whereas some have not. However, most of the descriptive studies do not report why and why not finance organizations have moved beyond their traditional work. A review of empirical management accounting research can help answer these questions.

Recent management accounting studies have shown that finance organizations perform a broad range of activities.¹¹ For example, Chang *et al.* (2014) found that finance organizations set strategic directions and imperatives, and Hartmann and Maas (2011) found evidence of finance organizations helping managers meet their targets. The same studies also showed that finance organizations continued to perform traditional work. Thus, recent research has found evidence of change, in

¹¹ From a role theory perspective, activities contribute to the definition of organizational roles (Biddle, 1986) that can be affected by the expectations of the role senders (Katz and Kahn, 1978) and how actors performing the focal roles perceive the value that the role senders (and other important actors) attach to specific activities (Montano and Kasprzyk, 2008).

particular compared with the work finance organizations performed before the 1960s.

Notwithstanding the evidence of change in research, the topic is under-researched and faces challenges impeding the development of knowledge (Mahlendorf, 2014). According to Mahlendorf (2014), clear definitions of finance organizations' roles are lacking, and various labels¹² are used. Following these statements, Mahlendorf (2014) calls for analysis and comparison of the labels and descriptions of finance organizations' roles.

This paper reviews empirical management accounting research on finance organizations' roles. Based on the review, it provides four contributions to research on finance organizations' roles. First, it uses Shields' (1997) framework to categorize papers, and provides a summary of the research findings and antecedents in Appendix 1. The paper finds that empirical management accounting research on finance organizations' roles uses a great variety of method theories. Most commonly used is institutional theory, which makes sense given Zorn's (2004) evidence. Contingency theory and role theory are the second and third most frequently used method theories. Research methods were almost evenly distributed between qualitative and quantitative, and several papers used mixed methods. Research on finance organizations' roles has mostly been conducted in the manufacturing sector closely followed by the service sector. Second, this paper responds to Mahlendorf's (2014) call and analyzes the labels and descriptions of finance organizations' roles. The results confirm Mahlendorf's (2014) concern. In sum, 22 labels for 45 roles were encountered, and the descriptions of these roles varied significantly. Third, this paper uses the competing values framework (Quinn,

¹² For example, business partner, business strategist, corporate cop, and bean counter.

1984) to shed light on the distribution and development of finance organizations' roles in empirical management accounting research. It finds that the research mostly acknowledges the roles form a continuum. Furthermore, it finds that the complexity (measured as the number of roles included per paper) of the roles is increasing with publication date. Fourth, although the inconsistent use of labels and descriptions is detrimental for management accounting research, it is also an opportunity. We seek to seize this opportunity and use the competing values framework and the experience gained through the review to create a survey instrument intended to guide and enhance future research. Last, the paper discusses prominent determinants of finance organizations' roles and develops ideas for future research.

The remainder of the paper is structured as follows. Section 2 explains the review method, and section 3 reviews the research using Shields' (1997) work. Section 4 introduces the CVF. Section 5 analyzes the roles' labels and descriptions and investigates the distribution and development via the CVF. Section 6 provides the survey instrument whereas section 7 provides a discussion and ideas for future research. Section 8 concludes the paper, and presents limitations. Appendix 1 in section 9 includes a summary of the papers' findings and topics.

7.2 Method and data collection

“Controller” and “role” and “management accountant/accounting” and “role” were searched in the abstracts of peer-reviewed academic papers on the EBSCO host business source premier database. The search terms were based on Ahrens and Chapman's (2000) clarification that “controller” and “management accountant” are used in German-speaking and English-speaking countries, respectively.¹³ This search resulted in 296 and 231 hits; some were duplications. To ensure

¹³ We included only papers written in English in the review.

comprehensiveness, the same search inquiry was conducted in the ABI/INFORM complete database. The results were 164 and 180 hits for controller role and management accountant/accounting role, respectively. The only criterion was that papers had to be empirical and peer-reviewed. The abstracts of relevant papers were read, which yielded 18 papers suitable for the review. As the number was small, the reference lists of the papers were also examined, and the number of publications increased to 33 out of which one was a working paper. Furthermore, another working paper presented at the New Directions in Management Accounting Research conference in 2014 was also included (Bechtold *et al.*, 2014). In sum, 34 papers were suitable as the foundation for the initial research purposes. The publication information is presented in Table 1, and the frequency distribution of papers since 1980 is shown in Figure 1.

Table 1: Publication information

Journal	Number of papers	%
European Accounting Review	10	29%
Management Accounting Research	7	21%
Accounting, Organizations & Society	3	9%
Journal of Acc. and Org. change	3	9%
The Accounting Review	2	6%
Accounting & Business Research	1	3%
Organizational Dynamics	1	3%
Journal of Management Accounting Research	1	3%
The British Accounting Review	1	3%
Total Quality Management	1	3%
Journal of Applied Accounting Research	1	3%
Journal of Applied Management Accounting Research	1	3%
Working Paper	2	6%
Total	34	100%

Figure 1: Frequency distribution of articles

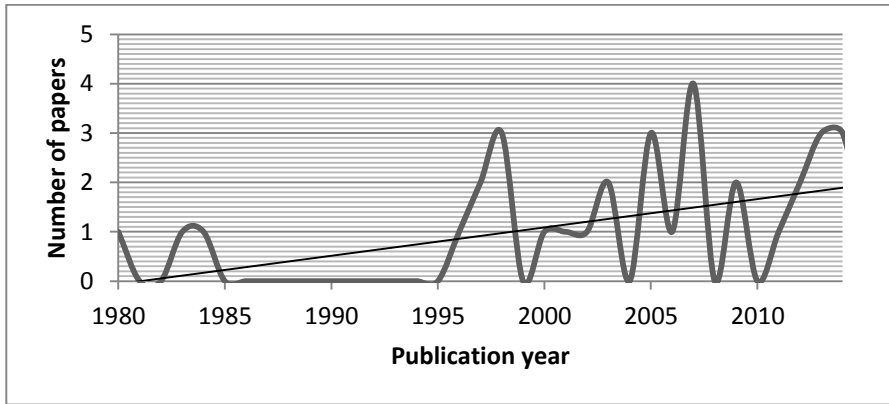

The topic has received the most attention in European journals, and the number of publications per year began to increase in the mid-1990s. To compare role labels and definitions, to analyze roles via the CVF, and to develop a survey instrument for future research, two criteria were added: The papers had to attach a label to a finance organization role (e.g., bean counter), and the papers had to describe the work or activities performed by the role. These criteria reduced the number of papers from 34 to 19.

7.3 *Methods, data analysis techniques, research settings, and topics*

In this section, the initial 34 papers that deal with the roles of finance organizations are examined. We use the same framework as Shields (1997) as the papers' methods, data analysis techniques, settings, and method theory are reported. A summary of the papers' findings and topics is provided in Appendix 1.

7.3.1 *Method*

Forty-one percent of the papers were qualitative, and data was collected through interviews, participation, observations, and archival information. The data sources

ranged from management accountants, finance organization managers, and CFOs to end users of management accounting, such as operational managers, sales directors, general managers, and company owners. Fifty percent of the papers had multiple cases while 36 percent had one case, and 14 percent were longitudinal. Thirty-five percent of the papers were quantitative; data was collected through questionnaires, and the data sources included management accountants, managers in finance organizations, and CFOs. Several papers utilized a dyadic approach, and they were aimed at decentralized and centralized management accountants, management accountants and operational managers, and management accountants in dependent and independent organizations. In 24 percent of the papers, interviews and questionnaires were applied.

Table 2: Method overview

Method	Author	Percentage
<i>Qualitative</i>		
Multiple case study	Ahrens (1997), Ahrens & Chapman (2000), Byrne & Pierce (2007), Chenhall & Langfield-Smit (1998), Friedman & Lyne (1997), Granlund & Malmi (2002), Lambert & Sponem (2012)	50%
Single case study	Caglio (2003), Goretzki et al. (2013), Granlund & Lukka (1998), Lind (2001), Morales & Lambert (2013)	36%
Longitudinal case study	Burns & Baldvindsdottir (2005), Järvenpää (2007)	14%
<i>Mixed methods</i>		
Questionnaire and interviews	Chang et al. (2014), Chapman (1998), Graham et al. (2012), Granlund & Taipaleenmäki (2005), Hopper (1980), Maas & Matejka (2009), Pierce & O'dea (2003), Sathe (1983)	100%
<i>Quantitative</i>		

7.3.2 Data analysis technique

Thirteen of the 14 qualitative papers used interview quotations as the primary data analysis technique, and one used participation. Archival analysis was the most common secondary data analysis technique in eight papers followed by observations in five papers. One paper did not utilize secondary data analysis.

The most common data analysis technique in five quantitative papers was structural equation modeling, whereas multiple regressions, correlation analysis, and Mann-Whitney U tests were utilized in two papers. In one paper, cluster analysis was used. Interviews were used in all mixed-method papers while in some mixed-method papers, multiple regressions, correlation analysis, Mann-Whitney U tests, and descriptive statistics were applied.

7.3.3 Research setting

The most popular research setting was manufacturing companies, followed by the service sector, health care, consumer goods, government/non-profit, marketing, and natural minerals. Several papers had multiple research settings. Six papers did not report a research setting, but further analysis showed the respondents were former students or members of the WHU – Otto Beisheim School of Management controller panel or the companies were members of the Fortune 500.

Table 3: Research settings

Setting	Setting observed in # of papers	Percentage
Manufacturing	16	36%
Service (banking, consulting, telecommunications etc.)	12	27%
Healthcare	5	11%
Consumer goods	3	7%
Government/non-profit	1	2%
Marketing	1	2%
Natural minerals	1	2%
n/a	6	13%
Total	45	100%

7.3.4 Method theory

Most papers utilized institutional theory as the method theory followed by contingency (see Table 4), role, organizational culture, agency, national culture, organizational change, organizational life cycle, practice, social identity, structuration, reasoned action, and upper echelon theory. More than one fourth of the papers did not report a method theory.

Table 4: Method theory distribution

Method theory	Authors	# of papers	%
Institutional	Ahrens & Chapman (2000), Burns & Baldvinsdottir (2005), Goretzki et al. (2013), Granlund & Malmi (2002), Lambert & Sponem (2012), Yazdifar & Tsamenyi (2005)	6	18%
Contingency	Byrne & Pierce (2007), Chapman (1998), Hartmann & Maas (2011), Lind (2001)	4	12%
Role	Bechtold et al. (2014), Hopper (1980), Mass & Matejka (2009).	3	9%
Agency	Indjejikian & Matejka (2006), San Miguel & Govindarajan (1984)	2	6%

Organizational culture	Järvenpää (2007), Morales & Lambert (2013)	2	6%
National culture	Granlund & Lukka (1998)	1	3%
Organizational change	Chenhall & Langfield-Smith (1998)	1	3%
Organizational life-cycle	Granlund & Taipaleenmäki (2005)	1	3%
Practice (theory)	Ahrens (1997)	1	3%
Social identity	Hiller et al. (2014)	1	3%
Structuration	Caglio (2003)	1	3%
Upper echelon	Naranjo-Gil et al. (2009)	1	3%
Theory of reasoned action	Wolf et al. (2015)	1	3%
n/a	Chang et al. (2014), Cooper & Dart (2013), Friedman & Lyne (1997), Graham et al. (2012), Mouritsen (1996), Pierce & O'dea (2003), Sathe (1983), Versteegen et al. (2007), Zoni & Merchant (2007)	9	26%
Total		34	100%

The first part of this paper and Appendix 1 ensured insights into the status of research on finance organizations' roles. Now the paper turns to the second part of the review that responds specifically to Mahlendorf's (2014) call and analyzes the development and distribution of finance organizations' roles in empirical management accounting research. To clarify for the reader, this part of the review includes only 19 of the 34 papers. The decision to remove 15 papers is based on the criteria. The papers had to attach a label and a description to a role. We begin by introducing the CVF.

7.4 The competing values framework

Quinn and Rohrbaugh (1981) and several colleagues developed the CVF. It includes two dimensions, the structure dimension and the focus dimension (Quinn, 1984). The dimensions form a continuum of competing values. In the focus dimension, the external focus is opposed to the internal focus (from left to right on the x-axis in Figure 2). The focus dimension is related to an internal micro-

perspective on employees' well-being and an external macro-perspective on organizational development and competitiveness (Quinn and Rohrbaugh, 1983). Thus, this dimension represents how organizations manage their internal components and simultaneously meet external challenges of competition, adaption, and growth. In the structure dimension, flexibility is in contrast to control (from top to bottom on the y-axis in Figure 1). This dimension is related to a focus on stability versus flexibility (Quinn and Rohrbaugh, 1983). The structure dimension embodies how organizations handle demands for change while maintaining stability.

The dimensions form four quadrants. Moving clockwise, in the top right corner of Figure 2 is the open systems quadrant and then the rational goal quadrant, the internal process quadrant, and the human relations quadrant. The open systems quadrant stresses flexibility, growth, innovation, and creativity. The rational goal quadrant stresses task focus, goal clarity, cost-cutting, efficiency, and performance (Quinn and Rohrbaugh, 1983). The internal process quadrant stresses centralization and control, routines and formalization, stability, continuity and order, and predictable performance outcomes. The human relations quadrant stresses teamwork, participation, empowerment, and a concern for employee ideas (Quinn and Rohrbaugh, 1983). Each quadrant has a diagonal opposite quadrant with contrasting emphases. For example, the open quadrant model stresses flexibility in contrast to the internal process quadrant that, in turn, emphasizes control. In contrast, the juxtaposed quadrants share emphasis. For example, the rational goal and internal process quadrants emphasize control.

Figure 2: The competing values framework

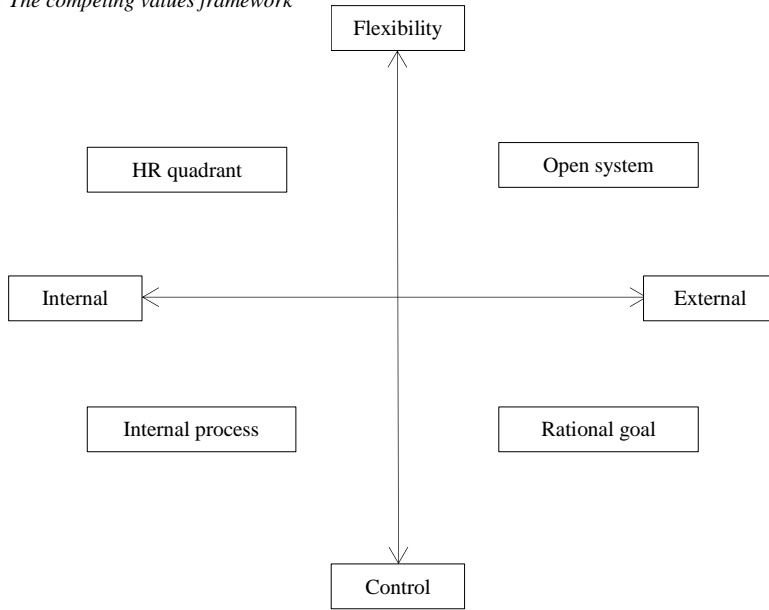

Although certain quadrants and their values are in opposite locations, it does not mean that they are empirically or theoretically mutually exclusive. For example, organizations might be flexible and simultaneously maintain some control (Quinn and Rohrbaugh, 1983). However, as some organizations face different external and internal environments, different organizations might emphasize different quadrants.

7.4.1 The second generation of the competing values framework

Quinn (1984) further developed the CVF with eight roles (two in every quadrant) that were incorporated in a circular pattern based on the two dimensions. The open systems quadrant includes the innovator role and the broker role. The innovator is creative and envisions, encourages, and facilitates change while the broker is politically smart and maintains a unit's external legitimacy through developing, scanning, and maintaining a network of external contacts.

The rational goal quadrant includes the producer role and the director role. The producer is task-oriented and work-focused, emphasizes closure, and motivates the

conclusions of the task while the director sets goals, clarifies roles, and establishes clear expectations. The internal process quadrant encompasses the coordinator role and the monitor role. The coordinator maintains the structure, does the scheduling, coordinates, solves problems, and ensures that standards are met while the monitor collects and distributes information, checks performance, and provides continuity and stability.

Last, the HR quadrant includes the facilitator role and the mentor role. The facilitator encourages the expression of opinions, seeks consensus, and negotiates compromises. The mentor is aware of individual demands, listens actively, is fair, and supports legitimate requests and attempts to facilitate individuals' development. The roles are presented in Figure 3.

Figure 3: The second generation of the competing values framework

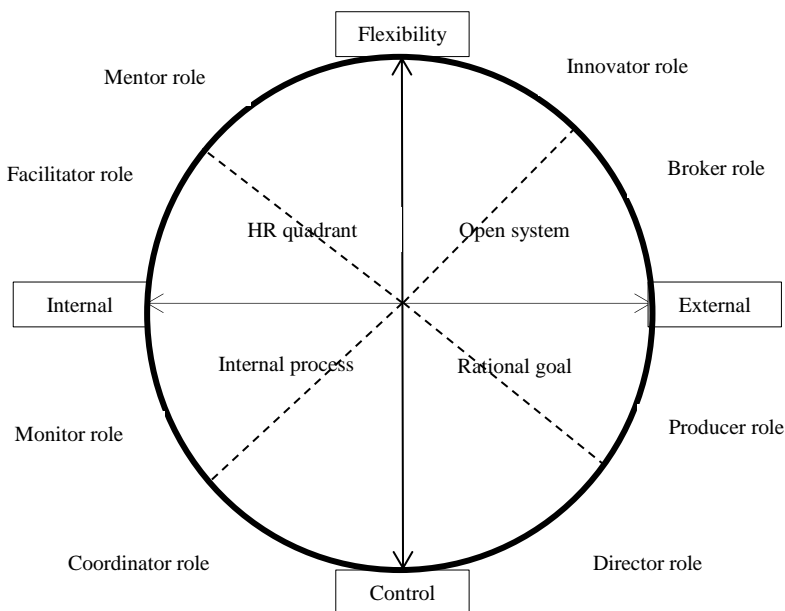

The second generation of the CVF was originally intended to measure leadership roles and effectiveness (Quinn, 1984). However, the focus is not only the finance manager or CFO. This paper uses the second-generation CVF to analyze the activities performed by actors at all hierarchical levels in the finance organization. Some finance personnel (the CFO, managers, controllers, and other personnel) perform multiple roles, and these roles can be incorporated in the CVF. For example, Burns and Baldvinsdottir (2005) found evidence of a finance organization giving strategic advice to operations that is related to the broker role, but the finance organization it also performed variance analysis which is related to the monitor role.

7.4.2 Criteria for incorporating finance organizations' roles in the CVF

The following qualitative criteria are applied for including finance organizations' roles in the CVF: 1) we include a finance organization role if it covers the characteristics of a role in the CVF, 2) if a finance organization role covers the characteristics of multiple roles it is included in multiple roles in the CVF. Most quantitative papers use factor analysis to form roles. The results from the factor analyses are used in the analysis. If factor analysis is not applied in the quantitative papers, the qualitative descriptions of roles are used in the present analysis. Regarding qualitative papers, their findings and qualitative descriptions of roles are used.

7.5 Finance organizations' roles and the CVF

Table 5 includes labels and descriptions (and scales if quantitative) of finance organizations' roles in the 19 papers and their corresponding CVF role. This section begins with a comparison of the roles' labels and descriptions in the literature. In total, 22 labels are attached to 45 roles in the 19 papers. In section 5.4,

the CVF is used to analyze the distribution and development of finance organizations' roles in empirical management accounting research.

Table 5: Finance organizations' roles' labels and descriptions related to CVF roles

Author	Label	Description	Assigned CVF role(s)	Scale
Bechtold et al.	Business Partnering	Develops new strategies for the business and new investment opportunities, finds new ways to meet targets and develops cost saving and revenue plans	Innovator, Broker, Producer	Frequency 1-5
	Corporate Policeman	Focuses on internal controls/procedures, ensures that managers comply with financial reporting requirements, develops reports for higher level managers, assesses whether managers adhere to regulations and that managers do not spend more than strictly necessary	Monitor	Frequency 1-5
	Score-Keeping	Prepares financial reports, collects performance reports, maintains data systems and prepares financial and budgetary plans	Coordinator, Monitor	Frequency 1-5
Burns & Baldvinsdottir	Hybrid: Financial Manager	Emphasized and gave advice to operations concerning strategy	Broker	
	Hybrid: Financial accountant	Helped with and were more engaged in day-to-day operational matters and decisions	Producer	
	Clerical Accountant	Performed tasks such as month end close, cash-flow analysis, budgets and variance analysis	Coordinator, Monitor	
Caglio	Hybrid: Amalgamation of FA and MA	Tasks such as accounts payable, tax duties, treasury management, management accounting, reporting, inventory management and fixed assets	Coordinator, Monitor	
	Hybrid: Business orientation	Extensive understanding of business and operations	Broker	
Chang et al	Prfm. Mgmt. Impt.	Monitoring of performance, aligning internal systems, business improvement, driving cost reduction	Monitor, Facilitator, Mentor, Producer	Importance 1-5
	Strategic Partner	Setting strategic directions and imperatives, presenting performance metrics and information	Broker, Monotor	Agreement 1-5
	RCCR importance	Finance related compliance, internal controls and fiduciary and statutory reports.	Monitor	Importance 1-5
Cooper & Dart	Advisory & Strategic	Focus is on leadership, managing staff and advisory activities, strategic financial planning and management of projects.	Facilitator, Mentor, Producer Broker	Importance 1-4
	Systems	Mangement of projects and staff, management of IT-systems	Producer, Coordinator, Mentor	Importance 1-4

	Emergent Issues		Not applicable	Importance 1-4
	Financial	Prepares statutory reports, analysis and application of accounting standards, corporate governance.	Monitor	Importance 1-4
	Compliance		Monitor, Producer	Importance 1-4
	Business Information	Includes preparation/interpretation/communication of management accounting information, implementation of management accounting systems	Monitor, Producer	Importance 1-4
Friedman & Lyne	Bean Counter	Produces financial information which was of little use in running the business efficiently	Monitor	
Granlund & Lukka	Bean Counter	Has an internal focus, is an information collector, produces accounting reports and fulfills information requirements	Monitor	
	Controller	Has knowledge of the business in which the firm operates, produces accounting numbers relevant for business decisions, stresses that information gets through	Innovator, monitor	
Granlund & Malmi	Business Analyst	Emphasizes value-adding activities related managerial control and decision-making.	Broker, Innovator, Producer, Director	
Goretski et al.	Bean Counter	Focused on reporting, standardization of reports and planning	Monitor, Coordinator	
	Reporter	Development of a reporting system	Monitor, Coordinator	
	Navigator	control several different line-functions, are involved in planning and budgeting	Monitor, Coordinator	
Graham et al.	Fiduciary	Focusses on reporting, forecasting, budgeting and control	Monitor, Coordinator	
	Operational	Focusses on commercial issues and project accounting	Broker, Monitor	
	Strategic		Not applicable	
Hartmann & Maas	Business Partner	Analyzing profitability, reducing costs and increasing earnings and helps managers meet targets. develops/evaluates local business strategy and investment opportunities	Producer, Broker, Innovator	Importance 1-5
	Corporate Policeman	Develops internal controls/procedures, ensures that the	Monitor	Importance 1-5

		business unit comply with financial reporting requirements, develops performance reports, assesses whether the BU adhere to company regulations and ensures that BU managers do not spend more than necessary		
Hopper	Book-keeper	A scorer, implements/administrates financial systems	Monitor	n/a
	Service-aid	Personalizes information and identifies/analyze problems	Coordinator, Monitor	n/a
Järvenpää	Business Partner	Emphasized an increased business and future orientation as well as good communication skills	Innovator, Broker	
Lambert & Sponem	Discrete	Performed reporting and made sure that other line-staff complied with corporate rules	Monitor, Coordinator	
	Safeguard	Emphasized reporting, preparation and monitoring	Monitor, Coordinator	
Lind	Business Partner	Interacted extensively with different line-employees helping them to champion project	Producer	
Mouritsen	Book-keeping	Engages in compliance processes	Monitor	Importance 1-5
	Consulting	Business-orientation, collects and distributes information	Broker, Monitor	Importance 1-5
	Banking	and checks performance Focusses on internal aspects such as cash flow management and currency management	Monitor	Importance 1-5
	Controlling	Performs budgeting and variance analysis	Coordinator, Monitor	Importance 1-5
	Administration	administration of debtors/creditors	Monitor	Importance 1-5
Pierce & O'dea	Business Partner	Knowledge of the business, team-work skills and was an integral part of management teams	Broker. Facilitator Mentor	
Sathe	Involved controller	Described management-service (involvement in business decisions) and financial/internal reporting	Broker, Monitor	n/a
	Independent controller	Described management-service (involvement in business decisions) and Financial/internal reporting	Broker, Monitor	n/a
	Strong controller	Described management-service (involvement in business decisions) and financial/internal reporting	Broker, Monitor	n/a
	Split controller	Described management-service	Broker, Monitor	n/a

7.5.1 Comparison of labels and descriptions in quantitative research

Bechtold *et al.* (2014) used items from Hartmann and Maas (2011). However, Bechtold *et al.* (2014) modified the scale that measured business partner and corporate police roles and applied a frequency scale whereas Hartmann and Maas (2011) applied an importance scale. Only four papers explicitly used the same role labels; corporate policemen and business partners (Bechtold *et al.*, 2014; Hartmann and Maas, 2011) and book-keeping (Hopper, 1980; Mouritsen, 1996). By calculating the similarities between items¹⁴ (a similar word stem of similar items divided by the total word stem of the similar items), this paper found that only 8 percent of the total items shared an identical word stem equal to or more than 90 percent. An additional 8 percent of the items shared a word stem equal to or more than 40 percent but less than 90 percent. Most of these items were part of different constructs. “Compliance” was an item (Chang *et al.*, 2014) but also a construct (Cooper and Dart, 2013), and business partner(ing) was an item (Cooper and Dart, 2013) but also a construct (Bechtold *et al.*, 2014; Hartmann and Mass, 2011).

7.5.2 Comparison of labels and descriptions in qualitative research

Burns and Baldvinsdottir (2005) and Caglio (2003) used the label hybrid or hybridization. Caglio’s (2003) label had two meanings. One regarded the amalgamation of management accounting and financial accounting. The other regarded that controllers needed to gain knowledge of operations and business to

¹⁴ Hopper (1980) was not included in this specific analysis as the paper did not specify constructs and items.

become a business partner. Burns and Baldvinsdottir (2005) characterized two forms of hybrids: a finance analyst and a finance manager. Both interacted heavily with operations. The finance analyst primarily supported operations in day-to-day activities whereas the finance manager supported operations in strategic matters.

Sathe's (1983) "strong controller" shared features with Caglio's (2003) hybridization. The label "business partner" was used by Goretzki *et al.* (2013), Järvenpää (2007), Lind (2001), and Pierce and O'dea (2003). Goretzki *et al.* (2013), Järvenpää (2007), and Pierce and O'dea (2003) shared a common feature of business partners: "knowledge of the business." A similar feature was found in Granlund and Lukka's (1998) definition of a "controller." The "controller" label shared a common feature with Goretzki *et al.*'s (2013) and Lind's (2001) definition of a business partner, and Sathe's (1983) definition of an involved controller, namely, an emphasis on cross-functional interaction. Granlund and Lukka (1998) and Goretzki *et al.* (2013) found that decentralization was an important aspect in becoming "controllers" and "business partners," respectively. The "bean counter" label was used by Friedman and Lyne (1997), Granlund and Lukka (1998) and Goretzki *et al.* (2013) and shared an emphasis on the production and reporting of financial information. The "clerical type" of controller (Burns and Baldvinsdottir, 2005) produced financial information (month end close, cash-flow analysis, budgets, and variance analysis), as did Sathe's (1983) independent controller.

7.5.3 Comparison of labels and descriptions across methods

Seven papers used the label "business partner/analyst." Granlund and Malmi's (2002) "business analyst" and Bechtold *et al.*'s (2014) and Hartmann and Maas' (2011) "business partner" shared "analytical work" and "analyzing product and customer profitability . . . for the business." Goretzki *et al.*'s (2013) "business

partner” supported firm growth, and “supporting firm growth” can be viewed as an umbrella under which several items from Bechtold *et al.*’s (2014) and Hartman and Maas’ (2011) “business partner” would fit. Järvenpää’s (2007) “business partner” provided economic support in strategic matters, and Bechtold *et al.*’s (2014) and Hartmann and Maas’ (2011) “business partner” developed new business strategies.

7.5.4 *The distribution and development of finance organizations’ roles*

In this section, the distribution and development of the roles are analyzed. The analysis is based on the results from examining the literature via the CVF.

Fifty-five percent of the roles can be associated with the internal process quadrant, and 23 percent of the roles in the literature is associated with the open systems quadrant. Roles associated with the remaining quadrants are also found. Fifteen percent is associated with the rational goal quadrant while only 8 percent of the controller/finance department roles are associated with the HR quadrant. Looking at the individual roles in CVF, the monitor role captures most of the roles (39 percent), and the coordinator and broker roles are associated with 16 percent and 17 percent, respectively. The director role is associated with only 2 percent.

Table 6: Role distributions

Facilitator	3%	Broker	17%
Mentor	4%	Innovator	5%
HR total	7%	Open systems total	22%
Coordinator	16%	Producer	13%
Monitor	39%	Director	2%
Internal process total	55%	Rational goal total	15%

Table 6 shows that finance organizations' roles associated with the roles in the HR quadrant are underrepresented. It might be that these roles are beyond the scope of the finance organizations' activities. Further, it might be that finance organizations are not aware of the potential to perform these roles. For example, Russel *et al.* (1999) reported that "human resources and personnel" were the least critical work for finance organizations' employees. Last, it might be that the corresponding departments and management do not believe that finance organizations have the skills to perform roles in the HR quadrant. However, there is a possibility that the lack of roles related to this quadrant represents omitted variables in research.

Several descriptive studies claim that the roles of the finance organization are changing (e.g., Russel *et al.*, 1999; Siegel *et al.*, 1997), and Cooper (1996) argues that because of automation of some finance organization work, employees will be fewer but have different responsibilities. Does the change mean that the roles previously performed are substituted with new ones? Or does it mean that roles are added to existing ones?

Table 7: Correlation between publication year and the number of different roles per paper

	# Different roles
Year	0.596**
N	19

** . Correlation is significant at the 0.01 level (2-tailed).

Table 7 indicates that roles are added as the number of different roles increases over time. If the quadrants are examined in aggregate and the number of roles is summed through slightly more than three decades, then the evolution of the findings and role emphasis can be observed.¹⁵

Figure 4: Changing role emphasis

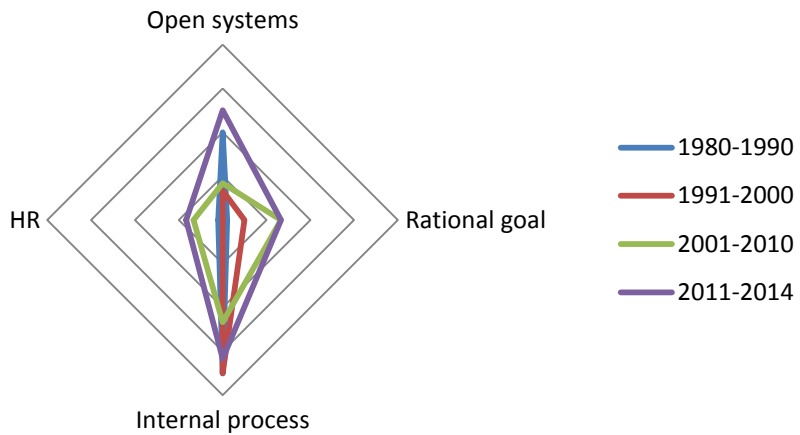

Figure 4 shows that the finance organizations’ roles in the literature have evolved from a continuum (from roles in the open systems quadrant to roles in the internal process quadrant) from 1980 to 1990, to becoming more multifaceted during the following decades.

It is difficult to say whether the increasing number of different roles and the different role emphasis are functions of a real change in roles, a more comprehensive measurement, or increasing attention to an increasing number of roles and a broader role emphasis. Nonetheless, in the American Institute of

¹⁵ We took the number of publications into account by dividing the sum of roles in each quadrant by the number of papers in specific decades.

Certified Public Accountants' (1989) Big Eight white paper, consultancies stated that new tasks and roles were added to management accountants' work, and Boer (2000) found that the number of topics in the management accounting education literature is increasing per publication year. In sum, there is evidence of a role change. However, old roles are not substituted with new roles. The number of roles is increasing, and the role emphasis is multidimensional. It is difficult to predict the future, but perhaps 10 years from now, more findings about finance organizations' roles related to the HR quadrant will emerge.

7.6 Survey instrument

In this section, a survey instrument for future research on finance organizations' roles is proposed. The instrument builds on the experiences that were gained by reviewing the 19 papers, and it is based on the CVF.

It is not postulated that finance organizations should perform all roles in the CVF. Role emphasis can be a function of environmental characteristics, firm characteristics, the characteristics of managers/CFO in the finance organization, etc. (see the findings in Appendix 1), and might even be idiosyncratic. Likewise, extensive role emphasis in one quadrant can reduce the possibility for emphasizing other quadrants equally when resources are scarce. However, we posit that researchers should, *ex ante*, be open to the possibility that finance organizations perform roles that are related to all quadrants in the CVF to reduce the risk of omitted variables and enrich the research with a broader perspective on this topic.

We put forward the following survey instrument to assist research on finance organizations' roles. Quantitative researchers can use the survey instrument as a questionnaire while qualitative researchers can use it as a tool for inspiration for an interview guide. The survey instrument is based on the reviewed 19 papers that

included labels and descriptions of finance organizations' roles, and covers the roles in all quadrants. Authors, labels, and descriptions of specific roles and the associated role in the CVF quadrants are depicted. Items from quantitative literature, as well as findings from qualitative literature are included. As suggested by Mahlendorf (2014), and to reduce the risk of social desirability bias, the survey instrument includes questions covering activities and not roles directly. We suggest a frequency scale to capture the extent to which finance organization employees perceive the roles to be part of their work activity (Floyd and Wooldridge, 1992). Furthermore, we propose a labeled Likert scale from 1 to 7 as it has been shown to reduce measurement error and response bias (Eustler and Lang, 2015). As finance organizations' roles associated with the roles in the HR quadrant are under-represented in the literature three items were developed in the HR quadrant to ensure that the survey instrument is balanced. In addition, one item was developed in the rational goal quadrant. The instrument is shown in figure 5.

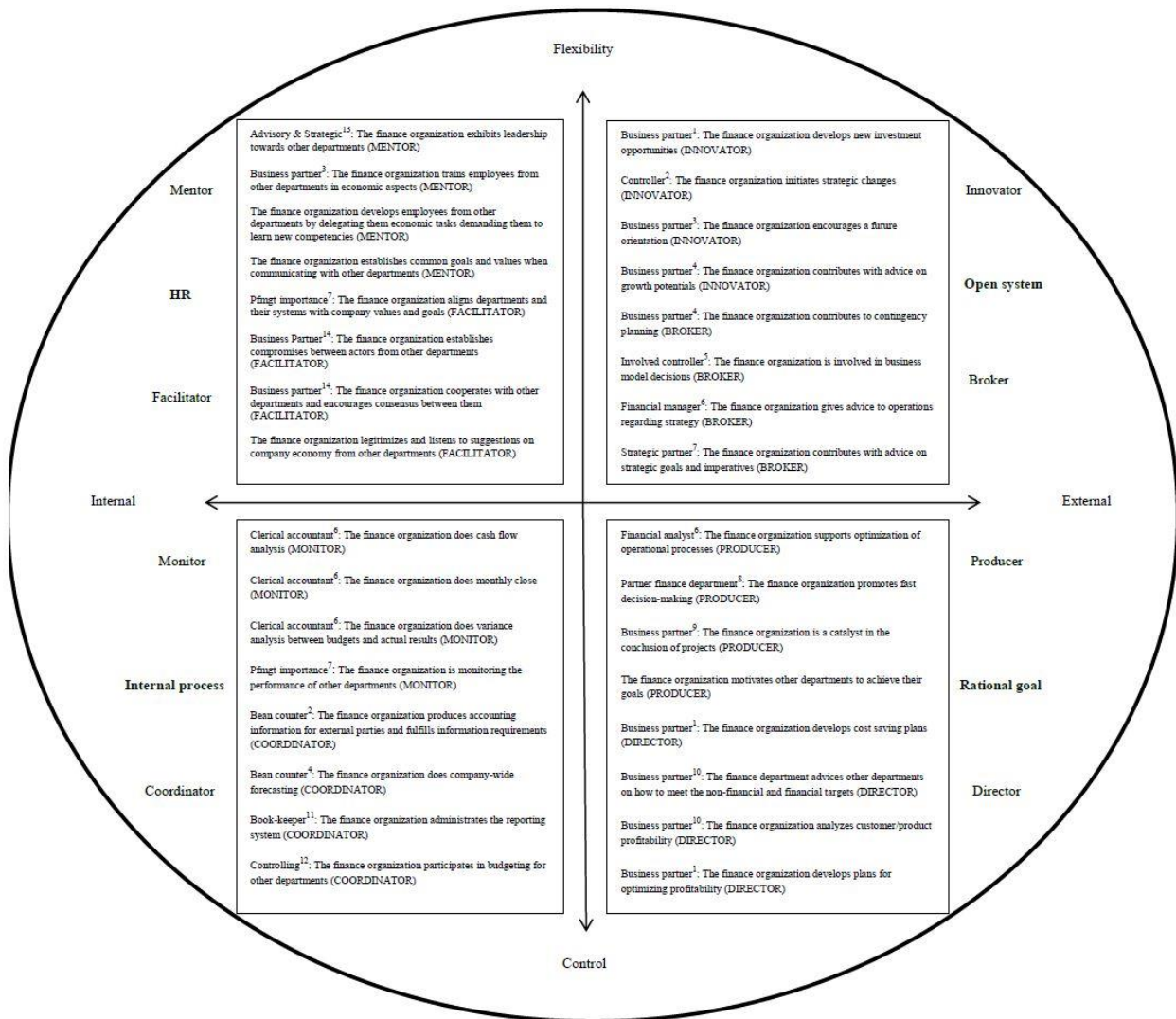

The survey instrument is also helpful for measuring finance organizations' efficiency. For example, if researchers and practitioners investigate optimization effects, they need to consider not only the relative number of full-time employees (FTEs) employed in finance organizations but also the relative role coverage. Using the survey instrument, researchers and practitioners can avoid characterizing finance organizations only by emphasizing the roles in the internal process quadrant as more efficient than finance organizations that cover roles in multiple quadrants and thus, potentially, have more FTEs.

7.7 Discussion and future research

The evidence from the literature shows that finance organization roles are determined by external and internal company factors, factors within the finance organization, and among employees themselves. In this section, we elaborate on prominent findings in the papers and discuss ideas for future research. A summary of the papers' findings is provided in Appendix 1.

Currently, it seems that the implementation of a well-functioning enterprise resource planning systems (ERPS) affects finance organization roles by automatizing some reporting and compliance processes that, in turn, can free up capacity for employees in finance organizations making other business-oriented activities possible (Byrne and Pierce, 2007; Chang *et al.*, 2014; Granlund and Malmi, 2002) and foster interaction between finance organizations and other personnel blurring functional boundaries (Caglio, 2003; Goretzki *et al.*, 2013; Järvenpää, 2007). A possible challenge for finance organizations with well-functioning ERPS might be that it can legitimize companies to lay off employees as the need for their reporting and compliance activities is reduced. Furthermore, as some reporting is taken over by software, it might reduce finance organizations' sense of power from being the favored information provider (Mouritsen, 1996).

CFOs with a business-oriented background and shorter tenure might negate this development by finding new roles for finance organizations as they have been found to be more creative and more experimental with innovative management accounting systems (Naranjo-Gil *et al.*, 2009). A future research possibility is to investigate whether an ERPS implementation fosters a loss of power or, alternatively, increases the performance of reporting and compliance processes, and the performance of business-oriented activities legitimizing expanding roles for the finance organization. If ERPS improves the quality of reporting and internal/external compliance processes, the system might lead to an improved foundation for performing activities related to roles in the open systems quadrant. Furthermore, the implementation of ERPS will foster discussions with other personnel. This might lead to that Finance organization employees achieve a richer understanding of what to report and how to report it, and a richer understanding of how they can support corresponding departments.

Another prominent factor in some of the papers is environmental uncertainty. One would expect that environmental uncertainty demands extensive interaction between the finance organization and other personnel as employees in the finance organization themselves attempt to piece together the meaning of changing information and results, and then communicate these results and information to other personnel (Chapman, 1998). In contrast, when the environment is stable, there might not be a need for extensive interaction between the finance organization and other personnel as information and results are easier to interpret and communicate. However, the evidence for how environmental uncertainty affects finance organization roles is mixed. Byrne and Peirce (2007) found that increased monitoring was necessary because of environmental uncertainty. Hartmann and Maas (2011) did not find a relationship between the business partner

role or the corporate policeman role and environmental uncertainty. Mouritsen (1996) found a negative relationship between the consulting role and environmental uncertainty whereas Chang *et al.* (2014) found positive significant relationships among RCCR importance, performance management importance, strategic partner importance, and environmental uncertainty. A possible explanation for Mouritsen's findings might be that the finance organization, through its consulting competencies and interaction with other personnel, reduces their perception of environmental uncertainty (Mouritsen, 1996). However, he surveyed only finance organization personnel so the explanation remains uncertain. A future research opportunity is to apply either a dyadic questionnaire or to conduct case research. It might be that finance organizations perceive the environment to be uncertain, but by applying appropriate management control systems and by performing appropriate roles, other functional areas will not share this perception.

This paper found that the role emphasis of finance organizations has broadened over time. Furthermore, it found that some finance organizations perform opposing roles in the opposite diagonals of the CVF. For example, Burns and Baldvinsdottir's (2005) roles were incorporated in the open systems quadrant and the internal process quadrant as they ensured that resources were used efficiently by performing variance analysis. However, they also supported operations providing advice on strategic matters. Thus, this finance organization supports the firm with respect to both exploration and exploitation which are the characteristics of ambidextrous organizations (He and Wong, 2004). An interesting path for future research is to shed more light on how and if finance functions enable firms to both explore and exploit.

In as much as the roles of finance functions appear to be broadening, most prior research has still distinguished between two roles (e.g.: Granlund and Lukka, 1998; Hartman and Mass, 2011; Maas and Matejka, 2009). We argue that future research can benefit from being more open to that finance functions can occupy different and an increasing number of roles than the two roles that are often studied. Furthermore, we argue that a broader research perspective on finance function roles increases the likelihood of research providing evidence on how finance functions can create value for firms (cf. Hartmann and Maas, 2011).

Another future research possibility is to investigate complementarities between roles. Sathe (1983) argued that roles in finance organizations could be complementary. However, Hartmann and Maas (2011) did not find evidence of complementarity between the business partner role and the corporate cop role. On the contrary, by correlating residuals from their main regressions, Chang *et al.* (2014) found that all three roles were complementary. As pointed out by Grabner and Moers (2013) and Mahlendorf (2014), this approach assumes that managers make optimal choices when choosing roles and role emphases. The evidence of change in finance organization roles suggests that managers are still experimenting with new roles. Thus, regressing an interaction term of the roles on performance (Mahlendorf, 2014) seem more viable, or alternatively, authors could use the proposed survey instrument to develop a second-order construct using structural equation modeling and test the relations between the individual roles and performance, and the second-order construct and performance (Tanriverdi and Venkatraman, 2005).

None of the papers reviewed investigated possible relationships between firms' financial goal attainment and the roles of the finance organizations. It seems plausible that different degrees of attainment discrepancy between budgets and

goals affect the roles of finance organizations. Lant and Montgomery (1987) investigate how attainment discrepancy affects companies' risk-taking behavior, companies' innovative behavior regarding new customers, markets, and products, and innovative behavior in operational processes. They found that attainment discrepancy is positively related to both types of behaviors. In a finance organization perspective, and if finance organizations have a say, then these processes could be related to roles in the open systems quadrant in the proposed survey instrument. However, when firms face financial distress to a higher extent, tight budgetary controls might be needed (Van der Stede, 2001). The processes associated with tight budget controls can be related to roles in the internal process and the rational goal quadrant in the proposed survey instrument.

Last, albeit academics, consultancies, and practitioners continue to claim that there is a need for role change, there are pitfalls with an increased business orientation and new roles and tasks for finance organizations' personnel. For example, new tasks that are normally perceived positively by finance organizations' employees can be polluted meaning that they are compatible with, for example, a business partner role and even prestigious for the finance organizations' employees. However, the tasks can be perceived as demeaning as the audience repositions them instead enforcing a devalued identity for the finance organizations' employees (Morales and Lambert, 2013). If that is the case, then the new tasks and roles of finance organizations can be used politically which might foster tensions and conflicts between finance organizations and other departments, and between other departments. A positive attitude from other departments thus seems important if the new tasks and roles for finance organizations are to be implemented successfully (Hiller *et al.*, 2014; Wolf *et al.*, 2015). This positive attitude can be achieved by the finance organization legitimizing its new tasks and roles, for

example, by indicating the ability to add value to management (Järvenpää, 2007) and/or to show to other functions that they deserve legitimacy by proving the value of the new tasks and roles (Goretzki *et al.*, 2013). This task, of course, is not easy as other functional areas might feel that the finance organization is moving onto their turf potentially reducing the need for their services. That may be an explanation for the lack of recent large-scale descriptive findings regarding the expanding or changing roles of finance organizations (e.g., Accenture, 2011; Ernst & Young, 2010). Another point to raise in this context is the potential of robotics. In a survey by Deloitte (2015), respondents reported that there was a 50 percent chance that their traditional finance organization work efforts would be overtaken by robotics. This will leverage the need for finance organizations to legitimize their potential to perform other tasks, for example, the HR roles in the proposed survey instrument, as they seem to be unknown territory for finance organizations today. Ernst & Young (2016) argue that the potential for robotics is related not only to the automation of traditional tasks. They argue that robotics can deal with large amounts of data from internal and external sources, such as social media, and robotics can recognize texts and graphical information. Robotics can also contribute with initial business analyses, insights, and conclusions. If the latter is the case, then robotics could leverage finance organizations' contribution to strategic and operational decision-making. However, robotics can possibly take over finance organizations' place in business decisions, making it necessary for finance organizations to legitimize themselves in other playing fields in their firms. How finance organizations are affected by and how they will cope with robotics is an exciting possibility for future research.

7.8 Conclusions and limitations

This paper reviewed the status of empirical management accounting research on finance organizations' roles within the 1980–2015 timeframe. It used Shields' (1997) framework to structure the review, responded to Mahlendorf's (2014) call for analysis and comparison of the labels and descriptions of finance organization roles, and analyzed the distribution and development of finance organizations' roles in research. From a positive perspective, several method theories have been used. Institutional theory has been utilized the most which makes sense given that Zorn (2004) found that institutional factors accelerated the development of the CFO role. The CFO role quickly became the norm in firms, and it initiated the increasing prominence of finance organizations. It also makes sense that contingency theory is the second most frequently applied theory. One would expect that external factors affect the finance organization either directly or indirectly through the firm and that these effects determine whether a specific role emphasis in a given context is appropriate or not. There is almost an equal distribution between quantitative and qualitative papers, and several papers apply mixed research methods. The latter is positive as such a combination can provide substantial learning about management accounting (Ittner and Larcker, 2002). Research on finance organizations' roles has primarily been conducted in the manufacturing industry followed closely by the service industry. These two sectors comprise more than half of the research settings altogether. However, there is still much to explore about how these sectors affect the roles of finance organizations as their effects are rarely elaborated in much detail (see also Messner, 2016). Furthermore, for many other industries, only sparse knowledge of their effects on finance organizations' roles is available. This is a challenge and an opportunity as industry-specific contexts might affect the roles of finance organizations to a great extent albeit Chang *et al.* (2014) found only limited evidence.

Finance organizations have been called to move further than their traditional roles. Descriptive studies have not shown consistent evidence. Analyzing the research on finance organizations' roles via the CVF, this paper has shown that academia has been slightly more consistent as the number of roles is increasing with publication date. For a longer period of time, management control systems have collected and provided information to several different playgrounds in companies, and the results indicate that finance organizations are also beginning to participate in other functions' turfs. However, a point of concern is that especially quantitative papers almost exclusively use different labels and items in questionnaires. This paper concurs with Mahlendorf (2014) in as much as it makes it difficult to establish a sound body of knowledge on this topic. As much as it is a concern, it is also an opportunity for future research. This paper has attempted to assist future research by developing a survey instrument based on the CVF and the literature on finance organizations' roles. The instrument can serve as a questionnaire for quantitative researchers and support qualitative researchers during their engagement with the field. The instrument is also useful for practitioners as they can use it to measure the efficiency of their specific finance organization. Furthermore, this paper has put forward several research ideas intended to catalyze exciting new research endeavors. Altogether, this paper provides a comprehensive insight into the status of empirical management accounting research on finance organizations' roles, and this paper can guide future research.

As with any other type of paper, this review has limitations. A particular limitation is the research inquiries that might neglect papers on this topic. Another limitation is the qualitative criteria for relating finance organizations' roles to the CVF.

7.9 Appendix

Table 1: Summaries and topics

Author	Topic	Findings
Ahrens (1997)	Everyday practice of MAs in Germany and Britain	He found that management accountants in Germany kept a distance from and were detached from everyday operational matters and strategic planning in the companies. Instead, MAs dealt with departments' execution of the companies' strategy not by being involved in planning and execution but more by keeping score of departments' activities using formal frameworks. Economic planning in operational departments and strategic planning were beyond the scope of management accountants as they believed that they did not had the tools to do so. Instead, they focused on getting management's in other departments' ends to meet. Thus, management accountants in German breweries saw themselves as supporters, not proactive interactors. The opposite was found in British breweries. Here, they were proactively involved in planning and executing strategy, e.g., by deciding what product to produce. They were also involved in everyday matters, such as helping salespeople decide which deals to pursue.
Ahrens and Chapman (2000)	Occupational identity of MAs in Germany and Britain	Management accountants in GB aspired to the job because of the high salary and easy education. In Germany, a job as a controller was not only the best alternative. German controllers also figured that to become a member of management, controlling was a great path. German controllers also saw themselves as moderators between senior staff and line management. However, German controllers were more distant in business and operational matters while British management accountants increased their organizational responsibilities by achieving operational and technical skills.
Bechtold <i>et al.</i> (2014)	Multi-role job profile of MAs	They found that multi-role controllers (i.e., controllers with a broad scope of responsibilities) were more likely to face incompatible role expectations. Furthermore, they found that controllers with broad responsibilities also encountered conflicts due to work overload or divergent values or standards. However, they did not find issues of incompatible role expectations adversely affected job satisfaction, and they found that job satisfaction was improved by the increased influence at work caused by the broad scope of responsibilities.
Byrne and Pierce (2007)	Antecedents, characteristics of, and consequences for the roles of MAs	They found several factors affect the roles of finance organizations: ERP systems that reduce repetitive work free up capacity for other tasks, uncertain environments foster a need for monitoring, and regulations increase the need for compliance. In small firms, MAs work horizontally to a higher extent whereas in bigger firms, MAs have a predefined role. Most essential in determining the roles of MAs is the demand for tasks placed on them by the company, the educational background for MAs, and the tenure of the MAs. In addition, operational managers and MAs had a different perspective on how MAs could contribute. Operational managers perceived MAs interaction as hijacking the decision process and fit poorly to operational decision-making while MAs thought the opposite.

Burns Baldvinsdottir (2005)	Role change for MAs	<p>MAs were clerical, performing tasks such as month end close, cash-flow analysis, and budgets. Because of an increased competitive environment, the case company implemented a process method of working, and MAs were financial analysts working closely together with operations and supporting them in day-to-day matters. MAs were also finance managers advising operational managers on strategic matters and risks. Operational personnel performed many of the tasks previously performed by MAs.</p>
Caglio (2003)	ERP MA roles	<p>Implementation of ERP transformed the role of accountants in two ways: The financial accountants' and MAs' roles were amalgamated, and the ERP system blurred functional boundaries as it considered entire work processes. This led to a redefinition of the relationship between workers and accountants and moved the role of accountants toward "hybridization" (i.e., the accountants' responsibilities and competencies were more broadly defined).</p>
Chang <i>et al.</i> (2014)	Determinants of MA roles	<p>Found that the roles of finance organizations were determined by several company and external characteristics. They reported too many to mention here, but the important relationships were the following: Information systems integration was positively associated with the importance of RCCR (internal control/risk management activities), performance management activities, and strategic partner activities. There were national differences in role importance. Sector differences, size, growth, and organizational change also affected the three roles differently. They also identified gaps between the importance of finance organizations' roles and the perceived effectiveness of those roles. Furthermore, they found evidence of complementarity among the finance organizations' roles.</p>
Chapman (1998)	Environmental and MAs' roles uncertainty	<p>In one company, the finance organization played a prominent role in supporting other personnel because of high environmental uncertainty and shifting environments. The finance organization communicated heavily with other personnel about prior, current and future performance, expectations, and planning. In another company affected by environmental uncertainty, this was not the case as communication was substituted with complex software that spread information to other personnel. The finance organization sorted and manipulated the information passed on to other personnel, however. In one company that was not challenged by environmental uncertainty, the finance organization interacted heavily with other personnel in planning and evaluation but not in everyday matters. In the last company, not challenged by environmental uncertainty, the finance organization did not interact with other personnel to a high extent.</p>
Chenhall and Langfield-Smith (1998)	Factors influencing how MA's influenced the development of performance measures	<p>They found five factors affecting how MAs influenced the development of performance measures: 1) A shared belief that the finance organization could play a role in change programs, 2) the level of senior management support for the development of innovative MAs, 3) the presence of a MA master, 4) the level of technical and social skills of MAs, and 5) the hierarchical position of MAs in the companies. In three of five companies, MAs participated in developing performance measures.</p>
Cooper and Dart (2013)	The importance of various MA activities	<p>They found that decentralized accountants ascribed more importance to advisory and strategic and emergent issues than centralized accountants. Furthermore, they found that the relative importance of strategic and advisory and compliance increased. In contrast, the importance of systems activities decreased as the firm size increased.</p>

Friedman and Lyne (1997)	The implementation of ABC and the resulting view of the bean counter role	In six of 11 cases, they found that activity-based techniques required more interaction between MAs and operational managers and improved their mutual relationship. Further, because of the increased interaction, the view of MAs as merely bean counters was fading.
Goretzki <i>et al.</i> (2013)	Changes in the finance organization driven by a newly appointed CFO	The appointment of a new CFO changed the MAs' roles from bean counters to business partners and innovators. The CFO brought with him new ideas about how employees of the finance organization should work, implemented a new ERP system, and decentralized some MAs to other functional areas, such as marketing, manufacturing, and logistics.
Graham <i>et al.</i> (2012)	Exploration of financial controller roles	Found that the traditional role (the fiduciary role and to some extent, the operational role) of financial accountants had not diminished. Instead, the traditional role was supplemented by tasks that are more concerned with the business as a whole. Furthermore, they found that the financial controllers believed that their role should be expanded. They did not investigate the antecedents of management accountants' roles.
Granlund and Lukka (1998)	Investigation of how Finnish culture affects controllers in operations and communication	Finnish culture affected MAs' roles, and a transition among roles was present. MAs' roles transitioned from bean counters to controllers. However, this transition was realized only for MAs who worked in companies undergoing decentralization.
Granlund and Malmi (2002)	ERP implementation and MAs' roles	ERPs automatized daily routing work and freed up capacity enabling MAs to move from bean counters to business analysts in some cases. Most remained bean counters but aspired to be business analysts in the future.
Granlund and Taipaleenmäki (2005)	Investigation of management accounting and control in a new economy firm	They found that the roles of the finance organization become more active and analytical when companies move forward in their life cycles. The roles move from 1) historian and watchdog to 2) roles as advisors, consultants, and change agents and 3) ultimately, business partners. However, preparing financial statements, etc., continued to be important regardless of the current role. Thus, the roles were not substituted; they were expanded.
Hartmann and Maas (2011)	Investigation of the effects of uncertainty on budget use and controller roles	They found that the enabling use of budgets was positively associated with a higher emphasis on controllers' business partner role. Enabling use of budgets was also positively associated with the corporate policeman role. Furthermore, they found that coercive use of budgets was positively associated with a higher emphasis on controllers' corporate policeman role, and they found that task uncertainty was positively associated with the business partner role while environmental uncertainty was not associated with either role. The impact of other business units (how much the focal business unit was affected by other business units) was positively associated with the business partner role while the impact on other business units was not.

Hiller <i>et al.</i> (2014)	Investigation of occupational prestige	MAs'	They found that higher perceived occupational prestige (i.e., how MA's perceived other personnel's attitude toward MA's) led to a higher level of professional and organizational identification and to lower organizational and professional conflict. In addition, perceived occupational prestige indirectly through organizational and professional conflict reduced MAs' turnover intentions. A positive attitude toward MA's in companies thus seems to be important in reducing possible conflicts between the general values of MA's and their company also reducing MAs' intention to find other companies to work for.
Hopper (1980)	Role conflicts of MAs		He found that in general, managers wanted more interaction with accountants. Furthermore, when managers were asked what their accountant's role should be, only two of 12 managers restricted it to the book-keeping role-related tasks.
Indjejikian and Matejka (2006)	How business unit controllers focus affect organizational slack		They found partial evidence of higher organizational slack when business units (represented by controllers) had more knowledge than the corporate headquarters (information asymmetry). Likewise, they found that organizational slack is higher when business unit controllers focus more on providing information for local decision-making rather than for central organizational control. However, at the same time, a local focus by business unit controllers is beneficial for the business unit.
Järvenpää (2007)	Change in MA culture		Because of business change, the case company reorganized and implemented new management accounting systems and ERP. These changes fostered interaction among MAs and other staff, and shifted MAs' focus from short to long term, from historic to future orientation and from pure financial matters to business processes and strategies making management accountants business partners.
Lambert and Sponem (2012)	Investigation of MAs' roles		Found four roles for the finance organization with different logics, activities, positioning, clients, and authority. These roles, in turn, had different positive and negative effects at the organizational and individual levels.
Lind (2001)	Investigation of how a company's world class manufacturing (WCM) affected MAs		The case company implemented WCM. This affected MAs to function more as business partners. They now help champion operations projects; they also emphasize non-financial measures and provide more disaggregate information to line staff.
Maas and Matejka (2009)	Role conflicts and role ambiguity of business units controllers		They studied business unit controllers' dual and conflicting demands. They found that even though business unit controllers were willing to compromise functional duties within "some range," an emphasis on their functional responsibility (responsibility to HQ) was negatively associated with the controllers' ability to support local decision-making and induce role ambiguity and role conflict (because of the simultaneous occurrence of several pressures or unclear job demands). In addition, role conflict and role ambiguity are associated with misreporting. Thus, business unit controllers respond to role conflict and ambiguity by misreporting probably to deal with role stress.

Morales and Lambert (2013)	The perception of MAs' work	<p>They found that business partner-oriented tasks (normally perceived positively) could be viewed as polluted (meaning tasks that are compatible with the business partner role and maybe even prestigious for MAs but have the potential of being perceived as demeaning as the audience repositions those tasks instead enforcing a devalued identity). For example, the creation of business reports intended to influence the organization to make the right decision by one MA (normally perceived positively), but instead, they were used as rigid frameworks upstream and to impose decisions by the vice CFO. They also found that although increasing business orientation avoided unclean work (work not compatible with MAs' work identity), it generated more polluted work.</p>
Mouritsen (1996)	Exploration of finance organizations' roles	<p>Mouritsen found that accounting departments' work is infrequently related to macro-organizational (contingency) factors. However, environmental uncertainty was negatively associated with the consulting role, as were financial firm characteristics. Internationalization was negatively associated with the book-keeping role, while firm size (revenue) was positively related to this role. Internationalization, organization size, and financial firm were positively associated with the banking role while service firm was negatively associated. None of the chosen contingency factors were positively associated with the controller and administration role. Instead, he found that finance organizations' roles are mostly determined by interaction with senior management and line functions (e.g., their demand for finance organizations' work), and he argued that the roles were determined by what finance organizations wanted to do themselves in companies yet ultimately determined by demand.</p>
Naranjo-Gil <i>et al.</i> (2009)	CFO role in management accounting systems' innovation	<p>They found that younger, business-oriented CFOs (measured by their education) with a shorter tenure tend to adopt more innovative management accounting systems than their counterparts. Likewise, they found that companies' tendency to be prospectors interacted positively with business-oriented CFOs and CFO tenure (shorter) in affecting the use of innovative management accounting systems.</p>
Pierce and O'dea (2003)	Comparison of the perceptions of MAs and managers in the same organizations regarding information supplied by the MA function	<p>They identified several differences in the perceptions of managers and MAs. Typically, MAs over-rated the quality of the information they provided to the managers. In addition, there were differences in the perceived use of management accounting techniques by MAs and managers that suggest managers supplement information received from MAs with information from others. Managers generally perceived the information provided by MAs as driven by accounting rules rather than their needs. However, in some instances, MAs were important members in different aspects of operations and business. Managers wanted MAs to act as business partners, e.g., by being in close physical proximity with operational managers fostering business and operations understanding and an understanding of the managers' information needs. However, some MAs were reluctant to pursue this transformation as they feared losing hierarchical control.</p>

San Miguel and Govindarajan (1984)	The use of internal and external compliance auditing, the use of financial audit data, and controller independence	They found that companies used internal and external compliance audits to a higher extent in firms with lower division controller independence compared to firms with higher division controller independence. In addition, they found that companies used financial internal audit data to a higher extent in firms with lower division controller independence than in firms with higher controller independence. Thus, less independence between division controllers and corporate fostered the use of more audits/controls to ensure the independence of the division controller.
Sathe (1983)	Controllers' involvement in management	Found evidence of four controller roles according to their responsibility and the involvement in and contribution to management decision-making,
Verstegen <i>et al.</i> (2007)	An exploratory study to classify controllers by activities	Found that the following triggers were statistically significant in predicting MAs' roles: The greater someone's financial expertise, the more likely he or she is an information adapter; the more someone is a line member, the more likely he or she is a watchman; the larger an organization, the more likely someone is a watchman. The bigger the effect of information and telecommunications technology had on control, the more someone is bound to be an information adapter; the more rational someone is, the more likely he or she is a watchman; the more someone is extrovert, the more often he or she is classified as an information adapter.
Wolf <i>et al.</i> (2015)	Investigates whether MAs' individual attitude and subjective norms are associated with business partner behavior and whether the actual behavior (involvement in decision-making) is associated with increased organizational performance	They found that MAs' actual business partner behavior was determined by their subjective norm (how MAs perceive that colleagues are important to them, e.g., general managers, expect and value their contributions to decision-making), rather than their personal attitude (how MAs themselves value their contributions to decision-making). Further, business partner behavior was positively associated with general managers' perceptions of the contributions from that finance organization that, in turn, were positively associated with company internal efficiency and company process improvement.
Yazdifar and Tsamenyi (2005)	Comparison of independent and dependent organizations regarding to management accounting change and the role of MAs	They found only a few significant differences between MAs working in independent vs. dependent companies: Analytical/interpretive skills were ranked as more important to management accountants in independent companies. Further, MAs in independent companies ranked integrating financial and non-financial information as more important than management accountants in dependent companies. There was no statistical difference in how management accountants were perceived (i.e., their role) by managers.

Zoni and Merchant (2007)

Controller involvement in management

They found that controllers were involved managers in larger Italian companies, and they contributed to strategic and operational decision-making. Controller involvement in strategic decision-making was positively associated with firm capital intensity and with the formalization of strategic planning and budgeting processes and negatively related to line management financial expertise. Involvement in operating decision-making was positively associated with line-management financial expertise and negatively associated with the use of controller positions as training for line roles. Additionally, they found a positive correlation between controller involvement in management and profit margin growth.

7.10 References

Accenture. (2011). *Delivering Value in a Complex World: The Next Battleground for the Finance*

Organization. Chicago, IL: Accenture LLC.

Accenture (2014). *The CFO as Architect of Business Value: Delivering Growth and Managing Complexity*. Chicago, IL: Accenture LLC.

Ahrens, T. (1997). Strategic interventions of management accountants: everyday practice of British and German brewers. *European Accounting Review*, 6 (4), pp. 557-588.

Ahrens, T., Chapman, C. S. Occupational identity of management accountants in Britain and Germany, *European Accounting Review*, 9:4, pp. 477-498.

American Institute of Certified Public Accountants. (1989). Big Eight White Paper.

Anderson, D. R. (1944). The Function of Industrial Controllershship. *The Accounting Review*, 19 (1), pp. 55-65.

¹Bechtold et al., C., Reimer, M., Schäffer, U. (2014). The Multi-Role Job Profile of Controllers: A Double-Edged Sword. *Working paper presented at the "New Directions in Management Accounting Research"* conference in 2014.

Big eight white paper. (1988). *Perspectives on education: Capabilities for success in the accounting profession*. New York: Arthur Andersen & Co., Arthur Young,

Coopers and Lybrand, Deloitte Haskins & Sells, Ernest & Whinney, Peat Marvick Main & Co, Price Waterhouse and Touche Ross.

Biddle, J. T. (1986). Recent Development in Role Theory, *Annual Review of Sociology*, 12, pp. 67-92.

Boer. G. B. (2000). Management Accounting Education: Yesterday, Today and Tomorrow, *Issues in Accounting Education*, vol. 15, no. 2, pp. 313-334.

⁶Burns, J., Baldvindsdottir, G. (2005). An institutional perspective of accountants' new roles – the interplay of contradictions and praxis. *European Accounting Review*, 14 (4), pp. 725-757.

Byrne, S., Pierce, B. (2007). Towards a More Comprehensive Understanding of the Roles of Controllers, *European Accounting Review*, Vol. 16. no. 3, pp. 469-498.

Caglio, A. (2003). Enterprise Resource Planning systems and accountants; towards hybridization? *European Accounting Review*, 12:1, pp. 123-153.

Cameron, Kim S., Robert E. Quinn., Jeff Degraff & Anjan V. Thakor. 2014. *Competing Values Leadership*. New Horizons in Management, 2nd edition.

Carmeli, A., Halevi, M, Y. 2009. How top management behavioral integration and behavioral complexity enable organizational ambidexterity: The moderating role of contextual ambidexterity, *The Leadership Quarterly*, 20, 207-218.

⁷Chang, H., Ittner, C. D., Paz, M., T. (2014). The multiple roles of the finance organization: Determinants, effectiveness, and the moderating influence of information system integration. *Journal of Management Accounting Research*, vol. 26. no. 2, pp. 1-32.

Chapman, C. S. (1998). Accountants in organizational networks. *Accounting, Organizations and Society*, 23 (8), pp. 737-766.

Chenhall, R., Langfield-Smith, K. (1998). Factors influencing the role of management accounting in the development of performance measures within organizational change programs. *Management Accounting Research*, 9 (4), pp. 361-386.

Cooper, R. (1996). Look Out, Management Accountants, *Management Accounting*, 77 (11), pp. 20-26.

¹³Cooper, P., Dart, E. (2013). Business Partnering as a Complement to the Accountant's Other Roles: International Survey Evidence, *University of Bath School of Management, Working Paper Series*.

Deloitte. (2015). The robots are coming. A Deloitte insight report. London, U.K: Deloitte LLP.

Ernst & Young. (2010). The DNA of a CFO: A Study of What Makes a Chief Financial Officer. New York,

NY: Ernst & Young.

Ernst & Young. (2016). Robotic process automation in the Finance function automation in the Finance function of the future. U.K: Ernst & Young Global Limited.

Eustler, J., Lang, B. (2015). Rating scales in accounting research: The impact of scale points and labels. *Behavioral Research in Accounting*, Vol. 27 No. 2, pp. 35-51.

Friedman, A., L., Lyne, S., R. (1997). Activity-based techniques and the death of the beancounter. *The European Accounting Review*, 6:1, pp. 19-44.

- Floyd, S. W., Wooldridge, B. (1992). Middle management involvement in strategy and its association with strategic type: A research note, *Strategic Management Journal*, vol. 13, pp. 153-167.
- Grabner, I., Moers, F. (2013). Management control as system or package? Conceptual and empirical issues. *Accounting, Organizations and Society*, 38, pp. 407-419.
- Gibson, C. B. Birkinshaw, J. (2004). The antecedents, consequences, and mediation role of organizational ambidexterity. *Academy of Management Journal*, 47 (2), pp. 209-226.
- ⁴Goretzki, L., Strauss, E., Weber, J. (2013). An institutional perspective on the changes in controllers' professional role, *Management Accounting Research*, 24, pp. 41-63.
- Graham, A., Davey-Evans, S., Toon, I. (2012). The developing role of the financial controller: evidence from the UK, *Journal of Applied Accounting Research*, vol. 13, no.1, pp. 71-88.
- ²Granlund, M., Lukka, L. (1998). Towards increasing business orientation: Finnish controllers in a changing cultural context, *Management Accounting Research*, 9, pp. 185-211.
- Granlund, M., Malmi, T. (2002). Moderate impact of ERPS on management accounting: a lag or permanent outcome, *Management Accounting Research*, 13, pp. 299-321.
- Granlund, M., Taipaleenmäki, J. (2005). Management controllership in new economy firms – a life cycle perspective, *Management Accounting Research*, 16, pp. 21-57.

Hamel, G., Breen, B. (2007). *The Future of Management*. Boston, MA: Harvard Business School Press.

¹⁰Hartmann, F. G. H., Maas, V. S. (2011). The effects of uncertainty on the roles of controllers and budgets: an exploratory study, *Accounting and Business Research*, 41:5, pp. 439-458.

He, Z-L., Wong, P-K. 2004. Exploration vs. Exploitation: An Empirical Test of The Ambidexterity Hypothesis. *Organization Science*, (15), No. 4, 481-494.

Hiller, K., Mahlendorf, M. D., Weber, J. (2014). Management Accountants' occupational prestige within the company: A Social Identity Theory Perspective, *European Accounting Review*, 23 (4), pp. 671-691.

¹¹Hopper, T. (1980). Role conflicts of controllers and their position within organization structures. *Accounting, Organizations and Society*, vol. 5, no. 4, pp. 401-411.

IBM. (2003). CFO Survey: Current State and Future Direction. NY: IBM GBS.

IBM. (2010). The New Value Integrator: Insights from the Global Chief Financial Officer Study. Somers, NY: IBM GBS.

Indjejikian, R. J., Matejka, M. (2006). Business Unit Controllers and Organizational Slack, *The Accounting Review*, July, pp. 849-872.

Institute of Chartered Accountants in England and Wales. (2011). The Finance Function: A Framework for analysis. London, U.K: Institute of Chartered Accountants in England and Wales.

Ittner, C., Larcker, D. (2002). Empirical managerial accounting research: are we just describing management consulting practice? *European Accounting Review*, 11 (4), 787-794.

- ³Järvenpää, J. (2007). Making business-partners: A case study on how management accounting culture was changed, *European Accounting Review*, 16:1, pp. 99-142.
- Katz, D., Kahn, R. L. (1978). *The Social Psychology of Organizations*, 2nd edition, New York: John Wiley.
- ⁸Lambert, C., Sponem, S. (2012). Role, Authority and Involvement of the Management Accounting Function: A Multiple Case-study Perspective, *European Accounting Review*, 21 (3), pp. 565-589.
- Lant, T. K., Montgomery, D. B. (1987). Learning from strategic success and failure. *Journal of Business Research*, 15, 503-517.
- ⁹Lind, J. (2001). Control in world class manufacturing – A longitudinal case study, *Management Accounting Research*, Vol. 12, pp. 41-74.
- Maas, V, S., Matejka, M. (2009). Balancing the Dual Responsibilities of Business Unit Controllers: Field and Survey Evidence, *The Accounting Review*, vol. 84, no. 4, pp. 1233-1253.
- Mahlendorf, M. D. (2014). Discussion of the roles of the finance organization: Determinants, effectiveness, and the moderating influence of information system integration, *Journal of Management Accounting Research*, vol. 26, no. 2, pp. 33-42.
- McKinsey & Company. (2016). Are today's CFO ready for tomorrow's demands on finance? Visited online the 20th of January, 2017: <http://www.mckinsey.com/business-functions/strategy-and-corporate-finance/our-insights/are-todays-cfos-ready-for-tomorrows-demands-on-finance>
- Messner, M. (2016). Does industry matter? How industry context shapes management accounting practice. *Management Accounting Research*, 31, 103-111.

- Mckenna, B., Rooney, D., Boal, K, B. 2009. Wisdom Principles as a meta-theoretical basis for evaluating leadership. *The Leadership Quarterly*, 20, 177-190.
- Montano, D. E., Kasprzyk, D. (2008). Theory of reasoned action, theory of planned behavior, and the integrated behavioral model, in Glanz, K., Rimer, B. K. and Viswanath, K. (Eds), *Health Behavior and Health Education: Theory, Research, and Practice*, Jossey-Bass, A Wiley Imprint, San Francisco, CA.
- Morales, J., Lambert, C. (2013). Dirty work and the construction of identity. An ethnographic study of management accounting practices, *Accounting, Organizations and Society*, vol. 38, pp. 228-244.
- ¹²Mouritsen, J. (1996). Five aspects of accounting department's work, *Management Accounting Research*, 7, pp. 283-303.
- Naranjo-Gil, D., Maas, V. S., Hartmann, F. G. H. (2009). How CFOs Determine Management Accounting Innovation: An Examination of Direct and Indirect Effects. *European Accounting Review*, 18 (4), pp. 667-695.
- Oracle and Accenture. (2013). The CFO as a catalyst for Change. Redwood Shores, CA: Oracle and Accenture.
- ¹⁴Pierce, B., O'dea, T. (2003). Management accounting information and the needs of managers, perceptions of managers and accountants compared, *The British Accounting Review*, 35, pp. 257-290.
- Quinn, R, E. (1984). Applying the Competing Values Approach to Leadership: Toward an Integrative model. *Managers and Leaders: An international perspective*, New York: Pergamon.

- Quinn, R. E., Rohrbaugh, J. (1981). A Competing Values Approach to Organizational Effectiveness, *Public Productivity Review*, vol. 5, no. 2, June, pp. 122-140.
- Quinn, R. E., Rohrbaugh, J. (1983). A Spatial Model of Effectiveness Criteria: Towards a Competing Values Approach to Organizational Effectiveness, *Management Science*, vol. 29, no. 3, March, pp. 363-377.
- Russel, K. A., Sigel, G., Kuleza, C. S. (1999). Counting more counting less: Transformations in the management accounting profession, *Management Accounting Quarterly*, Fall, pp. 1-7.
- San Miguel, J. G., Govindarajan, V. (1984). The contingent relationship between the controller and internal audit functions in large organizations. *Accounting, Organizations and Society*, 9 (2), pp. 179-188.
- ⁵Sathe, V. (1983). The Controller's Role in Management, *Organizational Dynamics*, Winter, pp. 31-48
- Shields, M. D. (1997). Research in Management Accounting by North Americans in the 1990s. *Journal of Management Accounting Research*, 9, pp. 3-61.
- Siegel, G., Kulesza, C. S., Sorenson, J. E. (1997). Are You Ready for the New Accounting? *Journal of Accountancy*, August, pp. 42-46.
- Simon, H. A. (1957). A behavioral model of rational choice, in *Models of Man*, Herbert A. Simon (ed.), Wiley: New York.
- Tanriverdi, H., Venkatraman, N. (2005). Knowledge relatedness and the performance of multibusiness firms. *Strategic Management Journal*, Vol. 26, pp. 97-119.
- Van der Stede, W. A. (2001). Measuring "tight budgetary control". *Management Accounting Research*, 12, 119-137

Verstegen, B, H, J., Loo, D, I., Mol, P., Slagter, K., Geerkens, H. Classifying Controllers by Activities: An Exploratory Study. *Journal of Applied Management Accounting Research*, vol. 5, no. 2, pp. 9-32.

Yazdifar, H., Tsamenyi, M. (2005). Management accounting change and the changing roles of controllers: a comparative analysis between dependent and independent organizations, *Journal of Accounting & Organizational Change*, 1,2, pp. 180-198.

Zorn, D. M. (2004). Here a Chief, There a Chief: The Rise of The CFO in the American Firm. *American Sociological Review*, vol. 69, 345-364.

Zoni, L., Merchant, K, A. (2007). Controller involvement in management: an empirical study in large Italian corporations, *Journal of Accounting & Organizational Change*, Vol. 3, No. 1, pp. 29-43

8. Paper 2: The relationships between finance function roles, behavioral differentiation, and performance

Henrik Nielsen^a and Thomas Borup Kristensen^a

^a*Department of Business and Management, Aalborg University*

Keywords: Roles of finance functions, Complementarity, Behavioral differentiation, Performance

Abstract

Purpose – This paper studies the complementarity and the simultaneous use of multiple finance function roles, the effects on behavioral differentiation and the number of full-time equivalents in the finance function, and in turn, the relationship between behavioral differentiation and perceived finance function performance and firm financial performance.

Design/methodology/approach – The paper uses structural equation modeling to analyze data from 408 firms operating in the manufacturing and services sectors. Furthermore, it utilizes a dyadic approach to analyze a subsample of 107 respondents to study the interrater-item agreement of the main variables. The paper also introduces a second-order factor model to the management accounting literature in order to investigate the complementarity among finance function roles.

Findings – The paper shows that the simultaneous use and complementarity of finance function roles are positively related to behavioral differentiation. Only one role is positively related to behavioral differentiation in isolation. Moreover, the simultaneous use and complementarity among the entire set of finance function roles are also positively related to the number of full-time equivalents employed by

the finance function. However, behavioral differentiation is positively related to perceived finance function performance and return on invested capital. Thus, there appears to be no trade-off between emphasizing only a few finance function roles compared with emphasizing them all.

Research limitations/implications – The paper applies a paradoxical perspective to the finance function roles in order to predict that the roles are complementary, and the paper expands the debate on whether different finance function roles are substitutes or complementary. It also shows that finance functions potentially create value for firms with respect to perceived finance function performance *and* return on invested capital.

Practical implications – Decision-makers in firms should not hesitate to expand the roles of finance functions. Although the simultaneous use and complementarity of all roles increase the number of full-time equivalents employed in the finance function, the benefits from emphasizing all roles outweigh the costs.

Originality/value – This paper provides large-scale evidence of the complementarity among multiple finance function roles and shows how finance functions can create value for firms. It also relies on the competing values framework to develop items that measure finance function roles. Furthermore, it expands the two-role taxonomy often applied in previous research as this paper identifies four finance function roles. The paper is the first to use a second-order model that captures the covariance and multilateral interactions among finance function roles to show that they are complementary.

8.1 Introduction

Research on the roles of finance functions dates back more than half a century (Anderson, 1944; Simon *et al.*, 1954). Researchers have focused on the broadening roles and responsibilities for finance functions, and the antecedents of these developments (Granlund and Lukka, 1998; Maas and Matejka, 2009; Hartman and Mass, 2011). It is common for this research stream to distinguish between two types of finance function roles on opposite ends of a continuum. The roles are often referred to as the corporate policeman and the business partner. Corporate policemen are assigned tasks such as monitoring functional performance and ensuring that functions comply with budgetary boundaries and external regulations. Business partners, however, are typically seen as providing strategic advice and supporting managerial decision-making. A few previous studies have also focused on the interplay between the dual roles, and the studies can be divided into two groups: One suggests that the roles are substitutes (Maas and Matejka, 2009) while the other suggests that the two roles are complements (Sathe, 1983). The contrast between the corporate policeman and the business partner role is often referred to as an independence-dependence dilemma (Bechtold *et al.*, 2014), and much previous research focuses on controllers as units of analysis (Granlund and Lukka, 1998; Caglio, 2003). However, notable exceptions focusing on the entire finance function are Chang *et al.* (2014), Lambert and Sponem (2012) and Mouritsen (1996). We focus on the finance function as the unit of analysis, and the main purpose of this study is contribute to the debate on complementarity between roles of finance functions (Mahlendorf, 2014). We utilize a paradoxical perspective (Schad *et al.*, 2016) and study the relation between the simultaneous use and complementarity of finance function roles and behavioral differentiation (BD) and, in turn, the relation between BD and performance. In previous research, finance function roles were theoretically vaguely developed (Mahlendorf, 2014). We use

the competing values framework (CVF; Cameron *et al.*, 2014) as guidance for developing items pertaining to the roles of finance functions. We use the CVF because it captures our paradoxical perspective on finance function roles, and consequentially, we develop four finance function roles.

According to Ennen and Richter (2010), there are two approaches to test for complementarity: One is a reductionist approach focusing on the interaction between two variables while the other is a holistic approach focusing on the complementarity between multiple variables (Ennen and Richter, 2010). We apply the holistic approach and utilize the procedure developed by Tanriverdi and Venkatraman (2005) to construct a second-order factor structural equation model (SEM) capturing the covariance and multilateral interactions between multiple finance function roles, as well as the effects of the second-order factor on BD. This model is compared with a first-order SEM model that conceptualizes finance function roles as first-order factors and explores their additive effects on BD. We argue that this test for complementarity is superior to other procedures such as various regression analyses.

We use a sample of 408 companies from the Danish manufacturing and services sectors, and we contribute to the literature on finance functions in several ways. First, we hypothesize and find that the simultaneous emphases and the complementarity among all finance function roles are positively related to BD. Only one finance function role is additively related to BD. Second, we hypothesize and find that BD is related to the perceived performance of the finance function and, furthermore, that BD is positively related to the company financial performance (return on invested capital). These two contributions respond to Hartmann and Maas (2011) who called for studies shedding light to how finance function roles create value for organizations. Third, we expand the taxonomies

previously used on the finance function as we use the CVF to define four roles instead of the two roles used in much previous research. Thus, we respond to Byrne and Pierce (2007) who called for a more comprehensive view of contemporary finance function roles. We also measure the roles consistently via activities (Maas and Matejka, 2009; Mahlendorf, 2014), and we use a dyadic approach (Schäfer, 2007) as we survey the chief financial officers (CFOs) and chief operating officers (COOs) in the participating firms. We use a dyadic approach and the average deviation index (ADI; Burke *et al.*, 1999) to test the interrater agreement of items with respect to our main exogenous and endogenous variables. We find that the interrater agreement is more than acceptable. Fourth, we find that the complementarity among finance function roles is positively related to an increase in the number of full-time equivalents (FTEs) employed in the finance functions. However, there does not appear to be a trade-off between the simultaneous emphases on all four roles versus emphasizing only a few of them because a greater BD is related to an increase in firm financial performance. Last, we are the first to utilize the second-order technique for testing complementarity among finance function roles.

The remainder of this paper is structured as follows. In section 2, we review the relevant literature and construct the hypotheses. We present the methods in section 3 and the results in section 4. We discuss and conclude our findings in section 5, and in section 6, we discuss limitations and an avenue for future research.

8.2 Literature review and hypotheses development

This section begins with a brief summary of the research on the roles of finance functions. We then discuss the scarce research on complementarity among finance function roles and explain the concept of behavioral differentiation. In the subsection that follows, we present the paper's paradoxical perspective and relate

that to the roles of finance functions. In the next subsection, we present the CVF and describe how it is used to measure the roles of finance functions.

8.2.1 The roles of finance functions, complementarity and behavioral differentiation

Research on finance functions' roles dates back to the 1940s (Anderson, 1944), and it began to capture momentum in the 1990s (Mouritsen, 1996; Chapman, 1998; Granlund and Lukka, 1998). It is evident that the roles have changed from a core focusing on score-keeping and statutory duties to also emphasizing an engagement in firm operations and strategy (Sorenson, 2009). Yet scorekeeping and statutory roles appear to remain important (Mouritsen, 1996; Chang *et al.*, 2014) which imply that the set of roles is larger compared with, say, the 1980s (The Big Eight White Paper, 1989). To some extent, there is agreement on the drivers of the change; examples are increased business and market complexity, organizational changes, new management philosophies (Burns and Baldvindsdottir, 2005) and myths about the benefits of change (Järvenpää, 2007). Research has also shown that the relative emphasis on the different finance function roles depends on the context (see e.g. Byrne and Pierce, 2007), but there is consistent evidence of multiple roles in contemporary finance function practice¹⁶ (Bechtoldt *et al.*, 2014).

Although researchers recognize that the set of finance function roles appears to be increasing, only a few studies have shed light on the complementarity among the multiple finance function roles. Describing different responsibilities and

¹⁶ Several studies in this section describe the roles of management accountants (Granlund and Lukka, 1998; Byrne and Pierce, 2007) or controllers (Sathe, 1982; Bechtoldt *et al.*, 2014). We decided to include these studies as controllers and management accountants (see Ahrens and Chapman, 2000, for elaboration on the differences between and similarities of the two terms) are, of course, a part of the finance function.

characteristics of the controller, Sathe (1983) suggested that strong controllers would benefit from their dual responsibilities, functional and local. He argued that the strong controller would be able to overcome conflicts between local and functional responsibilities, and that by getting involved in local decision-making, the strong controller would be in a better position to perform functional duties. In a survey study, Maas and Matejka (2009) empirically tested Sathe's arguments, and they found that the dual responsibilities were substitutes. Subsequently, they argued that they could "thus reject the alternative view that there are significant complementarities between functional responsibilities of business-unit controllers and their support of local decision making" (p. 1247). They tested for complementarity by modeling an additive relation between the functional responsibility and local decision-making support of controllers in a structural model.

Chang *et al.* (2014) examined antecedents of the importance of three finance function roles in a survey study: reporting, compliance and internal control/risk management; performance management; and strategic partner. They tested for complementarity among the three roles on perceived role effectiveness. They argued that a positive correlation between the three roles and a positive additive relation between the three roles and perceived role effectiveness were evidence of complementarity¹⁷. In footnote 10, moreover, they described the results of another test recently discussed in the management accounting literature by Grabner and Moers (2013). They correlated the residuals of the three roles from their main regressions and found positive significant relations indicating that the roles were

¹⁷ Chang *et al.*'s (2014) and Maas and Matejka's (2009) primary methods for testing complementarity do not reveal complementarity.

complementary¹⁸. In a multiple case-study, Byrne and Peirce (2007) studied antecedents, characteristics and the consequences of the roles of finance functions. Managers in most firms acknowledged an inherent conflict between the finance functions' business and controlling responsibilities, but they found that when finance function employees were more involved in business decisions, the employees developed a greater organizational understanding that strengthened the effectiveness of control, and as a consequence, the finance function created "more workable control systems" (p. 492). Byrne and Peirce (2007) further elaborated that with more interaction accounting information was used more in a broader organizational domain. Thus, the quality of control *and* the quality of finance function employees' business activities were increased by increased interaction.

To establish clear evidence of complementarity between the roles of finance functions, it is necessary to compare the additive effects of the roles with the effects stemming from the complementarity among the roles (Tanriverdi and Venkatraman, 2005). Furthermore, a holistic perspective encompassing a larger set of roles is essential as a reductionist perspective comes with a risk of neglecting that the complementarity between two roles might be a function of a third role (Ennen and Richter, 2010). Thus, Maas and Matejka's (2009) method for testing complementarity is problematic because it is reductionist. The method includes only two roles which might have affected the authors' results as the complementarity between the functional reporting role and the local support role could be a function of a third role. Furthermore, Maas and Matejka's (2009) and Chang *et al.*'s (2014) methods do not compare additive with complementary effects. Likewise, although describing the benefits from the interplay between a control

¹⁸ This method for testing complementarity assumes a theory that predicts that managers make, more or less, optimal decisions (Grabner and Moers, 2013).

focus and a partnership focus, Byrne and Pierce's (2007) findings are difficult to generalize as they are based on 18 companies. Altogether, this provides a unique opportunity for establishing evidence of the complementarity among finance function roles.

As we will elaborate later, we argue that the multiple roles of finance functions are complementary, and by integrating and simultaneously using the roles and recognizing their complementarity, finance functions will achieve a greater BD. BD is the ability to apply roles differently, that is, adaptively, flexibly, situation specifically and appropriately (Hooijberg *et al.*, 1997) and applying the right role when it is called for. BD is usually related to managers' abilities (Hooijberg, 1996) and has been found to increase managerial effectiveness (Denison *et al.*, 1995). However, BD has also been described as a group characteristic (Carmeli and Halevi, 2009). In this paper, BD is a characteristic of the finance function, and when a finance function has a great BD, the function understands the demands for its role performance from internal customers, it performs the roles accordingly, and it delivers activities and services with a high quality. In the hypotheses section, we argue that a greater BD increases the perceived performance of the finance function and the financial performance of the company.

8.2.2 Paradoxes and the roles of finance functions

Before the roles of finance functions are described with a paradox lens, it is necessary to understand what a paradox is and what it is not. We use the definition put forward by Schad *et al.* (2016) who describe a paradox as a "persistent contradiction between interdependent elements" (p. 6). Typically, paradoxes are latent, but they become salient, for example, if the organization faces uncertainties (Denis *et al.*, 2012) or resource constraints (Smith & Lewis, 2011; Schmitt and

Raisch, 2013). A paradox is different from related phenomena, such as a dilemma or a dialectic perspective. A paradox is different from a dilemma because a dilemma implies that an organization can choose temporarily between competing choices each with advantages and disadvantages, but at some later point in time, the dilemma will resurface. Furthermore, a paradox is different from a dialectic perspective because a dialectic perspective implies that the contradiction between elements (thesis and antithesis) will be solved by integration (synthesis) which, over time, faces a new contradiction (Smith and Lewis, 2011). The main difference between a paradox and a dilemma, and a dialectic perspective is then that a paradox cannot be temporarily resolved; instead, organizations cope, that is, “learn to live” with the paradox.

A noteworthy example of a paradox from organization research is ambidextrous organizations (Gibson and Birkinshaw, 2004, see also Ylinen and Gullkvist, 2014, for an example from the management accounting literature). Ambidextrous organizations cope with the conflicting demands of exploitation and exploration either structurally by devoting some organizational units to exploitation and other units to exploration (O’Reilly and Tushman 2008), or contextually by having structures permeating the entire organization enabling employees to simultaneously exploit and explore (O’Reilly and Tushman, 2013)¹⁹. Another example, introduced to the management accounting literature by Ahrens and Chapman (2004), is the emphasis on alignment and standards while maintaining flexibility, that is, enabling formalization (Adler and Borys, 1996).

¹⁹ The third possibility of dealing with the conflicting demands of exploration and exploitation is temporal, meaning that at some point in time, organizations exploit whereas at another point in time, they explore (Laplume and Dass, 2012). However, the third “solution” to the paradox of exploration and exploitation is not within the definition of a paradox cf. Schad *et al.* (2016). The temporal perspective implies that the conflicting demand of exploitation and exploration is a dilemma.

As an illustration of a paradox that finance functions face, we can use Sathe's (1983) characterization of a strong controller. A strong controller faces competing demands in that she is responsible for supporting and helping a local business unit while, at the same time, she has monitoring and reporting responsibilities for the same business unit as a function of requirements from headquarters²⁰. She copes with the conflicting demands by being actively involved in local decision-making while simultaneously retaining a sense of objectivity and independence. Another example is Hartmann and Maas's (2011) study of business unit controllers. They found that business unit controllers attributed almost equal importance to a role ensuring that business units adhered to company and legal regulations and a role helping the business unit with strategic advice. Regarding evidence pertaining to the finance function as a unit of analysis, Chang *et al.* (2014) found that a role emphasizing monitoring of performance and a role emphasizing strategic decision support were attributed almost equal importance by the 832 respondents. In multiple case studies by Byrne and Pierce (2007) and Granlund and Lukka (1998), management accountants had control and reporting responsibility *and* responsibility for providing business advice. Altogether, it appears from research on finance function roles that finance functions face paradoxes. Now we turn to the CVF and describe how we use it to measure the roles of finance functions and develop the hypotheses in the subsequent sections.

8.2.3 The competing values framework and the roles of finance functions

Much research considers the roles of the finance function as consisting of two roles on the opposite ends of a continuum often referred to as a corporate policeman versus a business partner (Granlund and Lukka, 1998; Hartmann and Maas, 2011).

²⁰ In a sense, this can be characterized as a "belonging" paradox (cf. Schad *et al.*, 2016).

In this paper, the roles of the finance function are expanded as we define four roles. We use the CVF to operationalize and measure finance functions' roles because it captures tensions and paradoxes that organizations face (Cameron *et al.*, 2014). The CVF highlights contradictory yet interdependent organizational components by shedding light on differences among a dimension of control versus flexibility and a dimension of internal versus external focus. The integration of the two dimensions forms four quadrants that have different foci (Hooijberg, 1996). The four quadrants and their different foci represent the distinctions between the four different finance function roles used in this paper. The external and flexibility axes form the adhocracy quadrant which emphasizes growth, innovation and adaption to the environment (Lawrence *et al.*, 2009). The finance function role related to the adhocracy quadrant is characterized by providing advice on strategy, initiating strategic changes and developing growth opportunities for the company. The external and control axes form the compete quadrant which focuses on cost reduction, goal-setting and productivity (Kalliath *et al.*, 1999). The finance function role related to the compete quadrant develops cost-cutting and profit-increasing plans, and motivates and helps employees reach financial and non-financial goals. The internal and control axes define the control quadrant which stresses monitoring of performance, stability and control (Lawrence *et al.*, 2009). The finance function role that is related to this quadrant prepares and implements budgets, performs variance analyses and statutory tasks, and monitors the performance of other functions. The control role's emphasis is described as the foundation on which other roles are built (Granlund and Lukka, 1998) yet is rarely measured in the literature (Bechtold *et al.*, 2014). Last, the internal and flexibility axes form the collaborate quadrant which emphasizes internal alignment, autonomy and cooperation (Cameron *et al.*, 2014). The finance function role related to this quadrant focuses on aligning financial and operational systems with the overall

business, collaborating and establishing consensus among other functions in the firm. The CVF has been applied and validated in a wide range of research (Kalliath *et al.*, 1999) since it was developed by Quinn and Rohrbaugh (1981). The CVF and the underlying values of the four quadrants are depicted in Figure 1.

Figure 1: The competing values framework

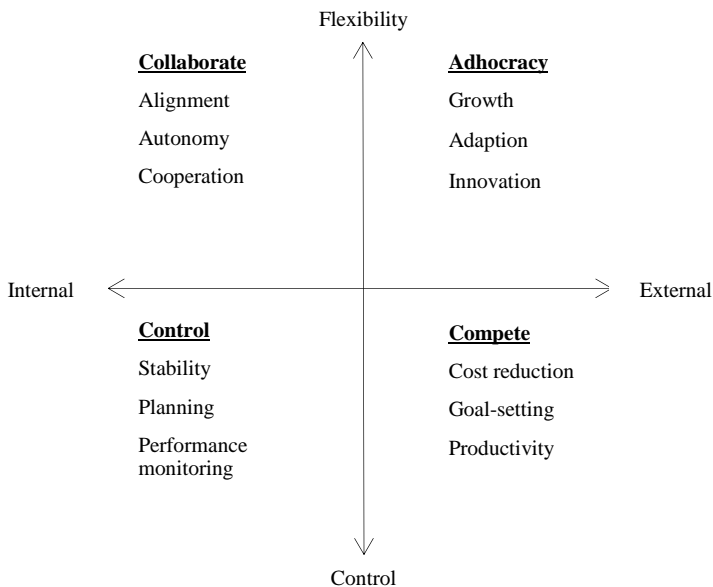

8.2.4 Complementarity hypotheses

Studies describe elements of paradoxes as complementary (Cao *et al.*, 2009; Gerbert *et al.*, 2010) and interwoven (Denison *et al.*, 1995; Lewis, 2000). This description implies that these elements are not orthogonal to one another but serve different purposes (Patel *et al.*, 2013). Furthermore, organizations that integrate

paradoxical elements create a greater sense and understanding of causality and the organizational wholeness as paradoxes inform one another (Chreim, 2005).

We argue that the four finance function roles inform one another which foster a comprehensive understanding of the organization's demands for the roles and increases the quality of the services and roles performed. For example, advice on strategic decisions and investments, and the initiation of strategic change (the adhocracy role), and motivational efforts and advice (the compete role), will have a more sound foundation if based on knowledge of the current performance of the company (the control role). In other words, the quality of advice on strategic decisions, investments and motivational efforts will be greater, and the initiation of strategic changes for the company will be more aligned with what is currently possible for the company to reduce the costs and time of obsolete advice. Granlund and Lukka (1998), Mouritsen (2004), and Weber (2011) state that traditional activities (in this research, activities performed by the control role) are *sin qua non* with respect to performing more business-oriented activities (the adhocracy role and the compete role). Furthermore, mastering traditional activities increases the legitimacy of the finance function's advice to operations (the compete role) and regarding strategy (Goretzki *et al.*, 2013; see also Keyes *et al.*, 2000). Yet monitoring and analyzing the performance of a strategic decision are also more effective if the finance function is engaged in the decision (the adhocracy role) because the function has a greater understanding of where, why and when control is required (Byrne and Peirce, 2007).

Aligning the company's management control system with the business (the collaborate role) also becomes a less daunting task if the finance function has a thorough understanding of the company's operations (the compete role) and strategic intent (the adhocracy role), and if the finance function administers the

company's financial reporting system (the control role). The control role and the compete role can ensure that the benefits from the adhocracy role and the collaborate role will be achieved. For example, in some instances the benefits from the adhocracy role will not occur if the financial boundaries are insufficiently delineated by the control role, or if the plan for achieving strategic objectives is not implemented accordingly (the compete role). On the contrary, an excessive use of the control and compete roles might impede the benefits of the adhocracy role, for example, caused by a narrow focus on cost reduction and reduced attention to innovation and strategic opportunities.

Integrating contradictory and paradoxical elements is not without challenges in that the integration can cause conflicts and tensions (Henri, 2006) that are difficult to overcome. However, conflict literature scholars suggest that avoiding conflict reduces decision quality and communication (Dedreu, 1991; Nicotera, 1995). The conflicts that might arise from the integration of contradictory and paradoxical elements can foster dialogue and increase organizational focus (Henri, 2006). Thus, we contend that the four finance function roles are complementary and that the complementarity leads to a greater BD.

When complementarities exist among finance functions' roles, organizations have to coordinate the performance of the roles and integrate them. Therefore, we develop a second-order factor (Mishra and Shah, 2009; Tanriverdi and Venkatraman, 2005). This second-order factor captures the covariance and multilateral interactions among the first-order factors, that is, the adhocracy role, the compete role, the control role and the collaborate role. Furthermore, to establish clear evidence of complementarity, we need to compare the additive relations between the first-order factors and BD, with the relation between the second-order factor and BD, and we have to make sure that the complementarity effects

outweigh the additive effects (Tanriverdi and Venkatraman, 2005). Thus, we develop two competing hypotheses to investigate whether BD for finance functions is dependent on the complementarity among finance functions' roles or whether the individual role has an additive effect on BD. The first hypothesis (H1), which we label the "strong form," states that the complementarity among finance function roles has a direct positive relation with BD whereas the second hypothesis (H2), which we label the "weak form," states that the four finance function roles have additive positive relations with BD:

H1 (strong form): The complementarity of the adhocracy role, the compete role, the control role and the collaborate role has a positive effect on behavioral differentiation.

H2 (weak form): The adhocracy role, the compete role, the control role and the collaborate role have additive positive effects on behavioral differentiation.

We also contend that the simultaneous use of all four finance function roles affects the number of FTEs employed in finance functions. We have no theory or empirical guidance for this relation. On the one hand, we should expect that the simultaneous use of all four roles increases the number of FTE as, *ceteris paribus*, the finance functions have a larger set of activities to cover. On the other hand, we could expect that emphasizing all four roles simultaneously also increases finance functions' knowledge of which activities not to perform in certain circumstances. Thus, we cannot predict the direction of the relation, but we expect that the simultaneous use of all roles is related to the number of FTEs.

H3: The complementarity of all four finance function roles is related to the number of FTEs.

8.2.5 Behavioral differentiation and performance

We have described how the simultaneous use and complementarity among paradoxical finance function roles are related to a greater BD which enables understanding and clarity of the demands for their efforts. This greater understanding and clarity increase effectiveness (Poole and Van de Ven, 1989). In addition, Drach-Zahavy and Freund (2007) argue that integrating paradoxes increases space for maneuvering which fosters increased effectiveness. We contend that a greater BD enabled by the complementarity of the four finance function roles increases the perceived performance of the finance function. Specifically, finance function employees are more likely to be effective if they understand what is needed to be done, and how and when they are expected to perform different roles. This is particularly important as finance function employees are subjected to an increasing set of tasks (Burns and Baldvinsdottir, 2005), and some of the tasks conflict (Byrne and Pierce, 2007). In contrast, finance function employees who are uncertain about the constituents of and expectations for their roles are likely to hesitate and not take initiative due to uncertainty (Hall, 2008). Furthermore, Tubre and Collins (2000) find that ambiguity leads to deteriorated work effectiveness. Altogether, this leads to the fourth hypothesis:

H4: Behavioral differentiation is positively related to finance function performance.

We also argue that an increased BD is positively related to financial performance. BD will enable the finance function to overcome inconsistencies stemming from demands for their support of other functions in the company, and the quality of the finance function services also increases. In turn, and relying on rational decision theory (Hedström and Swedberg, 1996), we assume that when the quality of the finance function services increases it is likely that they will be used more for

managerial decision-making (Weissenberger and Angelkort, 2011), and it is likely that this will improve the overall financial performance of the company. In addition, research from the services literature shows that understanding the demands of the internal customer is related to a reduction of waste and costs in the organization and an improved external customer service quality leading to sustained competitiveness in the market (Jun and Cai, 2010). This leads to our fifth hypothesis:

H5: Behavioral differentiation is positively related to financial performance.

Figure 2 depicts our research model. Note that it is shown without the additive hypotheses.

Figure 2: Research model

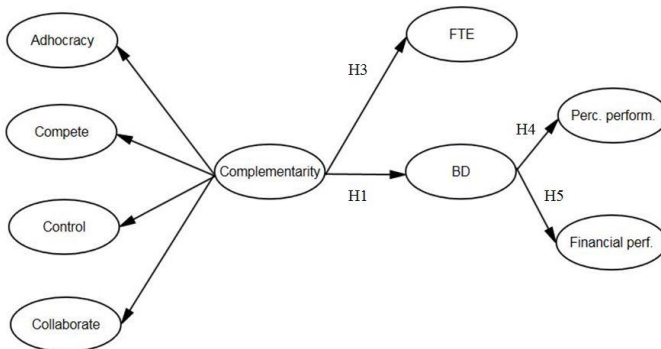

8.3 Methods

The test of the complementarity hypothesis demands additional tests compared with a traditional SEM where researchers begin with an exploratory factor analysis and a confirmatory factor analysis and then test the hypothesized relations in a full structural model. Therefore, we decided to depict the sequence of our statistical tests in Figure 3.

Figure 3: Sequence of statistical tests

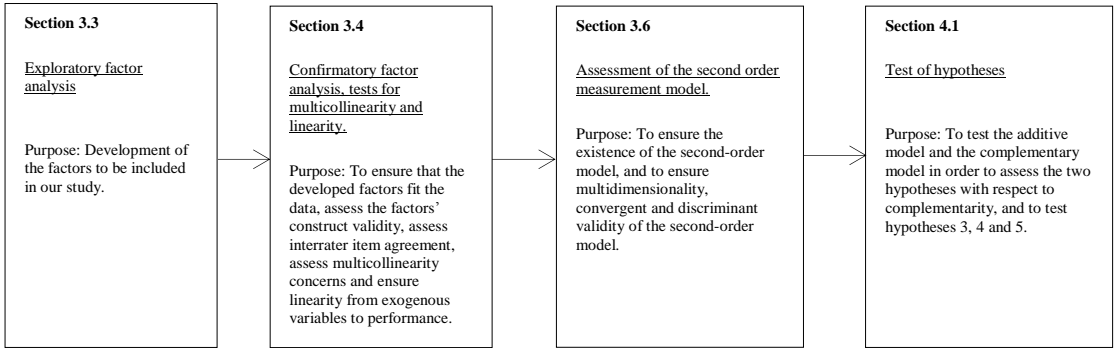

The sample for this research is found in the Danish database of registered firms. For the entire survey, we included private and publicly held companies, as well as government and nonprofit firms. Firms had to have more than 50 employees, and we contacted the CFO as our target respondent which is similar to other survey papers on the roles of finance functions (Mouritsen, 1996; Chang *et al.*, 2014). In total, 1775 firms were suitable for the survey. Contact information for CFOs was collected via telephone, and firms also received information about the research. The questionnaire was pre-tested on a small sample of management accounting academics to ensure the content and face validity of the items. We used the feedback from the researchers to change some words on the questionnaire and then tested the questionnaire on a small sample of CFOs to ensure that meanings were clear. Data collection in the initial two rounds was performed via e-mail from June 2016 until December 2016. The e-mail included a brief description of the research and a link to an online survey instrument. A third round of data collection was performed via postal mail in January 2017. In total, 525 firms responded to the survey yielding a response rate of 29.5 percent. The response rate is within the 10 to 30 percent range reported in recent survey studies in management accounting targeting senior management members (Hansen and Van der Stede, 2004; Henri, 2006; Widener, 2007; Grabner and Speckbacher, 2016).

In this study, we use return on invested capital as a dependent variable and accounting data as control variables. Therefore, we exclude government and nonprofit firms and use a sample of 408 firms. We assess possible non-response bias via *t*-tests and compare responding and non-responding firms by number of employees ($t = .651, p = .515$), 2015 revenue ($t = .392, p = .695$) and 2015 return on assets ($t = .143, p = .633$). None of these tests indicate non-response bias. On average, respondents are 48.5 years of age, have been employed 9 years at their current firm and have 5.9 years of tenure in their current position. Thus, respondents have several years of experience on which to base their answers to the survey. Table I illustrates the sample characteristics.

Table 1: Sample characteristics

	Manufacturing <i>n</i> = 193		Service <i>n</i> =215
Iron and Rubber	30%	Retailing	42%
Machines	30%	Finance	24%
Food	13%	Transportation	14%
Textiles	7%	Utilities	10%
Electronics	6%	Other	7%
Chemicals	4%	Communication	2%
Health-care	4%	Property	1%
Furniture	3%		
Media	2%		
Other	1%		
<i>Total</i>	100%		100%

After collecting responses from the CFOs, we found names and contact information for COOs in the responding firms via the Danish database of registered companies. We performed two rounds of data collection; one via e-mail that included a link to the online survey instrument and one via postal mail. In total,

107 responses were received. In this study, these responses are used to assess interrater agreement for the items of the variables representing the roles of finance function, perceived finance function performance and BD. *T*-tests are used to compare the subsample of firms in which the COO and the CFO responded with the sample of firms where only the CFO responded. We compare these groups by number of employees ($t = .839$, $p = .402$), 2015 revenue ($t = 452$, $p = .652$) and 2015 return on assets ($t = 523$, $p = .601$). None of these tests produce significant results. On average, COOs are 49.5 years of age, have been employed by their current firm for 12.6 years and have 6.9 years of tenure in their current position.

8.3.1 Variable measurement

The questionnaire has 158 items, but we use only a portion in this research. All items are measured on a 7-point labeled Likert scale. Eustler and Lang (2015) recommend this approach as labeled scales are superior to unlabeled scales because labeled scales reduce centrality and extreme response bias. Furthermore, a range of 1 to 7 increases the variances in the responses (Eustler and Lang, 2015).

8.3.1.1 Behavioral differentiation

We measure BD using four items. The first item captures the perceived ability of the finance function to conform to the organization's expectations for finance function work represented by behavior. The second item captures whether the level of activities performed by the finance function conforms to the demands from the organization. The third item captures the extent to which the finance function complies with internal customer demands on time, and the last item captures the extent to which the finance function performs activities with great quality.

8.3.1.2 Full-time equivalents

We ask respondents to indicate the total number of FTEs employed in the finance function. This number includes finance function employees at headquarters and finance employees situated in decentralized business units.

8.3.1.3 Finance function performance

Finance function performance is measured utilizing three items. The first item captures the perceived reputation of the finance function in the firm, and the second item captures the perceived success of the finance function. The third item captures the perceived performance of the finance function relative to finance functions in similar firms.

8.3.1.4 Financial performance

As recommended by Dess and Robinson (1984), we use accounting data to measure financial performance. Financial performance is operationally defined by return on invested capital (ROIC) in the company year of 2016. We calculate ROIC using after-tax operating profit divided by invested capital (Hawawini and Viallet, 2011). As the denominator, we use average assets in 2016 (beginning 2016 + end 2016 divided by 2) and subtract the average accounts payable.

8.3.1.5 Roles of the finance function

We performed a literature review of empirical research to capture a sound base of items pertaining to the roles of finance functions. “Controller” and “role”, and “management accounting”/“accountant” and “role” were searched for in paper titles and abstracts in the EBSCO host business source premier database and in the ABI/INFORM database. We reviewed 31 papers of which 23 were published in

highly ranked journals²¹. Mahlendorf (2014) argues that finance function roles have the characteristics of practice-defined variables. He refers to Luft and Shields (2007) who argue that, in comparison with practice-defined variables, “theory-defined variables are more likely to have well-defined, unitary and stable meanings making it possible to identify consistent cause and effect relations” (p. 43). Therefore, we rely on the CVF as a lens for identifying items and descriptions of finance function activities that fit each quadrant’s underlying values because it captures the tensions and paradoxes that organizations face (Cameron *et al.*, 2014). We use activities to reduce the effects of social desirability bias (Mahlendorf, 2014), and we use a frequency scale in order to capture the frequency of which respondents perceived the roles to be part of their work rather than to measure the number of times a given activity was performed (Floyd and Wooldridge, 1992).

The adhocracy role is measured using five items. The first item captures the frequency at which the finance function provides strategic advice to operations, and this item is based on Burns and Baldvindsdottir (2005). The second item is adapted from Maas and Matejka (2009), and it captures the frequency at which the finance function develops new investment potentials. The third item is adapted from Chang *et al.* (2014) and captures the frequency at which the finance function helps the firm set strategic directions and imperatives. The fourth item is based on Goretzski *et al.* (2013) to capture the frequency at which the finance function contributes with advice on growth potential for the firm. The last item is based on Granlund and Lukka (1998) and captures the frequency at which the finance function initiates strategic changes.

²¹ European Accounting Review: 10, Management Accounting Research: 7, Accounting, Organizations and Society: 3, The Accounting Review 2, and Journal of Management Accounting Research: 1.

We measure the compete role using five items. Item 1 was adapted from Maas and Matejka (2009) intended to capture the frequency at which the finance function develops cost-saving plans for the firm. Item 2 was based on Hartmann and Maas (2011) and captures the frequency at which the finance function provides advice to other functions for achieving their non-financial and financial objectives. We developed item 3, and it captures the frequency at which the finance function develops profit optimization plans for the firm. Item 4 was based on Lind (2001) and captures the frequency at which the finance function helps other functions finish projects. We developed item 5, and it is intended to capture the frequency at which the finance function motivates other functions.

The control role is measured using five items. We developed item 1 to capture the frequency at which the finance function performs statutory tasks such as monthly close. Item 2 was based on Mouritsen (1996) intended to capture the frequency at which the finance function performs variance analysis. Item 3 was adapted from Chang *et al.* (2014), and it captures the frequency at which the finance function monitors the performance of other functions. We developed item 4 to capture the frequency at which the finance function administers the reporting system in the firm. Item 5 was based on Mouritsen (1996) intended to capture the frequency at which the finance function participates in preparing and implementing the budget in other functions.

We measure the collaborate role using five items. We developed items 1 and 2. They capture the frequency at which the finance function establishes common objectives when communicating with other functions in the firm and the frequency at which the finance function exhibits leadership toward other functions in the firm, respectively. Item 3 was adapted from Chang *et al.* (2014) capturing the frequency at which the finance function aligns management control systems to the firm's

business. Item 4 is based on Peirce and O’dea (2003) to capture the frequency at which the finance function collaborates with other functions in order to establish consensus between them. We developed item 5 to measure the frequency at which the finance function listens to, and legitimizes, other functions’ finance-related suggestions.

8.3.2 Control variables

We control for three contingency variables; size, environmental uncertainty (Donaldson, 2001) and strategy (Chenhall, 2003)²². Size is proxied for by the logarithm of the total number of employees in the firm (Tanriverdi and Venkatraman, 2005), environmental uncertainty is captured by the standard deviation of sales growth of firms within the same sector during the past three years (Cao *et al.*, 2009) and strategy is assessed with the self-typing paragraph used by, for example, Slater and Olson (2000) to capture whether respondents’ firms are characterized as prospectors, analyzers, defenders or reactors. We relate size, environmental uncertainty and strategy to all endogenous variables. Furthermore, we control for the level of enterprise resource planning (ERP) integration. A high level of ERP integration might affect the perceived performance of the finance function as ERP has been found to free capacity for finance function employees (Byrne and Pierce, 2007). Thus, we model a relation between ERP integration and perceived performance. We ask respondents to indicate the level of ERP integration using two items. Item 1 captures the quality of the data and information provided by the system whereas item 2 captures whether the degree of data and information provided by the system meets the needs of the finance function. We

²² Chenhall (2003) argues that strategy is somewhat different from other contingency variables. Strategy is a means for decision-makers to influence the environment and the organization.

include a dummy for respondents' position (CFO or not) as only 66.4 percent of respondents were CFOs²³, and we control for the respondents' tenure in their current position and whether the firms operate in the services vs. manufacturing sector. We model relations between these four variables and all endogenous variables.

8.3.3 Exploratory factor analysis and confirmatory factor analysis

We perform an exploratory factor analysis that includes all latent variable items with oblique rotation. The exploratory factor analysis yields seven factors with eigenvalues greater than one: the adhocracy role, the compete role, the control role, the collaborate role, finance function performance, BD and ERP integration. Altogether, the seven factors explain 62.9 percent of the variance in the data, and Cronbach's alphas for the factors range between .703 and .849 showing adequate to excellent reliability (Kline, 2011); see Table II.

Table 2: Exploratory factor analysis and descriptive statistics

Factor	Adhocracy role	Compete role	Control role	Collaborate role	BD	Perceived performance	ERP integration	Mean	Std. deviation
<i>Indicator</i>									
ROLE1	.792							5.708	1.171
ROLE2	.670							4.193	1.657
ROLE3	.828							5.832	1.249
ROLE4	.819							4.741	1.606
ROLE5	.548							4.228	1.427
ROLE6		.698						5.079	1.329
ROLE7		.568						5.115	1.376
ROLE8		.729						4.780	1.492
ROLE9		.581						4.529	1.421
ROLE10		.817						4.067	1.686
ROLE11			.774					6.830	.518

²³ Other respondents identified themselves as “senior finance manager” (6.6 percent), “controller” (2 percent), CEO (2 percent) and “other” (23 percent).

ROLE12			.694					6.550	.952
ROLE13			.608					6.071	1.380
ROLE14			.560					6.494	1.016
ROLE15			.674					6.631	.868
ROLE16				.581				4.864	1.210
ROLE17				.694				5.202	1.247
ROLE18				.750				5.225	1.277
ROLE19				.857				5.954	1.096
ROLE20				.747				5.878	1.033
BD 1					.764			5.781	1.018
BD 2					.843			5.778	.987
BD 3					.847			5.935	.924
BD 4					.728			6.236	.763
PPERF1						.738		5.000	.934
PPERF2						.847		5.040	.722
PPERF3						.715		5.111	.776
ERP1							.801	5.658	1.418
ERP2							.891	4.651	1.535

KMO of sampling adequacy for factors: .853. Bartlett's Test of Sphericity is significant $p < .000$

Only loadings exceeding .400 are shown

8.3.4 Confirmatory factor analysis

We run a confirmatory factor analysis in AMOS 23 including all latent variables. In this procedure, factors are correlated in a model without structural parameters (Hair *et al.*, 2014). We use several fit indices (Kline, 2011) to ensure that the measurement model fits the data. We evaluate the chi-square to degrees of freedom (Bollen, 1989), which should be less than 3 (Kline, 2005); the root mean square error of approximation (RMSEA), which should be less than .08 (Browne and Cudeck, 1993); and the standardized root mean square residual, which should be less than .1 (Schermelleh-Engel *et al.*, 2003). Furthermore, we assess the comparative fit index (CFI; Bentler, 1990), the incremental fit index (IFI; Bollen,

1989) and the Tucker-Lewis index (TLI; Tucker-Lewis, 1973) where values above 0.9 indicate acceptable fit (Bentler, 1992; Kline, 2005). Last, we evaluate the consistent Akaike information criterion (CAIC; Bozdogan, 1987) which is the ratio between the hypothesized model and a saturated model. The CAIC should be less than one as an indicator for model parsimony (Byrne, 2010). The measurement model shows acceptable fit; see Table III.

Table 3: Confirmatory factor analysis, composite reliability and cronbachs alpha

Factor indicators	Standardized loadings	T-value (All significant p.<.01)	C.R	Alpha
<i>Adhocracy role</i>			.846	.835
ROLE 1	.782	12.323		
ROLE 2	.634	10.059		
ROLE 3	.824	12.585		
ROLE 4	.737	11.738		
ROLE 5	.619	a		
<i>Compete role</i>			.841	.837
ROLE 6	.770	14.210		
ROLE 7	.707	13.270		
ROLE 8	.807	14.975		
ROLE 9	.593	10.919		
ROLE 10	.720	a		
<i>Control role</i>			.739	.703
ROLE 11	.465	8.069		
ROLE 12	.759	11.205		
ROLE 13	.675	9.508		
ROLE 14	.441	7.697		
ROLE 15	.720	a		
<i>Collaborate role</i>			.812	.805
ROLE 16	.577	9.025		
ROLE 17	.675	10.072		
ROLE 18	.752	10.597		
ROLE 19	-.732	12.551		
ROLE 20	.606	a		
<i>BD</i>			.851	.849
BD 1	.829	a		

BD 2	.929	18.929		
BD 3	.649	13.961		
BD 4	.831	10.470		
<i>Perceived Performance</i>			.765	.742
PPERF1	.478	a		
PPERF2	.714	9.511		
PPERF3	.836	7.233		
<i>ERP integration</i>				
ERP1	.928	a	.747	.719
ERP2	.607	7.539		

χ^2 to degrees of freedom: 1.992 RMSEA: .049, SRMR: .052, IFI: .927, TLI: .913, CFI: .926, CAIC: .428(1308.365/3049.901 saturated model)

"a" indicates a loading fixed to 1

To assess construct validity, we evaluate the factors' convergent validity, discriminant validity and construct reliability. Convergent validity is established by assessing the fitted residual matrix and the standardized coefficients of factor loadings (Fullerton and Wempe, 2009). Four residuals in the fitted matrix exceeds the threshold of 2.58 (Jöreskog and Sörbom, 1988) with the largest difference .72. However, as the SRMR is within the acceptable threshold (Schmermelleh-Engel *et al.*, 2003; see Table III), we decided not to trim the measurement model²⁴. All standardized factor loadings are significant at $p < .05$ as indicated in Table III. Discriminant validity is established by comparing factor correlations with their squared average variance extracted (AVE; Fornell and Larcker, 1981), where the squared AVE of the factors should be greater than their correlation with other factors. As reported in the diagonal in Table IV, the squared AVEs of individual factors are greater than all factor correlations. In addition, as indicated in Table III,

²⁴ One modification indice was greater than 10 suggesting a correlation between the residuals of items 2 and 3 of the adhocracy role factor. Byrne (2010) describes that a correlation between residuals in a measurement model should be performed only when it has substantial meaning. Both items represent a strategic orientation. Therefore, we correlate the residuals of items 2 and 3 of the adhocracy role.

the composite reliabilities (CRs) are greater than the .7 threshold (Hair *et al.*, 2014).

Table 4: Variable correlations and squared average variance extracted

	Perceived perf.	Compete role	Adhocracy role	Control role	Collaborate role	BD	ERP integration	ROIC 2016
Perceived perf.	.724							
Compete role	.089	.719						
Adhocracy role	.045	.681**	.726					
Control role	-.029	.380**	.369**	.609				
Collaborate role	.355**	.454**	.403**	.291**	.683			
BD	.485**	.274**	.243**	.193**	.346**	.769		
ERP integration	.284**	.368**	.276**	.250**	.322**	.446**	.777	
ROIC 2016	-.008	.063	.019	-.020	.016	.253**	.013	n/a
FTE	-.085	.222**	.240**	.169*	.003	.027	.195**	-.349**

**indicates a $p < .01$, *indicates a $p < .05$ Squared AVE at the diagonal

The main latent variables in this research represent characteristics of different finance function roles, BD and perceived finance function performance. The variables representing the roles of the finance function might be performed by more than one individual, and BD and perceived finance function performance are unit-level (the finance function) variables. We reason that the CFO is most likely to have a comprehensive understanding of these elements. However, surveying the CFO on the roles of the finance function, BD and perceived finance function performance might foster common method bias (Podsakoff *et al.*, 2003). Therefore, it is important to assess interrater-item agreement for the items representing the four finance function roles, BD and perceived finance function performance. We use the COO responses from the 107 companies in which the CFO and the COO responded to the survey²⁵ and use the ADI as suggested by Burke *et al.* (1999). The ADI is determined by evaluating to what extent the individual factor item rating

²⁵ We did not obtain responses to the ERP and strategy items from the COOs.

differs from the mean of the factor and then summing the absolute difference and dividing the sum with the number of deviations (Burke *et al.*, 1999). An ADI of 1.714 indicates acceptable interrater-item agreement for a 7-point Likert scale (Burke and Dunlap, 2002). The ADIs of the factors range between 0.82 (perceived performance) and 1.56 (the compete role) thus indicating acceptable interrater-item agreement. We also address common method bias *ex ante* by ensuring respondent anonymity and by randomly ordering the measures of the exogenous and endogenous variables. *Ex post*, we assess common method bias with a Harman one-factor test (Podsakoff and Organ, 1986). The test does not reveal any great concern for common method bias as a one-factor model explained only 24.64 percent of the variance in the data.

Last, we test for linearity between the exogenous and endogenous variables. All relations are linear with F-values ranging between 2.0640 and 93.799, and R^2 s ranging from .020 to .188. Furthermore, the measurement model does not indicate multicollinearity issues as none of the variation inflation factors are above 1.78 and all tolerance statistics are greater than .58.

In the following, we describe the approach that we use to test complementarity.

8.3.5 *Testing for complementarity*

A key tenet of complementary theory is that the return from jointly using, in our case, finance function roles is greater than the sum of the returns obtained from finance function roles in isolation. Thus, to test for complementarity, a test that compares the additive effects with the complementarity among finance function roles is necessary (Ichniokowski *et al.*, 1997; Whittington *et al.*, 1999; Tanriverdi and Venkatraman, 2005). Ennen and Richter (2010) distinguish between two approaches of testing for complementarity: the interaction approach and the system

approach. The interaction approach models complementarity with pairs of interactions and their main effects in a regression model. The interaction approach is problematic for this study for two reasons. 1) The main variables in regression models used to test the interaction approach are typically heavily correlated, and heavily correlated with the interaction term. When the main variables and their pair-wise interaction terms are heavily correlated, estimates obtained from the regression model reflect only the marginal or partial effects of an exogenous variable on an endogenous variable, given the other exogenous variable (Tanriverdi and Ventakraman, 2005), and not the inherent effect of one exogenous variable on the endogenous variable. Our main variables (finance function roles) are significantly correlated as indicated in Table IV and significantly correlated with their interaction terms, r ranging from .309 to .945²⁶. Therefore, the interaction approach is unsuitable for comparing additive effects with the complementary effects of finance function roles. 2) Our research is about the complementarity of multiple finance function roles. Using the interaction approach, we might then overlook that the expected complementarity between two finance function roles can be because of a third role (Ennen and Richter, 2010).

The system approach focusses on complementarity among a larger set of variables. Gerdin and Greve (2004) suggest profile deviation analyses in order to test complementarity using the system approach. Profile deviation analyses involve segmenting data according to a criterion variable and then finding the ideal state within these segments. As the next step, Euclidian and city-block distances are calculated, and it is hypothesized that deviations from the ideal state are negatively related to a given endogenous variable. However, the city-block distances capture only additive effects, and it is unclear what is exactly captured by the Euclidian

²⁶ This test was performed in SPSS.

distance in terms of testing complementarity effects. Another method for testing complementarity when applying the system approach is to use a categorical variable that captures whether an organizational component is in place or not and then test coefficient estimate differences with respect to the relation between an exogenous variable and an endogenous variable (Ennen and Richter, 2010). However, this method captures only the effects of the exogenous variable on the endogenous variable given the categorical variable, and not the effects of the categorical variable on the endogenous variable given the exogenous variable. Therefore, this method provides little evidence of complementarity. The last method for testing complementarity using the system approach is to apply higher-order interactions in a regression model. However, this method increases correlations between individual variables and their multiplicative interactions leading to interpretational challenges of the regression model results (Tanriverdi and Venkatram, 2005).

In sum, the tests described are not appropriate for testing H1 and H2. Tanriverdi and Venkatram (2005) used a two-model approach to test for complementarity: A first-order factor model that captured the sub-additive effects of their exogenous variables on the endogenous variable was compared with a second-order factor model that accounted for the multilateral interactions and covariance among the exogenous variables. A second-order factor is an entity that is reflected by its first-order factors functioning as its indicators (Williams *et al.*, 2004) and is the main source of covariance among first-order factors (Rindskopf and Rose, 1988). Utilizing Tanriverdi and Venkatram's (2005) approach enables us to compare the isolated additive effects of finance function roles on finance function capability (the first-order factor model) with the complementarity effects among finance function roles on finance function capability (the second-order factor model), and

we avoid the interpretational challenges of regression models due to multicollinearity. We are thus able to determine whether the complementary effects among finance function roles outweigh their isolated additive effects and whether some of the finance function roles are related to finance function capability in isolation. In other words, using Tanriverdi and Venkatraman's (2005) approach, we are able to test H1 and H2.

8.3.6 Assessment of the second-order measurement model

In order to assess the existence of a second-order model and to ensure its multidimensionality, construct and convergent validity, we compare a measurement model where the first-order factors representing the finance function roles are correlated with a model where the first-order factors load on a second-order factor (Tanriverdi and Ventakraman, 2005)²⁷. We use the target coefficient statistic (T) which is the ratio of the chi-square of the first-order model to the chi-square of the second-order model (Marsh and Hocevar, 1985). The T has an upper value of 1, and support for the existence of a second-order model increases the more T approaches unity (Tanriverdi and Ventakraman, 2005). The chi-square of the first-order model is 386, and the chi-square of the second-order model is 387.3 resulting in a T of .99. Thus, the second-order model accounts for 99 percent of the relations among the first-order factors indicating the existence of the second-order model. Furthermore, we assess the second-order loadings; all loadings are significant at a $p < .01$. These results support the multidimensionality, convergent and discriminant validity and the existence of the second-order complementarity factor (Tanriverdi and Ventakraman, 2005; Mishra and Shah, 2009); see Table V

²⁷ Similar to Mishra and Shah (2009) and Tanriverdi and Venkatraman (2005), we include only the factors we expect to be complementary in this test.

which also includes fit indices of the first-order factor model and the second-order factor model.

Table 5: Panel A: Fit indices for the first-order measurement model and the second-order measurement model

Fit indices	First order measurement model	Second order measurement model
X2	381.669	382.971
Degrees of freedom	159	161
X2 to degrees of freedom	2.4	2.379
IFI	.929	.929
TLI	.914	.916
CFI	.928	.929
RMSEA	.059	.058
SRMR	.056	.057
CAIC (default model to saturated model)	.502	.493
Target statistic	.99	

Panel B: loadings on complementary factor

Relationships			Standardized coefficient	T-values (all significant p <.01)
Adhocracy role	<=	Complementarity factor	.791	a*
Compete role	<=	Complementarity factor	.836	7.750
Control role	<=	Complementarity factor	.493	6.401
Collaborate role	<=	Complementarity factor	.556	6.431

* Indicates a loading fixed to 1

8.4 Empirical results

8.4.1 Test of hypotheses

As we described in section 2.5, we constructed two competing hypotheses in order to test whether the four finance function roles are complementary and whether the four roles have additive relations with internal customer understanding. Figure 4 shows a graphical representation of H1 which we label the complementarity model.

The directions of the structural parameters in Figure 4 are from the second-order to the four first-order factors indicating that the second-order factor captures the four finance function roles' covariance and multilateral interactions. To test H1 (the strong form), we relate the second-order factor to BD. Figure 5 depicts a graphical representation of H2 which we label the additive model. It shows that the second-order complementarity factor is removed. Instead, the four finance function roles are modeled as first-order factors with pair-wise covariance, and the four roles are additively related to BD. Furthermore, the FTE variable is not included in the additive model. In Figure 4, the structural parameter from the complementarity factor to BD is statistically significant ($p < .01$, std. $\beta = .430$); H1 (the strong form) is supported. In Figure 5, only the structural parameter from the collaborate role to BD ($p < .01$, std. $\beta = .258$) is significant. Thus, H2 (the weak form) is not supported²⁸. Therefore, we use the complementarity model for evaluating hypotheses 3, 4 and 5. In H3, we contended that the simultaneous use and complementarity of all four finance function roles were related to the number of FTEs employed in the finance function. The result is positive and statistically significant ($p < .01$, std. $\beta = .230$) indicating the simultaneous use and complementarity of all four roles increase the number of FTEs employed. Regarding H4, we predicted that a greater BD was positively related to perceived finance function performance. As indicated in Figure 4 (see also Table VI) and consistent with our prediction, the relation between BD and perceived performance is positive and statistically significant (std. $\beta = .404$, $p < .01$). Furthermore, we predicted that BD was positively related to financial performance (H5). The result

²⁸ Fit indices of the complementarity and additive model without the FTE variable. Complementarity model: χ^2 : 700.790, degrees of freedom: 339, χ^2 to degrees of freedom: 2.067, IFI: .919, TLI: .909, CFI: .919, RMSEA: .051, SRMR: .063, CAIC: .041. Additive model: χ^2 : 689.979, degrees of freedom: 334, χ^2 to degrees of freedom: 2.066, IFI: .921, TLI: .909, CFI: .920, RMSEA: .051, SRMR: .058, CAIC: .041.

is consistent with the prediction as the relation is positive and statistically significant (std. $\beta = .306$, $p < .01$); see Figure 4 and Table VI.

Figure 4: Complementarity model

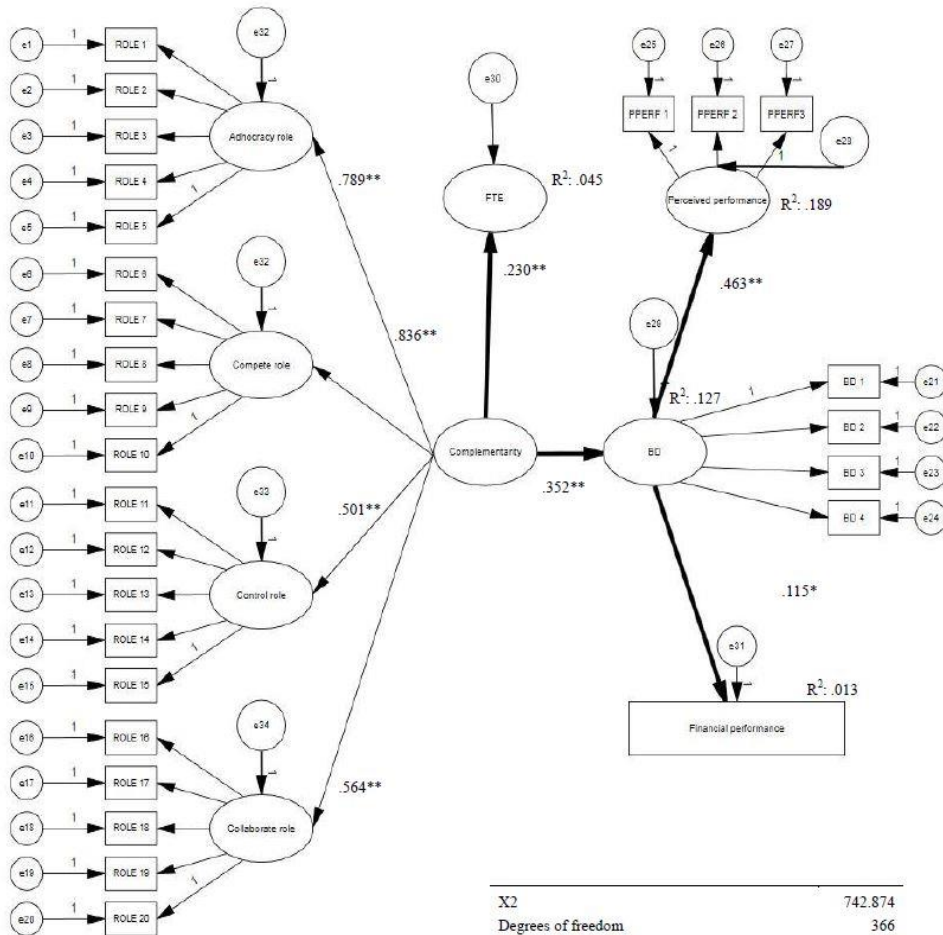

Notes: **p < .01, *p < .05

A bold arrow indicates a significant relationship from an exogenous to an endogenous variable.

Loadings and structural parameters shown are standardized

X2	742.874
Degrees of freedom	366
X2 to degrees of freedom	2.030
IFI	.917
TLI	.907
CFI	.917
RMSEA	.50
SRMR	.064
CAIC (default model to saturated model)	.40

Figure 5: Additive model

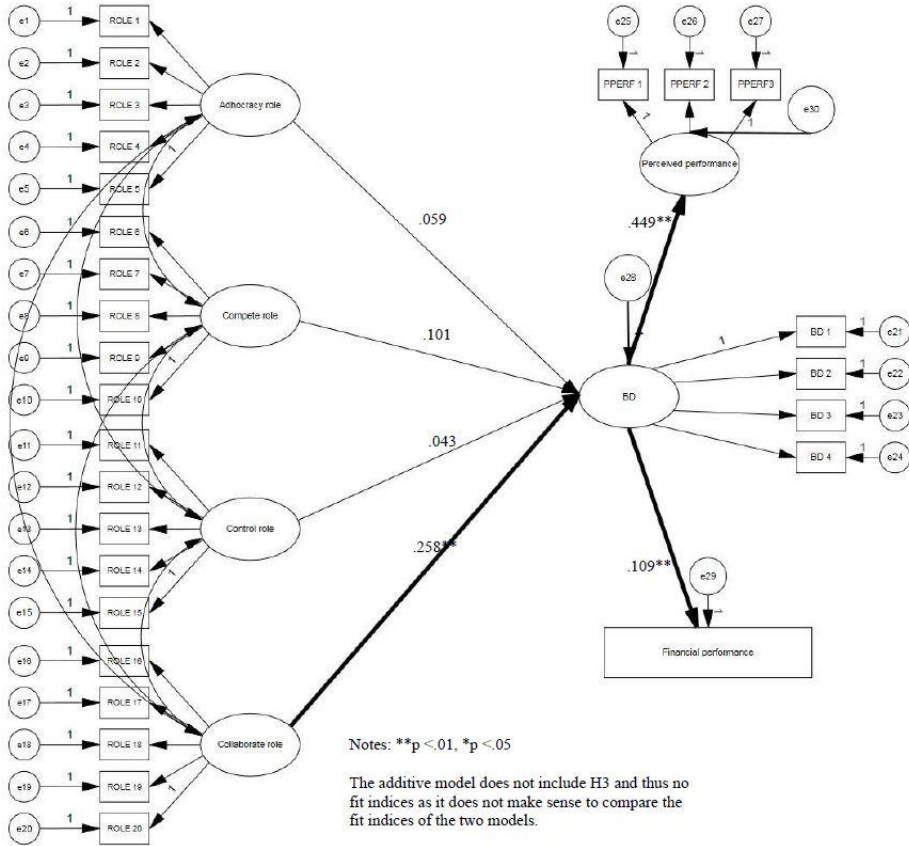

Notes: **p < .01, *p < .05

The additive model does not include H3 and thus no fit indices as it does not make sense to compare the fit indices of the two models.

A bold arrow indicates a significant relationship from an exogenous to an endogenous variable.

Loadings and structural parameters shown are standardized.

Next, we add the control variables described in section 3.2; see Table VII. Although the relations between CFO or not and BD, CFO or not and FTE, tenure and all endogenous variables, strategy and financial performance, and environmental uncertainty and FTE are statistically significant, the statistical inferences from the main model remain similar indicating that the main model is robust.

Table 6: Empirical results

Panel A: Test of H2			Standardized coefficient
<i>Independent variable</i>		<i>Dependent variable</i>	
The adhocracy role	==>	BD	.051
The compete role	==>	BD	.109
The control role	==>	BD	.064
The collaborate role	==>	BD	.236**
Panel B: Test of H1			
Complementarity	==>	BD	.352**
Panel C: Test of H3			
Complementarity	==>	FTE	.230**
Panel D: Test of H4 and H5			
BD	==>	Perceived performance	.463**
BD	==>	Financial performance	.115*

** Indicates a $p < .01$, * indicates a $p < .05$

Table 7: Empirical results with control variables

<i>Independent variable</i>	<i>Dependent variables</i>			
	FTE	BD	Perceived performance	Financial performance
Complementarity	.145**	.413**		
BD			.383**	.120*
<i>Control variables</i>				
CFO or not	.119*	-.191**	-.092	-.081
Tenure	-.103*	.125**	.185**	.006
Strategy	-.097	-.018	-.083	-.137*
Size	-.078	.073	.028	-.017

Environmental uncertainty	.232**	.030	-.099	-.029
ERP integration			.086	

** indicates p <.01, * indicates p <.05

8.5 Discussion and conclusion

Large parts of the literature on finance function roles recognize that the set of roles is increasing and suggest that it is increasing as a function of, for example, organizational changes, environmental uncertainty and myths about benefits stemming from a larger role set. Only a few studies have examined the possible complementarity among finance function roles. Maas and Matejka (2009) used a reductionist approach to test for complementarity among two contrasting controller responsibilities. Furthermore, Maas and Matejka (2009) and Chang *et al.* (2014) did not compare additive effects with the complementary effects which is necessary to provide evidence of complementarity (Tanriverdi and Venkatram, 2005). In this study, we draw upon holistic method testing for complementarity (Ennen and Richter, 2011) and a paradoxical perspective (Schad *et al.*, 2016) on finance function roles. The combination of the complementary and paradoxical perspectives suggests that the use and integration of all four roles enable the roles to inform one another and lead to an increased understanding of the causes and effects and of the organizational whole (Chreim, 2005; Cao *et al.*, 2009; Gerbert *et al.*, 2010). We use SEM on a sample of 408 companies in the services and manufacturing sectors to empirically test our hypotheses.

This study informs the literature on the roles of finance functions in four main ways. We find that the four finance function roles are complementary and that the complementarity enables a greater behavioral differentiation. Only the collaborate role is positively associated with a greater understanding of behavior. As an illustrative example of our findings, consider a finance function which only

emphasizes the control role and the compete role. Then the possible benefits stemming from emphasizing the adhocracy role might be reduced by a too narrow focus on control and cost reductions. On the contrary, if a finance function overemphasizes the adhocracy role, then benefits from the adhocracy role might not occur if the financial boundaries of the organization are not properly delineated by the control role. Furthermore, controlling becomes more cumbersome if the finance function lacks business understanding because (all things equal) the finance function has less understanding of what and when to control.

This study also shows that a greater behavioral differentiation leads to a greater perceived performance of the finance function. This finding suggests that a greater behavioral differentiation enables finance function employees to be more effective because they understand what roles to perform, and when and how to perform them. Furthermore, greater behavioral differentiation reduces role ambiguity and enables the finance function employees to overcome mixed signals in the demand for their work efforts. Last, we find that behavioral differentiation is positively related to return on invested capital, because a greater understanding of internal customer demands increases the likelihood of finance function services and information are used for decision-making, and it reduces the costs and waste of finance function employees providing obsolete information to other functions in companies.

We also contended that the simultaneous use and complementarity of all four finance function roles were related to the number of FTEs in the finance function. We found a positive significant relationship indicating that finance functions emphasizing all roles employ more FTEs. However, there does not appear to be a trade-off between emphasizing all roles simultaneously and emphasizing some of the finance function roles because the complementarity among all four roles is related to an increase in behavioral differentiation which, in turn, is related to an

increase in financial performance. Thus, although the simultaneous emphasis of all four roles increases the number FTEs employed, this additional cost appears to be offset by the increase in behavioral differentiation. The increased behavioral differentiation caused by the simultaneous use and complementarity among all four roles of finance functions seem to be a competitive advantage for the organizations.

Methodologically, we contribute to the literature by using a second-order model technique in order to find evidence of complementarity among finance function roles. This technique is new to this body of literature, and it overcomes many of the struggles of other techniques testing for complementarity. The second methodological contribution of this paper is that we construct finance function roles based on *ex ante* guidance using the CVF (Cameron *et al.*, 2014). The CVF enables us to develop finance function roles from a paradoxical perspective. Furthermore, our research brings a more granulated understanding of finance function roles as we identify two roles rarely measured in the literature, the control role and the collaborate role. In other words, we identify four roles compared with the two-role taxonomy used in much of the previous research (Granlund and Lukka, 1998; Hartmann and Mass, 2011). In addition, we applied a dyadic approach (Schäfer, 2007) as we collected responses from CFOs and COOs to items measuring the main exogenous and endogenous variables. We used the responses from COOs and CFOs to assess the ADI (Burke *et al.*, 1999) of the main variables, and the results were more than acceptable.

This study also provides important evidence for decision-makers. First, although the simultaneous use of and complementarity between all four finance function roles increases the number of FTEs in finance functions, the benefits from emphasizing all roles outweigh these costs. This means that if decision-makers in organizations currently emphasizing a limited number of roles are seeking to grasp

the benefits from emphasizing all four finance function roles, they should not hesitate to develop the additional roles although there is a relative increase in the costs incurred by the finance function. Second, the four roles of finance functions might be easy to replicate. However, decision-makers should understand that the complementarity increases behavioral differentiation which ultimately increases the organization's financial performance. Thus, understanding the complementarity among finance function roles might contribute to a competitive advantage for the organization.

8.6 Limitations and future studies

The common challenges confronting a cross-sectional study are that it does not allow for causal inferences and might be affected by measurement errors. Furthermore, we might have a common method bias problem using the same respondents to indicate exogenous and endogenous variables. The severity of this problem increases when the endogenous variable is perceived performance (Grabner and Speckbacher, 2016). However, we addressed this problem *ex ante* by randomizing the ordering of exogenous and endogenous variables and *ex post* by performing the Harmann one-factor test, and common method bias did not appear to be a big issue. Furthermore, we obtained responses from chief financial officers and chief operating officers and found that interrater-item agreement was within the threshold. We found that the simultaneous use of all four finance function roles showed complementary effects on behavioral differentiation and that behavioral differentiation positively affected the perceived performance of the finance function and the financial performance of the firm. Future studies can shed light on how the increased set of finance function roles is perceived by other functions in the firm. For example, one could imagine that other functions would be hostile

toward the increased set of roles as they might fear that the finance function is expanding its roles to their function's turf.

8.7 Appendix 1

Appendix 1: Table 1:

Survey items

Adhocracy role

Please indicate the frequency of which the finance function perform the following activities

1: never, 2: very rarely, 3: rarely, 4: occasionally, 5: frequently, 6: very frequently, 7: almost always

ROLE 1	Provides advice on strategic matters to operations
ROLE 2	Develops and evaluates investment opportunities for the business
ROLE 3	Helps to set strategic directions and imperatives for the business
ROLE 4	Provides advice concerning growth and future potentials for the business
ROLE 5	Initiates strategic changes

Compete role

Please indicate the frequency of which the finance function perform the following activities

1: never, 2: very rarely, 3: rarely, 4: occasionally, 5: frequently, 6: very frequently, 7: almost always

ROLE 6	Develops cost-savings plans for the business
ROLE 7	Advices other functions with respect to reaching financial and non-financial goals
ROLE 8	Develops profit increasing plans for the firm
ROLE 9	Helps other functions finish projects
ROLE 10	Motivates other functions in the firm to reach their objectives

Control role

Please indicate the frequency of which the finance function perform the following activities

1: never, 2: very rarely, 3: rarely, 4: occasionally, 5: frequently, 6: very frequently, 7: almost always

ROLE 11	Statutory tasks such as monthly close
ROLE 12	Variance analysis of cost and revenue incurred in other functions
ROLE 13	Monitors performance of other functions
ROLE 14	Administrates the firm's reporting system
ROLE 15	Prepares and implements budgets in other functions

Collaborate Role

Please indicate the frequency of which the finance function perform the following activities

1: never, 2: very rarely, 3: rarely, 4: occasionally, 5: frequently, 6: very frequently, 7: almost always

ROLE 16	Establishes common objectives and values when communicating with other functions in the firm
ROLE 17	Exhibits leadership towards other functions in the firm
ROLE 18	Aligns finance and operational systems with the business
ROLE 19	Collaborates with other functions and establishes consensus among them
ROLE 20	Actively listens to and legitimizes other employees' suggestions that affects the firm's financials

Behavioral differentiation

Please indicate the degree of which you agree with respect to the following statements

1: totally disagree, 2: disagree 3: partially disagree, 4: neutral, 5: partially agree, 6: agree, 7: strongly agree

BD 1	The conduct of the finance function is in line with organizational expectations
BD 2	The level of activities performed by the finance function conform to organizational expectations
BD 3	The finance function comply with internal customer demand on time
BD 4	The finance function performs activities with great quality

Perceived performance

Please indicate the level of satisfaction with respect to the following statements

1: very dissatisfied, 2: moderately dissatisfied, 3: slightly dissatisfied, 4: neutral, 5: slightly satisfied, 6: moderately satisfied, 7: very satisfied

PPERF 1	The reputation of the finance function in the firm
PPERF 2	The success of the finance function
PPERF 3	Performance of the finance function relative to finance functions in similar firms

ERP integration

Please indicate the degree of which you agree with respect to the following statements

1: totally disagree, 2: disagree 3: partially disagree, 4: neutral, 5: partially agree, 6: agree, 7: strongly agree

ERP 1	We use an IT-system that ensures great quality with respect to information and data input for the finance function
ERP 2	We use an IT-system in the finance function that ensures that we do not receive redundant or information and data that are not necessary

Strategy

Please indicate the description of firms below that fit the most to your firm

PROSPECTOR	These businesses are frequently the first-to-market with new product or service concepts. They do not hesitate to enter new market segments where there appears to be an opportunity. These businesses concentrate on offering products that push performance boundaries. Their proposition is an offer of the most innovative product, whether based on dramatic performance improvement or cost reduction
ANALYZER	These businesses are seldom 'first-in' with new products or services or to enter emerging market segments. However, by carefully monitoring competitors' actions and customers' responses to them, they can be 'early-followers' with a better targeting strategy, increased customer benefits, or lower total costs.
DEFENDER	These businesses attempt to maintain a relatively stable domain by aggressively protecting their product-market position. They rarely are at the forefront of product or service development; instead they focus on producing goods or services as efficiently as possible
REACTOR	These businesses generally focus on increasing share in existing markets by providing products at the best prices. These businesses do not appear to have a consistent product-market orientation. They primarily act to respond to competitive or other market pressures in the short term.

8.8 Literature

Adler, P. S., Borys, B. (1996). Two types of bureaucracy: Enabling or coercive. *Administrative Science Quarterly*. Vol. 41, pp. 61-89.

Ahrens, T., Chapman, C. S. (2000). Occupational identity of management accountants in Britain and Germany. *European Accounting Review*, Vol. 9 No. 4, pp. 477-498.

Ahrens, T., Chapman, C. S. (2004). Accounting for Flexibility and Efficiency: A Field Study of Management Control Systems in a Restaurant Chain.

Contemporary Accounting Research, Vol. 21 No. 2, pp. 271-301.

Adler, P. S., Borys, B. (1996). Two types of bureaucracy: Enabling or coercive. *Administrative Science Quarterly*. Vol. 41, pp. 61-89.

Anderson, D. R. The function of industrial controllership (1944). *The Accounting Review*, Vol. 19, no. 1, pp. 55-65.

Bechtold et al., C., Reimer, M., Schäffer, U. (2014). The Multi-Role Job Profile of Controllers: A Double-Edged Sword. *Working paper presented at the "New Directions in Management Accounting Research"* conference 2014, Brussels, Belgium.

Bentler, P. M. (1990). Comparative fit indexes in structural models. *Psychological Bulletin*, Vol. 107, pp. 238-246.

Bentler, P. M. (1992). On the fit of models to covariances and methodology to the *Bulletin*. *Psychological Bulletin*, Vol. 112, pp. 400-404.

Bollen, K. A. (1989), *Structural equation with latent variables*, New York: Wiley.

Bozdogan, H. (1987). Model selection and Akaike's information criteria (AIC): The general theory and its analytical extensions. *Psychometrika*, Vol. 52, pp. 345-370 .

Browne, M. W., Cudeck, R. (1993). *Alternative ways of assessing model fit*. In: Bollen, K. A. Long, J. S. (Eds.). *Testing Structural Equation Models*. Sage, Newbury Park, California, pp. 136-162.

Burke, M. J., Dunlap, W. P. (2002). Estimating interrater agreement with the average deviation index: A user's guide. *Organizational Research Methods*. Vol.

5, No. 2, pp. 159-172.

Burke, M. K., Finkelstein, L. M., Dusig, M. S. (1999). On average deviation indices for estimating interrater agreement. *Organizational Research Methods*. Vol. 2, pp. 49-68.

Burns, J., Baldvindsdottir, G. (2005). An institutional perspective of accountants' new roles – the interplay of contradictions and praxis. *European Accounting Review*. Vol. 14, No. 4, pp. 725-757.

Byrne, S., Pierce, B. (2007). Towards a More Comprehensive Understanding of the Roles of Controllers, *European Accounting Review*, Vol. 16. no. 3, pp. 469-498.

Byrne, B. M. (2010). *Structural Equation Modeling with AMOS – Basic Concepts, Applications, and Programming*. 2nd edition, Routledge, Taylor & Francis Group. New York.

Caglio, A. (2003). Enterprise Resource Planning Systems and Accountants: towards hybridization? *European Accounting Review*, Vol. 12 No. 1, pp. 123-153.

Cameron, Kim S., Robert E. Quinn., Jeff Degraff & Anjan V. Thakor. (2014). *Competing Values Leadership*. New Horizons in Management, 2nd edition.

Carmeli, A., Halevi, M. Y. (2009). How top management team behavioral integration and behavioral complexity enable organizational ambidexterity: The moderating role of contextual ambidexterity. *The Leadership Quarterly*, Vol. 20, pp. 207-218.

- Cao, Q., Gedajlovic, E., Zhang, H. (2009). Unpacking organizational ambidexterity: Dimensions, contingencies and synergistic effects. *Organization Science*, vol. 20, No. 4, pp. 781-796.
- Chang, H., Ittner, C. D., Paz, M., T. (2014). The multiple roles of the finance organization: Determinants, effectiveness, and the moderating influence of information system integration. *Journal of Management Accounting Research*, vol. 26. No. 2, pp. 1-32
- Chapman, C. S. (1998). Accountants in organizational networks. *Accounting, Organizations and Society*, Vol. 23 No. 8, pp. 737-766.
- Chenhall, R. (2003). Management control systems design within its organizational context: findings from contingency-based research and directions for the future. *Accounting, Organizations and Society*, Vol. 28, pp. 127-168.
- Chreim, S. (2005). The continuity-change duality in narrative texts of organizational identity. *Journal of Management Studies*, Vol. 42, no. 3, pp. 567-593.
- Dedreu, C. K. W. (1991). Productive conflict: The importance of conflict management and conflict issue. *Using conflict in Organizations*. Dedreu, C. K. W., Van de Vliert, E. (Eds.). Sage Publications: London.
- Denis, J., Langle, A., Sergi, V. (2012). Leadership in the plural. *Academy of Management Annals*, Vol. 6, January, pp. 211-283.
- Denison, D. R., Hoijberg, R., Quinn, R. E. (1995). Toward a Theory of Behavioral Complexity in Managerial Leadership, *Organization Science*. Vol. 6, No. 5, pp. 524-540.

Dess, G. G., Robinson jr. R. B. (1984). Measuring organizational performance in the absence of objective measures: The case of the privately-held firm and conglomerate business unit. *Strategic Management Journal*, Vol. 5, No. 3, pp. 265-273.

Donaldson, L. (2001). *The contingency theory of organizations*. Sage Publications: Thousands Oaks, CA.

Drach-Zahavy, A., Freund, A. (2007). Team effectiveness under stress: A structural contingency approach. *Journal of Organizational Behavior*, Vol. 28, No. 4, pp. 423-450.

Ennen, E., Richter, A. (2010). The whole is more than the sum of its parts – or is it? A review of the empirical literature on complementarities in organizations. *Journal of Management*, Vol. 36 No. 1, pp. 207-233.

Eustler, J., Lang, B. (2015). Rating scales in accounting research: The impact of scale points and labels. *Behavioral Research in Accounting*, Vol. 27 No. 2, pp. 35-51.

Floyd, S. W., Wooldridge, B. (1992). Middle management involvement in strategy and its association with strategic type: A research note. *Strategic Management Journal*, vol. 13, pp. 153-167.

Fornell, C., and Larcker, D. F. 1981. Evaluating structural equation models with unobservable variables and measurement error. *Journal of Marketing Research*, vol, 43, pp. 39–50.

Fullerton, R. R., Wempe, W. F. (2009). Lean manufacturing, non-financial performance measures, and financial performance. *International Journal of*

Production Management, Vol. 29 No. 3, pp. 214-240.

Gerdin, J., Greve, J. (2004). Forms of contingency fit in management accounting research – A critical review. *Accounting, Organizations & Society*, Vol. 29 No. 3-4, pp. 303-326

Gibson, C. B. Birkinshaw, J. (2004). The antecedents, consequences, and mediation role of organizational ambidexterity. *Academy of Management Journal*, vol. 47. No. 2, pp. 209-226.

Grabner, I., Moers, F. (2013). Management control as a system or a package? Conceptual and empirical issues. *Accounting, Organizations & Society*, Vol. 38, pp. 407-419.

Grabner, I., Speckbacher, G. (2016). The cost of creativity: A control perspective. *Accounting, Organizations and Society*, vol. 48, pp. 31-42.

Granlund, M., Lukka, L. (1998). Towards increasing business orientation: Finnish controllers in a changing cultural context, *Management Accounting Research*, Vol. 9, pp. 185-211

Hall, M. (2008). The effect of comprehensive performance measurement systems on role clarity, psychological empowerment and managerial performance. *Accounting, Organizations and Society*, Vol. 33, pp. 141-163.

Hair, J., Black, W., Babin, B., Anderson, R. (2014). *Multivariate data analysis* (7th ed.). Pearson Education Limited. Edinburgh, England.

Hansen, S. C., Van der Stede, W. A. (2004). Multiple facets of budgeting: an exploratory analysis. *Management Accounting Research*, vol. 15, pp. 415-439.

- Hartmann, F. G. H., Maas, V. S. (2011). The effects of uncertainty on the roles of controllers and budgets: an exploratory study. *Accounting and Business Research*, Vol. 41 No. 5, pp. 439-458.
- Hawawini, G., Viallet, C. (2011). *Finance For Executives – Managing for Value Creation*. South-Western Cengage Learning: Mason, OH.
- Hedström, P., Swedberg, R. (1996). Rational choice, empirical research and the sociological tradition. *European Sociological Review*, Vol. 12, pp. 127-146.
- Henri, J-F. (2006). Management control systems and strategy: A resource-based perspective. *Accounting, Organizations and Society*, Vol. 31, No. 529-558.
- Hooijberg, R. (1996). A Multidirectional approach toward leadership: An extension of the concept of behavioral complexity. *Human Relations*, vol. 49, No. 4, pp. 917-946.
- Hooijberg, R., Hunt, James. G., Dodge, G. E. (1997). Leadership Complexity and Development of the Leaderplex Model. *Journal of Management*, Vol. 23 No. 3, pp. 375-408.
- Ichniowski, C., Shaw, K., Prennushi, G. (1997). The effects of human resource management practices on productivity: a study of steel finishing lines. *American Economic Review*, Vol. 87 No. 3, pp. 291-313.
- Jun, M., Cai, M. (2010). Examining the relationships between internal service quality and its dimensions, and internal customer satisfaction. *Total Quality Management*, Vol. 21, No. 2, pp. 205-223.
- Jöreskog, K.G., Sorbom, D. (1988), LISREL 7: A Guide to the Program and Applications, SPSS,

Inc., Chicago, IL.

Järvenpää, J. (2007). Making business-partners: A case study on how management accounting culture was changed, *European Accounting Review*, vol. 16, No. 1, pp. 99-142.

Kalliath, T. J., Bluedorn, A. C., Gillespie, D. F. (1999). A confirmatory factor analysis of the competing values instrument. *Educational and Psychological Measurement*, vol. 59, no. 1, pp. 143-158.

Keyes, C. L., Hysom, S. J., Lupo, K. L. (2000). The positive organization: Leadership legitimacy, employee well-being, and the bottom-line. *The Psychologist-Manager Journal*, Vol. 4, No. 2, pp. 143-153.

Kline, R.B. (2005). Principles and practice of structural equation modeling, 2nd edition. New York: The Guildford Press.

Kline, R. B. (2011). *Principles and practice of structural equation modeling*, 3rd edition. New York: The Guildford Press.

Lambert, C. Sponem, S. (2012). Roles, Authority, and Involvement of the Management Accounting Function: A Multiple Case-study Perspective. *European Accounting Review*, Vol. 21 No. 3, pp. 565-589.

Laplume, A. O., Dass, P. (2012). Exploration and exploitation for various stages of firm growth through diversification. Paper presented at the annual meetings of the Academy of Management, Boston.

Lawrence, K. A., Lenk, P., Quinn, R. E. (2009). Behavioral complexity in leadership: The psychometric properties of a new instrument to measure behavioral repertoire. *The Leadership Quarterly*, vol. 20, pp. 87-102.

Lewis, M. W. (2000). Exploring Paradox: Toward a More Comprehensive Guide. *The Academy of Management Review*, Vol. 25 No. 4, pp. 760-776.

- Lind, J. (2001). Control in world class manufacturing – A longitudinal case study. *Management Accounting Research*, vol. 12, pp. 41-74.
- Luft, J. Shields, M. D. (2007). Mapping management accounting. Graphics and guidelines for theory-consistent empirical research. In *Handbook of Management Accounting Research*, Vol. 1, Eds.: Chapman, C. S., Hopwood, A. G., Shields, M. D., pp. 27-95. Oxford: UK.
- Mahlendorf, M. D. (2014). Discussion of the roles of the finance organization: Determinants, effectiveness, and the moderating influence of information system integration, *Journal of Management Accounting Research*, vol. 26, No. 2, pp. 33-42.
- Marsh, H. W. Hocevar, D. (1985). Application of confirmatory factor analysis to the study of self-concept: First- and higher order factor models and their invariance across groups. *Psychological Bulletin*, Vol. 97 No. 3, pp. 562-582.
- Maas, V, S., Matejka, M. (2009). Balancing the Dual Responsibilities of Business Unit Controllers: Field and Survey Evidence, *The Accounting Review*, Vol. 84, No. 4, pp. 1233-1253.
- Misra, A., Shah, R. (2009). In union lies strength: Collaborative competence in new product development and its performance effects. *Journal of Operations Management*, Vol. 27, pp. 324-338.
- Mouritsen, J. (1996). Five aspects of accounting department's work, *Management Accounting Research*, Vol. 7, pp. 283-303.
- Mouritsen, J. (2004). Økonomifunktionens rolle og strategi. *Håndbog i Økonomistyring*, 1st edition. *Revifora*.
- Nicotera, A. M. (1995). *Conflict and organizations*. State University of New York Press: Albany.

- O'Reilly, C., Tushman, M. L. (2008). Ambidexterity as a dynamic capability: Resolving the innovator's dilemma. *Research in Organizational Behavior*, vol. 28, pp. 185-206.
- O'Reilly, C., Tushman, M. L. (2013) Organizational ambidexterity: past, present, and future. *The Academy of Management perspectives*, vol. 27, No. 4, pp. 324-338.
- Patel, P. C., Messersmith, J. G., Lepak, D. P. (2013). Walking the tightrope: An assessment of the relationship between high-performance work systems and organizational ambidexterity. *Academy of Management Journal*, vol. 56 No. 5, pp. 1420-1442.
- Pierce, B., O'Dea, T. (2003). Management accounting information and the needs of managers' perceptions of managers and accountants compared. *The British Accounting Review*, vol. 35, pp. 257-290.
- Poole, M. S., Van de Ven, A. H. (1989). Using paradox to build management organization theories. *The Academy of Management Review*, Vol. 14, No. 4, pp. 562-578.
- Podsakoff, P.M., Organ, D.W. (1986). Self-reports in organizational research: problems and prospects. *Journal of Management*, Vol. 12 No.4, pp. 531-544.
- Podsakoff, P. M., Mackensie, S. B., Lee, J. Y., Podsakoff, N. P. (2003). Common method bias in behavioral research: a critical review of the literature and recommended remedies. *Journal of Applied Psychology*, vol. 88, no. 5, pp. 879-903.
- Quinn, R, E., Rohrbaugh, J. (1981). A Competing Values Approach to

- Organizational Effectiveness, *Public Productivity Review*. Vol. 5, No. 2, pp. 122-140.
- Rindskopf, D. and Rose, T. (1988). Some theory and applications of confirmatory second-order factor analysis. *Multivariate Behavioral Research*, Vol. 23 No. 1, pp. 51-67.
- Sathe, V. (1983). The Controller's Role in Management, *Organizational Dynamics*, Winter, pp. 31-48.
- Schad, J., Lewis, M. W., Raisch, S., Smith, W. (2016). Paradox Research in Management Science: Looking back to move forward. *The Academy of Management Annals*, April, pp. 1-60.
- Schermelleh-Engel, K., Moosbrugger, H., Muller, H. (2003). Evaluating the fit of structural equation models: tests of significance and descriptive goodness-of-fit measures. *Methods of Psychological Research Online*, Vol. 8 No. 2, pp. 23-74.
- Schmitt, A., Raisch, S. (2013). Corporate turnarounds: The duality of retrenchment and recovery. *Journal of Management Studies*, Vol. 50 No. 7, pp. 1216–1244.
- Schäffer, U. (2007). *Management Accounting & Control Scales Handbook*. Deutscher Universitäts-Verlag: Wiesbaden.
- Simon, H. A., H. Guetzkow, G. Kozmetsky, Tyndall. (1954). *Centralization Versus Decentralization in Organizing the Controller's Department*. The Controllership Foundation: New York.
- Smith, W. K., Lewis, M. W. (2011). Toward a theory of paradox: A dynamic equilibrium model of organizing. *The Academy of Management Review*, Vol. 36 No. 2, pp. 381-403.
- Slater, S. F., Olson, E. M. (2000). Strategy type and performance: the influence of sales force management. *Strategic Management Journal*, Vol. 21, pp. 813-829.
- Sorensen, J. (2009). Management Accountants in the United States: Practitioner and Academic Views of Recent Developments. *Handbook of Management*

- Accounting Research*, vol. 3. Chapman, C. S., Hopwood, A. G., Shields, M. D (Eds). Elsevier: U.K.
- Tanriverdi, H., Venkatraman, N. (2005). Knowledge relatedness and the performance of multibusiness firms. *Strategic Management Journal*, Vol. 26 No. 2, pp. 97-119.
- Tucker, L. R., Lewis, C. (1973). A reliability coefficient for maximum likelihood factor analysis. *Psychometrika*, Vol. 38, pp. 1-10.
- Tubre, T. C., Collins, J. M. (2000). Jackson and Schuler (1985) revisited: A meta-analysis of the relationships between role ambiguity, role conflict and job performance. *Journal of Management*, Vol. 26, pp. 155-169.
- Ylinen, M., Gullkvist, B. (2014). The effects of organic and mechanistic control in exploratory and exploitative innovations. *Management Accounting Research*, Vol. 25, pp. 93-112.
- Widener, S. K. (2007). An empirical analysis of the levers of control framework. *Accounting, Organizations and Society*, vol. 32, pp. 757-788.
- Williams, L. J., Gavin, M. B. and Hartman, N. S. (2004). *Structural Equation modeling methods in strategy research: Applications and issue*. In Research Methodology in Strategy and Management, 1. Ketchen, D. J. and Berg, D. D (Eds). Elsevier/JAI press, Connecticut, pp. 33-65.
- Weber, J. (2011). The development of controller tasks: explaining the nature of controllership and its changes. *Journal of Management Control*, Vol. 22 No. 25, pp. 25-45.
- Weissenberger, B. E., Angelkort, H. (2011). Integration of financial management accounting systems: The mediating influence of a consistent financial language

on controllership effectiveness. *Management Accounting Research*, vol. 22, pp. 160-180.

Whittington, R., Pettigrew, A., Peck, S., Fenton, E., Conyon, M. (1999). Change and complementarities in the new competitive landscape: A European panel study, 1992-1996. *Organization Science*, Vol. 10 No. 5, pp. 583-600.

9. Paper 3: Lean and management accountants: Survey evidence of the roles of finance functions

Henrik Nielsen^a and Thomas Borup Kristensen^a

^a*Department of Business and Management, Aalborg University*

Keywords: Lean operation, the roles of finance functions, structural equation modeling.

Abstract

Purpose: This paper studies the relations between Lean operations, Lean principles in finance functions, and the roles of finance functions.

Design/Methodology/Approach: The paper uses structural equation modeling to analyze data from 408 different firms in the Danish production and services sectors. A dyadic approach is applied, as a sub-sample of 107 chief operating officers in the responding firms is used to investigate the construct validity, reliability, and average deviation index of the instrument measuring the roles of finance functions.

Findings: The paper finds that Lean operation firms emphasize four different yet interdependent roles of finance functions. The paper also finds that Lean operation leads to finance functions in Lean operation firms adapting Lean principles.

Research limitations/implications: This paper characterizes Lean operation firms as contextually ambidextrous in order to predict relations between Lean operation and roles of finance functions. The paper expands prior case study findings on the roles of finance functions in Lean operation firms, and the findings of the paper underline that finance functions continue to play an important role in Lean operation firms.

Practical implications: Decision makers in Lean operation firms should not be hesitant with respect to integrating finance function workers in the Lean operation. Furthermore, decision makers should understand that a balanced emphasis of the roles of finance functions is necessary in order to avoid overemphasizing exploitation at the expense of exploration or vice versa.

Originality/value: This is the first paper to provide large-scale evidence of the roles of finance functions in Lean operation firms and to show that Lean principles from operations diffuse to the finance function. Furthermore, the paper introduces a new instrument for measuring finance function roles, based on the competing values framework.

9.1. Introduction

Research on the roles of finance functions has a relatively long history in management accounting research. It dates back to the 1940s (Anderson, 1944), although it gained momentum in the 1990s (e.g., Ahrens, 1997; Chapman, 1998; Granlund & Lukka, 1998; Mouritsen, 1996). A number of studies have explored the antecedents of finance function roles. For example, Caglio (2003), Granlund

and Malmi (2002), and Jarvenpää (2007) studied how the implementation of enterprise resource planning systems affected finance function roles; Ahrens and Chapman (2000) studied differences in occupational identity and the roles of finance function workers in relation to the German and British nationalities; Granlund and Taipaleenmäki (2005) studied the roles of a finance function in a new economy firm; and Byrne and Pierce (2007) established comprehensive evidence of the antecedents of roles in a study of 16 companies. Based on the evidence presented in these papers, it is fair to say that finance functions workers spend more time on business-integrated roles, organizational design, and system development in comparison with, for example, the 1980s (Big Eight White Paper, 1988). A specific firm characteristic that seems to influence the roles of finance functions is worth noting. In a firm implementing the process method of production, focusing on customer value and cost reductions, Burns and Baldvindsdottir (2005) found that controlling responsibility was transferred from finance function workers to operations after the implementation. However, new roles emerged and finance function workers were more involved in operations than they were prior to the implementation. This pattern is echoed in Lind's (2001) study of a firm implementing world class manufacturing²⁹ and to some extent in Tillema and van der Steen's (2015) study of two companies implementing Lean manufacturing. As this paper focuses on the roles of finance functions in Lean firms, it seeks to extend their findings.

In recent years, Lean has been widely adopted in production (Tillema & van der Steen, 2015) and service firms (Maleyeff, 2006). The implementation of a Lean

²⁹ Burns and Baldvindsdottir's (2005) descriptions of the program implemented in their case company resembles Lean, and we therefore include their findings. Furthermore, we consider world class manufacturing and Lean to be very similar and therefore include Lind's (2001) and Jayazeri and Hopper's (1999) studies in this paper.

operation³⁰ affects the entire firm (Liker, 2004) as Lean is an enterprise-wide system where structures are aligned and people at all levels are involved and committed to the implementation (Emiliani *et al.*, 2003; Furlan *et al.*, 2011; Netland *et al.*, 2015). In the management accounting literature, research has focused on how Lean affects management accounting systems, and recent evidence shows that firms adapt their management accounting systems to be congruent with Lean implementation (Kennedy & Widener, 2008; Fullerton *et al.*, 2013; 2014). Except for a few case studies, there is no research on finance functions roles in Lean operation firms.

Although highlighting the importance of cost accounting, Cooper (1996) raised a concern for finance function workers in Lean operation firms, as he predicted that most of their responsibilities would be transferred to employees in operational areas. Further, he claimed that only finance function workers who developed skills in change management, system design, and strategy would survive. This concern is echoed in more recent literature (Maskell *et al.*, 2012). However, Kapanowski (2017) states that the finance function continues to encompass important roles in Lean firms with respect to controlling and monitoring performance, analyzing the financial impact of Lean results, and developing the Lean implementation.

We view Lean operation firms through the lens of contextual ambidexterity (Gibson & Birkinshaw, 2004). Contextually ambidextrous firms are characterized by having aligned all organizational structures in order for employees to balance simultaneous exploration and exploitation (Raisch *et al.*, 2009). It is predicted that the finance functions are representative of these organizational structures, and we maintain that finance functions play an integral role in Lean operation firms. In

³⁰ We use the term "Lean operation" as our sample includes firms from the manufacturing and services sectors.

order to operationalize finance function roles as representing the organizational structures that enable contextual ambidexterity, we develop four roles based on the competing values framework (CVF) (Cameron *et al.*, 2014), which sheds light on the different but necessary organizational elements that must permeate an ambidextrous organization (Carmeli & Harlevi, 2009). We also predict that finance function roles in Lean operation firms are interdependent because these roles represent organizational structures that must be in place and must be balanced in order for the firm to simultaneously exploit and explore (cf. Cao *et al.*, 2009).

Practices and systems in Lean operation firms are recognized as being tightly coupled (Roberts, 2004). This, we argue, not only requires that practices and systems be adapted to fit the Lean implementation but it also implies that Lean increases the extent to which functions in a Lean operation firm depend on one another for assistance, communication, coordination and compliance with respect to the performance of their respective tasks. It also increases the extent to which successful ideas are shared throughout the firm (Ross, 1974). We predict that Lean diffuses from operations to finance functions in that finance functions in Lean operation firms adopt Lean principles. Further, it is argued that finance functions which employ Lean principles obtain a greater understanding of customer demands and greater flexibility, and we predict that this affects finance function role emphases in Lean operation firms.

Using a sample of 408 firms from the Danish manufacturing and service sectors, we apply structural equation modeling (SEM) to examine the predicted relationships. We contribute to the literature in three main ways. We are the first to provide large-scale survey evidence of finance function roles in Lean operation firms. We find that a Lean operation increases emphasis on four roles; 1) the collaborate role focusing on alignment and cooperation, 2) the adhocracy role

focusing on growth, adaption to the environment and innovation, 3) the compete role focusing on cost-reduction, goal-setting, and productivity, and 4) the control role focusing on consistency, predictability, and monitoring of performance. We also find that the roles of finance functions are interdependent. Altogether, these findings respond to a call made by Fullerton *et al.* (2014), who welcome more research that increases understanding of the interplay between management accounting and Lean. They also respond to Mahlendorf (2014), who welcomes research on interdependencies among finance function roles. Second, we respond to Byrne and Pierce (2007), who call for research on more contemporary finance function roles in other sectors than manufacturing. Third, we use the CVF as theoretical guidance to develop a measurement instrument for finance function roles specifically pertaining to Lean operation firms. We apply a dyadic approach (Schäffer, 2007) as we also use sub-sample of COOs in the firms where the CFO responded in order to verify the construct validity, reliability, and interrater agreement of the instrument.

The remainder of this paper is organized as follows: In Section 2, we go through the literature and develop hypotheses. In Section 3, the sample and methods are presented and, in Section 4, we present the results. Results are discussed and conclusions are presented in Section 5, while Section 6 presents the limitations of this paper.

9.2 Background literature and hypotheses development

There is little empirical evidence pertaining to the roles of finance functions in Lean operation firms in the academic literature. Lind (2001) studied the implementation of world class manufacturing in a Swedish firm and found that finance function employees were involved with operations with respect to perfecting and sharing financial and nonfinancial information with managers, and

they were acting as partners of the managers' daily work. This had been not the case prior to the implementation. Tillema and van der Steen (2015) studied the implementation of Lean manufacturing in decentralized manufacturing units in two firms. Both units had a local finance function. In one of the units, the finance function supported operations with respect to developing non-financial measures and connecting them with financial measures. In the other unit, the local finance function translated non-financial Lean progression to headquarters. In both units, there were tensions with headquarters, as headquarters continued to rely on financial information whereas the local manufacturing units relied on Lean-related non-financial information. The local finance functions tried to alleviate these tensions but were "caught in the middle" between satisfying reporting requirements to headquarters and supporting local Lean development. Kennedy and Widener (2008) studied the implementation of Lean manufacturing in a case firm. They found that a Lean accountant actively led the necessary transformation of the case firm's management control system in order to provide employees the information they needed for Lean related decision-making.

Studying the implementation of world class manufacturing in a case firm, Jazayeri and Hopper (1999) found that most control of performance was transferred from the finance function to operations personnel through the use of an MRP system and the generation and use of quality reports. These reports removed the finance function as an information filter and enabled employees to act as consultants and to play creative roles within teams at strategic and operational levels. However, the finance function continued to provide financial information to managers at higher hierarchical levels. Ezzamel *et al.* (2008) studied the role of accounting in a firm implementing a continuous improvement program. The firm emphasized a linking of accounting metrics with operations in order to secure that accounting metrics

were understood and acted upon by operations employees. A senior accountant who was responsible for strengthening the linkages focused on working closely with operations. This close collaboration made the finance function aware of relevant accounting metrics for operations, and these metrics were ultimately visualized on the shop floor.

Burns and Baldvindsdottir (2005) focused on the implementation of the process way of working, which resembles Lean operation in the sense that the primary focus of the process way of working is on satisfying customer demands and reducing costs. They found that much controlling and budgeting responsibility was transferred from the finance function to operations personnel. However, the finance function took on other roles after the implementation. First, the finance function taught business managers financial accounting in order for them to take on this new responsibility. Second, although it was to a small extent, finance function workers assisted business managers in financial accounting related matters, and they also tweaked management accounting systems to comply more with the needs of business managers. Third, finance function workers advised product stream leaders in strategic matters and risks.

In sum, it appears from these studies that finance functions are involved in performance system design and that they work closely together with operations in Lean firms. In some cases, the control of operative performance in Lean operation firms is transferred to operations personnel, and finance functions still appear to perform financial controlling, although to a lesser extent and primarily as a function of demands from higher hierarchical levels. It is difficult to draw general inferences from these single-firm studies, and some findings are confounding. Thus, to show how management accounting can support firms implementing Lean, a cross-sectional study is needed (Jazayeri & Hopper, 1999). No cross-sectional

study has explored what finance functions do in Lean operation firms, and Cooper's (1996) predictions have consequentially not been studied to determine whether they have held. We rely on the notion of contextual ambidextrous organizations (Gibson & Birkinshaw, 2004) to explore the roles of finance functions in Lean firms. Contextual ambidexterity means that the organization has structures permeating the entire organization that enable its members to simultaneously explore and exploit. The next section describes and connects Lean operation firms with ambidexterity³¹.

9.2.1 Lean operation firms and ambidexterity

March (1991) notes that exploitation is about efficiency, control, and variance reduction, while exploration is about search, discovery, autonomy, and innovation. Overemphasizing exploitation at the expense of exploration causes organizational myopia (Radner, 1975), competency traps (Levitt and March, 1988), and a loss of long-term competitive advantages as a function of changing contingencies; overemphasizing exploration at the expense of exploitation is destructive as the firm neglects to exploit current competencies and potentially leaps from one search failure to another (Levinthal & March, 1993). Thus, March (1991) argued, it is necessary to maintain a proper balance between exploitation and exploration for firms to prosper. Firms that are able to balance exploration and exploitation are conceptualized as ambidextrous organizations (Tushman and O'Reilly, 1996).

³¹ Most literature connecting ambidexterity and Lean uses the term "Toyota Production System." In the next section, we use "Toyota Production System" whenever used by the presented literature. Otherwise we use "Lean operation" throughout the paper to ensure parsimony and coherence. It is justifiable to do so, as Lean rests upon the Toyota Production System (Krafscik, 1988).

Lean firms possess the characteristics of ambidextrous organizations (Adler *et al.*, 2009). An example is Adler's (1999) description of how the Toyota Production System works: workers are expected to follow standardized work, which is the current best way of performing a process. In addition, inventory is assigned a circle on the floor indicating the location and highlighting the acceptable inventory level, and work tools have a specified place at every work station (Brunner *et al.*, 2010). Also, materials follow predefined flows throughout the operation facility, and the kanban system ensures a standardized amount of items flowing between work stations (Emiliani *et al.*, 2003). Thus, the Toyota Production System employs precepts of scientific management relying heavily on standardization (Adler *et al.*, 2009). This standardization is employed for reducing variability in processes in order to ensure consistent output (Liker, 2004) and leads to exploitation. However, finding and setting a standard is an effort pertaining to all organizational members, as employees and management both participate in identifying and setting the ideal (Adler & Borys, 1996). Employees enjoy great flexibility and are encouraged to continuously challenge standards in the pursuit of improvement that is both incremental, *kaizen*, and radical, *kakushin* (Adler *et al.*, 2009) and that can foster exploration.

The Toyota Production System also emphasizes what Brunner *et al.* (2010) characterize as deliberate perturbations. Deliberate perturbations are novel stimuli that disrupt the execution of otherwise standardized processes (Adler *et al.*, 2009). For example, the Toyota Production System uses a feature called *jidoka*, which basically translates to autonomation (Liker, 2004). *Jidoka* is a device that stops manufacturing if problems are about to or do occur, typically with the use of an andon cord that, when activated, creates a perturbation (Brunner *et al.*, 2009). Workers pull the andon cord, which triggers a sound and lights up a visual control

board, after which workers and the manufacturing leader gather, discuss, and solve the problem by improving the process (exploration). Firms following the Toyota Production System intentionally shrink inventories to low levels (Womack & Jones, 2003). This is done to reduce waste as well as to induce perturbations (Brunner *et al.*, 2010). The low levels of inventories reduce slack and make workers fail in unpredictable ways, thereby inducing perturbations. The use of deliberate perturbations necessitates that employees be trained in problem solving and continuous improvement and that they be empowered, which is the case in firms following the Toyota Production System (Spear & Bowen, 1999). Higher level deliberate perturbations occur during during product development as well. For example, if a product does not qualify according to the expected objectives, be they cost objectives, quality objectives, or customer demands, the development stops and the processes are analyzed, resulting in either the refinement of processes or the development of a different product (Brunner *et al.*, 2010). In sum, the Toyota Production System emphasizes both exploration and exploitation.

Ambidexterity comes in three forms: sequential, structural, and contextual. Sequential ambidexterity means that firms focus on exploration at one point in time and then focus on exploitation at another point in time (Laplume & Dass, 2012); structurally ambidextrous firms dedicate some organizational units to performing exploration and others to pursuing exploitation (O'Reilly & Tushman, 2008). Contextual ambidexterity means that firms build structures that permeate all functions, enabling simultaneous exploitative and exploratory efforts (O'Reilly & Tushman, 2013). Specifically, Gibson and Birkinshaw (2004) describe contextual ambidexterity as a multidimensional construct where flexibility and control each constitute separate, but interrelated, non-substitutable elements that cause the entire organization to integrate and adapt so that the organization may explore and exploit

simultaneously. In Gibson and Birkinshaw's view, contextually ambidextrous firms require a supportive collaborative structure that encourages employees to make their own judgment of how to divide their time between exploration and exploitation.

The contextual form of ambidexterity corresponds with a Lean operation. In a Lean operation firm, all functions and systems are congruent and aligned in order for the firm to achieve success with the implementation of the Lean operation (e.g., Adler *et al.*, 2009; Liker, 2004; Roberts, 2004), and we argue that the roles of finance functions in Lean operation firms are representative of the congruent organizational structures that enable employees to simultaneously perform exploitation and exploration. In the next section, the CVF is described as a means for operationalizing the roles of finance functions in Lean firms, and the hypotheses are developed in the subsequent sections.

9.2.2 The competing values framework and the roles of finance functions

The CVF is used to measure and operationalize the roles of finance functions in Lean firms because it provides a framework for analyzing the underlying organizational structures that must be in place and balanced in order to achieve simultaneous exploration and exploitation (Carmeli & Halevi, 2009). Furthermore, the CVF encompasses the characteristics of exploitation and exploration that are suggested by March (1991). The CVF highlights contradictory yet interdependent organizational components by shedding light on differences between control and flexibility and between internal and external focus (Cameron *et al.*, 2014) (see Figure 1). The combination of these two dimensions—control versus flexibility and internal focus versus external focus—forms four quadrants with different foci (Hooijberg, 1996). The internal focus and flexibility axes form the collaborate

quadrant, which is characterized by an emphasis on internal alignment, autonomy, and cooperation (Cameron *et al.*, 2014). The external focus and flexibility axes define the adhocracy quadrant, which emphasizes growth, adaption to the environment (Lawrence *et al.*, 2009), and innovation (Losonci *et al.*, 2017). The collaborate and the adhocracy quadrants represent exploration. The control and external focus axes form the compete quadrant, where the overarching emphasis is on cost reduction, goal-setting, and increasing productivity (Lawrence *et al.*, 2009). Last, the control and internal focus axes create the control quadrant, which emphasizes consistency and predictability, monitoring of performance, and planning (Cameron *et al.*, 2014). The control and market quadrant represent exploitation, and the four quadrants and their foci represent the distinctions between the four different finance function roles in this paper³². The CVF is depicted in Figure 1.

³² The CVF was developed by Quinn and Rohrbaugh (1981) and it was originally intended for measuring organizational effectiveness. Since then it has been applied in a wide and diverse range of research, such as the investigation of paradoxical leadership behavior (Denison *et al.*, 1995; Buenger *et al.*, 1996), organizational culture and strategy (Bluedorn & Lundgren, 1993) and fit between organizations' value emphases and the environment (Cameron *et al.*, 2014).

Figure 1: The competing values framework

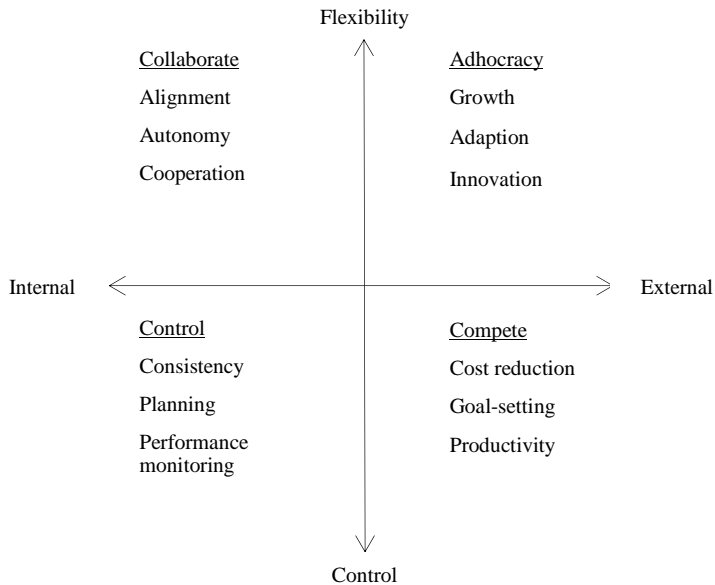

9.2.3 Hypotheses development

9.2.3.1 Lean and exploitative roles of finance functions

Lean firms rely heavily on standardized work (Liker & Meier, 2006), which includes detailed descriptions of the current best known ways for employees to perform work processes. This includes explanations of how work processes should be performed as well as pictures of work processes, which are assigned time intervals including the length of time it should take to carry them out. Standardized work is implemented to reduce variance (Womack & Jones, 2003) and ultimately to provide the highest quality product or service at the lowest cost possible (Liker & Meier, 2006). The use of standardized work and standards requires non-financial

and financial controls to be visualized throughout the organization (Liker, 2004) in order to detect any deviations from the standard and to guide employees. When deviations occur, the focus is on the process, not on the "people" (Emiliani *et al.*, 2003), and analyses of financial and non-financial information are performed. For example, when increasing their emphasis on non-financial information, Lind (2001) found that managers in operations also received standard cost reports and that these were used in concert with non-financial information to analyze flow group performance. Ezzamel and Wilmott (1998) made similar findings in a case firm that restructured operational processes. The firm continued to rely on financial information to control work group performance. Besides providing and analyzing financial and non-financial information, finance functions operate as translators of Lean results and measures to top management (Tillema & van der Steen, 2015). This pertains to Lean progression, project results, and budgeting (Kapanowski, 2017), where budgeting involves cross-functional meetings in which sales and marketing employees provide forecasts of the expected sales for the next 12 months, production employees provide information on capacity levels, and finance employees bring financial information (Maskell *et al.*, 2012). Operations employees also create profit and loss statements pertaining to their value streams, and it is the responsibility of the finance function to do the month-end consolidating reporting (Kapanowski, 2017; Maskell *et al.*, 2012). In ambidextrous firms, control activities are vital in that they ensure stability and certainty and that they connect efforts with clear feedback rapidly (March, 1991). This leads to our first hypothesis:

H1a: The implementation of a Lean operation is positively associated with the control role.

Standardized work in Lean firms is a prerequisite for continuous improvement (Liker & Meier, 2006), and when proven improvements are identified or contingencies change, standards are updated accordingly (Ahrens & Chapman, 2004). Potential improvements are typically analyzed with respect to cost reductions obtained by implementing a changed process (Turney & Stratton, 1992), but costs associated with the implementation are also analyzed; finance functions identify and evaluate the relevant information and calculate the financial impact of the improvement (Kapanowski, 2017). For example, Ezzamel and Wilmott (1998) found that finance function employees were responsible for identifying and calculating the outcomes of different strategies with respect to the restructuring of manufacturing facilities in their case firm. Sharing this information with operations workers enables them to choose between alternatives for improvement and enhances the outcomes of the improvements (Lind, 2001). Cooper (1995) also notes that workers can be expected to effectively commit to targets and achieve cost reductions only if the relevant cost information is shared with them. The sharing of cost information thus helps improve decision making as well as fosters and preserves motivation (Drury, 1992), because workers are assured that their work efforts cause improvements in their firm. The focus on the continuous refinement of current processes increases the likelihood of positive returns for performing these processes (March, 1991). The refinement thus ensures that firms continue to exploit current competencies in a familiar niche (He & Wong, 2004). This leads us to the second hypothesis:

H1b: The implementation of a Lean operation is positively associated with the compete role.

9.2.3.2 *Lean and exploratory roles of finance functions*

The implementation of a Lean operation involves delegating autonomy to employees (Fullerton *et al.*, 2013). This delegation is necessary as employees are expected to execute the day-to-day decisions and continuous improvement related to the Lean operation implementation. Furthermore, breakdowns or delays have severe effects both upstream and downstream in Lean operation firms, as organizational components are tightly coupled (Roberts, 2004). This further substantiates the need for fast decision-making and for empowerment of employees, which requires that employees be provided with the necessary real-time operative information to make well-informed decisions. Lean operation firms transform their management accounting system so that the information is simple (Fullerton *et al.*, 2013) and understandable for operations employees, with an increased emphasis on non-financial information (Lind, 2001; Maskell *et al.*, 2012). McVay *et al.* (2013) argue that the finance function should take the role as a leader in this transformation by listening to suggestions regarding the change of the management accounting system and by collaborating with operations personnel. This echoes the findings of Kennedy and Widener (2008) and Burns and Baldvindsdottir (2005). The provision of the tailored real-time information thus enables the delegation of autonomy to employees, making them capable of executing day-to-day decisions, managing trade-offs, and performing experimentation. Autonomy is important for employees in ambidextrous firms (March, 1991), and it increases their potential to generate innovations (Patel *et al.*, 2013). Thus, we hypothesize the following:

H1c: The implementation of a Lean operation is positively associated with the collaborate role.

Customer value is of paramount importance to Lean firms (Womack & Jones, 2003), and customers are analyzed in the sense that Lean firms acquire information on customer needs and integrate this information into product development and planning activities. The information can be used in radical innovations for new markets or products. Product innovation is based on employee suggestions and information on customer needs obtained, for example, through surveys (Brunner *et al.*, 2010). The processes for radical product innovations are basically similar to those of incremental innovations or improvements but are different in terms of how opportunities or problems are framed (Womack & Jones, 2003), in that radical innovations typically involve a cross-functional effort (Karlsson & Åhlström, 1996). For example, the price that customers are willing to pay for a new product is compared with development and manufacturing costs and a target profit (Modares *et al.*, 2005). Such analysis involves development engineers, operations personnel, and the finance function. This cross-functional framing of product development reduces the equivocality of goals and combines knowledge synergies (Jansen *et al.*, 2009), thus increasing the efficiency and effectiveness of innovations. Finance functions play an important role here because they deal with business fundamentals such as which products should be produced, which customers should be targeted (Ahrens, 1997), and which investments should be undertaken (Järvenpää, 2007). Thus, we hypothesize the following:

H1d: The implementation of Lean operations is positively associated with the adhocracy role.

9.2.3.3 Lean operation and Lean principles in the finance function

As noted, Lean is an enterprise-wide system (Liker, 2004; Shah & Ward, 2007) in which all employees are engaged in continuous improvement (Furlan *et al.*, 2011).

Given that these systems and practices are interdependent (Roberts, 2004), we argue that the implementation of the Lean operation increases the extent to which functions in a Lean operation firm depend on one another for assistance, communication, coordination, and compliance in the performance of their respective tasks. This is not necessarily limited to when finance functions adapt practices and systems congruent with the Lean operation implementation: interdependence among functions in a firm also increases the intra-organizational diffusion of systems and practices, as employees in different functions are more likely to use the same systems and practices (Kim & Srivastava, 1997). Furthermore, the ensuing communication and interaction among employees in different functions enables the sharing and dispersion of ideas (Ross, 1974) on what works and do not work in different functional settings. With respect to a Lean operation, this does not necessarily imply that the entire set of Lean principles is adopted by other functional areas, as their settings are different (Georgescu, 2011). However, McVay *et al.* (2013) argue that transferring Lean to finance functions should include the identification and standardization of all repetitive procedures, a focus on understanding internal customer needs, and an emphasis on continuously improving procedures according to these demands. We thus hypothesize the following:

H2: The implementation of a Lean operation is positively associated with an increased focus on Lean principles in the finance function.

9.2.3.4 Lean principles in the finance function and the roles of finance functions

Lean operation is implemented to eliminate waste, increase efficiency, and to create quality products according to customer demand (Liker, 2004). Research finds that a Lean operation improves lead time (e.g., Khachanapong *et al.*, 2014)

and flexibility (e.g., Bortolotti *et al.*, 2014), which in turn enables workers to increase focus on continuous improvement and innovation, creating value for customers. Studying Lean in a software provider, Staats *et al.* (2011) found that standardization decreased the cognitive focus and the time that workers otherwise spent on repetitive tasks. Relatedly, Granlund and Malmi (2002) found that the automation of repetitive processes resulting from an implementation of an ERP-system freed capacity for finance function workers. Brewer and Kennedy (2013) describe how an implementation of Lean in a finance function freed capacity for workers and enabled them to better serve the needs of their internal customers. Accordingly, we argue that that the implementation of Lean finance frees cognitive and time-wise capacity spent on repetitive tasks such as regulatory reporting, changes focus to improving processes, and enables a greater understanding of internal customer demands. As we elaborated in Sections 2.3.1 and 2.3.2, internal customers in Lean operation firms require finance function roles that support the stability, certainty, and refinement of current operational processes as well as innovation, system alignment, and autonomy. Thus, we hypothesize the following:

H3a: Lean finance is positively associated with the control role.

H3b: Lean finance is positively associated with the compete role.

H3c: Lean finance is positively associated with the collaborate role.

H3d: Lean finance is positively associated with the adhocracy role.

9.2.3.5 Interdependence among finance function roles

According to Gibson and Birkinshaw's (2004) view of contextually ambidextrous organizations, structures in such organizations are non-substitutable and interdependent. This means that an increase or decrease in an innovation activity leads to an increase or decrease, respectively, in an efficiency related activity in

order to maintain the balance between exploration and exploitation (Cao *et al.*, 2009). There is not much evidence of interdependencies among finance function roles. Sathe (1983) argued that interdependencies exist between the functional and local responsibilities of "strong" controllers: by getting more closely involved in local decision-making, they would be in a better position to perform their functional duties. However, Maas and Matejka (2009) found that these responsibilities were in fact substitutes. In their cross-sectional study of the determinants of finance function roles, Chang *et al.* (2014) found that interdependencies existed among three roles, which they labeled strategic partner, performance management and reporting, and compliance and control/risk management. We predict that the four finance function roles are interdependent in Lean operation firms. For example, advice from the finance function pertaining to innovations (the adhocracy role) is more viable if the finance function has substantial knowledge of the current practices in operations (the control role). Similarly, calculations of the effects of potential improvement efforts (the compete role) are better informed if the finance function includes suggestions for improvement stemming from operations (the collaborate role). The development of cost-saving plans (the compete role) is better supported if these plans are based on knowledge of the current performance in operations (the control role). Last, providing strategic advice to operations (the adhocracy role) is more legitimized if the finance function exhibits leadership towards operations (the collaborate role). Based on these arguments³³, the following hypothesis is formulated:

H4: The four roles of finance functions in Lean firms are interdependent.

³³ This argument corresponds with congruence theory and implies that decision makers in Lean firms are aware of the interdependence between the roles of finance functions and that they make, more or less, optimal decisions (Grabner & Moers, 2013).

Figure 2 depicts our research model.

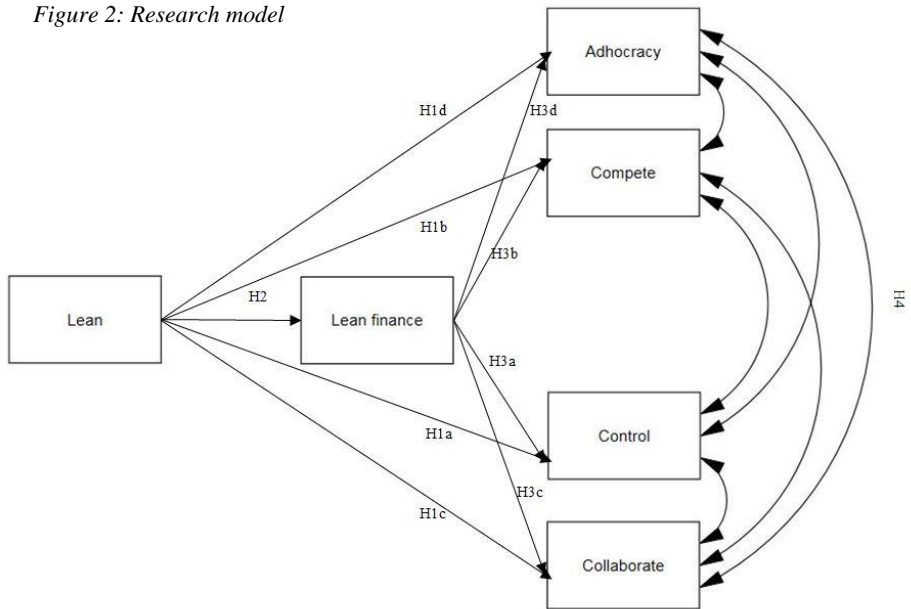

9.3. Methods

9.3.1 Data and sample

Our sample is taken from the Danish database of registered companies, which includes all Danish firms. The database contains information on firm names and addresses, financial information, top management team information, sector codes, and employee information. For the survey, we included privately and publicly held firms as well as firms in the government and not-for-profit sector. Firms had to

have more than 50 employees, and we selected CFOs as our target respondents, as done by other survey research papers on the roles of finance functions (e.g., Chang *et al.*, 2014; Mouritsen, 1996). We identified 1775 usable firms for the survey. Contact information on CFO was collected via telephone, and firms were provided details of the research.

Data collection via email included a link to an online survey instrument, and collection was conducted in two rounds from July 2016 until December 2016. We conducted a third round of data collection via postal mail in January 2017. In total, responses from 525 firms were received, yielding a response rate of 29.5 percent, which is similar to the 10–30 percentage range reported in recent studies in management accounting that survey top management members (e.g., Baines & Langfield-Smith, 2003; Henri, 2006; Widener, 2007). Sample characteristics are presented in Table 1. As accounting data related to control variables was necessary for this paper³⁴, we excluded not-for-profit and government firms from the sample, yielding a sample size of 408 firms. We assessed potential nonresponse bias by comparing responding and nonresponding firms. T-tests were used to compare these groups with respect to the number of employees (respondents vs. nonrespondents $T: .651$ p. $.515$), 2015 revenues (respondents vs. nonrespondents $T: .392$, p. $.695$), and 2015 return on assets (respondents vs. nonrespondents $T: .143$, p. $.633$). None of the results indicated nonresponse bias. Respondents were 48.5 years of age on average, had worked 9 years in the current firm, and had 5.9 years of tenure in their current position. Therefore, they had several years of experience on which to base their answers to the questionnaire.

³⁴ We use archival data to reduce common method bias concerns.

After completing the collection of data from the CFOs, we found names and contact information on the chief operating officer (COO) of the firms for which the CFOs had responded. Two rounds of data collection were performed, one via e-mail and one via postal mail. In total, 107 responses were received. We used the responses from the COOs to investigate interrater agreement of the factors representing the roles of finance functions³⁵ and to ensure their construct validity and reliability. We compared firms in the sample from which only the CFO responded with firms in the subsample for which we received responses from the CFO and the COO. T-tests used to compare groups with respect to the number of employees ($T: .839$, $p. .402$), 2015 revenue ($T: .452$, $p. .652$), and 2015 return on assets ($T: .523$, $p. .601$) did not produce significant results. The COOs were 49.5 years of age on average, had worked 12.6 years in their firms, and had 6.9 years tenure in their current position.

Table 1: Sample characteristics

	Manufacturing $n= 193$		Service $n=215$
Iron and Rubber	30%	Retailing	42%
Machines	30%	Finance	24%
Food	13%	Transportation	14%
Textiles	7%	Utilities	10%
Electronics	6%	Other	7%
Chemicals	4%	Communication	2%
Health-care	4%	Property	1%
Furniture	3%		
Media	2%		
Other	1%		
<i>Total</i>	100%		100%

³⁵ This also reduces the likelihood that our results are driven by social desirability bias.

9.3.2 Variable measurement

The questionnaire consisted of 158 items. However, we included only a portion of the questionnaire for analysis in this paper. All items were measured on a labeled Likert scale with a range of 1–7. Eutsler and Lang (2015) have shown that labeled scales are superior to unlabeled scales as they reduce measurement error, centrality, and extreme response bias. Furthermore, a range of 1–7 increases the variance in the responses (Eutsler & Lang, 2015).

9.3.2.1 Lean production

We measure Lean production in operational areas using five items capturing 1) the degree of flow; 2) the degree of continuous improvement; 3) the degree to which employees are multifunctional; 4) the degree to which the production or operational areas are structured in cells, and 5) the degree to which standardization is implemented in the production or operational areas. All items are based on Fullerton *et al.* (2013).

9.3.2.2 Roles of the finance function

We performed a literature review of empirical research in order to capture a sound base of items pertaining to the roles of finance functions. The terms "controller," "role," "management accounting"/"accountant" and "role" were searched for in paper titles and abstracts in the EBSCO host business source premier database and the ABI/INFORM database. We reviewed 31 papers, of which 23 were published in highly ranked journals³⁶. Mahlendorf (2014) draws attention to the fact that

³⁶ We reviewed 34 papers, of which 23 were published in highly ranked journals: European Accounting Review: 10, Management Accounting Research: 7, Accounting, Organizations and Society: 3, The Accounting Review: 2, and Journal of Management Accounting Research: 1.

finance function roles typically share the characteristics of practiced-defined variables rather than theoretical variables, and he refers to Luft and Shields (2007), who argue that, compared with practiced-defined variables, "...theory-defined variables are more likely to have well-defined, stable, unitary meanings, making it possible to identify consistent cause and effect relations" (pp. 43). In the empirical context of Lean firms, we rely on the CVF to predict relations between Lean and the roles of finance functions, because the CVF captures the organizational structures necessary for contextual ambidexterity (Carmeli & Halevi, 2009). Thus, we use the CVF as a lens to identify items and descriptions of finance function activities in previous research that fit to each quadrant's underlying values. We measure finance function roles via activities to reduce the effects of social desirability bias (Mahlendorf, 2014) and we use a frequency scale to capture the frequency with which respondents "perceived the roles to be part of their work activity rather than [measured] the number of times a given activity was performed" (Floyd & Wooldridge, 1992).

We used four items to measure the adhocracy role. Item 1 was based on Burns and Baldvindsdottir's (2005) findings covering the frequency with which the finance function provides operations with advice on strategic matters. Item 2 was from Maas and Matejka (2009) and was intended to capture the frequency with which the finance function develops new investment potential. Item 3 was adapted from Chang *et al.* (2014) to capture the frequency with which the finance function helps to set strategic imperatives and directions for the firm, and Item 4 was based on the findings of Goretzki *et al.* (2013) to capture the frequency with which the finance function contributes with advice on growth and future potential for the firm.

The compete role was measured using four items. Items 1, 2, and 3 were adapted from Maas and Matejka (2009) to cover the frequency with which the finance

function 1) develops cost-savings plans for the firm, 2) analyzes customer and product profitability, and 3) helps other functions reaching their targets. Item 4 was based on Lambert and Sponems' (2012) findings and covers the frequency with which the finance function promotes fast decision-making.

Four items are used to measure the control role. Item 1 was based on Burns and Baldvindsdottir's (2005) findings and was intended to capture the frequency with which the finance function performs variance analysis of costs incurred and revenue incurred by other functions. Item 2 was adapted from Chang *et al.* (2014) to capture the frequency with which the finance function monitors the performance of other functions. Item 3 was developed on the basis of Goretzki *et al.* (2013) and covers the frequency with which the finance function performs forecasting, while Item 4 was adapted from Mouritsen (1996) to capture the frequency with which the finance function participates in budget preparation and implementation in other functions.

We used four items to measure the collaborate role. We developed Item 1 to capture the frequency with which the finance function exhibits leadership towards other functions in the firm. Item 2 was adapted from Chang *et al.* (2014) to capture the frequency with which the finance function aligns management control systems to the firm's business. Item 3 was based on the findings of Pierce and O'dea (2003) to cover the frequency with which the finance function collaborates with other functions to establish consensus between functions. We developed the fourth item to measure the frequency with which the finance function listens to and helps legitimize other departments' finance related suggestions.

9.3.2.3 *Lean principles in the finance function*

Lean practices used in an operational setting may not be directly translated to the finance function (Dilton-Hill, 2015), and no study has developed measures for assessing the extent of Lean in such a setting. We drew on the Lean service literature. All items were based on Malmbrandt and Åhlström (2013). Item 1 captures the degree to which the finance function understands customers' needs. Item 2 captures the degree to which the finance function performs continuous improvement. Item 3 captures the degree to which finance functions focus on problem solving, and Item 4 captures the extent of standardized work. All survey items can be found in Appendix 2.

9.3.2.3 *Control variables*

Size is controlled for by relating size to all four roles, as size might indicate that firms have more resources at their disposal that can be directed to both exploration and exploitation (Mom *et al.*, 2008). Size is measured as the natural log of the total number of full-time-equivalents employed by the firm. Chang *et al.* (2014) found that environmental uncertainty was positively related to an increased emphasis on compliance and control and on supporting firm growth. We accordingly model a relationship between environmental uncertainty and the control role and between environmental uncertainty and the adhocracy role. Environmental uncertainty is measured by the standard deviation of the sales growth of firms within the same sector during the past three years (Cao *et al.*, 2009). Additionally, we control for debt-to-equity ratio by relating D/E to the compete and control roles, as firms with a greater ratio are expected to emphasize exploitation because they are more prone to meeting cash flow obligations (Choi *et al.*, 2016). D/E is computed as total debt (long-term and current liabilities) divided by the book value of equity. We include

a dummy for respondents' position (CFO or not) since only 66.4 percent of respondents were CFOs³⁷. We also control for whether the firms operate in the services or the manufacturing sector.

9.3.3 Exploratory factor analysis

Although several of the items have been used in prior research, most have not been used in the same analysis. Thus, we conduct an exploratory factor analysis with oblique rotation including all items for the latent variables. The analysis yields six factors with eigenvalues greater than 1 commutatively explaining 59.06 percent of the variance: Lean, Lean finance, the adhocracy role, the compete role, the collaborate role, and the control role (see Table 2). The six factors are in accordance with *a priori* expectations, and their Cronbach's alphas are between .686 and .828, showing adequate to very good reliability (Kline, 2011) (see Table 3). To address the criterion validity of the Lean finance construct, it was correlated with a single item measuring the extent to which Lean is implemented in the finance function. The correlation was significant at $p < .05$, $r: .399$.

Table 2: Exploratory factor analysis and descriptive statistics

Indicator	Lean	Adhocracy role	Compete role	Control role	Collaborate role	Lean finance	Mean	Std. deviation
LP1	.774						5.90	.99
LP2	.756						5.64	1.16
LP3	.650						5.35	1.20
LP4	.588						5.45	1.35
LP5	.608						5.58	1.27
ROLE1		-.787					5.70	1.17
ROLE2		-.663					4.19	1.65
ROLE3		-.788					5.82	1.24

³⁷ Other respondents identified themselves as: "senior finance manager" (6.6 percent), "controller" (2 percent), CEO (2 percent), and "other" (23 percent).

ROLE4		-0.819					4.74	1.60
ROLE5			.630				5.07	1.32
ROLE6			.468				4.90	1.33
ROLE7			.427				5.42	1.53
ROLE8			.737				4.06	1.68
ROLE9				.835			6.55	.95
ROLE10				.555			6.07	1.38
ROLE11				.524			6.17	1.25
ROLE12				.769			6.63	.88
ROLE13					-.708		5.20	1.24
ROLE14					-.756		5.22	1.27
ROLE15					-.851		5.94	1.09
ROLE16					-.781		5.57	1.03
LF1						.482	5.87	1.06
LF2						.753	5.77	.96
LF3						.858	5.66	1.09
LF4						.796	5.66	1.08

KMO of sampling adequacy for factors: .839. Bartlett's Test of Sphericity is significant $p < .000$

Only loadings exceeding .400 are shown

9.3.4 Confirmatory factor analysis

We perform a confirmatory factor analysis in AMOS 23 including all latent variables. This is a two-step procedure where the measurement model without structural paths is evaluated to ensure fit, which is followed by an evaluation of the structural model (Hair *et al.*, 2014). The measurement model is evaluated using several fit indices, as recommended by Kline (2011). We assess χ^2 to degrees of freedom (Bollen, 1989) which should be less than three (Kline, 2005); root mean square error of approximation (RMSEA), which should be below .08 (Browne & Cudeck, 1993); and standardized root mean square residual (SRMR), where a value below .1 indicates acceptable fit (Schermelleh-Engel *et al.*, 2003). Furthermore, we evaluate the comparative fit index (CFI) (Bentler, 1990), incremental fit index (IFI)

(Bollen, 1989), and Tucker-Lewis index (TLI) (Tucker-Lewis, 1973). CFI, IFI, and TLI are evaluated for their closeness to 1.0 (Byrne, 2010), where values above .9 indicate acceptable fit (Bentler, 1992; Kline, 2005). Lastly, we evaluate the Consistent Akaike's Information Criterion (CAIC) addressing model parsimony, taking sample size into account (Bozdogan, 1987) where the ratio of the hypothesized model and the saturated model should be less than one (Byrne, 2010). Although χ^2 is significant (p. <.05), χ^2 to degrees of freedom is 1.74, and fit indices are acceptable (see Table 3).

Table 3: Confirmatory factor analysis, composite reliability and Cronbach's alpha

Factor indicators	Standardized loadings	T-value (All significant p.<.01)	C.R	Alpha
<i>Lean</i>			.720	.705
LP1	.650	7.739		
LP2	.819	8.112		
LP3	.486	6.744		
LP4	.461	a		
LP5	.468	6.593		
<i>Adhocracy role</i>			.840	.828
ROLE1	.694	15.428		
ROLE2	.702	12.173		
ROLE3	.730	a		
ROLE4	.832	14.280		
<i>Compete role</i>			.720	.734
ROLE5	.658	a		
ROLE6	.729	10.982		
ROLE7	.494	8.314		
ROLE8	.617	10.982		
<i>Control role</i>			.730	.686
ROLE9	.742	10.658		
ROLE10	.707	9.387		
ROLE11	.455	7.607		
ROLE12	.729	a		
<i>Collaborate role</i>			.805	.798
ROLE13	.639	a		

ROLE14	.727	11.462		
ROLE15	.784	11.713		
ROLE16	.700	10.902		
<i>Lean finance</i>			.750	.732
LF1	.439	6.961		
LF2	.542	a		
LF3	.808	10.280		
LF4	.798	9.774		

χ^2 to degrees of freedom: 1.745 RMSEA: .043, SRMR: .050, IFI: .941, TLI: .930, CFI: .940, CAIC: .406 (925.26/2278.662 saturated model)

"a" indicates a loading fixed to 1

The factors' convergent validity, discriminant validity, and construct reliability are evaluated as well. Convergent validity is assessed with the fitted standardized residual matrix and the standardized loadings of the factors' indicators (Fullerton & Wempe, 2009). None of the standardized residuals exceeded an absolute value of 2.58, therefore not indicating potential misfit (Jöreskog & Sörbom, 1988), and all standardized loadings on factors are highly significant at $p < .05$, indicating convergent validity³⁸. Discriminant validity is determined by comparing the correlation between factors and their squared average variance extracted (AVE) (Fornell & Larcker, 1981), where the squared AVE of individual factors should be greater than their correlation. Squared AVE is shown at the diagonal in Table 4 and is greater than all factor correlations. Additionally, all factors' composite reliabilities (CR) are above .7, which is the threshold recommended by Hair *et al.* (2014). The measurement model did not indicate any multicollinearity issues, as

³⁸ One of the modification indices was greater than 10, suggesting correlation between the residuals of Item 1 and Item 3 of the adhocracy role. Both items are related to an outward focus on strategy of the finance function. Byrne (2010) states that such modification to a measurement model should only be carried out if it makes substantial sense. Given the similar outward focus of Items 1 and 3, we correlate their residuals in the measurement model.

none of the variance inflation factors were above 1.3, and tolerance statistics were above .75.

Table 4: Factor correlations and squared AVE's

	Lean operation	Adhocracy role	Compete role	Control role	Collaborate role	Lean finance
Lean operation	.594					
Adhocracy role	.240**	.754				
Compete role	.249**	.614**	.629			
Control role	.287**	.368**	.457**	.642		
Collaborate role	.352**	.360**	.488**	.272**	.714	
Lean finance	.431**	.150**	.321**	.350**	.344**	.666

Squared AVE's are shown at the diagonal

** indicates a $p < .05$

We perform another confirmatory factor analysis but only include items pertaining to the variables measuring the finance function roles and only with data from the COO sample. The results of these tests are indicated in table 1 and 2 in Appendix 1. All fit indices and construct validity and reliability indicators are acceptable³⁹. Last, we evaluate interrater agreement using the average deviation index (ADI) (Burke *et al.*, 1999). The ADI is determined by evaluating the extent to which the individual factor item ratings differ from the mean of the factor, then summing the absolute distances, and finally dividing the sum by the number of deviations (Burke *et al.*, 1999). For a 7-point Likert scale, an ADI below 1.714 indicates acceptable inter-factor agreement (Burke and Dunlap, 2002). The ADIs of the four finance role function factors range from .83 (the compete role) to 1.24 (the control role). In sum,

³⁹ Again, a modification indices test suggested a correlation between the residuals of Item 1 and Item 3 of the adhocracy role. In the measurement model pertaining to the responding COOs, these residuals are correlated.

the four roles based on the CVF appear to be a good representation of the roles of finance functions in the Lean operation firms in our sample⁴⁰.

As relationships between exogenous and endogenous variables are tested by only using data from the CFOs, we acknowledge that there is a potential for common method bias (Podsakoff *et al.*, 2003). Although the problem typically is prevalent in single-respondent studies, where the endogenous variables are, for example, self-reported performance (Grabner & Speckbacher, 2016), which does not apply to this study, the potential issue was addressed *ex ante* in that the survey instrument ensured the respondents complete anonymity, and the measurements of exogenous and endogenous variables were randomly ordered. *Ex post*, we addressed the potential common method bias issue by performing the Harman's single-factor test (Podsakoff & Organ, 1986). The test did not reveal a great concern for common method bias, as the one factor including all items only explained 23.6 percent of the variance in the data. Last, we ran tests for linearity of relations between our main exogenous and endogenous variables. All relations were significantly linear with R^2 's ranging from .02 to .124 and t-values ranging from 7.56 to 57.31.

9.4 Empirical tests and results

Before investigating the results of the structural relations, the fit indices of the SEM are assessed. All fit indices exceed the minimum thresholds (see Figure 3). Contextual ambidexterity demands that organizational structures are aligned with the strategy of the firm (Gibson & Birkinshaw, 2004), and we expected this to hold for the roles of finance functions in Lean operation firms (H1a–H1d). Consistent

⁴⁰ Bear in mind that there were no significant differences between firm characteristics in the entire sample of 408 firms compared with the 107 firms from which two responses were received.

with the predictions, the firms in the sample have aligned their finance functions according to the Lean operation, as represented by the positive significant relations between Lean and the control role (std. β : .162, p . <.05), the compete role (std. β : .134, p . .07), the collaborate role (std. β : .250, p . <.05), and the adhocracy role (std. β : .205, p . <.05) (see Table 5 and Figure 3). These results suggest that when firms increase their implementation of a Lean operation, finance functions intensify their work efforts pertaining to efficiency, control, and variance reduction (i.e., exploitation), and search, discovery, autonomy, and innovation (i.e., exploration)⁴¹. Further, we predicted that the implementation of Lean operation would lead to an intra-organizational diffusion process of Lean principles to the finance function (H2). The result confirms our prediction (std. β : .431, p . <.05). As such, the fact that systems and practices in Lean operation firms are tightly coupled allows knowledge sharing and transfer of ideas and systems across functional boundaries, in this case, from operations to the finance function.

Regarding Hypotheses 3a–3d, we predicted that Lean finance would lead to a greater emphasis on all four finance function roles, as Lean finance frees up capacity and enables a greater understanding of internal customer needs. Three hypotheses were confirmed, as Lean finance is positively related to the control role (std. β : .270, p . <.05), compete role (std. β : .264, p . <.05), and collaborate role (std. β : .236, p . <.05). The relation between Lean finance and the adhocracy role was not significant (std. β : .049, p . .477). Given that the relation between Lean operation and the adhocracy role is significant, this insignificant result suggests that the

⁴¹ We decided to test for other forms of relationships. Linear relationships were generally the best representations of associations between Lean operations and the four finance function roles. However, a quadratic relation between Lean operation and the collaborate role proved to explain .01 more variance, although with a lower t-value. We have no plausible explanation for this relationship and it remains something for future research to resolve.

emphasis on the adhocracy role is a function of a demand for this role to support the Lean operation implementation rather than a function of a supply of resources resulting from freed capacity. The results suggest that Lean finance frees up capacity and enables a greater understanding of customer needs⁴². To provide evidence of H4, the residuals of the four finance function roles are correlated (Grabner & Moers, 2013). In order to confirm the hypothesis, all correlations must be significant and positive. The results confirm the predictions as all pair-wise correlations are significant and positive, $p < .05$. We also assess indirect effects⁴³ (see Table 5). Lean is positively indirectly related to the compete role, the control role, and the collaborate role, and the total effects are greater than the direct effects. These results suggest that Lean operation and Lean finance intervene and increase the emphasis on these three roles.

As a robustness check, control variables are entered in our structural model and paths are modeled, as indicated in Section 3.2.3. Although the relation between environmental uncertainty and the control role (std. β : .105, $p < .05$) is significant, and the relationships between CFO_{res}⁴⁴ and the adhocracy role (std. β : .150, $p < .05$), the compete role (std. β : .223, $p < .05$), the control role (std. β : .091, $p < .074$), and the collaborate role (std. β : .146, $p < .05$) are significant, our statistical inferences remain similar⁴⁵. In a third model, we relax our assumption of

⁴² We acknowledge that R^2 's of role variables are relatively low (see Figure 3). However, they are similar to the R^2 's ranging from 8.24 to 14.61 percent presented by Chang *et al.* (2014) in a survey paper on the determinants of finance function roles.

⁴³ This analysis is performed by a boot-strapping procedure in AMOS with 2000 samples. In order to perform this test, missing values are replaced using the expectation maximization method. Little's MCAR tests of all individual items did not reveal that missing values appeared in a non-random fashion.

⁴⁴ If the respondent was CFO = 1 or not = 0.

⁴⁵ To reduce unobserved heterogeneity issues (Grabner & Moers, 2013) concerning H4, we also ran a test where all control variables were related to all roles. The results were similar

interdependence among finance function roles. The resulting model fits the data significantly worse (χ^2 231.1 p. < .05). Altogether, the results of the main model are robust.

Table 5: Results

Panel A: Main results		Main model		Model with control variables	
Relationships	Hypothesis	Std. Coefficients	T-values	Std. Coefficients	T-values
Lean operation => Control role	H1a	.162	2.327**	.153	2.200**
Lean operation => Compete role	H1b	.134	1.793*	.130	1.750*
Lean operation => Collaborate role	H1c	.250	3.335**	.258	3.413**
Lean operation => Adhocracy role	H1d	.205	2.756**	.208	2.765**
Lean operation => Lean finance	H2	.431	5.230**	.430	5.211**
Lean finance => Control role	H3a	.270	3.807**	.263	3.732**
Lean finance => Compete role	H3b	.264	3.375**	.246	3.201**
Lean finance => Collaborate role	H3c	.236	3.325**	.220	3.110**
Lean finance => Adhocracy role	H3d	.049	.711	.041	.596
Compete role <=> Control role	H4	.390	5.174**	.372	4.981**
Compete role <=> Collaborate role	H4	.408	5.012**	.387	4.761**
Control role <=> Collaborate role	H4	.161	2.440**	.160	2.429**
Adhocracy role <=> Compete role	H4	.771	8.014**	.767	7.992**
Adhocracy role <=> Control role	H4	.285	4.159**	.272	4.010**
Adhocracy role <=> Collaborate role	H4	.294	4.160**	.279	3.971**
Panel B: Indirect and total effects		Indirect effects	Total effects	Indirect effects	Total effects
Independent variable	Dependent variable	Std. Coefficients		Std. Coefficients	
Lean operation	Compete role	.114**	.248**	.106**	.236**
Lean operation	Control role	.117**	.279**	.113**	.266**
Lean operation	Collaborate role	.102**	.352**	.095**	.352**
Lean operation	Adhocracy role	.021	.227**	.018	.226**
Panel C: Control variables		Dependent variables			
		Std. Coefficients			
	Adhocracy role	Compete role	Control role	Collaborate role	
Size	-.043	-.003	.066	-.004	
CFO _{res}	.150**	.233**	.091*	.146**	
Environmental uncertainty	.041		.105**		

to the main model as correlations between residuals of all finance function roles remained positive and significant.

Debt-to-equity		.018		-.048
Sector	.017	-.054	-.003	.030

** indicates a p.<.05

*indicates a p.<.10

Figure 3: results model

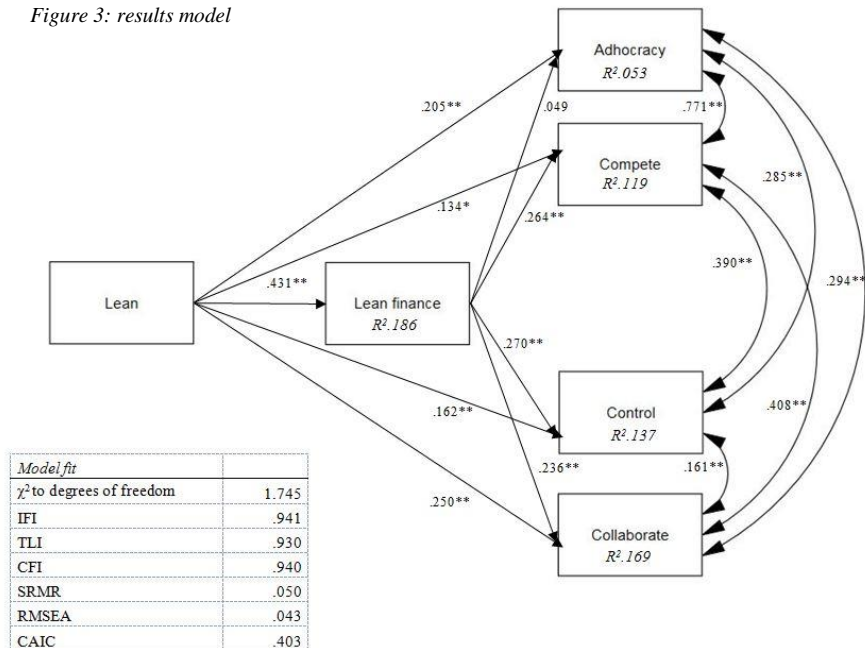

Note: The results in the structural model are depicted without control variables. **indicates a p. <. 05, *indicates a p. <.10.

9.5 Discussion and conclusion

This paper set out to explore the relations between Lean and the roles of finance functions. Although a few case studies have described how the implementation of Lean affected the roles of finance functions, this is a neglected topic in the literature. Cooper (1996) predicted a dystopian future for finance function workers in Lean operation firms when he suggested that much of their work would be transferred to operations employees and that, if finance workers were to have any relevance in Lean operation firms, they would have to develop and perfect skills in strategy, system design, and change management. This prediction is maintained in more recent literature on Lean accounting (Maskell *et al.*, 2012). In this research, we show that their predictions only tell part of the story, and we make several contributions to the literature. We characterized Lean operation firms as contextually ambidextrous (Gibson & Birkinshaw, 2004). We predicted that finance functions were the representatives of the necessary structural parameters that enable employees in Lean operation firms to balance exploration and exploitation.

We found that Lean operation firms emphasized the collaborate role, focusing on collaboration, empowerment, and the alignment of systems. As such, finance functions in our sample play a part in changing and aligning management control systems to firms' Lean operation, and they incorporate suggestions from operations personnel to make the management control system congruent with their needs (Burns & Baldvindsdottir, 2005). The latter is important in Lean operation firms because operations employees need to be empowered in order to make timely, well-informed decisions, as they have low buffers to secure them against breakdowns (Liker, 2004). From a broader perspective, the collaborate role differs from the more traditional finance function work. This indicates that the finance

function can indeed support organizational changes (Granlund & Taipaleenmäki, 2005) by working closely together with other functional areas of the firm (Ezzamel *et al.*, 2008), ensuring that financial matters remain a priority. The close cooperation emphasized by the collaborate role increases the likelihood that the "offer" from finance functions to other functions involves meeting the demands of these functions (Lambert & Sponem, 2012). Additionally, we found that an increase in Lean operation was related to an increased emphasis on the adhocracy role. The adhocracy role connects customer demands with operations which, of course, are of great importance to Lean operation firms (Womack & Jones, 2003). This role provides the calculative skills necessary for evaluating manufacturing and development costs and the price that customers are willing to pay for a new product or service; it also evaluates which customers should be targeted based on financial criteria (Ahrens, 1997).

However, we also found that Lean operation firms emphasized the control role. The control role focuses on monitoring and analyzing operations performance and the preparation of budgets. This finding is in contrast to Burns and Baldvindsdottir's (2005) findings. Likewise, although there has been an increasing emphasis on non-financial controls in recent research (Fullerton *et al.*, 2013; Fullerton *et al.*, 2014; Staats *et al.*, 2011), the reliance on the control role indicates that financial controls remain important in Lean operation firms. The Lean operation firms in our sample also emphasize the compete role. The main focus of this role is cost reductions, and it provides operations with financial information pertaining to the improvement potential of work processes and products. This information improves the foundation on which operations personnel can base their choice of improvement and better enables them to choose between alternatives (Lind, 2001).

Furthermore, we find that the four finance function roles are interdependent. This implies that the managerial choice of emphasizing one role and the "usefulness" of this role depend on the choice of emphasizing the other roles and vice versa in Lean operating firms. If this interdependence is not recognized by decision-makers in a Lean operation firm, for example if they only employ the control role and the compete role or exaggerate focus on the collaborate and adhocracy roles, they might end up overemphasizing exploitation or exploration, respectively, which inevitably leads to negative consequences for the firm (March, 1991).

The finance functions in our sample of Lean operation firms adapt Lean principles. We argue that they do so because systems and practices in Lean firms are tightly coupled (Roberts, 2004), which enables sharing of knowledge and ideas (Ross, 1974), which in turn initiates an intraorganizational diffusion of Lean principles from operations to the finance function. We find that the adaption of Lean principles in finance functions induces a further emphasis on the control, compete, and collaborate roles. Likewise, the adoption of Lean principles in the finance function works as a catalyst, as it reinforces the relationship between Lean and these three roles. We interpret this finding as an indicator that Lean principles in the finance function leverage finance functions' understanding of operations workers' demands as a result of the intraorganizational diffusion of Lean principles and that this also results in increased internal customer focus. As such, Lean principles in the finance function further connect and integrate operations and finance functions in Lean operation firms.

Our findings are relevant for practitioners in Lean operation firms. First, they should acknowledge that the inclusion of finance function workers is integral to success with Lean implementation. Second, they should understand that a balanced emphasis on finance function roles is necessary to avoid dysfunctional

consequences stemming from overemphasizing certain roles. Third, they should understand the benefits from integrating Lean principles to the finance function, as this increases the understanding of customer demands.

Methodologically, this paper brings a new measurement instrument for the roles of finance functions in Lean firms. We performed a literature review of papers dealing with finance function roles in order to capture items relevant for our research purposes, and we used the CVF (Cameron *et al.*, 2014) as an ex ante guidance for developing the instrument to cover finance function roles in Lean firms. We went to great lengths to ensure the construct validity and reliability of the instrument. We utilized a dyadic approach (Schäffer, 2007) and collected responses from both CFOs and COOs. The measurement instrument proved to be an adequate representation of the roles of finance functions in Lean firms, as fit indices, construct validity and reliability indicators, and the average deviation index were acceptable.

9.6 Future research and limitations

As with any other cross-sectional study, we cannot claim causal inferences. Our evidence must be considered as consistent with our theoretical arguments. Second, having only one respondent as an indicator for both exogenous and endogenous variables presents a potential common method bias problem. However, we addressed this problem ex ante and ex post and found that it was of little concern. Third, although they are comparable to recent survey research on the roles of finance functions (Chang *et al.*, 2014), our results should be interpreted with caution, as the R^2 s of endogenous variables are relatively low.

We encourage future research that refines our measurement instrument. Furthermore, as the measurement reflects finance function roles related to

exploration and exploitation, we suggest that it be used to explore finance function roles in other firms encompassing ambidextrous characteristics. An in-depth case study of the intraorganizational diffusion of Lean practices from operations to other functions and vice versa is an interesting future research endeavor, as current research provides little detail of such processes (Flight & Palmer, 2013). Last, we have no measure of the level of experience that the firms in the sample have with Lean operations. A future research possibility is then to study if the level of experience with Lean affects the relationships between Lean operations and the roles of finance functions. Our research is the initial step in understanding the roles of finance functions in Lean operating firms, and several research avenues lie ahead.

9.7 Appendix 1

Appendix 1: Table 1: COO Confirmatory factor analysis, composite reliability and Cronbach's alpha

Factor indicators	Standardized loadings	T-value (All significant p.<.01)	C.R	Alpha	Mean	Std. Dev.
<i>Adhocracy role</i>			.824	.816		
ROLE1	.744	8.73			5.48	1.32
ROLE2	.535	5.51			3.87	1.71
ROLE3	.861	a			5.59	1.46
ROLE4	.775	8.73			4.37	1.61
<i>Compete role</i>			.777	.759		
ROLE5	.670	a			5.27	1.36
ROLE6	.767	6.42			5.09	1.36
ROLE7	.611	5.38			4.85	1.67
ROLE8	.708	6.37			3.81	1.69
<i>Control role</i>			.821	.786		
ROLE9	.864	8.01			6.38	1.39
ROLE10	.747	7.32			5.91	1.63
ROLE11	.551	7.68			5.78	1.86
ROLE12	.745	a			6.53	1.11
<i>Collaborate role</i>			.837	.830		
ROLE13	.761	a			4.50	1.67

ROLE14	.652	6.42	4.45	1.70
ROLE15	.875	8.85	4.87	1.59
ROLE16	.699	7.02	5.21	1.49

χ^2 to degrees of freedom: 1.606 RMSEA: .075, SRMR: .083, IFI: .927, TLI: .908, CFI: .925, CAIC: .480 (373.29/772.77 saturated model)

"a" indicates a loading fixed to 1

Appendix 1: table 2 COO factor correlations and squared ave

	Collaborate role	Adhocracy role	Compete role	Control role
Collaborate role	.751			
Adhocracy role	.546***	.739		
Compete role	.685***	.648**	.683	
Control role	.346***	.452**	.408**	.735

*** indicates a p. <.05

Squared average variance extracted is indicated at the diagonal

9.8 Appendix 2

Appendix 2

Table 1: Survey Items

Lean Operation

Please indicate the level of agreement regards to whether the production area or similar areas have adapted the following

1: strongly disagree, 2: mostly disagree, 3: slightly disagree, 4: neutral, 5: slightly agree, 6: agree, 7:strongly agree

LP1	Flow
LP2	Continuous Improvement
LP3	Multifunctional employees
LP4	Value Streams
LP5	Standards for operational processes

Control

Please indicate the frequency of which the finance function perform the following activities

1: never, 2: very rarely, 3: rarely, 4: occasionally, 5: frequently, 6: very frequently, 7: almost always

ROLE13	Variance analysis of cost and revenue incurred in other functions
ROLE14	Monitors performance of other functions
ROLE15	Forecasting
ROLE16	Prepares and implements budgets in other functions

Compete

Please indicate the frequency of which the finance function perform the following activities
1: never, 2: very rarely, 3: rarely, 4: occasionally, 5: frequently, 6: very frequently, 7:
almost always

ROLE9	Develops cost-savings plans for the business
ROLE10	Analyzes customer/product profitability
ROLE11	Helps other functions to meet performance targets
ROLE12	Promotes fast decision-making

Collaborate Role

Please indicate the frequency of which the finance function perform the following activities
1: never, 2: very rarely, 3: rarely, 4: occasionally, 5: frequently, 6: very frequently, 7:
almost always

ROLE1	Exhibits leadership towards other functions in the firm
ROLE2	Aligns finance and operational systems with the business
ROLE3	Collaborates with other functions and establishes consensus among them
ROLE4	Actively listens to and legitimizes other employees' suggestions that affects the firm's financials

Adhocracy

Please indicate the frequency of which the finance function perform the following activities
1: never, 2: very rarely, 3: rarely, 4: occasionally, 5: frequently, 6: very frequently, 7: almost
always

ROLE5	Provides advice on strategic matters to operations
ROLE6	Develops and evaluates investment opportunities for the business
ROLE7	Helps to set strategic directions and imperatives for the business
ROLE8	Provides advice concerning growth and future potentials for the business

Lean finance

Please indicate the level of agreement regards to whether the finance function has adapted the following
1: strongly disagree, 2: disagree, 3: slightly disagree, 4: neutral, 5: slightly agree, 6: agree, 7: strongly agree

LF1	Flow Clear understanding of internal customers' needs
LF2	needs
LF3	Motivational efforts pertaining to continuous improvement
LF4	Continuous improvement

9.9 Literature

- Adler, P. S., Borys, B. (1996). Two types of bureaucracy: Enabling or coercive. *Administrative Science Quarterly*. Vol. 41, pp. 61-89.
- Adler, P. S. (1999). Building better bureaucracies. *Academy of Management Executive*. Vol. 13, No. 4, pp. 36-47.
- Adler, P. S., Benner, M., Brunner, J. D., MacDuffie, J. P., Osono, E., Staats, B. R., Takeuchi, H., Tushman, M. L., Winter, S. G. (2009). Perspectives on the productivity dilemma. *Journal of Operations Management*, vol. 27, pp. 99-113.
- Ahrens, T. (1997). Strategic interventions of management accountants: everyday practice of British and German brewers. *European Accounting Review*, Vol. 6, No. 4, pp. 557-588.
- Ahrens, T., Chapman, C. S. (2000). Occupational identity of management accountants in Germany and Britain, *European Accounting Review*, Vol. 9, no. 4, pp. 477-498.
- Ahrens, T., Chapman, C. S. (2004). Accounting for flexibility and efficiency: A field study of management control systems in a restaurant chain. *Contemporary Accounting Research*, Vol. 21 (2), pp. 271-301.
- Anderson, D. R. The function of industrial controllership. *The Accounting Review*, Vol. 19, no. 1, pp. 55-65.
- Baines, A., Langfield-Smith, K. (2003). Antecedents to management accounting change: A structural equation approach. *Accounting, Organizations and Society*, vol. 28, pp. 675-698.

- Bentler, P. M. (1990). Comparative fit indexes in structural models. *Psychological Bulletin*, Vol. 107, pp. 238-246.
- Bentler, P. M. (1992). On the fit of models to covariances and methodology to the *Bulletin. Psychological Bulletin*, Vol. 112, pp. 400-404.
- Big eight white paper. (1988). *Perspectives on education: Capabilities for success in the accounting profession*. New York: Arthur Andersen & Co., Arthur Young, Coopers and Lybrand, Deloitte Haskins & Sells, Ernest & Whinney, Peat Marvick Main & Co, Price Waterhouse and Touche Ross.
- Bluedorn, A. C., Lundgren, E. F. (1993). A Culture-Match Perspective for Strategic Change. *Research in Organizational Change and Development*. Vol. 7, pp. 137-179.
- Bollen, K. A. (1989), *Structural equation with latent variable*. Wiley: New York, NY.
- Bortolotti, T., Danese, P., Flynn, B. B., Romano, P. (2015). Leveraging fitness and lean bundles to build the cumulative performance sand cone model. *International Journal of Production Economics*. Vol. 162, pp. 227-241.
- Bozdogan, H. (1987). Model selection and Akaike's information criteria (AIC): The general theory and its analytical extensions. *Psychometrika*, Vol. 52, pp. 345-370 .
- Brewer, P. C., Kennedy, F. A. (2013). Putting Accountants on a Lean Diet. *Strategic Finance*, February, pp. 27-34.
- Browne, M. W., Cudeck, R. (1993). *Alternative ways of assessing model fit*. In: Bollen, K. A. Long, J. S. (Eds.). *Testing Structural Equation Models*. Sage, Newbury Park, California, pp. 136-162.

- Brunner, D. J., Staats, B. R., Tushman, M. L., Upton, D. M. (2010). Wellsprings of creation: How perturbations sustains exploration in mature organizations. *Harvard Business School Working Paper*, no. 09-011.
- Buenger, V., Daft, R. L., Conlon, E. T., Austin, J. (1996). Competing Values in Organizations: Contextual Influences and Structural Consequences. *Organization Science*. Vol. 7, No. 5, pp. 557-576.
- Burke, M. J., Dunlap, W. P. (2002). Estimating interrater agreement with the average deviation index: A user's guide. *Organizational Research Methods*. Vol. 5, No. 2, pp. 159-172.
- Burke, M. K., Finkelstein, L. M., Dusig, M. S. (1999). On average deviation indices for estimating interrater agreement. *Organizational Research Methods*. Vol. 2, pp. 49-68.
- Burns, J., Baldvindsdottir, G. (2005). An institutional perspective of accountants' new roles – the interplay of contradictions and praxis. *European Accounting Review*. Vol. 14, No. 4, pp. 725-757.
- Byrne, B. M. (2010). *Structural Equation Modeling with AMOS – Basic Concepts, Applications, and Programming*. 2nd edition, Routledge, Taylor & Francis Group. New York.
- Caglio, A. (2003). Enterprise resource planning and accountants; toward hybridization? *European Accounting Review*, Vol. 12, no. 1, pp. 123-153.
- Cameron, Kim S., Robert E. Quinn., Jeff Degraff & Anjan V. Thakor. (2014). *Competing Values Leadership*. New Horizons in Management, 2nd edition.

- Cao, Q., Gedajlovic, E., Zhang, H. (2009). Unpacking organizational ambidexterity: Dimensions, contingencies and synergistic effects. *Organization Science*, vol. 20, No. 4, pp. 781-796.
- Chang, H., Ittner, C. D., Paz, M., T. (2014). The multiple roles of the finance organization: Determinants, effectiveness, and the moderating influence of information system integration. *Journal of Management Accounting Research*, vol. 26. No. 2, pp. 1-32
- Choi, B., Shyam Kumar, M. V., Zambuto, F. (2016) Capital structure and innovation trajectory: The role of debt in balancing exploration and exploitation. *Organization Science*, vol. 27, pp. 1183-1201.
- Carmeli, A., Halevi, M, Y. (2009). How top management behavioral integration and behavioral complexity enable organizational ambidexterity: The moderating role of contextual ambidexterity, *The Leadership Quarterly*, vol. 20, pp. 207-218.
- Cooper, R. (1995). *When Lean Enterprises Collide*. Harvard Business School Press: Massachusetts.
- Cooper, R. (1996). Look Out, Management Accountants. *Management Accounting*, vol. 77, No. 11, pp. 20-26
- Denison, D, R., Hoiijberg, R., Quinn, R, E. (1995). Toward a Theory of Behavioral Complexity in Managerial Leadership, *Organization Science*. Vol. 6, No. 5, pp. 524-540.
- Dilton-Hill, K. (2015). Lean in finance. *The Journal of Corporate Accounting & Finance*. March/April, pp. 15-25.

- Drury, C. 1992. *Standard Costing*. Academic Press Limited.
- Emiliani, M. L., Stec, D., Grasso, L. (2003). *Better thinking, better results*. The Center for Lean Business Management, LLC. Kensington, Connecticut.
- Ezzamel, M., Wilmott, H. (1998). Accounting for Teamwork: A Critical Study of Group-Based Systems of Organizational Control. *Administrative Science Quarterly*. Vol. 43, No. 2, pp. 358-396.
- Ezzamel, M., Wilmott, H., Worthington, F. (2008). Manufacturing shareholder value: The role of accounting in organizational transformation. *Accounting, Organizations and Society*. Vol. 33, pp. 107-140.
- Eustler, J., Lang, B. (2015). Rating scales in accounting research: The impact of scale points and labels. *Behavioral Research in Accounting*, Vol. 27 No. 2, pp. 35-51.
- Flight, R. L., Palmer, R. J. (2013). Organizational structure and intra-firm innovation diffusion. *The Marketing Management Journal*, vol. 23, no. 2, pp. 35-57
- Floyd, S. W., Wooldridge, B. (1992). Middle management involvement in strategy and its association with strategic type: A research note. *Strategic Management Journal*, vol. 13, pp. 153-167.
- Fornell, C., and Larcker, D. F. 1981. Evaluating structural equation models with unobservable variables and measurement error. *Journal of Marketing Research*, vol, 43, pp. 39–50.
- Fullerton, R. R., Wempe, W. F. (2009). Lean manufacturing, non-financial performance measures, and financial performance. *International Journal of*

Production Management, Vol. 29 No. 3, pp. 214-240.

Fullerton, R. R., Kennedy, F., Widener, S. K. (2013). Management accounting and control practices in a lean manufacturing environment. *Accounting, Organizations and Society*, Vol. 38, pp. 50-71.

Fullerton, R. R., Kennedy, F., Widener, S. K. (2014). Lean manufacturing and firm performance: The incremental contribution of lean management accounting practices. *Journal of Operations Management*, Vol. 32, pp. 414-428.

Furlan, A., Vinelli, A., Dal Pont, G. (2011). Complementarity and lean manufacturing bundles: An empirical analysis. *International Journal of Operations & Production Management*, Vol. 31 No. 8, pp. 835-850.

Georgescu, D. D. (2011). Lean Thinking and Transferring Lean Management – The Best Defense against an Economic Recession. *European Journal of Interdisciplinary Studies*. Vol. 3, No. 1, pp. 4-20.

Gibson, C. B. Birkinshaw, J. (2004). The antecedents, consequences, and mediation role of organizational ambidexterity. *Academy of Management Journal*, vol. 47. No. 2, pp. 209-226.

Goretzki, L., Strauss, E., Weber, J. (2013). An institutional perspective on the changes in controllers' professional role, *Management Accounting Research*, vol. 24, pp. 41-63.

Grabner, I., Moers, F. (2013). Management control as a system or a package? Conceptual and empirical issues. *Accounting, Organizations & Society*, Vol. 38, pp. 407-419.

Grabner, I., Speckbacher, G. (2016). The cost of creativity: A control perspective.

- Accounting, Organizations and Society*, vol. 48, pp. 31-42.
- Granlund, M., Lukka, K. (1998). Towards increasing business orientation: Finnish management accountants in a changing cultural context. *Management Accounting Research*, Vol. 9, no. 2, pp. 185-211.
- Granlund, M., Malmi, T. (2002). Moderate impact of ERPS on management accounting: a lag or permanent outcome? *Management Accounting Research*, Vol. 13, pp. 299-321.
- Granlund, M., Taipaleenmäki, J. (2005). Management control and controllership in new economy firms – a life cycle perspective. *Management Accounting Research*, Vol. 16, pp. 21-57.
- Hair, J., Black, W., Babin, B., Anderson, R. (2014). *Multivariate data analysis* (7th ed.). Pearson Education Limited. Edinburgh, England.
- He, Z-L., Wong, P-K. (2004). Exploration vs. Exploitation: An empirical test of the ambidexterity hypothesis. *Organization Science*. Vol. 15, No. 4, pp. 481-494.
- Henri, J-F. (2006). Organizational culture and performance measurement systems. *Accounting, Organizations and Society*, vol. 31, pp. 77-103.
- Hooijberg, R. (1996). A Multidirectional approach toward leadership: An extension of the concept of behavioral complexity. *Human Relations*, vol. 49, No. 4, pp. 917-946.
- Jansen, J. J. P., Van Den Bosch, F. A. J., Volberda, H. W. Exploratory innovation, exploitative innovation, and performance. Effects of organizational antecedents and environmental moderators. *Management Science*, 52, pp. 1661-74.

- Jazayeri, M., Hopper, T. (1999). Management accounting within world class manufacturing: a case study. *Management Accounting Research*. Vol. 10, pp. 263-301.
- Järvenpää, J. (2007). Making business-partners: A case study on how management accounting culture was changed, *European Accounting Review*, vol. 16, No. 1, pp. 99-142.
- Jöreskog, K.G., Sorbom, D. (1988), LISREL 7: A Guide to the Program and Applications, SPSS, Inc., Chicago, IL.
- Kapanowski, G. (2017). Lean strategy implementation: Success is achievable through the accountant. *Cost management*, Jan/Feb, pp. 42-47.
- Karlsson, C., Åhlström, P. (1996). The difficult path to Lean product development. *Journal of Production Innovation Management*, vol. 13, pp. 283-295.
- Kennedy, F. A., Widener, S. K. (2008). A control framework: Insights from evidence on Lean accounting. *Management Accounting Research*, Vol. 19 No. 4, pp. 301-323.
- Khanchanapong, T., Prajogo, D., Sohal, A., S., Cooper, B., K., Yeung, A., C., L., Cheng, T., C., E. (2014). The unique and complementary effects of manufacturing technologies on manufacturing and operational performance. *International Journal of Production Economics*, Vol. 153, pp. 191-203.
- Kim, N., Srivastava, R. K. (1998). Managing Intraorganizational Diffusion of Technological Innovations. *Industrial Marketing Management*. Vol. 27, pp. 229-246.
- Kline, R.B. (2005). Principles and practice of structural equation modeling, 2nd edition. New York: The Guildford Press.

- Kline, R. B. (2011), *Principles and practice of structural equation modeling*, 3rd edition. New York: The Guildford Press.
- Lambert, C., Sponem, S. (2012). Role, Authority and Involvement of the Management Accounting Function: A Multiple Case-study Perspective. *European Accounting Review*, vol. 21, No. 3, pp. 565-589.
- Laplume, A. O., Dass, P. (2012). Exploration and exploitation for various stages of firm growth through diversification. Paper presented at the annual meetings of the Academy of Management, Boston.
- Lawrence, K. A., Lenk, P., Quinn, R. E. (2009). Behavioral complexity in leadership: The psychometric properties of a new instrument to measure behavioral repertoire, *The Leadership Quarterly*, vol. 20, pp. 87-102.
- Levinthal, D., March, J. G. (1993). Myopia of learning. *Strategic Management Journal*, vol. 14, pp. 95-112.
- Levitt, B., March, J. G. (1988). Organizational learning. In W. R. Scott (Ed.), *Annual review of sociology*, vol. 14, pp. 319-340. Palo Alto, CA.
- Liker, J. (2004). *The Toyota Way*. McGraw-Hill. New York.
- Liker, J., Meier, D., 2006. *The Toyota Way Fieldbook*. McGraw-Hill. New York.
- Lind, J. (2001). Control in world class manufacturing – A longitudinal case study. *Management Accounting Research*, vol. 12, pp. 41-74.
- Losonci, D., Kasa, R., Demeter, K., Heidrich, B., Jenei, I. (2017). The impact of shop floor culture and subculture on lean production practices. *International Journal of Operations and Production Management*, vol. 37, No. 2, pp. 205-225.
- Luft, J. Shields, M. D. (2007). Mapping management accounting. Graphics and guidelines for theory-consistent empirical research. In *Handbook of*

- Management Accounting Research*, Vol. 1, Eds.: Chapman, C. S., Hopwood, A. G., Shields, M. D., pp. 27-95. Oxford: UK.
- Maas, V, S., Matejka, M. (2009). Balancing the Dual Responsibilities of Business Unit Controllers: Field and Survey Evidence, *The Accounting Review*, vol. 84, No. 4, pp. 1233-1253.
- Mahlendorf, M. D. (2014). Discussion of the roles of the finance organization: Determinants, effectiveness, and the moderating influence of information system integration, *Journal of Management Accounting Research*, vol. 26, No. 2, pp. 33-42.
- Maleyeff, J. (2006). Exploration of internal service systems using lean principles. *Management Decision*, vol. 44, No. 5, pp. 674-689.
- Malmbrandt, M., Åhlström, P. (2013). An instrument for assessing lean service adoption. *International Journal of Operations and Production Management*, vol. 33, no. 9, pp. 1131-1165.
- March, J. G. (1991). Exploration and exploitation in organizational learning. *Organization Science*, vol. 2, pp. 71-86.
- Maskell, B., Baggaley, B., Grasso, L. (2012). *Practical Lean Accounting – A Proven System for Measuring and Managing the Lean Enterprise*, CRC Press, second edition. Boca Raton, Florida.
- McVay, G., Kennedy, F., Fullerton R. (2013). *Accounting in the Lean enterprise – providing simple, practical, and decision-relevant information*. CRC Press, Taylor & Francis Group: Florida.
- Modarress, B., Ansari, A., Lockwood, D. L. (2005). Kaizen costing for lean manufacturing: a case study. *International Journal of Production Research*. Vol.

43, No. 9, pp. 1751-1760.

Mom, T. J., Frans, A., Van den Bosch, J. Volberda, H. W. (2009). Understanding variation in managers' ambidexterity: Investigating direct and interaction effects of formal structural and personal coordination mechanisms. *Organization Science*, vol. 20, no. 4, pp. 812-828.

Mouritsen, J. (1996). Five aspects of accounting department's work, *Management Accounting Research*, 7, pp. 283-303.

Netland, T. H., Schloetzer, J. D., Ferdows, F. (2015). Implementing corporate lean programs: The effect of management control practices. *Journal of Operations Management*, Vol. 36, pp. 90-102.

O'Reilly, C., Tushman, M. L. (2008). Ambidexterity as a dynamic capability: Resolving the innovator's dilemma. *Research in Organizational Behavior*, vol. 28, pp. 185-206.

O'Reilly, C., Tushman, M. L. (2013) Organizational ambidexterity: past, present, and future. *The Academy of Management perspectives*, vol. 27, No. 4, pp. 324-338.

Pierce, B., O'Dea, T. (2003). Management accounting information and the needs of managers perceptions of managers and accountants compared. *The British Accounting Review*, vol. 35, pp. 257-290.

Podsakoff, P.M., Organ, D.W. (1986). Self-reports in organizational research: problems and prospects. *Journal of Management*, Vol. 12 No.4, pp. 531-544.

Quinn, R. E., Rohrbaugh, J. (1981). A Competing Values Approach to Organizational Effectiveness, *Public Productivity Review*. Vol. 5, No. 2, pp. 122-140

- Radner, R. (1975). A behavioral model of cost reduction. *Bell Journal of Economics*, vol. 6, pp. 196-215.
- Raisch, S., Birkinshaw, J., Probst, G., Tushman, M. L. (2009). Balancing Exploitation and Exploration for Sustained Performance. *Organization Science*. Vol. 20, No. 4, pp. 685-695.
- Roberts, J. (2004). *The modern firm – organizational design for performance and growth*. Oxford University Press. New York, NY.
- Ross, P. F. (1974) Innovation Adoption by Organizations. *Personnel Psychology*, vol. 27, pp. 21-47.
- Sathe, V. (1983). The Controller's Role in Management, *Organizational Dynamics*, Winter, pp. 31-48
- Schermelleh-Engel, K., Moosbrugger, H., Muller, H. (2003). Evaluating the fit of structural equation models: tests of significance and descriptive goodness-of-fit measures. *Methods of Psychological Research Online*, Vol. 8 No. 2, pp. 23-74.
- Schäffer, U. (2007). *Management Accounting & Control Scales Handbook*. Deutscher Universitäts-Verlag: Wiesbaden.
- Shah, R., Ward, P. T. (2007). Defining and developing measures of lean production. *Journal of Operations Management*. Vol 25, pp. 785–805.
- Staats, B. R., Brunner, D. J., Upton, D. M. (2011). Lean principles, learning, and knowledge work: Evidence from a software services provider. *Journal of Operations Management*, vol. 29, pp. 376-390.
- Tillema, S., Steen, M. V. D. (2015) Co-existing concepts of management control – the containment of tensions due to the implementation of lean production. *Management Accounting Research*, vol. 27, pp. 67-83.
- Tucker, L. R., Lewis, C. (1973). A reliability coefficient for maximum likelihood

factor analysis. *Psychometrika*, Vol. 38, pp. 1-10.

Tushman, M. L., O'Reilly, C. A. (1996). Ambidextrous Organizations: managing evolutionary and revolutionary change. *California Management Review*, vol. 38. No. 4, pp. 8-30.

Turney, P. B. B., Stratton, A. J. (1992). Using ABC to support continuous improvement. *Management Accounting*. Vol. 73, No. 3, pp. 46-50.

Walton, R. E., Dutton, J. M. (1969). The management of interdepartmental conflict: A model and review. *Administrative Science Quarterly*. Vol. 14, pp. 73-84.

Widener, S. K. (2007). An empirical analysis of the levers of control framework. *Accounting, Organizations and Society*, vol. 32, pp. 757-788.

Womack, J. P., Jones, D. T. (2003). *Lean thinking: Banish waste and create wealth in your corporation*. Simon & Schuster: London, UK.

10. Paper 4: The performance effects of complementary management control mechanisms

Henrik Nielsen^a, Thomas Borup Kristensen^a, and Lawrence P. Grasso^b

^a*Department of Business and Management, Aalborg University*

^b*The Accounting Department, Central State Connecticut University*

Keywords: Complementarity, Management control mechanisms, Lean manufacturing, Second-order model, Firm performance

Abstract:

The main purpose of this paper is to explore complementarities among management control mechanisms (social, behavioral, and output control mechanisms) and their effects on performance in Lean manufacturing companies. We construct two competing hypotheses and test them in two structural equation models. We compare the additive performance effects of the management control mechanisms modeled as first-order factors with the performance effects of the management control mechanisms modeled as a complementary second-order factor capturing the multilateral interactions and the covariance among management control mechanisms. Utilizing a cross-sectional sample of 368 Lean manufacturing companies, we show that the complementary effects are superior to the additive effects of management control mechanisms. In fact, output control mechanisms and visual social control mechanisms are not additively related to performance.

10.1 Introduction

Interest in complementarity and in its role in the design of organizations has garnered increasing attention in the academic literature (Ennen & Richter, 2010). Practices that work together are considered to be complementary when doing more of one practice increases the marginal return of another practice and vice versa (Milgrom & Roberts, 1995). Lean manufacturing is an ideal setting in which to study complementarity (Furlan *et al.*, 2011) as it is recognized as an enterprise-wide management system consisting of interdependent practices (Roberts, 2004; Shah & Ward, 2007). Lean manufacturing was conceptualized by Krafcik and colleagues (1988), when studying Toyota as part of the MIT International Motor Vehicle Program, and it is generally accepted that Lean manufacturing improves firm performance (e.g., Fullerton & Wempe, 2009; Hofer *et al.*, 2012; Jayaram *et al.*, 2010; Maiga & Jacobs, 2008). However, both Shah and Ward (2003) and Furlan *et al.* (2010) suggest that it is the simultaneous, systematic implementation of several practices that contributes to firm performance through the complementary effects of these practices. This implies that the partial implementation of practices or of practices that do not work in concert will contribute to a lesser extent to firm performance.

The implementation of Lean manufacturing has been found to be associated with companies' management control mechanisms⁴⁶ (e.g., Åhlström & Karlsson, 1996; Fullerton *et al.*, 2013; Kristensen & Israelsen, 2014; Netland *et al.*, 2015), and it is recognized that management control mechanisms can either hinder or help Lean manufacturing implementations (Åhlström & Karlsson, 1996; Fullerton *et al.*, 2014). However, there is still much to understand about how management control

⁴⁶ We use the label "management control mechanisms" as Kennedy and Widener (2008) use this label. We believe that it is equivalent to the label "management control forms" used in other studies, e.g., Kristensen and Israelsen (2014).

mechanisms work in the Lean manufacturing context. In this study, we investigate the complementary effects of management control mechanisms⁴⁷ on firm performance in Lean manufacturing companies. As it is imperative that we examine these management control mechanisms from a holistic perspective (Ennen & Richter, 2010), we utilize the conceptual framework developed by Kennedy and Widener (2008), who extended the work of Ouchi (1978, 1979) and Snell (1992) to management control mechanisms in Lean manufacturing companies. Kennedy and Widener's framework (2008) views management control as interdependent mechanisms consisting of training, visualization, empowerment, peer pressure (social control mechanisms), standardization of practices and rules (behavioral control mechanisms), and performance measurements (output control mechanisms). We extend social management control mechanisms to also include Lean thinking (Emiliani *et al.*, 2003), as it is an important catalyst for successful Lean manufacturing implementation, and we increase the granularity of Kennedy and Widener's framework (2008) by distinguishing between social cultural control and social visual control mechanisms as well as between non-financial and financial control mechanisms.

Different strategies are used when testing for complementarity between organizational variables. Ennen and Richter (2010) describe two: the interaction strategy, focusing on the complementarity of two organizational variables, and the systems strategy, focusing on the complementarity of a broader set of variables. Using a sample of 368 American Lean manufacturing facilities, we adapt the systems strategy and follow the procedure developed by Tanriverdi and Venkatraman (2005). We develop and compare two competing structural equation

⁴⁷ Management control is defined by Anthony (1965, p. 17) as, "the process by which managers ensure that resources are obtained and used effectively and efficiently in the accomplishment of the organization's objectives."

models: The first model utilizes a second-order factor to capture multilateral interactions and covariance among the management control mechanisms as well as the effects of the second-order factor on firm performance. The second model conceptualizes the management control mechanisms as first-order factors and explores their additive effects on performance. We argue that this method for testing complementarity is superior to the different variants of regression analyses utilized in research on management control.

This study makes two major contributions to the small body of knowledge on this topic. First, we find that the performance effects of a complementary set of management control mechanisms are superior to their isolated additive effects. In fact, three of five management control mechanisms—visual social control mechanisms, financial output control mechanisms, and non-financial output control mechanisms—do not additively contribute to firm performance. Second, our study is the first to provide empirical support from a large sample of firms suggesting that the full set of Lean management control mechanisms is complementary. Moreover, we provide detailed descriptions of how Lean management control mechanisms work together in order to facilitate a deeper understanding of the complementarity effects on firm performance. We are especially motivated by Fullerton *et al.* (2013), who call for an extension of their study to encompass all the management control mechanisms from the Kennedy and Widener (2008) framework, and by Malmi and Brown (2008), who welcome research on more specified management control mechanisms.

The remainder of this paper is organized as follows: In Section 2, we describe the literature and develop our two competing hypotheses. In Section 3, we present our sample and methods and, in Section 4, we present our results. We discuss and

conclude the paper in Section 5. Limitations and recommendations for future research are presented in Section 6.

10.2 Literature and hypotheses development

It is well established that Lean manufacturing is positively associated with firm performance (e.g., Hofer *et al.*, 2012; Fullerton *et al.*, 2014; Khanchanapong *et al.*, 2014; Maiga & Jacobs, 2008). Hence, the focus here is not on whether Lean manufacturing can benefit performance but rather on how management control mechanisms assist Lean manufacturing companies in achieving improved firm performance. Management control mechanisms have garnered attention in the Lean manufacturing literature (e.g., Fullerton *et al.*, 2013; Netland *et al.*, 2015) and have been conceptualized as consisting of social, behavioral, and output controls (Kennedy & Widener, 2008). Research has found that Lean manufacturing is related to these management control mechanisms. For example, Lean manufacturing has been found to be related to visualization (Banker *et al.*, 1993), peer pressure (Ezzamel & Willmott, 1998), employee empowerment (Lind, 2001), and training (Woolson & Husar, 1998). Lean manufacturing has also been found to be related to standard operating procedures (Rondeau *et al.*, 2000) and rules (Shah & Ward, 2003). Evidence also suggests that Lean manufacturing relies on non-financial performance measurements (Banker *et al.*, 1993) and financial performance measurements (Emiliani *et al.*, 2003). Table 1 depicts the management control mechanisms used in this study. These are drawn from Kennedy and Widener's (2008) framework, but we increase the granularity of the framework as we distinguish non-financial control mechanisms from financial control mechanisms as well as social cultural control mechanisms from social visual control mechanisms.

Table 1: Lean management control mechanisms

Social controls		Behavioral controls	Output controls	
Social cultural controls	Social visual controls	Standard operating procedures	Non-financial output controls	Financial output controls
Employee empowerment	Visualization	Rules	Non-financial performance measurements	Financial performance measurements
Peer pressure				
Training				
Lean thinking				

Empirical research suggests that Lean management control mechanisms are interrelated, but there is limited evidence of their complementarity. For example, in their case study of a Lean manufacturing company, Kennedy and Widener (2008) found that social, behavioral, and output controls were interrelated, meaning that, for example, performance measurements (output control mechanism) went hand in hand with employee empowerment (a social control mechanism), and standard operating procedures (behavioral control mechanism), similarly, went hand in hand with visualization (social control mechanism). Kristensen and Israelsen (2014) studied balance among social control mechanisms, behavioral control mechanisms, and output control mechanisms in a single firm. Their results indicated that greater balance led to greater firm performance, and they argued that the results were evidence of complementarity. However, their methodology made it difficult to capture patterns of interactions and covariance among the Lean control mechanisms because the control mechanisms were collapsed into two aggregate measures. Without using the management control mechanism terminology, Emiliani *et al.* (2003) found that social, behavioral, and output controls were interrelated in a Lean manufacturing company. Emiliani *et al.* (2003), Kennedy and Widener (2008), and Kristensen and Israelsen (2014) were single firm studies, which makes their findings difficult to generalize. Furthermore, Emiliani *et al.* (2003) and Kennedy and Widener (2008) did not study the complementary effects

of the management control mechanisms on firm performance. In a cross-sectional study, Fullerton *et al.* (2013) investigated fragmented parts of the Lean management control mechanisms. They found that employee empowerment (social control mechanism) and visual performance information (output control mechanism) were interrelated. Fullerton *et al.* (2013) did not study complementary effects on performance, and their reductionist method is problematic when studying complementarity (Ennen & Richter, 2010).

To establish clear evidence of complementarity among Lean management control mechanisms, firm performance effects stemming from individual management control mechanisms must be compared with performance effects stemming from complementarity of the complete set of management control mechanisms (Tanriverdi & Venkatraman, 2005). Furthermore, a detailed exploration of how the interrelatedness and complementarity of management control mechanisms can support Lean manufacturing companies (Maskell *et al.*, 2012) is needed in a cross-sectional setting (Kennedy & Widener, 2008). As we will explain in the sections below, we expect that Lean management control mechanisms are complementary and that the complementary effects on firm performance are greater than the additive effects from management control mechanisms. We follow the same argumentation logic and structure as Tanriverdi and Venkatraman (2005). First, in Sections 2.1-2.3, we describe Lean management control mechanisms and explain how management control mechanisms are interrelated; second, in Section 2.4, we develop our hypotheses and describe how we expect complementarity to exist between management control mechanisms.

2.1 Social control mechanisms

According to Kennedy and Widener (2008), social control mechanisms in Lean manufacturing companies encompass visualization, peer pressure, training, and employee empowerment. Visualization is essential in Lean manufacturing companies (Belekoukias *et al.*, 2014; Cunningham & Fiume, 2003), and it goes hand in hand with both behavioral and output control mechanisms. Boards are used in the manufacturing area to visualize the current and future state of operations (a non-financial output control mechanism) and to show standard operating procedures (a behavioral control mechanism). Boards also show whether current activities are deviating from standards (Emiliani *et al.*, 2003) and provide real-time, easy-to-understand performance metrics that direct employees' attention to potential improvement areas and manufacturing related problems, ensuring that production objectives are aligned with the Lean strategy (Liker, 2004). Training matrices and employee capabilities indicators are used to highlight the skills required for working in a manufacturing cell and to show the current skills for each individual employee working in that cell (Kennedy & Widener, 2008; Maskell *et al.*, 2012). This assists employees during the planning of their work activities. However, visualization goes beyond informing employees about standards, improvement potential, performance, and skills: Visualization also includes a structuring of the entire manufacturing area with high visibility, which should allow employees to assist one another between work processes and to help them understand how their own work activities are related to other areas of the facility (Liker, 2004). This can be referred to as global transparency (Adler & Borys, 1996). Global transparency reduces the risk of sub-optimization and enables employees to identify problems and improvement potentials in other manufacturing cells than their own.

For visualization to be effective, employees in Lean manufacturing companies must be trained in Lean principles (Fullerton *et al.*, 2013) such as kaizen, standard operating procedures, and creativity. Employees not trained in Lean principles will not be able to fully grasp, act, and react to the information on the boards or to use this information to solve problems and identify potential improvement areas. The Lean training can be done onsite, e.g., by employees continuously going to the gemba and figuring out solutions or improvements (Farris *et al.*, 2009). Employees are motivated to undergo training, as cell capability indicators highlight whether they are experts in a certain skill (Kennedy & Widener, 2008). The training also facilitates the empowerment of employees responsible for quality, cost, and flow, enabling them to make timely and effective decisions and adjustments to their work (Cua *et al.*, 2001; Fullerton *et al.*, 2013). This is especially important in Lean manufacturing companies with reduced buffer inventories, as potential breakdowns have severe effects downstream (Callen *et al.*, 2005; Kristensen & Israelsen, 2014). Additionally, the empowerment of employees enables them to carry out experiments and perform continuous improvement, potentially improving their own and others' work processes. This, of course, is not something that happens without employees being motivated or being encouraged to do so. A possible motivational element is that Lean thinking permeates the minds of employees and managers. Lean thinking enables them to think, act, and behave with a passion for Lean manufacturing (Wood *et al.*, 2015), and it therefore functions as an internal motivational factor (Bhamu & Sangwan, 2014). Here we extend Kennedy and Widener's framework (2008), inspired by clan controls⁴⁸ (Ouchi, 1979). Peer pressure is another catalyst for employees to solve problems, identify improvement potentials, and undergo additional training (Kennedy & Widener, 2008). Peer

⁴⁸ Ouchi (1979, pp. 837) states that some of the characteristics of clan controls are to ensure that employees try to achieve the "right" objectives.

pressure in Lean manufacturing companies can occur when employees at the same hierarchical level mutually reinforce their desire to obtain additional knowledge, work skills, and higher performance, both in comparison to other employees in the manufacturing cell as well as in comparison to other manufacturing cells and value streams. The monitoring and highlighting of skills and performance within and between manufacturing cells (a non-financial output control mechanism) can lead to a sense of pride among employees and can improve motivation (Kennedy & Widener, 2008). We have decided to distinguish between social cultural control mechanisms and social visual control mechanisms, because the former is input oriented, intended to affect behavior *ex ante*, whereas the latter is process oriented, intended to guide immediate behavior.

2.2 Behavioral Control Mechanisms

Behavioral control mechanisms in Lean manufacturing companies consist of standard operating procedures and rules (Kennedy & Widener, 2008). These are seen as an aid to help employees reach the desired output, both in terms of levels output and quality and in terms of the best practice in reaching that output (Secchi & Camuffo, 2016). They are not seen as strict instructions from which deviations are not acceptable but as systematic descriptions of value-added and non-value-added activities that enable employees to perform continuous improvement (Adler & Borys, 1996; Kristensen & Israelsen, 2014). In fact, without standard operating procedures, continuous improvement becomes impossible, as any improvement will be just another variation of the work processes (Liker, 2004). Standard operating procedures are updated to incorporate proven improvements, or they are changed in response to changes in demand or other contingencies (Ahrens & Chapman, 2004). For example, a cell may optimize standard operating procedures

affecting other production cells, or changes in market conditions may require manufacturing cells to perform activities differently to meet customer demand.

Standard operating procedures go hand in hand with social control mechanisms, described in Section 2.1. For example, standard operating procedures are visualized (a social visual control mechanism) to employees: pictures of the assembly of parts are made visible on boards in a manufacturing cell, floor markings indicate the flow of materials and finished goods (Kennedy & Widener, 2008), and visual controls indicate whether or not work-in-progress levels are under control (Kristensen & Israelsen, 2014). Furthermore, employees in Lean manufacturing companies undergo training (a social cultural control mechanism) that enables them to understand, perform, and challenge the standard operating procedures (Liker, 2004).

Standard operating procedures work together with non-financial output control mechanisms as well. For example, whiteboards are used in the manufacturing cells to post numbers showing the ability to deliver on time, indicating how well employees are performing. This operating information is used in concert with standard operating procedures to help employees determine whether corrective actions are needed (Kristensen & Israelsen, 2014). The corrective action may adjust current activities, but it may also involve changing and improving the standard operating procedure.

Behavioral controls go beyond standard operating procedures. For example, the Kanban system ensures the replenishment of materials (Shah & Ward, 2007). It includes paper cards that are utilized to pull the right materials to the right places, in the quantities needed, when needed (Emiliani *et al.*, 2003). This demands standards for quantities, materials, procedures for internal customers, and the exact

point for when to pull additional materials. One-piece flow and the use of line balancing and level schedules (heijunka) are behavioral controls as well. Optimally, one-piece flow ensures that a part moves to the next operation only when the prior operation is successfully completed (Emiliani *et al.*, 2003). In essence, one-piece flow is then a rule that demands that products are produced only as needed; for this to happen, companies need standard operating procedures that document the sequence of operator work, machine work, and operator movement that is required to produce one unit of a product or part (Miltenberg, 2001). Likewise, line balancing and level schedules demand close relationships with suppliers (Chavez *et al.*, 2015) and standards for production planning and the delivery of products in order to reduce fluctuations in demand and output (Liker, 2004).

2.3 Output control mechanisms

Output control mechanisms consist of performance measurement systems (Kennedy & Widener, 2008). Lean manufacturing companies use detailed non-financial performance measurements to facilitate real-time analyses of cell performance (Fullerton *et al.*, 2014). These measurements track different kinds of cell performance, such as day-by-the-hour, first time through, work-in-progress to standard work-in-progress, and operational equipment effectiveness (Maskell *et al.*, 2012), and they provide fast feedback when problems arise (Banker *et al.*, 1993). These measurements also include past, current, and desired performances, which are supposed to function as motivators for employees and to direct attention to issues that need to be solved. Although different non-financial performance measures are used, this applies for value streams and the facility as well (Emiliani *et al.*, 2003; Maskell *et al.*, 2012). Besides tracking performance and providing feedback, the main purposes of these non-financial performance measures are to align behavior with Lean manufacturing objectives (Liker, 2004). This is done in

close relationship with social visual control mechanisms, as non-financial performance measures are visually displayed throughout the facility. For example, recurring problems are highlighted on visual boards to initiate kaizens (Emiliani *et al.*, 2003) and to enhance peer pressure in teams (a social cultural control mechanism). These non-financial performance measurements work together with the financial performance measurements presented in quarterly and annual reports (Liker, 2004). Financial performance measurements are also necessary to assist managers and employees in stimulating communication, sending signals related to strategic issues, and fostering learning throughout the organization (Henri, 2006). It is important to distinguish between Lean non-financial and financial output control mechanisms, as they are inherently different. Financial output controls typically lag non-financial output controls, because many of the non-financial output controls are measurement drivers of future financial results (Johnson, 1992).

2.4 Hypothesis development

The previous sections described Lean management control mechanisms and clarified their interrelatedness. We expect that this interrelatedness will cause complementary effects on firm performance in that the benefits from any Lean management control mechanism are greater when the mechanism is accompanied and integrated with the other Lean management control mechanisms (Roberts, 2004). For example, performance measurement systems (output control mechanisms) drive behavior to a greater extent and are more likely to direct employees' attention to problems if they are visualized through social controls. The effect of peer pressure (a social control mechanism) will be higher if boards containing skill matrices are visualized (an output control mechanism) to other employees. Standard operating procedures (a behavioral control mechanism) may be tacit knowledge for employees, but they are more effective if they are visualized,

ensuring that all employees work according to the best standard currently known. The visualization of standards also enables employees to challenge and improve these standards. Additionally, the effectiveness of standard operating procedures will likely be higher if all employees are trained according to these standards (social control mechanism).

When complementarities exist among management control mechanisms, a firm needs to coordinate the use of these management control mechanisms by implementing them simultaneously. Thus, we follow the same procedure as Tanriverdi and Venkatraman (2005) and develop a latent second-order construct. The first level of this construct captures the sub-additive effects arising from social, behavioral, and output control mechanisms, and the second level captures the super-additive effects from the complementarity of management control mechanisms. When assessing the performance effects of a complementary system of management control mechanisms, we have to compare the performance effects of individual management control mechanisms with the performance effects of the complementarity among management control mechanisms, and we have to ensure that the complementarity performance effects outweigh the individual effects (Tanriverdi & Venkatraman, 2005; see also Ichniowski *et al.*, 1997, and Whittington *et al.*, 1999). Following Tanriverdi and Venkatraman's procedure (2005), we develop two competing hypotheses to test whether the performance effects of management control mechanisms in Lean manufacturing companies are contingent on the complementarity of these management control mechanisms or whether the individual management control mechanism has an independent direct effect on performance: (1) a "strong form," stating that the complementarity of management control mechanisms will have a direct positive effect on firm

performance, and (2) a "weak form," stating that each management control mechanism will have an independent direct positive effect on firm performance.

H1 (strong form): The complementarity of social control mechanisms, behavioral control mechanisms, and output control mechanisms has a positive effect on firm performance.

H2 (weak form): Social control mechanisms, behavioral control mechanisms, and output control mechanisms have independent positive effects on firm performance.

Figure 1 includes a conceptual model of the complementarity hypothesis (H1).

Figure 1: Complementary hypothesis (H1)

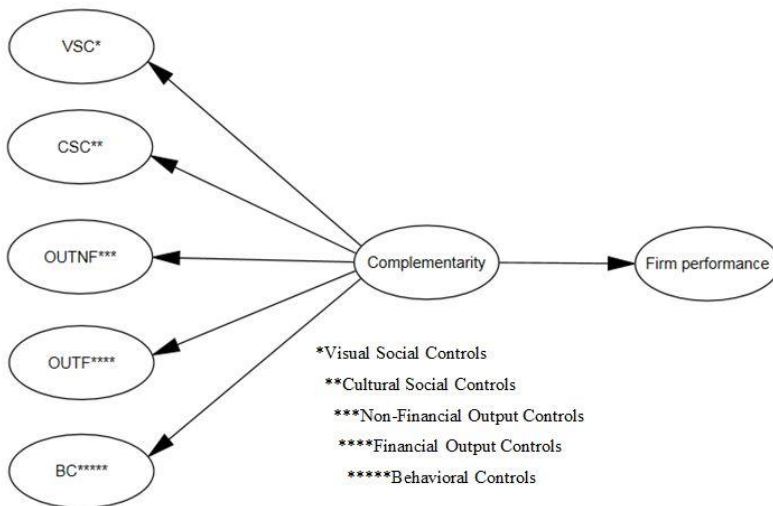

10.3 Methods

The survey was distributed online to 4,357 subjects, representing 697 manufacturing facilities, in September 2012, and responses were received until

December 2012. The subjects were identified from the Shingo Prize⁴⁹ Organization database of individuals who had expressed an interest in receiving information about Lean principles, Shingo seminars and workshops, and the Shingo Prize. We received responses from 510 individuals, representing 368 different facilities, yielding a response rate of 11.70% which is similar to other research papers on Lean manufacturing (e.g. Hofer *et al.*, 2012; Shah & Ward, 2003). We averaged responses from plants from which we received multiple responses, leaving us with a usable sample size of 368 and a facility response rate of 52.8%. Collectively, the 368 facilities represented 195 different organizations. 30% of the organizations produced vehicles or provided components to the automotive industry, 29% produced healthcare related products, 23% made products for the aerospace industry, and 19% produced components for the department of defense.

Of the facilities, 52% had more than 500 employees and 53% of the facilities had sales of over \$100M. The average management experience of the respondents within their current firms was 11.3 years. This is important to our study, as experienced managers are likely to understand our holistic set of questions regarding management control, Lean manufacturing, and performance in their facilities⁵⁰. Of the respondents, 53.5% were responsible for Lean, quality, or continuous improvement. Survey questions were intended to assess the level of

⁴⁹ The Shingo Prize is an award given to companies based on their world-class results and organizational culture. The database includes many companies, as most organizations do not wait to challenge for the Shingo Prize until they are likely to win it.

⁵⁰ As the large majority of respondents had management experience and were responsible for Lean at their facility, our constructs might be subject to common method bias. To reduce these concerns, we perform a Harman's one factor test including all our latent variables. There is a potential bias if the majority of the variance is explained by one factor (Podsakoff and Organ, 1986). The test shows that the concern for common method bias is low, as a one factor solution only accounts for 45% of the total variance.

Lean manufacturing and management control implementation at the respondents' facilities as well as to obtain a self-assessment of firm performance.

In the following sections, we describe how we developed our variables. We also go through our statistical tests and explain why we decided to utilize Tanriverdi and Venkatraman's (2005) test for complementarity. Figure 2 illustrates the sequence of the statistical tests.

Figure 2: Sequence of statistical tests

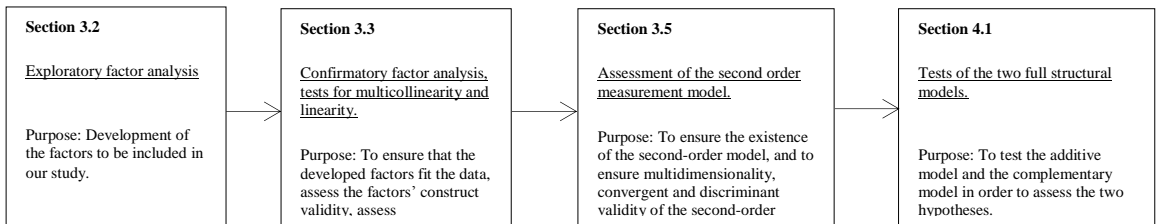

10.3.1 Measures

Although the questionnaire included 148 questions, we only included a portion for analysis in the present article. We drew upon Kennedy and Widener (2008) in developing most management control mechanism items, and we adapted several items from Fullerton *et al.* (2013; 2014). We developed four items covering cultural social control mechanisms, intended to cover the degree to which the entire facility is trained in Lean principles (CLTR 4), employee empowerment (CLTR 3 and CLTR 1), and peer pressure (CLTR 8). Furthermore, we developed three additional items, CLTR 5, CLTR 6, and CLTR 7, intended to capture the degree to which the facilities work with continuous improvement, the degree to which management is focused on eliminating waste, and the degree to which Lean thinking has permeated all operations, respectively. CLTR 2 was adapted from

Fullerton *et al.* (2013) and was intended to cover the degree to which management is committed to quality-related training. Of the seven items covering visual social control mechanisms, MAS 2, MAS 4, MAS 5, and MAS 7 were adapted from Fullerton *et al.* (2013), while the remaining three items were developed in accordance with Kennedy and Widener (2008). All items were intended to capture the degrees of different types of visualization.

Three of four items covering behavioral control mechanisms were adapted from Fullerton *et al.* (2013) and were intended to cover the degree of facilities' use of standardization of manufacturing procedures (MFG 1), a Kanban system (MFG 2), and one-piece flow (MFG 3), and we developed MFG 4 to capture the use of line balancing and level schedules.

The three items covering non-financial output controls were intended to capture the importance of non-financial performance measures related to cell performance (PRF 1), value stream performance (PRF 2), and facility performance (PRF 3). As these measures are rather generic, we follow the same procedure as Fullerton *et al.* (2013) and include a test for criterion validity where we correlate our non-financial output controls with criterion variables in order to demonstrate plausibility. This test can be found in Appendix 1, table 1. We developed four additional items covering financial output control mechanisms, intended to capture the importance of performance measures related to market share (PRF 4), cash flow (PRF 5), overall financial results (PRF 6), and customer satisfaction (PRF 7). One of the six items covering performance (LIMP 3) was adapted from Fullerton *et al.* (2014), while we developed the remaining items in order to cover the extent to which Lean initiatives have freed inventory resources (LIMP 1), improved capacity management effectiveness (LIMP 2), improved quality (LIMP 4), improved communication (LIMP5), reduced costs (LIMP 6), and improved profitability

(LIMP 7). Thus, our performance items cover both a goal-centered and an accounting approach (Kihn, 2005). Survey items can be found in Appendix 1, table 2.

All items were measured on a 5-point labeled Likert scale. Eustler and Lang (2015) have shown that labeled scales are superior to unlabeled scales as they reduce measurement error and response bias.

10.3.2 Exploratory factor analysis

We conducted an exploratory factor analysis including our exogenous variables with oblique rotation. We removed one item that loaded greater than .4 on more than one variable⁵¹. After the removal of one item, we conducted another exploratory factor analysis, which yielded five factors with eigenvalues greater than one, collectively explaining 66.8% of the variance: cultural social controls, visual social controls, behavioral controls, non-financial output controls, and financial output controls. Additionally, we performed an exploratory factor analysis for the performance items yielding one factor with an eigenvalue greater than one, explaining 65.5% of the variance. Along with the exogenous factors, the performance factor represents the variables used in this study (see Table 2). All factors' Cronbach's alphas are between .786 and .913 (see Table 3), demonstrating good to excellent reliability (Kline, 2011).

⁵¹ The .4 cut-off have been used in prior research on Lean manufacturing (e.g., Fullerton & Wempe, 2009; Fullerton *et al.*, 2014). The removal of one item did not affect the composition of the five factors.

Table 2: Exploratory factor analysis and descriptive statistics

Factor	Cultural social controls	Visual social controls	Non-fin. controls	output	Financial controls	output	Behavioral controls	Firm performance	Mean	Std. deviation
<i>Indicator</i>										
CLTR1	.585								3.49	.99
CLTR2	.517								3.84	.83
CLTR3	.707								3.33	.95
CLTR4	.568								3.33	.79
CLTR5	.727								3.42	1.07
CLTR6	.851								3.44	1.05
CLTR7	.755								3.50	1.01
CLTR8	.766								3.18	1.08
MAS1		-.629							3.68	.94
MAS2		-.651							4.08	.87
MAS3		-.724							3.35	1.15
MAS4		-.849							3.72	1.06
MAS5		-.745							3.39	1.04
MAS6		-.854							3.67	1.08
MAS7		-.745							3.37	1.14
PRF1			-.851						3.18	1.10
PRF2			-.790						3.02	1.13
PRF3			-.852						3.18	1.05
PRF4					.825				3.43	1.17
PRF5					.869				3.72	1.13
PRF6					.749				4.17	.87
PRF7					.509				4.19	.89
MFG1							-.413		3.86	.82
MFG2							-.727		3.52	1.06
MFG3							-.719		3.27	1.11
MFG4							-.779		3.50	1.06
LIMP1								.754	3.24	.95
LIMP2								.850	3.59	.86
LIMP3								.848	3.72	.87
LIMP4								.785	3.64	.86
LIMP5								.768	3.62	.84
LIMP6								.828	3.60	.89
LIMP7								.829	3.53	.90

KMO of sampling adequacy for the management control mechanism factors: .944, Bartlett's Test of Sphericity is significant $p < .000$.

KMO of sampling adequacy for the firm performance factor .887, Bartlett's Test of Sphericity is significant $p < .000$.

The KMO values above .5 and the significance of the Bartlett's Test of Sphericity indicates that the data is suitable for exploratory factor analysis, and that there are patterns among items (Field, 2005).

Only loadings exceeding .400 are shown.

10.3.3 Confirmatory factor analysis

We perform a confirmatory factor analysis in AMOS 23 including our factors, using maximum likelihood estimation. This is a two-step procedure where the measurement model without structural paths is evaluated to ensure that it fits, and this is followed by an evaluation of the entire structural model (Hair *et al.*, 2014). We evaluate the measurement model using several fit indices, as recommended by Kline (2011). We assess χ^2 to degrees of freedom (Bollen, 1989), as it seems to be the consensus in the SEM literature, although Kline (2011) states that there is little statistical and logical foundation for using this measure of model fit. We assess the root mean square error of approximation (RMSEA) and the standardized root mean square residual (SRMR). Additionally, we evaluate the comparative fit index (CFI) (Bentler, 1990), incremental fit index (IFI) (Bollen, 1989), and Tucker-Lewis index (TLI) (Tucker & Lewis, 1973). In general, there are no accepted minimal thresholds for what constitutes acceptable model fit (Schermelleh-Engel *et al.*, 2003). However, there are suggested parameters in published academic work for what would represent acceptable fit: χ^2 to degrees of freedom should be less than three, indicating acceptable fit (Kline, 2005); a RMSEA value below .08 would indicate acceptable fit (Browne & Cudeck, 1993; Kline, 2011); a SRMR value below .1 indicates acceptable fit (Schermelleh-Engel *et al.*, 2003); and CFI, IFI, and TLI are evaluated for their closeness to 1.0 (Byrne, 2010) with values over .9 (Bentler, 1992; Kline, 2005), indicating acceptable fit. Lastly, we evaluate the Consistent Akaike's Information Criterion (CAIC), addressing the issue of

parsimony in the assessment of model fit, taking sample size into account (Bozdogan, 1987), where the ratio of the hypothesized model and the saturated model should be less than one (Byrne, 2010). Although the χ^2 is significant ($p < .001$), the χ^2 to degrees of freedom is less than three, and fit indices are more than acceptable (see Table 3).

Table 3: Confirmatory factor analysis, composite reliability, and Cronbach's alpha

Factor indicators	Standardized loadings	T-value (All significant $p < .01$)	C.R.	Alpha
<i>Cultural social controls</i>			.908	.904
CLTR1	.71	a		
CLTR2	.62	11.58		
CLTR3	.71	13.22		
CLTR4	.50	10.23		
CLTR5	.76	14.01		
CLTR6	.82	15.24		
CLTR7	.83	15.41		
CLTR8	.88	16.32		
<i>Visual social controls</i>			.912	.909
MAS1	.70	13.71		
MAS2	.78	15.44		
MAS3	.73	14.31		
MAS4	.83	16.52		
MAS5	.80	15.82		
MAS6	.81	16.15		
MAS7	.76	a		
<i>Behavior controls</i>			.826	.821
MFG1	.65	a		
MFG2	.75	11.84		
MFG3	.78	12.19		
MFG4	.77	12.17		
<i>Non-fin. output controls</i>			.913	.913
PRF1	.89	a		
PRF2	.90	24.24		
PRF3	.86	22.39		
<i>Financial output controls</i>			.805	.797

PRF4	.75	a		
PRF5	.77	12.90		
PRF6	.70	12.03		
PRF7	.62	10.86		
<i>Firm performance</i>			.913	.912
LIMP1	.72	a		
LIMP2	.82	15.56		
LIMP3	.83	15.82		
LIMP4	.75	14.07		
LIMP5	.79	14.96		
LIMP6	.78	14.79		
LIMP7	.72	13.50		

χ^2 to degrees of freedom: 2.299, RMSEA: .060, SRMR: .054, IFI: .923, TLI: .915, CFI: .922, CAIC: .429 (1663.439/3875.435 saturated model).

To assess construct validity, we investigate the factors' convergent validity, construct reliability, and discriminant validity. All our factors show good convergent validity, as their average variance extracted (AVE) is above .5 (see Table 4) and their construct reliability (CR) is well above .7 (Hair *et al.*, 2014). Furthermore, as indicated in Table 3, all factor loadings (standardized coefficients) are above .5 (Bagozzi & Yi, 1988). Discriminant validity is assessed by comparing the square root of the AVE of the factors with their correlation (Fornell & Larcker, 1981), where the square root AVE of individual factors should be greater than the interfactor correlation. Square root AVE of factors is indicated at the diagonal of Table 4 and is greater than the interfactor correlations⁵². Additionally, none of the

⁵² Squared AVE to inter-factor correlations is computed in SPSS 23. We compared the squared AVE to the inter-factor correlations in AMOS 23 as well. This test revealed discriminant validity issues only concerning the performance factor, the social controls 1 factor, and the behavioral controls factor. All of our factors correlated less than .85, not indicating poor discriminant validity (Kenny, 2012). Kenny (2012) also suggests restricting the correlation between two factors to 1, which is similar to collapsing the two factors (Hair *et al.*, 2014). This is done to investigate if a one-factor model is more appropriate than a two-factor model. A two-factor model is appropriate if χ^2/df^{Diff} is significant (Hair *et al.*, 2014). We performed a test in AMOS 23 where we constrained correlations between both

interfactor correlations exceed their alphas, which is another indicator of discriminant validity (Crocker & Algina, 1986). Table 4 also indicates that all factors correlated significantly. Our measurement model did not indicate multicollinearity issues, as none of the variance inflation factors exceeded 2.8, and all tolerance statistics exceeded .36.

Before running the two full structural models, we also test all relationships from exogenous variables to performance for linearity. All relationships are significantly linear $p < .01$ and have R^2 values ranging from .146 to .656 and F-values between 62.658 and 697.191. In addition, the number of free parameters to be estimated compared with the sample size is well above the minimum ratio of 1:5 recommended by Worthington and Whittaker (2006) in both the first-order structural model and the second-order structural model.

the performance factor and behavioral controls and the performance factor and social controls 1. In both instances, a two-factor model fitted the data significantly better: restricting the correlation to one between performance and behavioral controls yields a χ^2 of 1199.22 and degrees of freedom: 482, resulting in a significant χ^2/df^{Diff} ($p < .01$) and the following fit indices: RMSEA: .064, SRMR: .1307, IFI: .911, TLI: .902, and CFI: .911. Restricting the correlation to one between performance and social controls 1, on the other hand, yields a χ^2 of 1143.806 and degrees of freedom: 482, resulting in a significant χ^2/df^{Diff} ($p < .01$) and the following fit indices: RMSEA: .061, SRMR: .0748, IFI: .918, TLI: .910, and CFI: .918.

Table 4: Factor correlations, squared average variance extracted and average variance extracted

Factor	# of measures	1	2	3	4	5	6	AVE
Non-financial output controls	3	.883						.779
Visual social controls	7	.620**	.773					.598
Cultural social controls	8	.667**	.678**	.739				.547
Behavioral controls	4	.528**	.607**	.609**	.738			.544
Financial output controls	4	.411**	.447**	.428**	.475**	.713		.508
Firm performance	7	.627**	.674**	.762**	.718**	.491**	.774	.600

** significant at the $p < .01$ level.

All measures are a labeled Likert scale from 1–5.

Square roots of AVE are shown at the diagonal.

10.3.4 Testing for complementarity

There are several strategies when testing for complementarities in research. Ennen and Richter (2010) divide these strategies into two main categories: the interaction approach and the systems approach. The interaction approach is of a reductionist character (Drazin & Van de Ven, 1985), as it only includes pairs of interactions and their main effects in a regression model. This is often a function of statistical necessity, as individual variables in complementary systems are heavily correlated and, furthermore, heavily correlated with the interaction term. When the main variables and their pair-wise interaction terms are heavily correlated, coefficient estimates obtained from the regression model do not reflect the inherent effects of any particular independent variable on the dependent variable but only the marginal effects or the partial effects, given the other, independent variables in the model (Tanriverdi & Venkatraman, 2005). Our independent variables are significantly correlated, as shown in Table 4. Likewise, our multiplicative interaction terms are heavily correlated with each other and with their main

variables (correlations ranging from .311 $p < .001$ to .935 $p < .001$)⁵³. Furthermore, by focusing only on pairs of interactions, researchers that are not able to detect the expected complementarity between two variables might overlook that the expected complementarity is a function of a third variable (Ennen & Richter, 2010). Our theory concerns complementarities among multiple variables. Given the theoretical development and explanations leading to our complementarity hypothesis, the interpretational problems inherent in the interaction approach render it an ineffective means of testing the hypothesis.

The systems strategy testing complementarity involves focusing on a holistic set of variables (Ennen & Richter, 2010). However, Ennen and Richter (2010) do not elaborate on the statistical testing techniques of this strategy. Profile deviation analysis is suggested by Gerdin and Greve (2004). Studies that use profile deviation analysis segment data based on a criterion variable and find the ideal state of systems within each of these segments (see, e.g., Hult *et al.*, 2007). As a second step, researchers use the city block distance or the Euclidian distance, expecting that the deviations from the ideal state are negatively associated with performance. However, the city-block distance only accounts for additive effects, and it is unclear exactly what is captured by the Euclidian distance. Another possibility when pursuing systems strategy is to apply higher-order interactions in a regression model. However, this approach will increase the correlations between individual variables and their multiplicative interactions, leading to interpretational problems of the regression model (Tanriverdi & Venkatraman, 2005). Other studies that apply the systems strategy attempt to capture the nature of organizational systems by using a categorical variable that studies whether or not a particular

⁵³ We computed the main variables and their pair-wise interactions and correlated them in SPSS 23.

factor is in place (e.g., Furlan *et al.*, 2011). However, this approach provides little information on the nature of the relationships that drive the complementarity effects observed (Ennen & Richter, 2010).

As the tests described here were not appropriate for testing our hypotheses on complementarity, we sought an alternative statistical method and decided to utilize the approach applied by Tanriverdi and Venkatraman (2005). Tanriverdi and Venkatraman (2005) constructed two models in order to test for complementarity: a first-order model to capture the sub-additive effects of their variables on performance and a second-order factor model to account for the multilateral interactions and covariance among their variables, in order to test for complementary effects on performance. A second-order factor is an entity that is reflected by first-order factors serving as its indicators (Williams *et al.*, 2004) and is the main source of covariance among first-order factors; it explains why the first-order factors coexist and co-vary with each other (Rindskopf & Rose, 1988). Utilizing Tanriverdi and Venkatraman's (2005) procedure, we avoid the interpretational challenges of the other tests for complementarity of multiple variables (in our case, control mechanisms), and we can compare the additive effects on firm performance with the complementary effects on firm performance. We are thus able to test both our hypotheses and to determine whether the complementary effects outweigh the additive effects as well as whether some of the management control mechanisms affect firm performance in isolation.

10.3.5 Assessment of the second-order measurement model

Following Tanriverdi and Venkatraman's procedure (2005)⁵⁴, we need to compare the first-order measurement model where we correlate our management control mechanisms with the second-order measurement model in order to assess the existence of a second-order model and to ensure the multidimensionality, construct, and convergent validity of the second-order model. Marsh and Hocevar (1985) developed the target coefficient statistic, which is the ratio of the chi-square of the first-order model to the chi-square of the second-order model. The target coefficient has an upper limit of 1.0 (Tanriverdi & Venkatraman, 2005), and support for the existence of a second-order factor becomes stronger when the target coefficient approaches unity (Marsh & Hocevar, 1985). The value of the target coefficient of our second-order complementarity factor is .98, indicating that a second-order factor explains 98 percent of the relations among the first-order factors. Furthermore, all second-order factor loadings are highly significant ($p < .001$), providing further acceptance of a second-order model. Collectively, these results support the existence, multidimensionality, convergent and discriminant validity, and reliability of a second-order complementarity construct (Tanriverdi & Venkatraman, 2005) (see Table 5).

⁵⁴ Following Tanriverdi and Venkatraman's (2005) procedure, we did not include the performance variable in this test.

Table 5: Panel A: Fit indices for the first-order measurement model and the second-order measurement model

Fit indice	First-order measurement model	Second-order measurement model
X2	605.899	617.845
Degrees of freedom	289	294
X2 to degrees of freedom	2.097	2.012
IFI	.946	.945
TLI	.939	.938
CFI	.946	.944
RMSEA	.055	.055
SRMR	.056	.058
CAIC (default model to saturated model)	.422	.422
Target statistic:	.980	
(605.899/617.845)		

Panel B: First-order factor loadings on complementary factor

Relationships			Standardized coefficient	T-values (all significant at p<.001)
Non-financial output controls	<--	Complementarity factor	.806	9.815
Visual social controls	<--	Complementarity factor	.844	9.060
Cultural social controls	<--	Complementarity factor	.866	10.101
Behavioral controls	<--	Complementarity factor	.793	a*
Financial output controls	<--	Complementarity factor	.549	7.205

* Indicates a loading fixed to 1.

10.4 Empirical tests and results

10.4.1 Test of hypotheses

The figures below depict the models of our two competing hypotheses. Figure 3 shows a graphical representation of the model for testing Hypothesis 1. This depicts our management control mechanisms modeled initially as first-order factors. The second-order factor in the figure models the complementarity among our management control mechanisms by accounting for their covariance and multilateral interactions, and the directions of the structural links are from the second-order factor to the first-order factor, indicating that all the management

control mechanisms are adapted simultaneously and systematically. In order to test our hypothesis, the second-order factor is related to firm performance. Figure 4 shows a graphical representation for testing Hypothesis 2. It shows the management control mechanisms as first-order factors, models their pair-wise covariance, and relates the management control factors additively to firm performance. In Figure 3, the structural parameter from the complementarity second-order factor to firm performance is positive and significant (standardized β coefficient: .927, $p < .001$, R^2 : .859), providing support for Hypothesis 1, the strong form. This finding indicates that a second-order factor accounting for the complementarity among management control mechanisms has a positive effect on firm performance. In Figure 4, only two of the five structural parameters, cultural social control mechanisms (standardized β coefficient: .399 $p < .001$) and behavioral control mechanisms (standardized β coefficient: .400 $p < .001$, collective R^2 from all additive effects: .805), from management control mechanisms to firm performance are significant (also see Table 6, Panel A). Financial and non-financial output control mechanisms and social visual control mechanisms do not contribute to performance in isolation. Thus, Hypothesis 2, the weak form, is not supported. Both the standardized β coefficient and R^2 from the complementary factor to firm performance are greater than the collective R^2 and the standardized β coefficients in the additive model. These results suggest that the complementary effects on firm performance among the complete set of Lean management control mechanisms outweigh their individual performance effects, providing further acceptance for Hypothesis 1⁵⁵.

⁵⁵ As suggested by Camacho-Minano *et al.* (2013), we controlled for size and unionization. Size was proxied for by the number of facility employees and facility sales, and respondents were asked to indicate whether their facility was fully unionized or not. We ran

Table 6: Panel A: Hypotheses tests (weak form)

Independent variable		Dependent variable	Standardized coefficient
VSC	-->	Firm performance	.094
CSC	-->	Firm performance	.399***
OUTNF	-->	Firm performance	.058
OUTF	-->	Firm performance	.082
BC	-->	Firm performance	.400***

R^2 Firm performance: .805

Panel B: Hypothesis test (strong form)

Independent variable		Dependent variable	Standardized coefficient
Complementarity	-->	Firm performance	.927***

R^2 Firm performance: .859.

***significant at the $p < .001$ level.

We have decided to report the fit indices in Figures 3 and 4, for which there are consensus in the structural equation modeling literature (Kline, 2011), although Tanriverdi and Venkatraman (2005) chose not to do so. All fit indices indicate acceptable fit.

tests with respect to both hypotheses where size variables were additively related to firm performance and chi-square difference tests where size variables moderated all structural relationships. We ran the same tests regarding unionization. We find that all statistical inferences remain similar across all tests

Figure 3: Hypothesis test 1 (strong form)

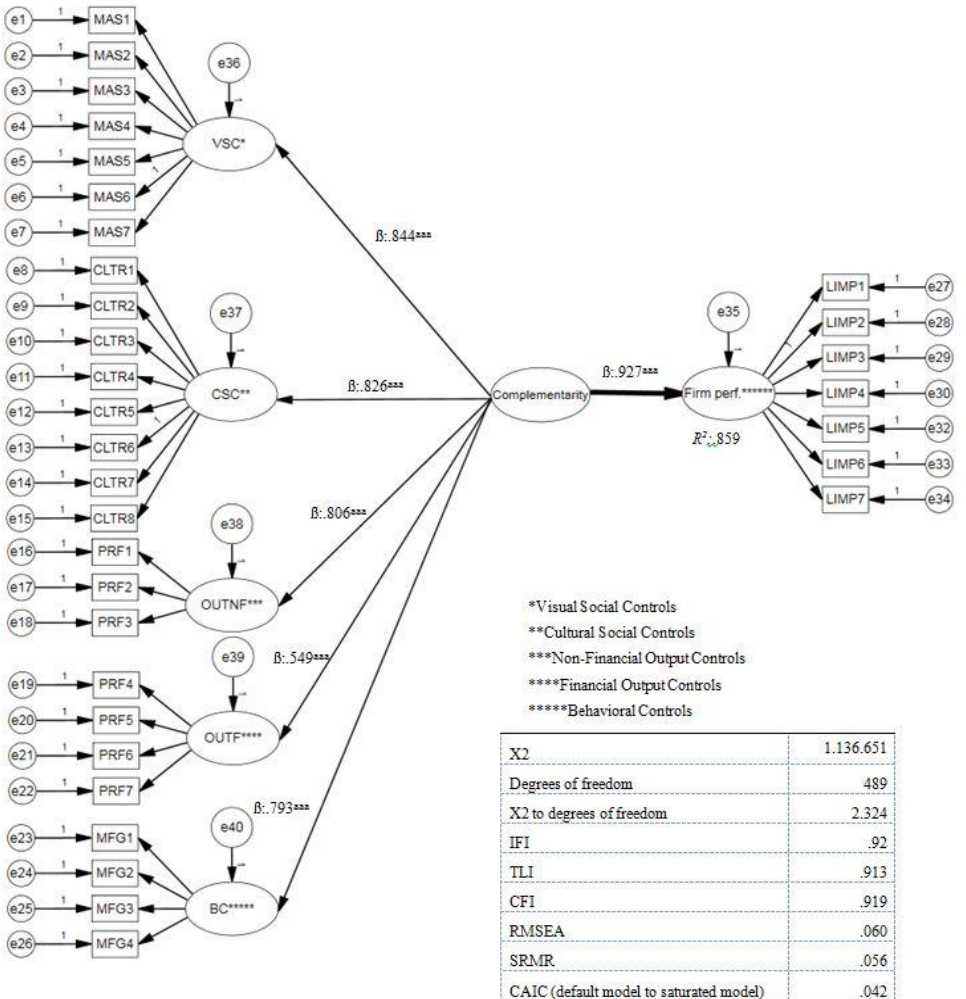

***Significant at $p < .001$

The bold arrow indicates a significant relationship from the exogenous variable to the endogenous variable.

Figure 4: Hypothesis test 2 (weak form)

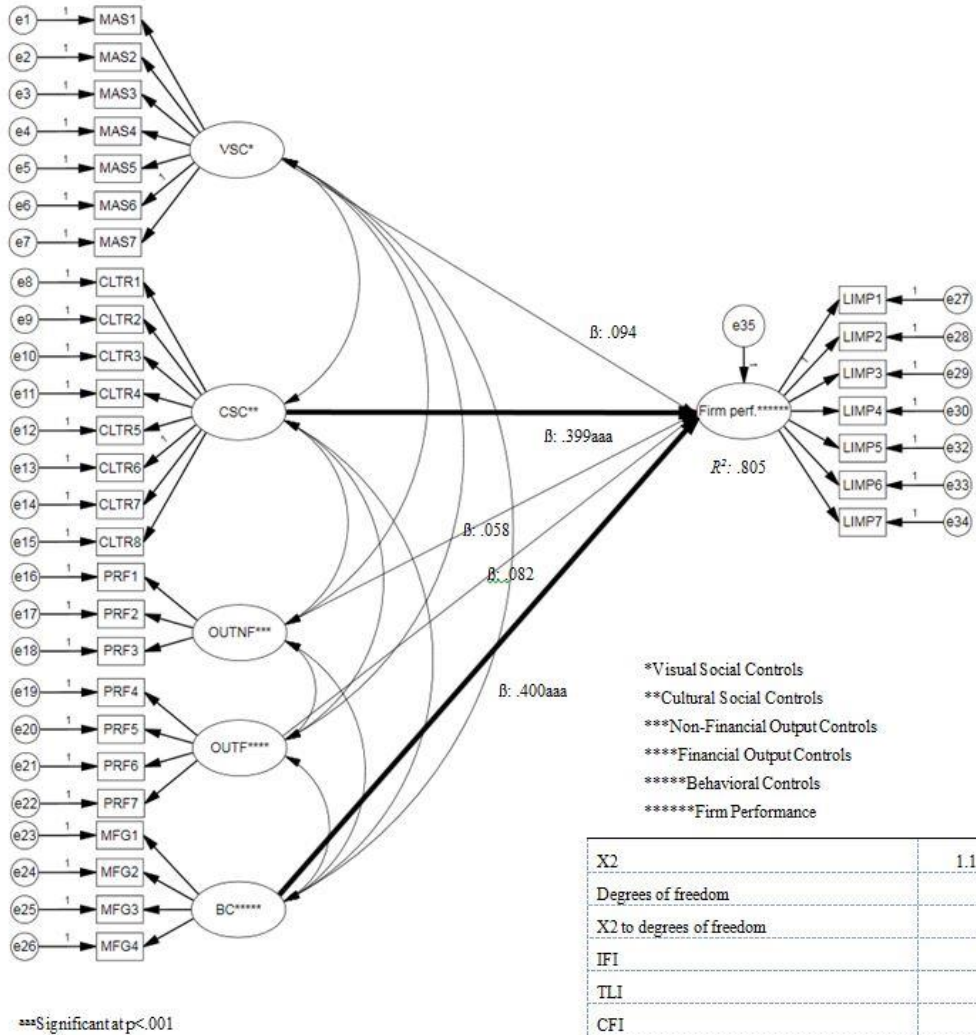

Bold arrows indicate significant relationships from exogenous variables to the endogenous variable.

- *Visual Social Controls
- **Cultural Social Controls
- ***Non-Financial Output Controls
- ****Financial Output Controls
- *****Behavioral Controls
- *****Firm Performance

X2	1.103.884
Degrees of freedom	480
X2 to degrees of freedom	2.300
IFI	.923
TLI	.915
CFI	.922
RMSEA	.060
SRMR	.054
CAIC (default model to saturated model)	.043

10.5 Discussion and Conclusion

This study focused on complementarities among management control mechanisms in Lean manufacturing companies. Little research has been carried out on this topic, which is rather paradoxical, as Lean manufacturing is recognized as an enterprise-wide system consisting of interdependent practices (Liker, 2004; Maskell *et al.*, 2012). Our aim with this research was to study Lean management control mechanisms and their complementary effects on firm performance. Earlier research provides limited evidence of complementarity among Lean management control mechanisms. Emiliani *et al.* (2003) and Kennedy and Widener (2008) were single firm studies and found that Lean management control mechanisms were interrelated, but did not provide evidence of complementary effects from Lean management control mechanisms to firm performance. Kristensen and Israelsen (2014) was a single firm study showing that greater balance among management control mechanisms led to greater firm performance, but their method made it difficult to capture the covariance and interactions among Lean management control mechanisms. Fullerton *et al.* (2013) was a cross-sectional study and found that management control mechanisms were interrelated. However, the study did not provide evidence of the complementary effects from Lean management control mechanisms to firm performance, and did not encompass the complete set of management control mechanisms.

Informed by the Lean manufacturing literature and complementary theory, we expected that Lean management control mechanisms were complementary. We utilized the holistic framework developed by Kennedy and Widener (2008), which characterizes Lean management control mechanisms as social, behavioral, and output control mechanisms. In order to confirm that management control mechanisms were complementary, we constructed two competing hypotheses. The

first hypothesis predicted that the complementarity of management control mechanism was positively related to firm performance. The second hypothesis predicted that the management control mechanisms were independently, additively related to firm performance. By constructing two competing hypotheses, we were able to compare the performance effects of individual system components with the performance effects of the complementarity among system components, and we were able to point out the conditionality of individual effects on the effects of other system components (Tanriverdi & Venkatraman, 2005).

We contribute to the literature on Lean management control mechanisms in two major ways. We are the first to show that the complementary effects among Lean management control mechanisms outweigh their additive effects on firm performance. Thus, firm performance will suffer as a result of implementations that do not consider the complementarity among management control mechanisms (Roberts, 2004). Furthermore, only social cultural control mechanisms and behavioral control mechanisms were independently related to firm performance. Second, this research adds cross-sectional empirical evidence that the full set of Lean management control mechanisms is complementary. We also add greater granularity to the understanding of Lean management control mechanisms because we distinguish financial output controls from non-financial controls as well as social visual controls from cultural visual controls, and we add a detailed analysis of their systematic interrelatedness. In other words, we provide evidence of five different management control mechanisms compared with the three found in Kennedy and Widener's (2008), and Kristensen and Israelsen's (2014) studies. Inspired by Ouchi (1979), we also extend the Kennedy and Widener (2008) framework by incorporating Lean thinking into social control mechanisms. The

greater granularity and greater level of detail are important steps forward in understanding Lean management control mechanisms.

To illustrate our findings, consider that non-financial output control mechanisms are not recognized as complementary with peer pressure (a social cultural control mechanism) in the system. That will lead to a reduction of the motivational effects otherwise promoted by non-financial output control mechanisms. Likewise, the effects of structuring the manufacturing facility with high visibility (a social visual control mechanism) are reduced if managers do not recognize the complementarity with training in Lean principles (a social cultural control mechanism), as employees will not be able to assist other manufacturing cells in preventing problems or improving work processes. Furthermore, if managers do not recognize that visualization of quality data (a social visual control mechanism) is complementary with standardization (a behavioral control mechanism), the effects of visualization of quality data are reduced, as it is difficult to leverage for continuous improvement, because employees have no baseline from which they can test potential improvements. The performance effects of financial and non-financial output control mechanisms and of social visual control mechanisms are thus not isolated additive effects; they affect performance through their complementarity with social cultural control mechanisms and behavioral control mechanisms.

In a Lean manufacturing milieu, social cultural control mechanisms and behavioral control mechanisms are then not only enhancers of firm performance but also enablers for the performance effects of financial and non-financial output control and social visual control mechanisms. In a similar vein, the effects of social cultural control mechanisms and behavioral control mechanisms on firm performance are greater when they are accompanied by non-financial output

control and social visual control mechanisms in a complementary system. This underlines that the greatest benefits from Lean management control mechanisms arise when they are implemented in a complete, systematic manner.

Methodologically, this study makes two contributions to the management control literature. First, we use a second-order factor technique to find evidence of complementarity among management control mechanisms. This technique is new to this body of literature and it overcomes the struggles of other techniques testing for complementarities. The second methodological advance of this study is that we show the specifics of management control mechanisms in a Lean manufacturing context and show how individual management control mechanisms are related (Malmi & Brown, 2008).

Our findings have important managerial implications. First, companies will not achieve the full performance potential of implementing Lean manufacturing if they decide to employ a system where some of the management control mechanisms are missing. In line with this reasoning, and if a company has already employed for example social control mechanisms, it should invest in implementing the remaining management control mechanisms rather than putting more effort into the existing one. Second, the implementation of all Lean management control mechanisms affects the entire company, and employees might have to unlearn old principles and practices before new ones can be put fruitfully into use. Thus, the implementation of the full set of management control mechanisms should be performed with a great emphasis on company-wide coordination, and companies would benefit from preparing employees thoroughly before embarking on the Lean manufacturing journey. Third, it is important for decision makers to understand that the performance effect of the implementation of one management control mechanism is dependent on the level of implementation of another management control

mechanism, and vice versa, and that the company will not obtain the full performance effects until the system of management control mechanisms is completely implemented. Therefore, although initial performance effects might be lower than expected, the company should not hesitate with respect to increasing the level of the implementation of Lean management control mechanisms. In fact, our research enables decision makers a greater ex ante understanding of how Lean management control mechanisms work together which can guide and assist them in overcoming some hesitations related to implementing the tightly coupled system of management control mechanisms. This ex ante guidance leaves less to understand for decision makers post hoc, and can enable the organizational change and complex coordination that the implementation of the full set of complementary Lean management control mechanisms requires (Robert 2004; Ennen and Richter, 2010). Fourth, the set of questionnaire items that we developed in this research can be applied by practitioners during Lean audits to ensure that they are on track and reaching Lean manufacturing objectives, and the set of items can be used as a benchmarking tool between business units. Fifth, our evidence suggests that decision makers should understand that financial output control mechanisms remain important in Lean manufacturing companies. In the literature, e.g. Johnson (1992), it is typically noted that such control mechanisms should be avoided and substituted with non-financial control mechanisms, but we have shown that non-financial and financial control mechanisms are complementary. Finally, Lean management control mechanisms might be relatively easy to replicate between companies. Furthermore, knowledge of Lean principles and practices is widespread. After all, these principles and practices have received abundant attention since the late eighties (Bhamu and Sangwan, 2014). Therefore, despite that initial costs might be high, companies should go far in order to understanding the *complementarity* among the complete set of management control mechanisms as it

may lead to a sustainable competitive advantage because it is difficult for competitors to replicate (Porter, 1996).

10.6 Future research and limitations

As with other studies, this study has its limitations. As our study is of a cross-sectional nature, it is difficult to claim causal inferences, and we cannot rule out that unobserved factors may be driving our evidence. Rather, our evidence must be considered as consistent with our theoretical arguments. Furthermore, our sample is not random, as it was drawn from a population of Lean companies. This reduces the generalizability of our evidence to other manufacturing regimes, but it also increases the likelihood of the population understanding the survey questions and consequently helps alleviate some of the concerns about data collection in survey research (Fullerton *et al.*, 2013). Last, surveying only one respondent in each firm represents a potential common method bias problem. However, we addressed this limitation and found that it was not a concern.

Our study suggests that examining the benefits or effects of financial and non-financial control mechanisms and social visual control mechanisms in isolation at Lean companies may lead to inconsistent results due to a failure to control for social cultural and behavioral control mechanisms. Future research on management control in Lean companies must then encompass a focus on the entire set of management control mechanisms. The simultaneous, systematic implementation of Lean management control mechanisms might overwhelm employees' absorptive capacity (Cohen and Levinthal, 1990). A possible future research endeavor is then to clarify if the effects of Lean management control mechanisms on firm performance are affected by the length of time companies have used Lean manufacturing. A second future research idea is to clarify whether our findings are applicable to more loosely coupled manufacturing regimes. In these manufacturing

regimes, the individual management control mechanism might work, as practices are less interdependent (Roberts, 2004). Testing for complementarities among management controls has recently been debated (see Grabner & Moers, 2013). We consider the second-order technique as an important addition to this debate, and we suggest that future management control research on complementarities should consider using the second-order technique.

10.7 Appendix 1

Table 1: Criterion Validity

Measure	Test variable	Explanation for correlation	Properties test variable	Correlation
OUTNF	Cost of quality	If a firm uses non-financial control mechanisms, it is likely to measure the cost of quality.	Single item	.583**
OUTNF	Productivity	If you use non-financial management control mechanisms, you are likely to measure productivity.	Single item	.515**
OUTNF	On-time deliveries	If a firm uses non-financial management control mechanisms, we expect it to measure on-time deliveries.	Single item	.431**
OUTNF	First-pass yields	We expect that if a firm uses non-financial control mechanisms, it is likely to measure first-pass yields.	Single item	.538**
OUTNF	Cycle time improvements	If a firm uses non-financial management control mechanisms, it is likely to measure cycle time improvements.	Single item	.573**

** correlation is significant at $p < .01$ (two-tailed)

Table 2: Survey Items

Social cultural controls

Please indicate below what most closely represents your facility's organizational culture.

1: Strongly Disagree, 2: Disagree, 3: Neutral, 4: Agree, 5: Strongly Agree

CLTR 1	Management style is more participative than autocratic
CLTR 2	Management is committed to quality-related training
CLTR 3	All employees are involved in problem solving
CLTR 4	Our entire facility is trained in lean principles
CLTR 5	Every area of our facility works on continuous improvement
CLTR 6	Management is focused on eliminating waste everywhere
CLTR 7	Lean thinking has permeated all of our operations
CLTR 8	Team members feel peer pressure to perform

Social visual controls

For the following items, please mark the most appropriate response related to your facility's management accounting system.

1: Strongly Disagree, 2: Disagree, 3: Neutral, 4: Agree, 5: Strongly Agree

MAS 1	Standard operating procedures are visible on the shop floor
MAS 2	Visual boards are used to share information
MAS 3	A training skills matrix is visible on the shop floor
MAS 4	Charts showing defect rates are posted on the shop floor
MAS 5	We have created a visual mode of organization
MAS 6	Information on productivity is updated frequently on the shop floor
MAS 7	Quality data is displayed at work stations

Behavioral controls

Please indicate below the extent to which your facility has implemented the following

1: Not at all, 2: Little, 3: Some, 4: Considerable, 5: Great deal

MFG 1	Use of standardization
MFG 2	A <i>Kanban</i> system
MFG 3	Use of one-piece flow
MFG 4	Use of line balancing and level schedules

Non-financial output controls

Please indicate below how important these performance measures are to operations at your facility.

1: Not at all, 2: Somewhat, 3: Important 4: Very Important 5: Critical

PRF1	Non-financial measures related to cell performance
PRF2	Non-financial measures related to value stream performance
PRF3	Non-financial measures related to facility performance

Financial output controls

Please indicate below how important these performance measures are to operations at your facility.

1: Not at all, 2: Somewhat, 3: Important 4: Very Important 5: Critical

PRF 4	Market share
PRF 5	Cash flow
PRF 6	Overall financial results
PRF 7	Customer satisfaction

Firm performance

Please indicate to what extent lean initiatives have affected the following

1: Not at all, 2: Little, 3: Some, 4: Considerable, 5: Great deal

LIMP 1	Inventory-related resources have been freed up
LIMP 2	Capacity is managed more effectively
LIMP 3	Cycle/production time is improved
LIMP 4	Quality is improved
LIMP 5	Overall communication is improved
LIMP 6	Costs are reduced
LIMP 7	Profitability is improved

10.8 Literature

- Adler, P. S. and Borys, B. (1996), "Two types of bureaucracy: Enabling or coercive", *Administrative Science Quarterly*, Vol. 41 No. 1, pp. 61-89.
- Ahrens, T. and Chapman, C. S. (2004), "Accounting for flexibility and efficiency: A field study of management control systems in a restaurant chain", *Contemporary Accounting Research*, Vol. 21 No. 2, pp. 271-301.
- Anthony, R. N. (1965), *Planning and Control Systems: A Framework for Analysis*, Harvard Business School, Massachusetts.
- Bagozzi, R. P. and Yi, Y. (1988), "On the evaluation of structural equation models", *Journal of the Academy of Marketing Science*, Vol. 16 No. 1, pp. 74-94.
- Banker, R., Potter, G. and Schroeder, R. (1993), "Reporting manufacturing performance measures to worker: An empirical study", *Journal of Management Accounting Research*, Vol. 5 No. 1, pp. 33-53.
- Belekoukias, I., Garza-Reyes, J. A. and Kumar, V. (2014), "The impact of lean methods and tools on the operational performance of manufacturing organizations", *International Journal of Production Research*, Vol. 52 No. 18, pp. 5346-5366.
- Bentler, P. M. (1990), "Comparative fit indexes in structural models", *Psychological Bulletin*, Vol. 107 No. 2, pp. 238-246.
- Bentler, P. M. (1992). "On the fit of models to covariances and methodology to the *Bulletin*". *Psychological Bulletin*, Vol. 112 No. 3, pp. 400-404.
- Bhamu, J. and Sangwan, K. S. (2014), "Lean manufacturing: literature review and

- research issues”, *International Journal of Operations and Production Management*, Vol. 34 No. 7, pp. 876-990.
- Bollen, K. A. (1989), *Structural equation with latent variables*, Wiley, New York.
- Bozdogan, H. (1987), “Model selection and Akaike's information criteria (AIC): The general theory and its analytical extensions”, *Psychometrika*, Vol. 52 No. 3, pp. 345-370.
- Browne, M. W. and Cudeck, R. (1993), *Alternative ways of assessing model fit*, In: Bollen, K. A and Long, J. S. (Eds.). *Testing Structural Equation Models*. Sage, California, pp. 136-162.
- Byrne, B. M. (2010), *Structural Equation Modeling with AMOS – Basic Concepts, Applications, and Programming*, 2nd edition, Routledge, Taylor & Francis Group. New York.
- Callen, J., L., Morel, M. and Fader, C. (2005), “Productivity measurement and the relationship plant performance and JIT intensity”, *Contemporary Accounting Research*, Vol. 22 No. 2, pp. 271-309.
- Camacho-Minano, Maria-del-Mar., Moyano-Fuentes, J. and Sacristán-Díaz, Macarena. (2013), “What can we learn from the evolution of research on lean management”, *International Journal of Production Research*, vol. 54 No. 4, pp. 1098-1116.
- Chavez, R., Yu, W., Jacobs, M., Fynes, B., Wiengarten, F. and Lecuna, A. (2015), “Internal lean practices and performance: The role of technological turbulence”, *International Journal of Production Economics*, Vol. 160 No. 1, pp. 157-171.
- Crocker, L. and Algina, J. (1986), *Introduction to Classical and Modern Test Theory*, Harcourt, Brace and Jovanovich, Texas.

- Cohen, W. M. and Levinthal, D. A. (1990), “Absorptive capacity: A new perspective on learning and innovation”, *Administrative Science Quarterly*, Vol. 35 No. 1, pp. 128–152.
- Cua, K. O., Mckone, K. E. and Schroeder, R. G. (2001), “Relationships between implementation of TQM, JIT and TPM and manufacturing performance”, *Journal of Operations Management*, Vol. 19 No. 6, pp. 675-694.
- Cunningham, J. E. and Fiume, O. J. (2003), *Real numbers: Management accounting in a lean organization*, Managing Time Press, North Carolina.
- Drazin, R. and Van de Ven, A., H. (1985), “Alternative Forms of Fit in Contingency Theory”, *Administrative Science Quarterly*, Vol. 30 No. 4, pp. 514-539.
- Emiliani, M. L., Stec, D. and Grasso, L. (2003), *Better thinking, better results*, The Center for Lean Business Management, LLC, Connecticut.
- Ennen, E. and Richter, A. (2010), “The whole is more than the sum of its parts – or is it? A review of the empirical literature on complementarities in organizations”, *Journal of Management*, Vol. 36 No. 1, pp. 207-233.
- Eustler, J. and Lang, B. (2015), “Rating scales in accounting research: The impact of scale points and labels”, *Behavioral Research in Accounting*, Vol. 27 No. 2, pp. 35-51.
- Ezzamel, M. and Willmott, H. (1998), "Accounting, remuneration and employee motivation in the new organization", *Accounting and Business Research*, Vol. 28 No. 2, pp. 97–110.

- Farris, J. A., Van Anken, E. M., Doolen, T. L. and Worley, J. (2009), "Critical success factors for human resource outcomes in Kaizen events: An empirical study", *International Journal of Production Economics*, Vol. 117 No. 1, pp. 42-65.
- Field, A. P. (2005), *Discovering statistics using SPSS* (2nd ed.). Sage, London.
- Fornell, C., and Larcker, D. F. (1981), "Evaluating structural equation models with unobservable variables and measurement error", *Journal of Marketing Research*, Vol. 18 No. 1, pp. 39–50.
- Fullerton, R. R. and Wempe, W. F. (2009), "Lean manufacturing, non-financial performance measures, and financial performance", *International Journal of Production & Operations Management*, Vol. 29 No. 3, pp. 214-240.
- Fullerton, R. R., Kennedy, F. and Widener, S. K. (2013), "Management accounting and control practices in a lean manufacturing environment", *Accounting, Organizations and Society*, Vol. 38 No. 1, pp. 50-71.
- Fullerton, R. R., Kennedy, F. and Widener, S. K. (2014), "Lean manufacturing and firm performance: The incremental contribution of lean management accounting practices", *Journal of Operations Management*, Vol. 32 No. 7-8, pp. 414-428.
- Furlan, A., Dal Pont, G. and Vinelli, A. (2010), "On the complementarity between internal and external just-in-time bundles to build and sustain high performance manufacturing", *International Journal of Production Economics*, Vol. 7 No. 2, pp. 489-495.
- Furlan, A., Vinelli, A. and Dal Pont, G. (2011), "Complementarity and lean manufacturing bundles: An empirical analysis", *International Journal of*

Operations & Production Management, Vol. 31 No. 8, pp. 835-850.

Grabner, I. and Moers, F. (2013), "Management control as a system or a package? Conceptual and empirical issues", *Accounting, Organizations & Society*, Vol. 38 No. 6-7, pp. 407-419.

Gerdin, J. and Greve, J. (2004), "Forms of contingency fit in management accounting research – A critical review", *Accounting, Organizations & Society*, Vol. 29 No. 3-4, pp. 303-326.

Hair, J., Black, W., Babin, B., and Anderson, R. (2014). *Multivariate data analysis* (7th ed.). Pearson Education Limited, England.

Henri, J-F. (2006), "Organizational culture and performance measurement systems", *Accounting, Organizations & Society*, Vol. 31 No. 1, pp. 77-103.

Hofer, C., Eroglu, C. and Hofer, A. R. (2012). "The effect of lean production on financial performance: The mediating role of inventory leanness", *International Journal of Production Economics*, Vol. 138 No. 2, pp. 242-253.

Hult, T., Boyer, K. K. and Ketchen D. J. (2007), "Quality, operational logistics strategy, and repurchase intentions: A profile deviation analysis", *Journal of Business Logistics*, Vol. 28 No. 2, pp. 105–132.

Ichniowski, C., Shaw, K. and Prennushi, G. (1997), "The effects of human resource management practices on productivity: a study of steel finishing lines", *American Economic Review*, Vol. 87 No. 3, pp. 291-313.

Jayaram, J., Das, A. and Nicolae, M. (2010), "Looking beyond the obvious: Unraveling the Toyota production system", *International Journal of Production Economics*, Vol. 128 No. 1, pp. 280-291.

- Johnson, H. T. (1992), *Relevance regained: From top-down control to bottom-up empowerment*. The Free Press, New York.
- Kennedy, F. A. and Widener, S. K. (2008), “A control framework: Insights from evidence on Lean accounting”, *Management Accounting Research*, Vol. 19 No. 4, pp. 301-323.
- Kenny, D. A. (2012). *Multiple latent variable models: confirmatory factor analysis*. <http://davidakenny.net/cm/mfactor.htm> visited online: 09-16-2016.
- Khanchanapong, T., Prajogo, D., Sohal, A., S., Cooper, B., K., Yeung, A., C., L. and Cheng, T., C., E. (2014), “The unique and complementary effects of manufacturing technologies on manufacturing and operational performance”, *International Journal of Production Economics*, Vol. 153 No. 3, pp. 191-203.
- Kihn, L. A. (2005), “Comparing performance measurement approaches in accounting research”, *Finnish Journal of Business Economics*, No 2, pp. 143-184.
- Kline, R. B. (2005), *Principles and practices of structural equation modeling*, 2nd edition, The Guildford Press, New York.
- Kline, R. B. (2011), *Principles and practice of structural equation modeling*, 3rd edition. The Guilford Press, New York:
- Krafcik, J. F. (1988), “Triumph of the Lean production system”, *Sloan Management Review*, Vol. 30 No. 1, pp. 41-52.
- Kristensen, T. B. and Israelsen, P. (2014), “Performance effects of multiple control forms in a Lean organization: A quantitative case study in a systems fit approach”, *Management Accounting Research*, Vol. 25 No. 1, pp. 45-62.

- Lind, J. (2001), "Control in world class manufacturing—a longitudinal case study", *Management Accounting Research*, Vol. 12 No. 1, pp. 41–74.
- Liker, J. (2004), *The Toyota Way*. McGraw-Hill. New York.
- Maiga, A., S. and Jacobs, F., A. (2008), "Assessing JIT performance: An econometric approach", *Journal of Management Accounting Research*, Vol. 20 No. 2, pp. 47-59.
- Malmi, T. and Brown, D, A. (2008), "Management control systems as a package – Opportunities, challenges and research directions", *Management Accounting Research*, Vol. 19 No. 4, pp. 287-300.
- Marsh, H. W. and Hocevar, D. (1985), "Application of confirmatory factor analysis to the study of self-concept: First- and higher order factor models and their invariance across groups", *Psychological Bulletin*, Vol. 97 No. 3, pp. 562-582.
- Maskell, B., Baggaley, B. and Grasso, L. (2012), *Practical Lean Accounting – A Proven System for Measuring and Managing the Lean Enterprise*, CRC Press, Florida.
- Milgrom, P. and Roberts, J. (1995), "Complementarities and fit, strategy, structure and organizational change in manufacturing", *Journal of Accounting and Economics*, Vol. 19 No. 2-3, pp. 179-208.
- Miltenberg, J. (2001), "One-piece flow manufacturing on U-shaped production lines: A tutorial", *IIE Transactions*, Vol. 33 No. 4, pp. 303-321.
- Netland, T. H., Schloetzer, J. D. and Ferdows, F. (2015), "Implementing corporate lean programs: The effect of management control practices", *Journal of Operations Management*, Vol. 36 No. 3, pp. 90-102.

- Ouchi, W. G. (1978), "The transmission of control through organizational hierarchy", *Academy of Management Journal*, Vol. 21 No. 2, pp. 173-192.
- Ouchi, W. G. (1979), "A conceptual framework for the design of organizational control mechanisms", *Management Science*, Vol. 25 No. 9, pp. 833-848.
- Podsakoff, P.M. and Organ, D.W. (1986), "Self-reports in organizational research: problems and prospects", *Journal of Management*, Vol. 12 No.4, pp. 531-544.
- Porter, M. E. (1996), "What is strategy?" *Harvard Business Review*, Vol. 68 No. 3, pp. 79-91.
- Rindskopf, D. and Rose, T. (1988), "Some theory and applications of confirmatory second-order factor analysis", *Multivariate Behavioral Research*, Vol. 23 No. 1, pp. 51-67.
- Roberts, J. (2004), *The modern firm – organizational design for performance and growth*. Oxford University Press, New York.
- Rondeau, P.J., Vonderembse, M.A. and Ragu-Nathan, T.S. (2000), "Exploring work system practices for time-based manufacturers: their impact on competitive capabilities", *Journal of Operations Management*, Vol. 18 No. 5, pp. 509–529.
- Schermelleh-Engel, K., Moosbrugger, H. and Muller, H. (2003), "Evaluating the fit of structural equation models: tests of significance and descriptive goodness-of-fit measures", *Methods of Psychological Research Online*, Vol. 8 No. 2, pp. 23-74.
- Secchi, R. and Camuffo, A. (2016), "Rolling out lean production systems: a knowledge-based perspective", *International Journal of Operations and Production Management*, Vol. 36 No. 1, pp. 61-85.
- Shah, R. and Ward, P., T. (2003), "Lean manufacturing: Context, practice bundles, and performance", *Journal of Operations Management*, Vol. 12 No. 2, pp. 129-

- Shah, R. and, Ward, P., T. (2007), "Defining and developing measures of lean production", *Journal of Operations Management*, Vol. 25 No. 4, pp. 785-805.
- Snell, S. A. (1992), "Control theory in strategic human resource management: The mediating effect of administrative information", *Academy of Management Journal*, Vol. 35 No. 2, pp. 292-327.
- Tanriverdi, H. and Venkatraman, N. (2005), "Knowledge relatedness and the performance of multibusiness firms", *Strategic Management Journal*, Vol. 26 No. 2, pp. 97-119.
- Tucker, L. R. and Lewis, C. (1973). "A reliability coefficient for maximum likelihood factor analysis", *Psychometrika*, Vol. 38 No. 1, pp. 1-10.
- Williams, L. J., Gavin, M. B. and Hartman, N. S. (2004), "*Structural Equation modeling methods in strategy research: Applications and issues*", In *Research Methodology in Strategy and Management*, 1. Ketchen, D. J. and Berg, D. D (Eds). Elsevier/JAI press, Connecticut, pp. 33-65.
- Whittington, R., Pettigrew, A., Peck, S., Fenton, E. and Conyon, M. (1999), "Change and complementarities in the new competitive landscape: A European panel study, 1992-1996", *Organization Science*, Vol. 10 No. 5, pp. 583-600.
- Woolson, D. and Husar, M. A. (1998), "Transforming a plant to lean in a large, traditional company: Delphi Saginaw Steering Systems GM", In *Becoming Lean: Inside Stories of U.S. Manufacturers*, edited by J. K. Liker, 120-159. Productivity Press, Oregon.
- Worthington, R. L. and Whittaker, T. A. (2006), "Scale development research, a content analysis and recommendations for best practices", *The Counseling Psychologist*, Vol. 34 No. 6, pp. 806-838.

Wood, R., Herscher, M. and Emiliani, M. L. (2015), *Shingijutsu-Kaizen – The Art of Discovery and Learning*, The Center for Lean Business Management, LLC, Connecticut.

Åhlström, P. and Karlsson, C. (1996), “Change towards Lean production: The role of the management accounting system”, *International Journal of Operations & Production Management*, Vol. 16 No. 11, pp. 42-56.

11. Paper 5: The relations between lean manufacturing, lean thinking, management accounting and firm performance – it is about time

Thomas Borup Kristensen^a, Henrik Nielsen^a, and Lawrence P. Grasso^b

^a*Department of Business and Management, Aalborg University*

^b*The Accounting Department, Central State Connecticut University*

Keywords: Lean manufacturing; management accounting; lean thinking; time compression diseconomies

Abstract

This study addresses a holistic perspective on lean, where associations between lean manufacturing, management accounting practices, lean thinking, and performance are studied. It also investigates whether the operational performance effects from lean manufacturing, lean thinking and lean visual controls are moderated by the length of time companies' have used lean manufacturing. By examining a structural equation model with survey data from 368 different manufacturing facilities, we find positive associations between lean manufacturing and all management accounting practices. We also find that lean manufacturing, value stream costing, and lean visual controls are positively related to lean thinking. Lean thinking is positively related to operational performance and lean

manufacturing, and value stream costing and lean visual controls are indirectly related to operational performance through lean thinking. Additionally, we find that the performance effects of lean manufacturing and lean visual controls are moderated by the length of time companies have used lean manufacturing.

11.1 Introduction

The term “lean manufacturing” was coined by Krafcik (1988) and colleagues during their study of the Toyota Production System as part of the MIT international vehicle program. Today, lean manufacturing is recognized as an integrated management system (Emiliani et al. 2003; Kennedy and Widener 2008; Shah and Ward 2007) and has garnered widespread adoption as an enabler for companies to succeed in an increasingly competitive environment.

A key to the success of a lean initiative is that management accounting practices are aligned with lean objectives (Fullerton et al. 2014; Åhlström and Karlsson 1996). In some parts of the accounting literature, the consensus is that companies should shift away from using standard costing because of the inherent dysfunctional behavioral consequences for the lean strategy (e.g., Huntzinger 2007; Huntzinger and Kennedy 2005; Kaplan and Cooper 1998). Yet the literature is not completely explicit regarding whether it is standard absorption costing and/or standard direct costing that has dysfunctional consequences for lean. In this study we focus explicitly on measurements of direct labor and materials efficiency. Some

of the lean accounting literature also claims that these are problematic in lean manufacturing (Maskell and Kennedy 2007; Maskell et al. 2012). However, the evidence is not consistent. For example, Kennedy and Widener (2008) found that their lean manufacturing case company substituted labor variances with actual costs and relied heavily on non-financial controls. Likewise, Fullerton et al. (2013; 2014) found that lean manufacturing companies, in addition to relying heavily on non-financial controls, used value stream costing. Other empirical evidence suggests that lean manufacturing companies continue to use direct labor and materials efficiency variances. For example, Banker et al. (1993) found that just-in-time (JIT) companies continued to use labor efficiency measures together with non-financial performance measures. In another study, Lind (2001) found that the case company continued to use efficiency variance analyses in concert with non-financial performance measures.

Another key for a successful lean manufacturing implementation is a change in mindsets (Emiliani et al. 2003; Womack and Jones 2003) in which lean thinking permeates the thinking of both employees and management. With lean thinking, management and employees share a constant focus on continuous improvement and problem solving; that they think, act, and behave with a passion for lean; and that they are trained according to lean principles. Lean thinking is important in lean manufacturing companies, as employees are given the autonomy to solve problems

and identify areas of improvement in order to achieve lean objectives. The first purpose of this study is to address the relationships between lean manufacturing, management accounting practices, lean thinking, and firm performance. In addition to measurements of labor and material efficiency (i.e., labor and materials efficiency variances), we use two components representing management accounting practices: value stream costing and lean visual controls. We hypothesize that lean manufacturing is positively related to these practices and that the practices are interdependent. We also hypothesize that lean manufacturing, value stream costing, and lean visual controls are positively related to lean thinking, and that lean manufacturing, lean visual controls, and lean thinking are positively related to operational performance.

The second purpose of this paper is to examine whether the relationships between lean manufacturing, lean visual controls, lean thinking, and operational performance are affected by the length of time companies have used lean manufacturing. As the implementation of lean manufacturing includes a complete reorganization of the production areas, investments in visual controls, and changes in employees' and management's mindsets, we expect that time with lean manufacturing affects our hypothesized relationships. For example, the hypothesized improvements in operational performance caused by lean manufacturing might materialize to a greater extent when employees and

management have experimented with different work solutions, learned how to work with lean manufacturing, and unlearned some of the skills and behaviors necessary under previous manufacturing regimes that might be detrimental to the lean manufacturing implementation. We explain these thoughts with the concept of time compression diseconomies (Dierickx and Cool 1989). Anecdotally, Vermeulen (2009) described how time affected his capability to play the cello. Intensifying his input by only practicing one day a week, he was not able to play a piece as well the seventh day compared to when he spread his input equally among six days. Using this anecdote in a lean manufacturing context would imply that companies will benefit more from lean manufacturing, lean thinking, and lean visual controls as a function of the length of time they have used lean manufacturing. We also examine whether the relationship between lean manufacturing and management accounting practices is moderated as a function of the experience that companies have with lean manufacturing.

Utilizing a cross-sectional sample of 368 lean manufacturing facilities, we use a structural equation model to examine our hypotheses. Not surprisingly, and supporting prior studies (Fullerton et al. 2013; 2014), we find that lean manufacturing is positively related to value stream costing and lean visual controls. We also find that lean manufacturing is positively related to measurements of direct labor and materials efficiency variances. In fact, we find that the relationship

between lean manufacturing and labor and materials efficiency variances is significantly greater at facilities with longer experience with lean manufacturing. This finding opposes the claims that standard costing (and all included budget variances) per se is detrimental to lean manufacturing (e.g., Huntzinger 2007; Johnson 1992; Kaplan and Cooper 1998; Maskell et al. 2012). We further find that the management accounting practices are interdependent and that lean visual controls and value stream costing are positively related to lean thinking. This supports the holistic perspective found in Fullerton et al. (2013). We also find that lean manufacturing and lean visual controls are positively related to operational performance, and the effect is intensified through lean thinking. Thus, lean thinking is a catalyst for lean manufacturing companies in achieving improved operational performance. In addition, we find that the relationships between lean manufacturing and operational performance and between lean visual controls and operational performance are significantly greater as a function of the length of time companies have used lean manufacturing. Thus, firms get greater benefit from lean manufacturing and lean visual controls as the employees and managers grow more experienced with lean manufacturing even if the extent of lean manufacturing and lean visual controls has not significantly increased

Our findings contribute to the literature in three key ways. We expand the understanding of how management accounting practices can assist lean

manufacturing companies. Thus, we respond to Åhlström and Karlssons' (1996) call for research on how management accounting practices integrate with operations and to Fullerton et al.'s (2013) call for research on ways these practices provide more useful information to decision makers in world-class firms. To the best of our knowledge, we provide the first survey-based evidence that more traditional measures of labor and material efficiency can supplement contemporary practices, value stream costing (VSC), and visual control to enhance performance, as opposed to substituting each other. Second, we show that companies can benefit more from lean manufacturing by getting every employee involved in lean and by ensuring that lean thinking has permeated the minds of all organizational members. Third, we show that lean manufacturing firms benefit more from lean visual controls and lean manufacturing as a function of the length of time firms have used lean manufacturing.

The remainder of this article is structured as follows: in section 2, we describe the literature and develop our hypotheses. In section 3, we present our method and sample, and in section 4, the results are presented and discussed. We summarize and conclude our paper in section 5, and present limitations and future research agendas in section 6.

11.2 Literature review and hypotheses development

The sections below include development of our hypotheses. In section 2.1, we develop hypotheses predicting relationships between lean manufacturing, management accounting practices, and lean thinking. In section 2.2, we develop hypotheses predicting relationships between lean manufacturing, lean visual controls, lean thinking, and operational and financial performance, while in section 2.3, we develop hypotheses predicting that the length of time companies' have used lean manufacturing moderates the inferred relationships from lean manufacturing, lean thinking, and lean visual controls to operational performance as well as from lean manufacturing to management accounting practices.

11.2.1 Hypotheses 1a–1g

Lean manufacturing relies on visual controls (Cunningham and Fiume 2003; Fullerton et al. 2013; Kennedy and Widener 2008; Zayko and Hancock 1998). Visual controls are used in lean companies to inform employees how work should be done and to visualize if current activities deviate from the expected standard (Emiliani et al. 2003; Liker 2004). Likewise, visual controls provide easy-to-understand performance measurements that should direct employees' attention to potential improvements and ensure that production objectives are aligned with the lean strategy (Liker 2004). However, visual controls go beyond informing employees about standards, improvement potentials, and deviations. Visual

controls are also related to structuring the facility with high visibility—meaning that employees should be able to help one another between work processes. This can be referred to as both internal and global transparency (Adler and Borys 1996), which reduces the risk of sub-optimization and enhances employees' understanding of the entire production process. Furthermore, as lean companies have reduced buffer-inventories, they need real-time surveillance of their production facilities, as break-downs and quality-related issues have severe effects on production flow and delivery of products to customers (Callen et al. 2005). Fullerton et al. (2013; 2014) found that lean manufacturing was positively associated with visual controls. Thus, we hypothesize the following:

H1a: Lean manufacturing is positively associated with lean visual controls.

Standard costing has been criticized in relation to its usability in lean manufacturing companies (e.g., Bergström 1995; Grasso 2005). Often the critique relates to the use of budget variance analyses. A central concern is that variance analyses produced by standard costing encourage large batch production and inventory building (Maskell et al. 2012); by increasing the number of outputs, standard hours will be credited and, *ceteris paribus*, the cost center in question will appear to be more efficient. Likewise, waste may be hidden in standards

(Kristensen and Israelsen 2013), making standard costing ill-equipped as an analytical tool for continuous improvement. Standard costs do not show root causes of problems (Huntzinger 2007), which are essential in lean manufacturing companies (Liker 2004); they are reported too late due to accounting period delays, which cause important improvements to be postponed or missed (Grasso 2005); and they are difficult for non-accountants to understand (Maskell et al. 2012). Another possible problem with standard costing measures in lean manufacturing companies is that they are embedded in traditional management control and thus impede the unlearning of the traditional practices and thinking necessary for lean to prosper. This can cause lean goal incongruent behavior, as employees might follow standards blindly instead of chasing continuous improvements. Fullerton et al. (2013; 2014) found in their cross-sectional study that while lean manufacturing companies used VSC, they did not capture whether lean manufacturing causes the abandonment of standard costing.

The literature is clear on the lean goal incongruent effects stemming from standard costing. However, the researchers who produced this literature are not very clear regarding whether they are referring to standard absorption costing variances and/or standard direct costing variances as being lean goal incongruent. The distinction between these is important, as they are, of course, very different. Standard direct costing variances calculates labor efficiency, materials use

efficiency, purchase price unit variances for direct labor and materials, and budget variances for variable overhead adjusted for volume. Standard absorption costing variances, in turn, calculates efficiency of indirect fixed costs based on standard cost overhead rates (Drury 1992). In this study, we focus on measurements of direct labor and materials efficiency (i.e., direct labor and materials efficiency variances), as absorption variances of indirect costs is not found to be beneficial anywhere in the literature. Measurements of direct labor and materials efficiency are also accused of motivating lean goal incongruent behavior in parts of the lean accounting literature. Researchers have claimed that measurements of direct labor and materials efficiency motivate employees to produce large batches, increase inventories, lengthen cycle time, and ruin flow (Maskell and Kennedy 2007; Maskell et al. 2012).

However, Drury (1992) argues that, by themselves, measurements of direct labor and materials efficiency do not per se lead to excessive inventories; rather, dysfunctional consequences arise because of the way managers use variance analyses. He also notes that measurements of direct labor and materials efficiency will continue to be important in lean manufacturing companies. Jönson and Grönlund (1988) describe that a company with a flow-based layout identifies an unfavorable materials variance in a standard costing system. The production foremen and workers gathered and analyzed what the reason for this unfavorable

materials variance might be. They concluded that a joint material used for two parts was too hard for the tool that was used to produce the parts. In correspondence with a supplier, they decided to get a harder and more expensive tool, which led to less material use. Thus, a materials variance reduced waste materials and was used to identify operational improvements.

Grasso et al. (2015) found that direct labor efficiency measurements were used in all lean case companies and reported that these measures are not especially problematic in lean manufacturing companies. Guilding et al. (1998) surveyed whether UK- and New Zealand-based companies abandon the use of standard costing and variance analysis. An important result of their study is that most respondents indicate “no change” when asked if JIT/advanced manufacturing technology will reduce the importance of variance analysis. Additionally, more respondents see variance analysis as being more important rather than less important in such an environment.

Sulaiman et al. (2005) surveyed local Malaysian firms and affiliates of Japanese companies in Malaysia on their use of several variance techniques. They found that 60% of the Japanese affiliates rated measures of material efficiency variance as above average or vitally important. Furthermore, 80% of them rated measures of labor variance as above average or vitally important. At the local Malaysian

companies, even more respondents rate these measures to be above average or vitally important. In Linds' (2001) case study of a world-class manufacturer, it was predicted that efficiency variance analyses at the individual process level would be abandoned and replaced by trend analysis because when employees were controlled against an agreed budget, they might stop improving performance once the budget was met. However, Lind (2001) found that the company continued to use efficiency variance analyses, albeit only at workgroup levels and in concert with non-financial measures. Likewise, Banker et al. (1993) found that plants employing JIT emphasized non-financial performance measures more compared to companies that did not employ JIT; however, they did not find any significant difference in the plants' reliance on direct labor variance reports.

In Jonsön and Grönlund's (1998) case company, the materials variance analysis was used as a management by exception tool. However, measures of direct labor and materials efficiency can also be applied if a lean manufacturing company seeks to optimize its direct cost base. For example, Monden and Lee (1993) describes Kaizen Costing, as a method that uses the actual direct labor and direct materials cost performance at the end of the previous year and compares it with the current cost performance which, in turn, is compared with a cost reduction target. Variances can then be computed between actual direct labor and material costs performance and the reduction target to induce continuous improvement, and

actual direct labor and material costs can be compared with the cost performance at the end of the previous year to highlight improvements. Further, the reduction target is continuously challenged. In this way, lean manufacturing companies can ensure continuous improvement of direct labor and material costs.

Based on these previous studies, we argue that measurements of direct labor and materials efficiency are indeed usable in lean manufacturing companies. They can be used as instruments for continuous improvement by showing variances between actual costs and cost reduction objectives. We also argue that managers might be hesitant to replace measurements of labor and materials efficiency that worked during previous production regimes and that they instead attempt to learn how to use them congruently with lean manufacturing (Åhlström and Karlsson 1996). These variance analyses can be beneficial as a supplement to other performance measures in lean manufacturing companies. Further, lean manufacturing may enable greater use of measurements of direct labor and materials efficiency, as it involves a heavy reliance on standardized work. Standardized work includes standard operating procedures, which are assigned for a length of time to carry out the work processes. This information and bills of materials can be used as standards for labor and materials usage. In sum, measurements of labor and materials efficiency can be useful to lean manufacturing companies and may not be

replaced by lean-related financial performance measures or completely substituted with solely non-financial measures. Thus, we hypothesize the following:

H1b: Lean manufacturing is positively associated with measurements of direct labor and materials efficiency.

Lean manufacturing reduces companies' need for standard full costing, as the production facilities are structured in value streams with no or as few shared resources as possible (Maskell et al. 2012). When companies structure the facility in value streams, the necessity for allocating capacity costs is reduced and a need for a management accounting system specifically designed for value streams arises (Brosnahan 2008). Datar et al. (1990) found that their case company's use of an accounting system with pooled resources and volume-based allocation drivers, i.e., standard full costing, blurred cost reductions stemming from improvements of work processes. Relatedly, Maskell et al. (2012) and Kristensen and Israelsen (2013) reported that standard full-cost driver rates can conceal and reduce employees' attention to the causes of waste. Kennedy and Widener (2008) found that their case company simplified the management accounting system after implementing lean, while Fullerton et al. (2013; 2014) found that lean manufacturing companies used VSC. VSC encompasses a separate income statement for each value stream and information on productive, non-productive,

and available capacity. This information is reported for prior periods, showing the performance trends leading to the current state, and for planned or desired future states to motivate continuous improvement and guide improvement efforts. VSC is well suited for lean companies, as it reveals the financial performance of a value stream, and covers the entire order to delivery process, and gives a clear picture of a value stream's profit and contribution to the organization's financial results (Maskell et al. 2012). Furthermore, VSC exposes bottleneck and capacity issues, and motivates continuous improvement in a simple, readily available, and efficient manner (Maskell and Kennedy 2007). Thus, VSC is a useful management accounting system in lean manufacturing companies because it tracks the total costs and the total profit of the value stream. We thus hypothesize the following:

H1c: Lean manufacturing is positively associated with VSC.

For lean manufacturing to prosper, a change of mindset among employees and management is needed (Fullerton et al. 2014). Continuous improvement resides at the core of lean manufacturing (Emiliani et al. 2003) and it is paramount that both employees and managers identify potentials for improvement, generate ideas, and engage in problem solving if the company is to be successful with lean manufacturing. Likewise, employees and managers need to ask themselves the following question: What is the essence of continuous improvement and how can

we increase our ability to continually improve? For this reflection to happen, managers and employees need to be trained in continuous improvement (Liker 2004), for example, by continuously going to the *genba*⁵⁶ and figuring out solutions or improvements (Ohno and Mito 1988). It is also important that employees and managers think, act, and behave with a passion for continuous improvement and are empowered to do so (Wood et al. 2015). This sort of lean thinking must be internalized and thus permeate the minds of all members in the facility if they are to solve problems and identify potentials for improvement. Extant literature finds that lean manufacturing involves several human resource practices, yet research on this broad concept of human resource practices is scarce. Fullerton and McWatters (2002), Fullerton et al. (2013), Kennedy and Widener (2008), and Lind (2001) found evidence of increased empowerment in lean manufacturing companies. Snell and Dean (1992) found that employees in operations in advanced manufacturing firms received comprehensive training. Shah and Ward (2003) found that lean manufacturing included cross-functional employees' engagement in problem solving. Kennedy and Widener (2008) found that their case company increased cross-training of employees, and it used a company-wide intranet to promote training in lean principles and skills. In their lean-implementing case company,

⁵⁶ “Genba” is a Japanese term for the place where the work or activity is performed. In lean, employees and managers are encouraged to observe practice and the problems occurring in practice for themselves rather than relying on second-hand reports.

Woolson and Husar (1998) found that it was of high importance that employees received training in team skills, the firm's new lean strategy, and continuous improvement. We conceptualize lean thinking as a state where all employees and managers are engaged in lean manufacturing, where they are trained according to and believe in lean principles, and where employees are empowered to perform problem solving. These elements are important if employees are to act in a lean manufacturing congruent manner (Hines et al. 2004). These elements are important if employees are to act in a lean manufacturing congruent manner. Thus, we hypothesize the following:

H1d: Lean manufacturing is positively associated with lean thinking.

Lean visual controls induce certain behavior and thinking among employees and management. For example, the case company described by Kennedy and Widener (2008) used "can do/needs help" flip charts in their production cells to highlight and prioritize problems and improvement opportunities identified and to track the progress being made toward implementing solutions. The "owner" of the idea or problem was displayed on the chart, and the owner indicated whether he/she needed assistance in solving problems or developing an idea (Kennedy and Widener 2008). This encouraged the "owner," i.e., shop-floor employees and facility managers, to engage in solving problems or testing/developing ideas and

challenged their current beliefs and behavior. Likewise, Liker (2004) argues that getting all employees involved in continuous improvement requires the constant use of visual performance measurements. Emiliani et al. (2003) found that recurring problems were highlighted on visual boards, which initiated a *kaizen*⁵⁷ for improving current processes. Empirical evidence of lean thinking is limited. However, following the arguments above, we contend that lean visual controls with information on objectives, ideas, problems, and flow induce lean thinking. With the information made visible to all, employees and managers are continually challenged to question current standards, their beliefs, and their behavior in order to achieve those objectives, develop ideas, and solve problems. Thus, we hypothesize the following:

H1e: Lean visual controls are positively associated with lean thinking.

VSC encompasses information on prior, present, and future financial performance objectives within the value stream (Maskell et al. 2012). For the value stream to reach the future performance objective, employees and managers must identify potential improvements and challenge their beliefs and behavior. In their lean case company, Åhlström and Karlsson (1996) found that a lean coherent management accounting system contributed to and drove lean. First and foremost, this related to

⁵⁷ "Kaizen" is a Japanese term for continuous improvement.

the cognitive influence that the management accounting system had on the employees. Employees recognized that the lean congruent management accounting system helped them develop lean in their facility. Solomon and Fullerton (2007) also argue that VSC improves the decision-making process and communication in lean manufacturing companies. As such, we hypothesize the following:

H1f: Value stream costing is positively associated with lean thinking.

Drury (1992) argues that measurements of labor and materials efficiency should be reported in physical terms on the shop floor (e.g., on visual boards) because in a lean environment these measurements are important for monitoring operations and for encouraging employees and managers to reach their objectives. When the measurements are visualized, managers and employees will be assured that lean is causing improvements in their company, which, in turn, fosters and preserves motivation. The visualization of measurements of labor and materials efficiency will also direct employees' and managers' attention to problems that need to be solved. For lean companies to fully capitalize on and act according to the information gained from VSC, the information must be visualized (Maskell et al. 2012). Because of the need for visualization in lean manufacturing, we expect that measurements of labor and materials efficiency are dependent on lean visual controls. There is little point in using VSC if the information is not shared with the

employees for whom it is intended. Thus, for VSC to work, it is dependent on lean visual controls for information sharing and motivating actions and behavior.

To comprehensively assist employees and management in the lean implementation, the non-financial information shared through visual controls needs to be combined with financial information. Henri (2006) contends that comprehensive performance measurement systems, which are both financial and non-financial, are intended to capture all important areas of the firm. Furthermore, Henri (2006) found that an attention-focusing use of performance measurement systems, which he describes as using the performance measurement system with an aim to stimulate communication and send signals related to strategic issues and to foster learning throughout the organization, was positively associated with diversity of measurement (meaning both financial and non-financial). In a lean manufacturing context, an attention-focusing use of performance measurement systems can drive behavior and actions that are congruent with lean. Ittner et al. (2003) argue that measurement diversity is an important aspect of comprehensive performance measurement systems. Measurement diversity is “supplementing financial measures with a diverse set of non-financial measures capturing the key strategic performance dimensions” (717). In a lean manufacturing context, this means that daily non-financial measurement needs to be combined with financial value stream cost measurements. Furthermore, measurements of direct labor and materials

efficiency can be used to translate the non-financial measures to financial measures in order to assure employees at higher hierarchical levels that lean manufacturing is progressing at the facilities (Tillema and van der Steen 2015). Senior management might be more willing to accept the implementation of non-financial measures and VSC when they can continue to use measurements of labor and materials efficiency as an anchor of performance measurement. Thus, to comprehensively assist employees with information and drive behavior in a lean-congruent manner, lean visual controls are dependent on VSC and measurements of labor and materials efficiency, which makes them mutually dependent. Thus, we hypothesize the following:

H1g: VSC, lean visual controls, and measurements of labor and materials efficiency are interdependent.

11.2.2 Hypotheses 2a–2d

Implementation of lean manufacturing includes a focus on standardization of production processes, pull production and single-piece flow, mistake proofing devices, and interaction with suppliers (Liker 2004; Shah and Ward 2007). These practices are introduced to eliminate waste, increase efficiency, and create quality products and value for and according to customer demand (Womack et al. 1990). When initiating lean manufacturing, companies experience improved operational

performance (Fullerton et al. 2014; Jayaram et al. 2010) such as reduced inventories (Hofer et al. 2011; Maiga and Jacobs 2008; Netland et al. 2015), improved lead time and quality (Khachanapong et al. 2014), and improved flexibility (Bortolotti et al. 2014).

As indicated, lean manufacturing comprises several related practices (Fullerton et al. 2013; Shah and Ward 2007; Womack and Jones 2003). Lean manufacturing depends heavily on visual controls, as information on standards, deviations from standards, quality, and flow are essential (Liker 2004). Likewise, visual controls highlight potentials for continuous improvement; ensure alignment between lean objectives and operational processes; and direct employees' attention to operational issues needing action (Womack and Jones 2003). Furthermore, by sharing information through visual controls such as floor markings indicating material and work flow, lean manufacturing firms can increase the internal and global transparency (Adler and Borys 1996). This reduces the risk of sub-optimizing work behavior and provides employees with the best work practices. Current standards are founded on the best practices currently known, and once made visible to all these current standards provide the baseline for continued improvement. If employees follow the visuals depicting current standards and use the visual information aligned with lean objectives, it is likely that they will contribute to operational improvement. Fullerton et al. (2014) found a positive relationship

between visual controls and operational performance and Flynn et al. (1994) found a positive relationship between visual charts and quality performance.

Lean thinking is internalized in employees' and management's mindsets (Liker 2004). This is accomplished by training employees and management in lean principles, continuous improvement, and problem solving and by encouraging them to go to the genba. This, in turn, will improve employees' and managers' lean capabilities and will enable them to identify potential improvements and deliver continuous improvement, leading to improved operational performance (Emiliani et al. 2003). Also, by internalizing lean thinking, employees and management will be able to identify and solve the root cause of problems instead of correcting symptoms or outcomes of problems (Liker 2004). This reduces the risk of recurring problems. Thus, lean thinking is a catalyst for operational improvements.

Additionally, we argue that operational performance is positively associated with financial performance. Lean manufacturing firms are likely to capitalize on improvements in quality and cycle time, reduced inventory, and more efficient capacity management. Thus, when firms improve operational performance, improvements in financial performance should follow (Sila 2007). Fullerton et al. (2014) and Bortolotti et al. (2014) found that operational performance was positively associated with financial performance. Likewise, Hofer et al. (2011)

found that inventory leanness (operational performance) was positively associated with financial performance. Also, a reduction in cycle time (operational performance) is linked to improvements in financial performance (Kim et al. 2002).

The following four hypotheses sum up the relationships between lean manufacturing, lean thinking, lean visual controls, operational performance, and financial performance:

H2a: Lean manufacturing is positively associated with operational performance.

H2b: Lean visual controls are positively associated with operational performance.

H2c: Lean thinking is positively associated with operational performance.

H2d: Operational performance is positively associated with financial performance.

11.2.3 Hypotheses 3a–3b

Dierickx and Cool (1989) introduced the concept of time compression diseconomies. They exemplified it with MBA students: MBA students enrolled in a one-year program may not accumulate the same stock of knowledge compared to MBA students in a two-year program even if all inputs other than elapsed time are doubled. We argue that time compression diseconomies reasonably hold for lean companies as well. Time compression diseconomies are quite similar to the law of diminishing returns and can be explained by absorptive capacity (Cohen and Levinthal 1990). Cohen and Levinthal (1990) described absorptive capacity as firms' ability to recognize information, internalize it, and apply it to commercial ends. The premise underlying absorptive capacity is that firms need prior *related* knowledge to assimilate and use new knowledge. This means that building new knowledge is cumulative and that knowledge building performance is greatest when the object of concern is already known. Consequently, knowledge building is more difficult and lengthy in novel domains, such as when companies leave their current production regime and implement lean manufacturing. Nelson and Winter (1982) emphasize that organizational members learn and remember by doing. Therefore, by repeatedly performing work processes, going to the genba, engaging in training, problem solving, and continuous improvement, members of a lean manufacturing organization will learn and remember what worked and what did

not, and they will improve their lean capabilities over time. This applies to skills and knowledge gained from experiences prior to lean as well; employees can have gained experience, skills, and knowledge from periods prior to the introduction of lean manufacturing in their company, some of which they now need to unlearn (Åhlström and Karlsson 1996). This proceeds through several lengthy stages (Hines et al. 2004), and “experience that comes too fast can overwhelm managers, leading to an inability to transform experience into meaningful learning” (Eisenhardt and Martin 2000, 1115). There is not much research on how the length of time companies have used lean manufacturing affects operational performance. Callen et al. (2000) reported that early adopters of JIT outperformed later adopters on reducing work-in-progress inventory, reducing costs, and improving profits. However, they did not control for the extent of JIT. As such, we do not know whether the higher performance obtained by early adopters is a function of learning and fine-tuning of JIT or if it is a function of the early adopters having implemented JIT to a greater extent.

As stated in hypotheses 2a–2c, we predict positive relationships between lean manufacturing, lean thinking, lean visual controls, and operational performance. Motivated by the arguments above, length of time companies have used lean manufacturing moderates these relationships and we hypothesize that the operational performance effects are greater for companies that having used lean

manufacturing for a longer period of time. Lean manufacturing includes a restructuring of the production area into cells; investments in and intensive use of visual controls; a change in the mindset of employees and management; new procedures, structures, and principles; and the empowerment of employees, all of which take time to work out and fine-tune. For our argument on time compression diseconomies to hold, it is necessary to control for differences in the extent of lean manufacturing, lean visual controls, and lean thinking. This is done to ensure that the hypothesized greater operational performance effects are a function of the length of time companies have used lean manufacturing, and not differences in the extent of these three variables. Arguing for an ordinal difference in the form of the relationships (Hartmann and Moers 1999), we hypothesize the following:

H3a: The hypothesized positive relationships between lean manufacturing, lean visual controls, and lean thinking with operational performance are higher as a function of the duration of companies' experience with lean manufacturing.

Time compression diseconomies concern possible differences in outcomes when the same amount of "input" is either intensified in a short period or less intensified in a longer period. This cannot explain why a relationship between lean manufacturing measurements of direct labor and materials efficiency is higher as a

function of the duration of companies' experience with lean manufacturing. There is little empirical evidence on how more/less experience with lean manufacturing affects the relationship between lean manufacturing and management accounting practices. The evidence that we know of compares management accounting practices in companies before and after a lean manufacturing implementation (e.g., Lind 2001; Kennedy and Widener 2008). However, measurements of labor and materials efficiency are ubiquitous in conventional production management controls systems and are most certainly already in place before lean manufacturing is implemented. We should see a less intensive use of labor and materials efficiency variances in the initiating periods of a lean manufacturing implementation due to the fact that the adoption and use of VSC and lean visual controls absorb employees' attention and cognitive capacity, as these systems need to be properly installed and aligned with lean manufacturing. We thus hypothesize the following:

H3b: The relationship between lean manufacturing and labor and materials efficiency variances is greater as a function of the length of time companies have used lean manufacturing.

Our research model is depicted in figure 1.

Figure 1: research model

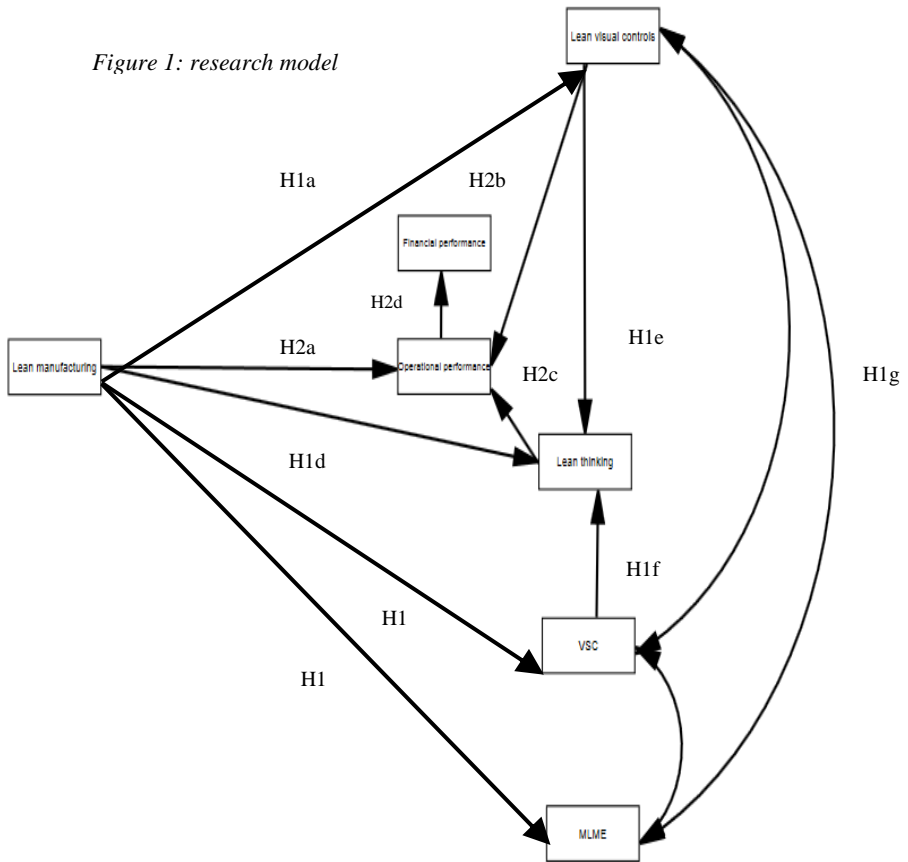

11.3 Methods

The survey was distributed online to 4,357 people representing 697 facilities and plants in September 2012 and responses were received until December 2012. The people were identified in the Shingo Prize⁵⁸ Organization database of individuals who had expressed an interest in receiving information about lean principles, Shingo seminars and workshops, and the Shingo Prize. We received responses from 510 individuals representing 368 different facilities, which resulted in a response rate of 11.2%. We averaged responses from plants that submitted multiple responses, leaving us with a usable sample size of 368 and a facility response rate of 52.8%. Collectively, the 368 facilities represented 195 different organizations. More than 50% of the facilities had more than 500 employees and sales of more than \$100M. The large majority of respondents had management experience; 53.5% of the respondents were responsible for lean, quality, or continuous improvement or were plant managers. Survey questions were designed to assess the lean manufacturing and management accounting implementation at the respondents' facility and obtain a self-assessment of operational and financial performance.

⁵⁸ The Shingo Prize is an award given to companies based on their world-class results and organizational culture. The database includes many companies as the Shingo Prize Organization provides information and sponsors seminars as well as running the prize competition, and most organizations do not wait to challenge for the Shingo Prize until they are likely to win it.

11.3.1 Measures

While the questionnaire included 148 questions, we only included those of interest for our analysis in the present article. Six items measuring lean manufacturing were adapted from Fullerton et al. (2013; 2014). Two additional items (item 6 and 8) were included and are consistent with lean literature, e.g., Liker (2004) and Shah and Ward (2007). Six of the seven items measuring lean visual controls were adapted from Fullerton et al. (2013; 2014) and item 1 is included in accordance with Kennedy and Widener (2008).

One of the items (item 1) measuring lean thinking was adapted from Fullerton et al. (2013),⁵⁹ while the remaining four items are developed on the basis of Emiliani et al. (2003). Items reflecting operational performance are developed to cover the extent to which lean initiatives have affected inventory resources, capacity management, cycle time, quality, and communication. The two items measuring financial performance reflect cost reduction and profitability improvement. Along with these items, we include two items covering two observed variables: VSC and measures of direct labor and materials efficiency (i.e., labor and materials efficiency variances). While most variables used in a structural equation model are latent, it is acceptable to use observed variables (Kline 2005) when they are narrow

⁵⁹ This item was part of their empowerment factor.

and unambiguous to the respondents (Sacket and Lawson 1990; Wanous et al. 1997). As the sample represents individuals connected to the Shingo Prize, we argue that they understand the following formulation: “Please indicate the extent to which your facility uses value stream costing.”⁶⁰ The variable is measured on a 5-point Likert scale ranging from 1 (not at all) to 5 (to a great extent). Measurements of labor and materials efficiency were measured in the same way.

All other variables were measured on a 5-point labeled Likert scale as well. Eustler and Lang (2015) have shown that such labeled scales are superior to unlabeled scales, as they reduce measurement error and response bias.

11.3.2 Exploratory factor analysis

Initially, we conduct an exploratory factor analysis with oblique rotation, as we expect our factors to correlate, including our exogenous and mediator variables. It yields three factors with eigenvalues more than 1 in conformity with our *a priori* expectations: lean manufacturing, lean visual controls, and lean thinking. The three factors collectively explain 65 percent of the variance. Factor analysis is performed for the performance items as well. We follow Venkatram and Ramanujam (1986) and divide performance into two dimensions measuring operational and financial performance, which provides us with a “comprehensive operationalization of

⁶⁰ Fullerton et al. (2013; 2014) measured VSC in the same way.

business performance” (p. 811) and both a goal-centered and an accounting approach (Kihn 2005). Furthermore, separating operational and financial performance will reduce the number of threats to the validity of the research design and uncover underlying types of performance that may be in conflict (Venkatram and Ramanujam 1986). The factor analysis yields two factors; operational and financial performance, which explain more than 70 percent of the variance⁶¹. All of the factors’ Cronbach’s alphas are generally between .8 and .91 (see Table 2), indicating very good to excellent reliability (Kline, 2011).

To reduce common method bias concerns, we perform a Harman’s one-factor test that includes all our latent variables. There is a potential bias if the majority of the variance is explained by one factor (Podsakoff and Organ 1986). The test shows that the concern for common method bias is low, as a one-factor solution only accounts for 46 percent of the total variance.

⁶¹ In addition to the argument made, it makes empirical sense to force two constructs, as Fullerton and Wempe (2009) and Hofer et al. (2011) showed that operational performance mediated the relationship between lean manufacturing and financial performance. Furthermore, we ran a test comparing a model containing only one performance factor, including all items, and a model comprising two factors, operational and financial performance, by constraining their correlation to 1. This is done in order to investigate whether a two-factor model fits the data better compared to a one-factor model. A two-factor model is appropriate if χ^2/df^{Diff} is significant (Hair et al. 2014). The model comprising two factors fitted the data significantly better: χ^2 difference: 68.166, degrees of freedom difference: 2, resulting in a χ^2/df^{Diff} p. < 0.001 and the following fit indices: RMSEA: .055, SRMR: .113, IFI: .948, TLI: .942, CFI: .948. The operational performance factor has an eigenvalue of more than 5 and the eigenvalue of the financial performance factor is 0.66.

Table 1: Exploratory factor analysis and descriptive statistics

Indicators	Factor 1: lean MFG	Factor 2: lean Thinking	Factor 3: lean VIS	Factor 4: Opr pfm	Factor 5: Fin pfm	Mean	Std.deviation
MFG1	0.429					3.86	.83
MFG2	0.698					3.65	1.08
MFG3	0.794					3.52	1.07
MFG4	0.820					3.27	1.11
MFG5	0.869					3.28	1.08
MFG6	0.850					3.51	1.06
MFG7	0.620					3.36	1.01
MFG8	0.573					3.44	.99
CLTR1		-0.681				3.34	.95
CLTR2		-0.837				3.40	1.08
CLTR3		-0.884				3.44	1.05
CLTR4		-0.836				3.51	1.01
CLTR5		-0.779				3.18	1.08
MAS1			0.69			3.68	0.94
MAS2			0.704			4.08	0.88
MAS3			0.744			4.13	0.85
MAS4			0.886			3.72	1.07
MAS5			0.698			3.40	1.05
MAS6			0.895			3.67	1.08
MAS7			0.797			3.37	1.08
LIMP1				0.870		3.24	.95
LIMP2				0.888		3.60	.87
LIMP3				0.814		3.73	.88
LIMP 4				0.749		3.64	.86
LIMP5				0.737		3.63	.85
LIMP7					-0.947	3.60	.89
LIMP8					-0.936	3.54	.91
VSC	N/A					2.74	1.19
MLME	N/A					3.83	1.01
LMFGY	N/A					8.60	5.15

KMO of sampling adequacy for lean MFG, lean CLTR and lean VIS: .953, Bartlett's test of sphericity p. <.000
KMO of sampling adequacy for Opr Pfm and Fin Pfm: .887, Bartlett's test of sphericity p. <.000
Only loadings exceeding .400 are shown

Along with the observed variables VSC and MLME, these factors represent the variables used in our research model.

11.3.3 Confirmatory factor analysis

We perform a confirmatory factor analysis that includes our latent factors in Amos 23 using maximum likelihood estimation. Hair et al. (2014) describe this as a two-step procedure where the measurement model without structural paths is tested initially to ensure that it fits, which is then followed by the full structural model. The test of the measurement model did not reveal any theoretically or empirically justified covariances between error terms of the same factor.

We evaluate the measurement model using several fit indices, as recommended by Kline (2011). We assess χ^2 to degrees of freedom, which should be lower than two (Bollen 1989; Kline 2011), the root mean square error of approximation (RMSEA) (Steiger and Lind 1980), where values below .08 are acceptable (Browne and Cudeck 1993; Kline 2011), and the standardized root mean square residual (SRMR) (Bentler 1995), where a value below .1 indicates acceptable fit (Schermelleh-Engel et al. 2003). Furthermore, we evaluate the comparative fit index (CFI) (Bentler 1990), the incremental fit index (IFI) (Bollen 1989), and the Tucker-Lewis index (TLI) (Tucker and Lewis 1973). CFI, IFI, and TLI are evaluated for their closeness

to 1.0 (Byrne 2010) with values over .9 (Bentler 1992; Kline 2005) indicating acceptable fit. Lastly, we evaluate the Akaike information criterion (AIC) (Akaike 1987), where the ratio of the hypothesized model and the saturated model should be less than one (Kline 2011). Although the χ^2 is significant, the χ^2 to degrees of freedom is less than two and other fit indices are good.

Table 2: Confirmatory factor analysis, Chronhach's alpha and composite reliability

Construct indicators	Standardized loadings	T-value (All significant p.<.01)	C.R	Alpha
<i>lean Manufacturing</i>			0.904	0.903
MFG1	0.65	11.80		
MFG2	0.64	8.85		
MFG3	0.75	10.71		
MFG4	0.78	10.68		
MFG5	0.76	10.91		
MFG6	0.78	11.36		
MFG7	0.76	a*		
MFG8	0.75	11.48		
<i>lean Thinking</i>			0.905	0.904
CLTR1	0.71	16.07		
CLTR2	0.78	16.98		
CLTR3	0.84	19.53		
CLTR4	0.83	19.69		
CLTR5	0.89	a		
<i>lean Visual Controls</i>			0.907	0.905
MAS1	0.71	a		
MAS2	0.77	10.56		
MAS3	0.83	9.33		
MAS4	0.78	8.95		
MAS5	0.82	9.12		
MAS6	0.77	8.15		
MAS7	0.65	9.33		
<i>Operational Performance</i>			0.885	0.881
LIMP1	0.74	a		
LIMP2	0.83	12.97		

LIMP3	0.85	13.09		
LIMP4	0.75	11.73		
LIMP5	0.72	11.37		
<i>Financial Performance</i>			0.900	0.900
LIMP6	0.92	a		
LIMP7	0.89	20.32		

*"a" indicates a loading fixed to 1.

χ^2 to degrees of freedom 1.906, RMSEA: .050, SRMR: .042 CFI: .958, IFI: .958, TLI: .953 and AIC: .96 (780.628/810.000 saturated model)

To assess construct validity, we investigate our CFA's convergent validity, construct reliability, and discriminant validity. All our factors show good convergent validity, as their average variance extracted (AVE) is above .5 and their construct reliability (CR) is well above .7 (Hair et al. 2014). Furthermore, as indicated in Table 2, all factor loadings except for three are above .7. Discriminant validity is assessed by comparing the square root of the AVE of the factors with their correlation (Fornell and Larcker 1981). Square root AVE of individual factors should be greater than the correlation between the factors. Square root AVE of factors is indicated at the diagonal of Table 3 and is greater than factor correlations⁶². Table 3 also indicates that all factors correlated significantly as

⁶² Squared AVE to inter-factor correlations is computed in SPSS 23. We compared the squared AVE to the inter-factor correlations in AMOS 23 as well. This test revealed discriminant validity issues only concerning the operational performance factor and the lean flow factor. All of our factors correlated less than .85. Thus, they do not indicate poor discriminant validity (Kenny 2012). Kenny (2012) also suggests restricting the correlation between two factors to 1. We performed a test where we restricted correlations between the operational performance and the lean manufacturing factor. A two-factor model fits the data

expected. Additionally, we test the measurement model for multicollinearity. None of the variance inflation factors exceed 2.1 and the tolerance statistics all exceed a critical value 0.2 (Menard 1995). Thus, our model does not indicate multicollinearity concerns. Before running the full structural model, we also test all relationships from exogenous to mediator variables and from mediator variables to endogenous variables for linearity. All relationships are significantly linear $p < .01$ and have R^2 values ranging from .215 to .531 and F-values between 100 and 452.

Now we will proceed to evaluate the full structural model fit.

Table 3: Variable correlations and squared average variance extracted.

	# of measures	1	2	3	4	5	6	7
lean Manufacturing	8	0.736						
lean Thinking	5	.603***	0.811					
lean Visual Controls	7	.617***	.653***	0.764				
Operational Performance	5	.725***	.722***	.692***	0.779			
Financial Performance	2	.623***	.604***	.552***	.729***	0.905		
VSC	1	.498***	.474***	.436***	.427***	.367***	N/A	
MLME	1	.453***	.383***	.457***	.421***	.399***	.349***	N/A

*** significant at the .01 level (two-tailed)

Square roots of AVE are shown at the diagonal

significantly better than a one-factor model: χ^2 difference: 69.9 and degrees of freedom difference: 2 resulting in a $\chi^2/df^{Diff} p < 0.01$. We assess the fit indices of the one-factor model as well. They are worse compared to the two-factor model: RMSEA: .055, SRMR: .1207, IFI: .948, TLI: .942, CFI: .948.

11.4 Results

11.4.1 Structural model

All fit indices of the structural equation model indicate a good fit to the data. Although the χ^2 is significant, the χ^2 to degrees of freedom is less than two (1.855), indicating acceptable model fit. IFI, TLI, and CFI either equal or exceed .951, RMSEA is .048, and SRMR .is 041, indicating great model fit. Furthermore, AIC is lower for the default model compared to the saturated model (.94), indicating parsimony.

11.4.2 Test results of hypotheses 1a–2d

Table 4 presents the results of hypotheses 1a–2d. All hypotheses (1a–2d) are supported at a p-value at $\leq .05$ and all directions are as expected.

We find that lean manufacturing is positively related to lean visual controls and VSC. Lean manufacturing is also positively associated with lean thinking. This underlines that lean manufacturing includes a focus on and training in continuous improvement, empowerment of employees, and an internalization of lean principles among employees and management (Emiliani et al. 2003). Both VSC and lean visual controls are positively associated with lean thinking. This is important because it shows that both financial and non-financial measures can comprehensively assist employees and management in developing their lean

mindset and their focus on continuous improvement and problem solving. Lean manufacturing is positively associated with measurements of labor and materials efficiency. This finding contributes to the debate on standard costing in lean manufacturing companies, as it shows that lean manufacturing companies do not abandon the use of these measures and also indicates that lean companies use a wide portfolio of both financial and non-financial performance measurements.

We also find that lean manufacturing is positively associated with operational performance. Lean visual controls are also positively related to operational performance. Therefore, by sharing information regarding takt time, best practices, quality, productivity, and defects, lean visual controls increase employees' and managers' work attention to production flow and emergent issues, which, in turn, improves operational performance. Lean thinking is positively associated with operational performance as well. This is expected, as lean thinking improves employees' and managers' lean capabilities and enables them to identify potential for and perform continuous improvement leading to improved operational performance (Emiliani et al. 2003). Additionally, operational performance is positively associated with financial performance. Thus, lean manufacturing firms do utilize operational performance improvements to improve profitability.

We test for interdependency among VSC, measurements of labor and materials efficiency, and lean visual controls (Grabner and Moers 2013). As indicated in Table 4, panel A, there are positive, significant relationships between VSC and lean visual controls, measurements of labor and materials efficiency and lean visual controls, and measurements of labor and materials efficiency and VSC, indicating that they are interdependent. This supports our argument that the value of VSC and measurements of labor and materials efficiency are reduced if they are not visualized and that employees and managers need financial as well as non-financial information to support their implementation of lean manufacturing.

Table 4: Results. Panel A: Direct relationships; Panel B: Indirect relationships

Panel A			Hypotheses	Expected sign	Coefficient	T-value
Relationships						
lean manufacturing	-->	lean Visual Controls	H1a	+	0.685	10.584***
lean manufacturing	-->	MLME	H1b	+	0.489	9.261***
lean manufacturing	-->	VSC	H1c	+	0.517	9.830***
lean manufacturing	-->	lean thinking	H1d	+	0.317	4.956***
lean visual controls	-->	lean thinking	H1e	+	0.432	6.740***
VSC	-->	lean thinking	H1f	+	0.136	2.986**
MLME	<-->	VSC	H1g	+	0.129	2.365**
MLME	<-->	lean visual controls	H1g	+	0.218	3.491***
VSC	<-->	lean visual controls	H1g	+	0.156	2.546**
lean Manufacturing	-->	Operational performance	H2a	+	0.460	7.763***
lean Visual	-->	Operational performance	H2b	+	0.199	3.624***
lean Thinking	-->	Operational performance	H2c	+	0.341	6.076***
Operational performance	-->	Financial performance	H2d	+	0.820	13.634***

Panel B				
Independent variable	Dependent variable	Direct effects	Indirect effects	Total effects
lean manufacturing	Operational performance	0.460***	0.370***	0.830***
lean manufacturing	lean thinking	0.317***	0.366***	0.683***

lean visual controls	Operational performance	0.199***	0.148***	0.347***
VSC	Operational Performance	-0.074*	0.05**	0.025

***Significance of the p. value at <.01 two tailed, **Significance of the p. value at <.05 two tailed. *significance of the p. value at <.10 two tailed. χ^2 to degrees of freedom 1.845, RMSEA: .048, SRMR: .041, CFI: .956, IFI: .956, TLI: .951 and AIC: .938 (871.093/928.000 saturated model).

We assess the indirect effects⁶³ as well (see figure 2 and table 4, panel B). Lean visual controls are positively related to operational performance through lean thinking. Lean manufacturing is positively related to operational performance through lean thinking and lean visual controls, and positively associated with lean thinking through lean visual controls. These results leave us with important insights: not only do lean manufacturing and lean visual controls affect operational performance directly, they intervene as well (Luft and Shields 2007), resulting in a larger total effect on operational performance. Finally, VSC is positively related to operational performance through lean thinking. Taken together, these results indicate that lean thinking works as a catalyst for improved operational performance.

⁶³ We perform a boot-strapping procedure with 2,000 samples and use the bias-corrected confidence intervals in AMOS 23 when we test for significance of indirect effects. Amos demands that missing values are replaced; we use the expectation maximization method.

Figure 2: Results model

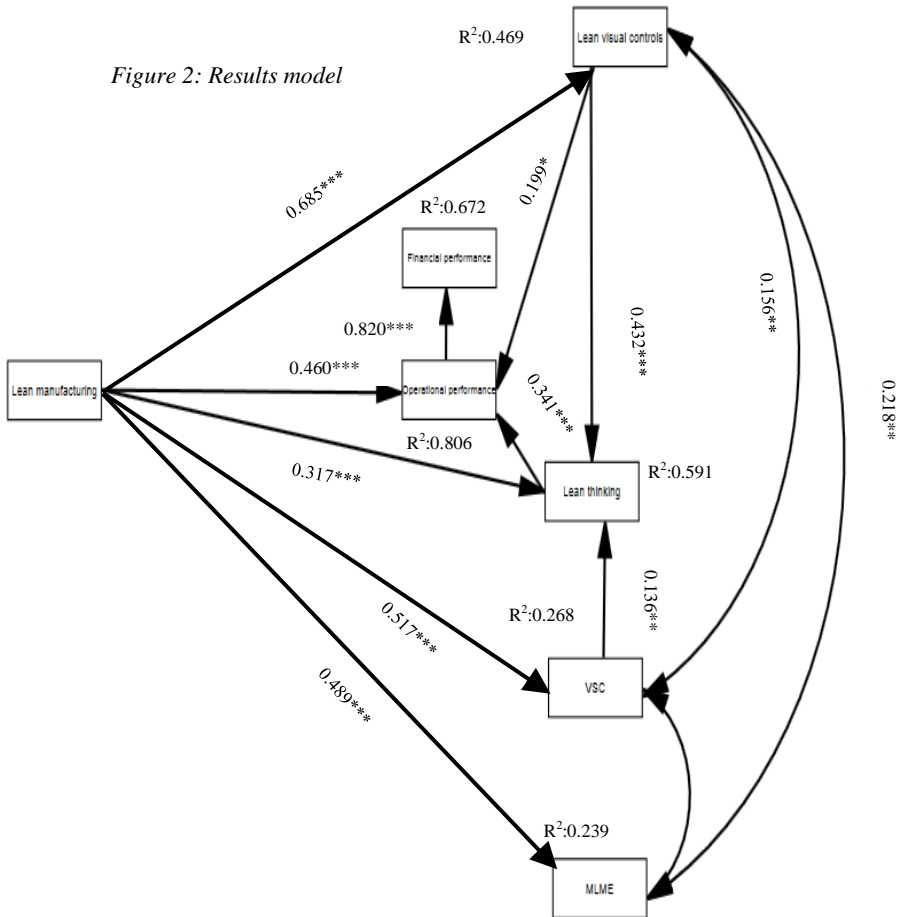

11.4.3 Test of hypothesis 3

To test for hypothesis 3, we split the data at the median length of time companies have used lean manufacturing, dividing the total sample into two sub-samples (0 = lean manufacturing ≤ 8.5 years, n=178, 1 = lean manufacturing > 8.5 years, n=190). Before we test the differences of the structural paths, we need to make sure that the

measurement model is invariant across subgroups (Deng et al. 2005). We compare a model without structural parameters restricting all factor loadings to be equal across subgroups with a model where all factor loadings vary freely. We use a $\chi^2/\text{df}^{\text{Diff}}$ test to compare the measurement model across subgroups. If χ^2 is significant, it is an indicator of model variance. The measurement model is invariant across our subgroups (p. 0.46). Next, we compare a model where all parameters (including structural parameters) are restricted to be equal across subgroups to a model where all these parameters vary freely (Hu and Bentler 1999; see also Fullerton et al. 2013). For our hypotheses to hold, the $\chi^2/\text{df}^{\text{Diff}}$ needs to be significant, indicating that the model is non-invariant across subgroups.

We find that the duration of respondents' experience with lean manufacturing functions as a moderator with a χ^2 difference of 120.240 (p. 0.06). To gain further evidence of moderated relationships, we investigate every individual parameter of the model by constraining all parameters except the parameter of our interest and test for χ^2 difference. Lean manufacturing to operational performance is significantly different between subgroups p. < 0.05 (0 = unstandardized estimate: .325, 1 = unstandardized estimate: .398). To control for differences in the extent of lean manufacturing, we compare means and variances of the lean

manufacturing factor in the subgroups. These are not significantly different⁶⁴. This provides an important insight, as lean manufacturing not only improves operational performance, but the marginal effect is moderated positively by the duration of companies' experience with lean manufacturing. Thus, as time goes on, the lean manufacturing practices become more fine-tuned and employees and management reap more benefits from them. This finding is in line with Nelson and Winter's (1982) argument that new procedures and practices take time to be perfected. Likewise, it is an indication of a limitation of employees' and management's absorptive capacity (Cohen and Levinthal 1990). The finding also documents that lean manufacturing firms are not just cherry picking easy performance improvements, as they also develop their lean capabilities over time.

The relationship between lean visual controls and operational performance is marginally significantly different between the subgroups as well (p. 0.06) (0 = unstandardized estimate: .138, 1 = unstandardized estimate: .204), indicating that the longer companies have worked with lean manufacturing, the more employees act and react accordingly to and understand the non-financial information provided by visual boards. It also indicates that, with time, the visualized information is

⁶⁴ Difference of lean manufacturing between subgroups: variance (p-value 0.696) and mean (p-value 0.100) of lean manufacturing are not statistically different. Additionally, we tested for main effects in both our subgroups by incorporating the observed variable "lean manufacturing years" in our model and related it to operational performance. The relationship was not significant.

more fine-tuned to the lean implementation. We controlled for differences in the extent of lean visual controls between subgroups. Neither mean nor variance is statistically different⁶⁵.

The relationship between lean manufacturing and measurements of labor and materials efficiency is significantly different between subgroups $p. < 0.05$ (0 = unstandardized estimate: .537, 1 = unstandardized estimate: .728)⁶⁶. As such, lean manufacturing companies intensify their use of measurements of labor and materials efficiency as a function of the duration of their experience with lean manufacturing rather than abandoning them. This result indicates that, in the beginning of a lean manufacturing implementation, companies place less emphasis on measurements of labor and materials efficiency, as they need to adopt other non-financial performance measures and VSC and put them into use, which absorbs employees' attention and cognitive capacity⁶⁷.

⁶⁵ The difference in lean visual controls between subgroups: variance (p. 0.282) and mean (p. 0.910) of lean visual controls.

⁶⁶ We tested for main effects in both our subgroups by incorporating the observed variable "lean manufacturing years" in our model and related it to MLME. The relationship was not significant.

⁶⁷ The unstandardized beta-coefficient was also marginally significantly different at p. 0.06 one-tailed.

Table 5: The length companies have used Lean manufacturing as a moderator

Variable relationship	Hypotheses	Years implemented lean manufacturing		Significant paths unrestricted and restricted models
		≤ 8.5years	> 8.5 years	
lean manufacturing --> Operational performance	H3a	0.325***	0.398***	**
lean visual Controls --> Operational performance	H3a	0.138*	0.204**	*
lean thinking --> Operational performance	H3a	0.230***	0.205***	n/s
lean manufacturing --> MLME	H3b	0.537***	0.728***	**
Model comparison	X2	Df	p. value	
Unrestricted model	1151.31	732		
Restricted model	1271.55	830		
X2 difference			0.06	

***Significance of the p. value at <.01 two tailed

**Significance of the p. value at <.05 two tailed

*Significance of the p. value at <.10 two tailed

Group 0: ≤ 8.5 years implemented lean manufacturing n= 178, group 1: > 8.5 years implemented lean manufacturing n= 190.

Coefficients reported are unstandardized

11.4.4 Test of an alternative model

To test another plausible explanation of the variation in dependent variables and strengthen the validity of our model (Van der Stede 2014), we decided to test a model where we included activity-based costing (ABC). Ittner et al. (2002) found that ABC was positively associated with advanced manufacturing procedures,⁶⁸ improved product quality, and led to reductions in cycle and lead time, which resulted in improved financial performance. Cagwin and Bouwman (2002) found that the relationship between ABC and ROI was insignificant; however, they found

⁶⁸ According to Ittner et al. (2002), “advanced manufacturing procedures” is an umbrella term incorporating JIT, total quality management (TQM), and cell-based production.

that JIT was positively related to ABC. Thus, existing empirical literature indicates a positive association between lean manufacturing and ABC and between ABC and operational performance, while evidence of the relationship between ABC and financial performance seems mixed. Both Kaplan and Cooper (1998) and Turney and Stratton (1992) argue that ABC can support firms employing a continuous improvement program, as ABC can reveal cost reduction potential (e.g., reflecting costs of the setup-procedure of a machine or reflecting movement/transportation costs) and direct employees' attention to improvement possibilities, thereby inducing lean thinking. However, Johnson (1992) and Grasso (2005) argue that ABC is not appropriate in lean manufacturing companies. Some of the critiques related to standard costing, e.g., that it hides waste in standards and induces incongruent lean behavior, apply here as well. Likewise, Grasso (2005) contends that ABC is not a driver of continuous improvement efforts. We address this debate and test a model where we include ABC⁶⁹ and add paths from ABC to lean thinking and to operational and financial performance; none of the parameters are significant and model fit is worse⁷⁰. This finding indicates that VSC, lean visual controls, and measures of labor and material efficiency are adequate performance

⁶⁹ The degree of ABC use is measured on a 5-point labeled Likert scale ranging from 1: not at all to 5: to a great extent.

⁷⁰ χ^2 to degrees of freedom: 1.992, RMSEA: .052, SRMR: .044, IFI: .946, TLI: .940, CFI: .946. χ^2 difference: 99.956, DF difference: 25, χ^2/df^{Diff} significant at a p. < .01, indicating that the model including ABC fits the data worse.

measures regarding lean manufacturing. One can speculate that lean manufacturing companies have already performed much of the process analysis that ABC can support⁷¹. Lean manufacturing also reduces cost allocation requirements and the product heterogeneity that ABC is designed to address (Grasso 2005). Our performance variables relate to operational and financial performance. Although we do not find any significant relationships, ABC might still support strategic issues, such as choosing customer/product mix. These elements are not captured in our questionnaire.

11.5 Conclusion

Lean pundits suggest that management accounting practices should be aligned with the implementation of lean manufacturing in order to achieve its potentials. Some advocate that direct labor and materials efficiency variances should be abandoned because of inherent dysfunctional behavioral consequences for the lean implementation (Maskell and Kennedy 2007; Maskell et al. 2012). Instead, measurements of direct labor and materials efficiency should be replaced with an expanded focus on non-financial performance measurements and an implementation of VSC. They also underline the importance of a change in employees' and managers' mindsets in order for them to work toward the lean objectives (Emiliani et al. 2003; Fullerton et al. 2014). This study provides

⁷¹ Additionally, we performed the same test on the subgroups according to the number of years they had lean manufacturing. None of the paths were significant.

empirical evidence of the relationships between lean manufacturing, management accounting practices, lean thinking, and firm performance. We use three components representing management accounting practices: VSC, lean visual controls, and measurements of direct labor and materials efficiency. Lean manufacturing is positively related to all management accounting practices, lean thinking, and operational performance. Further, the management accounting practices are interdependent; lean visual controls are positively related to operational performance and lean thinking; and VSC is positively related to lean thinking, which, in turn, is positively related to operational performance—which ultimately leads to improved financial performance. Importantly, lean manufacturing is indirectly related to operational performance through VSC, lean visual controls, and lean thinking. Thus, these two components of the management accounting practices and lean thinking enhance the operational benefits from lean manufacturing. Lean visual controls and VSC are also indirectly related to operational performance through lean thinking, which underlines that lean thinking is a catalyst for firms to achieve the potentials of lean manufacturing. Overall, it is apparent that a holistic perspective is required to grasp the interrelatedness of lean manufacturing, lean thinking, visual controls, multiple management accounting practices, and their effects on performance. As previously mentioned, we provide the first survey-based evidence that more traditional management accounting

practices, such as measurements of direct labor and material efficiency, supplement contemporary practices, such as VSC and visual controls, rather than substituting them.

This study also provides empirical evidence of time compression diseconomies (Dierickx and Cool 1989) in lean manufacturing companies. The relationship between lean manufacturing and operational performance and the relationship between lean visual controls and operational performance are greater as a function of the length of time companies have used lean manufacturing. Further, when companies become more experienced with lean, they emphasize measurements of direct labor and materials efficiency to a greater extent.

These findings provide substantial insights for research. Contrary to the lean accounting research consensus, our sample of lean manufacturing firms does not abandon measurements of direct labor and materials efficiency. In the beginning of an implementation of lean manufacturing, our sample of companies place less emphasis on these measures as they adopt, focus, and fine-tune their use of VSC and lean visual controls. However, as they gain experience with VSC and lean visual controls, the companies intensify their use of measurements of labor and materials efficiency. This can be a reflection of an increased need for measures showing unit-level cost improvements and a reflection of a cognitive limitation of

employees and management as they, in the beginning of a lean manufacturing implementation, pay more attention to the use and fine-tuning of other management accounting practices. Measurements of direct labor and materials efficiency are also interdependent with VSC and lean visual controls, indicating that lean manufacturing companies need comprehensive visualized performance information to inspire employees and managers and to ensure that they are on par with lean objectives.

Our research also shows that lean thinking is a catalyst in providing firms with the benefit from lean manufacturing. It underlines the importance of getting all organizational members involved in lean by training them in continuous improvement, by changing their mindsets, and by providing them with the responsibility and authority to identify potential improvements and to solve problems. The implementation of lean manufacturing is thus not only an exercise of implementing and aligning management accounting practices and lean manufacturing practices; it is an effort that requires the attention of all aspects of a firm.

Our research is the first to show evidence of time compression diseconomies in lean manufacturing firms. After controlling for the extent of use, the firms in our sample benefit more from lean manufacturing and lean visual controls as a function

of the length of time they have used lean manufacturing. Although firms benefit from lean manufacturing and lean visual controls early in the implementation, our results show signs of the limitations of employees' and managers' absorptive capacity. Additional benefits from lean manufacturing and lean visual controls materialize when members of the organization become more experienced with lean practices and procedures. The results also indicate that members of the organization need to unlearn previous practices and procedures to benefit to a greater extent from lean manufacturing and lean visual controls.

Our results have implications for lean practitioners as well. Firms seeking to benefit from lean manufacturing do not need to abandon the use of measurements of labor and materials efficiency. This can alleviate some of the possible tensions between management accountants and manufacturing personnel resulting from the intention to abandon traditional management accounting practices (Tillema and van der Steen 2015). Another implication of our research for lean practitioners is that success with lean manufacturing is not only a function of extending the implementation, but also a function of patience and learning to work with the current extent of lean implementation. This implies that time and patience are important for practitioners as additional investments in lean practices. Finally, our evidence shows that practitioners need to get every employee involved in lean thinking to achieve the full potentials of lean manufacturing.

11.6 Limitations and future studies

Naturally, our study has its limitations. Our sample is not random, as it is drawn from a database consisting of companies employing lean manufacturing. This reduces the generalizability of our findings. However, it also alleviates some of the inherent problems that come with questionnaire research, as we believe that it improves our respondents' understanding of lean-related questions (Fullerton et al. 2013). Further, our data was gathered during a time of general industrial expansion following a severe recession, so the results may not be generalizable to other macroeconomic conditions.

For now, we have little empirical evidence on how standard costing can work together with lean management accounting practices and this study only focused on labor and materials efficiency variances. We call for further in-depth case research shedding light on how different standard costing practices can aid or hinder the progression implementations of lean. Further, except Lind (2001) and Tillema and van der Steen (2015), we have little evidence of how management accountants can assist firms reaching lean objectives. For example, are some of their responsibilities handed over to production personnel, as suggested by Cooper (1996), or does an implementation of lean manufacturing create the necessity for management accountants to interact extensively with operations? Future research

might shed light on the roles of management accountants in such a manufacturing regime.

Appendix 1: Questionnaire items

lean Manufacturing

Please indicate below the extent to which your facility has implemented the following

1: Not at all, 2: Little, 3: Some, 4: Considerable, 5: Great deal

- MFG 1 Use of standardization
 - MFG 2 Use of production cells
 - MFG 3 A *Kanban* system
 - MFG 4 Use of one piece flow
 - MFG 5 Reduction of lot sizes
 - MFG 6 Use of line balancing and level schedules
 - MFG 7 Reduction of buffer inventories
 - MFG 8 Use of mistake proofing or *pokayoke*
-

lean Thinking

Please indicate below what most closely represents your facility's organizational culture.

1: Strongly Disagree, 2: Disagree, 3: Neutral, 4: Agree, 5: Strongly Agree

- CLTR 1 All employees are involved in problem solving
 - CLTR 2 Our whole facility is trained in lean principles
 - CLTR 3 Every area of our facility works on continuous improvement
 - CLTR 4 Management is focused on eliminating waste everywhere
 - CLTR 5 lean thinking has permeated all of our operations
-

lean Visual Controls

For the following items, please mark the most appropriate response related to your facility's management accounting system.

1: Strongly Disagree, 2: Disagree, 3: Neutral, 4: Agree, 5: Strongly Agree

- MAS 1 Standard operating procedures are visible on shop floor
- MAS 2 Visual boards are used to share information
- MAS 3 Information on quality performance is reviewed often
- MAS 4 Charts showing defect rates are posted on the shop floor

MAS 5 We have created a visual mode of organization

MAS 6 Information on productivity is updated frequently on the shop floor

MAS 7 Quality data is displayed at work stations

Operational Performance

Please indicate to what extent lean initiatives have affected the following:

1: Not at all, 2: Little, 3: Some, 4: Considerable, 5: Great deal

LIMP

1 Inventory-related resources have been freed up

LIMP

2 Capacity is managed more effectively

LIMP

3 Cycle/production time is improved

LIMP

4 Quality is improved

LIMP

5 Overall communication is improved

Financial Performance

LIMP

6 Costs are reduced

LIMP

7 Profitability is improved

Value Stream Costing

Please indicate the extent to which your facility uses each of the following measurement systems?

1: Not at all, 2: Little, 3: Some, 4: Considerable, 5: Great deal

Value stream costing

Measures of direct labor and materials efficiency

Please indicate the extent to which your facility uses each of the following measurement systems?

1: Not at all, 2: Little, 3: Some, 4: Considerable, 5: Great deal

Performance measures related to labor/material efficiency

lean manufacturing years

Please indicate the following?

lean manufacturing Years

11.7 References

- Adler, P.S., and Borys, B. 1996. Two types of bureaucracy: Enabling or coercive. *Administrative Science Quarterly* 41: 61–89.
- Akaike, H. 1987. Factor analysis and AIC. *Psychometrika* 52: 317–332.
- Banker, R. D., Potter, G., and Schroeder, R. G. 1993. Reporting performance measures to workers: An empirical study, *Journal of Management Accounting Research* 5: 33–55.
- Banker, R. D., Indranil, R. B., and Chen, T. Y. 2008. The role of manufacturing practices in mediating the impact of activity-based costing on plant performance. *Accounting, Organizations & Society* 33: 1–19.
- Bentler, P. M. 1990. Comparative fit indexes in structural models. *Psychological Bulletin* 107: 238–246.
- Bentler, P. M. 1995. *EQS Structural Equations Program Manual*. Encino, CA: Multivariate Software.
- Bentler, P. M., and Bonett, D. G. 1980. Significant tests and goodness of fit in the analysis of covariance structures. *Psychological Bulletin* 88: 588–606.
- Bollen, K. A. 1989. *Structural Equation with Latent Variables*. New York: Wiley.
- Bortolotti, T., Danese, P., Flynn, B. B., and Romano, P. 2015. Leveraging fitness and lean bundles to build cumulative performance sand cone model. *International Journal of Production Economics* 162: 227–241.
- Brosnahan, J. 2008. Unleash the power of lean accounting. *Journal of Accountancy* July: 60–66.
- Browne, M. W., and Cudeck, R. 1993. Alternative ways of assessing model fit. In

Testing Structural Equation Models, edited by Bollen, K. A. and Long, J. S., 136–162. Sage, Newbury Park, CA.

- Byrne, B. M. 2010. *Structural Equation Modeling with AMOS – Basic Concepts, Applications, and Programming* (2nd ed.), Routledge, Taylor & Francis Group. New York.
- Cagwin, D., and Bouwman, M. J. 2002. The association between activity-based costing and improvement in financial performance. *Management Accounting Research* 13: 1–39.
- Callen, J. L., Fader, C., and Krinsky, I. 2000. Just-in-time: A cross-sectional plant analysis. *International Journal of Production Economics* 63: 277–301.
- Callen, J. L., Morel, M., and Fader, C. 2005. Productivity measurement and the relationship between plant performance and JIT intensity. *Contemporary Accounting Research* 22 (2): 271–309.
- Cohen, W. M., and Levinthal, D. A. 1990. Absorptive capacity: A new perspective on learning and innovation. *Administrative Science Quarterly* 35: 128–152.
- Cooper, R. 1996. Look out, management accountants part 2. *Management Accounting* 77 (12): 35–41.
- Cunningham, J. E., and Fiume, O. J. 2003. *Real Numbers: Management Accounting in a Lean Organization*. Durham, NC: Managing Time Press.
- Datar, S., Kekre, S., Mukhopadhyay, T., and Svaan, E. 1991. Overloaded overheads; Activity-based cost analysis of material handling in cell manufacturing. *Journal of Operations Management* 10 (1): 119–137.
- Deng, X., Doll, W. J., Hendrickson, A. R., and Scazzero, J. A. 2005. A multi-group analysis of structural invariance: An illustration using the technology

- acceptance model. *Information & Management* 42 (5): 745–759.
- Dierickx, I., and Cool, K. 1989. Asset stock accumulation and sustainability of competitive advantage. *Management Science* 35 (12): 1504–1511.
- Drury, C. 1992. *Standard Costing*. Academic Press Limited.
- Eisenhardt, K. M., and Martin, J. A. 2000. Dynamic capabilities: What are they? *Strategic Management Journal* 21: 1105–1121.
- Emiliani, M. L., Stec, D., and Grasso, L. 2003. *Better Thinking, Better Results*. The Center for Lean Business Management, LLC.
- Eustler, J., and Lang, B. 2015. Rating scales in accounting research: The impact of scale points and labels. *Behavioral Research in Accounting* 27 (2): 35–51.
- Flynn, B. B., Schroeder, R. G., and Sakakibara, S. 1994. A framework for quality management research and an associated measurement instrument. *Journal of Operations Management* 11 (4): 339–367.
- Fornell, C., and Larcker, D. F. 1981. Evaluating structural equation models with unobservable variables and measurement error. *Journal of Marketing Research* 43 (February): 39–50.
- Fullerton, R. R., and Mcwatters, C. S. 2002. The role of performance measures and incentive systems in relation to the degree of JIT implementation. *Accounting, Organizations and Society* 27: 711–735
- Fullerton, R. R., and Wempe, W. F. 2009. Lean manufacturing, non-financial performance measures, and financial performance. *International Journal of Production Management* 29 (3): 214–240.
- Fullerton, R.R., Kennedy, F., and Widener, S. K. 2013. Management accounting and control practices in a lean manufacturing environment. *Accounting, Organizations and Society* 38: 50–71.

- Fullerton, R.R., Kennedy, F., and Widener, S. K. 2014. Lean manufacturing and firm performance: The incremental contribution of lean management accounting practices. *Journal of Operations Management* 32: 414–428.
- Furlan, A., Vinelli, A., and Dal Pont, G. 2011. Complementarity and lean manufacturing bundles: An empirical analysis. *International Journal of Operations & Production Management* 31 (8): 835–850.
- Grabner, I., and Moers, F. 2013. Management control as a system or a package? Conceptual and empirical issues. *Accounting, Organizations and Society* 38: 407–419.
- Grasso, L. 2005. Are ABC and RCA accounting systems compatible with lean management. *Management Accounting Quarterly* 7 (1).
- Grasso, L., Tyson, T., Skousen, C., and Fullerton, R. R. 2015. Lean practices: A field study. *Cost Management* January/February: 14–24.
- Guilding, C., Lamminmaki, D., and Drury, C. 1998. Budgeting and standard costing practices in New Zealand and the United Kingdom. *The International Journal of Accounting* 33 (5): 569–588.
- Hansen, A., and Mouritsen, J. (2007). Management accounting and changing operations management. In *Issues in Management Accounting* (third ed.), edited by Hopper, T., Northcott, D., and Scapens, R., 3–26. Prentice Hall.
- Hair, J., Black, W., Babin, B., and Anderson, R. 2014. *Multivariate Data Analysis* (7th ed.). Pearson Education Limited.
- Hartmann, F. G. H., and Moers, F. 1999. Testing contingency hypotheses in budgetary research: An evaluation of the use of moderated regression analysis. *Accounting, Organizations and Society* 24: 291–315.
- Henri, J-F. 2006. Organizational culture and performance measurement systems.

Accounting, Organizations and Society 31: 77–103.

- Hines, P., Holweg, M., and Rich, N. 2004. Learning to evolve: A review of contemporary lean thinking. *International Journal of Operations and Production Management* 24 (10): 994–1011.
- Hofer, C., Eroglu, C., and Hofer, A. R. 2012. The effect of lean production on financial performance: The mediating role of inventory leanness. *International Journal of Production Economics* 138: 242–253.
- Hu, L. T., and Bentler, P. M. 1999. Cutoff criteria for fit indexes in covariance structure analysis: Conventional criteria versus new alternatives. *Structural Equation Modeling: A Multidisciplinary Journal* 6: 1–55.
- Huntzinger, J. R. 2007. *Lean Cost Management: Accounting for Lean by Establishing Flow*. J. Ross Publications.
- Huntzinger, J., and Kennedy, F.A., 2005. Lean accounting: Measuring and managing the value stream. *Cost Management* 19 (5): 31–39.
- Ittner, C. D., Lanen, W. N., and Larcker, D. F. 2002. The association between activity-based costing and manufacturing performance. *Journal of Accounting Research* 40 (3): 711–726.
- Ittner, C. D., Larcker, D. F., and Randall, T. 2003. Performance implications of strategic performance measurement in financial services firms. *Accounting, Organizations and Society* 28: 715–741.
- Jayaram, J., Das, A., and Nicolae, M. 2010. Looking beyond the obvious: Unraveling the Toyota production system. *International Journal of Production Economics* 128: 280–291.
- Johnson, H. T. 1992. *Relevance Regained*. New York: The Free Press.

- Jönsson, S., and Grönlund, A. 1988. Life with a sub-contractor: New technology and management accounting. *Accounting, Organizations and Society* 13 (5): 323–343.
- Kaplan, R. S., and Cooper, R. 1998. *Cost and effect: Using integrated cost systems to drive profitability and performance*. Boston: Harvard Business School Press
- Kennedy, F. A., and Widener, S. K. 2008. A control framework: Insights from evidence on lean accounting. *Management Accounting Research* 19 (4): 301–323.
- Kenny, D. A. 2012. *Multiple latent variable models: Confirmatory factor analysis*. Available at: <http://davidakenny.net/cm/mfactor.htm> (last accessed March 1, 2016).
- Khachanapong, T., Prajogo, D., Sohal, A., S., Cooper, B., K., Yeung, A, C., L., Cheng, T., C., E. 2014. The unique and complementary effects of manufacturing technologies on manufacturing and operational performance. *International Journal of Production Economics* 153: 191–203.
- Kihn, L. A. 2005. Comparing performance measurement approaches in accounting research. *Finnish Journal of Business Economics (LTA)* 2: 143–184.
- Kim, S., Yea, S., and Kim, G. 2002. Shift scheduling for steppers in the semiconductor wafer fabrication process. *IIE Trans* 34 (2): 167–178.
- Kline, R. B. 2011. *Principles and Practice of Structural Equation Modeling* (3rd ed.). New York: The Guildford Press.
- Kristensen, T. B., Israelsen, P. 2013. Management accounting system problems in context of lean: Development of a proposed solution. In *The Routledge Companion to Cost Management*, edited by Mitchell, F., Nørreklit, H., and Jakobsen, M., 32–55. Routledge.

- Kristensen, T. B., and Israelsen, P. 2014. Performance effects of multiple control forms in a lean organization: A quantitative case study in a systems fit approach. *Management Accounting Research* 25 (1): 45–62.
- Kristensen, T. B., and Israelsen, P. 2015. Enabling use of management accounting in lean organizations and effect on lean-goal-congruent behavior. *Working paper*.
- Liker, J. 2004. *The Toyota Way*. McGraw-Hill.
- Lind, J. 2001. Control in world class manufacturing—a longitudinal case study. *Management Accounting Research* 12 (1): 41–74.
- Luft, J., and Shields, M. D. 2007. Mapping management accounting: Graphics and guidelines for theory-consistent empirical research. In *Handbook of Management Accounting Research*, edited by Chapman, C. S., Hopwood, A. G., and Shields, M. D., 27–95.
- Maiga, A., S., and Jacobs, F., A. 2008. Assessing JIT performance: An econometric approach. *Journal of Management Accounting Research* 20 (Special Issue): 47–59.
- Maskell, B., Baggaley, B., and Grasso, L. 2012. *Practical Lean Accounting – A Proven System for Measuring and Managing the Lean Enterprise* (2nd ed.). CRC Press.
- Maskell, B., and Kennedy, F. 2007. Why do we need lean accounting and how does it work? *The Journal of Corporate Accounting & Finance* March/April: 59–73.
- Menard, S. 1995. *Applied Logistic Regression*. Thousand Oaks: Sage University paper series on quantitative applications in social sciences, 7–106.

- Monden, Y., and Lee, J. Y. 1993. How a Japanese auto maker reduces costs. *Management Accounting* August: 22–26.
- Netland, T. H., Schloetzer, J. D., and Ferdows, F. 2015. Implementing corporate lean programs: The effect of management control practices. *Journal of Operations Management* 36: 90–102.
- Nelson, R. R., and Winter, S. E. 1982. *An Evolutionary Theory of Economic Change*. Harvard University Press: Cambridge, MA.
- Ohno, T., and Mito, S. 1988. *Just-in-time: For today and tomorrow*. Productivity Press: Portland, OR.
- Podsakoff, P. M., and Organ, D. W. 1986. Self-reports in organizational research: Problems and prospects. *Journal of Management* Winter 12 (4): 531–544.
- Sackett, P. R., and Lawson, J. R., Jr. 1990. Research strategies and tactics in industrial and organizational psychology. In *Handbook of Industrial and Organizational Psychology* (2nd ed.), edited by M. D. Dunnette and L. M. Hough, 419–489. Palo Alto CA: Consulting Psychologists Press.
- Schermelleh-Engel, K., Moosbrugger, H., and Muller, H. 2003. Evaluating the fit of structural equation models: Tests of significance and descriptive goodness-of-fit measures. *Methods of Psychological Research Online* 8 (2): 23–74.
- Schonberger, R. 1987. *World Class Manufacturing: Implementing JIT and TQC*. New York: The Free Press
- Shah, R., and Ward, P., T. 2003. Lean manufacturing: Context, practice bundles, and performance. *Journal of Operations Management* 12: 129–149.
- Shah, R., and Ward, P. T. 2007. Defining and developing measures of lean production. *Journal of Operations Management* 25: 785–805.

- Sila, I. 2007. Examining the effects of contextual factors on TQM and performance through the lens of organizational theories: An empirical study. *Journal of Operations Management* 25: 83–109.
- Snell, S. A. 1992. Control theory in strategic human resource management: The mediating effect of administrative information. *Academy of Management Journal* 35 (2): 292–327.
- Snell, S. A., and Dean Jr., J. W. 1992. Integrated manufacturing and human resource management: A human capital perspective. *Academy of Management Journal* 35 (3): 467–504.
- Solomon, J. M., and Fullerton, R. R. 2007. *Accounting for World Class Operations*. Fort Wayne, IN: WCM Associates.
- Steiger, J. H., and Lind, J. C. 1980. Statistically based tests for the number of common factors. Paper presented at the annual meeting of the Psychometric Society, Iowa City, IA.
- Sulaiman, M., Ahmad, N. N. N., and Alwi, N. 2005. Is standard costing obsolete? Empirical evidence from Malaysia. *Managerial Auditing Journal* 20 (4): 109–124.
- Tillema, S., and van der Steen, M. 2015. Co-existing concepts of management control: The containment of tensions due to the implementation of lean production. *Management Accounting Research* 27: 67–83.
- Tucker, L. R., and Lewis, C. 1973. A reliability coefficient for maximum likelihood factor analysis. *Psychometrika* 38: 1–10.
- Turney, P. B. B., and Stratton, A. J. 1992. Using ABC to support continuous improvement. *Management Accounting* September 74 (3): 46–50.
- Van der Stede, W. A. 2014. A manipulationist view of causality in cross-sectional survey research. *Accounting, Organizations and Society* 39: 567–574.

- Venkatraman, N., and Ramanujam, V. 1986. Measurement of business performance in strategy research: A comparison of approaches. *Academy of Management Review* 11 (4): 801–814.
- Vermeulen, F. 2009. Slow and steady wins the growth race. Available at: <https://hbr.org/2009/02/slow-and-steady-wins-the-growt.html> (last accessed March 1, 2016).
- Wanous, J. P., Reichers, A. E., and Hudy, M. J. 1997. Overall job satisfaction: How good are single-item measures? *Journal of Applied Psychology* 82 (2): 247–252.
- Womack, J. P., Jones, D. T., and Roos, D. 1991. *The Machine That Changed the World*. HarperCollins Publishers.
- Womack, J. P., and Jones, D. T. 2003. *Lean Thinking: Banish Waste and Create Wealth in Your Corporation*. Simon & Schuster.
- Wood, R., Herscher, M., and Emiliani, M. L. 2015. *Shingijutsu-Kaizen – The Art of Discovery and Learning*. The Center for Lean Business Management, LLC, Wethersfield, Conn., USA.
- Woolson, D., and Husar, M. A. 1998. Transforming a plant to lean in a large, traditional company: Delphi Saginaw Steering Systems. GM. In *Becoming Lean: Inside Stories of U.S. Manufacturers*, edited by J. K. Liker, 120–159. Portland, OR: Productivity Press.
- Zayko, M., and Hancock, W. M. 1998. Implementing lean manufacturing at Gelman Sciences, Inc. In *Becoming Lean: Inside Stories of U.S. Manufacturers*, edited by J. K. Liker, 246–301. Portland, OR: Productivity Press.
- Åhlstrøm, P., and Karlsson, C. 1996. Change towards lean production: The role of the management accounting system. *International Journal of Operations &*

Production Management 16 (11): 42–56.

ISSN (online): 2446-1636
ISBN (online): 978-87-7210-075-3

AALBORG UNIVERSITY PRESS