



AALBORG UNIVERSITY
DENMARK

Aalborg Universitet

Improved Observability for State Estimation in Active Distribution Grid Management

Pokhrel, Basanta Raj

Publication date:
2019

Document Version
Publisher's PDF, also known as Version of record

[Link to publication from Aalborg University](#)

Citation for published version (APA):
Pokhrel, B. R. (2019). *Improved Observability for State Estimation in Active Distribution Grid Management*. Aalborg Universitetsforlag.

General rights

Copyright and moral rights for the publications made accessible in the public portal are retained by the authors and/or other copyright owners and it is a condition of accessing publications that users recognise and abide by the legal requirements associated with these rights.

- Users may download and print one copy of any publication from the public portal for the purpose of private study or research.
- You may not further distribute the material or use it for any profit-making activity or commercial gain
- You may freely distribute the URL identifying the publication in the public portal -

Take down policy

If you believe that this document breaches copyright please contact us at vbn@aub.aau.dk providing details, and we will remove access to the work immediately and investigate your claim.

**IMPROVED OBSERVABILITY FOR
STATE ESTIMATION IN ACTIVE
DISTRIBUTION GRID MANAGEMENT**

**BY
BASANTA RAJ POKHREL**

DISSERTATION SUBMITTED 2019



AALBORG UNIVERSITY
DENMARK

IMPROVED OBSERVABILITY FOR STATE ESTIMATION IN ACTIVE DISTRIBUTION GRID MANAGEMENT

by

Basanta Raj Pokhrel



AALBORG UNIVERSITY
DENMARK

Dissertation submitted

Dissertation submitted: July 2019

PhD supervisor: Professor Birgitte Bak-Jensen,
Aalborg University

PhD Co-supervisor: Associate Professor Jayakrishnan R. Pillai,
Aalborg University

PhD committee: Associate Professor Tamas Kerekes (chairman)
Aalborg University
Professor Fabrizio Pilo
University of Cagliari
Chief Project Manager Søren Damsgaard Mikkelsen
Energinet, Denmark

PhD Series: Faculty of Engineering and Science, Aalborg University

Department: Department of Energy Technology

ISSN (online): 2446-1636
ISBN (online): 978-87-7210-464-5

Published by:
Aalborg University Press
Langagervej 2
DK – 9220 Aalborg Ø
Phone: +45 99407140
aauf@forlag.aau.dk
forlag.aau.dk

© Copyright: Basanta Raj Pokhrel

Printed in Denmark by Rosendahls, 2019

The technical software used to conduct this research is:
PowerFactory, DIgSILENT. Versions: 2016, 2017 SP4
MATLAB R, MathWorks R . Versions: R2016b.

This page intentionally left blank.

ENGLISH SUMMARY

Power system scenario is rapidly changing due to the increasing penetration of renewable based DGs at the distribution grid especially at LV and MV level. At the same time, conventional electricity meters are being replaced by smart meters, which can not only monitor energy consumption but also can record many other operating scenarios at the particular node. Also in transmission grid, big conventional generators are being phased out. However, the responsibility of overall grid balance is still with TSO. Consequences of this emerging scenario can be realized by both DSO and TSO owned grid and in their coordination. In LV grid, the availability of huge data due to smart meters at load points, new entities like BRPs, retailers etc. is a big challenge, which is evolving the issues of data security and handling together with processing of huge data for application in network operation and planning. On the other hand, utilities still operate on reduced observability specifically at MV level due to less number of measuring device in the network. PMUs and RTUs are the probable measuring devices but implementation of these devices at every nodes will be very expensive. However, in emerging scenario, DSOs are expected to handle an active network with flexible load, support local balancing, optimally utilize the distributed generation and set up active interaction with TSOs too.

In this PhD study, four issues from DSO perspective in the emerging scenario in electricity network such as huge data handling, network observability with minimum measurements, active network management and optimized operation, and TSO-DSO interoperability and coordination have been identified. These issues are further investigated, elaborated and solved by using mathematical models, dedicated network setups and case studies. Huge data handling issue is addressed by minimum measurement placement technique embedded with bus prioritization concept, which is then integrated with network observability and distribution state estimation procedure. Accuracy in estimated network parameters is assured by using improved forecasting procedure for pseudo measurement models. Models to evaluate tradeoff between network observability, estimation accuracy and used number of measurements have been proposed that can be useful for DSO to limit the investment in measurement devices. Active network management issue have been addressed by developing the prototype of ADMS model by integrating grid measurement, forecasting and state estimation modules with control algorithm in a close loop. As one of the key functionality of ADMS, loss optimization procedure and operation framework have been developed considering the availability of DSO owned storage facility, high penetration of DG and option of network reconfiguration. Also, proposed integrated algorithm of network observability for state estimation have been tested using real measurement data from selected network points of a Danish distribution LV and MV network. Analysis on observed network status and discussion on state estimation are presented. Finally, requirement of new

coordination framework for TSO and DSO have been assessed. Role of network observability i.e. knowledge of each other's grid asset information in certain extent for the mutual benefit (for all utility operators) is highlighted. Assessment of current practice and need for revision specially on huge data handling, new market set up by involving DSO on market clearing process, use of DSO knowledge on network expansion planning etc. are investigated and way for future cooperation of TSO and DSO is recommended. Architecture for multi energy system for optimized operation is also proposed at the end.

DANSK RESUME

El-systemet ændrer sig hurtigt på grund af den stigende andel af vedvarende decentrale energikilder (DGs) tilsluttet distributionsnettet, især på lav- og mellemspændingsniveau. Samtidig erstattes konventionelle elmålere med intelligente målere, som ikke kun kan overvåge energiforbruget, men også kan måle mange andre driftsscenerier ved den pågældende knude. Også i transmissionsnettet bliver store konventionelle generatorer udfaset. Imidlertid er ansvaret for den samlede netbalance stadig hos den system ansvarlige. Konsekvenserne af dette fremvoksende scenarie kan realiseres af både distributionsselskabernes og de systemansvarliges net og ved deres samkørsel. I lavspændingsnettet er tilgængeligheden af enorme data på grund af intelligente målere ved belastningspunkter, nye enheder som balanceansvarlige el-handlere mv. en stor udfordring, der adresserer spørgsmålene om datasikkerhed og håndtering sammen med behandling af enorme data til anvendelse til nettets drift og planlægning. På den anden side opererer forsyningsselskaberne stadig ved reduceret observerbarhed specifikt på mellemspændingsniveau på grund af mindre antal måleenheder i nettet. PMU'er og RTU'er er mulige måleenheder, men implementering af disse enheder ved hver knude vil være meget dyrt. Men i fremtidens scenarie forventes distributionsselskaberne at håndtere et aktivt net med fleksibel belastning, støttende lokal balancering af nettet, optimalt udnyttelse af de distribuerede energikilder og etablering af aktiv interaktion med transmissionsnettet.

I dette PhD studie er der identificeret fire problemstillinger fra distributionsselskabernes perspektiver i fremtidens elnet, så som stor databehandling, net observerbarhed med minimum antal målinger, aktiv netværksstyring og optimeret drift samt integration og koordinaton mellem transmissions- og distributionssystemerne.. Disse spørgsmål bliver yderligere undersøgt, uddybet og løst ved hjælp af matematiske modeller, dedikerede netmodeller og casestudier. Databehandlingsproblemet behandles ved hjælp af en teknik for minimum antal målerplaceringer indlejret med et busprioriteringskoncept, som derefter integreres med netobserverbarhed og estimering af distributionsstatus. Nøjagtigheden af de estimerede netværksparametre sikres ved at anvende en forbedret prognoseprocedure til at lave gæt for målinger (pseudo-målinger). Modeller til evaluering af afvejning mellem netobserverbarhed, estimeringsnøjagtighed og brugt antal målinger er opsat, hvilke kan være nyttige for distributionsselskaberne for at begrænse investeringen i antal måleenheder. Aktiv styring af nettet er adresseret ved at udvikle en prototype for et Aktiv DistributionsManagement System (ADMS) ved at integrere moduler for netmålinger, prognose og estimering med en styringsalgoritme i en lukket sløjfe. Som en af nøglefunktionaliteten i ADMS er der blevet udviklet tabsoptimeringsprocedurer og et drifts set up baseret på tilgængeligheden af DSO-ejede lageringsfaciliteter, stor andel af vedvarende energikilder samt mulighed for at

om konfigurere nettet. Desuden er den foreslåede integrerede algoritme for netværksobserverbarhed og estimering af driftsstatus blevet testet ved hjælp af virkelige måledata fra udvalgte målepunkter i et dansk lav- og mellemspændingsnet.. Analyse af observeret netstatus og diskussion af state-estimeringen præsenteres. Endelig er krav til en interaktionsramme mellem transmissions og distributionsselskaberne blevet vurderet. Observerbarhed dvs. kendskab til hinandens netaktivitetsoplysninger i et vist omfang til gensidig fordel (for alle brugsoperatører) fremhæves. Vurdering af den nuværende praksis og behovet for revision specielt vedrørende den enorme mængde data og -behandling, nye markeder etableret ved at involvere distributionsselskaberne under markeds clearingprocessen, samt brug af distributionsselskabernes viden om netudvidelsesplanlægning mv. undersøges, og veje for fremtidigt samarbejde mellem transmissions-og distributionsselskaberne anbefales. En arkitektur til optimeret drift i multi-energisystemer foreslås til slut.

ACKNOWLEDGEMENTS

The journey that led to this thesis was rocky and long. Alike everything in life, it is possible only because of the support and help from quite a number of people. Without the emotional support from my family it would never had been possible to walk through this path. First, I would like to deeply thank my wife and son for their unconditional love, support and patience during all the time. You always believe in my capabilities and continuously gave courage to try. A big thanks to my parents, parents in law and each member of my family for their devotion, support and belief on me.

This research was carried out as per the context of DECODE project funded by Energinet.dk, the Danish transmission system operator through ForskEL-PSO funding. I would like to gratefully acknowledge the financial support via DECODE project for the research activities. In addition, I would like to thank and appreciate Doctoral School of Engineering and Science, Aalborg University for the financial support to carry out study abroad in connection with the PhD study. Without abovementioned financial support, this research work would not have been possible. This thesis is related to five out of eight work packages of DECODE. Technical contributions from each project participants including AAU-ET, Energi, ABB A/S, Syd Energi, and Kenergy is appreciated. Special thanks goes to Allan Jensen, Jakob Kledal, Jacob Andreasen, Kenn Henrik Bournonville Frederiksen and Thomas Helth for providing technical data for the research as well as for the fruitful discussions and input during quarterly project meetings.

Honestly, Starting PhD in Denmark was perhaps one of the best decision I could ever have taken. This research study has been carried out under the supervision of Prof. Birgitte Bak-Jensen and Associate Prof. Jayakrishnan R. Pillai. I would like to thank with deepest gratitude to my both supervisors for providing the opportunity to pursue PhD within their group and always supporting me with guidance and full of encouragement. I would also like to thank them for introducing me in the smart grid research area. Author would like to express special thanks to his colleague Karthikeyan Nainar for wonderful collaboration throughout the DECODE tenure for project activities and for all the discussions, laughter, and refreshment talks. Moreover, the assistance of author's colleague Dr. Yam P. Siwakoti and Dr. Pavani Ponnaganti is also appreciated. I have always had the nicest time and support during my research work in the department. So, I would like to thank everybody in the Department of Energy Technology, Aalborg University. I would also like to thank all

the PhD course instructors for helping me to develop solid background for the research work.

Lastly, I would like to appreciate and thank Prof. C. Y. Chung for hosting the study abroad at SMART Lab, Department of Electrical and Computer Engineering, University of Saskatchewan, Canada. Likewise, the assistance of Dr. S. M. Mazhari during the study abroad is also acknowledged. I am also thankful to all the members of the ECE department at USASK.

Apologies if I had missed someone but each of you who had supported me to come up with this thesis, definitely deserve honest appreciation. I really value your help and support, thank you so much.

Basanta Raj Pokhrel

July 22, 2019

Aalborg Øst, Denmark

TABLE OF CONTENTS

Chapter 1. Introduction.....	1
1.1. Introduction of the project.....	1
1.2. Introduction of the danish Electricity Grid.....	2
1.2.1. Transmission System Operator	2
1.3. Distribution System Operator	3
1.3.1. Key actors in the electricity system in Denmark.....	3
1.4. Background study	4
1.5. Problem formulation	5
1.6. Assumptions.....	7
1.7. Architecture and framework for improved network observability	8
1.8. Thesis Outline and Publications.....	9
Chapter 2. State of Art	13
2.1. Application of Network monitoring and DSE.....	13
2.2. Network measurements and observability	14
2.3. State estimation	15
2.3.1. Availability of data for DSE.....	16
2.3.2. Measurements applicable to DSE.....	16
2.3.3. Methods of DSE.....	17
2.4. Forecasting	18
2.5. Advance distribution management system.....	20
2.6. Utility interface (TSO-DSO-Market) in new scenario	20
2.7. Summary	21
Chapter 3. Improving distribution grid observability for DSE	23
3.1. Observability and meter placement.....	23
3.2. Distribution state estimation (DSE)	25
3.3. Pseudo measurements modelling - Forecasting	27
3.4. Integrated analysis of improved observability for DSE and estimation accuracy trade off.....	29
3.5. Summary	33

Chapter 4. Advanced distribution grid management system	35
4.1. Advanced distribution management system.....	35
4.2. Loss observation and minimization.....	40
4.3. Interoperability and standards for ADMS	43
4.4. Summary	44
Chapter 5. Measurement setup in the real network and analysis.....	47
5.1. LV network set up	47
5.2. MV network set up.....	51
5.3. Conclusions and Lesson learned	56
Chapter 6. role of observability in enhanced cooperation of energy utilities.....	57
6.1. TSO-DSO interface in a smart grid environment.....	57
6.1.1. Specific grid operation challenges	58
6.1.2. Current practice and new dimension of TSO-DSO interface	59
6.2. Integrated energy system Architecture.....	61
6.3. Summary.....	62
Chapter 7. Conclusions.....	63
7.1. Summary	63
7.2. Contributions.....	63
7.3. Recommendations for the future works	64
References.....	67
Publications	75

LIST OF FIGURES

Figure 1-1 Linkage of improved observability research with DECODE project	1
Figure 1-2 Electricity transmission system in Denmark, 2020 [3].....	2
Figure 1-3 Emerging scenario of Distributed generations in Denmark [9].....	4
Figure 1-4 Share of renewable energy in EU [11],[12].....	5
Figure 1-5 Architectural framework with network observability clusters[1].....	9
Figure 2-1 Advanced automation possibilities in distribution system using improved network observability, SE and its application in active distribution management system	14
Figure 3-1 State estimation set up in power distribution network.....	25
Figure 3-2 Comparison of Actual and forecasted load [72].....	28
Figure 3-3 Improved observability for SE and estimation accuracy trade off evaluation	29
Figure 3-4 Customized Lind area network showing observable islands when bus prioritization is not considered.....	31
Figure 3-5 Comparison of estimated states [71]	32
Figure 4-1 Conceptual block diagram for ADMS.....	36
Figure 4-2 Modified LV network from Lind area.....	37
Figure 4-3 Actual and forecasted load (Commercial) for 24 hours.....	39
Figure 4-4 Estimated voltages in all eight buses.....	39
Figure 4-5 Error plot in SE when operated in close loop with control algorithm	40
Figure 4-6 Generic model of distribution grid with DG and BESS at arbitrary location [75].....	41
Figure 4-7 Plot of sensitivity index for storage allocation	43
Figure 4-8 Optimized power loss in different cases.....	43
Figure 4-9 Structure for smart grid interoperability.....	44
Figure 5-1 Geographical map of LV distribution grid [78].....	48
Figure 5-2 Single line diagram of the distribution grid.....	49
Figure 5-3 Total apparent power profile at CB1 during week 21	50
Figure 5-4 Voltage profile at CB1 during week 21	50
Figure 5-5 Plot of estimation error.....	51
Figure 5-6 Geographical location of VKH substation (Transformer KT21: 60/10kV)[78].....	52
Figure 5-7 Snapshot of network showing meters at VKH substation [78].....	52
Figure 5-8 Basic layout of RTU520 and possibility of data extraction[81]	53
Figure 5-9 Sample of measurement loss: observation on bus 10	53
Figure 5-10 Single line diagram of MV network with measurement setup	54
Figure 5-11 Voltage profile observed at three measurement locations on 28 June 2019	55
Figure 5-12 Voltage profile observed on June 1	55
Figure 5-13 Impact of data loss on voltage estimation on June 1	56
Figure 6-1 Stakeholders interaction in (i) traditional and (ii) emerging scenario	58

Figure 6-2 Illustration of observability area in a Danish scenario	60
Figure 6-3 Integrated energy system architecture	61

LIST OF TABLES

TABLE 1-1 Details of proposed use cases [1]	8
TABLE 1-2 Linking publications with the thesis chapters	12
TABLE 2-1 Other factors that can influence the forecasting	19
TABLE 2-2 Correlation index and its meaning	20
TABLE 4-1 Network data - Load details	38
TABLE 4-2 Network data – Line details	38

ACRONYMS

AAU	Aalborg University
ADMS	Advanced Distribution Management System
ADN	Active Distribution Networks
AMI	Advanced Metering Infrastructure
ANN	Artificial Neural Network
APE	Absolute Percentage Error
BESS	Battery Energy Storage System
BRP	Balance Responsible Party
CIGRE	International Council on Large Electric Systems
CPP	Centralized Power Plants
DEP	Data Exchange Platform
DER	Distributed Energy Resources
DG	Distributes Generators
DN	Distribution Network
DSE	Distribution State Estimation
DSO	Distribution System Operators
DSR	Demand Side Response
EU	European Union
EV	Electric Vehicle
GIS	Geographic Information System
IED	Intelligent Electronic Device
IEMS	Integrated Energy Management System
MAPE	Mean Absolute Percentage Error
NN	Neural Network
PEV	Plugin Electric Vehicle
PMU	Phasor Measurement Unit
RE	Renewable Energy
RTU	Remote Terminal Unit
SCADA	System Control and Data Acquisition
SE	State Estimation
TSO	Transmission System Operators
WLS	Weighted Least Square

CHAPTER 1. INTRODUCTION

This chapter is framed to describe the project idea, research objective and overview of Denmark's power grid. Based on the background the problem formulation for network observability is presented, which is supported by an architectural framework setup that will be used in the rest of the research. The chapter summarizes the research concept and the framework which is presented in the paper [1].

1.1. INTRODUCTION OF THE PROJECT

This research work is a part of the project “Determination of automation demands for improved controllability and observability of distribution networks (DECODE)” that deals with enhanced observability and control of active distribution grids. It covers contributions to work packages (WP) 1, 3, 5, 6 and 7 of the DECODE project as shown in Figure 1-1.

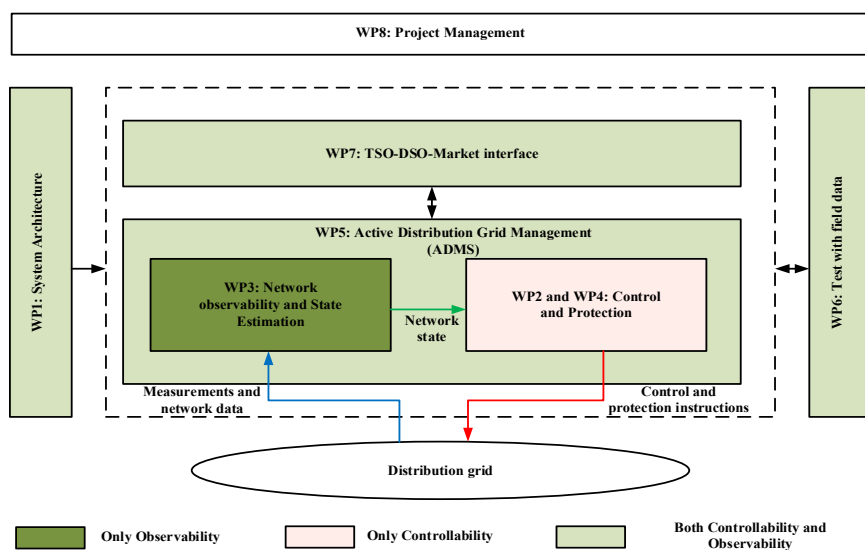

Figure 1-1 Linkage of improved observability research with DECODE project

DECODE is funded by Energinet.dk, the Danish transmission system operator through ForskEL-PSO funding. The overall objective of the DECODE project is to find methodological guidelines which will help the DSO to smarten the automation systems and processes in the distribution management system. That will allow the integration of more renewables into the grid with minimum investment on infrastructure and also facilitate smarter demand response activities too. Specific

objective of this PhD research which are in line with some of the DECODE objectives are described in detail in section 1.5 of this chapter.

1.2. INTRODUCTION OF THE DANISH ELECTRICITY GRID

1.2.1. TRANSMISSION SYSTEM OPERATOR

In Denmark, the transmission of electricity and gas is owned by an independent public company Energinet.dk owned by the government of Denmark [2]. The objectives of Energinet.dk as a transmission system operator are to operate and expand the electricity and gas transmission network efficiently and provide open and equal access for all users in the grid. The TSO operates the high voltage transmission network above 60 kV and ensures power balancing in Denmark taking also export/import power with other countries into account. The TSO does not own production units and relies on ancillary services from power suppliers to balance the generation and consumption in the transmission grid. The transmission system in Denmark is divided in two different grids Western (DK1) and Eastern (DK2) as shown in Figure 1-2.

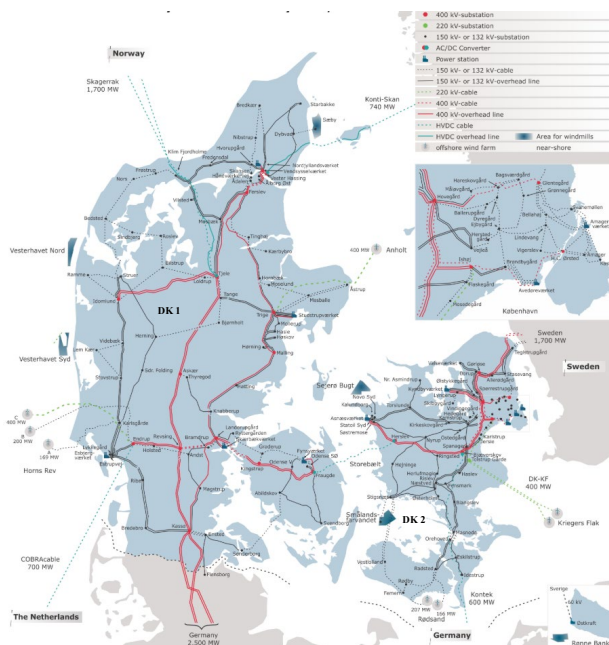

Figure 1-2 Electricity transmission system in Denmark, 2020 [3]

Both are owned by Energinet.dk. These two grids are connected by a 600 MW HVDC link Great Belt [4]. The Danish transmission system has a cross border links with Norway, Germany and Sweden; via HVAC / HVDC lines in ranges from 132 kV to

400 kV. Cross border link with Denmark and The Netherlands via COBRACable is under construction and will be commissioned in 2019 [5].

1.3. DISTRIBUTION SYSTEM OPERATOR

The Distribution System Operator operates the distribution network (normally voltage level 60kV to 0.4 kV) and logs the generation and consumption by metering individual producers and consumers. DSOs are the distribution companies, which are responsible to ensure the delivery of power to the customer end. Each DSO owns the infrastructure in its own area and is responsible for its operation so they have monopoly in their individual areas. Before 2012 there were more than 100 DSOs in Denmark but due to merging of some DSOs it is reduced to 75 as of today [6]. Dong, SEAS-NVE, Syd Energi, NRGi and Energi (HEF and ENERGI MIDT) are some of the major DSOs [7]. The DSO is responsible for providing adequate grid capacity to bring the demanded electric power to the final customers on the lower voltage levels maintaining a certain voltage quality. Besides a stable local voltage control, the main challenge for the DSO is to prevent bottlenecks in the distribution grid. Such bottlenecks may be caused by the uncertain changing demand from end consumers as well as integration of more dispersed generations. Traditionally, congestion problems are overcome only by physically expanding the grid capacity and feeder reinforcements.

1.3.1. KEY ACTORS IN THE ELECTRICITY SYSTEM IN DENMARK

Apart from TSO and DSO there are some other key actors in the electricity system in Denmark which are: power producer, Balance Responsible Party (BRP), Aggregator, Customers etc.

A power producer is the owner of central or distributed generation who produces electric power and sell it to the electricity market. Evolution of distributed generation in Denmark is given in Figure 1-3, which shows the trend of displacement of conventional central plants by DGs. BRP is a commercial actor or market participant (not a utility) responsible for its imbalance in the electricity market. Hence, BRP is responsible for submitting bids that reflects the expected consumption, generation or trade plans on the electricity spot market one day ahead of delivery. The TSO is responsible for monitoring compliance with the submitted consumption or generation plans. Deviations result in punitive charges placed on the BRP. In Danish electricity market, there are 47 BRPs as of today [8]. Aggregator is a new entity in the electricity market who acts as mediators or brokers between customers and the system operators and balancing responsible parties. Aggregator aggregates the small generators and bid in electricity market on behalf of each small producer.

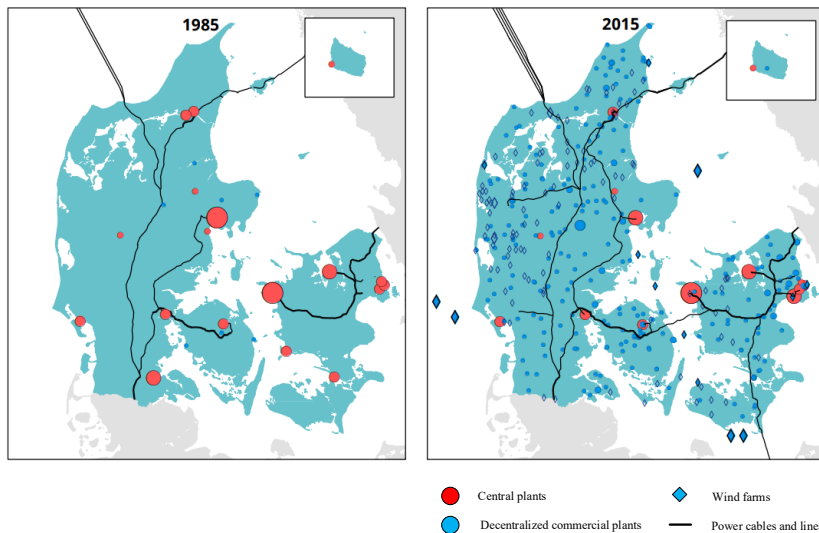

Figure 1-3 Emerging scenario of Distributed generations in Denmark [9]

Customers are the end users of electricity and hence they are the last link of the supply chain in a traditional power system. Electricity consumer covers the wide range from domestic users to industries. Both industrial and residential types of customers require high quality, reliable and affordable power 24x7 for their well-being. In recent years, customers are encouraged by governments and regulatory authorities to install and operate renewable energy sources such as solar PV and wind turbines to support green energy initiatives. Since they produce and consume power simultaneously, a new term called “prosumer” is used to distinguish from customers who always consume power. Prosumers are the distributed generator owner who consume power as well as sell it to the grid.

1.4. BACKGROUND STUDY

Due to increased awareness in clean energy share of renewable energy in overall electricity system is increasing globally. European Union is on its way to meet its green energy target i.e. 20% share of renewable energy in energy mix by 2020 and accelerate it to 100% by 2050 [10]. In line with this EU initiative, all the member states have setup their respective milestones. In this regard, Denmark’s milestone is to meet 50% of electricity demand from wind power plants by 2020 and meet the 100% energy demand from renewable energy by 2050. Potential of individual countries in Europe to scale up the renewable energy is highlighted by the International Renewable Energy Agency (IRENA) in its roadmap 2030 as shown in Figure 1-4 [11], [12]. If right framework to allow increased penetration of RE in the system is put in place, EU can double the share of RE in its total energy mix i.e. 17% in 2015 to 34% in 2030 [11].

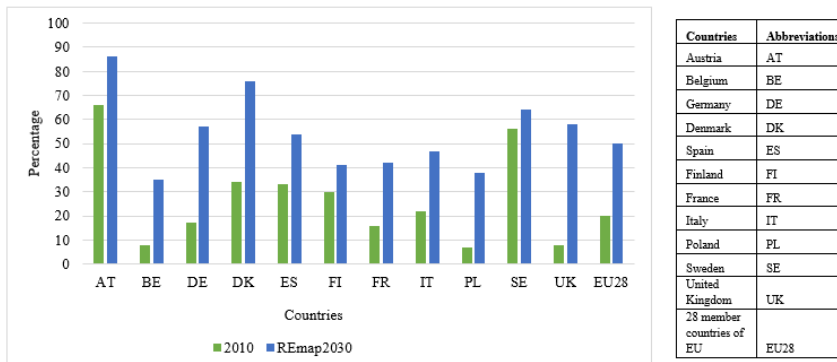

Figure 1-4 Share of renewable energy in EU [11],[12]

Fundamental nature of power system is changing due to this movement towards a sustainable energy roadmap, where role of RE producers and customers is kept in center [13]. Traditional distribution networks are mostly passive with non-flexible demand, where DGs are connected in fit and forget approach. However, in emerging scenario, DSOs are expected to handle an active network with flexible load, support local balancing, optimally utilize the distributed generation and set up active interaction with TSOs too.

For the DSOs, the transformation of their passive grids into intelligent active electricity networks needs to be cost-effective. The implementation of the advanced distribution grid automation and network management should rely on technologies that should use existing infrastructures to a larger extent and then only install minimum possible number of additional measuring devices in their domain maintaining the quality and reliability of the electricity supply service and at the same time have a good observability of the network state.

1.5. PROBLEM FORMULATION

Active network management and advanced grid automation is a prerequisite for an effective utilization of constantly increasing RE generation technologies (E.g.: wind, solar) and to realise synergy and support from flexible demand. The distribution grids are characterised by a huge number of nodes and feeders. Only very limited knowledge is presently available for the DSO about the whole state of the network and its ability to handle the growing complex interactions between the volatile generation and the loads. Due to economic reason very limited number of measuring device are available in MV network. However, in near future almost every load point in the LV network will be equipped with smart meters due to the availability of modern metering infrastructure [14]. Apart from the measuring scenario, DGs in distribution networks are replacing conventional generators in the transmission network and at the same time customer behaviour is also changing, they want to

participate in market either as a prosumer or involve in demand response activities (smart consumer/prosumers). Major challenges due to this emerging scenario in electricity system can be grouped as:

- Reduced observability of the MV grid due to the availability of limited measurement data from MV network and efficient handling of huge data available from LV grid due to the presence of advance technology and new actors (E.g.: smart meter, retailers, BRP, aggregators etc.).
- Technical challenge due to existing reduced network observability for the operation of active distribution grid, where the penetration of increasing level of unpredictable generation (E.g.: wind and solar) and smart consumers/prosumers are increasing.
- Interoperability and coordination challenge for TSO-DSO-market due to the presence of new actors and their willingness towards active participation in electricity market.

These challenges are investigated thoroughly and simple as well as efficient solutions are presented. To address these challenges main goal of the project is summarized as the two research questions listed below:

1. How to develop a new network observability model that can observe the network and be able to estimate the network state accurately utilizing minimum key real measurements?
2. How to address the interoperability and coordination challenge for utilities and market in the emerging scenario ?

These research questions are tackled as per the project objectives given below:

- Develop high-level system architecture for the distribution system measurement and observability that can be embedded to control system. It is based on the use cases defined from the needs of system operators for active distribution grid control and management from DSO perspective.
- Development of improved observability module embedded with DSE algorithms and measurement placement in distribution grids. Verify its performance assessment for improved distribution grid observability. Developed novel and robust network observability and state estimation procedures and models for network operation application that will accurately measure and are able to affect the system states of grid assets in electricity distribution networks.
- Develop improved short term forecasting and modelling of load/generation profiles for pseudo measurements that is required for state estimation. This forecasting module considers the parameters that are highly correlated and have impact on the forecasted profile for the particular locations to ensure the forecasting accuracy.

- Investigate the scope and recommend the procedure for appropriate interfaces between DSO and TSO with market for system security and reliability in the emerging scenario.

The solutions to these questions can be applied to produce an optimal distribution grid management system for DSO planning and control operations that ensures the best utilisation of assets and integration of renewable based distributed energy resources in a sustainable manner, and at the same time keeping the automatization and thereby the costs to a minimum.

1.6. ASSUMPTIONS

In order to minimize the complexity of the research problem, it has to be simplified to a certain extent. Some of the important assumptions and simplifications considered in the study are described below:

- **Network model and data:** Verification of proposed model and set up is done in a CIGRE benchmark network model [15] and on a real 52 bus network from Lind Area, Denmark. This 52 bus real network is modified to a 25 and a 30 bus network for different case studies and lumped parameters are used. All the network data are based on the information given by the Danish DSO Energi (by person and via GIS map). Weather data from AAU solar lab Aalborg have been used for the analysis. Other influencing factors for forecasting (e.g.: social events, holidays etc.) are limited to Denmark. In this work network model is considered to be fixed and known exactly. But in reality, not only the load growth and network expansion but also environmental factors can change the network parameters [16], [17]. These impacts are not considered in this work.
- **Technical Simplifications:** In the MV analysis, aggregated load and generation at the distribution transformer locations are considered. The study is limited to a radial feeder setup and LV network from same Lind area. Limitations on the communication infrastructure (efficiency of data collection, storage size, transmission capacity etc.) for measurement collection are not considered in this study. Asymmetrical network structure and unbalanced loading conditions are also not considered. Control and protection issues have been taken care by another research in DECODE project and is therefore not included in this thesis.

Although the proposed model and set up is simplified using above assumptions. These assumptions should not be considered as technical limitations and the proposed modules are extendable and applicable to any active distribution network for dynamic cases studies too.

1.7. ARCHITECTURE AND FRAMEWORK FOR IMPROVED NETWORK OBSERVABILITY

In order to achieve the project goals, an architectural set up for enhanced network observability is proposed. Initially use cases are defined based on the review of the DSO practices, challenges and requirements (Surveyed from DSOs E.g.: Eniig, Syd Energi etc.) for active distribution networks. Then a relevant system architecture is proposed for the enhanced observability that can be used for improved system control and protection. Use case formulated for any project work is the structure or setup that will highlight or explain the purpose served by the final solution or product of that project at the end. These use case can be defined from different standpoint for example from TSO, DSO, Consumer or Prosumer perspective. In this work, it is typically from DSO perspective. Use cases concerning network observability and state estimation have been identified and are listed below in TABLE 1-1.

TABLE 1-1 Details of proposed use cases [1]

No.	Use cases	Purpose	Main Benefiter
1	Forecasted load/generation profile	DSO – to formulate dispatching plan DSO – to formulate operation and maintenance calendar, voltage control and network reconfiguration Prosumers – to bid in electricity market via electricity retailer	DSO, Prosumer
2	Supervision of the distribution network close to real time	DSO – to know the state of the network via DSE and plan effectively in short term situation DSO – input for implementing hierarchical control	DSO
3	Loss optimization in ADN	DSO – economized operation	DSO
4	Frame work for advance distribution grid management system (ADMS)	DSO – check for interoperability DSO – Application of DSE and its performance check.	DSO, TSO
5	TSO-DSO-market interaction in emerging scenario	Auxiliary service Bottleneck management	DSO, TSO, Prosumer

The system architecture set up specifically for network observability and state estimation which is based on the use cases described in TABLE 1-1 is given in Figure 1-5. The system is divided in two layers which are physical power system layer and network observability layer. It is interconnected with control mechanisms and

- **Chapter 2:** Overall state of art is discussed in this chapter to show the link of presented work with current trend and scenario. Specifically brief review on Network observability, State estimation, Forecasting, Loss minimization and Utility interface in emerging scenario is covered.
- **Chapter 3:** This is the important chapter where tackling of the observability problem and proposed solution is explained. It covers the observability analysis, meter placement, forecasting, distribution state estimation and integrated analysis with description of models, results and analysis.
- **Chapter 4:** Concept of advanced distribution management system is discussed here where integration of the observability module with control blocks are introduced. It also covers the loss observation and optimization in active distribution network.
- **Chapter 5:** Validation of proposed observability modules with real measurement data from the field set up is described here. Details of measurement setup in the field and results and analysis for both LV and MV network cases are discussed in this chapter.
- **Chapter 6:** Analytical analysis for the TSO-DSO-Market interface and coordination in emerging scenario is presented in this chapter. Description about current scenario, necessities of improved observability and state estimation and its impact on the operation is highlighted in this part. Concept of integrated energy system and its framework is also described in this section of the thesis.
- **Chapter 7:** This is the final chapter, which concludes the thesis with lesson learned from the research project. Major contributions are highlighted and possibilities for the future extensions are recommended.

The outcome of the PhD research work performed during the study period has resulted in the following manuscripts. This thesis report is based on the work published in these papers and contains the summary of it. Following list includes accepted, under review or to be submitted manuscripts in conferences and journal papers as well as a book chapter.

Conference Papers:

- C1: B. R. Pokhrel, N. Karthikeyan, B. Bak-Jensen, and J. R. Pillai, “Intelligent architecture for enhanced observability for active distribution system,” in IEEE PES Innovative Smart Grid Technologies Conference Europe (ISGT-Europe), 2017, pp. 1–6.
- C2: B. R. Pokhrel, N. Karthikeyan, B. Bak-Jensen, and J. R. Pillai “Loss optimization in distribution networks with distributed generation,” Proceedings of 52nd International Universities Power Engineering Conference (UPEC). IEEE Press, 2017.

- C3: B. R. Pokhrel, B. Bak-Jensen, J. R. Pillai, S. Mahdi Mazhari and C. Y. Chung, “An Intelligent Approach to Observability of Distribution Networks,” in Proceedings of IEEE PES General Meeting, USA, 2018.
- C4: B. R. Pokhrel et.al, “Effect of Smart Meter Measurements Data On Distribution State Estimation,” in Proceedings of 19th IEEE International Conference on Industrial Technology (ICIT), 2018, pp. 1207–1212.
- C5: N. Karthikeyan, B. R. Pokhrel, J. R. Pillai, B. Bak-Jensen, A. Jensen, T. Helth, J. Andreasen, and K. H. B. Frederiksen, “Coordinated Control with Improved Observability for Network Congestion Management in Medium-Voltage Distribution Grid,” in Proceedings of CIGRE Session, 2018.
- C6: B. R. Pokhrel, N. Karthikeyan, B. Bak-Jensen, J. R. Pillai, A. Jensen, J. Andreasen, T. Helth, and K. H. B. Frederiksen, “Improved TSO - DSO Interoperability and their cooperation in smart grid,” in Proceedings of CIGRE Symposium Aalborg, 2019

Journal Papers:

- J1: B. R. Pokhrel, B. Bak-Jensen, J. R. Pillai, “Integrated Approach for Network Observability and State Estimation in Active Distribution Grid,” *Energies* 2019, Volume 12, Issue 12 (ISSN 1996-1073; CODEN: ENERGA).
- J2: B. R. Pokhrel, B. Bak-Jensen, J. R. Pillai, “Testing and implementation of network observability and state estimation in real active distribution system,” *IEEE Transactions in smart grid*, - working paper

Book Chapter:

- B1: B. R. Pokhrel, N. Karthikeyan, R. Sinha, B. Bak-Jensen, and J. R. Pillai, “Architecture of integrated energy systems,” a book chapter in *Reliable and Sustainable Electric Power and Energy Systems Management*, Springer 2019 – under review

Major technical description of this thesis is from above mentioned papers. Hence, relation of each chapter with the publications is prepared and shown in TABLE 1-2.

TABLE 1-2 Linking publications with the thesis chapters

Chapter No.:	1	2	3	4	5	6	7
Publications:	C1	-	C3, C4, C5, J1	C2, J1	J2	C6, B1	-

In addition to the above-mentioned papers, one technical report have been prepared (WP3) and contribution on four technical reports (WP1, WP5, WP6, WP7) were made that were submitted to the DECODE project consortium during the project tenure. A part from the aforementioned reporting, contributions to the following publications have been made during the PhD period but are not considered in this thesis report.

- N. Karthikeyan, B. R. Pokhrel, J. R. Pillai and B. Bak-Jensen, “Multi-level Control Framework for Enhanced Flexibility of Active Distribution Network,” in IEEE PES Innovative Smart Grid Technologies Conference (ISGT), USA, 2017, pp. 1–6.
- N. Karthikeyan, B. R. Pokhrel, J. R. Pillai, B. Bak-Jensen and Frederiksen Kenn H. B “Demand Response in Low Voltage Distribution Networks with High PV Penetration,” Proceedings of 52nd International Universities Power Engineering Conference (UPEC). IEEE Press, 2017.
- N. Karthikeyan, B. R. Pokhrel, J. R. Pillai and B. Bak-Jensen, “Coordinated Voltage Control of Distributed PV Inverters for Voltage Regulation in Low Voltage Distribution Networks,” in IEEE PES Innovative Smart Grid Technologies Conference Europe (ISGT-Europe), 2017, pp. 1–6.
- N. Karthikeyan, B. R. Pokhrel, J. R. Pillai and B. Bak-Jensen, “Utilization of Battery Storage for Flexible Power Management in Active Distribution Networks,” in Proceedings of IEEE PES General Meeting, USA, 2018.
- N. Karthikeyan, B. R. Pokhrel, B. Bak-Jensen , J. R. Pillai, A. Jensen, J. Andreasen, K. H. B. Frederiksen and T. Helth, “Advanced TSO-DSO Interface for Provision of Ancillary Services by DER in Distribution Networks,” in Proceedings of CIGRE Symposium Aalborg, 2019

CHAPTER 2. STATE OF ART

This chapter presents the overall framework for the application of improved observability for DSE in active distribution management and summarizes the literatures that are relevant to this research work. This section of the thesis covers the discussion on different technical strategies followed to solve the problems for network observability in the electricity network specially focusing on distribution systems. It also covers the concepts of network monitoring, state estimation and load/generation forecasting, which are the essential elements of active distribution grid management system. Review on TSO-DSO-Market interaction in active system is also covered.

2.1. APPLICATION OF NETWORK MONITORING AND DSE

Knowledge of estimated states from the observable network facilitates the real time monitoring of the grid assets because DSO can take the instant decision based on the information of real time network parameters. Due to the application of DSE, information of initial state of the network will be available at any instant to DSO, which can be used for many ADMS applications. Some examples are: congestion management, network reconfiguration, loss minimization, Volt/Var control, optimum utilization of available resources, day-ahead planning, active control of distribution grid, ensure system security, non-technical loss detection, calculation of locational marginal price etc. [18], [19].

Challenges in network observability and monitoring still persists and demands for accurate, adaptive, efficient and yet simple procedures that can be applicable to active distribution systems. Network models used in DSE are never perfect. Uncertainties occurring from topology, network parameters (environmental impact, network reduction etc.), operating conditions, measurements and data correlation can influence the DSE results in greater extent. Data synergy for the heterogeneous data, tackling the limitation in communication infrastructure with robust computing technique and better interaction and optimum information sharing between TSO and DSO are the key issues in the monitoring mechanism of the modern power system. A general working flow diagram for an advanced automation possibilities with application of observability analysis and SE is shown in Figure 2-1.

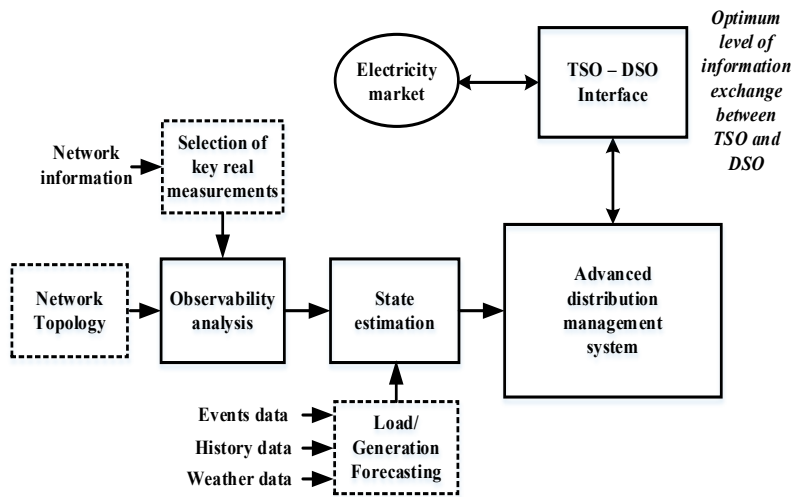

Figure 2-1 Advanced automation possibilities in distribution system using improved network observability, SE and its application in active distribution management system

2.2. NETWORK MEASUREMENTS AND OBSERVABILITY

Distribution grids are complex and are of diverse structures in the power system typically from 230/400 Volts in LV to 60kV in MV level. Traditionally they are designed to transport electric power from the transmission network to the respective consumer locations unidirectional. However, in the contemporary system the power flow at distribution network is bidirectional with increased uncertainty due to the increased penetration of DG/RE and demand response programs at distribution level (at both MV and LV level), which are the main culprit of modern power systems [20]. Therefore, the observation of system state i.e. voltage magnitudes (V) and angles (θ) at every bus is essential for the security assessment as a compulsory task for the power system operators. Observability analysis ensure the possibility of estimation of required system states with available measurements.

Specifically, there are two approaches for observability assessment namely topological approaches and numerical approaches [21], [22], [23]. Apart from these two methods, some alternative procedures have also been applied for the observability assessment in distribution system. For example: probabilistic approach by defining probability index, graph theory approach by using graph theoretic criterion for local observability assessment in DN etc. [24]. Regardless of the approach used, observability of the network mainly depends on the types and number of measurements as well as their location. For the analysis with the topological approach, decoupled measurement model and graph theory is used [21]. Whereas for the numerical approach both coupled as well as decoupled measurement models can be used. The numerical approach is based on numerical factorization of the measurement

Jacobian/gain matrix [21]. Both methods work well if there is availability of sufficient number of measurements as in transmission networks. But in distribution systems specially in MV grid there is less number of measurement devices due to economic reasons [25] so they are operated with reduced observability. On the other side, there are huge measurement facilities in LV grids almost from each load point because of the development of advanced metering infrastructure and application of smart meters. As an example, after 2020 more than 80% of the electricity meters in EU will be replaced by smart meters [14], [26]. So, the key challenge is to observe the network with accurately estimated states using only smartly selected minimum number of measurements from crucial locations [22]. Observability challenges in distribution system can be tackled from different standpoints. In [27] the direct numerical method evaluated in a non-iterative manner is described. It uses the information from selected rows of inverted gain matrix. Observability analysis based on the computation of null space of measurement Jacobian matrix is explained in [28] whereas concept of formulation of new intermediate working matrix is explained in [29]. Unobservable branches can be identified by calculating the dependent column of gain matrix [23]. By removing all unobservable branches, observable islands can be determined. These islands can be merged to form single observable island by considering the measurements from their boundary.

2.3. STATE ESTIMATION

State estimation is a technique to access the value of unknown system state variables utilizing the known measurements. Due to limited availability of real-measurements in distribution grid, either they are operating with reduced observability or their observability is achieved with the help of pseudo-measurements. Distribution companies are reluctant to implement DSE even today because of the not-guaranteed observability in their entire system. Application of real time measurements and estimation verification have significant impact on quality of estimated results [30], [18]. Specifically in distribution network, its characteristics itself are challenging for DSE implementation for example [31]:

- More likely to have imbalance in network
- Radial or weakly meshed topology
- Low number of measurement devices in MV grid and huge measurements in LV
- Low X/R ratio
- Massive nodes in the network
- Network model uncertainty

In literatures, several approaches for observation and monitoring of the power system network using estimated states are available [20],[32], [33], [34], [35]. A branch current based state estimator that is not effected by line R/X ratio is proposed in [32]. It utilizes branch current measurements that are quite common in distribution system. This technique is a modified version compared to the node voltage based method that

is used in transmission networks. Its drawback on voltage handling capability is improved in [33] by using magnitude and phase angle of branch currents as state variables to estimate load at every node. However, minimum meter placement and observability assessment prior to state estimation were not carried out in both cases, so they have used a large number of measurements. Challenges and requirements for the emerging scenario is highlighted in [34]. One of the challenge is the availability of huge data from innumerable smart meters in LV network. There is a risk that DSOs might be burdened with huge data in future. Preferably, only the key data has to be processed by the DSO control center to trace out the information for actionable intelligence to observe the network in real time.

2.3.1. AVAILABILITY OF DATA FOR DSE

Accessibility and the implementation of advanced technology have induced the data variety and availability in the modern distribution system, which are listed below but not limited to [18]:

1. Network information and equipment connectivity status from GIS.
2. Real time measurements (E.g.: Current, voltage, active/reactive power flow etc.) from smart meter, RTUs, IEDs, PMUs, SCADA system etc.
3. Demand and generation history etc. from Data hub and weather information from metrological station.

2.3.2. MEASUREMENTS APPLICABLE TO DSE

Generally, three types of measurements can be used for state estimation:

1. **Real Measurement:** These are the real time measurements collected from the different nodes and lines of the network. Voltage, current, active and reactive power flow are the most common types of measurements collected from the network. Limited measurements (E.g. in MV network) cannot guarantee the system observability whereas huge measurements (E.g. in modern LV network) lead to data overload thus demands large bandwidth and high reliability in communication infrastructure that trigger economic problems [36].
2. **Pseudo measurements:** The estimator requires pseudo measurements when available real measurements are not sufficient to observe the system state. Forecasted load/generation profiles are used as pseudo measurements. Behaviour of load demand is dynamic because of emerging entities (E.g. EV charging, RE production etc.) at customer location behind the energy meter, which will add the uncertainty to the consumption pattern. If load demand recorded at LV nodes is aggregated to MV nodes then the uncertainty will also be reflected and deteriorate the pseudo measurements accuracy. Load classification and application of close loop scheme in which the DSE output

is fed back to the load model for model update can improve the accuracy of pseudo measurements and estimated states at the end [18],[37].

3. **Virtual measurements:** Virtual measurements are generally found in switching stations. Typical example of virtual measurements are: zero current flow in the open switch, zero voltage drop in the close switch, zero bus injection in the bus where there is no actual generation and load etc. These measurements can be handled by using Lagrange multiplier for minimizing optimization problem in SE formulation [18].

2.3.3. METHODS OF DSE

Among the proposed methods, main difference is the selection of state variables, simplification in the approach versus calculation time and capability to incorporate diverse measurements. Two main categories based on the selection of state variables are node voltage based and node branch current based [21]. Inclusive analysis on DSE shows that both branch current and node voltage based estimators can give similar accuracy. Branch current based DSE that has used linear measurement function are comparatively faster in execution if the slack bus voltage are included in the state vector. However, it can be slower than the rectangular node based methods if several voltage measurements are used since derivative of these voltage measurements with respect to branch current produce non zero jacobian elements [38]. Reference [35] highlight the application and choice of a state estimator for distribution systems based on bias, consistency and quality of estimation. It concludes that the improved weighted least square estimator is the best estimator for distribution systems but measurement optimization and observability analysis is not included in the technique.

An estimator is considered as robust if it can suppress the effect of bad data. It can be realized by reducing the weights allotted to the suspected bad data. In reality, there are abundant nodes in the distribution system together with many pseudo measurements that have higher weights, which has to be considered in the new DSE [39]. For the bad data detection, particle swarm optimization and genetic algorithm based technique can be used. If recursive estimation is carried out by using several measurement snapshots in sequence of time then it is termed as a dynamic estimator. Whereas in distributed estimation, local estimation is carried out in each section of the network that is divided based on geography, measurements locations, topology, voltage level etc. Distributed estimation is challenging for distribution networks due to limited number of real measurements (MV grid), unsynchronized measurements, and communication limitation (delay, bandwidth etc.) [40]. To ensure the availability of real measurements with less economic burden, optimal number of measurements and their locations have to be determined and embedded to the state estimation [41], [42].

2.4. FORECASTING

Forecasting is a technique to predict the future data set based on the pool of current and history data. The forecasting procedure depends on the available data. If the data is not available for the forecasting then a qualitative forecasting technique is followed, where well-developed structured methods such as judgmental forecasting are used [43]. However, if we have history of data available and it is quite reasonable to assume that forecasted profile can follow the trend, then the quantitative forecasting method can be used. Most of the quantitative forecasting methods uses time series data (interval of time series or collected at some point of time) [43]. Forecasting can be for different time horizon: short term (hour-day-week), medium term (week-month) and long term (month-years) based on the applications such as operation and control, near future operation planning or long term planning respectively [44]. For medium and long term forecasting end use and econometric approach is used. Several techniques and models for short term forecasting are available in literatures such as regression models, similar day approach, statistical learning algorithms and time series approach etc. [43]. Usually ARIMAX (autoregressive integrated moving average with exogenous variables), ARMAX (autoregressive moving average with exogenous variables), ARIMA (autoregressive integrated moving average) and ARMA (autoregressive moving average) are the most commonly used conventional time series techniques. ARMA and ARIMA uses only history of time series load as input parameters but future load depends on weather and many other factors (social events, holidays, time of day or week, seasons, type of load etc.) so ARIMAX is a superior tool among the other time series tools [45], [46]. Some artificial intelligence based methods such as expert system, fuzzy logic and neural network are also available in the literature that can be used for short term forecasting too [47]. ANN based models are gaining high interest and are extensively used by the electricity utilities since 1990 [48]. Advantages of ANN technique are [49]:

- Outstanding capability for function approximation and data classification.
- Can detect dependencies with historical data without any explicit regression model.
- Can represent both linear and non-linear relationship and can acquire these relationships directly from data model.

While applying the ANN to electrical load forecasting, selection of architecture, number of elements layers and connectivity, input and output data format have to be declared first. Generally, back propagation architecture, which is a continuous valued function and supervised learning, is used in electric load forecasting rather than Hopfield or Boltzmann machine [45]. In supervised learning, actual weights assigned to inputs parameters are calculated from linking historical data with outputs via training sessions. A three layer ANN model is reported in [50] for a Greek electric utility and multi-layer model in [51], both uses only three input variables: history of load, weather information (temperature), seasonal information or day of the week. It

has been further developed and the use of weather ensemble estimate in the ANN based load forecasting model have been investigated in [52], [53]. Further, in [54] technique to construct the prediction intervals is described. It has used extended lower upper bound estimation (LUBE) to form the prediction intervals using NN models and are applied for both load as well as generation forecasting. ANN based models can also be extended for electricity price forecasting too [55]. To get more accurate load forecast, apart from selecting the proper method, some other factors other than history of load also have to be considered. These factors can significantly influence the demand pattern. Examples of these factors are shown in TABLE 2-1 [45], [49].

TABLE 2-1 Other factors that can influence the forecasting

S. N.	Influencing factor category	Descriptions
i.	Time factors	<ul style="list-style-type: none"> a. Time of the year, the day of the week, and the hour of the day b. Holidays and social events schedule c. Week days (even within weekdays different in different days like Monday and Friday) and weekends
ii.	Weather data	<ul style="list-style-type: none"> a. Temperature b. Humidity c. THI (temperature-humidity index) - THI is a measure of summer heat discomfort d. WCI (wind chill index) - WCI is cold stress in winter
iii.	Customer classifications	<ul style="list-style-type: none"> a. Residential b. Commercial c. Industrial

Influencing factor's closeness with forecasted demand profile can be identified by evaluating the correlation index for the respective variables. TABLE 2-2 shows the criteria to identify the closeness of respective variable with forecasted profile [56]. Thus, for a particular network or area, less influencing factors can be filtered out and only most influencing factors can be selected for the further treatment in the ANN model, which will minimize the computational burden and increase the prediction accuracy.

TABLE 2-2 Correlation index and its meaning

Correlation Index (R)	Meaning
$0 \leq R \leq 0.09$	No relation
$0.1 \leq R \leq 0.25$	Small relation
$0.26 \leq R \leq 0.4$	Medium relation
$0.41 \leq R \leq 1$	Strong relation
$-1 \leq R \leq 0$	Negative relation
$R = +1$	Perfect relation
$R = -1$	Perfect negative relation

2.5. ADVANCE DISTRIBUTION MANAGEMENT SYSTEM

ADMS is a compact software solution developed for the distribution system operators to handle emerging scenario i.e. situation explained in section 1.4. Main aim of ADMS is to provide grid monitoring, management and control solution for active distribution grids specially for LV network [57]. By implementing ADMS, more secure, efficient, and reliable operation of distribution grid can be achieved even in emerging scenario[58]. General ADMS architecture and functionalities can be grouped in to four modules such as: (i) Collection of data (source, model, big data handling capability and information that can be traced from the data). (ii) Processing of data (aggregation, correlation and state estimation). (iii) Final application of processed information (E.g.: for loss observation, characterization and minimization; Control applications etc.) and (iv) Human machine interface (HMI) [57], [59]. Ideally integrated mechanism of distribution management system (DMS) and outage management system (OMS) in the modern power distribution system is the ADMS [60], [61], [62].

2.6. UTILITY INTERFACE (TSO-DSO-MARKET) IN NEW SCENARIO

Assessment of utility interface i.e. TSO, DSO and Electricity market coordination for operation and planning is gaining stakeholder's interest in the emerging power system. Key challenge is to access the existing cooperation status and identify the procedure to handle technical and non-technical operational issues effectively. In this regard, it is evident that TSOs and DSOs have to handle new responsibilities in different ways in future [63]. Reference [64] provides the guidelines for the operation of future active distribution networks and enable the TSO to access the ancillary services from DER at distribution networks. These guidelines are more focused to the level of control and automation required to best utilize RE based DGs from both TSO and DSO perspectives where non-technical issues are not covered. Key topics of interest (e.g.: congestion management, voltage support, balancing the grid etc.) for utility cooperation in smart grid scenario have been highlighted in [65] by assessing

the scenario of a couple of European and American countries. More specifically, impact of flexibility (price and quantity) offered by active distribution system in the ancillary service market have been assessed in [66]. Dual scheduling (planning and operation) framework for TSO and DSO considering local uncertainties is proposed in [67] whereas possible interaction scenario between virtual aggregator, TSO and DSO is discussed in [68]. Further investigation on utility interface is still open such as: Can grid monitoring be able to boost the interaction between utilities? What and how much information should be collected? When (time frame) and where (sending and receiving entities in the network) the information (measurements, network states, load/generation forecasted profiles etc.) should be communicated? What is the exact planning, operational and economic benefits? etc.

2.7. SUMMARY

Over all state of the art have been discussed in this chapter, which have highlighted the necessities of network observability assessment for state estimation. Major techniques available for network observability assessment and state estimation have been discussed and their merits and demerits have been presented. Forecasting (load/generation) technique is presented for pseudo measurement modelling that are applicable for state estimation modules. Finally, concept of ADMS and requirement of utility interface in emerging scenario is also discussed. Based on the background of the discussion presented in this chapter further exploration in each modules as shown in Figure 2-1 will be presented in the succeeding chapters respectively.

This page intentionally left blank.

CHAPTER 3. IMPROVING DISTRIBUTION GRID OBSERVABILITY FOR DSE

This chapter summarizes manuscripts C3, C4, C5 and J1, which covers observability assessment, forecasting and state estimation. Network observability assessment procedure followed by DSE and their mathematical formulation is briefly described in this chapter. Once the network observability is guaranteed state estimation can be initiated. Tradeoff between accuracy of estimated states and quantity of real measurements used is also covered in this chapter.

3.1. OBSERVABILITY AND METER PLACEMENT

Any electricity network is said to be observable if all selected network parameters (E.g.: voltage at each bus) can be estimated based on the available measurement configuration. First step of the observability assessment is to select estimating variables and prepare the list of measurement options i.e. type of measuring variables, measurement locations, their combination e.g. PI or PV or PQ or PVI or PQV etc. where P Q V I stands for active power, reactive power, voltage and current magnitude respectively. Selection of proper measurement option will reduce iteration cycle and give minimum estimation error up to some extent [69]. This is a one time job for a particular network set up and no need for repetitive analysis is required. After this preliminary assessment, the actual network observability assessment is initiated based on the chosen measurement set up. The measurement model can be expressed in terms of the vector equation as given in equation (1) and its gain matrix in equation (2) [21], [70], where ‘e’ is measurement error, ‘H’ is measurement jacobian matrix, ‘ α ’ is incremental change, ‘G’ is the gain matrix of the measurement model. ‘H’ and ‘z’ is difference between measured and calculated value of the measurement.

$$z = H\alpha + e \quad (1)$$

$$G = H^T H \quad (2)$$

Let us assume the measurement covariance matrix as an identity matrix. Even for a fully observable system, rank of H will be at most equal to the number of buses (n) minus one if the slack bus is included in the formulation. Hence, it is expected that triangular factorization of the gain matrix G will be interrupted by at least one zero pivot. The case with first zero pivot can be expressed as equation (3).

$$= \begin{bmatrix} d_1 & & & & & \\ & d_2 & & & & \\ & & \ddots & & & \\ & & & d_i & & \\ & & & & 0 & \dots & 0 \\ & & & & \vdots & \times & \times \\ & & & & 0 & \times & \times \end{bmatrix} \quad (3)$$

Here, $G_A = L_i^{-1} \cdot L_{i-1}^{-1} \dots L_1^{-1} G L_1^{-T} \dots L_{i-1}^{-T} L_i^{-T}$ where L_i represents elementary factors that are given by:

$$L_i = \begin{bmatrix} 1 & & & & \\ & \ddots & & & \\ & & 1 & & \\ & & & \ddots & \\ & \times & & & \\ & \times & & & 1 \end{bmatrix} \quad (4)$$

In equation (4), the i th column has non zero elements below its diagonal (\times). Now, by setting $L_{i+1} = I_{n \times n}$ Cholesky factorization of G_A can be carried out which yields a singular and diagonal matrix D that will have zeros in all rows corresponding to zero pivot. This process has to be repeated until the zero pivot is detected for complete factorization. A function of non-singular lower triangular matrix can be used to represent D , which is given in equation (5).

$$D = L_n^{-1} \cdot L_{n-1}^{-1} \dots L_1^{-1} G L_1^{-T} \dots L_{n-1}^{-T} L_n^{-T} = L^{-1} G L^{-T} \quad (5)$$

If we add new measurement to the existing measurement set, a new row h_k will be added in the measurement Jacobian matrix. Then gain matrix G_A will also be modified accordingly [70]. If number of zero pivot is equal to one then the network is identified as observable and state estimation can be initiated otherwise unobservable branches have to be identified[70]. By removing all unobservable branches observable islands can be determined and new measurement set up have to be reconfigured so that observable islands can be merged together to have the full network observability. For the new measurement set up, list of possible measurement points in the network have to be prepared, prioritized and selected[71]. Real measurements are utilized first and for the insufficient measurement if any pseudomeasurements have to be used. Pseudomeasurements here refers to the forecasted values of load and generation that can give net injection measurements at each bus. Especially in medium voltage network, due to economic reason large number of pseudomeasurements have been used for the analysis. These pseudomeasurements are calculated values and may contain large numbers of errors. Therefore, by using them, even though a network is identified as observable it can give large estimation errors. Hence, re-assessment of network observability considering accuracy of estimated states is recommended. Ratio of real and pseudo measurements to be utilized depends upon the number of

measurement devices used and level of desired estimation accuracy; it is actually a tradeoff between them.

3.2. DISTRIBUTION STATE ESTIMATION (DSE)

State estimation is the core module in the power system's security analysis, which can filter unnecessary data and give proper status of the grid. Generally, network state refers to the voltage magnitude (V) and angle (δ) at each bus. A working flow diagram for state estimation supported by observability analysis to estimate the network state is shown in Figure 3-1 [69], which shows the interlink of observability assessment and state estimation procedure.

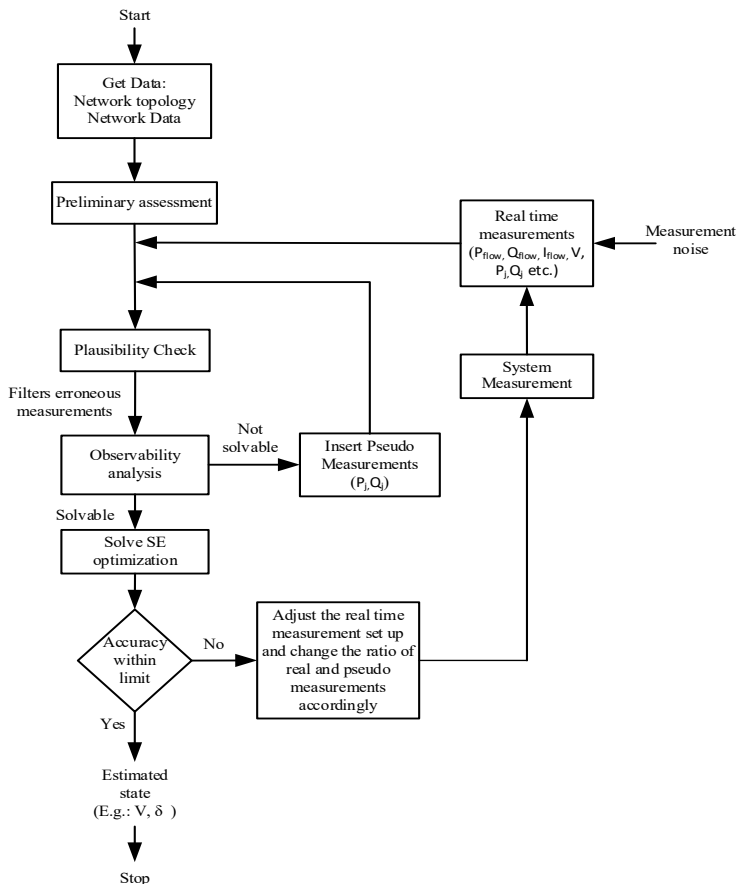

Figure 3-1 State estimation set up in power distribution network

As shown in the measurement model in equation (1), any measurement vector (E.g. 'z') is the summation of actual measurement ($h(x)$) and the error associated with same

measurement vector ‘ e_z ’ in this case. Here, $e_z \sim N(0, R_z)$ is zero mean Gaussian noise with the error covariance matrix $R_z (= \text{diag}\{\sigma_{z1}^2, \sigma_{z2}^2, \dots, \dots, \sigma_{zm}^2\})$. The normalized residual of the i^{th} measurement is defined as r_i [21]:

$$r_i = \frac{z_i - h_i(x)}{\sigma_{zi}} \quad (6)$$

where, $r_i \sim N(0,1)$. Estimator based on the maximum likelihood theory depend on the prior knowledge of the measurement error and its distribution. So, Gaussian distribution of error is considered here with zero mean and known covariance σ^2 . The general objective function ‘J’ for the estimation problem is given by equation (7) that is a summation of square of all normalized residual of measurements. Now, the estimator tries to minimize the ‘J’[21].

$$J = \sum_{i=1}^m \left(\frac{z_i - h_i(x)}{\sigma_{zi}} \right)^2 \quad (7)$$

Characteristics of different estimators is based on the selection of the r_i function. The WLS estimation technique is a quadratic form of the maximum likelihood estimation problem. To apply the WLS technique, equivalent minimization problem of equation (7) is formulated as in equation (8), which is summation of squares of the every residuals ‘ r_i ’ weighted by ‘ W_{zi} ’.

$$J = \sum_{i=1}^m W_{zi} r_i^2 \quad (8)$$

Approach to get the solution of the optimization problem (8) is the state estimator. Therefore, this estimator will minimize the objective function (9), which is independent of measurement error [21].

$$J(x) = \frac{(z_i - h_i(x))^2}{R_{zi}}$$

$$J(x) = [z - h(x)]^T R_z^{-1} [z - h(x)] \quad (9)$$

At minimum, first order optimality condition will have to be satisfied i.e. first derivative must be equal to zero. This can be represented in compact form as in equation (10).

$$g(x) = \frac{\partial J(x)}{\partial x} = 0 \quad (10)$$

An estimate of the state can be obtained from the iterative exercise using the Newton method as per equation (11). Expression given in equation (11) is obtained by expanding the nonlinear function $g(x)$ into its Taylor series, where higher terms are neglected.

$$\hat{x}_{k+1} = \hat{x}_k + (H^T(\hat{x}_k)R_z^{-1}H(\hat{x}_k))^{-1}H^T(\hat{x}_k)R_z^{-1}[z - h(\hat{x}_k)] \quad (11)$$

Where, $H(\hat{x}_k) = \left[\frac{\partial h(x)}{\partial x} \right]_{x=\hat{x}_k}$

3.3. PSEUDO MEASUREMENTS MODELLING - FORECASTING

Pseudo measurements are also measurements of the electricity grid but are not real measurement using measuring devices they are calculated values. Especially in the MV grid, it is not feasible to put metering devices at every nodes due to economic reason. Hence, pseudo measurements are required to fulfill this gap. Future load/generation profiles for given period of time that can be prepared using forecasting techniques are used for pseudo measurements required while estimating the network states as discussed earlier in section 3.2. ANN based short-term forecasting procedure considering most influencing factors like weather, historical statistics of load/generation, social/technical events etc. is proposed here. Basic steps for this method are:

- Step 1: Get history data (E.g.: history of load consumption or previous history or generation).
- Step 2: Divide the data in to two groups: test sets and training sets.
- Step 3: Design the ANN architecture and prepare the network i.e. number of input nodes, number of layers in between (with hidden layer if any) and number of output neurons [72].
- Step 3: Train the ANN network using training sets and calculate the weight of each neuron.
- Step 4: Calculate the forecasted value (y_k) as per equation (12) and calculate the error produced by ANN using MAPE as in equation (13). Here, ' u_{jk} ' is a weighting matrix, w_{ji} is weight that connects neuron i to input j, θ is bias vector and x_i represents input nodes [72], [73].

$$y_k = \sum_{j=1}^3 \left(u_{jk} \frac{1}{1 + e^{-\sum_1^4 w_{ji} x_i + \theta_j}} \right) + \theta_k \quad (12)$$

$$MAPE = \frac{1}{N_h} \sum_{N_h} APE \quad (13)$$

$$APE = \frac{|Forecasted_{parameter} - Actual_{parameter}|}{Actual_{parameter}} \times 100$$

Each model is trained with its training sets for a certain amount of iterations. After the maximum number of iterations, the model is tested by the training set. Based on test results, APE and MAPE can be calculated. Generally, if the calculated MAPE is higher than 3%, another training is carried out. This process continues until all MAPE from test results is below 3%. The training time to reach the allocated MAPE percentage depends on the size of the training vectors. For some load situation, MAPE

of the forecasted load may be found to be more than 3% if we use only history of load. So, to get more accurate load forecast we have to consider some other factors other than history of load which can influence the use of load by the consumers. Correlation analysis using equation (14) can be carried out to identify the most influencing factors (E.g.: temperature, humidity, costumer class, time of use, holidays etc.) for load forecasting. Based on the results of the correlation analysis (by comparing the value of correlation index R as per TABLE 2-2) the most influencing factors can be selected and the simulation can be repeated to get more accurate forecasting results with fast computational time. Here, 'm' and 'n' are two variables to be correlated and \bar{m} and \bar{n} are their means respectively. These factors must be analyzed separately for each new location for higher accuracy because these factors are not identical for all places.

$$R = \frac{\Sigma(m-\bar{m})(n-\bar{n})}{\sqrt{(m-\bar{m})^2(n-\bar{n})^2}} \times 100 \tag{14}$$

Application of correlation analysis in forecasting improves the accuracy of forecasted values as shewn inFigure 3-2, the typical agriculture load from Denmark [72].

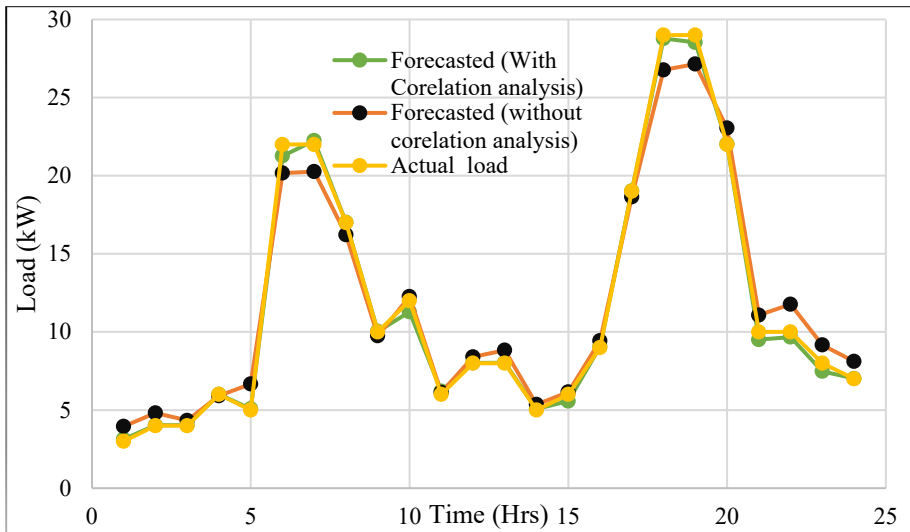

Figure 3-2 Comparison of Actual and forecasted load [72]

It is observed that MAPE of forecasted load is improved to 3.7% from 9.6% by using correlation analysis to identify most significant factors which can influence the forecasted profile as history of consumption pattern, weather (E.g.: temperature, humidity etc.), holidays and social events etc.

3.4. INTEGRATED ANALYSIS OF IMPROVED OBSERVABILITY FOR DSE AND ESTIMATION ACCURACY TRADE OFF

As discussed in section 3.1 and 3.2 the state of network for instance voltage at each nodes can be estimated once the network is classified as observable for the defined measurement set up. Now in this section method to assess the accuracy of estimation states and its relation with number of measurements used is summarized to identify the tradeoff between them as presented in [71]. Integrated operation of observability analysis followed by state estimation and its accuracy assessment is shown in Figure 3-3 [71].

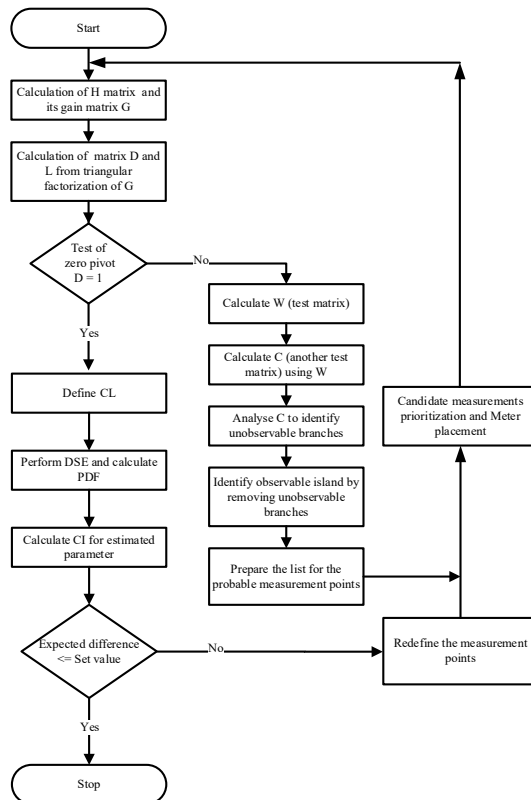

Figure 3-3 Improved observability for SE and estimation accuracy trade off evaluation

After evaluation of estimated states with the predefined confidence level, its probability density function (equation 15) is evaluated to know the confidence interval (CI) i.e. a_i min and a_i max the endpoints of CI [71]. If estimated value is not satisfied with desired accuracy level i.e. not satisfying equation (16) then it will trigger the meter placement module to give a new measurements set up and the complete process is repeated again. It means redefine the measurements locations, increase the minimum measurements from the prioritized list and proceed for observability assessment and further evaluation [71].

$$F_i(a_i) = \frac{1}{\sqrt{2\pi\sigma_i^2}} e^{-\frac{(a_i - E_i)^2}{2\sigma_i^2}} \quad (15)$$

$$\text{Maximum expected difference between } E_i \text{ and its true value} = |a_i \text{ max} - a_i \text{ min}| \quad (16)$$

For the detailed mathematical modelling and analysis on accuracy trade off evaluation please refer to [71]. As shown in Figure 3-4 [71], network is divided in to eight observable islands when the observability assessment is carried out without applying proposed bus prioritization technique even if 30 % of real measurements is used.

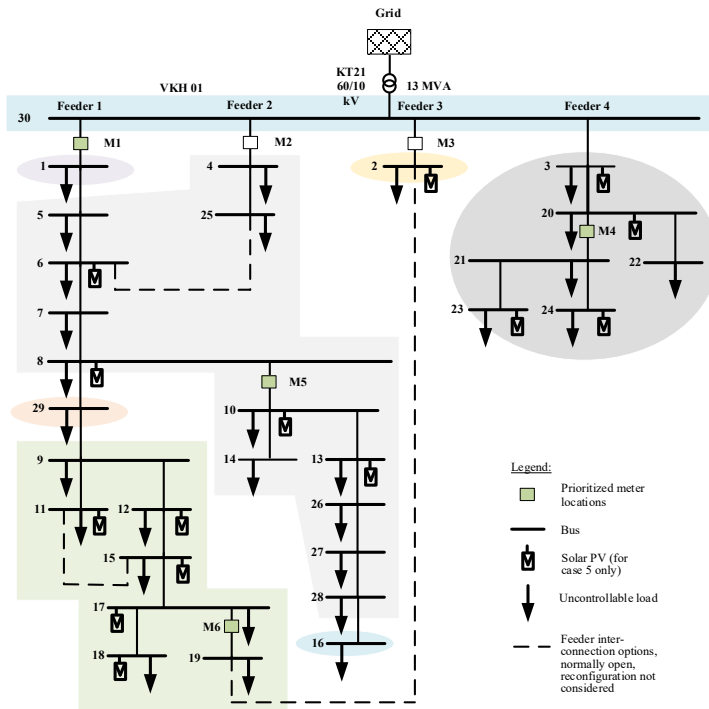

Figure 3-4 Customized Lind area network showing observable islands when bus prioritization is not considered

However, with the proposed algorithm i.e. placing meters based on their priority we can have a fully observable network with only 26% real measurements. Actually even if network is unobservable, we can estimate the network states either by using pseudo measurements for nodes without real measurements or by suspending such nodes for the estimation purpose [21]. For both cases, accuracy of estimated states depends upon the number, type and location of measurements. The proposed algorithm can ensure the accuracy of estimation states (for instance voltage magnitude) in some extent as shown in Figure 3-5, which shows the snap shot of comparison of estimated states. Maximum error of 3.9% in the estimated voltage is observed at bus 19 without applying proposed technique and is improved to 0.96% by applying proposed technique [71]. So, re-assessment of observability evaluation and state estimation considering accuracy of estimated states supported by bus prioritization technique is recommended.

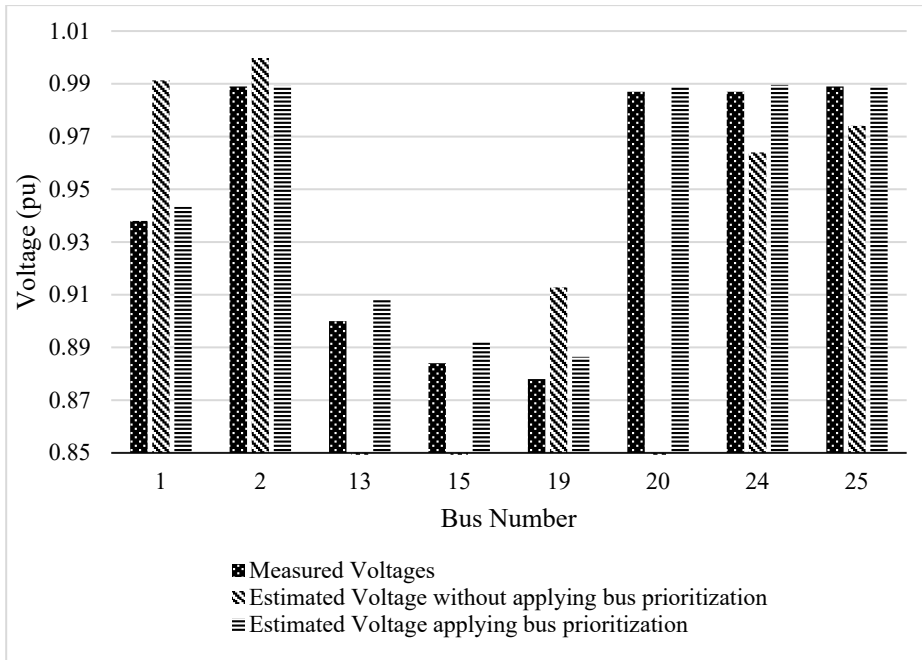

Figure 3-5 Comparison of estimated states [71]

3.5. SUMMARY

In this chapter proposed integrated observability and for state estimation approach for active distribution network is discussed. Improved observability technique considering bus prioritization concept, measurement data assessment strategy, enhanced forecasting methodology using neural network procedure and trade off analysis between estimation accuracy and applicable measurements are the key elements of the proposed approach. Simulation studies shows that proposed approach is applicable to real distribution networks which can be recommended to identify critical measuring points in MV network and critical measurement data set collected via smart meter in LV network. Assessment of possibility of application of forecasted profile and estimated network states in a close loop with control modules will be discussed in next chapter which deals about the concept of ADMS.

This page intentionally left blank.

CHAPTER 4. ADVANCED DISTRIBUTION GRID MANAGEMENT SYSTEM

This chapter summarizes the application of the concept presented in manuscripts J1 and C2, which introduces the advanced distribution grid management system. It covers the integration of observability modules (Load/generation forecasted profiles and estimated network states) with control and protection modules. Power loss observation and minimization, one of the functions of ADMS, is discussed in detail. Finally, interoperability and standards required for the implementation of ADMS are also highlighted.

4.1. ADVANCED DISTRIBUTION MANAGEMENT SYSTEM

For the implementation of any intelligent electricity system in future two major prerequisites have to be addressed at first, which are active network management and advanced grid automation. This is essential for an effective grid integration of constantly increasing amounts of intermittent RE generation technologies like wind and solar power and to realize synergy and support from flexible electricity consumption units. This can be realized by integrating load/generation forecast profiles and estimated network states with control and protection modules. To realize the overall advanced monitoring and control operation in distribution grids, a distribution grid management scheme is proposed as given in Figure 4-1. This shows the integrated operation structure for observability and state estimation modules with Control and protection modules in a close loop.

Future load/generation profiles (day ahead hourly and same day hourly) for a given period are prepared using an upgraded artificial neural network technique. Day ahead forecasted profiles are used for planning MV network control whereas same day hourly forecasted profile is used for MV/LV network control and operation. A short term forecasting technique is proposed considering weather forecast, historic load/generation statistics and social & technical events [72]. Correlation analysis is embedded in the model to identify most influencing factors for forecasting to minimize the error. The algorithm is framed in such a way that it can be used for any geographical location with respective inputs selection. Forecasted profiles are the inputs for the DSE and Level 2-3 control respectively. Real time network states are essential inputs for optimal control (volt/VAR control, transformer tap setting etc.). A network state estimator supported by grid observability analysis and minimum meter placement technique is proposed [71]. Strategic measuring points are identified using the optimum meter allocation procedure. Therefore, this algorithm ensures higher

accuracy in estimated states that can be readily used by control modules. The output of the robust DSE model and forecasting model are used for the scheduling of various automation tasks of the control and protection models in distribution grids.

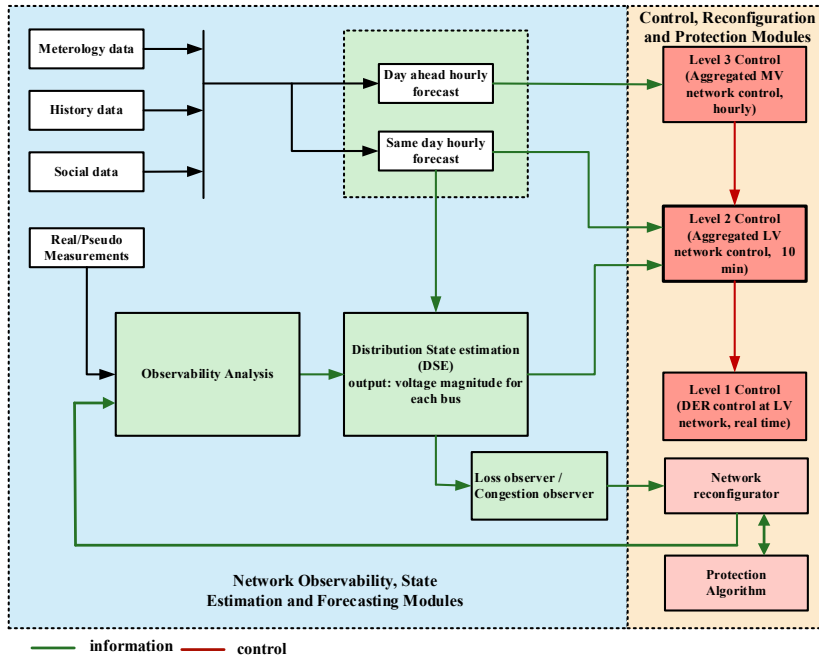

Figure 4-1 Conceptual block diagram for ADMS

Observability and SE modules are integrated with the multi-level control architecture which consists of three levels of hierarchical control framework. The functions and the appropriate control methods to be used in each control level are out of scope of this chapter. Only close loop operation of different entities in ADMS are highlighted here. For a detailed description of control methods that can be applicable in this set up please refer to [74]. Level 1 control refers to the lowest level control, which involves control of the individual devices based on the set points received from level 2 control. Level 1 control includes BESS controller, heat pump controller, EV charging station controller etc. Level 2 control refers to the aggregated LV network control, which provides control set points to the controllers of DERs connected to LV network. Level 2 control works in a close loop based on the feedback provided by the observability and state estimation modules. On the other hand, the level 3 control is the aggregated MV network control, which provides set points to each LV network controls. Control signal from level one to two and then to three are unidirectional, since each control blocks receives the information from system (estimated states and forecasting). The power loss observation and minimization module is one of the application of ADMS functions, based on which network can be reconfigured for

optimized operation. Details of loss optimization and network reconfiguration are discussed in section 4.2. Reconfigured network set up can interrupt the protection algorithm already implemented in the network, so it has to be addressed simultaneously but details of protection algorithm are out of scope of this chapter. The proposed ADMS is tested on a modified 8-bus model of a real LV network from Lind area Denmark. The network details and set up is given in Figure 4-2, TABLE 4-1 and TABLE 4-2. Figure 4-3 and Figure 4-4 shows the forecasted load and estimated voltage profiles of the test network. For instance, forecasted profile of commercial loads and estimated voltage in all eight buses are shown. Forecasted and estimated profiles are forwarded to control blocks.

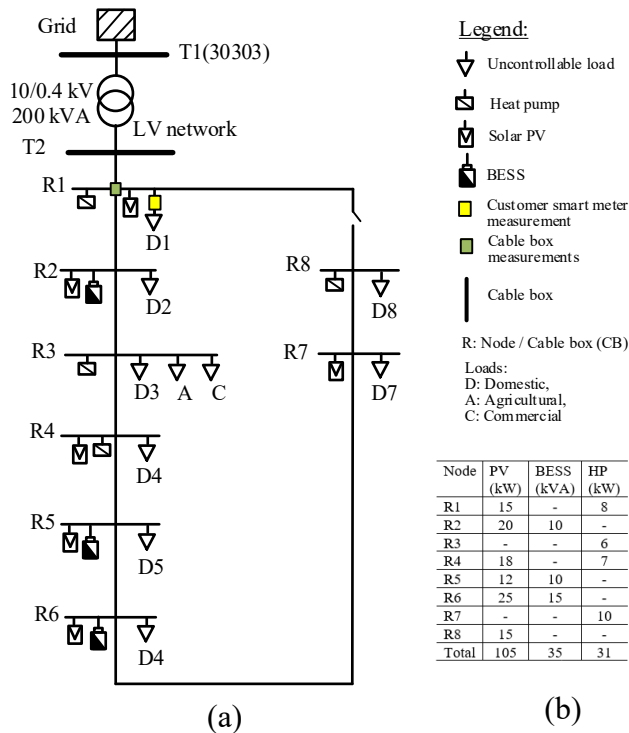

Figure 4-2 Modified LV network from Lind area

TABLE 4-1 Network data - Load details

S. N.	Cable box number	Connected load no.	No. of Houses	Assumption: load on each house (kW)	Total load at cable box (kW)
1	CB1	2, 9, 7	3	5	15
2	CB2	4, 11	2	5	10
3	CB3	6, 8, 13	3	5	15
4	CB4	10, 15, 17	3	5	15
5	CB5	12, 14, 16, 21A, 21B	5	5	25
6	CB6	18, 20	2	5	10
7	CB7	5A	1	5	5
8	CB8	13, 15, 17	3	5	15

TABLE 4-2 Network data – Line details

S. N.	Line	Length (meter)	R (ohm/km)	X (ohm/km)
1	T2 – CB1	102	0.208	0.068
2	CB1 – CB2	51	0.207	0.084
3	CB2 – CB3	25	0.207	0.084
4	CB3 – CB4	40	0.207	0.084
5	CB4 – CB5	43	0.207	0.084
6	CB5 – CB6	55	0.207	0.084
8	CB6 – CB7	63	0.641	0.072
9	CB7 – CB8	142	0.641	0.072

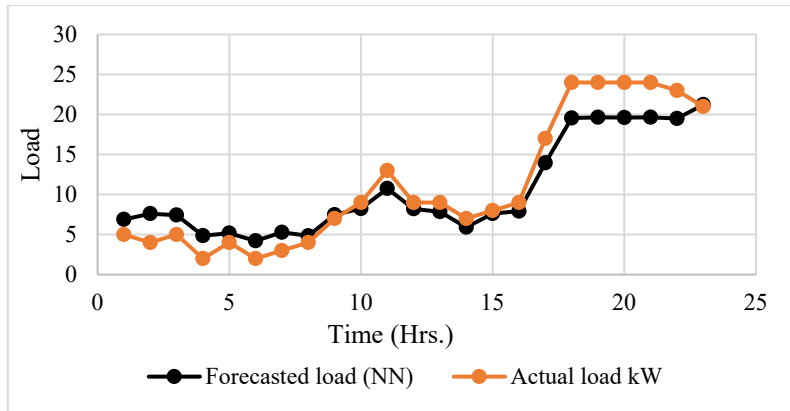

Figure 4-3 Actual and forecasted load (Commercial) for 24 hours

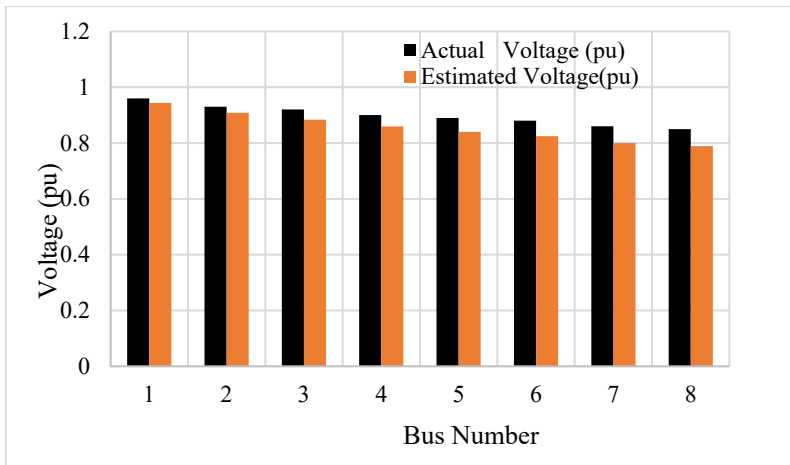

Figure 4-4 Estimated voltages in all eight buses

Forecasting and state estimator modules are interlinked with multi-level control (level 2 and level 3 control) as shown in Figure 4-1. The integration of these modules are done in MATLAB/Simulink platform. All control blocks gets reference inputs (reference power at the substation), disturbance inputs (actual loads and generation) and prediction inputs (forecasted loads and generation) based on their respective functions. The outputs of the level 2 control block (power setpoints) are sent to level 1 control for BESS and heating system. It can be seen in Figure 4-1 that some selected real measurements (e.g.: branch power flows, current flows, voltage at each nodes etc.) are passed to the state-estimation block. In addition, pseudo-measurements i.e. forecasted load/generation at each bus are also supplied to cover the scenario of unavailability of real measurements in real operation. The state estimator estimates all the bus voltage magnitudes. Then in next time-step, the estimated voltage values are

passed on to the control block. The simulation model is based on RMS values with a time-step of 10 min.

The estimated results of the DSE block are compared with the actual voltages (results of load flow calculated using Newton-Raphson method) at each time-step and the error values are plotted in Figure 4-5. With only one real measurement i.e. branch power flow measurement (at branch T2-R1) and 18 pseudo measurements error in SE is less than 0.08 pu. This is one of the worst-case scenario in state estimation, where only one real measurement (i.e. line flow) at bus 1 is considered. It can be significantly improved (up to less than 1%) by adding one more measurement (voltage) at a strategic location as per the algorithm discussed in chapter 3 which presents the detailed analysis on meter placement, state estimation and estimation accuracy trade off.

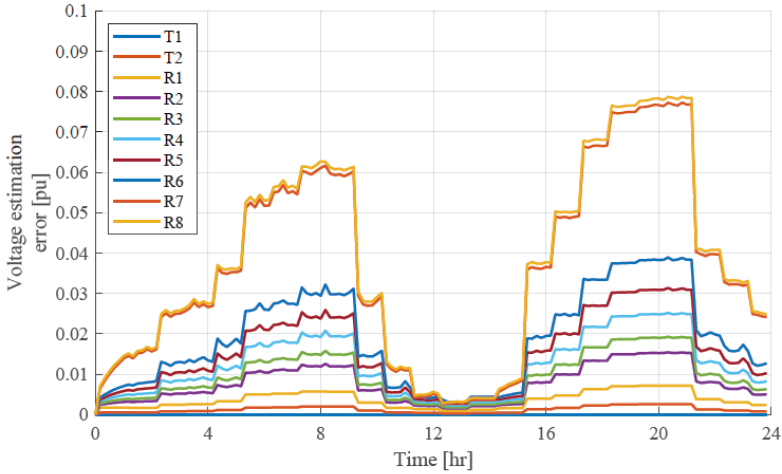

Figure 4-5 Error plot in SE when operated in close loop with control algorithm

4.2. LOSS OBSERVATION AND MINIMIZATION

Loss observation and minimization is one of the application modules of ADMS. Estimated network parameters can be used to observe the power loss in the network. For instance, line current flowing in the branch between the bus i and bus j can be calculated using estimated bus voltages as per equation (1) [21]. Where, V_i , V_j , θ_i and θ_j are the estimated voltage magnitudes and phase angles respectively at buses i and j . θ_{ij} is the difference between θ_i and θ_j . $(g_{ij} + jb_{ij})$ is the series admittance of the branch connecting buses i and j . Shunt admittance is neglected in this formulation. Once branch current flow is known, power loss in each branch can be calculated for

example active power loss as I^2R where I is branch current flow and R is the branch resistance.

$$I_{ij} = \sqrt{(g_{ij}^2 + b_{ij}^2)(V_i^2 + V_j^2 - 2V_iV_j \cos \theta_{ij})} \quad (1)$$

Delivery of power with minimum loss in the network is the main goal for efficient network operation, which is addressed in this work by developing an optimization problem considering network reconfiguration, DG and storage facility in the distribution grid. The DSO request for optimum network configuration with minimum loss is processed by solving optimum power flow (OPF). The Interior Point Method is used to solve the OPF problem due to its reliability, speed and accuracy. For the illustration of proposed method let us consider the model as shown in Figure 4-6 [75]. It shows the single line diagram set up, where line is represented by Π model and switch S1 and S2 are considered as open in normal operating condition.

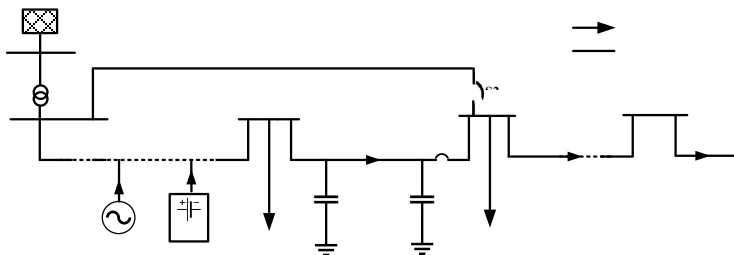

Figure 4-6 Generic model of distribution grid with DG and BESS at arbitrary location [75].

Power loss in the branch between the nodes 'k' and 'k+1' is represented by equation (2), whereas summation of losses in all branches in the particular feeder gives the total power loss ($P_{T,Loss}$) in that feeder as shown in equation (3).

$$P_{Loss(k,k+1)} = R_k \cdot \frac{(P_k^2 + Q_k^2)}{|V_k|^2} \quad (2)$$

$$P_{T,Loss} = \sum_{k=1}^n P_{Loss(k,k+1)} \quad (3)$$

Power loss in the network can be minimized by considering:

- Reconfiguration of the network: By feeder switching (using S1 and S2) or rerouting of power.
- Altering the DG penetration level: With proper level of DG penetration based on respective network configuration.
- Altering the location of storage system: By optimum placement of storage system e.g. applying loss sensitivity analysis to identify candidate node for storage system placement.

Now, total power loss is calculated for all these considerations respectively. Then, a hybrid optimization strategy is formulated by calculating power loss reduction in each considerations as given by equations (4 - 6). For details of network parameters for the equation 2 – 6, please refer to [75].

$$\Delta P_{Loss}^R = P_{Tloss} - P'_Tloss \quad (4)$$

$$\Delta P_{Loss}^{DG} = P_{DGloss} - P_Tloss \quad (5)$$

$$\Delta P_{Loss}^{Storage} = P_{storage, Loss} - P_Tloss \quad (6)$$

Maximum power loss reduction in the network means network operation with minimum losses. Hence, the overall objective function for the optimization problem has been formulated to maximize overall power reduction on the network as below:

$$\text{Maximize overall loss reduction} = \max. (\Delta P_{Loss}^R + \Delta P_{Loss}^{Storage} + \Delta P_{Loss}^{DG})$$

Subject to:

$$V^{\min} \leq V_k \leq V^{\max}$$

$$T^{\min} \leq T \leq T^{\max}$$

$$|I_{k,k+1}| \leq |I_{k,k+1}^{\max}|$$

$$\sum_{k=1}^n P_{Gk} \leq \sum_{k=1}^n (P_k + P_{Loss,k})$$

For the detailed description of the proposed methodology and analysis please refer to [75]. This generic technique can be applicable to any distribution network. For instance, it is applied to the 14 buses MV test network [75] and results are shown in Figure 4-7 [75] and Figure 4-8 [75]. As shown in Figure 4-7, bus 2 is identified as a suitable location for storage allocation due to its highest sensitivity index. Comparisons of power loss is shown in Figure 4-8. Case 1 is the base case, case 2 is the minimum power loss when only reconfiguration is considered, case 3 shows the minimized power loss with DG by maintaining the optimum network reconfiguration identified in case 2. Finally, the proposed hybrid algorithm is applied and power loss in the network is found to be minimum among the others as shown by case 4.

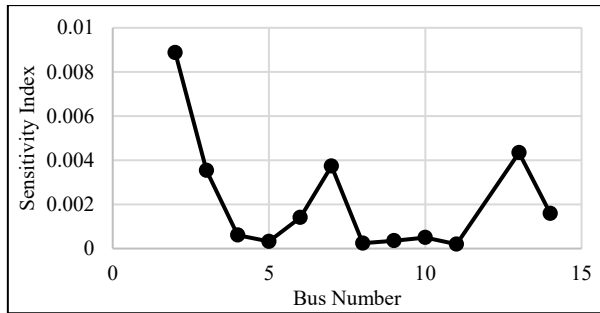

Figure 4-7 Plot of sensitivity index for storage allocation



Figure 4-8 Optimized power loss in different cases

The proposed method effectively minimizes the power loss in the network without violating the voltage limit in the distribution grid. Loss minimization improvement up to 6% is observed. This method can be recommended for active distribution network expansion planning specially to identify the location of DSO owned storage system.

4.3. INTEROPERABILITY AND STANDARDS FOR ADMS

Interoperability refers to the capability of a system with two or more than two entities (network, components, data etc.) to clearly exchange information for effective operation. The proposed ADMS consists of more than two modules for integrated operation. For proper operation, interoperability in this case includes but is not limited to:

- Requirement of communication protocols and related infrastructure. E.g.: Hardware/software components, systems, and platforms that enable machine-to-machine communication.
- Specific data format required for communication protocols that will facilitate well-defined syntax and encoding.

- A mutual understanding of the meaning of the content that is exchanged between the entities.

This will facilitate the stakeholders to integrate required modules in ADMS even though they are from different vendors. Then such readily available modules or components from different supplier can be instantly incorporated with different areas of the system so that it will function in line with other components in the smart grid. In this regard, smart grid interoperability structure that can be applicable here is given in Figure 4-9 [76].

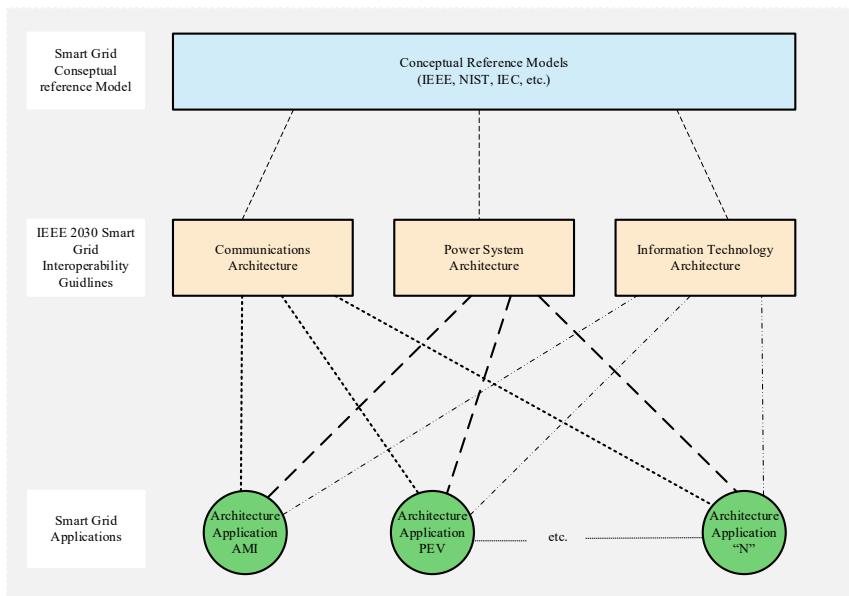

Figure 4-9 Structure for smart grid interoperability

Issues and constraints for the interoperability and its impacts have been considered during the formulation of each ADMS modules. Integrated operation is verified in simulation environment too. So, this ADMS model can be implemented in real system following the smart grid standards like IEC 61850, IEEE Std 1815(TM), IEEE Std 2030™-2011, IEEE Std 1379-2000(R2006) etc [77].

4.4. SUMMARY

In this chapter, integrated operation of network observability and state estimation module with control module is shown through simulation studies. As expected close loop operation of state estimation and forecasting in ADMS environment is found to work for few test cases. Interoperability between different modules is tested. The control modules were able to execute properly with the inputs from state estimation

and forecasting modules for flexible assets management in the network. Loss minimization technique in active distribution network is also covered in this chapter, which is one of the application function of ADMS. Hybrid optimization technique considering network reconfiguration, DG and storage allocation is recommended which give minimum loss among the others. Finally, requirement and considerations of interoperability issues for each ADMS module is presented and key smart grid protocols applicable in this case are highlighted. Demonstrative test case studies for network observability and state estimation with real measurement data from real network in Denmark will be described in the following chapter which will be followed by TSO-DSO interaction in smart grid environment.

This page intentionally left blank.

CHAPTER 5. MEASUREMENT SETUP IN THE REAL NETWORK AND ANALYSIS

This chapter summarizes the measurement set up and the test activities of the proposed integrated approach of network observability for state estimation using minimum measurements. This approach is tested in the LV / MV network from Lind area Denmark using real measurements from the field. It covers the field test set up using conventional meter placement as well as RTU installations and smart meters, data collection scenarios, result analysis/discussions and lesson learned from the field study.

In chapter 3-4, the integrated observability algorithm for SE is discussed and simulation studies were shown for both MV and LV network respectively, where the grid measurement data used for the analysis are generated values using load flow calculations in different operating scenarios. Now, the main objective of the work discussed in this chapter is to analyse the performance of the integrated algorithm proposed in chapter 3, section 3.4, Figure 3-3 with real measurement data collected from the field. For this, LV/MV distribution grid from Lind area Denmark is used and different measurement devices and equipments (conventional meters, RTUs and smart meters) have been installed in the network and measurements (node voltage, branch current flow, net active/reactive power injection in the nodes etc.) have been collected and used for the study. Meter placement details, measurement collection scenario, and the performance of integrated algorithm in the setup in LV and MV network is discussed in the proceeding sections 5.1 and 5.2 respectively.

5.1. LV NETWORK SET UP

To test the proposed algorithm[71] in LV network, a LV distribution grid supplied from a distribution transformer (10/0.4 kV) is used. Figure 5-1 shows the geographical map with transformer location 30303 and load connection in the distribution grid (blue lines) supplied by this transformer.

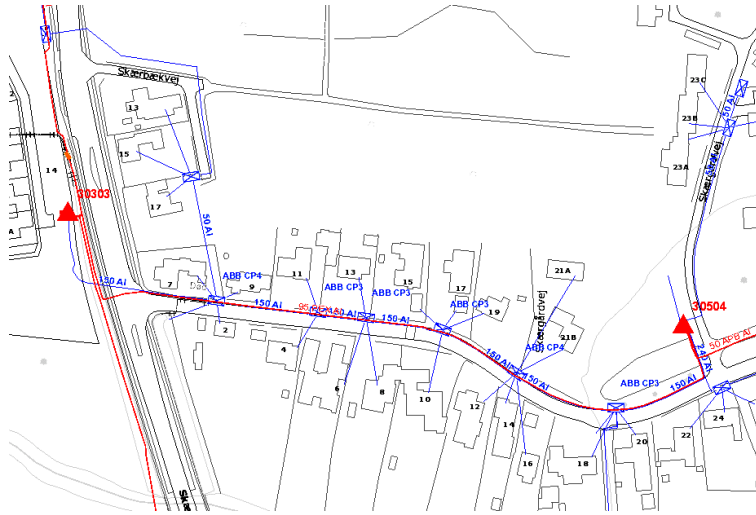

Figure 5-1 Geographical map of LV distribution grid [78]

Red lines are the medium voltage feeders connecting distribution transformers that are supplied from the substation named as VKH, which will be discussed later in section 5.2. Single line diagram of the test distribution grid with the measurement placement details in the real operating configuration of the network is shown in Figure 5-2. As shown in Figure 5-2, the distribution grid can be supplied by any one of the two transformers 30303 or 30504. Switching option is available and reconfiguration can be made as per operating requirement. The distribution grid is normally connected with transformer 30303 as represented in Figure 5-2. As per the meter placement algorithm [71] discussed in section 3.1 of chapter 3, measurement at bus with highest branches in it and total current/power flow measurement in the network are the key measurements and has high priority. Since CB1 has highest branches in it, voltage and current flow measurements have been collected from the cable box 1 and transformer station using conventional meters. Energy consumption details (P, Q, V and I) of the consumers connected to CBs are collected using smart meters at each load points. To use smart meter data as a direct input to the DSE is generally not possible due to lack of time synchronization and reliability [79]. However, these data can be used to calculate better pseudomeasurements, which is followed in this work to calculate net injection measurements at each CBs and used as pseudomeasurements. All loads are aggregated and connected at respective CBs, please refer to chapter 3 for the pseudomeasurements modelling procedure and chapter 4 of this thesis for all technical details of the test network except PV details. In the real network negligible amount of PVs are available i.e. only about 12% of the total load size in the distribution grid supplied from transformer 30303. So, impact of this PV generation on voltage at CB1 was not observed during the test period.

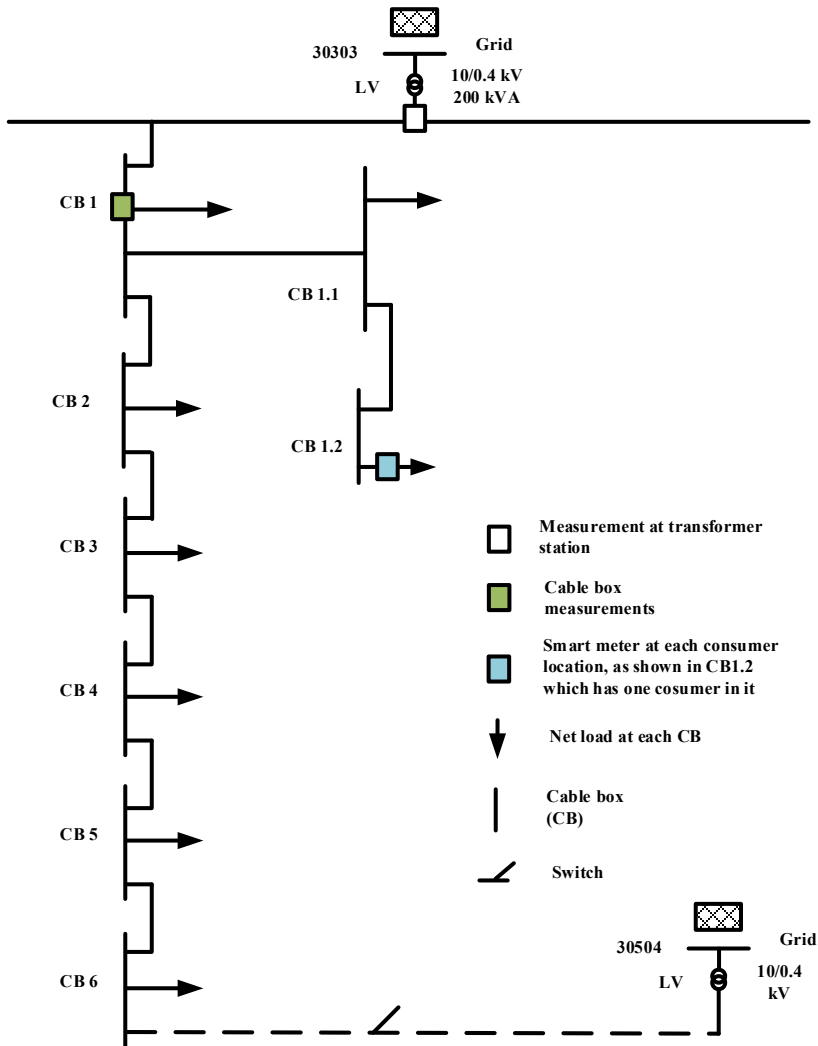

Figure 5-2 Single line diagram of the distribution grid

Typical loading profile of the residential distribution grid and voltage profile in a summer week in Denmark as observed during week 21 is shown in Figure 5-3 and Figure 5-4. Here, week day refers to 21 May 2019, Tuesday and weekend refers to May 25, Saturday.

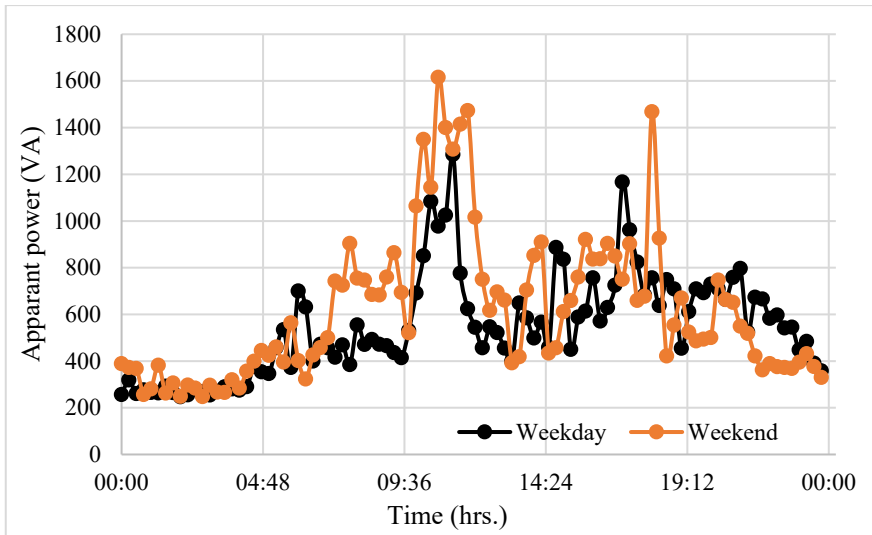

Figure 5-3 Total apparent power profile at C1 during week 21

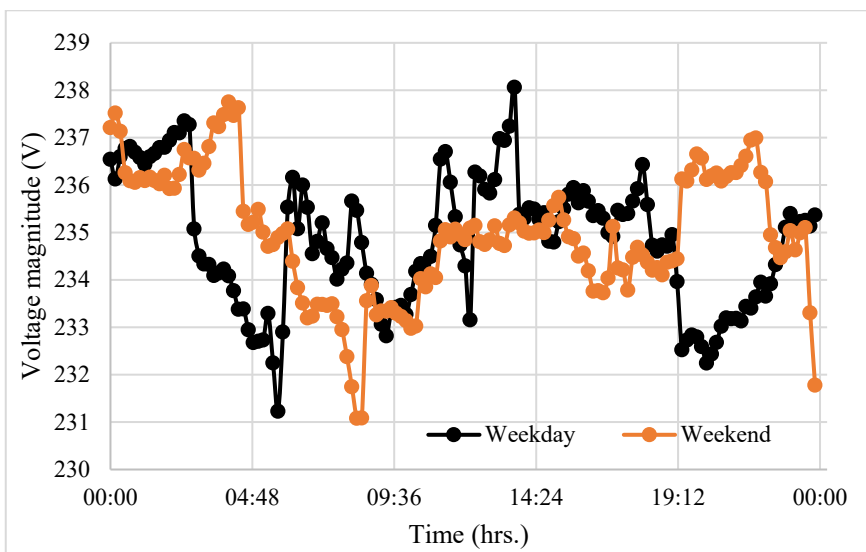

Figure 5-4 Voltage profile at C1 during week 21

It shows clearly that there is load growth in weekend and also the peaking time is also shifted slightly further as compared to week days. Impact of load variation in week days and weekend can be noticed in the voltage profile as observed in Figure 5-4. Network parameter estimation (for this case bus voltage) considering the only two

real measurements (voltage and total current flow) at CB1 have been carried out. For this study, net power injection measurements calculated using smart meter consumption data are treated as pseudomeasurements. So, in total two real measurements and eight pseudomeasurements have been used to estimate node voltages in each nodes. As shown in Figure 5-5, estimation error at CB1 in the test period have been calculated since measured voltage at CB1 is available, which is the difference between estimated voltage and measured voltage. As expected during analysis in chapter 4, almost 75% of the time in weekend error is less than 1.5% but in weekdays, slightly more error is observed, it could be due to more error in the input measurements during weekdays compared to weekends since measurement set up is fixed in both cases.

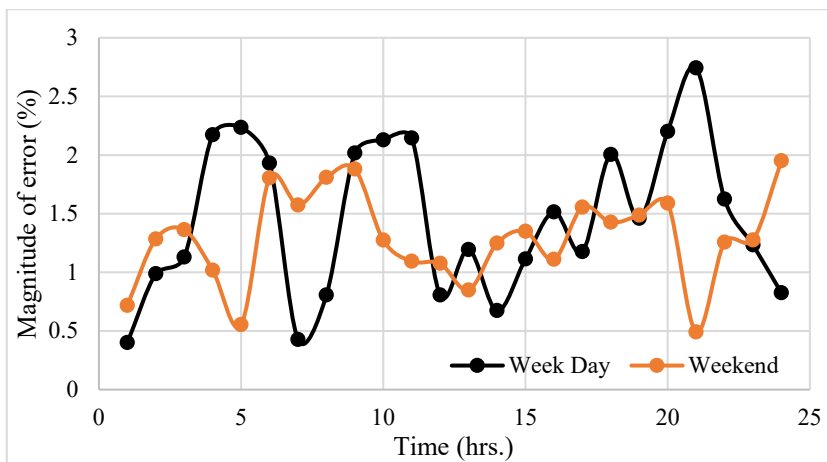

Figure 5-5 Plot of estimation error

5.2. MV NETWORK SET UP

MV network from Lind area Denmark is considered for the next test case to analyse the performance of proposed algorithm[71] in MV network with real measurement data collected from the network. There are four 10 kV feeders supplied from transformer KT21 (13 MVA, 60/10 kV) at substation VKH 01. The geographical location of VKH substation is shown in Figure 5-6. Measurement collection set up in the substation is shown in Figure 5-7 as marked by blue circles that shows the voltage measurement at secondary terminal of distribution transformer and total current/power flow measurement at the beginning of feeder 1, the longest feeder. Single line diagram of the test network with measurement placement setup is shown in Figure 5-10. This is a 52-bus MV network, which is reduced to a 30-bus network by lumping of loads but keeping the overall radial structure of network as it is in [71]. For the algorithm to identify the key locations for measurements, pseudomeasurements modelling and information about all network parameters please

refer to [71]. As discussed in [71], identified key measuring points are locations close to bus 8, 9, 10, 17, 20 and substation. Due to some practical difficulties to place the meters in the exact locations, three possible locations (3, 10, 17) for meter placement, which are close to the theoretically identified key metring place are selected. Hence, network measurements (Voltage, current flows and net power injections) are collected using three remote terminal units (RTUs) from identified nodes as shown in Figure 5-10.

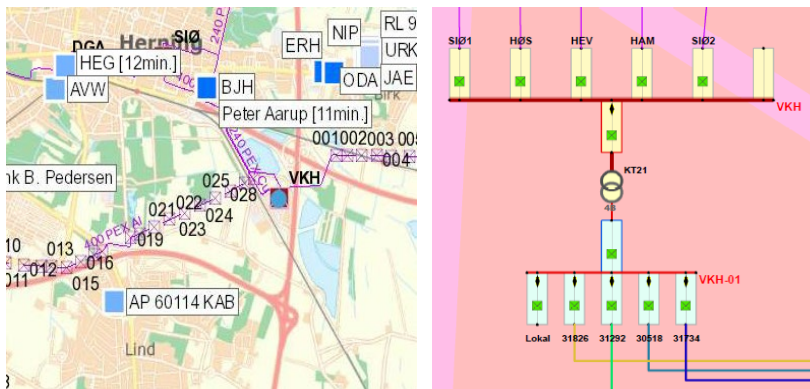

Figure 5-6 Geographical location of VKH substation (Transformer KT21: 60/10kV)[78]

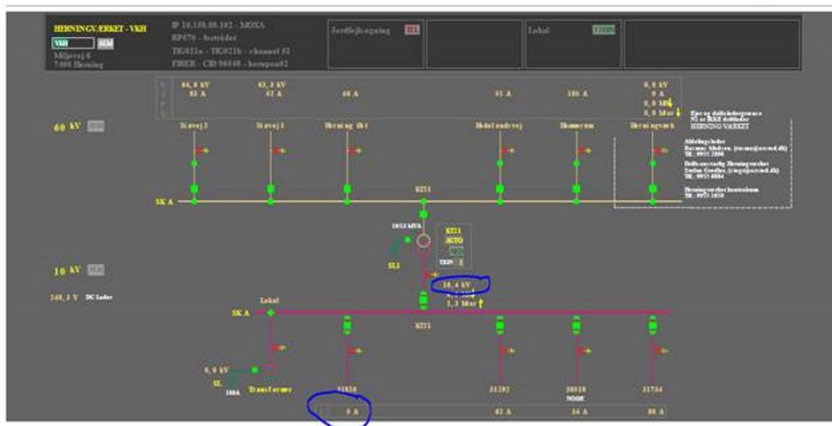

Figure 5-7 Snapshot of network showing meters at VKH substation [78]

Since, ABB is the project partner of the DECODE project and have the experience of successful implementation of RTU-based monitoring and control applications for distribution network (E.g.: Reference project in Aargau, Switzerland), ABB RTU520 components are selected for the network measurement in this work [80], [81], [82]. Together with RTU520, KEVA voltage sensor and KECA current sensor are also used for the purpose [83], [84]. Basic lay out of a RTU520 and possibility of data extraction

is shown in Figure 5-8. Data extraction option using remote desktop via micro-SCADA software installed at virtual server at AAU-IT is used in this work.

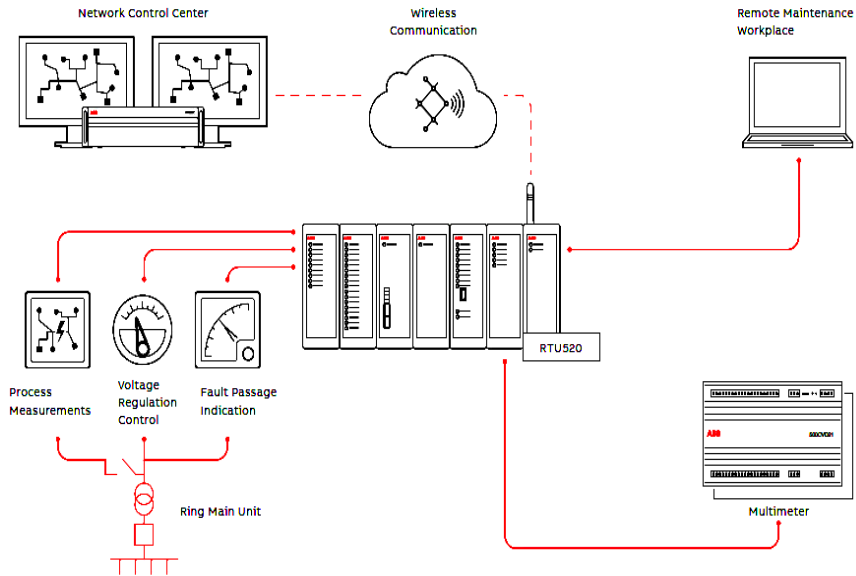

Figure 5-8 Basic layout of RTU520 and possibility of data extraction[81]

Not all the measurements recorded by RTUs can be exactly received at the working computer via remote desktop. Sample of data loss is shown in Figure 5-9. Almost 48% data have been lost on these two particular days (28th and 30th June 2019).

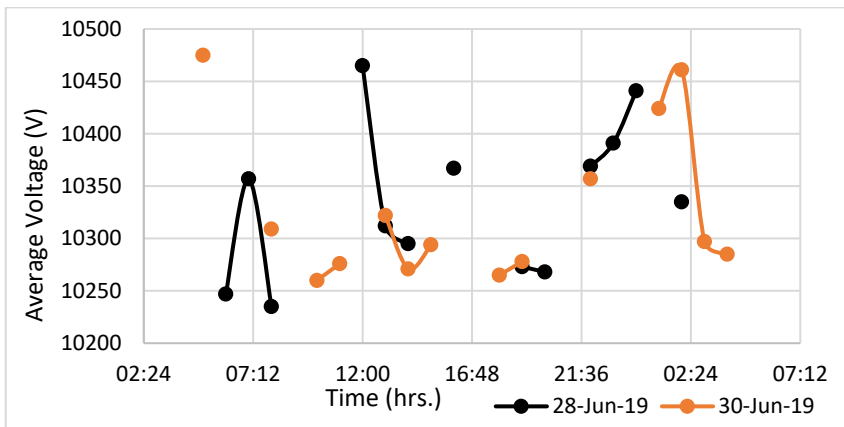

Figure 5-9 Sample of measurement loss: observation on bus 10

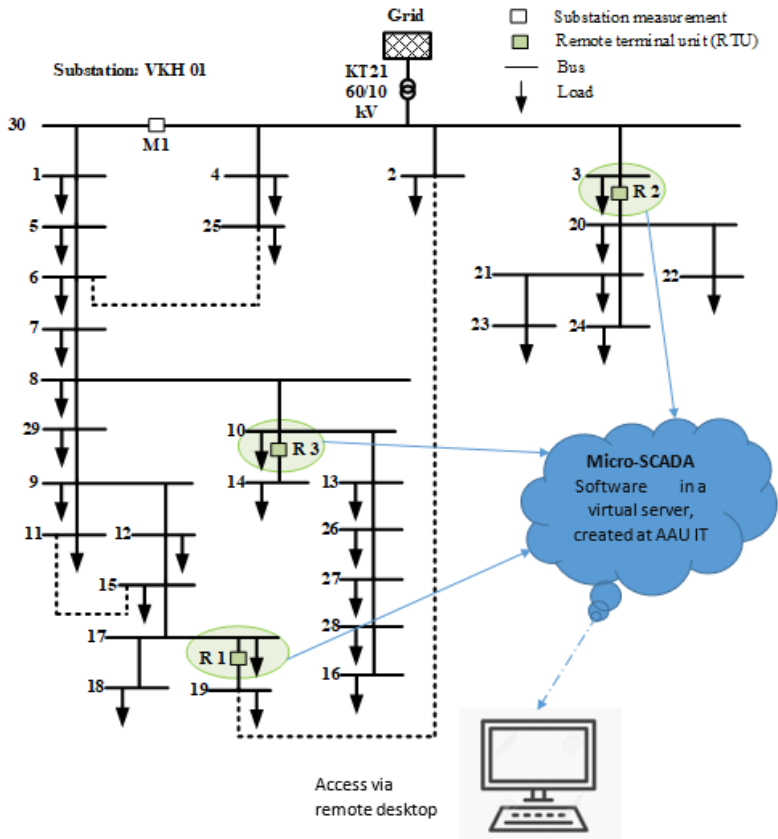

Figure 5-10 Single line diagram of MV network with measurement setup

It is noticed that there is no symmetrical pattern of data loss from all three RTUs but maximum data loss is observed from RTU3. Reason for high data loss from RTU3 could be due to unavoidable service work close to RTU3 area, which might have disrupted data communication via RTU3. Similar but less data loss have been observed during other test days as shown in Figure 5-11 and Figure 5-12.

With this set up, real measurements (Substation voltage, total current flow in the feeder1, net power injections and branch current flows at three RTU locations) from four nodes in the network are available for the analysis. For the rest of the node measurements, net power injection measurement in each node is calculated and treated as the pseudomeasurements. History of hourly power profile in each node is used to generate the pseudomeasurements for the test period. Please refer to [72] for the detailed procedure of pseudo measurement modelling. Applying these measurements data set voltage magnitude in each node is estimated as per the algorithm stated in chapter 3, section 3.2. Error in estimated states have been

calculated as the difference between measured voltage and estimated voltage. Estimated voltage at three nodes 3, 10 and 17 have been compared with actual measured values available in these three nodes and error in each hour have been calculated for June 1 as shown in Figure 5-13.

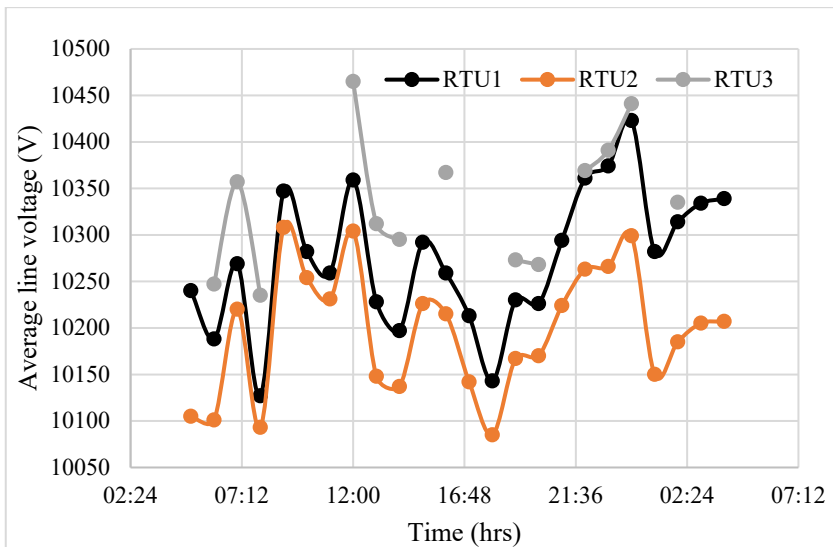

Figure 5-11 Voltage profile observed at three measurement locations on 28 June 2019

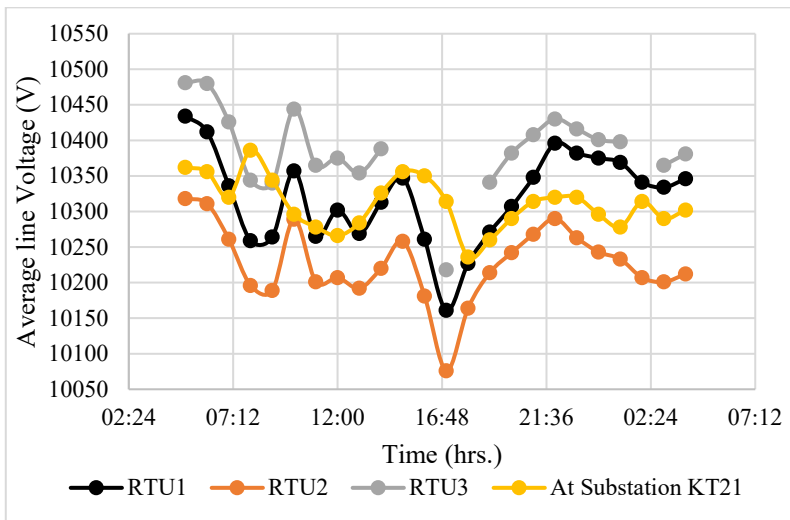

Figure 5-12 Voltage profile observed on June 1

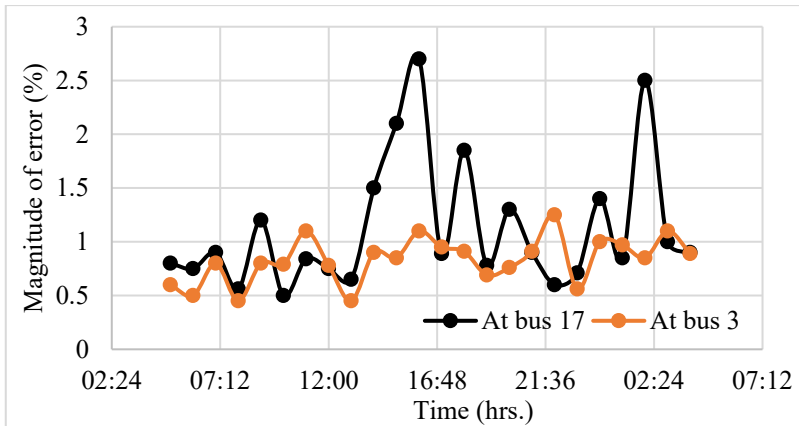

Figure 5-13 Impact of data loss on voltage estimation on June 1

As observed in Figure 5-12, data loss from RTU3 is in between 13:00 – 16:48 and 23:00 – 03:00 hrs. Estimation error distribution in Figure 5-13 shows that error is scaled up during the data loss duration. It is noticed that estimation error is less than 1.5% for bus 3 which is not in the same feeder where RTU 3 is located so almost negligible impact of data loss have been noticed there. But, for the bus 17 which is in same feeder, during the period when data loss have been noticed, estimation error have been observed to be more than 1.5%. It shows that impact of measurement loss in estimated states is less in the neighbouring feeder than in the same feeder where meter is located whose data is lost.

5.3. CONCLUSIONS AND LESSON LEARNED

Network observability for state estimation approach discussed in chapter 3 have been applied to a real Danish network with real measurement data. Network status in different operating time and days have been observed. It is noticed that with selected minimum real measurement, status of the network can be observed although error is slightly more than simulation studies in chapter 3. This could be due to shift of data collection location from identified places because of practical difficulties. It is found that there could be data loss during measurement and data transmission. During micro SCADA set up we had a problem due to virtual server set up and physical hardware key mismatch. This was due to installed micro SCADA software in the virtual server created at AAU-IT not in any physical server. In contrast to this licence key was hardware key, which has to be plug in to a physical computer server. Due to this mismatch we were unable to get access to RTU data for some time. Later it was solved by new set up with e-licence key, which was generated by ABB.

CHAPTER 6. ROLE OF OBSERVABILITY IN ENHANCED COOPERATION OF ENERGY UTILITIES

This chapter summarizes the manuscripts C6 and B1 that introduces the requirement of interaction of utilities, current scenario and recommendation for way forward. It covers the interface and interoperability of TSO, DSO and Electricity market in the smart grid environment in the emerging scenario. Finally, concept of integrated energy network is also introduced and discussed.

6.1. TSO-DSO INTERFACE IN A SMART GRID ENVIRONMENT

As discussed in chapter 1 section 1.4, the fundamental way of planning and operation of modern electricity network is changing due to the movement toward sustainable energy. This means conventional large power plants at TSO grid are being phased out and penetration of new RE based generators are increasing at DSO grid both at LV as well as MV level. However, still the TSO has the responsibility of overall grid balance and they are loosing ancillary from its own generation and have to rely on new power producers at DSO level. At the same time, costumers/prosumers at DSO grid also want to participate in the electricity market and multiple use of smart meters as well as utilization of demand response program are gaining significant attention. The emerging change in electricity system is represented in Figure 6-1[12], which shows the evolution of new entities (E.g.: BRPs, aggregators etc.) and recession of some of the conventional entities (E.g.: Big generators at TSO grid.). Challenges due to this change in electricity scenario can be categorized as:

- a) Due to the presence of new actors (smart meters, aggregators, retailers, BRP: balance responsible parties etc.) in the system, huge data from the network is available for various applications.
- b) Requirement of the new market framework due to the Commercial interaction of these actors.
- c) Scaled up technical challenges in the grid management due to the fluctuating generations. For example: Congestion, voltage/frequency fluctuation, grid balance, protection/control, islanding etc.

These challenges are for the whole electricity network operation. The work discussed in this chapter focuses on the challenges on operational interaction between TSO-DSO and electricity market considering above-mentioned issues.

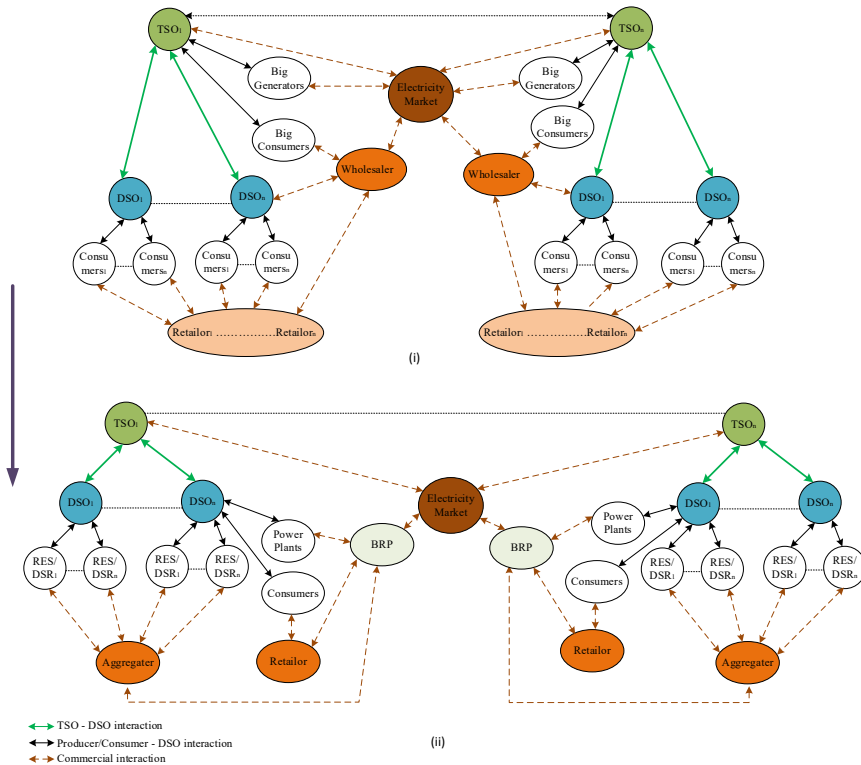

Figure 6-1 Stakeholders interaction in (i) traditional and (ii) emerging scenario

6.1.1. SPECIFIC GRID OPERATION CHALLENGES

Grid operation challenges related to TSO-DSO interaction in emerging scenario are handling of huge data, operation in new market set up and addressing technical challenges like congestion of interfacing transformer and line, voltage support, balancing the grid, islanding etc. These challenges depends on network configuration and operation scenario. Some generic grid operation challenges are but not limited to as listed here [12]:

- a) **Data security and handling:** Data ownership issue, data handling guidelines and costumer’s privacy concern etc. for the huge data that can be made available due to RTU/PMU, smart meter, load/generation forecasting for distributed consumers/prosumers.
- b) **Operation in new market setup:** Level of liberalization in the new market framework to incorporate new participants, information exchange and interaction mechanism, consideration of DSO network limitation in market clearing process etc.

- c) **Congestion of TSO-DSO interfacing transformer and transmission line respectively:** Possibility of overloading of interfacing transformer due to increasing DG/RES/loads at distribution grid and its consequence in transmission line overloading, issue on interfacing transformer ownership and proper communication to the related parties during switching etc.
- d) **Challenges in Power balancing:** Problem in power balancing due to intermittent generation and consumption, flexibility assessment at DSO assets and their participation in ancillary service etc.
- e) **Voltage support on both transmission and distribution network:** Use of each other grid's assets (flexibility on DSO grid, tap setting on interfacing transformer etc.) for voltage support in both grids.
- f) **Interoperability challenges for coordinated protection:** Real time data exchange and interaction for coordinated protection.
- g) **Challenges during Islanding at TSO-DSO interfacing area, re-synchronization and black start:** Provision for regular exercise and type of data exchange to handle network islanding problem.

etc.

6.1.2. CURRENT PRACTICE AND NEW DIMENSION OF TSO-DSO INTERFACE

In this work, general practice in Europe and specific practice in Denmark has been assessed based on literature review, survey and discussions in different project meetings. It is observed that most of the European countries TSO and DSO are sharing specific information (e.g.: operation schedule, forecasted load/generation, grid data, flexibility data etc.) via DEP except in Germany [85] but DEP's ownership and operation is not similar for example in Denmark it is owned and operated by TSO where as in Belgium it is owned by DSO and operated by third party [12]. Market structure is regional and is not country specific. Denmark is participating in Nord Pool electricity market. Because of the inherent characteristics of the market only transmission capacity limitation is considered in the market clearing process. Fluctuating REs generally participate in day ahead market and are based on feed-in-tariff mechanism. Coming down to the technical issue, congestion in interfacing transformer and transmission line are avoided during network planning using n-1 criterion. Generally, TSO is taking care of grid balancing activities without involving DSO but in some cases participation of distribution customer with partial involvement of DSO are observed. For voltage support both TSO and DSO are supporting each other using interfacing transformer tap setting and capacitor bank installed at distribution network. During islanding case, black start is carried out after disconnecting DGs. Practice of coordinated protection is observed to be very limited [12]. Based on this discussion and presented scenario, new dimensions of TSO-DSO interoperability are categorized as:

- i. Non-technical Cluster
 - a. Data handling
 - b. Market framework
 1. Improved traditional framework
 2. Separate market framework
 3. Shared framework for balancing
 4. One flexibility market framework
 5. Combined flexibility market framework
- ii. Technical Cluster
 - a. Network Planning
 - b. System Operation and Control

Detailed description of each cluster is given in [12]. It is recommended to have defined network observability set up for both DSO and TSO with sufficient overlap as shown in Figure 6-2 [12].

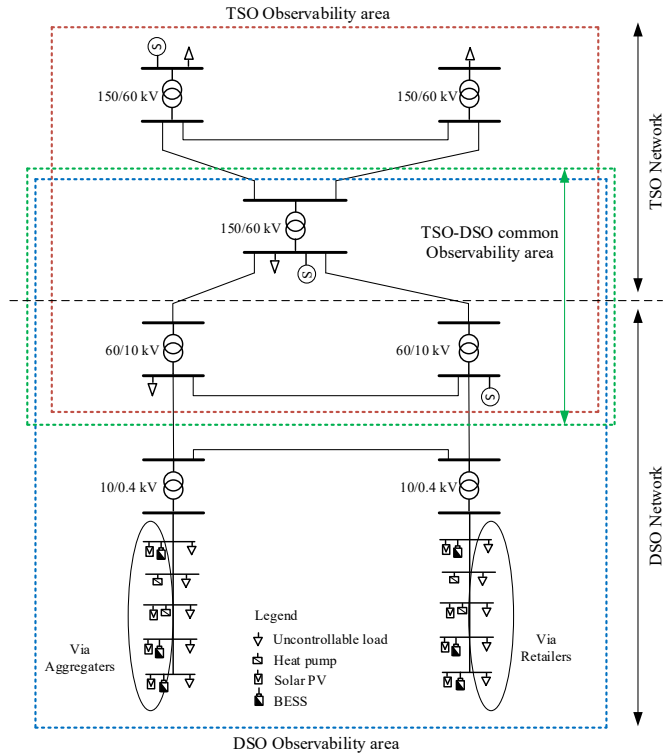

Figure 6-2 Illustration of observability area in a Danish scenario

In common observability area, more intense data exchange is expected (estimated or measured network state, forecasted profile of load and generation etc.) and less data

exchange (e.g.: information about amount of flexibility available at distribution network may be sufficient for TSO) in the area outside the overlapping zone can be sufficient for interaction. For the data, handling the concept of an independent data hub center under the ownership of a public entity is recommended. More liberalized market framework with DSO participation in market clearing process is proposed as a superior option. For technical challenge handling following key technique are highlighted: flexibility prioritization in relation to congestion management, DSO participation (via aggregator) in network balancing, use of reactive power produced from DG for TSO voltage support, exchange of measured and estimated data for quick localization of faults, sharing of DG/RE production forecast for grid restoration etc.

6.2. INTEGRATED ENERGY SYSTEM ARCHITECTURE

Concept of electricity network observability, state estimation and forecasting can also be applicable to other energy system network (e.g.: gas, heating etc.). Interaction of multiple entities in different utilities can be grouped together to form an integrated energy system architecture to observe and monitor the overall system as given in Figure 6-3 [86].

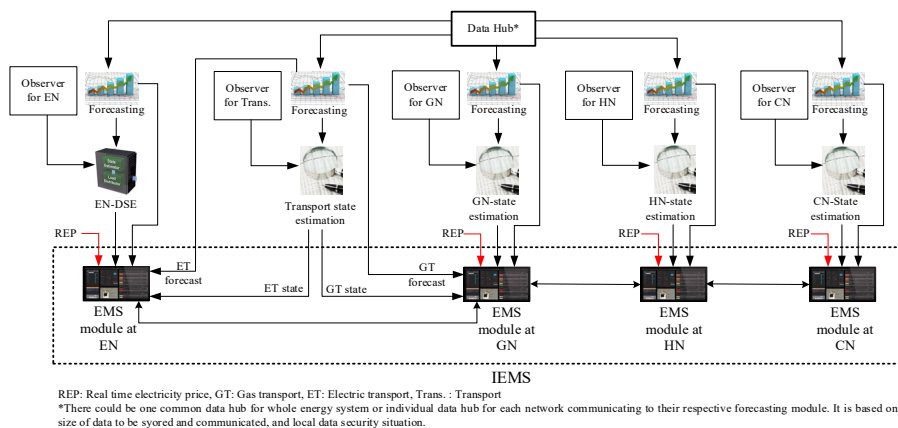

Figure 6-3 Integrated energy system architecture

Here, interface of respective energy management system modules in each network is proposed, which is termed as IEMS. The respective networks can collect minimum measurements from their own network and prepare respective load and supply forecasting as well as estimate the real time network status which is embedded to their own EMS. This information can be exchanged with each other among all EMSs so that an optimum operation strategy can be followed to supply all the energy demand in minimum cost for example if price for gas supply increases, transportation using gas (e.g.: public buses) can be reduced and number of electric vehicle (e.g. Tram) can be increased.

6.3. SUMMARRY

In this chapter, utility interaction specially TSO-DSO interaction are highlighted. Challenges are categorized in three aspects namely huge data handling, new market framework development and addressing of technical challenges in the emerging scenario. Since, conventional big generators at TSO grid are being replaced by RE based generators at DSO grid, challenges are increasing not only in ancillary service management but also in network operation and control. It is presented that with proper strategy and revised framework these challenges can be converted to opportunities in some extent. In the proposed TSO-DSO interaction framework utilization of increased role of DSO is highlighted. Finally, possibility of extension of network observation and monitoring for optimized operation of integrated energy system operation is described briefly with proposed architectural set up.

Over all concluding remark of the thesis and highlight of major contributions will be presented in the following final chapter. It will also illustrate the possible extension for future research.

CHAPTER 7. CONCLUSIONS

This chapter summarizes the overall contributions from the research work carried out during the PhD tenure. It also highlights the possibility for future extension of the project.

7.1. SUMMARY

As highlighted in abstract, this thesis covers five research areas: i) distribution network observability and state estimation, ii) forecasting of electrical load/generation iii) advanced distribution management system for active distribution grid, iv) power loss observation and optimization in active distribution grid v) enhanced cooperation of electricity/energy utilities in smart grid scenario. First two topics are foundation for the assessment of network observability and state estimation in active distribution grids in emerging scenario. Integrated approach to estimate specific parameter from all the buses using minimum real measurements from the field is developed and tested in a real Danish distribution network. Improved short-term load/generation forecasting technique is proposed to use forecasted profiles as pseudo measurements in state estimation when sufficient real measurements are not available. Third topic is about the concept of advanced management system required for emerging active grids. Integrated operation of network measurements and monitoring modules with control modules are discussed and possibility of integrated operation is shown in simulation environment. Application of knowledge of network status in control application for optimized use of network resources is also highlighted. Fourth topic is one of the key module of proposed ADMS configuration, which elaborates the concept of loss optimization that can be applicable in active distribution grid. Last topic is about the assessment of role of improved observability in enhanced cooperation that is essential in emerging scenario. This is discussed mainly focusing on TSO-DSO interoperability and cooperation point of view.

7.2. CONTRIBUTIONS

The PhD study has mainly focused on distribution network observability for state estimation and its application in active distribution grid management in emerging scenario. The main contributions are listed as per below:

1. A simple raw data assessment technique is proposed, which can be embedded in the conventional state estimation procedure to optimize the overall estimation process.
2. Network observability assessment procedure based on numerical approach with added bus prioritization technique is developed. It can be applicable to both LV as well as MV network especially for network measurement and

monitoring. For LV network, it will identify the key measurement data from the pool of huge measurements collected by smart meters. For MV network it can be used to identify the critical location for measuring devices like RTUs, micro PMUs etc.

3. Integrated approach of minimum meter placement, network observability assessment and distribution system state estimation is developed. It can show the trade-off between measurement used, level of network observability and accuracy in estimated states.
4. Improved neural network based load/generation forecasting method considering the most significant factors for specific location (E.g. history of load, holidays, technical as well as social events, environmental factors etc.).
5. Module for advanced distribution management system for the utmost utilization of the resources and optimized operation of active distribution grid. Integrated operation architecture for the network observability, state estimation and monitoring modules and control algorithm for the distribution grid with high penetration of distributed renewable resources.
6. Hybrid power loss optimization mechanism and network reconfiguration strategy for the most economized operation of the network considering the presence of DG, Storage and reconfiguration options.
7. Strategy and framework for the cooperation between utilities specifically between TSO-DSO in the emerging smart grid scenario.
8. Integrated architecture for the optimized operation of multi energy system specifically electricity, gas, heating, cooling and transport system.

7.3. RECOMMENDATIONS FOR THE FUTURE WORKS

This PhD work address and resolve many issues in the network measurement set up, collection and smart application of data in future grid for the network operation and control application. Issues in utility cooperation also have been highlighted. However, these topics (as mentioned in section 7.1) are inherently distinct by nature. So, it should be understood that there is room for improvement and further extension. Possibilities for future investigation are listed as:

1. Although modified NN technique is used for accurate forecasting considering most significant influencing factors. However, it should be equally interesting to see the efficacy of a hybrid model by combining proposed model with established forecasting algorithm.
2. Proposed integrated algorithm is tested using RTU measurements as well as measurements from some conventional meters, which are not time synchronized. So, it should be interesting to identify optimum location of PMUs using proposed method and analyse using time synchronized PMU measurements.
3. Measurement allocation and bus prioritization scheme discussed in this thesis is based on radial feeder set up. However, it may not be true in all

places, ring or mesh feeder set up can also exist. At the same time, physical parameters of the network may not be the same in all the time due to corrosion, ageing, topological changes etc. These issues need further research.

4. Economic analysis and quantification of the profit for the DSO by implementing proposed loss optimization framework might be another interesting area for further research.
5. Lastly, further research in utility interface and cooperation specially operation and planning of multi energy system utilities and common market framework for multi energy trading should be worthy research in emerging scenario. Then proposed module and framework can be scaled up in multidisciplinary research case.

This page intentionally left blank.

REFERENCES

- [1] B. R. Pokhrel, N. Karthikeyan, B. Bak-Jensen, and J. R. Pillai, "Intelligent architecture for enhanced observability for active distribution system," in *2017 IEEE PES Innovative Smart Grid Technologies Conference Europe (ISGT-Europe)*, 2017, pp. 1–6.
- [2] "Energinet.dk - Electricity." [Online]. Available: <http://energinet.dk/EN/ANLAEG-OG-PROJEKTER/Sider/default.aspx>.
- [3] "Transmission system data | Energinet." [Online]. Available: <https://en.energinet.dk/Electricity/Energy-data/System-data>. [Accessed: 11-Apr-2019].
- [4] Z. H. Rather, Z. Chen, and P. Thogersen, "Challenges of Danish power system and their possible solutions," *2012 IEEE Int. Conf. Power Syst. Technol. POWERCON 2012*, 2012.
- [5] "COBRACable: Interconnector to the Netherlands | Energinet." [Online]. Available: <https://en.energinet.dk/Infrastructure-Projects/Projektliste/COBRACable>. [Accessed: 26-Apr-2019].
- [6] L. Kitzing, J. Katz, S. T. Schröder, P. E. Morthorst, and F. Møller Andersen, "The residential electricity sector in Denmark A description of current conditions," DTU, 2016.
- [7] C. Bang, F. Fock, and M. Togeby, "The existing Nordic regulating power market," *Ea Energy Anal.*, pp. 1–32, 2012.
- [8] "Balance responsible parties in Denmark | Energinet." [Online]. Available: <https://en.energinet.dk/Electricity/New-player/Oversigt-over-BA>. [Accessed: 26-Apr-2019].
- [9] Danish Energy Agency 2017, "Overview map of the Danish power infrastructure in 1985 and 2015." [Online]. Available: https://ens.dk/sites/ens.dk/files/Statistik/foer_efter_uk.pdf. [Accessed: 11-Apr-2019].
- [10] D. Connolly, H. Lund, and B. V Mathiesen, "Smart Energy Europe: The technical and economic impact of one potential 100% renewable energy scenario for the European Union," 2016.
- [11] IRENA, "Renewable Energy Prospects for the European Union," 2018.
- [12] B. R. Pokhrel, N. Karthikeyan, B. Bak-Jensen, J. R. Pillai, A. Jensen, K. H. Frederiksen, J. Andreasen, and T. Helth, "Improved TSO - DSO Interoperability and their cooperation in smart grid," in *CIGRE Symposium, Aalborg*, 2019.

- [13] M. Bollen and F. Hassan, *Integration of Distributed Generation in the Power System*. Hoboken, NJ, USA: John Wiley & Sons, Inc., 2011.
- [14] T. Jesper, “Smart Distribution Grids Power Europe’s Transition to Green Energy,” *State of Green*, Denmark, 2017.
- [15] K. Rudion, A. Orths, Z. a. Styczynski, and K. Strunz, “Design of Benchmark of Medium Voltage Distribution Network for Investigation of DG Intrgration,” in *IEEE Power Engineering Society General Meeting*, 2006, pp. 1–6.
- [16] C. Rakpenthai, S. Uatrongjit, and S. Premrudeepreechacharn, “State Estimation of Power System Considering Network Parameter Uncertainty Based on Parametric Interval Linear Systems,” *IEEE Trans. Power Syst.*, vol. 27, no. 1, pp. 305–313, Feb. 2012.
- [17] M. Bockarjova and G. Andersson, “Transmission Line Conductor Temperature Impact on State Estimation Accuracy,” in *2007 IEEE Lausanne Power Tech*, 2007, pp. 701–706.
- [18] A. Primadianto and C. N. Lu, “A Review on Distribution System State Estimation,” *IEEE Trans. Power Syst.*, vol. 32, no. 5, pp. 3875–3883, 2017.
- [19] G. T. Heydt, B. H. Chowdhury, M. L. Crow, D. Haughton, B. D. Kiefer, F. Meng, and B. R. Sathyanarayana, “Pricing and Control in the Next Generation Power Distribution System,” *IEEE Trans. Smart Grid*, vol. 3, no. 2, pp. 907–914, Jun. 2012.
- [20] B. Brinkmann, S. Member, M. Negnevitsky, and S. Member, “A Probabilistic Approach to Observability of Distribution Networks,” *IEEE Trans. Power Syst.*, vol. 32, no. 2, pp. 1169–1178, 2017.
- [21] A. Abur and A. Gómez Expósito, *Power system state estimation : theory and implementation*. Marcel Dekker, 2004.
- [22] S. Bhela, V. Kekatos, and S. Veeramachaneni, “Enhancing observability in distribution grids using smart meter data,” *IEEE Trans. Smart Grid*, vol. 9, no. 6, pp. 5953–5961, 2018.
- [23] R. Gelagaev, P. Vermeyen, J. Vandewalle, and J. Driesen, “Numerical observability analysis of distribution systems,” in *Proceedings of 14th International Conference on Harmonics and Quality of Power - ICHQP 2010*, 2010, pp. 1–6.
- [24] K. Dehghanpour, Z. Wang, J. Wang, Y. Yuan, and F. Bu, “A survey on state estimation techniques and challenges in smart distribution systems,” *IEEE Trans. Smart Grid*, vol. 10, no. 2, pp. 2312–2322, 2019.
- [25] M. E. Baran, “Challenges in state estimation on distribution systems,” in *IEEE Power Engineering Society Summer Meeting*, 2001.

- [26] J. Andreassen, "SCADA / DMS / AMI / NIS: Obsolete?," 2017. [Online]. Available: <http://blogs.esmartssystem.com/scada-dms-ami-nis-obsolete>. [Accessed: 18-Oct-2017].
- [27] B. Gou, A. Abur, and S. Member, "A direct numerical method for observability analysis," *IEEE Trans. Power Syst.*, vol. 15, no. 2, pp. 625–630, 2000.
- [28] E. Castillo, A. J. Conejo, R. E. Pruneda, and C. Solares, "State estimation observability based on the null space of the measurement jacobian matrix," *IEEE Trans. Power Syst.*, vol. 20, no. 3, pp. 1656–1658, 2005.
- [29] E. Castillo, A. J. Conejo, R. E. Pruneda, and C. Solares, "Observability Analysis in State Estimation: A Unified Numerical Approach," *IEEE Trans. Power Syst.*, vol. 21, no. 2, pp. 877–886, 2006.
- [30] G. R. Gray, J. Simmins, G. Rajappan, G. Ravikumar, and S. A. Khaparde, "Making Distribution Automation Work: Smart Data Is Imperative for Growth," *IEEE Power Energy Mag.*, vol. 14, no. 1, pp. 58–67, Jan. 2016.
- [31] D. Della Giustina, M. Pau, P. Pegoraro, F. Ponci, and S. Sulis, "Electrical distribution system state estimation: measurement issues and challenges," *IEEE Instrum. Meas. Mag.*, vol. 17, no. 6, pp. 36–42, Dec. 2014.
- [32] M. E. Baran and a. W. Kelley, "A branch-current-based state estimation method for distribution systems," *IEEE Trans. Power Syst.*, vol. 10, no. 1, pp. 483–491, 1995.
- [33] H. Wang and N. N. Schulz, "A Revised Branch Current-Based Distribution System State Estimation Algorithm and Meter Placement Impact," *IEEE Trans. Power Syst.*, vol. 19, no. 1, pp. 207–213, 2004.
- [34] Y.-F. Huang, S. Werner, J. Huang, N. Kashyap, and V. Gupta, "State Estimation in Electric Power Grids: Meeting New Challenges Presented by the Requirements of the Future Grid," *IEEE Signal Process. Mag.*, vol. 29, no. 5, pp. 33–43, 2012.
- [35] R. A. Jabr, B. C. Pal, and R. Singh, "Choice of estimator for distribution system state estimation," *IET Gener. Transm. Distrib.*, vol. 3, no. 7, pp. 666–678, 2009.
- [36] G. Celli, P. A. Pegoraro, F. Pilo, G. Pisano, and S. Sulis, "DMS Cyber-Physical Simulation for Assessing the Impact of State Estimation and Communication Media in Smart Grid Operation," *IEEE Trans. Power Syst.*, vol. 29, no. 5, pp. 2436–2446, Sep. 2014.
- [37] C. Muscas, M. Pau, P. A. Pegoraro, and S. Sulis, "Effects of Measurements and Pseudomeasurements Correlation in Distribution System State Estimation," *IEEE Trans. Instrum. Meas.*, vol. 63, no. 12, pp. 2813–2823, Dec. 2014.

- [38] M. Pau, P. A. Pegoraro, and S. Sulis, "Performance of three-phase WLS distribution system state estimation approaches," in *2015 IEEE International Workshop on Applied Measurements for Power Systems (AMPS)*, 2015, pp. 1–6.
- [39] Wenwu Li; Binbin Mi; Cuilian Huang; Xiaocui Xiong, "Distribution network state estimation based on node voltage of variable weights," in *2013 5th International Conference on Modelling, Identification and Control (ICMIC)*, 2013.
- [40] C. Muscas, M. Pau, P. A. Pegoraro, S. Sulis, F. Ponci, and A. Monti, "Multiarea Distribution System State Estimation," *IEEE Trans. Instrum. Meas.*, vol. 64, no. 5, pp. 1140–1148, May 2015.
- [41] P. A. Pegoraro and S. Sulis, "Robustness-Oriented Meter Placement for Distribution System State Estimation in Presence of Network Parameter Uncertainty," *IEEE Trans. Instrum. Meas.*, vol. 62, no. 5, pp. 954–962, May 2013.
- [42] J. Liu, F. Ponci, A. Monti, C. Muscas, P. A. Pegoraro, and S. Sulis, "Optimal Meter Placement for Robust Measurement Systems in Active Distribution Grids," *IEEE Trans. Instrum. Meas.*, vol. 63, no. 5, pp. 1096–1105, May 2014.
- [43] R. J. Hyndman and G. Athanasopoulos, *Forecasting: Principles and Practice*, 2nd ed. OTexts: Melbourne, Australia, 2018.
- [44] I. Badran, H. El-Zayyat, and G. Halasa, "Short-Term and Medium-Term Load Forecasting for Jordan's Power System," *Am. J. Appl. Sci.*, vol. 5, no. 7, pp. 763–768, 2008.
- [45] E. A. Feinberg and D. Genethliou, "Load Forecasting," in *Applied Mathematics for Restructured Electric Power Systems: Optimization, Control, and Computational Intelligence*, J. H. Chow, F. F. Wu, and J. Momoh, Eds. Boston, MA: Springer US, 2005, pp. 269–285.
- [46] D. C. Montgomery, C. L. Jennings, and M. Kulahci, *Introduction to time series analysis and forecasting*. Wiley-Interscience, 2008.
- [47] Z. H. Osman, M. L. Awad, and T. K. Mahmoud, "Neural network based approach for short-term load forecasting," in *2009 IEEE/PES Power Systems Conference and Exposition, PSCE 2009*, 2009, pp. 1–8.
- [48] T. M. Peng, N. F. Hubele, and G. G. Karady, "Advancement in the application of neural networks for short-term load forecasting," *IEEE Trans. Power Syst.*, vol. 7, no. 1, pp. 250–257, 1992.
- [49] M. Shahidehpour, H. Yamin, Z. Li, and John Wiley & Sons., *Market operations in electric power systems: forecasting, scheduling, and risk management*. Institute of Electrical and Electronics Engineers, Wiley-Interscience, 2002.

- [50] A. G. Bakirtzls, V. Petridls, S. J. Klartzis, M. C. Alexlads, and A. H. Malssls, "A neural network short term load forecasting model for the Greek power system," *IEEE Trans. Power Syst.*, vol. 11, no. 2, pp. 858–863, May 1996.
- [51] A. D. Papalexopoulos, Shangyou Hao, and Tie-Mao Peng, "An implementation of a neural network based load forecasting model for the EMS," *IEEE Trans. Power Syst.*, vol. 9, no. 4, pp. 1956–1962, 1994.
- [52] J. W. Taylor and R. Buizza, "Neural network load forecasting with weather ensemble predictions," *IEEE Trans. Power Syst.*, vol. 17, no. 3, pp. 626–632, Aug. 2002.
- [53] J. Yokoyama and Hsiao-Dong Chiang, "Short Term Load Forecasting improved by ensemble and its variations," in *2012 IEEE Power and Energy Society General Meeting*, 2012, pp. 1–6.
- [54] H. Quan, D. Srinivasan, and A. Khosravi, "Short-Term Load and Wind Power Forecasting Using Neural Network-Based Prediction Intervals," *IEEE Trans. Neural Networks Learn. Syst.*, vol. 25, no. 2, pp. 303–315, Feb. 2014.
- [55] A. Y. Alanis, "Electricity Prices Forecasting using Artificial Neural Networks," *IEEE Lat. Am. Trans.*, vol. 16, no. 1, pp. 105–111, Jan. 2018.
- [56] "Pearson's Correlation Coefficient - Statistics Solutions." [Online]. Available: <http://www.statisticssolutions.com/pearsons-correlation-coefficient/>. [Accessed: 08-Dec-2017].
- [57] F. Campos, L. Marques, N. Silva, F. Melo, L. Seca, C. Gouveia, A. Madureira, and J. Pereira, "ADMS4LV – advanced distribution management system for active management of LV grids," *CIGRE - Open Access Proc. J.*, vol. 2017, no. 1, pp. 920–923, 2017.
- [58] B. Williams and S. Ao, "Advanced Distribution Management can bridge the chasm on the road to grid modernization," *China Int. Conf. Electr. Distrib. CIGRE*, pp. 1–4, 2012.
- [59] B. P. Hayes and M. Prodanovic, "State Forecasting and Operational Planning for Distribution Network Energy Management Systems," *IEEE Trans. Smart Grid*, vol. 7, no. 2, pp. 1002–1011, 2016.
- [60] M. S. Hossan, B. Chowdhury, J. Schoene, and S. Bahramirad, "Advanced Distribution Management System: Implementation, Assessment, and Challenges," *IEEE Power Energy Soc. Gen. Meet.*, vol. 2018–August, pp. 1–5, 2018.
- [61] A. P. Sakis Meliopoulos, E. Polymeneas, Z. Tan, R. Huang, and D. Zhao, "Advanced distribution management system," *IEEE Trans. Smart Grid*, vol. 4, no. 4, pp. 2109–2117, 2013.
- [62] F. Pilo, G. Pisano, and G. G. Soma, "Advanced DMS to Manage Active

- Distribution Networks,” in *2009 IEEE Bucharest PowerTech*, 2009, pp. 1–8.
- [63] Nordisk Ministerråd and Nordisk Råd, *Coordination of network operations and system responsibility in the Nordic electricity market*. Nordisk Ministerråd, 2006.
- [64] F. Pilo, G. Mauri, and F. S. B. Bak-Jensen, E. Kämpf, J. Taylor, “Control and automation functions at the TSO and DSO interface: impact on network planning,” *CIREN - Open Access Proc. J.*, 2017.
- [65] A. Zegers and H. Brunner, “TSO-DSO interaction: An Overview of current interaction between transmission and distribution system operators and an assessment of their cooperation in Smart Grids,” 2014.
- [66] N. Natale, F. Pilo, G. Pisano, G. G. Soma, M. Coppo, R. Turri, G. Petretto, and M. Cantù, “Assessment of Price and Quantity of Ancillary Services Provided by Active Distribution Systems at the TSO/DSO Interface,” in *CIREN Workshop 2016*, 2016, p. 223 (5 .)-223 (5 .).
- [67] A. Saint-Pierre and P. Mancarella, “Active Distribution System Management: A Dual-Horizon Scheduling Framework for DSO/TSO Interface under Uncertainty,” *IEEE Trans. Smart Grid*, vol. 8, no. 5, pp. 2186–2197, 2017.
- [68] D. A. Sbordone, E. M. Carlini, B. Di Pietra, and M. Devetsikiotis, “The future interaction between virtual aggregator-TSO-DSO to increase DG penetration,” *Proc. - 2015 Int. Conf. Smart Grid Clean Energy Technol. ICSGCE 2015*, pp. 201–205, 2016.
- [69] B. R. Pokhrel, N. Karthikeyan, B. Bak-Jensen, and J. R. Pillai, “Effect of Smart Meter Measurements Data On Distribution State Estimation,” in *Proceedings of 19th IEEE International Conference on Industrial Technology (ICIT)*, 2018, pp. 1207–1212.
- [70] B. R. Pokhrel, N. Karthikeyan, B. Bak-Jensen, J. R. Pillai, S. M. Mazhari, and C. Y. Chung, “An Intelligent Approach to Observability of Distribution Networks,” in *Proceedings of IEEE PES General Meeting, USA*, 2018.
- [71] B. R. Pokhrel, B. Bak-Jensen, and J. R. Pillai, “Integrated Approach for Network Observability and State Estimation in Active Distribution Grid,” *Energies*, vol. 12, no. 12, p. 2230, Jun. 2019.
- [72] N. Karthikeyan, B. R. Pokhrel, J. R. Pillai, B. Bak-Jensen, A. Jensen, T. Helth, J. Andreasen, and K. H. B. Frederiksen, “Coordinated Control with Improved Observability for Network Congestion Management in Medium-Voltage Distribution Grid,” in *Proceedings of CIGRE Session, Paris*, 2018.
- [73] H. S. Hippert, C. E. Pedreira, and R. C. Souza, “Neural networks for short-term load forecasting: a review and evaluation,” *IEEE Trans. Power Syst.*, vol. 16, no. 1, pp. 44–55, 2001.

- [74] N. Karthikeyan, B. R. Pokhrel, J. R. Pillai, and B. Bak-Jensen, "Multi-level control framework for enhanced flexibility of active distribution network," *ISGT NA 2017, Washingt. DC*, 2017.
- [75] B. R. Pokhrel, N. Karthikeyan, B. Bak-Jensen, and J. R. Pillai, "Loss optimization in distribution networks with distributed generation," in *2017 52nd International Universities Power Engineering Conference (UPEC)*, 2017, pp. 1–6.
- [76] IEEE Standards Coordinating Committee 21, "IEEE Guide for Smart Grid Interoperability of Energy Technology and IT Operation with the EPS, End-Use Applications, and Loads," New York, 2011.
- [77] IEEE Power and Energy Society, "IEEE Recommended Practice for Implementing an IEC 61850-Based Substation Communications, Protection, Monitoring, and Control System," 2017.
- [78] "Eniig homepage." [Online]. Available: <https://eniig.dk/privat/el/>. [Accessed: 01-Jul-2019].
- [79] B. Hayes and M. Prodanovic, "A comparison of MV Distribution System State Estimation methods using field data," in *IEEE Power and Energy Society General Meeting*, 2015.
- [80] "RTU520 product line: Intuitive insight for distribution systems | ABB." [Online]. Available: <https://new.abb.com/substation-automation/products/remote-terminal-units/rtu520>. [Accessed: 01-Jul-2019].
- [81] ABB, "Intuitive insight for distribution systems . RTU520 product line .," 2017.
- [82] ABB, "Remote Monitoring , Control and Measurement RTU520 enables automation of your network," 2017.
- [83] ABB, "KEVA 24 C Indoor voltage sensor," 2014.
- [84] ABB, "KECA 80 D85 Indoor current sensor (split core type)," 2015.
- [85] THEMA Consulting Group, "Data Exchange in Electric Power Systems: European State of Play and Perspectives," 2017.
- [86] B. R. Pokhrel, N. Karthikeyan, R. Sinha, B. Bak-Jensen, and J. R. Pillai, "Architecture of integrated energy systems," in *Reliable and sustainable power and energy systems*, Springer.

This page intentionally left blank.

PUBLICATIONS

Publication: C1

(Conference Paper)

Intelligent Architecture for Enhanced Observability for Active Distribution System

Basanta Raj Pokhrel, N. Karthikeyan, Birgitte Bak-Jensen, Jayakrishnan R. Pillai

This paper is published in 2017 IEEE PES Innovative Smart Grid Technologies Conference Europe (ISGT-Europe), 2017, pp. 1–6.

DOI: 10.1109/ISGTEurope.2017.8260186

Intelligent Architecture for Enhanced Observability for Active Distribution System

Basanta Raj Pokhrel, N. Karthikeyan, Birgitte Bak-Jensen, Jayakrishnan R. Pillai,
Department of Energy Technology,
Aalborg University, Denmark
{bap, kan, bbj, jrp}@et.aau.dk

Abstract— The Modern distribution grids are integrated with increasing amount of intermittent and distributed renewable generation sources with new loads and storage elements. These grids operate today with less observability and information of the distribution of the load and generation in real time. To increase hosting capacity and network flexibility, the smart grid thus demands more accurate knowledge of the state of the grid in actual operating time. Therefore, in this paper, scope and evaluation methods for network observability are reviewed and analyzed from the perspective of distribution system operators. Based on a state of the art review, survey and recommendation from distribution system operators, a high-level architecture for an active distribution system is presented. This satisfies the need for higher observability reach with a minimum number of field observations. The fundamental component of this architecture is distribution state estimation. Here, best possible network state is estimated by processing minimum measurements supported by improved load and generation forecasting modules. Functions and calculation techniques of state estimation and load forecasting used to improve the observability are discussed and analyzed. This work, with the help of decisive scenarios, illustrates the applicability of the intelligent architecture for efficient coordination, management and economic operation of active distribution networks.

Index Terms—Active distribution grid, load forecasting, observability, state estimation.

I. INTRODUCTION

The European Union (EU) is on its way to meet a 20% target for renewable energy sources in the total energy consumption by 2020 and significant deployment of electric vehicles by 2050. In Denmark, as part of the renewable energy policies, 50% of electricity production by wind by 2020 and 100% renewable energy by 2050 are targeted [1]. As greater shares of variable production are integrated into the system, electric network operators are facing new challenges in maintaining high efficiency and reliability. The interaction of each stakeholder in the power system thus becomes more prominent and dynamic modelling of the distribution system becomes more important. Due to the large growth of distributed energy resources (DER) and demand response resources (DRR) in the distribution network (DN), the distribution companies have to proactively manage and

control several active assets in their grids. This involves real time monitoring of DN and frequent interactions between distribution system operators (DSO) and several relevant players like customers, retailers, aggregators and DRR owners in their network for grid management and optimization.

At present, real time monitoring of most of the DN is limited to secondary substation only. In future, due to increased complexity in DN (high DRR, demand response etc.), measurements at substation will not reflect the overall operating condition of the grid. To sustain with the increased complexity, one of the key tasks in the future DNs will be achieving and maintaining the observability of the overall network. Then, even in such situation, it can provide reliable inputs to upgrade various functions of the Distribution Management Systems (DMS) such as Volt/Var control, protection, loss minimization etc. This is only possible for the DSO through real-time knowledge of the system state.

Several approaches for real time monitoring of the system using state estimation in transmission networks have been published [2]. These methodologies cannot be directly applied to the distribution systems because of insufficient real time measurement data at medium and low voltage levels and complexity in developing efficient and robust estimation algorithms for multi-phase asymmetric distributions. Traditional transmission system state estimation use node voltage based methods where fast decoupled estimation were used to speed up the calculation [3]. Here the dependencies between active power and voltage magnitude and reactive power and voltage angle have been eliminated. The fast decoupled method normally assumes that line resistances are smaller than line reactance's. It is not valid for distribution networks and cannot be used for decoupling to speed up the distribution state estimator (DSE) [4]. Also, to speed up the calculation, the Jacobian matrix was assumed to be constant during iterations that are not valid for networks with current measurement, which is very common in distribution networks. To solve the problem with the node voltage based method in distribution networks a new branch current based method was introduced in [5]. It is superior to the node voltage based method because it is faster, not affected by the line R/X-ratio, easy to use with current measurements and equations are

This work is a part of "Determination of automation demands for improved controllability and observability in distribution networks" project funded by Energinet.dk through PSO-ForskEL funding

simpler too. This method also efficiently handles power measurements. Its defect in voltage handling capability have been improved in [6]. In [7] the capability to utilize phasor measurement (PMU) was added to the branch current based DSE.

Least square based SE techniques which are being used for a very long time by the Transmission System Operator (TSOs) are used presently in distribution systems [3]. But, as compared to DER penetration the percentage of investments in measurement equipment is much more reduced at distribution level. Only a limited set of measurements in the primary substations and sometimes in secondary substations are available. The equipment is mostly old and the measurements are not synchronized but averaged and collected at different time frame. On the other hand, it will create large computational burden to process all the measured data by each smart meter if installed at every load points in future. So, it will be impossible to use classical SE techniques, as there is no sufficient synchronization, statistical characterization and redundancy of the available information.

However, many approaches tend to use the traditional least square methods by introducing a large number of pseudo-measurements for loads and generators [8]. But in reality, the loads and generators profiles are estimated profiles based on the past yearly energy consumption. This means that there is no statistical information available about them so it is impossible to correctly use them as pseudo-measurements in a least square approach without improved load – generation forecasting technique. Hence, to improve the observability of the distribution system, it is necessary to design an innovative technique and procedure, which will use a minimum number of field measurements and give maximum observability. This approach must be robust and computationally fast, as it should run on-line under a control center that can support the cause of a future enhanced control, protection and operation service in an advanced distribution management system (ADMS) for the DSO [9]. So, the objective of this work is to formulate an intelligent State Estimation (SE) architecture which will use minimum number of measurements from field, that will ensure minimum modification in existing infrastructure realizing reduced investments and improved techno-economic efficiency to integrate more distributed energy resources in their grids. Such an arrangement is one of the main challenges faced by the DSO for planning, operating and control of the highly active distribution grids using the increasing proportions of smart meter measurements and advanced metering infrastructure (AMI) infrastructures. This paper is structured as follows: Observability analysis is discussed in section II and elements of observability is presented in section III. Section IV illustrates the intelligent architecture and its application scenarios and section V concludes the paper.

II. OBSERVABILITY ANALYSIS

The power system is said to be observable if the network state can be estimated uniquely for the given topology and measurements. Effective compensation of measurement errors and localization of bad data can be realized by controlling the measurements and the number of nodes in the network [10].

The observability of the whole network is analyzed by calculating the rank of the measurement Jacobian matrix. If this rank is equal to the number of unknown state variables, then the network is said to be observable. SE can obtain the state vector of the whole system. The rank of the measurement Jacobian matrix is dependent on the locations and types of available measurements as well as on the network topology.

Considering the linearized measurement model as in equation (1) [4],

$$\Delta z = H\Delta x + e \quad (1)$$

Where, e is noise with error covariance matrix R , z is the measurement vector and x is the state variables vector. Estimated $\Delta \hat{x}$ using weighted least square (WLS) algorithm will be given by equation (2).

$$\Delta \hat{x} = (H^T R^{-1} H)^{-1} H^T R^{-1} \Delta z \quad (2)$$

If $(H^T R^{-1} H)$ is non-singular, a unique solution for Δx can be calculated. It means that the measurement Jacobian matrix (H) has full column rank, i.e. $\text{rank}[H] = n$ (total number of states). The active power (P) - voltage (V) and reactive power (Q) - phase angle (θ) observability can be separately tested using the weak coupling between them. The linearized model can be decoupled as per equations (3) and (4) for separate observability test for power system parameters $P - V$ and $Q - \theta$.

$$\Delta z_A = H_{AA} \Delta \theta + e_A \quad (3)$$

$$\Delta z_R = H_{RR} \Delta \theta + e_R \quad (4)$$

Brief theoretical insight given in equation (1)-(4) for observability calculation has to be supported by an evaluation technique (E.g.: probabilistic observability assessment [11]) to identify the use of less number of meters. Then higher degree of observability can be achieved with minimum cost. But, in a three phase formulation, the rank may also be affected by the coupling terms between phases. In certain cases, one phase may be observable while the others are not. Thus, the relationship between numerical observability and topological observability is not obvious under these conditions. Therefore it may not be straight forward to define the topological observability for a three-phase SE formulation [12]. As explained in [12], the numerical observability analysis based on triangular factorization of the gain matrix can be applied to the three-phase SE without major modifications. If any zero pivot is encountered during the factorization of the gain matrix, the corresponding state variable is not observable. In the three-phase formulation, the zero pivot may correspond to one specific phase of a bus.

Once the distribution network is identified as observable, a hierarchical control can significantly boost the economic operation of prosumers and flexible loads connected to it and the TSO too. Interlinks of different observability elements and their applicability in an advanced distribution system are explained later in section IV.

III. ELEMENTS OF IMPROVED OBSERVABILITY

Due to insufficient knowledge of load/generation distribution in their networks, especially in real time

distribution grids still operate with reduced observability. This can be improved by collecting data from strategic locations in the grid, load forecasting and state estimation. These are the key elements of improved observability. Fig. 1 illustrates a setup of enhanced observability used for improved control. Load/generation forecasted profiles are inputs for both Hierarchical Control (HC) and DSE. Based on the feedback received from the HC element, the DSE will give an estimated state to the HC module for improved control, protection and reconfiguration. The loss observation and minimization module will identify the section of the network with high loss and give information for minimization to the ADMS, which will coordinate the other modules. Improved interaction between TSO and DSO to provide ancillary service, manage network congestion and system reserves will be realized through the proposed TSO – DSO interface. This will get input from ADMS. In the following section, the individual blocks of Fig. 1 will be described further.

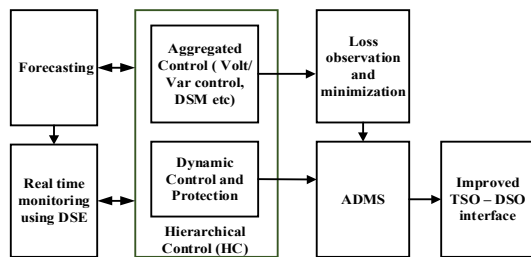

Fig. 1 Structure where enhanced observability and state estimation are used for improved control

A. Distribution state estimation

DSE is a mathematical analysis tool. Like a noise filter, it eliminates errors in data and estimates the system states in advance which can be used for control, protection and system operation. To use real time measurements for enhanced grid observability at distribution level a new modern state estimator is needed. It should have a verified track record, be easy to implement and computationally efficient and robust. In literature several methods like probabilistic approach, fuzzy logic, hybrid particle swarm optimization, interior point optimization for DSE have been found which are tested in standard networks. Weighted least squares (WLS) is applied in several studies. Though the branch current based WLS method is specially designed for distribution networks methods based either on node voltage or branch current can be chosen for improved observability and applied to MV and LV networks. For SE, network topology, network configuration, line parameters, and load profiles are expected to be given.

Layout of a DSE assessment method for enhanced network observability is shown in Fig. 2. Observability analysis of data and network can be carried out systematically to get improved knowledge about system states [13]. Different sets of data will be analyzed and if found not solvable while applying the optimization problem then the percentage of pseudo measurements will be increased and tested again. The more pseudo measurements are used the more inaccuracy in estimated states will be achieved. So, a separate meter placement optimization algorithm will be initiated to identify the optimum number of meters and their location in the

network to be considered for the analysis. If one set of variables (normally bus voltage) are known, then every other quantity about the system can be calculated from them. A bad data identification loop will detect the bad data using chi-squares test and eliminate them before receiving the network state. Network observability analysis will give confirmed network states by comparing the rank of the measurement Jacobian matrix with the number of unknown state variables. It is said to be observable if they are equal i.e. it is possible to determine the behavior of the entire system with estimated states. This observability will be considered as enhanced if it is achieved with less computer burden and this depends on the accuracy of the load forecasting module and number of meters used which are a key input for the DSE.

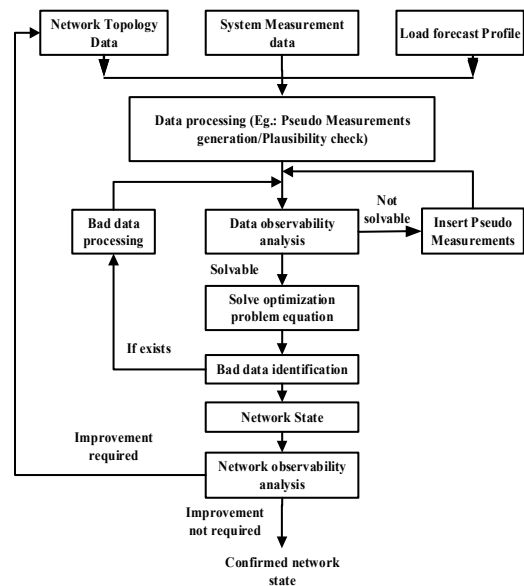

Fig. 2 Graphical overview of the power system state estimation procedure for enhanced observability

B. Load forecasting

Forecasting is considered as a stochastic problem rather than deterministic. Due to this stochastic nature none of the forecasting variables are 100% accurate. Bad data, inappropriate methodologies, and weak tools will boost the inaccuracy of forecasting. So, the accuracy of forecast can always be improved. Future load and generation data are essential inputs for distribution state estimation. This data can be generated by using historic data from strategically placed meters and applying forecasting techniques. Based on different lead time, load forecasting can be divided in to three categories short term, mid-term and long term [14]. Results of short term forecasting are used in short term operation planning e.g. generation dispatching because this forecasting predicts the hourly load demand of the periods. A number of forecasting methods can be found in literature. A simplified short term load forecasting method based on sequential patterns is presented in [15]. In this algorithm the continuous data are discretized in order to compare recent to past patterns so some errors due to discretization are introduced. A new approach for forecasting functional time series has been proposed in [16]. Though this household-level electricity demand forecasting represents a key factor to assure the

balance supply/demand in the LV network; it can be improved by using some daily random variables (internal/external temperature and sunshine curves) and discrete variables (number of electric appliances). K-nearest neighbor based model for day ahead load forecasting is proposed in [17]. This requires only minimum and maximum temperature as a forecasting input.

To obtain pseudo measurements, parametric or non-parametric short term forecasting techniques and for load modelling, non-intrusive load identification techniques can be used [16]. Transformer tap settings and switching/re-closer device settings have to be considered apart from the typical primary (voltage and phase angles) and secondary (currents and power flow) state variables to increase the accuracy of the forecasted load profile. A DSE with forecasting module is illustrated in Fig. 3.

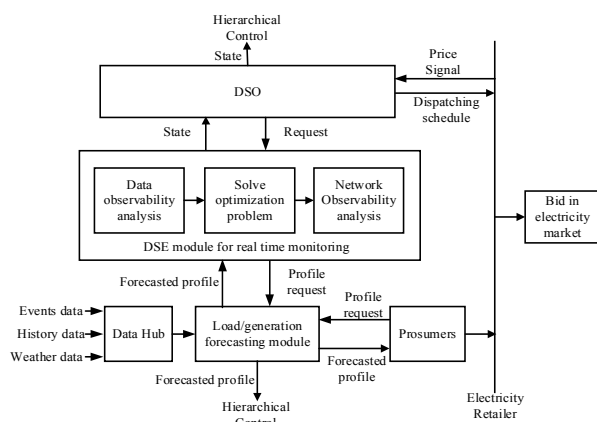

Fig. 3 DSE with forecasting module

It is aimed to consider social events (example: Christmas, New Year, Tournament etc.) and technical events (example: maintenance scheduling) together with load/generation history data and weather forecasting to improve the accuracy of a short term load forecasting module. An ARIMA model can be modified and used to incorporate this extension in forecasting [18], [19]. Due to the improved load forecasting, the SE performance will be upgraded and the accuracy of the model predictive control block of the hierarchical control (for enhanced controllability in ADG) will be improved. Also, DSO and prosumers can interact with the electricity market more precisely for flexibility trading and demand response respectively. It means reach of observability limit will be upgraded.

C. Hierarchical control

In a hierarchical control, there are often three levels of control: direct control (equipment level), supervisory control and decisive control [20]. Modules in the supervisory control such as Volt/Var control, DSM, fault location identification and service restoration (FLISR) will be integrated to the observability modules. Due to enhanced observability, this module can generate corrective action to individual equipment and optimize the utilization of network assets.

D. Loss observation and minimization

Technical loss is mainly due to power system components and mode of operation. Due to $R > X$, high currents and more transformer power losses, the percentage of power loss at distribution level is relatively more than at transmission level. The power loss of networks below 10 kV is up to 60% of the total loss[21]. So, loss observation and optimization in distribution systems is essential for economic and efficient operation which can be observed using DSE and minimized using reconfiguration and coordination strategies [22].

E. Active distribution grid management system (ADMS)

ADMS is a software platform for interoperability check that can also perform integrated analysis of energy efficiency, demand response and distributed generation (DG)[23]. Interconnection of observability and controllability modules, standard verification and system integration will be the design approach for ADMS. As a result, the utility operator can take intelligent decisions as per the received real time data in the system.

F. Improved TSO-DSO interface

Due to the increased number of DG, flexible load and demand response there is a need to have higher observability at distribution level. It should be accessible by the TSO too. Short term events at low and medium voltage level can be addressed and thereby the TSO can improve the controllability and guarantee a reliable supply. The extent of information exchange needed will be identified. It can be realized by security assessment and using a virtual aggregator [24].

IV. INTELLIGENT ARCHITECTURE

The observability analysis procedures, DSE structure and its link with observability and market component for active distribution grids presented in the Fig. 1, Fig. 2, and Fig. 3 can be integrated to form an intelligent control architecture. This architecture is shown in Fig. 4. Here, power generation, transmission and distribution infrastructure are considered as the power system or the physical layer. All observations and control entities with market components are grouped as an observability cluster. The power system network is divided in three layers: low voltage (LV), medium voltage (MV) and high voltage (HV). DERs that are connected to LV are referred to as μ DER and consumers having generation are also grouped as prosumers. The data hub is a data bank which can have access to customer meters and store not only load data but also metrological forecasts, social events, technical events etc. which will be required for the forecasting and the DSE module. A load forecast algorithm will first initiate, prepare forecast profiles, and pass them to the DSE. Prosumers can also use the forecasted load profile to calculate electricity bids and participate in the electricity market via aggregators (collectively bid in the market on behalf of a group of μ DER).

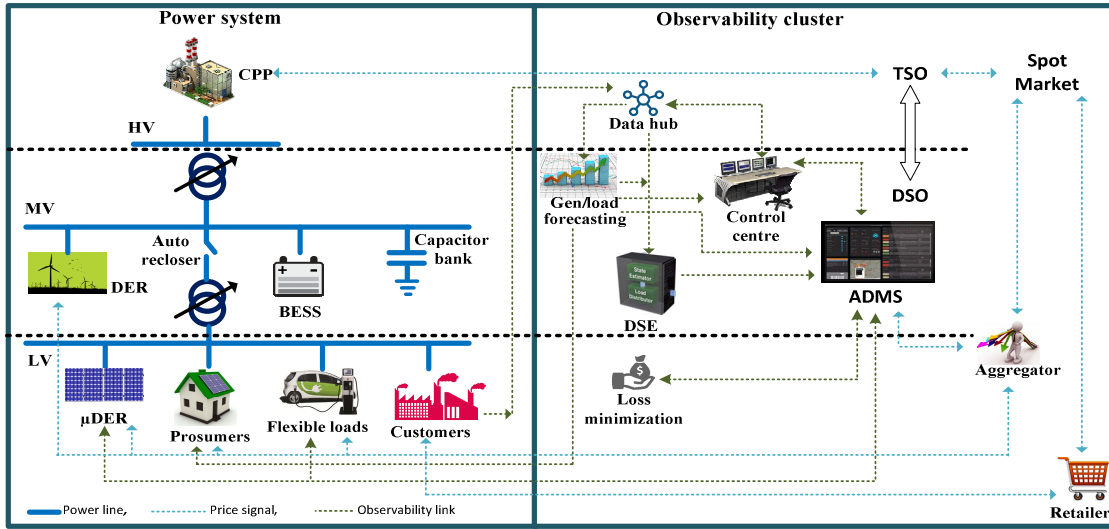

Fig. 4 Intelligent control architecture based on observable system with SE

System states are the key observability indices, which are the output of the DSE algorithm that are finally furnished to control modules via ADMS. The network model will be updated continuously and state estimation as well as load flow will be evaluated for each updated network. It will also handle new applications such as bidirectional power flows, multilevel control, adaptive protection and market interface. The interaction can be verified using standard communication protocols (IEC 61850, IEC TC57, IEC 61968) [23]. Based on the observed network state and configuration a loss optimization module will be initiated. Input received from Volt/Var control, DSM, Intelligent reconfiguration and Energy storage via ADMS will be redefined as variables, optimal power flow (OPF) constraints and optimality conditions and loss optimization can be formulated as an objective function. Optimized network configuration and settings after solving this optimization problem will be forwarded to the DSO via ADMS. This information will be used by the DSO to reconfigure the network for economic operation (with respect to loss minimization).

As shown in Fig. 4 grid configuration and load data as well as flexibility status will be the input for the TSO – DSO interface. Flexibility can be allocated and communicated as per the standards via market. It is interlinked with market for system balancing and congestion management. The market layer communicates with TSO and DSO for proper allocation of ancillary service (flexibility, power balance, voltage support). The time frames of the control functions are dispatched for the possible curtailment / activation of DER to DER via aggregator.

A. Application scenarios for intelligent architecture

Here, in this sub-section application scenarios for the intelligent architecture will be briefly illustrated to show the usefulness of the network observability in the real world. The formulated architecture can be simulated and tested based on the targeted applications. Some of the observability element's function discussed above are summarized in the first column of the TABLE 1. Application of each observability element is presented in column three and some methods in two. Fourth column shows the probable beneficiaries. The DSO can use the forecasted load profile for their network reconfiguration, voltage control and prepare a dispatching schedule.

TABLE 1 OBSERVABILITY ELEMENTS AND THEIR APPLICATION

Observability elements	Methodology	Application	Benefiter
Future load/generation profile	Modified Autoregressive models [18], [19]	DSO - dispatching schedule, network reconfiguration, voltage control Prosumers - bid in electricity market via electricity retailer	DSO, Prosumer
Real time supervision of the distribution network	Improved WLS [4] - [13]	DSO - plan for short term situation, input for hierarchical control	DSO
Loss observation and optimization	Reconfiguration and coordination strategy [22]	DSO - economic operation	DSO
Active distribution grid management system (ADMS)	Integrated analysis and verification [25]	DSO - interoperability check, performance check for DSE	DSO, TSO
Improved TSO – DSO interaction and market interface	Security assessment and application of aggregator [24]	TSO and DSO - Ancillary service, Congestion management	DSO, TSO, Prosumer

They can plan for short term situations using the state estimation module. The loss optimization module can boost the economic operation in the distribution system by identifying the optimum solution considering network reconfiguration, DG sizing, and DG allocation etc. Prosumers can use the forecasted load profile to prepare their bid and offer it in the electricity market via an electricity retailer. The concept of ADMS is aimed for the interoperability check of the different modules. The improved TSO – DSO interface module can identify the requirement of information exchange between them for ancillary service and congestion management. Observability clusters are mostly targeted for the DSO, so they are seen as leading beneficiaries of the enhanced observability in the future distribution network.

V. CONCLUSIONS AND FUTURE WORKS

In this paper, scope and application of distribution system observability was investigated. Based on the state of the art review it is shown that improved load forecasting and robust state estimation can be used to enhance the observability in the active distribution network. An intelligent architecture has been formulated. This architecture uses forecasted load and generation profiles as pseudo measurements and a minimum number of real measurements from the field for state estimation calculations. The visibility of each player is

enhanced which leads to more reachability helping electricity trading and network optimization. Some application scenarios are also presented to illustrate this. Future work will focus on the modelling for each observability elements (load forecasting, loss optimization, state estimation etc.) followed by simulation and applicability test of the composite model for the illustrated observability scenarios and application in the real network.

ACKNOWLEDGMENT

The authors gratefully acknowledge the contributions of Energinet.dk, ABB, Eniig, Syd Energi and Kenergy for their inputs during different project meetings.

REFERENCES

- [1] E. and B. Danish Ministry of Climate, "Smart Grid Strategy," vol. 5, no. May, pp. 31–33, 2013.
- [2] Huang et.al, "State Estimation in Electric Power Grids: Meeting New Challenges Presented by the Requirements of the Future Grid," *IEEE Signal Process. Mag.*, vol. 29, no. 5, pp. 33–43, 2012.
- [3] A. Mutanen, A. Koto, and A. Kulmala, "Development and Testing of a Branch Current Based Distribution System State Estimator," in *International Universities' Power Engineering Conference*, 2011, no. September.
- [4] A. Abur and A. Exposito, *Power system state estimation: theory and implementation*. 2004.
- [5] M. E. Baran and a. W. Kelley, "A branch-current-based state estimation method for distribution systems," *IEEE Trans. Power Syst.*, vol. 10, no. 1, pp. 483–491, 1995.
- [6] H. Wang and N. N. Schulz, "A Revised Branch Current-Based Distribution System State Estimation Algorithm and Meter Placement Impact," *IEEE Trans. Power Syst.*, vol. 19, no. 1, pp. 207–213, 2004.
- [7] M. Pau, P. A. Pegoraro, and S. Sulis, "Efficient branch-current-based distribution system state estimation including synchronized measurements," *IEEE Trans. Instrum. Meas.*, vol. 62, no. 9, pp. 2419–2429, 2013.
- [8] Bovo et al., "Improvement of observability in poorly measured distribution networks," in *Power Systems Computation Conference*, 2014.
- [9] A. P. and C.-N. Lu, "A Review on Distribution System State Estimation," *IEEE Trans. Power Syst.*, vol. PP, no. 99, pp. 1–1, 2016.
- [10] D. Waeresch, R. Brandalik, W. H. Wellssow, J. Jordan, R. Bischler, and N. Schneider, "Linear state estimation in low voltage grids based on smart meter data," in *IEEE PowerTech, Eindhoven*, 2015.
- [11] B. Brinkmann, S. Member, M. Negnevitsky, and S. Member, "A Probabilistic Approach to Observability of Distribution Networks," *IEEE Trans. Power Syst.*, vol. 32, no. 2, pp. 1169–1178, 2017.
- [12] C. N. Lu, J. H. Teng, and W. H. E. Liu, "Distribution system state estimation," *IEEE Trans. Power Syst.*, vol. 10, no. 1, pp. 229–240, 1995.
- [13] Wellssow et al., "Linear State Estimation in Low Voltage Grids Based on Smart Meter Data," in *CIGRE*, 2016, vol. C6-111.
- [14] Kampezidou et al., "Distribution Transformers Short-Term Load Forecasting Models," in *Power and Energy Society General Meeting, Boston*, 2016, pp. 1–5.
- [15] Kouzelis et al., "A simplified short term load forecasting method based on sequential patterns," in *IEEE PES Innovative Smart Grid Technologies Europe*, 2014, pp. 1–5.
- [16] M. Chaouch, "Clustering-based improvement of nonparametric functional time series forecasting: Application to intra-day household-level load curves," *IEEE Trans. Smart Grid*, vol. 5, no. 1, pp. 411–419, 2014.
- [17] Zhang et al., "A Composite k -Nearest Neighbor Model for Day-Ahead Load Forecasting with Limited Temperature Forecasts," in *Power and Energy Society General Meeting, Boston*, 2016, pp. 1–5.
- [18] N. Amjady, "Short-term hourly load forecasting using time-series modeling with peak load estimation capability," *IEEE Trans. Power Syst.*, vol. 16, no. 4, pp. 798–805, 2001.
- [19] Kouzelis et al., "Estimation of Residential Heat Pump Consumption for Flexibility Market Applications," *IEEE Trans. Smart Grid*, vol. 6, no. 4, pp. 1852–1864, 2015.
- [20] X. Su, M. A. S. Masoum, and P. J. Wolfs, "Multi-Objective Hierarchical Control of Unbalanced Distribution Networks to Accommodate More Renewable Connections in the Smart Grid Era," *IEEE Trans. Power Syst.*, vol. 31, no. 5, pp. 3924–3936, 2016.
- [21] Junxia et al., "Study on Power Loss of Distribution Network with Distributed Generation and its Reactive Power Optimization Problem," in *International Conference on Power System Technology*, 2014, no. 648, pp. 20–22.
- [22] Morten et al., "Loss Minimization and Voltage Control in Smart Distribution Grid," in *IFAC Proceedings Volumes*, 2014, vol. 47, no. 3, pp. 4030–4037.
- [23] IEEE Standards Coordinating Committee 21, "IEEE Guide for Smart Grid Interoperability of Energy Technology and IT Operation with the EPS, End-Use Applications, and Loads," New York, 2011.
- [24] Danilo et al., "The future interaction between virtual aggregator-TSO-DSO to increase DG penetration," in *International Conference on Smart Grid and Clean Energy Technologies*, 2015.
- [25] "IEC Smart grid: Core IEC Standards." [Online]. Available: <http://www.iec.ch/smartgrid/standards/>.

Publication: C2

(Conference Paper)

Loss optimization in distribution networks with distributed generation

Basanta Raj Pokhrel, N. Karthikeyan, Birgitte Bak-Jensen, Jayakrishnan R. Pillai

This paper is published in 52nd International Universities Power Engineering Conference (UPEC). IEEE Press, 2017.

DOI: 10.1109/UPEC.2017.8232015

Loss optimization in distribution networks with distributed generation

Basanta Raj Pokhrel, N. Karthikeyan, Birgitte Bak-Jensen, *Senior Member, IEEE*,
Jayakrishnan R. Pillai, *Senior Member, IEEE*,
Department of Energy Technology,
Aalborg University, Denmark
{bap, kan, bbj, jrp}@et.aau.dk

Abstract— This paper presents a novel power loss minimization approach in distribution grids considering network reconfiguration, distributed generation and storage installation. Identification of optimum configuration in such scenario is one of the main challenges faced by distribution system operators in highly active distribution grids. This issue is tackled by formulating a hybrid loss optimization problem and solved using the Interior Point Method. Sensitivity analysis is used to identify the optimum location of storage units. Different scenarios of reconfiguration, storage and distributed generation penetration are created to test the proposed algorithm. It is tested in a benchmark medium voltage network to show the effectiveness and performance of the algorithm. Results obtained are found to be encouraging for radial distribution system. It shows that we can reduce the power loss by more than 30% using this method, which is more than 6% as seen in conventional method for used network.

Index Terms— Power loss, Distributed generation, Optimization, Smart distribution system.

NOMENCLATURE

P_{Lk}	Real power load at bus k
Q_{Lk}	Reactive power load at bus k
P_k	Real power flowing out of bus k
Q_k	Reactive power flowing out of bus k
V_k	Voltage at node k
P_{Lk+1}	Real power load at bus k+1
Q_{Lk+1}	Reactive power load at bus k+1
P_{k+1}	Real power flowing out of bus k+1
Q_{k+1}	Reactive power flowing out of bus k+1
V_{k+1}	Voltage at node k+1
$P_{loss, (k, k+1)}$	Active power loss in line section (k, k+1)
$Q_{loss, (k, k+1)}$	Reactive power loss in line section (k, k+1)
R	Resistance of the section of the line
Y	Admittance of the section of the line
P'_k	Real power flowing out of bus k after reconfiguration
Q'_k	Reactive power flowing out of bus k after reconfiguration

V'_k	Voltage at node k after reconfiguration
G	Conductance of the line
B	Susceptance of the line
g	distance of DG location from source
l	Total length of the feeder from source to load
P''_k	Real power flowing out of bus k when DGs are considered
Q''_k	Reactive power flowing out of bus k when DGs are considered
V''_k	Voltage at node k when DGs are considered
$\Delta P''_k$	Change in active power at node k when storage is connected
$\Delta Q''_k$	Change in reactive power at node k when storage is connected
P'''_k	Real power flowing out of bus k when storage system is connected
Q'''_k	Reactive power flowing out of bus k when storage system is connected
$P_{n,eff}$	Total effective power supplied beyond bus n
$Q_{n,eff}$	Total effective power supplied beyond bus n
P_{set}	Power loss set point i.e. unescapable power loss in the network
T	Transformer tap position
$I_{k,k+1}$	Current flowing in line section (k, k+1)
P_{Gk}	Total generation at bus k

I. INTRODUCTION

Distribution networks with renewable energy based generators and demand response resources (DRR) can optimize the economic operation of the network grid using accurate loss optimization modules. This is because a high penetration of distributed resources has significant impact on power loss and voltage distribution due to reverse power flow in the grid. This is even more prominent in distribution networks due to the intermittent nature of renewable resources, DRR and loads connected to it. Loss reduction is now a common goal for power utilities because reduction of active power loss saves both generating cost and creates higher generating reserves. It is also a good indicator for capacity increment and better

This work is a part of “Determination of automation demands for improved controllability and observability in distribution networks” project funded by Energinet.dk through PSO-ForskEL funding

utilization of the existing grid. Minimization of power loss in the distribution network is possible by connecting utility owned storage system (E.g. : Battery energy storage system (BESS)) and network reconfiguration considering installed distributed generation (DG). In order to techno-economically utilize BESS, distribution system operators (DSO) can also use it to relieve voltage problems (specially with high DG penetration), demand response and demand side management functions (valley filling, peak shifting etc.) and other power quality issues. Nowadays, it is also possible to sell flexibility in the market too. Analysis of these utilization options of BESS are out of scope in this study, we are mostly focusing on loss minimization option here.

In distribution grid, DG and BESS have a vital role to maintain the power quality within the limit. Proper allocation will improve power quality and minimize losses but inappropriate allocation will create adverse impact [1], [2]. This impact will be magnified if network configuration is not considered. In this context, several works have been done related to optimal planning of ESS, DG and network reconfiguration for loss minimization. A multi objective procedure is proposed in [3] for optimal siting and sizing of distributed storage units. Here, the impact of network configuration is not considered. In [4], a meta heuristic harmony search algorithm is presented for loss minimization considering reconfiguration and DG but storage system allocation is not considered. Strategy to minimize the loss and voltage control in smart distribution grid considering maximum penetration of electric vehicle and solar panels is presented in [5], but application of storage system is not discussed. Therefore, the focus of this paper is to set up an optimization procedure, which take reconfiguration as well as installed DG and storage placement in to account for loss minimization.

Active network loss can be expressed either by summation of active nodal power over all nodes or by summation of branch losses of all branches [6]. Losses are computed over branches in this research because it allows to formulate loss for a part of a network, which is helpful to incorporate network reconfiguration analysis effectively. Also, it will be possible for each utility to optimize and control its own area without disturbing its neighbor grid operation. Taking minimal loss as an optimal goal an objective function is constructed which is used to optimize the network reconfiguration and placement of storage units considering the penetration of installed DG. Optimization requests from DSO are processed by solving optimum power flow (OPF). This OPF problem is solved by Interior Point Method due to its reliability, speed and accuracy. It also provides user interaction in the selection of constraints [7]. The Interior Point Method can solve a large scale linear programming problem by moving through the interior, rather than the boundary as in the simplex method, of the feasible region to find an optimal solution. In this work, voltage limits, DG power factor, transformer tap position, active, reactive and apparent power limits are considered as optimization constraints. The algorithm performance and its effect on the power loss minimization is observed by formulating different study cases and scenarios by varying storage unit location, network configuration and DG penetration. The medium voltage (MV) CIGRE benchmark network is used for

simulation and analysis. Finally, a loss optimization strategy in the smart distribution network is recommended for DSOs. Optimized network configuration and settings can be used by the DSO to reconfigure the network for economic operation (with respect to loss minimization). This paper is structured as follows: the loss optimization approach and its methodology is discussed in section II and case study details with simulation scenarios are presented in section III. Section IV illustrates the results with discussions and section V concludes the paper.

II. METHODOLOGY

A. Loss optimization problem formulation

Following set of simplified equations [8] are derived from the single-line diagram shown in Fig. 1. These equations represents the power flow in a distribution system without considering DG and BESS in the beginning. These will be discussed later. In this radial feeder, line is represented by ‘ Π ’ model. Switch S1 is closed and S2 is open in normal operating condition.

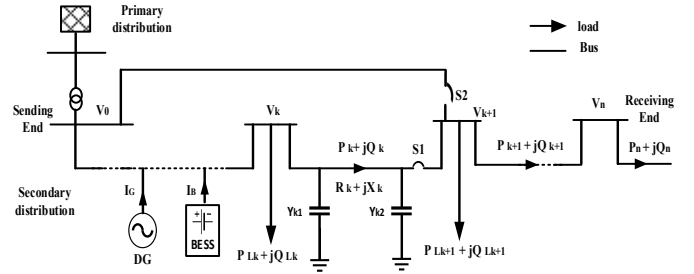

Fig. 1 Single line diagram of distribution system with DG and BESS installation at arbitrary location

$$P_{k+1} = P_k - P_{Loss,k} - P_{Lk+1}$$

$$P_{k+1} = P_k - \frac{R_k}{|V_k|^2} \{P_k^2 + (Q_k + Y_k |V_k|^2)^2\} - P_{Lk+1} \quad (1)$$

$$Q_{k+1} = Q_k - Q_{Loss,k} - Q_{Lk+1}$$

$$Q_{k+1} = Q_k - \frac{X_k}{|V_k|^2} \{P_k^2 + (Q_k + Y_{k1} |V_k|^2)^2\} - Y_{k1} |V_k|^2 - Y_{k2} |V_{k+1}|^2 - Q_{Lk+1} \quad (2)$$

$$|V_{k+1}|^2 = |V_k|^2 + \frac{R_k + X_k^2}{|V_k|^2} \{P_k^2 + (Q_k + Y_k |V_k|^2)^2\} - 2\{R_k P_k + X_k (Q_k + Y_k |V_k|^2)\} \quad (3)$$

Power loss of the branch connecting ‘k’ and ‘k+1’ can be computed as:

$$P_{Loss(k,k+1)} = R_k \cdot \frac{(P_k^2 + Q_k^2)}{|V_k|^2} \quad (4)$$

The total power loss of the feeder, $P_{T,Loss}$, may then be determined by summing up the losses of all line sections of the feeder, which is given as:

$$P_{T,Loss} = \sum_{k=1}^n P_{Loss(k,k+1)} \quad (5)$$

Power loss can be optimize considering:

- Network reconfiguration

- Varying the penetration of installed DG
- Varying the location of storage system

1) Network reconfiguration

In distribution system, this can be used to find the best configuration of the distribution network, which gives minimum power loss. With the help of switches (E.g. S1 and S2), feeder switching or rerouting of power can be done by maintaining the radial nature of the network, which is termed as network reconfiguration. After line reconfiguration, power loss ($P'_{Loss(k,k+1)}$) between line 'k' and 'k+1' can be calculated as:

$$P'_{Loss(k,k+1)} = R_k \cdot \frac{(P'_k{}^2 + Q'_k{}^2)}{|V'_k|^2} \quad (6)$$

Then total power loss of the feeder P'_Tloss , may then be determined by summing up the losses of all line sections of the feeder, which is given as:

$$P'_Tloss = \sum_{k=1}^n P'_{Loss(k,k+1)}$$

2) Varying the penetration of installed DG

Proper penetration of DG in the distribution system have many benefits such as reduction of power loss, voltage profile improvement, peak demand saving etc. When a DG is placed in any arbitrary point in the network given Fig. 1 power loss is quantified as $P_{DG,Loss,a}$ [4]:

$$P_{DG,Loss,a} = \frac{R_k}{V_k^2} \cdot (P_k^2 + Q_k^2) + \frac{R_k}{V_k^2} \cdot (P_G^2 + Q_G^2 - 2P_k P_G - 2Q_k Q_G) \left(\frac{g}{l}\right) \quad (7)$$

But for maximum renewable penetration, if DG are considered to be connected at each customer point (Eg.: Solar PV installed at each customer house), power loss in the distribution network can be computed using net power injection at each bus. Equation (8) can be used to calculate power loss ($P_{DG,Loss}$) in this situation which is derived by neglecting the DG location in equation (7).

$$P_{DG,Loss} = \frac{R_k}{V_k'^2} \cdot (P_k''^2 + Q_k''^2) \quad (8)$$

3) Varying the location of storage system

Optimum placement of storage system (Eg.: DSO owned battery energy storage system (BESS)) can minimize the distribution system losses and optimize the network. Power loss in distribution system considering storage at arbitrary point ($P_{Storage,Loss}$) is given by:

$$P_{Storage,Loss} = \sum_{k=1}^n [\alpha_{k,k+1} (P_k P_{k+1} + Q_k Q_{k+1}) + \beta_{k,k+1} (Q_k P_{k+1} - P_k Q_{k+1})] \quad (9)$$

where,

$$\alpha_{k,k+1} \triangleq \frac{R_{k,k+1}}{|V_k| |V_{k+1}|} \cos(\delta_k - \delta_{k+1}) \quad \text{and}$$

$$\beta_{k,k+1} \triangleq \frac{R_{k,k+1}}{|V_k| |V_{k+1}|} \sin(\delta_k - \delta_{k+1})$$

Where, $\alpha_{k,k+1}$, $\beta_{k,k+1}$ are the loss coefficients. δ_k and δ_{k+1} are the voltage phase angles at the buses k and k+1 respectively. For this, BESS injected power at the identified bus will be the control variable to minimize the loss.

Equality constraints are:

$$\Delta P_k''' = P_k''' - |V_k'''| \sum_{k=1}^n |V_{k+1}| [G_{k,k+1} \cos \delta_{k,k+1} + B_{k,k+1} \sin \delta_{k,k+1}]$$

$$\Delta Q_k''' = Q_k''' - |V_k'''| \sum_{k=1}^n |V_{k+1}| [G_{k,k+1} \sin \delta_{k,k+1} + B_{k,k+1} \cos \delta_{k,k+1}]$$

Where G and B represent the conductance and susceptance and k = 1,2,3...n buses.

Inequality constraint:

$$V_k'''^{\min} \leq V_k''' \leq V_k'''^{\max}$$

B. Sensitivity analysis for Storage system installation

Loss sensitivity analysis is used to identify the candidate node for storage system installation [9]. Estimation of location for storage placement will help in the search space for the optimization process. Let us consider the section of the distribution line as shown in Fig. 2. Line impedance of the line 'm-n' is $R+jX$ and $P_{n,eff} + jQ_{n,eff}$ is the total effective power supplied beyond the node 'n'. Active power loss in the section is given by I^2R , which is given by:

$$P_{line\ loss} = \frac{(P_{n,eff}^2 + Q_{n,eff}^2) \cdot R}{V_n^2} \quad (10)$$

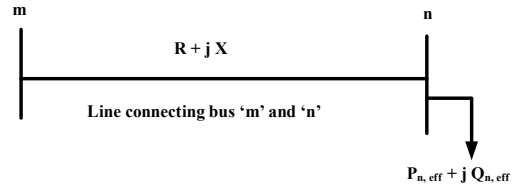

Fig. 2 Section of distribution system

A loss sensitivity factor is now calculated using equation (11).

$$\frac{\partial P_{line\ loss}}{\partial P_{n,eff}} = \frac{2 \cdot P_{n,eff} \cdot R}{V_n^2} \quad (11)$$

The sensitivity factors are calculated and arranged in descending order for all buses. It will decide the sequence at which buses will be considered for storage system installation. The size of the storage unit at the candidate bus is calculated using the Interior Point Method optimization using a hybrid optimization strategy.

C. Hybrid optimization strategy formulation

Power loss reduction considering network reconfiguration is:

$$\Delta P_{Loss}^R = P_Tloss - P'_Tloss$$

$$\Delta P_{Loss}^R = \sum_{k=1}^n P_{Loss(k,k+1)} - \sum_{k=1}^n P'_{Loss(k,k+1)}$$

Where, ΔP_{Loss}^R is the net power reduction in the system that is the difference of power loss before and after re -

configuration. Power loss reduction considering DG installation is:

$$\Delta P_{Loss}^{DG} = P_{DG,loss} - P_{T,loss}$$

Where, ΔP_{Loss}^{DG} is the net power reduction in the system equal to the difference of power loss before and after DG installation. Power loss reduction considering storage system installation is:

$$\Delta P_{Loss}^{Storage} = P_{storage,loss} - P_{T,loss}$$

$$\Delta P_{Loss}^{Storage} = \sum_{k=1}^n [\alpha_{jk}(P_j P_k + Q_j Q_k) + \beta_{jk}(Q_i P_k - P_j Q_k)] - \sum_{k=1}^n P_{Loss(k,k+1)}$$

Where, $\Delta P_{Loss}^{Storage}$ is the net power reduction in the system that is the difference of power loss before and after the installation of storage. The overall objective function is formulated in such a way that we can maximize the overall power loss reduction in the system.

$$\text{Maximize overall loss reduction} \\ = \max. (\Delta P_{Loss}^R + \Delta P_{Loss}^{Storage} + \Delta P_{Loss}^{DG})$$

Subject to:

$$V^{\min} \leq V_k \leq V^{\max}$$

$$T^{\min} \leq T \leq T^{\max}$$

$$|I_{k,k+1}| \leq |I_{k,k+1}^{\max}|$$

$$\sum_{k=1}^n P_{Gk} \leq \sum_{k=1}^n (P_k + P_{Loss,k})$$

D. Flow chart for power loss optimization considering reconfiguration, DG and BESS installation

The proposed methodology discussed in section II A, B and C is systematically connected and presented in the flow chart shown in Fig. 3. Using normal load flow, power loss in the network is observed without considering any loss minimization options as a base case. Based on the observed loss, minimization options are triggered sequentially. After each option, power loss reduction is calculated. Finally, Optimum settings and configuration are calculated which will maximize the total power loss reduction.

III. CASE STUDY

A. Network topology

The CIGRE medium voltage benchmark network is used for simulation and analysis [10]. It has the feature of typical medium voltage rural distribution network character. The benchmark network consists of two 20 kV feeders each supplied by 110/20 kV transformer. First feeder is further divided in to three branches and connected to second feeder

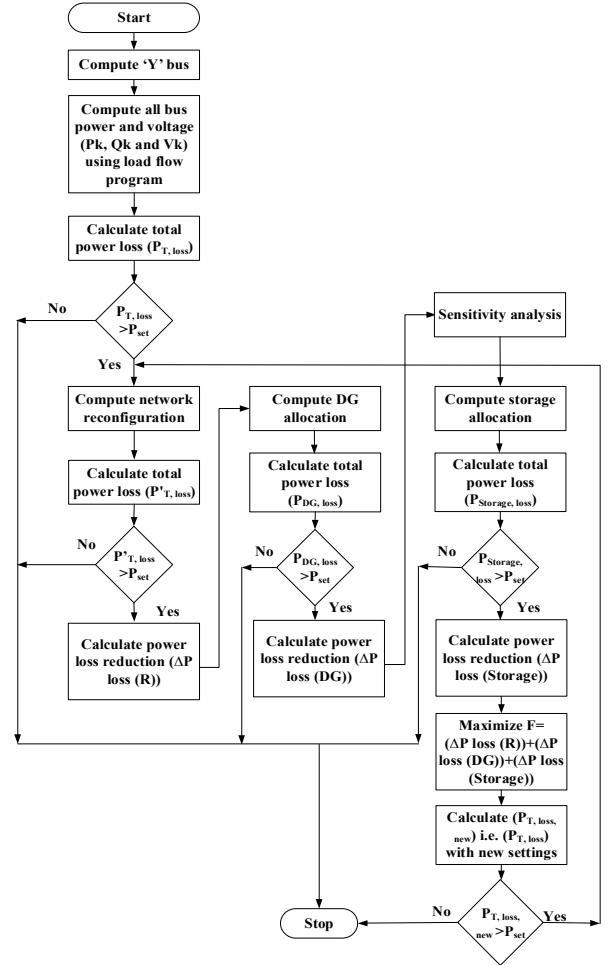

Fig. 3 Proposed methodology for Power loss optimization

with the help of three switches. There are altogether 14 nodes in the 20 kV system. Loads associated to each nodes are aggregated at the respective nodes. Most of the lines are underground cables with certain configuration. The network topology is shown in Fig. 4. As given in TABLE I, solar photovoltaic (PVs) are connected in most of the feeders to analyze the impact due to DG penetration in the system loss. Switch S1, S2, S3 and S4 are used to reconfigure the network. This will be explained later in this section. Readers are referred to [10], for network parameters and rated load capacity of the individual loads used in this work.

B. Simulation scenarios

In this work, active and reactive power dispatch from the source (-1 pu to +1 pu), voltage magnitude (-5% to +5 %), and transformer tap position (-2 to +2) are the controllable system quantities. The objective is to minimize the power loss function by optimizing the control variables within their limits. Load shedding is not allowed i.e. guaranteed power supply is aimed during optimization. Different scenarios are defined. Setups for the analysis are grouped into four different categories to investigate the impact of network reconfiguration, position of storage unit as well as DG penetration on the network power loss. Research scenarios and setups are listed as per below:

- a) Base case
- Case1: without considering loss minimization options
- b) To investigate the impact of loss minimization for different options
- Case 2: with network reconfiguration
 - Case 3: with network reconfiguration and DG
 - Case 4: with network reconfiguration, DG and storage (hybrid algorithm)

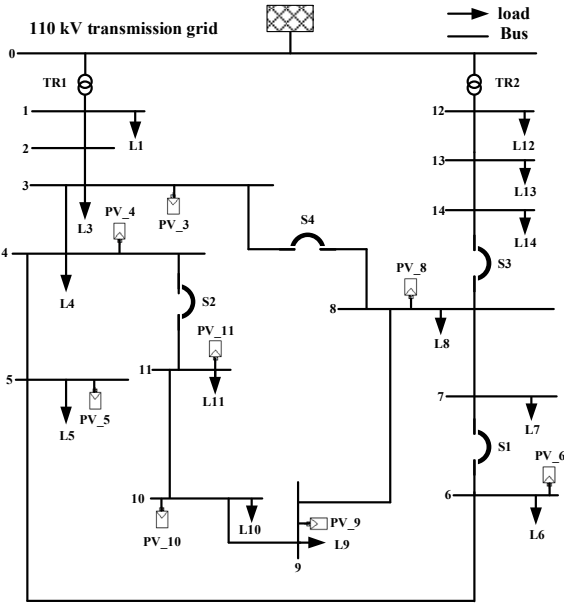

Fig. 4 MV Benchmark network topology [10]

TABLE I. PARAMETERS OF DG UNITS [10]

Node No.	DG Type	P_{max} (kW)
3	Photovoltaic	20
4	Photovoltaic	20
5	Photovoltaic	30
6	Photovoltaic	30
8	Photovoltaic	30
9	Photovoltaic	30
10	Photovoltaic	40
11	Photovoltaic	10

IV. RESULT AND DISCUSSION

The proposed hybrid loss optimization method is tested on the standard 14-bus MV distribution network as shown in Fig. 4. The optimization problem described in section II is solved using Interior Point Method. Network loss without applying optimization technique is observed first. We then calculate the impact of network reconfiguration in power loss. This is further investigated by considering DG penetration. Finally, loss minimization with storage system allocation is investigated. All

study cases mentioned above, are carried out simultaneously and the comparison of results is presented.

In base case situation, three switches S1, S2 and S3 are kept open and S4 is closed. DGs and storage systems are also not considered. Simulation is conducted for nominal load demand in the network. In this situation, power loss is calculated to 0.5 MW. In case two, there are altogether 16 possible switching combination for network reconfiguration ($2^4 = 16$). Combinations producing circulating current are filtered out to maintain the radial nature of the network to minimize the control complexities. From the remaining four combinations, power loss in each options are compared and the configuration producing minimum loss is selected. The configuration when S3 is closed and S1, S2, S4 are open is found to be the optimum configuration due to minimized power loss of 0.39 MW. In case three, installed DGs are also considered and impact of different network configuration with variation in DG penetration is investigated. Power loss is now reduced to 0.38 MW by maintaining the optimum network configuration. In case four, to identify the possible impact of storage system in power loss, the sensitivity index was calculated using equation (11), which can be seen in Fig. 5. Bus number two is found to be first choice for storage allocation due to highest sensitivity index.

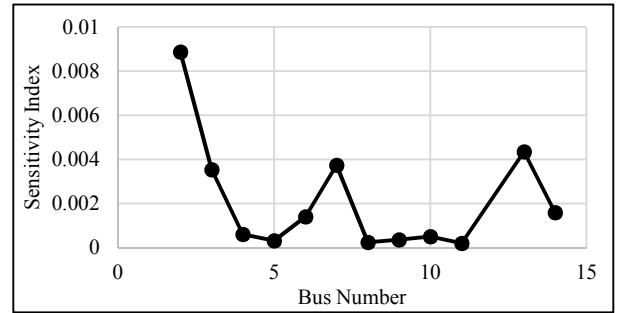

Fig. 5 Sensitivity index for storage placement

Finally, the hybrid algorithm for loss minimization is tested considering all three options together; power loss is now further reduced to 0.35 MW. Optimum configuration and settings are calculated from loss minimization point of view. Optimum transformer tap settings are identified and presented in TABLE II. Comparison of power loss minimization is shown in Fig. 6. Fig. 7 shows the voltage variation in all nodes during the optimization process. Voltage variation is maintained within 0.95 – 1 p.u. in all cases.

TABLE II. OPTIMIZED TRANSFORMER SETTINGS

Study cases	Tap settings	
	TR1	TR2
Case 1	0	1
Case 2	1	1
Case 3	1	1
Case 4	2	1

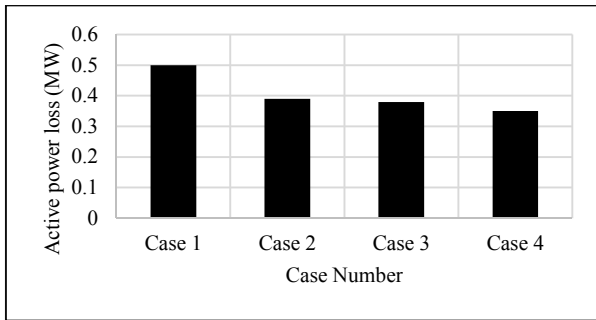

Fig. 6 Comparison of optimized power loss

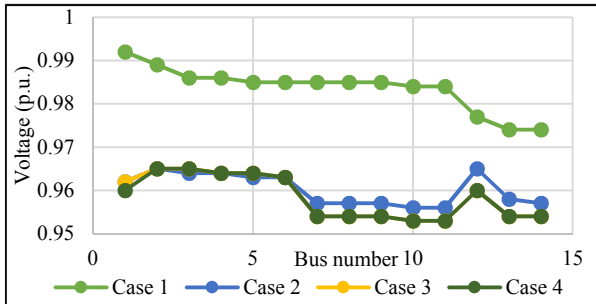

Fig. 7 Voltage variation in all nodes during optimization

V. CONCLUSIONS AND FUTURE WORKS

This paper introduces hybrid power loss optimization technique considering network reconfiguration, DG penetration and storage system. A unified model for optimization is constructed and solved considering active and reactive power limits of the generators, voltage limits and transformer tap position as controllable system quantities. The CIGRE medium voltage standard network is used as a test system for the research. The results shows that the proposed method effectively minimizes the power loss by maintaining the voltage limit in active distribution networks. Improvement in loss minimization is seen by 6%. This method can be used for network expansion planning to know the location of DSO owned storage systems and use of switches in the highly active distribution system. This work will be further investigated in future for optimum operating condition in dynamic system with periodic analysis.

ACKNOWLEDGMENT

The authors gratefully acknowledge the contributions of Energinet.dk, Eniig, Syd Energi, ABB and Kenergy for their inputs during different project meetings.

REFERENCES

[1] Angarita et.al., “Power loss and voltage variation in distribution systems with optimal allocation of distributed generation,” in *IEEE PES Innovative Smart*

Grid Technologies Latin America, 2015, pp. 214–218.

[2] Chiandone et al., “Impact of Distribution Generation on Power Losses on an Actual Distribution Network,” in *International Conf. on Renewable Energy Research and Applications*, 2014, pp. 1007–1011.

[3] M. Nick, R. Cherkaoui, and M. Paolone, “Optimal siting and sizing of distributed energy storage systems via alternating direction method of multipliers,” in *Power Systems Computation Conf.*, 2014, pp. 1–7.

[4] Rao et al., “Power Loss Minimization in Distribution System Using Network Reconfiguration in the Presence of Distributed Generation,” *IEEE Trans. Power Syst.*, vol. 28, no. 1, pp. 317–325, Feb. 2013.

[5] Morten et al., “Loss Minimization and Voltage Control in Smart Distribution Grid,” in *World Congress of the International Federation of Automatic Control*, 2014, vol. 47, no. 3, pp. 4030–4037.

[6] H. Glavitsch and R. Bacher, “Optimal power flow algorithms,” *Anal. Control Syst. Tech. Electr. Power Syst. Acad. Press Inc*, vol. 41, 1991.

[7] W. Lu, M. Liu, S. Lin, and L. Li, “Fully Decentralized Optimal Power Flow of Multi-area Interconnected Power Systems Based on Distributed Interior Point Method,” *IEEE Trans. Power Syst.*, vol. PP, no. 99, pp. 1–1, 2017.

[8] O. I. Elgerd, *Electric energy systems theory: an introduction*. McGraw-Hill, 1982.

[9] K. Prakash and M. Sydulu, “Particle Swarm Optimization Based Capacitor Placement on Radial Distribution Systems,” in *IEEE Power Engineering Society General Meeting*, 2007, pp. 1–5.

[10] K. Rudion, A. Orths, Z. a. Styczynski, and K. Strunz, “Design of Benchmark of Medium Voltage Distribution Network for Investigation of DG Intrgration,” in *IEEE Power Engineering Society General Meeting*, 2006, pp. 1–6.

Publication: C3

(Conference Paper)

An Intelligent Approach to Observability of Distribution Networks

Basanta Raj Pokhrel, N. Karthikeyan, Birgitte Bak-Jensen, Jayakrishnan R. Pillai, Seyed Mahdi Mazhari, C. Y. Chung

This paper is published in 2018 IEEE Power & Energy Society General Meeting (PESGM).

DOI: 10.1109/PESGM.2018.8585752

An Intelligent Approach to Observability of Distribution Networks

Basanta Raj Pokhrel, Student member IEEE, N. Karthikeyan, Student member IEEE, Birgitte Bak-Jensen, Senior member IEEE, Jayakrishnan R. Pillai, Member IEEE, Seyed Mahdi Mazhari*, Member, IEEE, C. Y. Chung*, Fellow, IEEE
{bap, kan, bbj, jrp}@et.aau.dk; {s.m.mazhari, c.y.chung}@usask.ca*

Abstract—This paper presents a novel intelligent observability approach for active distribution systems. Observability assessment of the measured power system network, which is a preliminary task in state estimation, is handled via an algebraic method that uses the triangular factors of singular, symmetric gain matrix accompanied by a minimum meter placement technique. In available literature, large numbers of pseudo measurements are used to cover the scarcity of sufficient real measurements in distribution systems; the values of these virtual meters are calculated value based on the available real measurements, network topology, and network parameters. However, since there are large margin of errors exist in the calculation phase, estimated states may be significantly differed from the actual values though network is classified as observable. Hence, an approach based on numerical observability analysis is introduced in this work to overcome such a critical issue. The proposed method takes the number of meters, location and choice of pseudo measurements into account and assesses the network observability. The developed method is successfully applied to a real-life Danish network, followed by discussion on results.

Index Terms—Active distribution grid, meter placement, observability, state estimation.

I. INTRODUCTION

The traditional one-way flow of power from substation to consumers is now shifting to a bidirectional structure in distribution networks. Significant interconnection of distributed resources (wind, solar etc.) and demand responses programs at both medium voltage (MV) and low voltage (LV) levels can be considered as the main culprit of this revolution. Bidirectional power flow causes security and voltage concerns [1] which makes the security assessment a compulsory task for network operators. To such aim, network states which are defined by voltage magnitudes (V) and angles (θ) at every bus of a power network, should be estimated [2]. Based on the estimated states, the entire network parameters can be retrieved which allows the operator to calculate power flow or run other required modules. In order to ensure availability of a solution set for the estimated values, observability analysis is widely used by power industries. Due to lack of sufficient measurements in the network, accurate state estimation (SE) might be impossible which means the system is unobservable. Errors in data communication as well as the topology changes

may lead to measurement scarcity, which consequently may cause unobservability. Observability of the system can be restored by installing additional measurements [3].

Observability analysis is carried out mainly by topological or numerical approaches. Topological approaches are based on decoupled measurement model and graph theory. On the other side, numerical approaches can use both fully coupled or decoupled models and are based on the numerical factorization of the measurement Jacobian or the gain matrices [4]. For both approaches, observability depends on the number of measurements, their types and locations in the network. These methods work well in transmission network due to the availability of sufficient number of metering devices. Whereas, there are less measurement in distribution systems due to economic reasons [5]. Therefore, distribution network generally operates with reduced observability. However, the use of smart meters are rapidly increasing due to development in advance metering infrastructure (AMI), [6]. The European Union (EU) is on its way to meet a goal to replace 80% of electricity meters with smart meters by 2020 [7]. Saskatoon Light and Power, a Canadian distribution system operator (DSO) have been operating their Advanced Metering Infrastructure (AMI) since July 2016 and collecting data from smart meters for both electricity and water in Saskatoon, SK [8]. Handling of this large amount of data gathered by smart meters for control application will not be cost effective. Hence, enhancement of observability in active distribution networks (ADNs) using selective minimum real measurement from smart consumer meters as well as other nodes with higher accuracy in estimated states of the observable network is the key challenge [9].

In literatures, observability challenges in distribution systems are considered from different perspective. A direct numerical method for observability analysis is described in [10]; this is evaluated in a non-iterative manner by using selected rows of the inverse factors of the gain matrix. In [11], an observability technique based on the analysis of the null space of the measurement Jacobian matrix is presented. Reference [12] purposes the use of new working matrix for observability assessment. Numerical observability analysis method based on the inverse function theory and the Jacobian matrix of the system is described in [2]. Here, unobservable branches in the system are determined by calculating the

This work is a part of “Determination of automation demands for improved controllability and observability in distribution networks” project funded by Energinet.dk through PSO-ForskEL funding

$$C = AW^T \quad (9)$$

Where, A is the incidence matrix of branches and buses of the network. From matrix C, the unobservable branches can be identified. If at least one entry in a row is not zero, then the corresponding branch will be unobservable. Observable islands can thus be obtained by removing all unobservable branches.

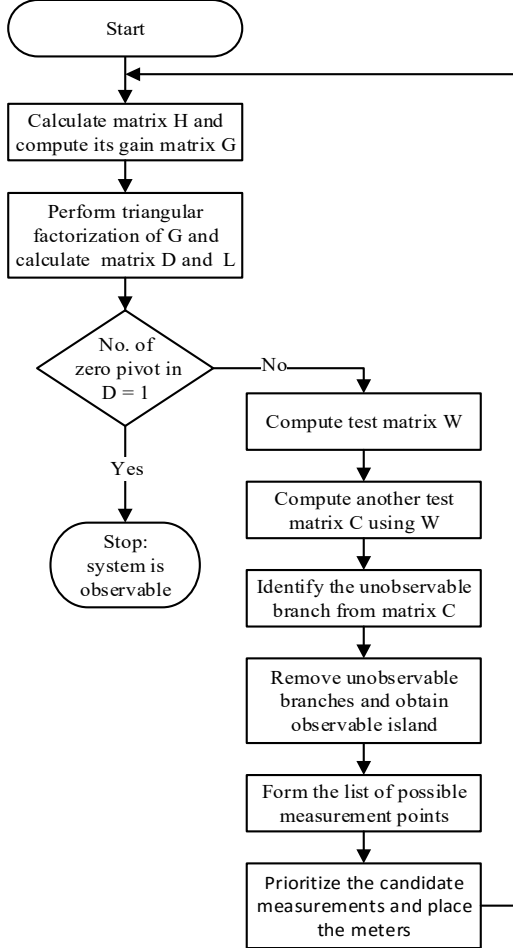

Fig. 1. The Proposed algorithm for network observability enhancement

Now, to observe the network as a whole, a list of possible measurement points can be prepared and prioritised so that improvement in network observability will be achieved with minimum number of measurements. Place the first meter at the bus that has the highest number of incident lines in the unobservable region and proceed accordingly. The candidate measurements that can merge the islands are the line flows along the branches that connects the observable islands and the injections at the boundary buses of observable islands. For the candidate measurements, a new Jacobian matrix (H_{new}) is calculated and a new test matrix B is computed as per equation (10):

$$B = H_{new}W^T \quad (10)$$

The reduced row echelon form E of matrix B is calculated. Linearly independent rows of E corresponds to the required measurement location. After selecting each new sets of

measurements as per priority, triangular factorization will be updated and checked for observability until the network is identified as observable. In distribution system, usually large number of pseudo measurements are used due to lack of sufficient real measurements to make the network observable. So, an estimated state can deviate significantly from the actual state even though the network is identified as observable. Hence, the network observability can be re-examined considering the accuracy of the estimated states. The methodology described in section III is simulated for five-bus test network and a real Denmark medium voltage (MV) network respectively and is discussed in the proceeding sections.

IV. CASE STUDY

A. Test case

In this section, performance of the network observability algorithm discussed in section III is illustrated using a five-bus test network as given in Fig. 2. Only real power measurements are used and only phase angle variables are estimated to reduce matrix size for the ease of calculation. All branch reactances are set to one per unit. Initial measurement configuration is shown in Fig. 2 where two-line power measurements and one power injection measurement are considered.

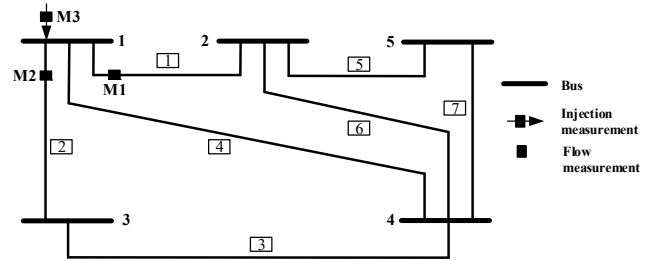

Fig. 2. Five-bus test network

Measurement Jacobian matrix H associated to Fig. 2 is:

$$H = \begin{bmatrix} 1 & -1 & 0 & 0 & 0 \\ 1 & 0 & -1 & 0 & 0 \\ 3 & -1 & -1 & -1 & 0 \end{bmatrix}$$

The gain matrix G is calculated according to equation (2) as:

$$G = \begin{bmatrix} 11 & -4 & -4 & -3 & 0 \\ -4 & 2 & 1 & 1 & 0 \\ -4 & 1 & 2 & 1 & 0 \\ -3 & 1 & 1 & 1 & 0 \\ 0 & 0 & 0 & 0 & 0 \end{bmatrix}$$

The upper and lower triangular factors of G are calculated as:

$$\text{Upper (D)} = \begin{bmatrix} 11 & -4 & -4 & -3 & 0 \\ 0 & 0.5 & -0.4 & -0.09 & 0 \\ 0 & 0 & 0.16 & -0.16 & 0 \\ 0 & 0 & 0 & 0 & 0 \\ 0 & 0 & 0 & 0 & 0 \end{bmatrix}$$

Publication: C4

(Conference Paper)

Effect of Smart Meter Measurements Data on Distribution State Estimation

Basanta Raj Pokhrel, N. Karthikeyan, Birgitte Bak-Jensen, Jayakrishnan R. Pillai

This paper is published in 2018 IEEE International Conference on Industrial Technology (ICIT).

DOI: 10.1109/ICIT.2018.8352350

Effect of Smart Meter Measurements Data On Distribution State Estimation

Basanta Raj Pokhrel, N. Karthikeyan, Birgitte Bak-Jensen, *Senior Member, IEEE*,
Jayakrishnan R. Pillai, *Senior Member, IEEE*,
Department of Energy Technology,
Aalborg University, Denmark
{bap, kan, bbj, jrp}@et.aau.dk

Abstract— Smart distribution grids with renewable energy based generators and demand response resources (DRR) requires accurate state estimators for real time control. Distribution grid state estimators are normally based on accumulated smart meter measurements. However, increase of measurements in the physical grid can enforce significant stress not only on the communication infrastructure but also in the control algorithms. This paper aims to propose a methodology to analyze needed real time smart meter data from low voltage distribution grids and their applicability in distribution state estimation. Different scenarios are created to observe the algorithm performance and effects on the estimation quality. The CIGRE benchmark network for low voltage distribution grids is used for simulation and analysis. This work also investigates the necessity of proper load modelling to reduce the stress due to huge amount of measurement data by utilizing them smartly via state estimation.

Index Terms— Smart meter measurements, active distribution grid, state estimation, observability

I. INTRODUCTION

The active distribution grids today consist of a high share of controllable distributed renewable generation sources, energy storages, flexible loads or DRRs. The share of renewable resources in Denmark is increasing rapidly to meet the target of 100% renewable energy by 2050 [1]. Smart distribution grids consists of smart metering infrastructures, which include actuators, sensors and communicable meters not only at customer location but also in feeders and at substations to collect data and act on it for operation and control. So, an unusual increase of raw measurements can be expected in such grids with the increase in levels of distributed generation (DG) penetration in future. Distribution system operators (DSO) are facing a trade-off problem between penetration of active elements in the grid, network observability and investment in the metering infrastructure [2]. This shows the necessity of real time monitoring systems embedded with state estimation (SE) in the low voltage distribution grids, which can be executed with the minimum number of measurements and communication infrastructure.

Smart meters connected at customer locations as well as remote meters at special nodes in the grid and substations are used as input by the SE. Pseudo measurement models are used for the portion of the networks where measurement data are

unavailable. Better estimation can be achieved by increasing the accuracy of pseudo modelling. Suitable combinations of measurements may be used as state variables in state estimation for higher accuracy. Most commonly used measurements are the line power flows, bus power injections, bus voltage magnitudes and line current flow magnitudes [3]. However due to the unique feature of the distribution networks the DSO cannot use traditional SE algorithms to obtain the best estimation of the operating states [4]. This is due to the complexity in developing efficient and robust estimation algorithms for multi-phase asymmetric distribution grids because of their high R/X ratio, highly varying demand and supply, high number of nodes to be monitored etc.

The meter placement location and type of measurement data varies in the literature. Most of the meter placement algorithms are developed for transmission networks. A meter placement method to reduce the variance of the estimated state variables was proposed in [5]. Here, a covariance matrix was used to minimize the variance of the states. A heuristic approach to identify the potential points for location of voltage measurements for state estimation was suggested in [6]. This technique identifies the measurement locations to reduce the voltage standard deviation of the bus bars which do not have a meter on it. In [7] a meter placement algorithm based on the properties of the error covariance matrix for distribution networks with distributed generation was proposed. An algorithm which is based on reducing the state estimation error for the voltage and its phase angle below a certain threshold is suggested in [8]. Impact of smart meter data aggregation on SE is investigated in [9]. Significant impact on voltage magnitude and angle estimation accuracies are identified and a power loss estimation method is proposed considering correlations among pseudo loads' errors in the distribution state estimation process. Most of the proposed methods are tested in high and medium voltage networks. This paper will investigate the effect of smart measurement data in distribution state estimation with respect to number of meters and their location, measurement error and use of different combinations of data set in the state estimation for the low voltage network. Finally, an evaluation procedure is proposed for the accuracy of the estimation, which is simulated and tested in the CIGRE standard LV network.

This paper is structured as follows: SE approach for smart meter data analysis and its methodology is discussed in section II and case study detail with simulation scenario is presented in section III. Section IV illustrates the results with discussions and section V concludes the paper.

II. METHODOLOGY

A. State estimation approach

DSO can use distribution SE to estimate the operating state of the network in real time. SE is a procedure to estimate the state of the system using knowledge about network topology and measurements. Plausibility check, observability analysis and optimum state calculations are the key functions of SE. So, a plausibility function of SE can be used to analyze the impact of smart meter measurement data on the accuracy of estimated states [10].

Singh et al. [11] evaluated the performance of state estimation algorithms using statistical measures: bias, consistency and quality. They concluded that compared to weighted least absolute value (WLAV) and Schweppe Huber generalized M (SHGM), weighted least square (WLS) gives consistent and better quality performance in distribution systems if noise characteristics is known.

Equation (1) represents the measurement model as in [3]:

$$z = h(x) + e_z \quad (1)$$

where, $e_z \sim N(0, R_z)$ is zero mean Gaussian noise with the error covariance matrix $R_z (= \text{diag}\{\sigma_{z1}^2, \sigma_{z2}^2, \dots, \sigma_{zm}^2\})$, z is the measurement vector with actual measurement $h(x)$ and error e_z . The normalized residual of the i^{th} measurement is defined as r_i :

$$r_i = \frac{z_i - h_i(x)}{\sigma_{zi}} \quad (2)$$

where, $r_i \sim N(0,1)$. The estimator discussed here is based on maximum likelihood theory, which relies on a prior knowledge of the distribution of the measurement error (Gaussian in this case, with zero mean and known covariance σ^2). A generalized estimation problem seeks to minimize the following objective function 'J' i.e. summation of the function of square of normalized residual of the measurement:

$$J = \sum_{i=1}^m \left(\frac{z_i - h_i(x)}{\sigma_{zi}} \right)^2 \quad (3)$$

The different estimators can be characterized based on the choice of the r_i function. WLS is a quadratic form of the maximum likelihood estimation problem. The minimization problem of equation (3) is equivalent to minimizing the sum of squares of the each residuals ' r_i ' weighted by ' W_{zi} ' as given in equation (4):

$$J = \sum_{i=1}^m W_{zi} r_i^2 \quad (4)$$

The solution of optimization problem (4) is called WLS estimator. This estimator will minimize the following objective function considering measurement errors as independent:

$$J(x) = \frac{(z_i - h_i(x))^2}{R_{zi}}$$

$$J(x) = [z - h(x)]^T R_z^{-1} [z - h(x)] \quad (5)$$

First order optimality condition will have to be satisfied at minimum. So, in compact form it can be represented as:

$$g(x) = \frac{\partial J(x)}{\partial x} = 0$$

An estimate of the state can be obtained iteratively using the Newton method according to equation (6). This is obtained by

expanding the nonlinear function $g(x)$ in to its Taylor series and neglecting higher order terms.

$$\hat{x}_{k+1} = \hat{x}_k + \left(H^T(\hat{x}_k) R_z^{-1} H(\hat{x}_k) \right)^{-1} H^T(\hat{x}_k) R_z^{-1} [z - h(\hat{x}_k)] \quad (6)$$

Where,

$$H(\hat{x}_k) = \left[\frac{\partial h(x)}{\partial x} \right]_{x=\hat{x}_k} \quad (7)$$

A smart meter measurements error modelled as in equation (1) will show the impact on the accuracy of estimated states obtained as in equation (6). Measurement errors modelled and analyzed in this work will also include impact due to location of meters, type of measured variables and quantity of measured data. If the calculated value differs from the measured value by more than the percentage given in the accuracy class, they are treated as bad data and will be filtered out by the algorithm.

B. Algorithmic concept for impact analysis

Smart meters are as a start-up considered to be connected at each load point but then selected as per the scenario considered. Data available from these meters are active power flow (P_{flow}), reactive power flow (Q_{flow}), current flow (I_{flow}) and node voltage (V). These data are supplied to the SE to analyze the impact of noise present in the measurements. Fig. 1 shows the steps and process flow for the state estimation approach to analyze measurement data and their impact on the estimated state i.e. active and reactive power of the load.

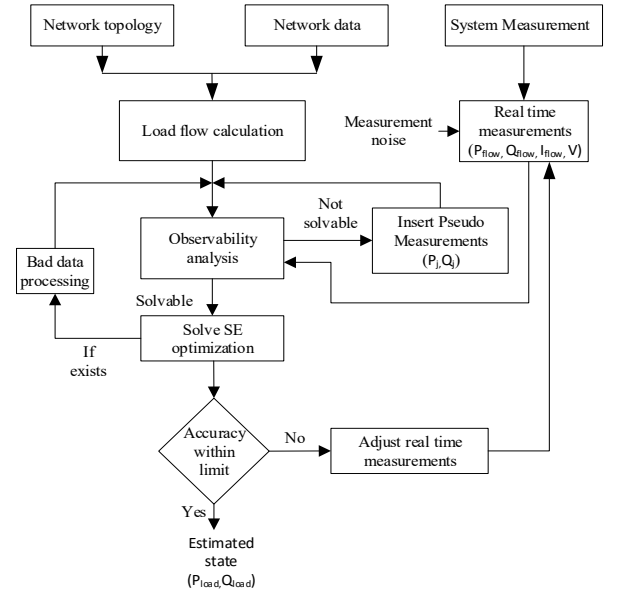

Fig. 1 Flow diagram for impact analysis using state estimation approach

The method discussed in this paper is to identify the minimum number of measurement and level of their data quality for distribution state estimation with a given accuracy. In relation to figure 1 first a load flow calculation will be carried out to initialize the SE process. If supplied measurements are not sufficient for the SE, pseudo measurements (P_j, Q_j) calculated based on the measured values are inserted to those nodes where real measurements are not available. Then the network can be observable but the accuracy of estimated states will be distorted due to error in pseudo measurements. So, minimum number of measurements and their quality for improved estimation

accuracy is calculated and inserted to replace some pseudomeasurements. In reality, separate meter placement optimization algorithm should be triggered to identify the needed meter locations (E.g.: node with more branches). However in this paper, meters are placed at all load points in the beginning and are switched off one by one. Number of meters from the selected positions that gives minimum error between the real and calculated measurements is selected as minimum meters required for state estimation for all nodes in the distribution grid. In practice, we can not have meters in all nodes in distribution grid for full observability. Following study case illustrates the way in finding the best places for meters and the best parameters to be used for distribution state estimation.

III. CASE STUDY

A. Network topology

The CIGRE low voltage benchmark network is used for simulation and analysis [12]. The simulations are carried out in DigSILENT Power Factory 2016 SP3. The benchmark network consists of three 400 V radial feeders: residential (R), industrial (I) and commercial (C). There are 18 nodes in the residential feeder with only five costumers connected to it whereas seven commercial customers are connected in the twenty node commercial feeder and finally only one industrial customer is seen in the two bus industrial feeder. All the lines are underground cables. The network topology is shown in Fig. 2. Photovoltaic (PV) generations are also connected in some feeders to analyze the impact due to DG penetration in the SE. This will be explained later in this section. Series of SE simulations have been carried out simultaneously for possible combination of feeder operation by using switches S1, S2 and S3. In reality for complex networks, Monte Carlo simulations can be used to produce statistically significant results on the state estimation accuracy.

B. Measurements and Data

Smart meters are employed in each bus where loads are connected. It is assumed that each meter is able to measure P_{flow} , Q_{flow} , I_{flow} , and V at its connection point. In this way fifty two measurements from the 13 meters in the network are considered for the base case analysis. However, fewer measurements have been used in different scenarios by switching off the selected meters respectively. Data collection set-up from smart meters is illustrated in TABLE 1.

TABLE 1 DATA COLLECTION SETUP FROM SMART METERS

Type of feeder	Number of smart meters at the beginning	Measured data
Residential	5	$I_{flow}, P_{flow}, Q_{flow}$
		V
Industrial	1	$I_{flow}, P_{flow}, Q_{flow}$
		V
Commercial	7	$I_{flow}, P_{flow}, Q_{flow}$
		V

Remote meters that can be installed in the substation cabinets are not considered in this analysis. Accuracy class of all used

meters is considered as 5% [13]. Fig. 3 shows the consumer load profile grouped in the three categories (pf - residential: 0.95, industrial: 0.85 and commercial: 0.90). All of them are connected at 400 V. Readers are referred to [12] for network parameters and rated load capacity of the individual loads used in this work.

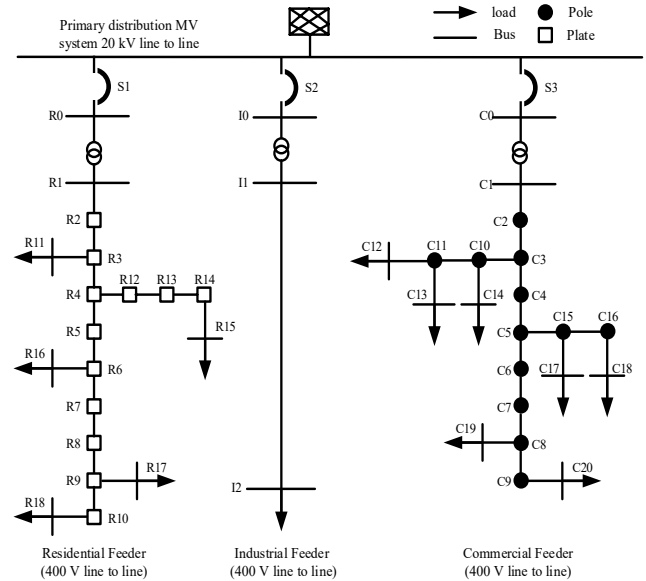

Fig. 2 LV Benchmark network topology [12]

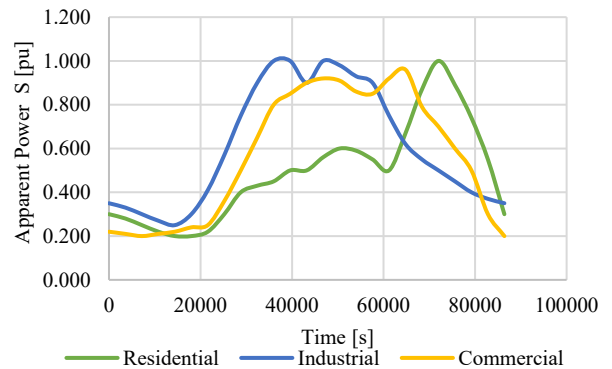

Fig. 3 Load profile [12]

C. Simulation scenarios

To evaluate the effect of smart meter measurement data on the state estimation different scenarios are defined. Setups for the analysis are grouped into three different categories to investigate the impact of measurements error, number as well as type of measurements and DG penetration on the quality of estimated states and network observability. In this work, active power (P) and reactive power (Q) of the seven loads are selected as the states to be estimated. Most of the sample loads are from the farthest end of the radial feeders and some from middle of the feeders. So, all together 14 states have to be estimated for the chosen loads: R11, R17, R18, I2, C12, C19 and C20. Research scenarios and setups are listed as per below:

- a) To identify the impact of measurements error:
 - Base case: with all available real measurements without error in any readings.

- Case1: with all available real measurements with error in some readings.
- b) To investigate the impact of the number and type of measurements considering measurements error in to account:
- Case 2: with P and V measurements
 - Case 3: with P and Q measurements
 - Case 4: with P and I measurements
 - Case 5: with P, Q and V measurements
 - Case 6: with P, I and V measurements
 - Case 7: with P, Q, V and I measurements
- c) To estimate the impact of DG penetration
- Case 8: Base case repeated with DG penetration
 - Case 9: Optimum configuration in section III C (b) repeated with DG penetration

IV. RESULT AND DISCUSSION

Performance of SE and network observability calculated using all available measurements is presented first. Next the deviation in SE quality due to noise in the measurements is shown. This is further investigated by applying different combinations of measurements as input. Effect due to DG penetration is discussed finally.

A. Effect of the error in the measurements

In the base case, the performance is off course is very good due to no error in the measurements which are sufficiently provided too. Out of the supplied 52 valid measurements, the SE uses only 18 measurements for calculation. This is because a plausibility function of the algorithm will check node sum for active and reactive power, consistent active power flow in the branch, unrealistic branch loss and loadings etc. and selects minimum best measurements from the supplied valid measurements which will be sufficient for SE optimization. All 14 selected load states are found to be observable in this case. Estimated values almost coincide with the true ones as given in Fig. 4.

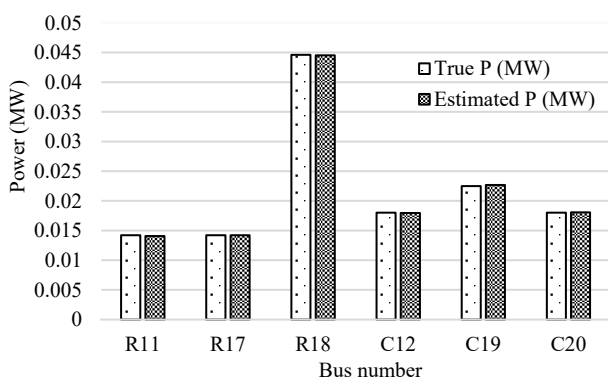

Fig. 4 Comparison of actual and estimated active power in base case

To analyze the impact due to typical measurement inaccuracy, noise in five 'P' measurements are supplied. Three meters in the commercial feeder located in line C10-C14, C11-C13, C15-C17 as well as meters located in the line R14-R15 and R6-R16 in the residential feeder are tuned to provide 'P' measurement but their values are noisy, reflecting typical

measurement inaccuracy i.e. measured value is not equal to actual load flow value. In this case, five bad data are identified and filtered out because of the difference between calculated and measured P values are higher than 5% so they are treated as bad data. In this situation, also only 18 valid measurements are used for the further calculation and all 14 states are found to be observable. All estimated 'Ps' have error less than 1% as shown in Fig. 5. Positive and negative error reflects overestimation and underestimation. More error in estimation is seen at the buses that are close to the noisy meters. In addition, the deviation between calculated and measured V is maintained within 2%, which can be seen from Fig. 6.

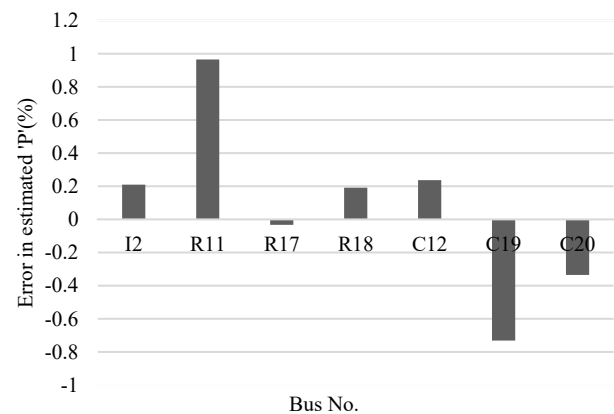

Fig. 5 Impact of measurement inaccuracy in case 1

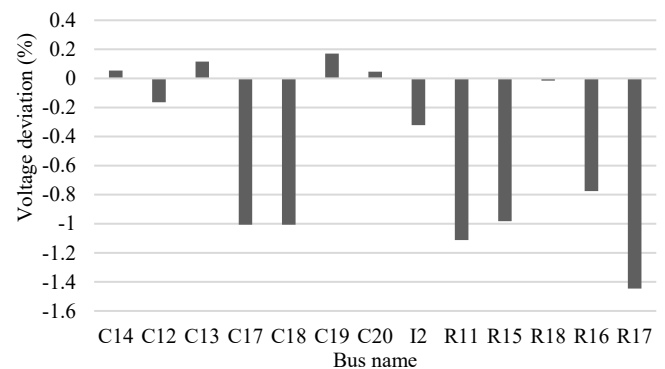

Fig. 6 Voltage deviation between calculated and measured value

An experiment by applying noise in only one meter but with double the size was also carried out during the analysis. It is found that less error spread in many meters is more severe than a high error in one meter because if more bad data are identified from many meters, SE will have to use pseudo-measurements that implies degradation in the estimation quality. Therefore, proper load modelling will be required for higher accuracy in SE, which can be used as pseudo measurements. On the other hand if a high error is found in one or two meter readings, then it can be easily filtered out by SE no matter the size of error. Then, there will be no need of psedumeasurments until number of states are not less than number of valid measurements for system observability.

B. Effect of the number and type of measurements

To investigate the influence of number of measurement data on the estimated states different meters are switched on and off as per the study cases. TABLE 2 shows the distribution of P, Q, V and I measurement data and actual quantity used by the algorithm. For each study case different combination of measurements (E.g.: PV, PQ, PI, PQV, PVI and PQVI) are supplied to identify the effect of type of input data. Here ‘P’ measurements are considered in each case to ensure the quality of estimation. Same loads are used as the states to be estimated for all setups in this study.

TABLE 2 MEASUREMENT DISTRIBUTION DETAIL

Case No.	Pseudo measurements	Used real measurements					Observed States
		P	Q	V	I	Total	
2	0	9	0	11	0	20	14
3	0	9	9	0	0	18	14
4	0	6	0	0	10	16	14
5	0	9	9	11	0	29	14
6	0	6	0	11	10	27	14
7	0	6	3	11	9	29	14
4-repeated	0	3	0	0	7	10	10
4-repeated	4	3	0	0	7	10	14

The network is found to be observable and all 14 states were estimated but huge variation in the number of measurements used by each case is seen. As observed in case 4, P and I combinations are found to be the best for PQ estimation since it uses minimum number of data with respect to the other combinations. Fig. 7 and Fig. 8 shows the estimation quality where it is seen that for most of the loads both estimated P and Q are close to actual value in case 4. Though in other cases, more data are supplied and even more data are used by the algorithm, the estimation quality was not significantly improved.

So, just by increasing the number of meters in the grid, estimation quality will not be improved. If we use proper combination of measurement data we can maintain the estimation quality to ensure the network observability with minimum number of smart meter data from the field. In real systems, we may not have access to all the required nodes for real time data and have to use pseudo-measurements for those at inaccessible locations. Forecasted load profiles can be used for pseudo load models. To realize this, case 4 is further analyzed with only 10 real measurements (3P and 7I) and 4 predefined pseudomeasurements (4P). It is observed that observability of the network is reduced by 29% with only 10 real measurements. However, observability is improved with added pseudo-measurements but estimation accuracy will be decreased with increase in pseudo-measurements. Therefore, to minimize the number of real meters in the field accurate pseudo measurement models are essential to maintain the quality of estimation.

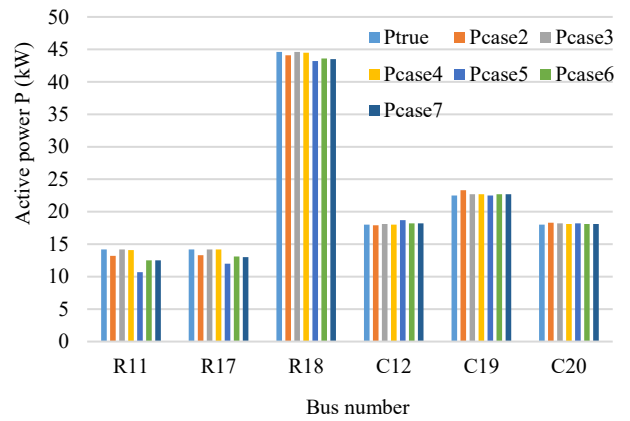

Fig. 7 Comparison of estimated active power

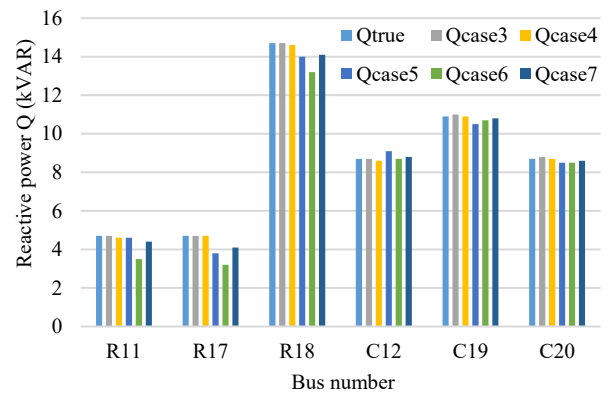

Fig. 8 Comparison of estimated reactive power

C. Effect of the DG penetration

In this analysis, both base case set up and case 4 (identified optimum configuration in section IV B) are re-simulated with PV generation integration. Two PV plants each of 50 kW are connected at buses R17 and R18 in the residential feeder. In addition to this two PV plants each of 30 kW are also connected at buses C19 and C20 in the commercial feeder. The load flow is updated and the measurements are recorded by the meters. Due to reverse power flow injected by the PV plant, power flow measured by the meter is the net power injection from the load point to the grid but not the actual power consumed by the load. So, the quality of estimated states based on this data will be distorted and proportional to the size of the PV plant. The effect on the estimation quality of both P and Q due to PV penetration is shown in Fig. 9 and Fig. 10. It is seen that estimated load at R17 and R18 are more affected due to the bulky size of the PV connected there. This effect is because estimator can not distinguish load and generation connected in same node. So, to improve this, meters placed at these two nodes are reconfigured to measure load and generation separately. This significantly improves the estimation quality, which is shown in Fig. 11. It is seen that with this slight reconfiguration in the meter, estimated states at R17 and R18 are close to the real value without much disturbing on the other estimated states. This shows that to maintain the quality of estimation in the network with high PV

penetration (PV plant size more than double the size of load connected in the same bus) selection of proper combination of measurements is not sufficient. In addition to this separate measurements of load and generation at the nodes with high PV installation has to be done.

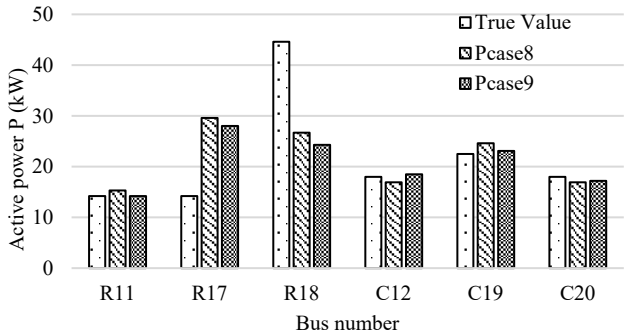

Fig. 9 Estimated and true value of active power in case 8 and Case 9

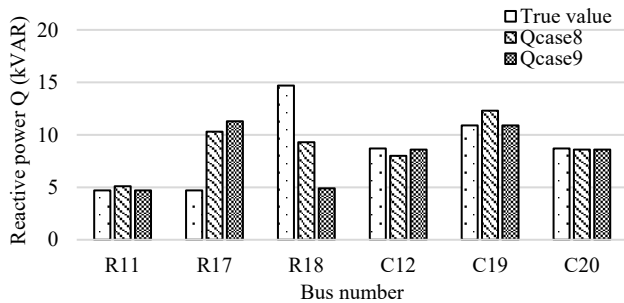

Fig. 10 Estimated and true value of reactive power in case 8 and case 9

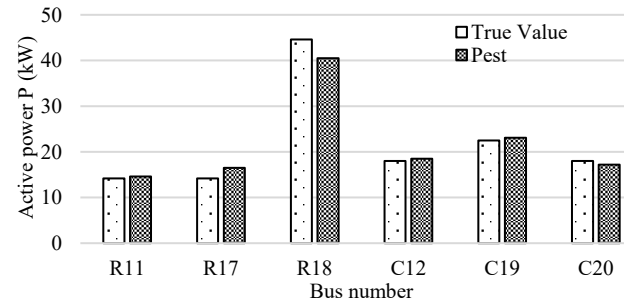

Fig. 11 Estimated and true value of active power in case 9 with adjustment in measurements

V. CONCLUSIONS AND FUTURE WORK

In this paper, a smart meter measurements data analysis method is proposed. It analyzes to what extent estimation accuracy can be maintained by using minimum number of measurement data. This can be useful to identify proper combinations of measurements data as well as meter locations to be considered for state estimation. It is shown that estimation quality can be improved even with less field measurement if we use proper combination of data from the specific locations. Based on the

results, it can be inferred that, additional preprocessing of data can be imbedded in the estimation approach to obtain robust SE. This work has been carried out in a benchmark network so future work will include validation in real networks together with load forecasting and load modelling for dynamic state estimation.

ACKNOWLEDGMENT

The authors gratefully acknowledge the contributions of Energinet.dk, Eniig, Syd Energi, ABB and Kenergy for their inputs during different project meetings and PSO-ForskEL for funding.

REFERENCES

- [1] E. and B. Danish Ministry of Climate, "Smart Grid Strategy," vol. 5, no. May, pp. 31–33, 2013.
- [2] Xue Han and Shi You et. al., "Real-time Measurements and their Effects on State Estimation of Distribution Power System," *ISGT Eur.*, pp. 1–5, 2013.
- [3] A. Abur and A. Exposito, *Power system state estimation: theory and implementation*. 2004.
- [4] Y. Weng, R. Negi, C. Faloutsos, and M. D. Ilic, "Robust Data-Driven State Estimation for Smart Grid," *IEEE Trans. Smart Grid*, vol. 8, no. 4, pp. 1956–1967, Jul. 2017.
- [5] F. C. Schweppe, "Power System Static-State Estimation, III : Implementation," *Trans. Power Appar. Syst.*, vol. PAS-89 NO., no. 1, pp. 130–135, 1970.
- [6] R. Mahanty and P. Gupta, "Measurement location for state estimation of distribution networks with generation," *IEE Proceedings-Generation, Transm. Distrib.*, vol. 152, no. 2, 2005.
- [7] R. Singh, B. C. Pal, and R. B. Vinter, "Measurement Placement in Distribution System State Estimation," *IEEE Trans. POWER Syst.*, vol. 24, no. 2, pp. 668–675, 2009.
- [8] I. Cobelo, A. Shafiu, N. Jenkins, and G. Strbac, "State estimation of networks with distributed generation," *Eur. Trans. Electr. Power*, vol. 17, no. 1, pp. 21–36, 2007.
- [9] Q. Chen, D. Kaleshi, Z. Fan, and S. Armour, "Impact of Smart Metering Data Aggregation on Distribution System State Estimation," *IEEE Trans. Ind. Informatics*, vol. 12, no. 4, pp. 1426–1437, 2016.
- [10] Wellssow et al., "Linear State Estimation in Low Voltage Grids Based on Smart Meter Data," in *CIGRE*, 2016, vol. C6-111.
- [11] R. A. Jabr, B. C. Pal, and R. Singh, "Choice of estimator for distribution system state estimation," *IET Gener. Transm. Distrib.*, vol. 3, no. 7, pp. 666–678, 2009.
- [12] K. Strunz and Et.al, "Benchmark Systems for Network Integration of Renewable and Distributed Energy Resources," no. 273, pp. 4–6, 2014.
- [13] F. Adinolfi, F. Baccino, F. D'Agostino, S. Massucco, M. Saviozzi, and F. Silvestro, "An architecture for implementing state estimation application in Distribution Management System (DMS)," *ISGT Eur. 2013*, no. 1, pp. 1–5, 2013.

Publication: C5

(Conference Paper)

**Coordinated Control with Improved Observability for Network Congestion Management in
Medium-Voltage Distribution Grid**

N. Karthikeyan, Basanta Raj Pokhrel, Jayakrishnan R. Pillai, Birgitte Bak-Jensen, A. Jensen,
T. Helth, J. Andreasen, and K. H. B. Frederiksen

This paper is published in CIGRE Session, Paris, 2018.

DOI: https://e-cigre.org/publication/SESSION2018_C2-134

Coordinated Control with Improved Observability for Network Congestion Management in Medium-Voltage Distribution Grid

**N. KARTHIKEYAN^{1*}, BASANTA RAJ POKHREL¹, JAYAKRISHNAN R. PILLAI¹,
BIRGITTE BAK-JENSEN¹, ALLAN JENSEN², THOMAS HELTH², JACOB ANDREASEN³
KENN H. B. FREDERIKSEN⁴**

¹Aalborg University, Aalborg, Denmark

²Eniig A/S, Denmark

³Syd Energi A/S, Denmark

⁴Kenergy consultant, Horsens, Denmark

SUMMARY

Increasing amount of renewables in the medium and low-voltage distribution systems is causing challenges to realize a stable and reliable operation of the grid. Especially, the power production from renewable power sources such as solar and wind may cause reverse power flow and voltage rise in the medium-voltage distribution network. Without proper control measures, due to fluctuating renewable power production, power flows in some parts of the distribution network may exceed the thermal and voltage limits and cause overloading of the network assets. These conditions are called network congestions in this paper. The distribution system operators in coordination with the transmission system operator has to manage the power flow to avoid such congestions. This work addresses two aspects to manage network congestions: (i) observance of the network by means of load/generation forecasting and dynamic state estimation, (ii) optimal control of the flexible network assets. These are linked to the electricity market to utilize the ancillary services offered by the flexible resources in the network. These services could be purchased by the distribution system operator during network congestions. The proposed observability module gets measurements from a minimum set of network nodes and ensures full observability of the network. A coordinated control algorithm is proposed to compute the aggregated flexibility at each MV bus, which can be used by the area controllers at each MV bus to control the individual flexible resources connected to the MV bus or distributed at the LV network. These modules get inputs from the state estimation and forecasting algorithms. The objective of the proposed control is to accommodate maximum power from renewable energy sources and maintain the power flows within the thermal and voltage limits of the feeder. A model predictive control algorithm based on conic programming with quadratic constraints is used to achieve the above objective. The proposed algorithm is applied and tested in a simulation platform using DigSilent Power factory and Matlab software using a model of a real-life Danish 10 kV medium-voltage distribution network. The results obtained are therefore directly applicable to Danish distribution network grids and may be feasible in other countries with similar grid structures.

KEYWORDS

Active distribution network, load forecasting, network congestions, predictive control

I. Background and State of the Art Review

Denmark is one among many countries progressing on the path to eliminate fossil-fuel based power generation and replace it with small, decentralized generation based on green technologies. A detailed review of the challenges and possible solutions for deployment of the distributed energy resources (DER) in Denmark is presented in [1]. One of the main challenges in a modern distribution grid with increasing amount of renewables is wide-variation in power flow depending on climatic conditions. The technical issues and recommendations to increase the penetration of renewable energy sources in distribution grids are discussed in [2]. The responsibilities of the distribution system operator (DSO) will be to monitor and manage the congestions in medium-voltage (MV) distribution grids (over-voltages and overloading of feeders) and provide better visibility to the transmission system operator (TSO) [3], [4]. The network congestions in medium-voltage (MV) distribution grids can be sensed only if the critical points of the feeder are measured and the system state is estimated by a dynamic state estimation (DSE) algorithm. In [5], methods to improve state estimation accuracy using aggregated measurement data are proposed. An advanced distribution management system (DMS) as discussed in [6] is required to fulfil the control requirements and overall optimization of the system operation.

II. Network Congestion Management

Among many possible solutions available to manage network congestions, active power curtailment of wind and solar power generation is the easiest and most widely used method. With the advent of smart grid technologies, the flexible assets can be utilized effectively to manage network congestions. However, to make the overall control action effective, the network should be observable. Hence, in this work, a novel distribution state-estimation (DSE) algorithm, which requires less measurement points compared to conventional methods, is employed. A coordinated control strategy has been formulated to compute the aggregated flexibility at each MV bus. The proposed control algorithm realizes assets coordination through its interface to the electricity market mechanism [7].

In this work, network congestion management (CM) is done at two stages named as congestion management-planning (CMP) and congestion management-operation (CMO) respectively. The CMP works on a day-ahead basis and as the name suggests, this algorithm calculates the optimum flexibility to be procured from the day-ahead market. The CMO algorithm works close to real-time with a time-step of 10 min. This algorithm along with DSE detects network congestions and calculates aggregated setpoints for DER and demand response resources (DRR) at each MV bus, which are communicated to area controllers of each MV bus. The area controller at each MV bus is responsible for calculation of individual power setpoints to each DER and DRR unit, which either are connected directly to the MV bus or present throughout the LV network connected to the MV bus. Both the above CM algorithms work based on a model predictive control (MPC) algorithm using second-order cone programming (SOCP) based relaxation of the original nonlinear power flow equations. This method is used for finding the optimal change in DER production and DRR consumption. Due to the receding horizon control property of the MPC method, the values of the flexibility are calculated not only for the present time but also for the targeted future period. The calculated flexibility values for the future period can be procured from the market in advance. Fig. 1 shows the proposed schematic of the network congestion management system in a MV distribution grid which uses a MPC based control algorithm for finding the optimum control signals (active and reactive power set points) to the aggregated DER and DRR.

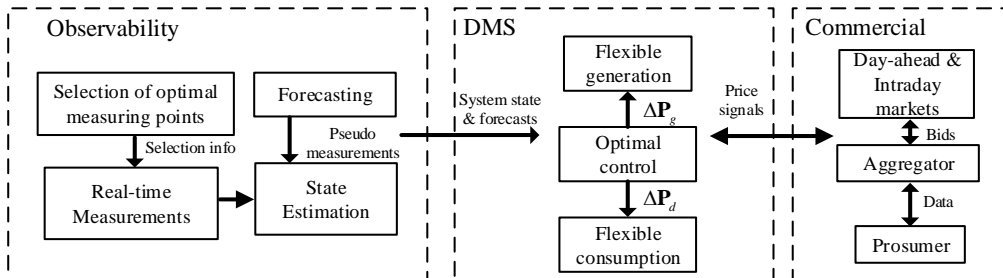

Fig. 1. Proposed schematic for network congestion management.

As shown in Fig. 1, the DMS in the proposed method is interfaced with the observability and commercial layers. The DMS receives forecasting of generation and load aggregated at each MV bus, system state information (voltage magnitudes, power flows etc.,) from observability blocks and market price signals of the flexible DER and DRR power from the electricity market. The congestion management algorithm, which is a part of the DMS, uses the received information to compute the optimum change in generation (ΔP_g) and demand (ΔP_d) to remove the network congestions.

III. Proposed Network Observability Methods

The proposed network congestion management depends on the network state and load/generation forecasting data for its operation. In this section, the proposed methods for network observability are presented.

A. Proposed Network Observability and State Estimation

To observe the network with adequate accuracy, a simple algebraic algorithm is used to determine the observable island of the measured power system. Observability of the network is predicted using the information traced from the triangular factors of the system's gain matrix. A state estimator is proposed to estimate the state of the observable network, which is computationally efficient and robust. Based on statistical measures such as bias, consistency and quality, the Weighted Least Squares (WLS) estimation method gives consistent and better quality performance in power distribution systems compared to other methods like weighted least absolute value (WLAV) and Schweppe Huber generalized-M (SHGM) algorithms [8]. In the proposed method, the WLS algorithm is modified to use an optimum number of real measurements supported by optimum meter placement. System measurements, network topology and forecasted data are inputs for the state estimation algorithm as presented in Fig. 2. The data processing block identifies the required pseudo-measurements and sends the information for state estimation optimization. Bad data is filtered out and the total variance of the state estimation error is calculated and sent back to the meter optimization algorithm. The meter allocation approach is evaluated by analyzing the relation of measurement location, total variance of state estimation (SE) error and network parameters [5], [9]. In the proposed algorithm, the objective is to minimize the total variance of state estimation error subjected to optimum number of meters. Data received through these meters is supplied to the module, which filters out noise, confirms network observability and passes the information of network state to the network congestion management.

B. Proposed Forecasting of Network Load and Generation

Future load and generation profiles for a given period are prepared using forecasting techniques and history data. A short-term forecasting technique is proposed for higher accuracy considering weather forecast, historic load/generation statistics and social events. Due to the ability to represent both linear and non-linear relationships, and the ability to learn the relationships directly from the data, an artificial neural network (ANN) technique [10]–[13] is applied. An ANN with four input nodes, two layers (one of which is hidden), and two output neurons as discussed in [10] is used in this work. The parameters of the ANN are the forecasted values y_k , inputs x_k , weight matrix $w_{3 \times 4}$ (containing the weights $w_{i,j}$ that connect the neuron i to the input j), weight matrix $u_{2 \times 3}$, and the bias vector $\theta_{5 \times 1}$. The bias term is required to shift the threshold of the firing curve of the activation function.

$$y_k = \sum_{j=1}^3 \left(u_{jk} \frac{1}{1 + e^{-\sum_{i=1}^4 w_{ji}x_i + \theta_j}} \right) + \theta_k \quad (1)$$

History of load, holidays and weather data are used for training and testing the ANN. Stopping criterion for training the ANN is based on absolute percentage error (APE) and mean absolute percentage error (MAPE) which are determined as provided below.

$$APE = \frac{|Load_{forecast} - Load_{actual}|}{Load_{actual}} \times 100 \quad (2)$$

$$MAPE = \frac{1}{N_h} \sum_{N_h} APE \quad (3)$$

where, N_h is the number of hours in the forecasting period. Correlation analysis (R) using (4) is carried out to identify the most influencing factors for load forecasting.

$$R = \frac{\sum (x - \bar{x})(y - \bar{y})}{\sqrt{\sum (y - \bar{y})^2 \sum (x - \bar{x})^2}} \quad (4)$$

After training the ANN, it is tested using the test data set and the errors APE and MAPE are calculated to be less than the 5%.

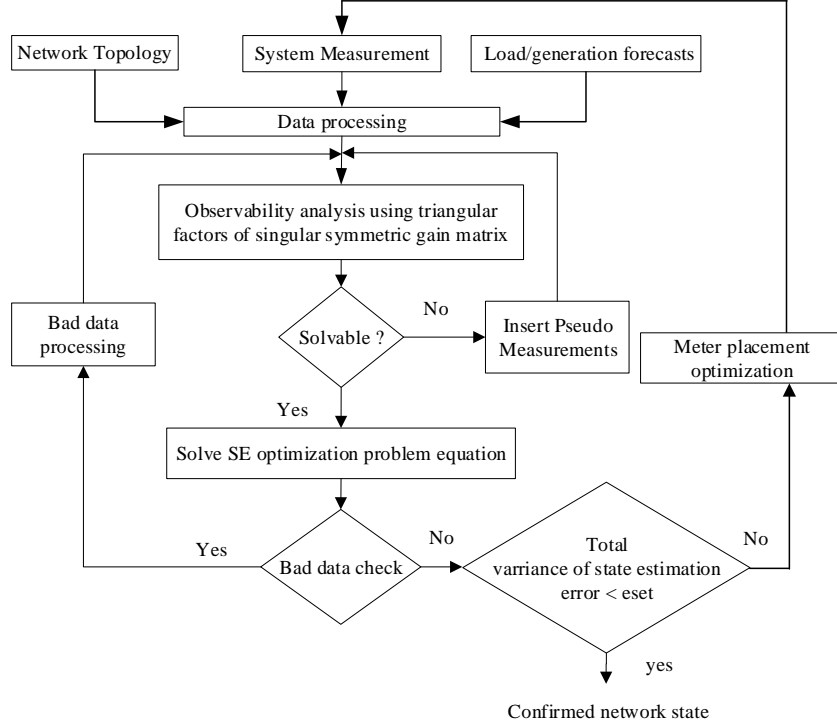

Fig. 2 Process flow chart for network observation and state estimation

The proposed state estimation and forecasting algorithms are integrated with the congestion management algorithms. The data passed from the forecasting algorithm are the predicted generation (\hat{P}_g) and load (\hat{P}_d) for the required period (24 hours for CMP and 1 hour for CMO algorithm respectively).

IV. Proposed Optimal Control Method

The algorithm for the proposed congestion management system has two parts, which are the CMP and CMO algorithms. Both these modes are explained based on the steps involved in solving the network congestions as provided below.

Sequence of execution: Congestion Management-Planning

1. Start at 12:00 of each day. Forecasting algorithms read data (historical information of energy flows and network status) from the data hub about the network.
 2. DER and DRR aggregators receive the data about availability of network resources from all nodes of the MV network. This includes the distributed solar PV and DR assets at each LV network aggregated at the MV node.
 3. DER and DRR aggregators submits the hourly energy bids to the day-ahead market for the next day. The day-ahead market receives this information along with the bids from the TSO for ancillary services.
 4. The day-ahead market agent sends the provisional schedule to the DSO.
-

5. DSO receives day-ahead forecasts of aggregated generation and loads at each MV bus and network information. DSO runs the optimization program to check for network congestions during 00:00 to 24:00 hr of next day using CMP algorithm.
6. If network congestions are expected based on forecasts, DSO submits bids to the day-ahead market.
7. The final schedule is prepared by the day-ahead market and it is communicated to the DSO, DER and DRR aggregators.
8. DER and DRR aggregators communicate the final schedule to all the individual DERs and DRRs.
9. Remain idle for 12 hours until 00:00 hr of next day and go to step 1.

The sequence of steps for the CMO algorithm is provided below.

Sequence of execution: Congestion Management-Operation

1. DSE and forecasting blocks read data from the network through the data hub.
2. Forecasting algorithm provides pseudo-measurements to DSE block
3. CMO algorithm receives updated forecasts of load and generation and system state
4. CMO algorithm checks for any congestions in the network within the next time-step. If yes, it submits the regulation power bids to the intraday market to purchase the flexibility.
5. Intraday market agent sends the available regulation reserves information to the CMO.
6. Intraday market agent sends CRP signal to DER aggregator and DR price signal to DRR aggregator so as to activate the interested parties to respond to control signals from the DSO.
7. The CMO block sends the aggregated setpoints of DER and DRR at each MV bus for the next time step to the area controllers.
8. Each area controller at MV bus computes individual setpoints for each DER and DR, which are connected directly to MV bus, or the distributed units at the LV bus connected to the MV bus.
9. Wait for the next time step and go to step 1.

The schematic of CMP and CMO algorithms along with signal flows among various blocks are depicted in Fig. 3.

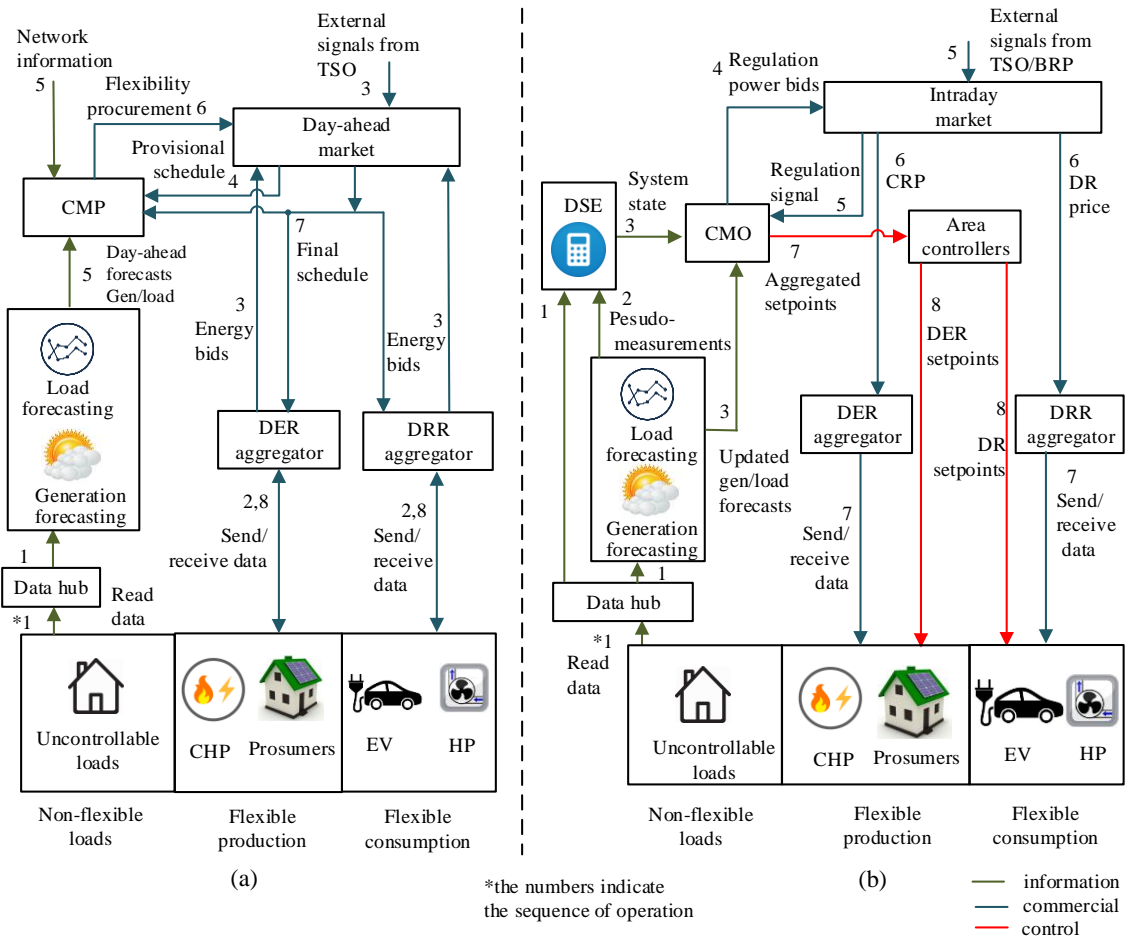

Fig. 3. Proposed congestion management algorithm (a) planning (CMP) and (b) operation (CMO)

The mathematical formulation of the congestion management algorithm is provided below.

A. Formulation of Optimal Coordinated Control for Congestion Management

The optimal power flow formulation based on second-order cone programming (SOCP) [14] provided below is proposed for congestion management. Compared to other optimization methods such as linear programming and semi-definite programming, the SOCP method is used in this method, because this method provides accurate and global optimal solution for radial distribution networks [14]. Due to the linearity of the objective function defined in (5), the SOCP formulation is a conic relaxation of the original nonlinear power flow problem defined in (12) with quadratic constraints. Let $\ell_{bi} = |I_{bi}|^2$ represent the square of the branch current between nodes i and $i+1$, and $v_{ni} = |V_{ni}|^2$ be the square of voltage magnitude at node i . In a radial network with N nodes and B branches, the relation $N = B + 1$ is valid. Let the vectors \mathbf{c}_{gc} , \mathbf{c}_{dr} of size $B \times 1$ be the costs of the flexibility in generation (curtailment of active power) and load (demand response) respectively and c_{ls} be the cost of total branch power loss. Let the vectors \mathbf{P}_g , \mathbf{P}_d of size $B \times 1$ be the flexible generation and flexible load respectively and P_{loss} be the total branch power loss of the MV network. The vectors $\hat{\mathbf{P}}_g$ and $\hat{\mathbf{P}}_d$ indicates the predicted generation and load respectively. The index k in the equations (5) to (18) is part of the set $\mathcal{N} = \{1, \dots, N_p\}$ where N_p is the prediction horizon. The variables P_b and Q_b indicate the branch active and reactive power flows respectively. The variables R_b and X_b are the branch resistances and reactances respectively. The non-flexible generation and loads present at each node are accounted while calculating the net power injection (P_n and Q_n) at equations (9) and (10). Using the *DistFlow* equations proposed in [15], the power flow equations (9), (10) and the quadratic constraint in (12) is written. The objective function of the flexibility estimation is defined as

$$\min_{\mathbf{u}} J = \sum_{k \in \mathcal{N}} \left(\mathbf{c}_{gc,k}^T \Delta \mathbf{P}_{g,k} + \mathbf{c}_{dr,k}^T \Delta \mathbf{P}_{d,k} + c_{ls,k} P_{loss,k} \right) \quad (5)$$

subjected to the following constraints

$$\Delta \mathbf{P}_{g,k} = (\hat{\mathbf{P}}_{g,k} - \mathbf{P}_{g,k}) \quad k \in \mathcal{N} \quad (6)$$

$$(\hat{\mathbf{P}}_{d,k} - \mathbf{P}_{d,k}) \leq \Delta \mathbf{P}_{d,k} \quad k \in \mathcal{N} \quad (7)$$

$$-(\hat{\mathbf{P}}_{d,k} - \mathbf{P}_{d,k}) \leq \Delta \mathbf{P}_{d,k} \quad k \in \mathcal{N} \quad (8)$$

$$P_{bi,k} = R_{bi} \ell_{bi,k} - P_{nj,k} + \sum_{m:j \rightarrow m} P_{bj,k} \quad \forall i=1, \dots, B-1; k \in \mathcal{N}; j=i+1 \quad (9)$$

$$Q_{bi,k} = X_{bi} \ell_{bi,k} - Q_{nj,k} + \sum_{m:j \rightarrow m} Q_{bj,k} \quad \forall i=1, \dots, B-1; k \in \mathcal{N}; j=i+1 \quad (10)$$

$$v_{nj,k} = v_{ni,k} - 2(R_{bi} P_{bi,k} + X_{bi} Q_{bi,k}) + (R_{bi}^2 + X_{bi}^2) \ell_{bi,k} \quad \forall i=1 \dots B-1; k \in \mathcal{N}; j=i+1 \quad (11)$$

$$\left\| \begin{bmatrix} 2P_{bi,k} & 2Q_{bi,k} & \ell_{bi,k} - v_{ni,k} \end{bmatrix}^T \right\|_2 \leq \ell_{bi,k} + v_{ni,k} \quad \forall i=1 \dots B; k \in \mathcal{N} \quad (12)$$

$$P_{loss,k} = \sum_{i=1}^B R_{bi} \ell_{bi,k} \quad k \in \mathcal{N} \quad (13)$$

$$\Delta \mathbf{P}_{g,k} \geq 0 \quad k \in \mathcal{N} \quad (14)$$

$$\mathbf{P}_{g,k,\min} \leq \mathbf{P}_{g,k} \leq \mathbf{P}_{g,k,\max} \quad (15)$$

$$\mathbf{Q}_{g,k,\min} \leq \mathbf{Q}_{g,k} \leq \mathbf{Q}_{g,k,\max} \quad (16)$$

$$\ell_{bi,k,\min} \leq \ell_{bi,k} \leq \ell_{bi,k,\max} \quad \forall i=1, \dots, B; k \in \mathcal{N} \quad (17)$$

$$v_{ni,k,\min} \leq v_{ni,k} \leq v_{ni,k,\max} \quad \forall i=1, \dots, N; k \in \mathcal{N} \quad (18)$$

where the optimization variables are $\mathbf{u} = \{\mathbf{P}_g, \mathbf{Q}_g, \mathbf{P}_d, \mathbf{Q}_d, P_{loss}, \ell, v\}$. In addition to the above constraints, maximum limit on available DR given by $\Delta \mathbf{P}_d \leq \Delta \mathbf{P}_{d,max}$, the rate limit for DR activation given by $|\mathbf{P}_{d,k+1} - \mathbf{P}_{d,k}| \leq \mathbf{P}_{dr,lim}$ where, $\mathbf{P}_{dr,lim}$ is the rate limit of the DR at each time step is also applied. The constraint in (14) means that only down regulation of power is possible with a DER.

The coordinated control is achieved by employing MPC algorithm [16] for congestion management and the optimal solution is found by minimizing the cost function J as defined in (5). The solution of the above SOCP problem is found at each time step for the prediction horizon N_p but only the values computed for the time instant $k+1$ are applied to the network. The optimization problem is again solved at the next time step with updated information (feedback from the network) to compute the updated control inputs.

V. Simulation Studies using Proposed Method

The proposed method for congestion management is tested in a model of a real-life Danish 10 kV MV distribution grid of Lind area as shown in Fig. 4. DigSilent Power factory and Matlab are used for the modelling and simulation of this network. The loops between M5 to M25, M10 to M14, and M14 to M22 are kept open to maintain the radial structure of the network in the below simulation studies.

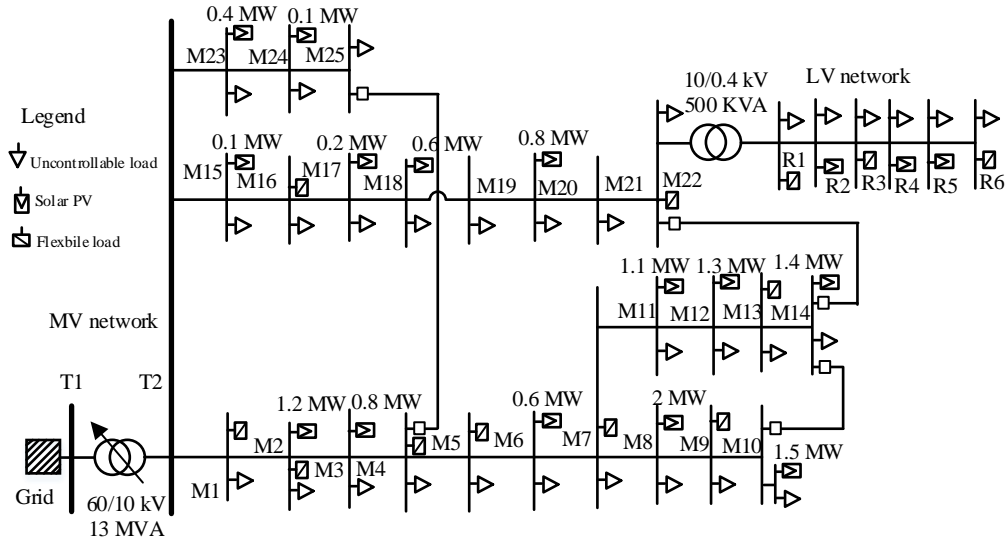

Fig. 4. Schematic of simplified MV network of Lind, Denmark.

The power production of PV plants connected at various nodes of the feeder as shown in Fig. 4 are varied to create network congestions at some parts of the network. The developed observability modules with novel DSE and optimal measurements are tested to identify the network congestion. The network status are provided to the CMP and CMO algorithms for finding the optimum flexibility. The computed flexibility is purchased from the market and the area controller determines the power setpoints of the individual DER and DRR connected to each MV bus. The following simulation scenarios are considered for the verification of the proposed methodology.

A. Simulation to Validate Forecasting Method

The network given in Fig. 4 is used for simulation and analysis of the forecasting method explained in section III B. Forecasted values are used by the state estimation as pseudo measurements where the real measurements are not available. The history of load data from a Danish LV grid in Støvring area is scaled up to get the load at MV and used for training the forecasting ANN algorithm. Comparison of actual and forecasted loads is given in Fig. 5. MAPE for domestic load and agricultural loads are found to be 4.768% and 9.693% respectively. From the correlation analysis it is found that history of load and weather data specially temperature, humidity are highly correlated with the forecasted load.

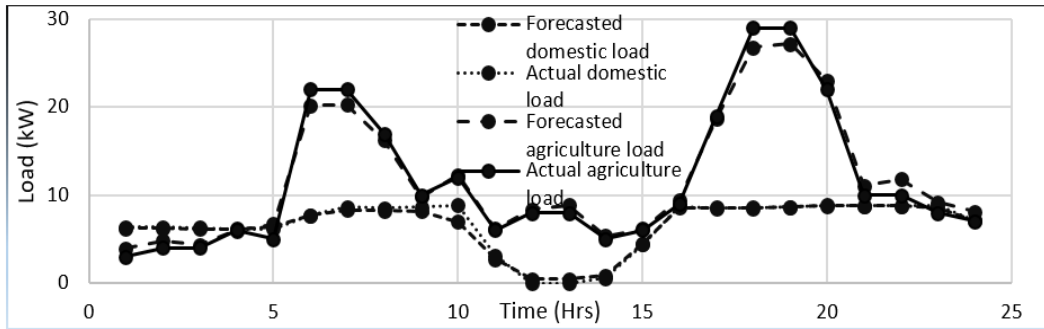

Fig. 5 Comparison of actual and forecasted load for 24 hours (Domestic and Agriculture load)

The training of ANN is repeated considering weather data together with time factors (holiday details, weekdays, weekend, etc.), standard holidays (Christmas, New Year, Easter etc.) spread over the test year in Denmark. Sample weather data from Alborg University’s lab are also used in this process. Comparison of actual and forecasted load after rigorous training of the ANN is given in Fig. 6. MAPE for domestic load and agricultural loads are improved to 2.537% and 3.759% respectively.

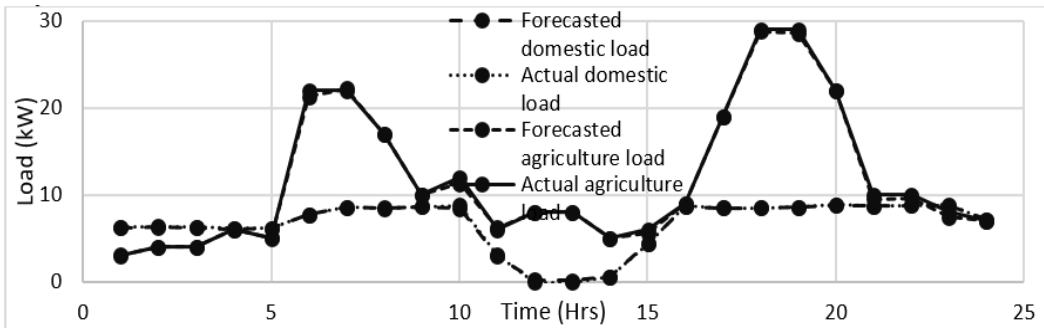

Fig. 6 Comparison of actual and forecasted load for 24 hours (Domestic and Agriculture load) considering other factors also.

The forecasted values of different types of loads are used by the state estimation algorithm as a pseudo measurement based on the requirements. Observability analysis of the network Fig. 4 is carried out applying triangular factorization technique using gain matrix of measurements sets. Minimum number of real measurements are selected by using the meter prioritizing technique where meters are placed first in buses with more number of branches in it. Observable islands are identified and then buses at the boundary of observable islands are selected as meter locations to improve the observability of the network as a whole. Once the network is identified as a single observable island, state estimation is carried out to identify the real state of the network and study network congestions. With initially assumed nine available measurements (Injection: bus T2, M6, M10, M25, M18, M22 and flow: M4-M25, M10-M14, M14-M22) and optimally added 4 measurements (Injection: M4, M7, M16, M24) the network is found to be observable. The total 13 measurements used are the combinations of pseudo- measurements and real measurements. Forecasted load and generation are used as pseudo-measurements. State estimation is done on the network and the state (voltage magnitudes and angles at each MV bus) of the network is estimated as shown in Fig. 7. The values shown in Fig. 7 are obtained in a scenario where the network load is at its peak; hence, the voltages at the far end nodes are close to the allowed limit of 0.9 pu.

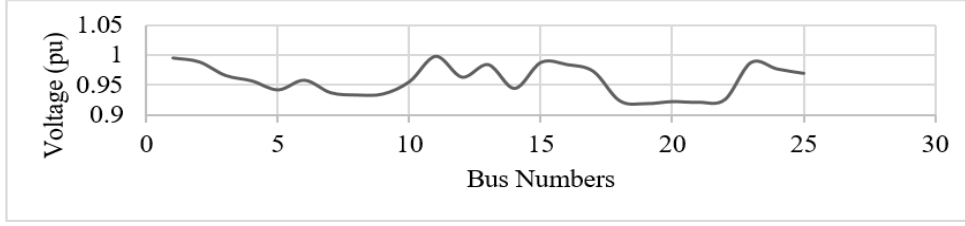

Fig. 7 Snap shot of estimated voltages

B. Simulation to Validate the CMP Algorithm

The day-ahead operation of the CMP algorithm is simulated using a high PV production scenario of a summer day in Denmark. The generation and load forecasts for 24 hours duration (\hat{P}_g, \hat{P}_d) obtained from the forecasting algorithm are used to run the CMP algorithm. The algorithm solves the optimization problem defined in (5) to (18) for a prediction horizon (N_p) of 24 hours with a time-step of 1 hour. The solar power production in MV buses M8 to M14 are set to values such that the reverse power flow in the branch between M6 and M7 is 110%. It is to be noted this is just a simulation scenario, which today is not occurring in the real network. However, this scenario is used to test CMP algorithm. The costs of DR (c_{dr}) is set to be much lower than other costs (c_{gc}, c_{ls}) in (5) based on the assumption that the flexible loads are available at cheaper prices at MV buses M8 to M14 and to accommodate maximum renewable power generation [7]. The total flexibility estimated by the CMP is 2.5 MW from the MV buses M7, M7 and M14. The calculated flexibility can be bought by the DSO from the day-ahead market to prevent network congestions at the predicted future period. The loading of branches from M6 to M14 without and with DR are shown in Fig. 8. As seen in Fig. 8, after activating the flexibility from the DRR, the branch over-loading is avoided.

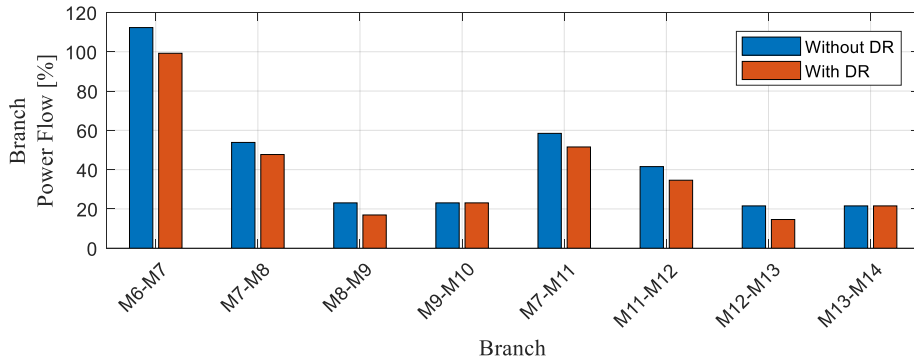

Fig. 8. Branch loading without and with flexibility from DR.

C. Simulation to Validate the CMO Algorithm

As discussed in previous sections, the purpose of CMO algorithm is to monitor the network through DSE and take corrective actions close to real-time. Due to communication delays and computation time for the convergence of the algorithm, the time-step of this control algorithm is set to 10 min. The prediction horizon is set to 1 hour (6 time-steps) to synchronize with the hourly schedule of the day-ahead market. The simulation scenario is setup as follows with artificial high loads in the MV network to create network congestions. During evening (8 pm) when the demand in the MV network is at its peak, the branch power flow between MV bus M21 and M22 exceeds the limit by 5% and the voltage at the LV network connected to M22 drops less than the allowed limit of 0.9 pu. The LV transformer has a manual tap changer but it is not helpful to regulate the voltage at nodes R1 to R5 in real-time. The DSE detects the congestion at branch M21-M22 to be 105 % based on the estimated system state (V_n, P_b) and sends the information to the CMO. Based on the system state (V_n, P_b) and updated forecasting

information (\hat{P}_g, \hat{P}_d) , the CMO algorithm computes the aggregated flexibility ($\Delta P_g = 0$ as there is no PV power generation during night required and $\Delta P_d = 0.8$ MW) at M22 by solving (5) to (18) and sends the flexibility information to the area controller of bus M22. The area controller of M22 computes the power setpoints of the flexible loads at MV bus M22 to be 0.6 MW and the flexibility at LV nodes R1, R3 and R6 to be 0.2 MW, thereby alleviating the congestion at branch M21-M22 and under-voltage at the LV nodes. In this assumption, the ramp rate limits of the DRR are not considered and it is assumed that the flexible loads can respond to the consumption change request within 10 min. The voltage profile of the LV network without and with flexibility estimated by the CMO and realized by the M22 area controller are shown in Fig. 9.

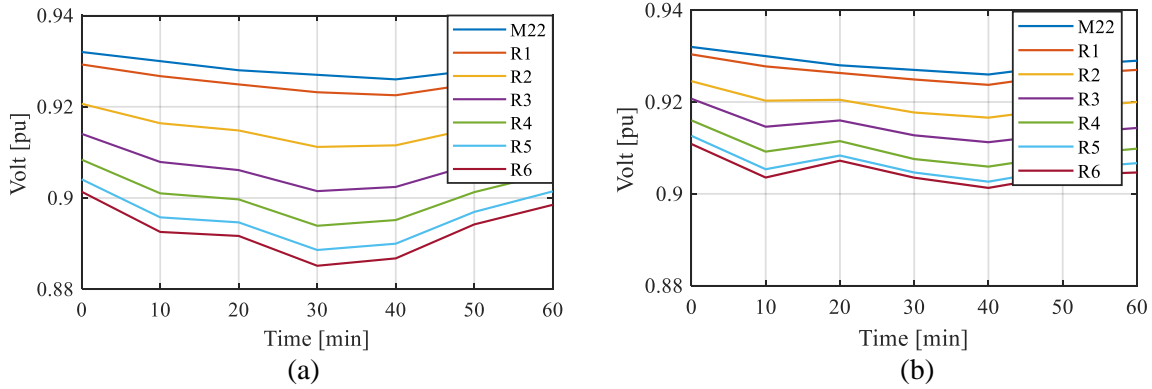

Fig. 9. Voltage profile of LV network at MV bus M22 (a) without flexibility (b) with flexibility

As seen in Fig. 9, the flexibility computed by the CMO algorithm and the corresponding activation of the flexible loads at M22, R1, R3 and R6 by the area controller improves the voltage profile as an additional benefit along with removal of network congestion at branch M21-M22.

VI. Discussions

The proposed method for network congestion management operates in two time frames. The planning phase of the CM called CMP is interfaced with the day-ahead market. The operating phase of the CM called CMO is coordinated with the intraday market, the area controllers of each MV bus, and the flexible assets at MV and associated LV buses. The backbone of the CM is the forecasted load/generation and the estimated system state. The proposed method is helpful for the DSO in future grid scenarios to handle network congestions. Further studies are required for the real-time implementation of the proposed method in MV grids. The communication infrastructure of the grid has to be upgraded for the reliable and timely transmission of information among various modules in the proposed CM algorithm. The proposed CMP and CMO algorithms along with observability modules can be implemented as modules in the DMS located in the control center of the DSO. The area controllers discussed in this work are the secondary substation controllers, which can be located at the (MV/LV) secondary substations. The DER and DRR aggregators are the commercial aggregators of flexible assets participating in the electricity markets, whereas the area controllers act as technical aggregators and send the physical control signals (power setpoints) to each DER/DR device at the prosumer site. In our future work, a reduced scale test setup of the MV grid will be implemented in a real-time digital simulator for studying the combined operation of the state estimation and control algorithms in detecting and resolving the simulated network congestions.

VII. Conclusions

This paper addresses network congestion problems in MV distribution grids due to high penetration of renewables. To manage network congestions, a novel method for forecasting and dynamic state estimation and coordinated control based on MPC are proposed for overall network optimization. The proposed method estimates the amount of flexibility to be bought from the day-ahead electricity market to solve the network congestions. The main contributions of this paper are (i) improved observability

and better state estimation of the network with more robustness and less measurements (ii) an optimal control method to solve the network congestions by planning and operation, (iii) utilization of flexibility in the network assets to minimize the costs of network operation, (iv) enhancement of system stability and reliability. The proposed method is validated for few test cases through simulations of a model of a Danish MV distribution network. The obtained results is applicable to solve practical network congestion problems for distribution network grids with radial topology. Verification of the proposed method in the field is a part of the future work.

BIBLIOGRAPHY

- [1] P. Pinson, L. Mitridati, C. Ordoudis and J. Ostergaard, "Towards fully renewable energy systems: Experience and trends in Denmark," in *CSEE Journal of Power and Energy Systems*, vol. 3, no. 1, pp. 26-35, Mar. 2017.
- [2] Papathanassiou, S., et al. "Capacity of Distribution Feeders for Hosting DER." *CIGRE Working Group C6. 24. Tech. Rep.* 149, 2014.
- [3] Xu, Zhao, et al. "Towards a Danish power system with 50% wind—Smart grids activities in Denmark." *IEEE Power & Energy Society General Meeting*, 2009.
- [4] Haque, A. N. M. M., et al. "Congestion management in smart distribution network." *Power Engineering Conference (UPEC), 2014 49th International Universities*. IEEE, 2014.
- [5] Q. Chen, D. Kaleshi, Z. Fan, and S. Armour, "Impact of Smart Metering Data Aggregation on Distribution System State Estimation," *IEEE Trans. Ind. Informatics*, vol. 12, no. 4, pp. 1426–1437, 2016.
- [6] S. W. Alnaser and L. F. Ochoa, "Advanced Network Management Systems: A Risk-Based AC OPF Approach," in *IEEE Trans. on Power Systems*, vol. 30, no. 1, pp. 409-418, Jan. 2015.
- [7] A. Kulmala *et al.*, "Hierarchical and distributed control concept for distribution network congestion management," in *IET Generation, Transmission & Distribution*, vol. 11, no. 3, pp. 665-675, 2 16 2017.
- [8] R. A. Jabr, B. C. Pal, and R. Singh, 'Choice of estimator for distribution system state estimation', *IET Gener. Transm. Distrib.*, vol. 3, no. 7, pp. 666–678, 2009.
- [9] A. Abur and F. H. Magnago, 'Optimal meter placement against contingencies', in *2001 Power Engineering Society Summer Meeting. Conference Proceedings*, 2001, pp. 424–428, 2001.
- [10] H. S. Hippert, C. E. Pedreira, and R. C. Souza, 'Neural networks for short-term load forecasting: a review and evaluation', *IEEE Trans. Power Syst.*, vol. 16, no. 1, pp. 44–55, 2001.
- [11] N. Amjady, 'Short-term hourly load forecasting using time-series modeling with peak load estimation capability', *IEEE Trans. Power Syst.*, vol. 16, no. 4, pp. 798–805, 2001.
- [12] J. Yokoyama and H. D. Chiang, 'Short Term Load Forecasting improved by ensemble and its variations', *IEEE Power Energy Soc. Gen. Meet.*, 2012.
- [13] H. Quan, D. Srinivasan, and A. Khosravi, 'Short-term load and wind power forecasting using neural network-based prediction intervals', *IEEE Trans. Neural Networks Learn. Syst.*, vol. 25, no. 2, pp. 303–315, 2014.
- [14] D. K. Molzahn, F. Dörfler, H. Sandberg, S. H. Low, S. Chakrabarti, R. Baldick, and J. Lavaei, 'A Survey of Distributed Optimization and Control Algorithms for Electric Power Systems', *IEEE Trans. Smart Grid*, vol. 8, no. 6, pp. 2941–2962, 2017.
- [15] M. E. Baran and F. F. Wu, 'Optimal sizing of capacitors placed on a radial distribution system.', *IEEE Trans. Power Deliv.*, vol. 4, no. 1, pp. 735–743, 1989.
- [16] H. S. Bidgoli, 'Model predictive control of congestion and voltage problems in active distribution networks', *CIGRE Work. - Rome , 11-12*, no. June, pp. 11–12, 2014.

Publication: C6

(Conference Paper)

Improved TSO - DSO Interoperability and their cooperation in smart grid

Basanta Raj Pokhrel, N. Karthikeyan, Birgitte Bak-Jensen, Jayakrishnan R. Pillai, A. Jensen,
J. Andreasen, T. Helth, and K. H. B. Frederiksen

This paper is published in CIGRE Symposium Aalborg, 2019.

Conference Link: <https://cigreaalborg2019.dk/>

Improved TSO - DSO Interoperability and their cooperation in smart grid

**Basanta Raj POKHREL^{1*}, Karthikeyan NAINAR¹, Birgitte BAK-JENSEN¹,
Jayakrishnan R. PILLAI¹, Allan JENSEN², Jacob ANDREASEN³, Thomas HELTH⁴,
Kenn H. B. FREDERIKSEN⁴**
**¹Aalborg University, ²Eniig A/S, ³Syd Energi A/S, ⁴Kenergy
Denmark**

SUMMARY

The energy scenario is experiencing substantial change due to increasing displacement of conventional forms of generation at transmission network level by renewable energy sources (RES) at distribution level. At the same time, consumers have started to participate in the electricity market as prosumers (both producer and consumer) or demand side response (DSR) entities. These partly fluctuating RES and DSR units at distribution level will change the behaviour of entire system, challenging the balance of load and generation in the grid at all time. Obviously, each distribution/transmission system operator is responsible for its own grid only, but to operate the grid properly in the new emerging scenario, it is important to know what is happening in part of the surrounding grids too. The Transmission system operator (TSO) has the primary responsibility of grid balance but it has no direct control over RES and DSR at distribution grid as of today. In general, TSOs also do not have the desired observability levels of relevant components of the distribution network such as medium voltage lines, substations etc. In future, TSOs using traditional observability analysis approach, as a fundamental tool to ensure system security, might be at risk. From a DSO (distribution system operator) perspective, the use of transmission system's observability information has always been very limited and unnecessary until now. However, in the new scenario, the information exchange between TSOs and DSOs allows them to utilize the increasing penetration of DERs and DSRs more effectively providing ancillary service and local control. This trend is expected to grow more in future so it demands revision of the traditional way of TSO - DSO interaction. This work will explore the current practice of interaction between TSOs and DSOs, investigate the specific grid operation challenges, and identify the possible future ways of cooperation in smart grid. The analytical analysis in European perspective considering Denmark as an example is presented.

KEYWORDS

TSO-DSO interface, interoperability, grid congestion, ancillary services, observability area, information exchange.

I. Introduction

The European Union (EU) is targeting for a 100% renewable based energy system by 2050 and 20% by 2020 [1], [2]. To support this EU initiative, all countries in EU have setup their respective milestones. As an example, Denmark has an ambitious milestones to meet 50% of electricity production from wind by 2020 and 100% energy consumption (heating, electricity including transport) to be meet from RES by 2050 [3]. The International Renewable Energy Agency (IRENA) have evaluated EU energy prospectus in its latest RE map (Renewable energy map) report. REmap program determines the potential for individual countries and regions to scale up renewables. Summary of renewable energy prospects for the EU is given in Fig. 1 [2].

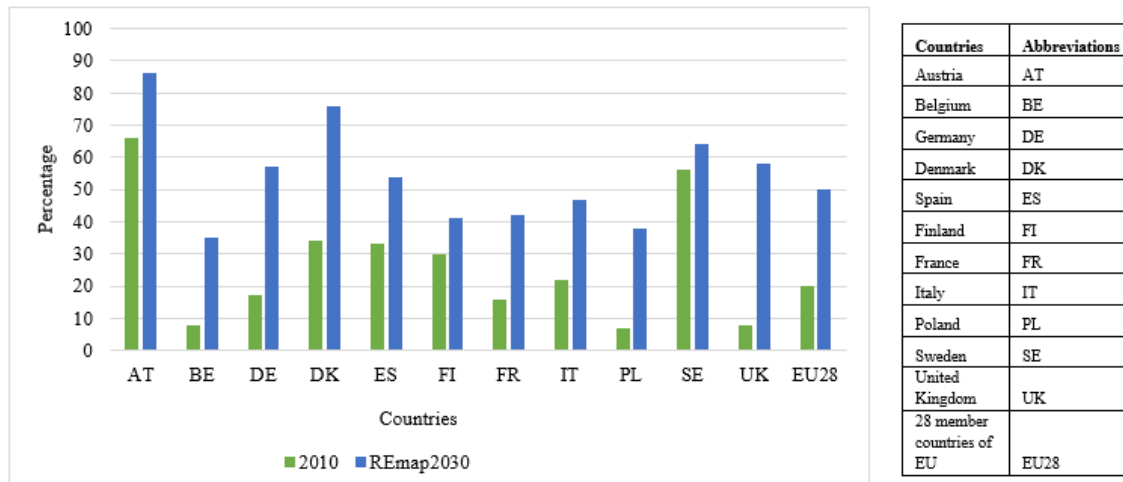

Fig. 1 RE Share in electricity generation in EU

Fig. 1 shows the percentage of renewable energy in total energy generation in the countries in EU in 2010 and compare it with REmap 2030. The fundamental way of power system planning and operation is changing due to this new strategy to move towards a more sustainable energy system, in which REs and electricity consumer's role is kept in center [4], [5]. In this regard, an efficient exchange of power between individual countries becomes even more important in systems with high penetrations of variable renewables. The capacity to export and import power is a key source of flexibility to the power system, allowing the integration of larger volumes of REs by attenuating their inherent variability into a larger power system. The EU can double the share of REs from 17% in 2015 to 34% in 2030 in its total energy mix [2] if the right frameworks are put in place to allow more REs [6], [7]. In fact, the traditional distribution network managed by DSO is mostly passive, demand is nonflexible and Distributed Generation (DG) is operated with a fit-and-forget approach. However, in the changing situation, DSOs are expected to manage active networks. In addition, other anticipated activities are to support local balancing; active interaction with Transmission System Operators (TSOs), optimum utilization of available distributed energy resources (DER) and controllable network assets; and preserve system integrity and stability. Therefore, new operational options to ensure a required flexibility seen in relation to also an increased TSO/DSOs/market coordination have to be investigated. It will enhance the Active Distribution System Management (ADSM) for preventive actions rather than corrective actions.

More specifically, the electricity scenario is experiencing a significant change due to emerging trend of increasing penetration of renewable based distributed generation (DG) at distribution grid level replacing conventional generators at transmission grid level. This is supported by the behavioural change of the customer, because they have started to participate in the market either by becoming prosumers (consumer as well as producer) or by engaging in DSR activities. Challenges due to change in the electricity scenario can be categorized in to three groups: (i). Availability and application of huge data due to presence of new actors (smart meters, aggregators, retailers, BRP: balance responsible parties etc.) in the system, (ii). Commercial interaction of these actors that leads to the new market framework and (iii). Technical challenge in the grid management due to an active distribution

network with more fluctuation generations (E.g.: Congestion, voltage/frequency fluctuation, grid balance, protection/control, islanding etc.). These challenges are not only for distribution grids but also for the whole electricity network operation. It will change the behaviour of the whole system making it more challenging for the TSO not only for balancing generation and load but also for grid control and protection at all time. Key criteria to handle these challenges are optimal use of resources, vibrant rules for competition, ensured customer confidentiality and reasonable and reliable allocation of price [8]. This work focuses on greater operational interaction between TSO – DSO in future grid considering above-mentioned challenges. This paper will describe the emerging scenario of stakeholders interaction in the electricity system and investigate the current practice and problems in TSO-DSO interaction. Then it will describe the key issues like data handling, the dimension of markets, network planning and system operations during TSO – DSO interaction in Denmark as a case study. An analytical method will be used to discuss aforementioned issues and define the observability areas of both TSOs and DSOs to identify which points of the distribution and transmission grids will be considered in the process of exchanging information. As an example, findings of this study can be beneficial to TSO and DSO to address technical problems like congestion management and exchange of ancillary services in their respective grids in future. Finally, it will formulate the guidelines and recommendations that can serve as a foundation for discussion between the stakeholders in this domain.

II. Stakeholders interaction in electricity system

General interaction within the major stakeholders in the electricity system for traditional and emerging electricity systems are shown in Fig. 2 and Fig. 3 respectively. As shown in Fig. 2, TSO has a major role and control in the traditional system for grid operation. It has required flexibility in its own grid due to connection of big consumers and most of the generation placed at transmission network level. Also, in most of the cases the TSO have the dominant role in market operation. Wholesalers and Generation companies are the only major market participants and retail market for consumers exists in Europe from 2011 [9]. Distribution grids are mostly passive and have no flexible resources in their grid. So, there used to be very limited interaction between TSO and DSO in the traditional system. However, this will not be true in the emerging scenario. As shown in Fig. 3 flexibility available at transmission grid is shifting to distribution grid and new actors are participating in the market. The value of a specific flexibility service is also not the same at TSO level and at DSO level respectively. Therefore, it is not straightforward for the TSO to balance its grid and coordinate with market. So a clear procedure and a strong coordination is needed [7].

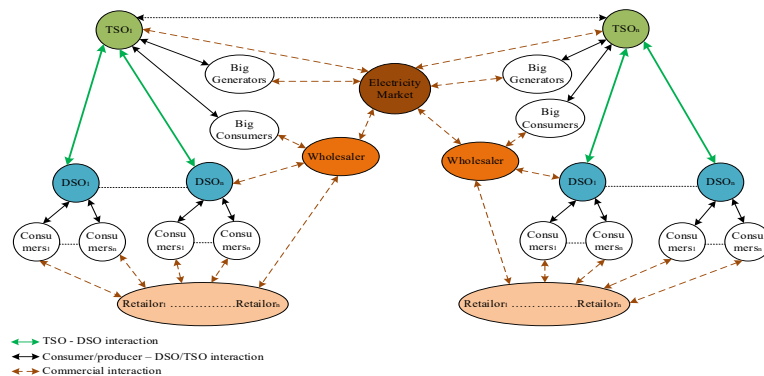

Fig. 2 Stakeholders interaction in traditional electricity system

As we can observe from Fig. 3, TSO-DSO cooperation and interoperation ability is one of the frameworks, which has to be upgraded and enabled for efficient operation in future because not only flexible resources are increasing at distribution level but also participating in the market too. In this transformation, two important actors in facilitating the transition to cleaner and secure energy have been the TSOs and DSOs. To achieve the energy target in the emerging scenario, TSOs and DSOs contribution is expected to be crucial due to new challenges they may face such as high penetration of renewable based DGs. This will enhance their responsibilities more demanding to fulfil. Apart from

the unbundling cases where TSOs and DSOs operate at national level, it is likely to expect TSOs and DSOs handling new responsibilities and roles in different ways throughout the region in future [10].

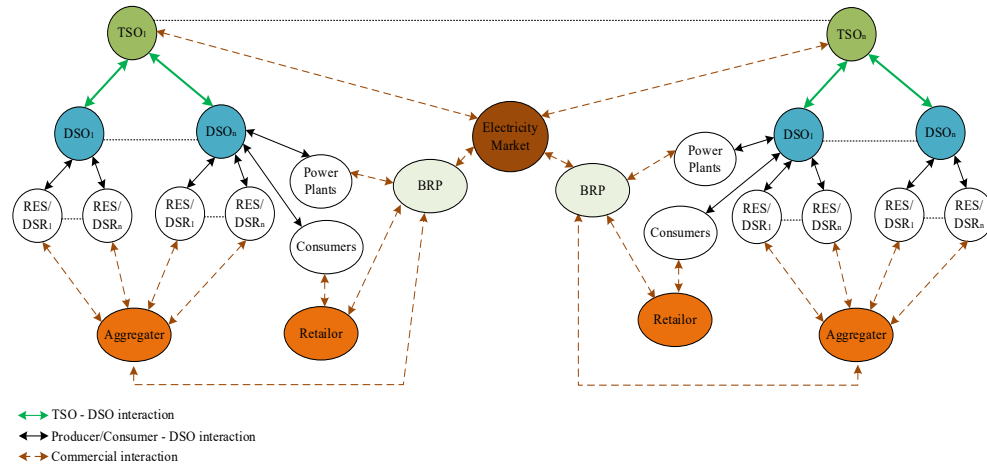

Fig. 3 Stakeholders interaction in emerging electricity system

III. Specific grid operation challenges in emerging electricity system

Emerging trend of increasing volume of partly fluctuating generations at distribution grid replacing less fluctuating conventional generators at transmission grid is challenging network operators to balance generation and demand at all time. Challenges that are related to TSO-DSO interaction are handling of huge data, interaction of stakeholders in new market setup, and handling of technical issues (E.g.: congestion of interfacing transformer and line, voltage support, balancing the grid, islanding etc.) [11]. These may be different for different network configuration and operation scenarios. Description of some generic grid operation challenges and the concerns in TSO-DSO interface are described in Table 1.

Table 1 General grid operation challenges that concern TSO-DSO interface

Grid operation challenges	Description	Concern in TSO-DSO interface
Data security and handling	<ul style="list-style-type: none"> Huge data will be available due to smart meters, RTUs/PMUs, load/generation forecasting of distributed consumers and producers etc. 	<ol style="list-style-type: none"> Who will take ownership of these data? How individual's privacy can be guaranteed? Are there any guidelines for data exchange between TSO and DSO? How to identify which data are beneficial for each other (TSO and DSO)?
Operation in new market setup	<ul style="list-style-type: none"> Market should be fully liberalized to host increasing DG/RES/flexible loads at distribution grid. Due to this, new participants like aggregators, prosumers, BRPs, retailers are emerging in the new scenario. 	<ol style="list-style-type: none"> What is the best market structure in new scenario? Is the market fully liberalized? If yes, how each market participants are interacting with each other and how they are linked with TSO and DSO? What commercial information is exchanged between TSO and DSO? Is both transmission and distribution capacity limitation considered between market zones?
Congestion of TSO-DSO interfacing transformer and transmission line respectively	<ul style="list-style-type: none"> Interfacing transformer is more likely to be overloaded due to increasing DG/RES/loads at distribution grid. If this transformer is not owned by DSO, they have to communicate to TSO in this situation. Overloading of transmission line, which can happen due to overloading of many interfacing transformer and TSO's own customers. 	<ol style="list-style-type: none"> Who owns this transformer? TSO or DSO If owned by TSO, and in case of congestion, how communication happens? Manually by phone or automatically? Does TSO sends signals directly to feeders for disconnection? Does TSO communicate to the DSO before disconnecting interfacing transformer to avoid transmission line congestion? Is possible congestion avoided in planning phase and later it never happens? Example: applying n-1 criteria? Is TSO-DSO interfacing area fully observable using network state estimation and forecasting of loads/generations? Are there any control measures at TSO-DSO interfacing area to utilize the flexibility available there?
Challenges in Power balancing	<ul style="list-style-type: none"> Difficulties in balancing the grid due to fast fluctuating generation and consumption. 	<ol style="list-style-type: none"> Are generators and loads from DSO network participating in balancing market? Is DSO involved in prequalification processes related to ancillary service from the loads and generation at distribution network?

		<ul style="list-style-type: none"> iii. Real time balancing platform exists or not? iv. Are smart meter data measured by DSO used for flexibility assessment and communicated to TSO? v. There is possibility for TSO to balance its grid by having bilateral contract for flexibility from generator or loads. Is DSO involved somewhere or not?
Voltage support on both transmission and distribution network	Using flexibility on distribution grid and tap setting of interfacing transformer both DSO and TSO can support the voltage at each other's network respectively.	<ul style="list-style-type: none"> i. Voltage control on Transmission network: Does DSO support voltage at TSO lines by activating flexibility on distribution grid. If yes, how it is communicated? ii. Voltage control on Distribution network: Does DSO control voltage level with TSO-DSO transformer tap setting at distribution grid? If yes, and transformer is owned by TSO how communication happen?
Interoperability Challenges for coordinated protection	In case of faults in transmission grid, alarms can be seen in the distribution system and even force to trip the distribution grid component and vice versa.	<ul style="list-style-type: none"> i. Are there any interaction between DSO and TSO for coordinated protection? ii. If yes, are there real time data exchange for this? iii. Do DSO's protection system receive any settings from TSO or vice versa iv. Are there any guidelines or protection policy available and implemented as of today for TSO-DSO data exchange in particular area ?
Challenges during Islanding at TSO-DSO interfacing area, re-synchronization and black start	Islanding: Technically zero power flow from TSO-DSO interfacing transformer; detection of such situation, re-synchronization and balancing after that.	<ul style="list-style-type: none"> i. Are there regular exercise with participation from both DSO and TSO? ii. If yes, what type of data are exchanged (human interaction or automatic?) for island detection, re-synchronization and balancing

IV. Current practice of TSO-DSO interaction

General status of TSO – DSO interaction in Europe and specifically in Denmark has been identified. It is evaluated based on the literature review, survey of network operators, and interaction during project meetings with project partners Energinet.dk (the Danish TSO), Energi and SE (Danish DSOs), Kenergy (Energy consultant) and ABB [11], [12], [13], [14], [4], [7], [15], [16], [17]. The main objective here is to identify how network operators are handling grid operation challenges that are discussed in section III and to make necessary recommendation for future smart grid operation scenario. To have efficient operation and planning, TSO-DSO can share specific information (E.g.: operation schedule, forecasted load/generation, grid data, flexibility data etc.) with each other via data exchange platforms (DEP). In most of the countries in Europe, DEPs are in operation except in Germany [18]. But their ownership and operation is not in similar manner. In countries like Denmark, Estonia, Norway it is owned and operated by the TSO (operated by subsidiary company of TSO in Norway). Where as in Belgium and Ireland, DEP is owned by DSO and in Italy it is owned by both TSO and DSO but is operated by a third party in all these three countries [18]. Market structure is not country specific like data handling, mostly it is regional (E.g.: Epexspot, Nord Pool, etc. in Europe). Epexspot covers France, UK, Germany, Netherlands, Belgium, Luxembourg, Austria and Switzerland [19]. Denmark is a participating in Nord Pool electricity market; it not only covers Scandinavian countries but also Baltic countries and UK too. This is the world's first electricity market to liberalize both generation and retail [20]. These electricity markets consists of both day ahead market settlement and balancing mechanism and provide intraday trading in the European region. Due to inherent regional characteristics of these markets, only transmission capacity limitations are considered during the settlement [20]. Generally, fluctuating REs like wind are participating on day ahead market based on fixed price for generation (i.e. feed-in-tariffs). However, increasing high share of fluctuating REs are putting pressure to downstream wholesale price due to their low marginal cost. In Denmark, to minimize the impact and accommodate more REs two price based imbalance settlement is used [20]. In this case only the generators who is contributing to the system imbalance is subject to pay the penalty but if it's over production can be utilized due to increased load at that particular time then it will not be penalized and get same price as agreed before. As of today, only TSO is involved in this market clearing process. After the settlement of market, hourly operation schedule is shared to TSO only and commercial information exchange between TSO-DSO is very limited.

Regarding technical issues, in most of the countries, interfacing transformer and transmission line congestion are avoided in planning phase by the n-1 criteria and cooperation is made during planning

phase [11]. In most of the cases the TSO is responsible for control of supply and demand. Disconnecting of feeders and load is performed manually or automatically, it depends on the situation. Generally, DSOs are not seen involved in grid balancing activities, TSO takes care of it but in some cases distribution costumers are taking part in balancing with partial involvement of the DSO. For voltage support, TSO is supporting the DSO by tap changing in the interfacing transformer and reversely capacitor banks installed in the distribution grid are supporting TSO [11]. In some cases DGs can be found supporting voltage due to grid code for Volt-Var control [11]. If islanding of the network is detected by a defined algorithm, the DG is disconnected and black start is carried out in close cooperation. However, coordination in protection is still seen limited in most of the cases. Summary of current TSO-DSO interaction in Denmark (Energinet.dk and Eniig) is given in Table 2.

Table 2 Summary of current TSO-DSO interaction in Denmark [12], [13], [14] [17]

TSO-DSO Interaction for	Current practice in Danish case
Data Handling	<ul style="list-style-type: none"> • TSO operates the Data hub and owns it in accordance with the applicable legislation under Danish act under the processing of personal data. • Any grid company/DSO can access the data under certain terms and condition and are obliged with market regulations.
Operation in new market structure	<ul style="list-style-type: none"> • Denmark is participating in Nord pool market. Only transmission capacity limitations are considered in the market settlement. • Only TSO is involved in market clearing process and get the hourly operating schedule from the market. • New stakeholders like BRPs, aggregators and retailers are emerging mostly at DSO level.
Congestion of TSO-DSO interfacing transformer	<ul style="list-style-type: none"> • Interfacing transformer is 150/60 kV and is owned by TSO but 60 kV circuit breaker at this transformer station is controlled by DSO. In case of congestion, communication (regarding frequency) are automatic. • Mostly n-1 contingency analysis is carried out in planning phase.
Transmission line congestion	<ul style="list-style-type: none"> • TSO communicates to the DSO before disconnecting interface with DSO to handle the line congestion. • Although some level of analysis is carried out during planning phase still transmission lines are overloaded in many situation.
Grid balancing	<ul style="list-style-type: none"> • Generators and loads in DSO networks are participating in balancing market and are controlled by TSO. • DSO is not involved in prequalification, TSO takes care of this. • Consumer flexibility is not assessed by real metering data measured by DSO. It is done by data hub. • DSO is not involved in the bilateral contract between TSO and generators or loads at distribution grid. TSO is balancing its grid based on this contract.
Voltage support on both TSO-DSO side	<ul style="list-style-type: none"> • DSO helps TSO for voltage support by reducing its load at the step of 10%. • TSO helps DSO for voltage support by changing the taps in the interfacing transformer. It is communicated via SCADA system of TSO.
Interoperability for real time control and coordinated protection	<ul style="list-style-type: none"> • Some level of communication and real time data exchange is carried out via SCADA. • Communication standards and protocols for this data exchange are available.
During islanding, re-synchronization and black start	<ul style="list-style-type: none"> • Regular exercise to avoid possible hazard due to islanding have been carried out by TSO with the participation of DSO.

V. New dimensions of TSO-DSO interface

Based on the above presented scenario and discussion, the dimensions of TSO-DSO interface and interoperability can be broadly categorized in to non-technical and technical clusters. Here, handling of huge data available in the emerging scenario and interlink of commercial stakeholders in the new market set up is grouped as a non-technical dimension. Whereas TSO-DSO interface and coordination required during network planning phase as well as in system operation and control is grouped as a technical dimension. These dimensions are interlinked to each other for example data collection and handling can be either from planning perspective or from real time system operation perspective [21]. Brief description of these dimensions are given in Table 3 below.

Table 3 Description of new dimensions of TSO-DSO interface [6] [15], [20], [21], [22]

Cluster	Dimension of TSO-DSO interface	Descriptions	Remark
Non-technical	Data handling	<ul style="list-style-type: none"> More data will be required in the emerging scenario for enhanced operation that enables consumers participation (i.e. entry of aggregators and DSR activities), improve network observability and real time control. These data can be available from smart meters and new stakeholders in the market (Aggregators, BRP etc.) 	<ul style="list-style-type: none"> Collection of real time data from each small scale RES/DG/DSR for TSO and DSO will be difficult or more costly. Framework to identify required data type, its quality and ownership has to be put in place by TSO and DSO jointly. It should also guarantee the security and privacy of data. It will simplify the processing of huge data and help to maintain fair market competition.
	Market framework	<ul style="list-style-type: none"> In the traditional market set up TSOs are not involved in retail market. In the new set up TSO's involvement in retail market is necessary because prosumers or DSR entity at DSO network are participating in market and are also providing system services like balancing, frequency response etc. which are needed by TSO. Therefore, clear and defined roles and responsibility of TSO and DSO are now important whatever the market framework be. 	<p>Based on individual stakeholders' coordination pattern some conceptual market framework that can be used in emerging scenarios are identified as:</p> <ul style="list-style-type: none"> Improved traditional framework: One TSO operated ancillary service market for resources available at both TSO and DSO network. Here, DSO is not involved in market settlement process and its constraints are not considered too. Separate market framework: DSO operates separate market for resources connected to its own network and can offer the aggregated bids to TSO operated market only after solving the local grid constraints at DSO level. Shared framework for balancing: TSO and DSO share the responsibility of network balancing. However, they balance their respective network using own resources only in their respective market where their respective constraints are considered. One flexibility market framework: One market for all resources in the system (both TSO and DSO). Operation could be single or integration of TSO operated market and DSO operated market in real time. Both DSO and TSO constraints are considered. Combined flexibility market framework: Single common flexibility market but operated by separate independent operator (not TSO and DSO). Resources allocation based on price. DSO constraints are considered.
Technical	Network planning	<ul style="list-style-type: none"> Traditional planning approach may not enable the potential of prosumers/DSR/RES connected to distribution grid for system services (congestion management, voltage support etc.). Provision of only grid connection facility for DGs at DSO network may not be sufficient in future. 	<ul style="list-style-type: none"> Integrated planning approach where TSO and DSO should interact from planning phase is necessary. DSO's knowledge in local and regional level demand and generation harnessing will be crucial information for system expansion planning in new scenario, which demand regular interaction and exchange of information between TSO and DSO for system planning purpose.
	System operation and control	<ul style="list-style-type: none"> Increasing RE based generation at DSO network replacing conventional generators at TSO network. Even in new scenario, TSO will have main responsibility for balancing, frequency control and system restoration whereas DSO will manage its own network congestion and voltage management. 	<ul style="list-style-type: none"> To utilize the DG/DSR's capability for ancillary service, proper operational setup is required to minimize the scarcity of system service at TSO network. Enhanced observability of DG/DSR connected to the DSO operated network and defined observability reach of both TSO and DSO with sufficient overlap as shown in Fig. 4 is required. It will improve the security of supply, minimize the impact of forecast error also help to limit the reserve margin due to uncertainty.

VI. Observability of TSO/DSO interfaces

Each network operator is responsible for its own network so in general they can observe only its own area. However, to operate grid properly in emerging scenario observability of its own grid will not be sufficient. It will be crucial to know what is happening in the near by network. By defining the observability area, grid operators' observability reach can be significantly enhanced beyond their own network. Responsible area consisting of own grid as well as part neighbouring grid is known as observability area [4]. The concept of observability area in a Danish scenario is illustrated in Fig. 4.

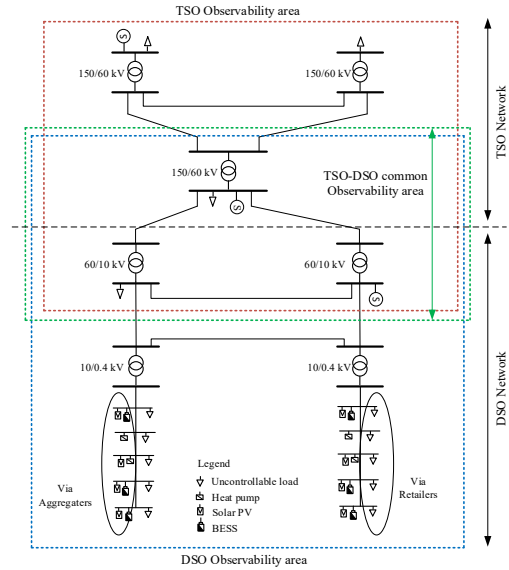

Fig. 4 Defined observability area for TSO and DSO interface in Danish scenario

Common observability area is more important in TSO-DSO interface where it may be required for them to exchange more intense data related to their own network as well as significant grid users in that area. Here, intense data is referred as estimated or measured network state, forecasted profile of load and generation etc. that can be embedded to advanced distribution management system (ADMS) and also communicated to TSO-SCADA. For the network outside the common observability area, the exchange of only limited information may be sufficient for example, information about amount of flexibility available at distribution network may be sufficient for TSO. It can be collected from aggregators. In this case, TSO may not need network data from the distribution grid.

VII. Recommendations for smart TSO-DSO interactions

From above discussion and scenarios presented, though some trend of interaction between TSO and DSO are evolving they are not sufficient for future energy landscape. This gap can be fulfilled by extending present interaction and implementing some new strategies. These are described in Table 4 below. It is seen that DSO roles and responsibility will be magnified compared to TSO as it has to carry out two-way communication with TSO, DSR entities at distribution network as well as data and flexibility management. On top of it, DSO should also put in place the real time grid monitoring mechanism via ADMS and has to interface it with the TSO- SCADA system.

Table 4 Recommendation for TSO-DSO interaction in smart grid operation

S.N.	Interaction for	Recommended strategy for future
1	Data handling	<ul style="list-style-type: none"> Security of data (e.g.: customer consumption history data recorded via smart meter) can be guaranteed by an independent Data hub center under the ownership of public entities not within TSO or DSO. DSO can share the estimated/measured network status from the selected interfacing area to TSO and vice versa.
2	Market strategy	<ul style="list-style-type: none"> Since the distribution grid is becoming more active, considering distribution system limitation too in market settlement will increase the system operation reliability. In addition, DSO involvement in market clearing process can help DSO to balance its network locally and reduce the stress on TSO. For this, either TSO should share the operation schedule received from market to DSO or market should also have direct communication with DSO. More liberalized local market is another possibility where power can be utilized locally in DSO responsible area by operating DSO operated local market. In this case, resources can be traded locally and they can contact upper market (regional market) only for excess load or excess generation or for balancing purpose.
3	Congestion management (interfacing transformer and transmission line)	<ul style="list-style-type: none"> More relevant and detailed data exchange within the common observability area that will increase the flexibility use and reduce the transformer loading. DSO can send the flexibility information collected from aggregator to TSO. TSO can analyse and use flexibility available at distribution network to minimize transmission line congestion. Prioritization technique can be used to select the flexibility available in transmission and distribution network respectively.
4	Network balancing	<ul style="list-style-type: none"> DSO can take part in grid balancing via aggregator DSO can take the role of local network balancing

		<ul style="list-style-type: none"> Overlapping should be avoided between flexibility trading signals (commercial signals) with network operation signals using flexibility otherwise it will miss lead the operation.
5	Voltage support	<ul style="list-style-type: none"> Reactive power from DG can be used for TSO voltage support in a coordinated manner. Existing capacitor banks at DSO network can be used for TSO voltage support. TSO-DSO can agree on specific set points for reactive power/power factor/voltage at interfacing point.
6	Coordination in real time control and protection	<ul style="list-style-type: none"> Exchange the measured/estimated network data for protection for quick localization of fault.
7	Islanding detection and black start	<ul style="list-style-type: none"> Share the DG/RES production forecasted so that TSO can use these units for grid restoration

VIII. Conclusions

In this paper the current practice of network interaction are discussed, specifically TSO-DSO interaction. Three aspects of challenges are categorised, namely data handling, market setup and technical issues for the emerging scenarios in power systems (increasing RE penetration at distribution level and decreasing conventional generators at transmission level). Due to the replacement of conventional generators at TSO grid by RE based generators at DSO, grid challenges are emerging not only for ancillary service management but also for system operation. It is discussed and recommended that these challenges can be converted to opportunities to certain extent by redefining data management, proper exchange of data between TSO-DSO (not only technical but also commercial), restructure of market setup and by revising the strategy to handle technical problems.

BIBLIOGRAPHY

- [1] D. Connolly, H. Lund, and B. V Mathiesen, "Smart Energy Europe: The technical and economic impact of one potential 100% renewable energy scenario for the European Union," 2016.
- [2] IRENA, "Renewable Energy Prospects for the European Union," 2018.
- [3] E. and B. Danish Ministry of Climate, "Smart Grid Strategy," vol. 5, no. May, pp. 31–33, 2013.
- [4] "Coordination of Transmission and Distribution data eXchanges for renewables integration in the European marketplace through Advanced, Scalable and Secure ICT Systems and Tools | Projects | H2020 | CORDIS | European Commission." [Online]. Available: <https://cordis.europa.eu/project/rcn/211959/factsheet/fr>. [Accessed: 14-Jan-2019].
- [5] M. Bollen and F. Hassan, *Integration of Distributed Generation in the Power System*. Hoboken, NJ, USA: John Wiley & Sons, Inc., 2011.
- [6] A. Saint-Pierre and P. Mancarella, "Active Distribution System Management: A Dual-Horizon Scheduling Framework for DSO/TSO Interface under Uncertainty," *IEEE Trans. Smart Grid*, vol. 8, no. 5, pp. 2186–2197, 2017.
- [7] H. Gerard, E. I. Rivero Puente, and D. Six, "Coordination between transmission and distribution system operators in the electricity sector: A conceptual framework," *Util. Policy*, vol. 50, pp. 40–48, 2018.
- [8] R. Alves, F. Reis, and C. Liang, "TSOs and DSOs Collaboration: The Need for Data Exchange," *TRIVENT Eng. Ind. Ser.*, vol. Deregulate, 2015.
- [9] Council of European Energy Regulators, "Retail Markets Monitoring Report CEER Report Ref: C17-MMR-83-02," 2017.
- [10] Nordisk Ministerråd and Nordisk Råd, *Coordination of network operations and system responsibility in the Nordic electricity market*. Nordisk Ministerråd, 2006.

- [11] A. Zegers and H. Brunner, “TSO-DSO interaction: An Overview of current interaction between transmission and distribution system operators and an assessment of their cooperation in Smart Grids,” 2014.
- [12] “Energinet.dk - Electricity.” [Online]. Available: <http://energinet.dk/EN/ANLAEG-OG-PROJEKTER/Sider/default.aspx>.
- [13] “New Annual Report for 2017.” [Online]. Available: <https://eniig.dk/privat/om-eniig/profil/aarsrapporter/>. [Accessed: 16-Jan-2019].
- [14] “SE Energi.” [Online]. Available: <https://www.se.dk/>. [Accessed: 16-Jan-2019].
- [15] G. Migliavacca, M. Rossi, D. Six, M. Džamarija, S. Horsmanheimo, C. Madina, I. Kockar, and J. M. Morales, “SmartNet: H2020 project analysing TSO–DSO interaction to enable ancillary services provision from distribution networks,” *CIREN - Open Access Proc. J.*, vol. 2017, no. 1, pp. 1998–2002, 2017.
- [16] W. H. Wellssow, R. Brandalik, M. Weisenstein, H. Ma, A. K. Marten, T. Gomez, J. P. Chaves, G. C. Zweigle, Y. Li, and Y. Krause, “Situational awareness and control of distribution systems and interaction with transmission systems,” *20th Power Syst. Comput. Conf. PSCC 2018*, 2018.
- [17] E. T. Kj and E. T. Kj, “Terms of access to and use of the datahub – Grid company.”
- [18] THEMA Consulting Group, “Data Exchange in Electric Power Systems: European State of Play and Perspectives,” 2017.
- [19] “EPEX SPOT SE: About EPEX SPOT.” [Online]. Available: <http://www.epexspot.com/en/company-info>. [Accessed: 29-Jan-2019].
- [20] P. Pinson, L. Mitridati, C. Ordoudis, and J. Ostergaard, “Towards fully renewable energy systems: Experience and trends in Denmark,” *CSEE J. Power Energy Syst.*, vol. 3, no. 1, pp. 26–35, 2017.
- [21] “Towards Smarter Grids: ENTSO-E Position Paper on Developing TSO and DSO Roles for the Benefit of Consumers.” [Online]. Available: https://www.entsoe.eu/2015/03/04/towards_smarter_grids_entso-e_position_paper_on_developing_tso_and_dso_roles_for_the_benefit_of_consumers/. [Accessed: 16-Jan-2019].
- [22] S. Horsmanheimo, H. Kokkonieni-Tarkkanen, P. Kuusela, L. Tuomimäki, C. A. Andersen, J. Dall, F. P. Andrén, M. Stephan, F. Kupzog, J. L. Baut, S. Holmstrøm, (Sintef-Ict, J. H. Kazmi, M. Faschang, and F. Kupzog, “ICT Architecture Design Specification,” 2017.

Publication: J1

(Journal Paper)

**Integrated Approach for Network Observability and State Estimation in Active Distribution
Grid**

Basanta Raj Pokhrel, Birgitte Bak-Jensen, Jayakrishnan R. Pillai

This paper is published in *Energies* 2019, Volume 12, Issue 12 (ISSN 1996-1073; CODEN: ENERG).

DOI: <https://doi.org/10.3390/en12122230>

Article

Integrated Approach for Network Observability and State Estimation in Active Distribution Grid

Basanta Raj Pokhrel *, Birgitte Bak-Jensen  and Jayakrishnan R. Pillai

Department of Energy Technology, Aalborg University, 9220 Aalborg, Denmark; bbj@et.aau.dk (B.B.-J.); jrp@et.aau.dk (J.R.P.)

* Correspondence: bap@et.aau.dk

Received: 14 May 2019; Accepted: 10 June 2019; Published: 12 June 2019



Abstract: This paper presents a unique integrated approach to meter placement and state estimation to ensure the network observability of active distribution systems. It includes observability checking, minimum measurement utilization, network state estimation, and trade-off evaluation between the number of real measurements used and the accuracy of the estimated state. In network parameter estimation, observability assessment is a preliminary task. It is handled by data analysis and filtering followed by calculation of the triangular factors of the singular, symmetric gain matrix using an algebraic method. Usually, to cover the deficiency of essential real measurements in distribution systems, huge numbers of virtual measurements are used. These pseudo measurements are calculated values, which are based on the network parameters, real measurements, and forecasted load/generation. Due to the application of a huge number of pseudo-measurements, large margins of error exist in the calculation phase. Therefore, there is still a high possibility of having large errors in estimated states, even though the network is classified as being observable. Hence, an integrated approach supported by forecasting is introduced in this work to overcome this critical issue. Finally, estimation of the trade-off in accuracy with respect to the number of real measurements used has been evaluated in order to justify the method's practical application. The proposed method is applied to a Danish network, and the results are discussed.

Keywords: grid observability; active distribution system; meter allocation; parameter estimation

1. Introduction

Power flow in distribution networks has traditionally been one-way towards the consumers from the substation. Now the scenario is changing, and networks are becoming bidirectional. This is due to substantial demand response programs and interconnection of time-varying distributed generation (DG) at the distribution network (DN) level (medium voltage (MV) and low voltage (LV)) [1]. Such active power system networks can be controlled properly only when the actual system state is known. In addition, there is a threat to network operators from bidirectional power flow causing operational issues for network security and voltage balance [2], which forces network operators to carry out security assessment. For this objective, network states (voltage magnitudes (V) and angles (θ) at each bus), should be evaluated under all operating conditions [3]. Based on the predicted network states, the other network parameters can be calculated, and the operators can run control modules and handle further operation effectively. To ensure the availability of estimated states, power industries today use observability analysis. However, the accuracy of the estimated states cannot be guaranteed due to a lack of sufficient real measurements and error in load/generation forecasting, especially in distribution grids. Topology change and flaws in data communication are some of the culprits for measurement inadequacy. The consequence of this is network un-observability, but the observability of this unobserved network can be reinstated by using some defined measurements [4].

Any network can be classified as observable if it is possible to calculate all system states for the given measurements and topology. There are two predominant approaches for observability analysis: (a) topological: based on the graph theory analysis and decoupled measurement model and (b) numerical: based on the numerical factorization of gain matrices using either coupled or decoupled measurement models [5]. In addition to these two methods, some other alternative approaches have also been applied for network observability assessment in power distribution grids. For instance, by defining the probability index, local observability assessment using graph theory criteria etc. [6]. The method of distribution grid observability enhancement using a smart meter data is explained in [7]. This method uses both time-varying injections and stationary conventional load data from the smart meter as metered and non-metered data for observability improvement. State estimation in this case is executed using the metered data from a small number of buses to solve the non-linear power flow equations over consecutive time instants. Observability of the network depends on number, type and locations of the measurements used, but not on the method followed. Generally, there are sufficient measurements available in the transmission network that these methods work well there. However, due to economic reasons, there are fewer measuring devices (e.g., power, current and voltage measurements) in distribution systems, especially at the MV level, so they are generally operated with reduced observability. On the other hand, in the emerging scenario, the use of smart meters at the LV level (every customer connection point) is rapidly increasing because of the availability of modern advanced metering infrastructures (AMI) [1]. Some of the examples of increasing measurements at the distribution level are: (a) the European Union's (EU) initiative to replace 80% of traditional electricity meters with smart meters by 2020 [4], (b) installation of more than 70 million (nearly half of U.S. electricity customers) AMI in the United States (U.S.) [8], etc. Therefore, in future there will be a huge amount of data available from almost every node in the LV distribution grid, and they will be stored in data centers such as data hubs. These data can be used for any applications. For control applications, these large amounts of data gathered by smart meters have to be processed and used in an economical way. Hence, smart selection of minimum key data from the huge pool of available data from customer locations as well as from other specific locations will enhance the observability of active distribution networks (ADNs), while at the same time, ensuring higher accuracy of the estimated states of the observable network is the main challenge [7]. The Fisher information-based meter placement technique by minimizing errors in estimated state vector is proposed in [9]. It uses the D-optimality criterion, and a Boolean-convex model is used for optimization of the problem formulation. A meter placement algorithm to improve the estimated voltage and angle at each bus in the network is described in [10]. This technique is based on the consecutive upgrading of a bivariate probability index that is applied in medium voltage networks. The minimum meter placement technique discussed in this paper is a simple algebraic technique that can be applied in both MV and LV control applications. For MV grids, it will determine the best minimum metering locations, and for LV grids, it will identify the minimum key data from the huge pool of smart meter data. Using these smartly selected data, the respective networks can be fully observed with an accurately estimated network state from all nodes.

A reduced observability scenario below the substation is one of the reasons for the limited use of distribution state estimation (DSSE) by the utility. However, now, to address the challenges resulting from the increasing penetration of flexible resources and DGs at DN, real-time network models based on DSSE are becoming more essential for operation and control of the DN [11]. In the available literature, many vital issues in the development of DSSE have been discussed [12–14]. Proposed algorithms have been categorized based on simplification in order to speed up the estimation, selection of the state variables, and the procedures for integrating diverse measurements. Considering the choice of state variables, branch current-based and node voltage-based state estimators are the two main categories that would ultimately result in similar accuracy at the end [15]. The WLS (weighted least square) method's performance analysis with respect to the choice of state variables and comparisons on the basis of accuracy, performance and bad data detection capability were reported in [16]. To use the estimated network state information for operation and control, state estimation has to be dynamic, irrespective

of the method used for estimation. Dynamic state estimation is a recurrent estimation in a time sequence based on several measurement snapshots. For the estimation of large distribution networks, the execution time will be longer if we assume a single estimation process for the whole network. Therefore, distributed DSSE methods can be used to overcome such issues, executing the DSSE module in different sub-areas of the distribution network locally. Network division for this purpose can be carried out according to topological framework, geographical standpoint or measurement locations to solve the problem via local estimators in that particular sub-area. However, it is challenging to use DSSE in real life networks due to the limited number of real measurements, delay in communication, and un-synchronized measurements, which are detrimental to multi-area estimation accuracy [15]. The Distribution System State Estimation procedure with multi area architecture is discussed in [17]. It is based on a two-step procedure, i.e., local estimation followed by global estimation by using integrated measurement information from adjacent areas. The WLS estimation principle is used to identify the impact on the estimation accuracy of sharing the measurements among different areas. To monitor the dynamic behavior of the power system, for example, in order to know the quasi real-time operating condition in case of any fast-evolving contingencies, phasor measurement unit (PMU) measurements are included in the measurement set used by the state estimation [18]. PMU measurements comprise a voltage phasor at a bus and a current phasor through the line incident to that bus, and have sampling synchronized to a common reference through a GPS signal at widely spread locations [19]. A number of approaches can be found in the literature to include PMU data set into the existing conventional measurement setup [20]. If only voltage and current measurements from PMU are used, the state estimation problem will be linear, but it will be nonlinear with the presence of both PMU and conventional measurements. Therefore, to linearize the problem, the measured phasors in polar form can be converted to an equivalent rectangular form. Key challenges due to the inclusion of PMU measurements include: false data injection attack in the wide area measurement system [21], convergence problem of the hybrid state estimator during the iterative process due to uncertainty introduced by the instrument transformers, their connection with digital equipment and A/D converters [22], etc. On the other hand, to overcome the limitation of real measurements, when large number of virtual measurements (that may have significant uncertainties) are used to make the network observable, there is a high possibility of system states deviating from their actual values. Hence, the optimal number and specific type of real measurements collected from specific locations are essential to address the necessities of applications for real-time operation with high accuracy [23,24]. Therefore, the challenges to develop new real-time monitoring and management solutions for smart grid still exists, such as:

1. Accurately observing the whole distribution network using minimum real data and maximum pseudo measurements.
2. Developing an integrated approach for accurate, adaptive and efficient DSSE methodologies equipped with minimum measurement technique for wide area monitoring that can be implemented in the active distribution network.
3. Identifying the practical trade-off between network observability, number of installed measuring devices, and accuracy of estimated states.

These challenges related to measurement data utilization and its trade-off in DMS to enhance the state estimation are addressed in this paper. The main contributions of the paper are: development of a unified network observability assessment technique using minimum measured data, development of a technique to identify critical measuring locations for SE based on a bus prioritization approach, and formulation of a procedure to evaluate the trade-off between SE accuracy and the number of real measurement devices to be considered. This enables the user to maintain estimation precision in the distribution network with a lower burden. Overall, the paper is structured as follows: the problem statement is described in Section 2 and the overall methodology and algorithm is explained in Section 3, which covers observability assessment, meter placement analysis, network parameter estimation and

accuracy trade-off analysis between the number of used measurements and the accuracy of estimated states. Improved forecasting for pseudo measurements of loads/generations are stated in Section 4. Case studies with results and discussion are presented in Section 5. The conclusions of the paper and the directions of future work are finally summarized in Section 6.

2. Problem Statement

Network topology, grid parameters, field measurements and system data correlation are never fixed; everything depends on the operating conditions. Due to these uncertainties, network modelling is never perfect, and inaccuracies are contained in the DSSE results. When the database is extremely large, network reduction may help to improve the estimation accuracy to some extent. Key essential tasks for the enhancement of observability and improvement of accuracy of online models are: synergize the massive diverse data in different data formats from several information systems, synchronize the polling cycles, and minimize the communication delay and variation in measurements [25]. Generally, three types of measurements are considered in DSSE [15].

1. Equipment connectivity status received from Geographic Information System (GIS).
2. Real-time measurements from distribution SCADA systems (e.g., voltage, current and power flow) embedded with measuring units (e.g., smart meters, PMU, remote terminal unit (RTU), AMI, etc.).
3. Customer/prosumer's demand and DER output data (active and reactive power) from data management system.

If all of these numerous measurements are used, it may give better accuracy, but will require additional bandwidth for a communication infrastructure with suitable reliability. This will then lead to other problems, like data overload and extra financial burden. On the other hand, limited use of real-time measurement cannot ensure the overall observability of the network [26,27]. To minimize the use of real measurements, a large number of pseudo and virtual measurements can be used. Load and generation forecasts are pseudo measurements, whereas zero voltage drops in closed switching devices, zero bus injections at the switching station nodes, etc., are virtual measurements. However, changes in the behavior of power consumption because of external factors like new tariff structures, environmental condition, etc., and the allocation of greater weight to virtual measurements and lower weight to pseudo measurements may lead to ill-conditioned systems [15]. Therefore, this problem is tackled in this paper by utilizing maximum pseudo measurements only (injection measurements calculated from forecasted load/generation profiles) with a trade-off analysis where DSOs can achieve observability in their distribution grids with higher accuracy in estimated states by using minimal real measurements. The overall workflow for this problem is presented in Figure 1. As shown in Figure 1, for the particular network parameter to be estimated (in this work voltage in each bus), the type and combination of measurements (PV or PQ or IV or PQI, etc.) required are identified based on a preliminary assessment based on the available network topology and information. The best combination of measurements for real networks is identified in this preliminary assessment using the method explained in [28], and consists of analyzing the impact of number and placement of smart meter data on errors in state estimation using a standard network. This is a onetime exercise, and there is no need for repeated analysis of the preceding calculations. This is the first step, and this will identify the key measurement parameters and their locations, to a certain extent. It is followed by the observability assessment of the network with minimum meter placement, which is described in Section 3, below. Once the network is identified as being observable with minimum measurements, the state estimation (SE) is triggered. For the SE, real data from the identified key meters, together with the pseudo measurements for the rest of the nodes (which have no real measurements available), are supplied. Finally, a trade-off analysis between the number of real measurements used, the level of network observability and state estimation accuracy is carried out. For the estimation of network parameters, the weighted least square-based approach based on the Newton-Raphson method is

applied. A detailed explanation of the methodology followed for each working block represented in Figure 1 is explained in Sections 3 and 4 below.

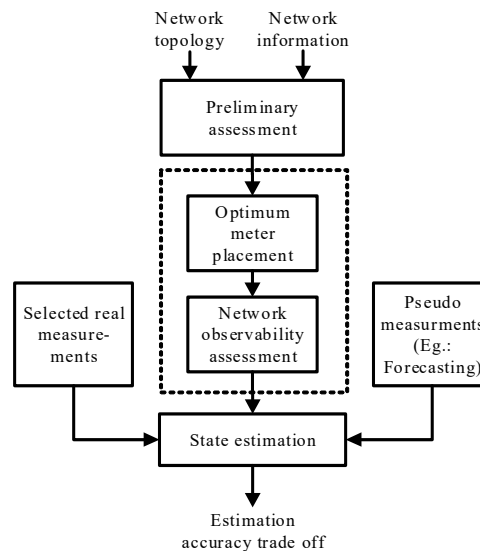

Figure 1. Working flow diagram of the proposed model.

3. Observability Assessment

The first stage in the assessment of observability is to choose estimation variables, and the best combination of parameters to be measured. This is termed preliminary assessment in this paper. It will minimize the iteration cycle in SE and give the minimum estimation error to a certain extent. For voltage estimation, line flow measurements are found to be more crucial [28]. It depends on network type and the variables to be estimated. As described in [28], if the parameters to be measured from specific locations are selected properly, better estimation quality can be achieved even with fewer real measurements. As explained above, once the estimation variables and the proper combination of measurements of parameters are selected, the actual network observability assessment will start, followed by state estimation. If the network is identified as being unobservable, all branches in it that cannot be observed have to be determined first. Then, by removing unobservable branches, the network can be divided into many individual observable islands that can be treated individually and merged later to have a single observable island. To improve the overall observability of the whole network, further analysis on the determination of specific measurement locations and the selection of minimum measurements has to be carried out [29]. The proposed integrated algorithm for observability assessment and its application in SE is given in Section 3.

Algorithm for Network Observability, SE and Accuracy Trade-Off

Algorithm for Observability Check (AOC):

- **Step 1:** Calculate measurement Jacobian matrix (H) and its gain matrix (G) [5,29].
- **Step 2:** Perform triangular factorization of G and evaluate its triangular factors (L: lower factor). Using triangular factors, identify diagonal matrix (D) [5].
- **Step 3:** Test for zero pivot in D, and if D is equal to one, network is observable [29]. If network is observable proceed to state estimation for this go to 'step one in Algorithm for SE formulation'; otherwise go to step four.
- **Step 4:** Determine test matrix W using equation: $L^T W^T = e_i$ and calculate another test matrix C using equation: $C = A W^T$ where A is incidence matrix of branches and buses.
- **Step 5:** Identify unobservable branches corresponding to the row in 'C' with at least one non-zero element. Remove all unobservable branches

- **Step 6:** Prepare the list for probable measurement points. Prioritize them. Highest priority for placing a meter is assigned to the bus that has the maximum number of incident lines in the unobservable region. Line flow measurement from the branches between the observable islands and the injection measurements from the buses at the boundary of these islands are the next most suitable candidate measurements, which can merge the islands. Current flow measurement at the beginning of the feeders are another prioritized measurement, and feeders with greater length and higher number of branches are of higher priority among the others. Select the measurement points based on priority, and go to step one for all new measurements added.

Normally in MV distribution systems, there is a limitation due to economic concerns on the availability of adequate real measurements from each node; therefore, a large number of pseudo measurements are used for the analysis. Therefore, even though the network is identified as being observable, there is a high chance that an estimated state can differ significantly from the actual state. Hence, re-examination of network observability considering the accuracy of the estimated states is recommended.

State Estimation Formulation:

SE is the core of the security analysis function in power systems. It acts like a filter between raw measurements and application functions like control and protection modules. Based on the available measurement sets, it estimates the network status. The state of the network is defined by voltage magnitude (V) and angle (θ) at every bus (i.e., $2n$ state variables) for an 'n'-bus power system network [5,30]. The basic algorithmic steps for network state estimation are given below:

SE Algorithm [5,30]:

- **Step 1:** Represent the network model by state vector as shown in Equation (1). If bus 1 is considered to be the reference, it is set as ($\theta_1 = 0$).

$$x^T = [\theta_2, \dots, \theta_n, V_1, \dots, V_n] \quad (1)$$

The measurement vector (z) is related to the state vector (x) by a nonlinear function (h) and a vector of measurement error (e) as given in (2). These functions and their behavior are dependent on network topology and actual power flow.

$$z = h(x) + e \quad (2)$$

- **Step 2:** Define the objective function as represented in Equation (3) and minimize it for the network estimation. To minimize this objective function, WLS—the most commonly used method—is used in this paper. Here, R , σ^2 and m represent the measurement error covariance matrix, measurement variance and the number of measurements, respectively.

$$\min J(x) = [z - h(x)]^T \cdot R^{-1} \cdot [z - h(x)] \quad (3)$$

$$R = \text{diag}[\sigma_1^2, \sigma_2^2, \dots, \sigma_m^2] \quad (4)$$

This approach determines the variance of the estimated state variables by:

$$\text{cov}(x) = [H(x)^T \cdot R^{-1} \cdot H(x)]^{-1} \quad (5)$$

$$H = \left[\frac{\delta h(x)}{\delta x} \right] \quad (6)$$

Where the diagonal elements of $\text{cov}(x)$ represent the variance of the estimated state variables.

- **Step 3:** Once the all the network states are estimated, accuracy is evaluated based on the number of measurements used. Go to ‘step one of algorithm for accuracy trade-off in state estimation’.

Algorithm for accuracy trade-off in state estimation (AAT):

- **Step 1:** Choose the desired confidence level (CL). This represents the risk that the true value goes beyond the boundary of the confidence interval (CI), i.e., the lower the CL, the higher the risk, and vice versa [31].
- **Step 2:** Calculate the probability density function (PDF) of the estimated states using Equation (7) [5].

$$F_i(a_i) = \frac{1}{\sqrt{2\pi\sigma_i^2}} e^{-\frac{(a_i-E_i)^2}{2\sigma_i^2}} \quad (7)$$

Where I is the total number of network parameters that has to be estimated, and for each network parameter ‘ i ’, its estimated value is E_i for $i = [1, 2, \dots, i, \dots, I]$. σ_i^2 represents the variance of ‘ i ’, whereas a_i denotes a possible value of this parameter ‘ i ’. There are many methods for calculating the PDF of an estimated parameter in order to calculate CI. Gain matrix-based approaches assuming Gaussian distribution have been used in this work, since the formulated observability assessment method is independent of the PDF calculation method [31,32].

- **Step 3:** Calculate confidence interval (CI) for each defined PDF. For predefined values of CL, the CI end points, a_i min and a_i max, of the estimated parameter i have to satisfy Equations (8) and (9) [31].

$$\int_{a_i \text{ min}}^{E_i} F_i(a_i) \cdot da_i = \frac{CL}{2} \quad (8)$$

$$\int_{E_i}^{a_i \text{ max}} F_i(a_i) \cdot da_i = \frac{CL}{2} \quad (9)$$

The CI can be calculated by multiplying the standard deviation by the coverage factor related to the predefined CL. a_i min and a_i max are the endpoints of the CI and represent the accuracy of the estimated value of parameter i . Then, calculate the maximum expected difference between E_i and its true value as given by Equation (10).

$$\text{Maximum expected difference between } E_i \text{ and its true value} = |a_i \text{ max} - a_i \text{ min}| \quad (10)$$

- **Step 4:** Access the estimation accuracy. If Equation (10) is satisfied, the estimation can be classified as accurate and stop the process. Otherwise, go to step five.
- **Step5:** Redefine the measurement placement with next possible measuring option, change the ratio of real and pseudo measurements, and go to ‘step six of algorithm for observability check’.

The overall methodology discussed in Section 3 in the form of different algorithms can be combined to form a compact flowchart as shown in Figure 2, systematically interlinking all the mathematical models (Equations (1)–(10)) for the complete analysis.

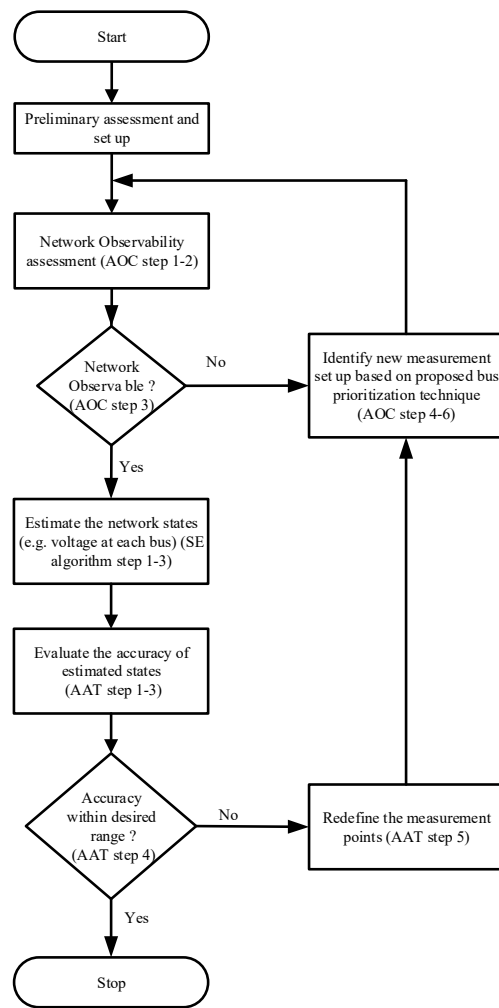

Figure 2. Compact algorithm for integrated assessment.

4. Improved Forecasting for Pseudo Measurement Modelling

Pseudo measurements are used in the network parameter estimation process to minimize the use of real measurements. For instance, even if real measurements are not sufficient to observe the network, its observability can be established by utilizing the calculated pseudo measurements. However, the accuracy of estimated states in this case depends on the accuracy of the pseudo measurement models. Pseudo-measurements here refer to forecasted load/generation values based on previous real measurements and other parameters like weather, type of load, etc. An upgraded short-term forecasting technique is proposed in this work for higher accuracy to determine the active demand and flexible generation capacity. This method considers weather forecast, historic load/generation statistics, and social and technical events. Due to the capability for handling both linear and non-linear relationships, and the facility for learning these relations directly from the data being modelled, the artificial neural network (ANN) technique is used in this work [33,34]. To obtain more accurate load forecasts, one may have to consider some other factors other than the load history that can influence the use of load by the consumers, such as time factors, weather data, possible customer classes, etc. A correlation (R) analysis is carried out to identify the most influential factor in the load forecasting using Equation (11). Here, p and q are variables to be correlated and \bar{p} , \bar{q} are their respective means. For details on forecasting models and analysis, please refer to [33].

$$\text{Correlation (R)} = \frac{\sum(p - \bar{p})(q - \bar{q})}{\sqrt{\sum(q - \bar{q})^2(p - \bar{p})^2}} \quad (11)$$

5. Case Study

The methodology described in Sections 3 and 4 is simulated for a real network and is discussed in the following sections. To demonstrate the applicability of the proposed methods, case studies have been performed on a model of a 52-bus MV distribution network from the Lind area in Denmark. For simplicity, the actual network is reduced to a 30-bus network preserving its radial nature and feeder connections, as given in Figure 3. While reducing the network, 24-load points are lumped up, i.e., five loads to bus3, three loads to bus 11, one load to bus 12, three loads to bus 13, two loads to bus 14, one load to bus 17, four loads to bus 18, and five loads to bus 19. Therefore, with this setup, in the test network, the maximum load of 1289 kW is at bus 19 and next largest load size (1246 kW) is at bus 18, while the minimum load of 18 kW is at bus 16. The typical R/X ratio of distribution lines in this network varies between 7.07 to 1.38.

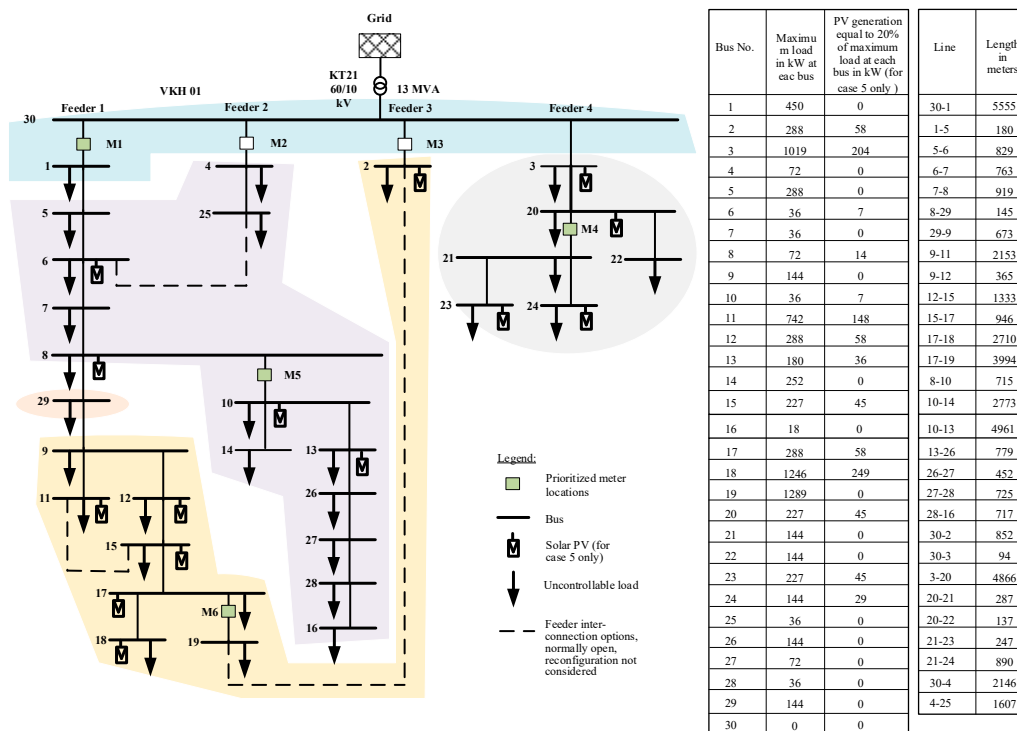

Figure 3. Modified MV network of Lind area, Denmark (observable islands in case 3).

The types of load and the state of the transformer tap changer will have an impact on network performance. For simplicity, an operating scenario in which all distribution transformers (buses 1 to 29) are loaded with a capacity factor of 40% and load power factor of 0.9 is assumed for the load flow and network measurements. The load distributions in all of the buses in this scenario are given in the table included in Figure 3. This operating condition is the peak load scenario for the main transformer (KT21). Another assumption is the presence of solar PV, which is considered to be available only in case 5.

Initially (case 1), it is assumed that 14 measurements from the substation (bus 30), the far end of the feeders (buses: 2, 11, 14, 16, 18, 19, 22, 23, 24, 25), and lines (6–7, and 17–19, i.e., close to the substation and at the far end of the longest feeder) are available. Thus, measurements are available for eleven power injections (net active/reactive power at the bus that can be obtained via load generation forecasting), two line flows (active/reactive power), and one voltage (at the substation). As per this measurement configuration, the network observability is analyzed by determining the gain matrix and its triangular factors. The upper triangular factor of the measurement gain matrix is evaluated and its diagonal elements (D) are identified. It is found that 28 elements out of 30 in D are zero. This shows the network is unobservable, and it is then divided into ten observable islands by removing the unobservable branches, as shown in Table 1. The candidate measurements list is prepared in

consideration of the boundary of observable islands. To justify the requirement of bus prioritization, initially, power injection measurements close to buses 3, 6, 12, 4, 27, and 29 are selected arbitrarily from the list as case 2. After each added measurement, observability assessment is carried out. The upper triangular matrix is updated and its new diagonal elements (D') are found, in which 27 zero pivots are observed. Since significant improvement has not been achieved, the network is divided into eight observable islands. Now, the candidate measurements are prioritized according to the description given in step 6 of the observability algorithm in Section 3. Only 10 measurement locations (5, 7, 8, 10, 15, 17, 20, 21, 25 and 30) out of 16 candidate sites are considered, and those remaining are filtered out. In reality, both power/current flow and power injection measurements can be measured from the same smart meter. Based on the user's requirements, the smart meters can be tuned to measure specific parameters. This option is available in most of the smart meters available today. Therefore, for the new injection measurements to be added for case 3, locations 7 and 15 from the priority list, which are close to the branch flow measurements, are selected. Also, line 30–1, and 20–21 for the branch flow measurement are considered to be added as per priority for case 3. After these measurements have been added, the new upper triangular matrix is evaluated, and updated diagonal elements (D'') are found. It is noticeable that observability is improved in this case due to significantly reduced number of zero pivots. However, the network is not fully observable. In this case, five observable islands are identified. Next, in case 4, the candidate list is updated based on the observable islands in this case, and prioritized as 5, 8, 10, 15, 20, 25, 29 and 30. Injection at locations 15 and 20 from the boundary of the islands that are observable are now selected, together with the branch flow in lines 30–1, 20–21, 8–10 and 17–19 (M1, M4, M5 and M6), as per priority. The diagonal elements of the upper triangular matrix (D''') from the updated triangular factors are calculated. In matrix D''' , only one zero pivot can now be observed. This shows that the network is now fully observable. These case studies for network observability are summarized in Table 1. Once the network observability has been assessed, network states are estimated for each case using selected real measurements and pseudo measurements (the forecasted load and generation value at each bus that will give net injection measurements at the respective buses). This is followed by accuracy trade-off evaluation. The case studies for state estimation and accuracy trade-off evaluation carried out after the network observability assessment are presented in the subsequent Sections 5.1 and 5.2.

Table 1. Observability assessment results.

Cases Studies	% of Real Measurements Applied	Observable Islands	Remarks
Case 1 (C1): Initial Case	0	{30}, {1}, {5 6 7 8 25 4 10 14 13 26}, {27 28}, {16}, {9 11 12 15 17 18 19}, {2}, {3}, {20 21 22 23 24}, {29}.	Network Unobservable
Case 2(C2): Adding selected measurements without priority	30	{30}, {1}, {5 6 7 8 25 4 10 14 13 26 27 28}, {16}, {9 11 12 15 17 18 19}, {2}, {3 20 21 22 23 24}, {29}.	No significant improvement
Case 3(C3): Adding selected measurements as per priority	22	{30 1}, {5 6 7 8 25 4 10 14 13 26 27 28 16}, {9 11 12 15 17 18 19 2}, {3 20 21 22 23 24}, {29}.	Significant improvement
Case 4(C4): Adding selected measurements as per priority	26	{1 2 3 4 5 6 7 8 9 10 11 12 13 14 15 16 17 18 19 20 21 22 23 24 25 26 27 28 29 30}	Fully observable network

5.1. Parameter Estimation and Accuracy Trade Off

Network observability setups with the minimum number of identified measurements can only be useful if this configuration can be used to estimate network states close to the actual values. Therefore, for instance, voltage magnitude is estimated for each case and compared with actual measured values, as shown in Figure 4 for selected buses close to the substation (buses 1 and 2), the far end (buses 19 and

24), and the middle (buses 13, 15, 20 and 25) of the feeders. In the measurement a minimum voltage of 0.88 pu is observed at bus 18 when all feeder interconnection options (6–25, 11–15 and 2–19) are open, i.e., at the end of the first radial (the longest radial feeder in the setup), which violates the grid code [35]. Buses 13 and 15 are also in the same feeder as bus 18, but are towards the substation, so they have slightly more voltage than in bus 18. Since buses 25, 2, 20, and 24 are in the 2nd, 3rd and 4th feeders (short feeders, i.e., lightly loaded compared to the first feeder), respectively, they have higher bus voltages (close to 0.99 pu). In real network operation, reconfiguration is used to maintain the grid code (e.g., minimum voltage of 0.95 at bus 16 while closing 2–19 and opening 9–12), but reconfiguration is not considered in this paper. In addition, a fixed load of 40% is considered in this work to see the performance of the proposed algorithm in special cases (case 1–7). This loading scenario may not exist all the time in real network operation. The results are obtained from a series of repeated simulations in MATLAB (observability analysis) and DigSILENT power factory (load flow, measurement setup, and state estimation) and snapshots of the results are shown here. The accuracy class of all smart meters is considered to be 0.5, as per IEC 62053-11 [36]. In this simulation, bus 30, which is close to the main substation, is considered to be the reference bus, the measured voltage of which is 0.99 pu. The first feeder is extremely long compared to the other three feeders, so lower voltages are observed in the buses (e.g., in buses 1, 13, 15 and 18) in this feeder. Meanwhile, the other three feeders are short compared to the first feeder, so the voltages in the buses (e.g., in buses 2, 20, 24, 25) in these feeders are almost the same as the reference voltage, i.e., 0.99.

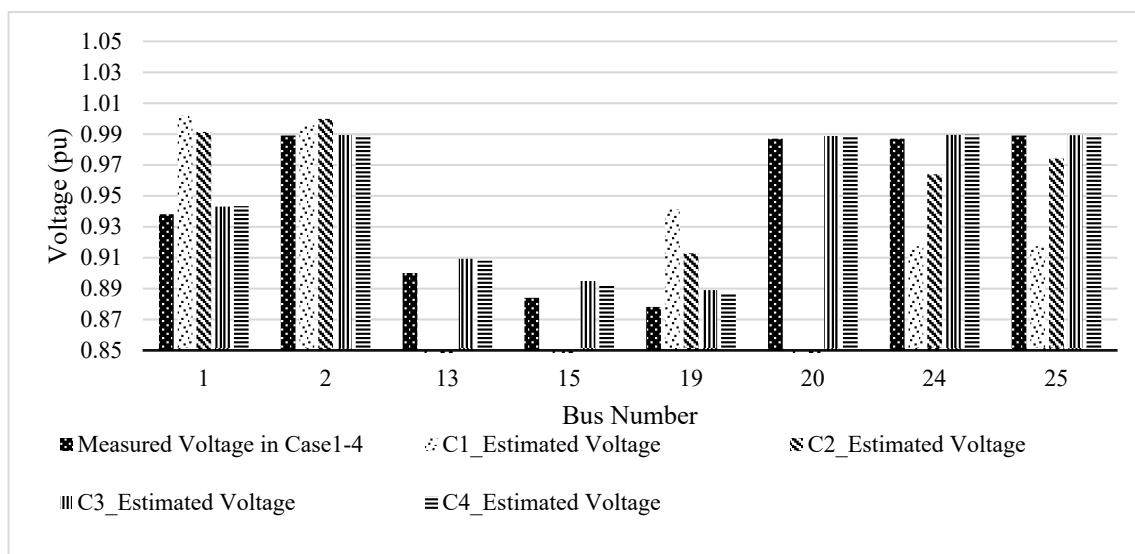

Figure 4. Comparison of estimated voltages for cases 1–4.

As expected, in case 1, where measurements are insufficient, the network is not fully observable, i.e., it is not possible to estimate the bus voltage for all buses (e.g., buses 13, 15 and 20), as is shown in Figure 4, where the magnitude of the estimated voltage for these buses is not available. In this case, overall network observability, which is a prerequisite for SE, is established by reducing the number of control variables (suspending the states to be estimated for buses 13, 15 and 20), and the bus voltages for rest of the buses is estimated. In case 2, real measurements (30%) are supplied, but without any bus prioritization, resulting in there being no significant improvement in the network state estimation. However, after applying the bus prioritization technique, i.e., by selecting only key measurements from the selected buses (only 22% real measurements) as in case 3, significant improvement is achieved. All network states including bus 13 and 15 are estimated due to the key added measurements from the prioritized buses. In case 4, which has 4% more real measurement than in case 3, all network states are estimated, with estimated states being closer to the real values. This verifies the network observability assessment results presented in Table 1. Comparison of parameter estimation errors in different case

studies for the selected bus voltages are shown in Figure 5. As seen here, it is a trade-off between higher accuracy and investment in measuring devices. The magnitude of error shows the deviation of estimated quantity from its respective measured value. Positive error means overestimation and negative error means underestimation. The magnitude of error depends upon the number, type and location of the measurements considered for the respective case studies. In case 3, a maximum error of 1.24% (in bus 19) using fewer real measurements can be achieved. Also, further improvement is observed with a maximum error of 0.96% in the estimated voltages in case 4.

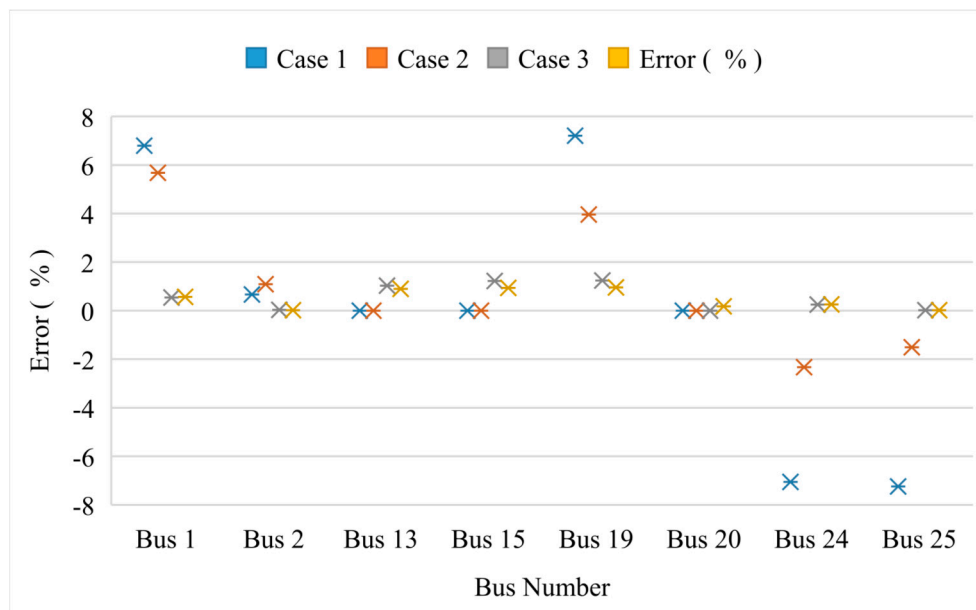

Figure 5. Comparison of errors in parameter estimation.

5.2. Worst Case Scenario Analysis

Under any operating conditions, all possible states have to be estimated to confirm the observability of a network. Therefore, the algorithm is tested in worst case scenarios, in which network states are likely to be violated. These scenarios are generally used during the planning phase of grid network operation, so it is known to DSOs [37,38]. Following worst case scenario (a), which is one of the worst operating scenarios, in which more DGs are integrated in the distribution network, other scenarios (b), (c) and (d) that could happen in real network operation have been set up to test the applicability of the method:

- Case 5 (C5): Minimum load and maximum generation. Minimum load (30% of maximum load at each bus) and maximum generation (20% of maximum load at each bus where generation is available) respectively.
- Case 6 (C6): Parameter estimation when line flow measurements (M4, M5 and M6) have an error of plus 5% of nominal reading.
- Case 7 (C7): Parameter estimation with large error on pseudo measurements models (over forecasting of load by 10%).

Network measurement setup is designated as a fully observable condition, i.e., as in case 4, which is then re-simulated to estimate the network parameters for the scenarios mentioned in cases 5–7; a snapshot of the results for voltage estimation is shown in Figures 6 and 7.

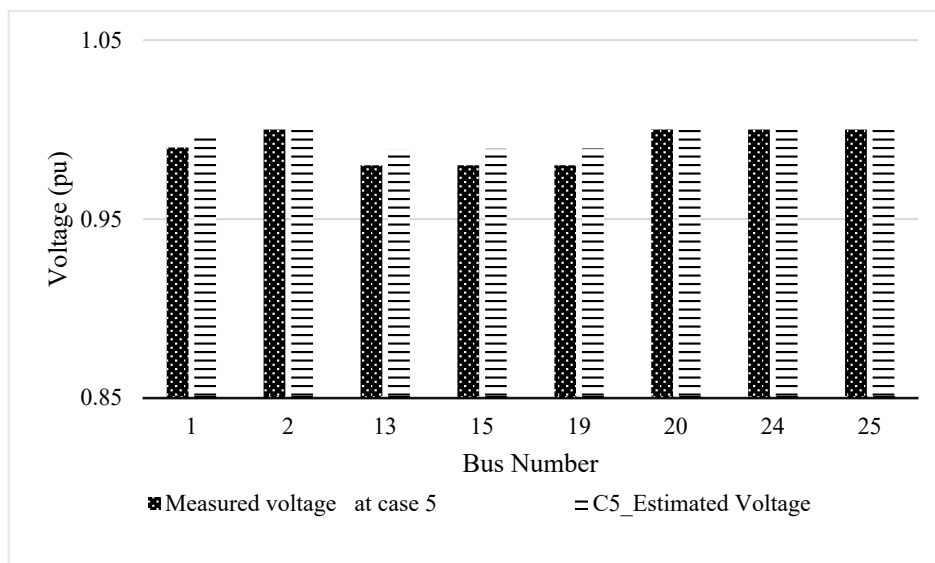

Figure 6. Comparison of estimated voltages for case 5.

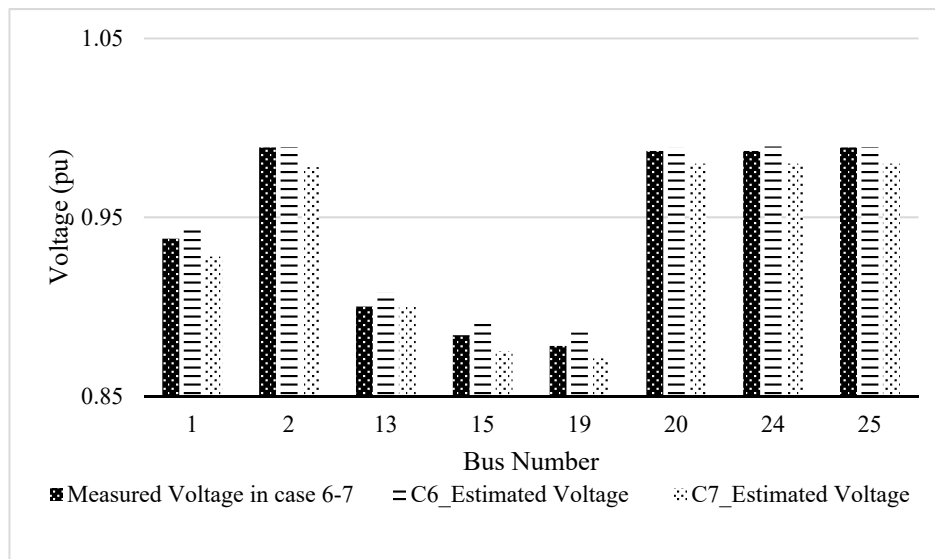

Figure 7. Comparison of estimated voltages for cases 6 and 7.

As seen in Figure 6, i.e., in case 5, it is found that using the same technique, network parameters can be estimated at close to their true value (maximum error 0.97%) even when the network is more active (i.e., in the presence of DG). About 0.01% more error than case 4 is noticed in case 5. This is because the estimator is modelled using net injection measurements at each bus, which logically include the impact of DG. However, a change in the system state due to RE penetration can result in the WLS estimator becoming trapped in local minima, and can add some error if the network is large, with the highest number of DGs [6]. From Figure 7, it can be seen that different patterns of impact are seen in case 6, i.e., only voltage estimates close to erroneous measurement points are more influenced (buses 13, 15, and 19). This is because the accuracy of the estimator is inversely proportional to the level of measurement error, and this will be reflected to the estimated states, which are close to the erroneous meter; furthermore, the effect could also be different with different types of measurements [39]. However, negligible impact is seen in the other buses, which are further away from the erroneous meters. The level of impact depends on the closeness of the meter and the number and locations of available meters in the same feeder [6,39]. This is valid for a radial feeder setup, which is

the predominant case in most power distribution networks. The impact of forecasting error (case 7) can be reflected in the estimation error to some extent. This is because most of the pseudo measurements (load and generation at each bus) will be noisy and result in erroneous injection measurements in all buses. Therefore, estimated voltage magnitude will be lower than the real value in some buses due to the application of overestimated forecasting. As shown in Figure 7, since the error for the forecasted load is plus 10% and the estimating variable is the voltage, not the load, at each bus, the maximum error recorded on voltage estimation in this situation (case 7) is only 1.1%. The magnitude of error on the estimated parameter depends on the number of pseudomeasurements used by the estimator that have been selected from an incorrectly forecasted load/generation.

Key results are summarized in Table 2, showing the advantage of the proposed methodology over the conventional method. This shows the possibility of achieving higher accuracy in estimated states with the minimum use of real measurements (26%). The maximum error in the estimated states without applying the proposed technique is improved to 0.91 % (without considering DG) and 0.92% (considering DG). Even by using only 22% real measurements, all network states can be estimated with a maximum error of 1.14%. This proposed technique is a simple algebraic technique that identifies the minimum number of meters to be installed for full network observability. Therefore, it will be more economical and reliable than more complex methods, such as the Fisher information-based meter placement technique described in [9], which uses the pre-specified number of additional measurement units from the set of candidate units. The highest-quality result (minimum SE error) is obtained with 23% real measurements (20 real measuring units, with each unit consisting of 3 real measurements, i.e., with 60 real measurements out of 260 measurements (both real and pseudo)) in the test network. Even though in the latter case, about 23% real measurements are used, technique followed is comparatively more complex than the proposed method.

Table 2. Comparison of key results.

Comparative Study	Bus with Maximum SE Error	Measured Voltage (per unit)	Estimated Voltage (per unit)	Maximum SE Error Recorded in the Network (%)
Initial setup with only basic available measurements, i.e., case 1	25	0.989	0.917	7.28
Without applying proposed method (with 30% real measurements) i.e., case 2	1	0.938	0.991	5.65
Applying proposed method (with 22% real measurements), i.e., case 3	19	0.878	0.888	1.14
Using proposed method (with 26% real measurements) without considering DG penetration, i.e., case 4	19	0.878	0.886	0.91
Using proposed method (with 26% real measurements) with DG penetration, i.e., case 5	19	0.98	0.989	0.92

6. Conclusions and Future Works

This paper proposed an enhanced numerical state estimation assessment for distribution networks using a minimal number of measurements. The proposed method determines critical data sets to be measured and modelled as real and pseudo measurements and identifies the network observability status using a bus prioritization technique followed by the calculation of network states and the identification of its accuracy. This is the key contribution of this paper. It is possible to filter out unnecessary measurements and minimize the iteration cycle based on the bus priority function and added pre-assessment. The advantage of this method is the analysis of the trade-off between the number of real measurements for gaining observability and the accuracy of the estimated states. Thus,

based on the required level of accuracy and application of network states, a minimal number of real measurements can be selected. Various case studies were performed, demonstrating the applicability of the proposed method in network state estimation.

The proposed methodology can be useful for identifying the minimum number of any type of measurement devices for network observability, for example, PMU, RTDS, smart meters, etc. For instance, inclusion of PMU will not have any impact on the observability analysis proposed in this paper, since the algorithm is based on the number and locations of the measurements, not on their dynamic behavior. However, the proposed bus prioritization technique can be useful for identifying the critical locations at which to place the PMUs in the network, not only improving the accuracy of state estimation, but also defending against data injection attacks with minimum cost [21]. This could be possible either by treating PMU measurements as additional measurements in the traditional data set (this will add the computational burden) or the using distributed computation of mixed/hybrid state estimation [40]. Future work will focus on the integration of the observability function and state estimation module with control blocks for application in real-time network control in real grids using various measurement setups available in modern power systems.

Author Contributions: B.R.P. is the main author of this article and prepared the draft. All co-authors have provided technical input, reviewed the draft and supplied technical supervision for the work. They also carried out the project administration and funding acquisition for the project.

Funding: This work is funded by Energinet.dk, the Danish transmission system operator, under PSOForskEL programme, grant no. 12414, for the project DECODE.

Acknowledgments: The authors thankfully admit the contributions of ABB, Eniig, Syd Energi and Kenergy from Denmark as well as Smart Lab, University of Saskatchewan, Canada for their feedback and input during different project meetings and discussions.

Conflicts of Interest: The authors declare no conflict of interest.

References

1. Tornbjerg, J. Smart Distribution Grids Power Europe's Transition to Green Energy DSOs—the Backbone of the Energy Transition. Danish Energy Association. 2017. Available online: https://www.danskenergi.dk/sites/danskenergi.dk/files/media/dokumenter/2017-11/DSO_Magazine_210x297_ENG_V10.pdf (accessed on 27 May 2019).
2. Baran, M.E. Challenges in state estimation on distribution systems. In Proceedings of the IEEE Power Engineering Society Summer Meeting, Vancouver, BC, Canada, 15–19 July 2001.
3. Gelagaev, R.; Vermeyen, P.; Vandewalle, J.; Driesen, J. Numerical observability analysis of distribution systems. In Proceedings of the 14th International Conference on Harmonics and Quality of Power (ICHQP), Bergamo, Italy, 26–29 September 2010; pp. 1–6.
4. Andreassen, J. SCADA/DMS/AMI/NIS: Obsolete? 2017. Available online: <http://blogs.esmartsystems.com/scada-dms-ami-nis-obsolete> (accessed on 18 October 2017).
5. Abur, A.; Expósito, A.G. *Power System State Estimation: Theory and Implementation*; Marcel Dekker: New York, NY, USA, 2004.
6. Dehghanpour, K.; Wang, Z.; Wang, J.; Yuan, Y.; Bu, F. A survey on state estimation techniques and challenges in smart distribution systems. *IEEE Trans. Smart Grid* **2019**, *10*, 2312–2322. [CrossRef]
7. Bhela, S.; Kekatos, V.; Veeramachaneni, S. Enhancing observability in distribution grids using smart meter data. *IEEE Trans. Smart Grid* **2018**, *9*, 5953–5961. [CrossRef]
8. U.S. Energy Information Administration (EIA). Available online: <https://www.eia.gov/tools/faqs/faq.php?id=108&t=3> (accessed on 8 October 2018).
9. Xygkis, T.C.; Korres, G.N.; Manousakis, N.M. Fisher information-based meter placement in distribution grids via the D-optimal experimental design. *IEEE Trans. Smart Grid* **2018**, *9*, 1452–1461. [CrossRef]
10. Singh, R.; Pal, B.C.; Vinter, R.B. Measurement Placement in Distribution System State Estimation. *IEEE Trans. Power Syst.* **2009**, *24*, 668–675. [CrossRef]
11. Heydt, G.T. The Next Generation of Power Distribution Systems. *IEEE Trans. Smart Grid* **2010**, *1*, 225–235. [CrossRef]

12. della Giustina, D.; Pau, M.; Pegoraro, P.; Ponci, F.; Sulis, S. Electrical distribution system state estimation: Measurement issues and challenges. *IEEE Instrum. Meas. Mag.* **2014**, *17*, 36–42. [[CrossRef](#)]
13. Huang, Y.-F.; Werner, S.; Huang, J.; Kashyap, N.; Gupta, V. State Estimation in Electric Power Grids: Meeting New Challenges Presented by the Requirements of the Future Grid. *IEEE Signal Process. Mag.* **2012**, *29*, 33–43. [[CrossRef](#)]
14. Liao, H.; Milanovic, J.V. Pathway to cost-efficient state estimation of future distribution networks. In Proceedings of the 2016 IEEE Power and Energy Society General Meeting (PESGM), Boston, MA, USA, 17–21 July 2016; pp. 1–5.
15. Primadianto, A.; Lu, C.N. A Review on Distribution System State Estimation. *IEEE Trans. Power Syst.* **2017**, *32*, 3875–3883. [[CrossRef](#)]
16. Pau, M.; Pegoraro, P.A.; Sulis, S. Efficient branch-current-based distribution system state estimation including synchronized measurements. *IEEE Trans. Instrum. Meas.* **2013**, *62*, 2419–2429. [[CrossRef](#)]
17. Pau, M.; Ponci, F.; Monti, A.; Sulis, S.; Muscas, C.; Pegoraro, P.A. An Efficient and Accurate Solution for Distribution System State Estimation with Multiarea Architecture. *IEEE Trans. Instrum. Meas.* **2017**, *66*, 910–919. [[CrossRef](#)]
18. Chakrabarti, S.; Kyriakides, E. PMU measurement uncertainty considerations in WLS state estimation. *IEEE Trans. Power Syst.* **2009**, *24*, 1062–1071. [[CrossRef](#)]
19. Asprou, M.; Kyriakides, E. The effect of PMU measurement delays on a linear state estimator: Centralized Vs decentralized. In Proceedings of the 2017 IEEE Power & Energy Society General Meeting, Chicago, IL, USA, 16–20 July 2017; pp. 1–5.
20. Thirugnanasambandam, V.; Jain, T. Placement of Synchronized Measurements for Power System Observability during Cascaded Outages. *Int. J. Emerg. Electr. Power Syst.* **2017**, *18*, 12–19. [[CrossRef](#)]
21. Yang, Q.; Jiang, L.; Hao, W.; Zhou, B.; Yang, P.; Lv, Z. PMU Placement in Electric Transmission Networks for Reliable State Estimation Against False Data Injection Attacks. *IEEE Internet Things J.* **2017**, *4*, 1978–1986. [[CrossRef](#)]
22. Chakrabarti, S.; Kyriakides, E.; Ledwich, G.; Ghosh, A. Inclusion of PMU current phasor measurements in a power system state estimator. *IET Gener. Transm. Distrib.* **2010**, *4*, 1104. [[CrossRef](#)]
23. Pegoraro, P.A.; Sulis, S. Robustness-Oriented Meter Placement for Distribution System State Estimation in Presence of Network Parameter Uncertainty. *IEEE Trans. Instrum. Meas.* **2013**, *62*, 954–962. [[CrossRef](#)]
24. Liu, J.; Ponci, F.; Monti, A.; Muscas, C.; Pegoraro, P.A.; Sulis, S. Optimal Meter Placement for Robust Measurement Systems in Active Distribution Grids. *IEEE Trans. Instrum. Meas.* **2014**, *63*, 1096–1105. [[CrossRef](#)]
25. Pegoraro, P.A.; Meloni, A.; Atzori, L.; Castello, P.; Sulis, S. PMU-Based Distribution System State Estimation with Adaptive Accuracy Exploiting Local Decision Metrics and IoT Paradigm. *IEEE Trans. Instrum. Meas.* **2017**, *66*, 704–714. [[CrossRef](#)]
26. Muscas, C.; Pau, M.; Pegoraro, P.A.; Sulis, S. Effects of Measurements and Pseudomeasurements Correlation in Distribution System State Estimation. *IEEE Trans. Instrum. Meas.* **2014**, *63*, 2813–2823. [[CrossRef](#)]
27. Celli, G.; Pegoraro, P.A.; Pilo, F.; Pisano, G.; Sulis, S. DMS Cyber-Physical Simulation for Assessing the Impact of State Estimation and Communication Media in Smart Grid Operation. *IEEE Trans. Power Syst.* **2014**, *29*, 2436–2446. [[CrossRef](#)]
28. Pokhrel, B.R.; Karthikeyan, N.; Bak-Jensen, B.; Pillai, J.R. Effect of Smart Meter Measurements Data On Distribution State Estimation. In Proceedings of the 19th IEEE International Conference on Industrial Technology (ICIT), Lyon, France, 20–22 February 2018; pp. 1207–1212.
29. Pokhrel, B.R.; Karthikeyan, N.; Bak-Jensen, B.; Pillai, J.R.; Mazhari, S.M.; Chung, C.Y. An Intelligent Approach to Observability of Distribution Networks. In Proceedings of the IEEE PES General Meeting, Portland, OR, USA, 5–10 August 2018.
30. Stevenson, W.D. *Elements of Power System Analysis*; McGraw-Hill: New York, NY, USA, 1982.
31. Brinkmann, B.; Member, S.; Negnevitsky, M.; Member, S. A Probabilistic Approach to Observability of Distribution Networks. *IEEE Trans. Power Syst.* **2017**, *32*, 1169–1178. [[CrossRef](#)]
32. Methods and Formulas for Probability Density Function. Available online: <https://support.minitab.com/en-us/minitab-express/1/help-and-how-to/basic-statistics/probability-distributions/how-to/probability-density-function-pdf/methods-and-formulas/methods-and-formulas/> (accessed on 16 November 2018).

33. Karthikeyan, N.; Pokhrel, B.R.; Pillai, J.R.; Bak-jensen, B.; Jensen, A.; Helth, T.; Andreasen, J.; Frederiksen, K.H.B. Coordinated Control with Improved Observability for Network Congestion Management in Medium-Voltage Distribution Grid. In Proceedings of the CIGRE Session, Paris, France, 26–31 August 2018.
34. Quan, H.; Srinivasan, D.; Khosravi, A. Short-Term Load and Wind Power Forecasting Using Neural Network-Based Prediction Intervals. *IEEE Trans. Neural Networks Learn. Syst.* **2014**, *25*, 303–315. [[CrossRef](#)] [[PubMed](#)]
35. Regulations for Grid Connection|Energinet. Available online: <https://en.energinet.dk/Electricity/Rules-and-Regulations/Regulations-for-grid-connection> (accessed on 16 November 2018).
36. IEC 62053-11. Available online: <https://webstore.iec.ch/publication/26235> (accessed on 6 November 2018).
37. Kulmala, A.; Repo, S.; Jarventausta, P. Using statistical distribution network planning for voltage control method selection. In Proceedings of the IET Conference on Renewable Power Generation (RPG 2011), Edinburgh, UK, 6–8 September 2011; pp. 41–41.
38. Celli, G.; Pilo, F.; Soma, G.G.; Cicoria, R.; Mauri, G.; Fasciolo, E.; Fogliata, G. A comparison of distribution network planning solutions: Traditional reinforcement versus integration of distributed energy storage. In Proceedings of the 2013 IEEE Grenoble Conference, Grenoble, France, 16–20 June 2013; pp. 1–6.
39. Sabri, N.C.O.; Majdoub, M.; Cheddadi, B.; Belfqih, A.; Boukherouaa, J.; El Mariami, F. Correlation between Weight, Error and Type of Measurements in WLS State Estimation of a Real Network. Available online: https://www.researchgate.net/publication/318582394_Correlation_between_weight_error_and_type_of_measurements_in_WLS_state_estimation_of_a_real_network (accessed on 28 May 2019).
40. Sangrody, H.A.; Ameli, M.T.; Meshkatoddini, M.R. The effect of phasor measurement units on the accuracy of the network estimated variables. In Proceedings of the 2009 Second International Conference on Developments in eSystems Engineering, Abu Dhabi, UAE, 14–16 December 2009; pp. 66–71.



© 2019 by the authors. Licensee MDPI, Basel, Switzerland. This article is an open access article distributed under the terms and conditions of the Creative Commons Attribution (CC BY) license (<http://creativecommons.org/licenses/by/4.0/>).

Publication: B1

(Book Chapter)

Architecture of integrated energy systems

Basanta Raj Pokhrel, N. Karthikeyan, R. Sinha, Birgitte Bak-Jensen, Jayakrishnan R. Pillai

This book chapter is submitted in the book series in Reliable and Sustainable Electric Power and Energy Systems Management, Springer 2019 – under review

Architecture of integrated energy systems

Basanta Raj Pokhrel*, N. Karthikeyan, Rakesh Sinha, Birgitte Bak-Jensen, Jayakrishnan R. Pillai
Department of Energy Technology, Aalborg University, Denmark

*Corresponding author: bap@et.aau.dk

1.1 Introduction

The energy system with all its energy carriers like electricity, water, district heating/cooling, gas, electric transport etc. are today mainly planned and operated independently. However, integrated design and intelligent operation will enable a much more efficient utilisation of energy and the infrastructure in the energy system [1]. An enhanced efficiency will save substantial investments in transmission network capacity and conventional back up production capacity especially when fossil fuels are replaced by renewable energy in the energy production. The energy system will become intelligent if it implies introduction of dynamic and active participation in all aspects of the system such as real time management and operation, smart metering and handling of intelligent technology like phasor measurement unit (PMU), State estimators etc. To be able to make the existing energy system intelligent, an architectural framework for its control and management has to be set up. The integrated energy system architecture proposed here is set up for the coordinated operation and planning of energy systems across multiple pathways to deliver reliable, cost-effective energy services in different forms. This will have a huge impact on the energy environment ensuring better energy efficient and more optimal use of the energy systems. The objective of this architectural framework is to set up methodological guidelines, which will help all energy system operators to have a coordinated operation among all networks to deliver required energy in an optimized way with minimum investment on infrastructure. Therefore, the purpose of this chapter is first to review the current energy system scenario that includes the electricity network (EN), gas network (GN), heating network (HN), cooling network (CN) and transport system (both electric and gas vehicles). Next, it proposes the future roadmap and identifies the possibilities of integrated operation, challenges and requirements to support the integrated energy system and finally it defines the belonging system architecture. This chapter describes the general system architecture for enhanced observability and controllability of integrated energy system (IES) for the above-mentioned scenario.

1.2 Energy system scenario and the roadmap

Innovation and technology associated with efficient energy conversion based on various sources of energy is one of the major global concerns with intended reduction of CO₂ emissions as well. Fig. 1 shows that almost 43% of the world CO₂ emission in 2012 comes from burning of coal followed by oil accounting for 33% [2]. Fig. 2 shows the share of global primary energy consumption

and its projection until 2040 [3]. Oil remains the world’s dominant fuel, making up roughly a third of all energy consumed. Coal is the second most energy source covering around 28% of global primary energy consumption. It shows that, in the long term, the percentage share of coal in energy market decreases to around 20% (with demand essentially flat) through 2040. Share of renewables is rapidly growing with 2.3% per annum between 2015 and 2040 [3].

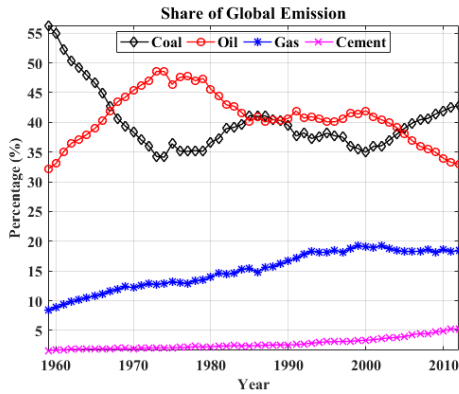

Fig. 1 Share of global emissions [2]

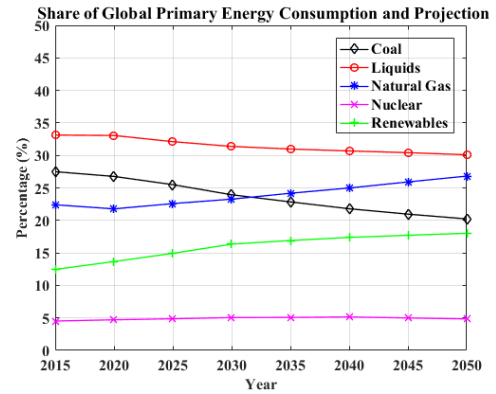

Fig. 2 Shares of global primary energy consumption and projection [3]

Energy demand can be associate with the economic and social development. A rapid economic boom needs to consider links to environmental sustainability. For more than two decades, the European Union (EU) has been leading global renewable energy deployment. The EU is looking forward for 100% renewable based energy system by 2050 and 20% by 2020 [4]. Thus, looking towards the EU progress and concept towards use of renewables gives broader insight of future prospective of IES. Under the framework of sustainable development with long-term targets, the European Commission has developed and adopted a number of supportive regulatory measures towards low-carbon technologies in the energy sectors. This has resulted in strong growth in renewable energy share from a 9% in 2005 to 16.7% in 2015 in this region [5].

Looking towards the energy consumption statistics of EU, the transportation sector uses 33% of total energy consumption as seen from Fig. 3 [6]. Household use 25% of the total energy consumption (Fig. 3), out of which 64.7% is used for heating and only 13.8% is electricity. Electricity is basically used for lighting and most electrical appliances except powering the main heating, cooling or cooking systems [7]. Thus, an approach to interlink other energy sectors such as heating/cooling and transportation with clean electricity or carbon neutral sources needs to be commissioned.

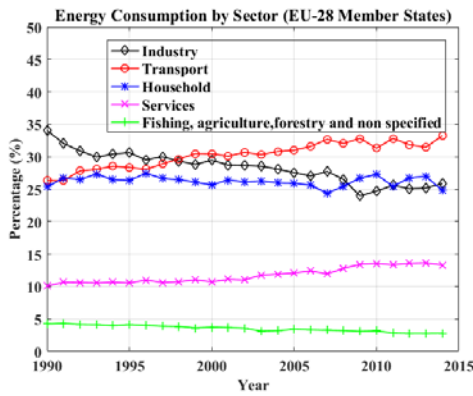

Fig. 3 Share of Energy Consumption by Sector in EU-28 Countries [6]

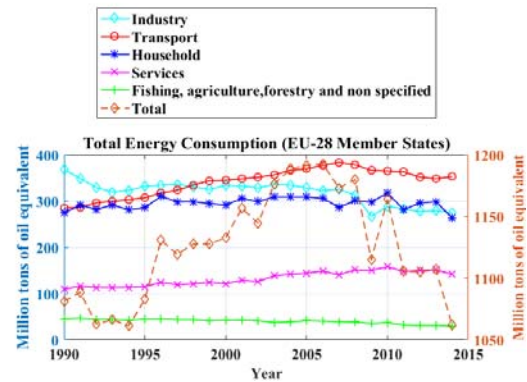

Fig. 4 Total Energy Consumption of EU-28 Countries (Right Y-axis for total consumption only)

The problem associated with global warming cannot only be met by a change in electricity generation with innovation in new technologies, policies, reliability, and economic models, but should also include flexible and efficient use of energy consumption with demand side management, its scheduling and new market structures. Fig. 4 shows, that the total energy consumption in the EU-28 member states has decreased by 11% between 2005 and 2015. The major decrement in energy consumption is in the industry (16.5%) and household sector (14.8%) [6]. This decrement in energy consumption is the result of improvements in end-use efficiency and lower heat consumption (favourable climate and energy efficient buildings).

The concept of energy mix has evolved from centralised fossil fuel based generation to decentralised and integration of renewable energy. Fig. 5 shows the future perspective of smart energy systems in Denmark as an example. Denmark has an ambitious milestones to meet 50% electricity demand by 2020, phase out of coal power by 2030, 100% heating and electricity demand based on renewable by 2050, and 100% Danish energy consumption including transport by 2050. Thus, Denmark is an example where such IES will be implemented due to increasing and higher amounts of decentralized generation. The smart energy system is sustainable, efficient, cost effective, integrated and intelligent [8]. The system is formed by integration of different energy transmission and distribution sectors such as the electricity grid, gas, district heating and cooling in a single system and linked to the transportation system as well. Each energy network has solutions for use of the renewable sources making the smart energy system cost effective through unique conversion sectors such as CHP (combined heat and power), waste-to-energy, heat pumps, electric boilers, fuel-cells, biogas, thermal gasification, electrolysis, and hydrogenation.

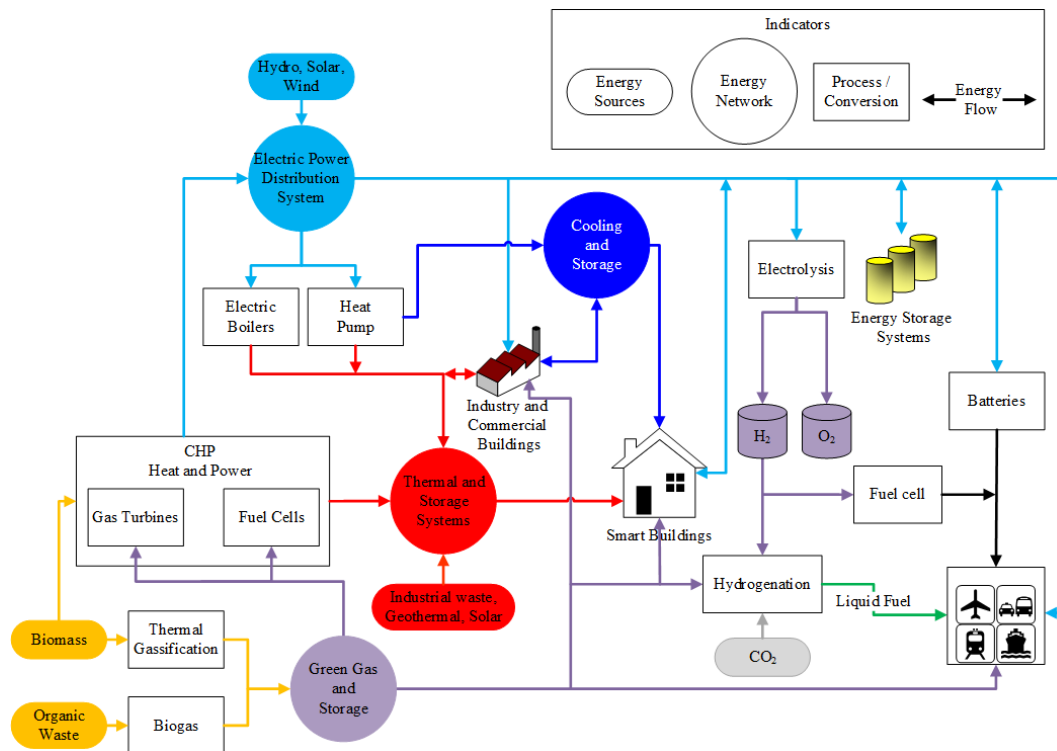

Fig. 5 Smart Energy System

The integrated energy system with energy production, distribution, storage, and consumption are linked together with operational flexibility in an intelligent way [9]. This is the key to an energy efficient system. Energy storage and conversion are crucial for a reliable and energy efficient system having high share of fluctuating renewable sources such as wind and solar. Transition towards modern sustainable energy is more dominated by the electricity sector. There are several methods investigated and available worldwide for storage of surplus electricity in the form of gas, heating and cooling water, batteries or synthetic fuel.

Power to Gas (P2G): Gas grid plays a crucial part in the smart energy system as it has capacity to balance the electrical grid by delivering necessary energy in the periods with low wind and solar. It plays a significant role by supporting the grid stability in grids with high share of renewable sources as well as decarbonisation of high energy density fuel transportation [10]. Gas produced through various technologies such as biogas, and thermal gasification of biomass, can be converted into synthetic natural gas using methanization processes and can then be injected into the national gas grids for distribution over long distance or stored [9]. Germany is the leading P2G nation followed by Denmark, Switzerland and United States [10].

Power to Heat (P2H) and Power to Cooling (P2C): Heating and cooling are closely interlinked and has good synergy with the efficient use of heat pumps to generate both heating and cooling at the same time. Cooling demand is far higher than for heating on a global scale. Benefits of heating and cooling networks are to provide cost effective solutions by taking advantage of the free market forces

driving price changes on different types of fuel [11]. Heating and cooling networks have storage systems to decouple demand and generation. Thus, excess energy harnessed from wind and solar can be converted into thermal and cooling energy for storage and user use. A review on market, technical, supply, environmental, institutional, and future contexts of district heating and cooling is presented in [12], [13].

Power to Transport (P2T): The Energy Information Administration has released data showing that the transportation of people and goods accounts for about 25 percent of all energy consumption in the world with private vehicles being the most frequently used. Alternatives for fossil fuel in the transportation sector are electricity (for railways and light vehicles), and biofuels and green gas for heavy transport [8]. The concept of vehicle to grid (V2G) allows further the transportation sector to participate actively in grid ancillary services such as voltage and frequency [14].

Integrated Energy Storage Solutions (IESS): IESS refers to the process of reserving energy in various media for future use. Energy harnessed through various processes due to, abundance availability of energy sources, or market price variations can take advantage by storing them in various forms for future use. In smart energy systems, IESS plays a significant role to harmonise synergy between electrical grid networks and other energy networks such as gas, heating and cooling. The electrical grid being the most vulnerable in terms of stability compared to other energy networks, IESS in smart energy system provides solutions for its stability. Battery energy storage provides fast response to support electric grid inertial response during transients [15] and provides a short-term storage solution. Mid-term storage solutions such as pumped hydro and batteries are useful for primary frequency response of the electrical grid. P2H and P2C can also provide mid-term storage solutions. Distributed heating and storage systems using electric boilers and heat pumps can serve as a flexible consumer load for the electric grid network [16], [17]. P2G provides a long-term solution for large storage to accommodate seasonal abundance of energy sources. It can participate in balancing the electric grid as secondary or tertiary response. Thus, IESS have potential solutions towards stable operation of smart energy systems through appropriate control system.

Besides energy generation, conversion, storage, and transmission, the intelligent energy consumption is also one of the major features of the smart energy system to enhance flexibility. It incorporates green and smart buildings, active participation of end user, and the transportation sector. Considering the Danish scenario as an example, almost 40% of total energy are consumed in buildings [18]. Space heating consumes around 85% of energy used in Danish's private households [19]. Thus, it is necessary to construct buildings with energy efficient designs and standards. Small-scale energy production such as solar PV and wind turbines, are allowed to participate with delivery of surplus energy to the electric grid. Apart from small-scale generation, there is an opportunity for the active

consumer to manage their energy consumption using smart home devices to supports balance between supply and demand. Smart home devices includes washing machine, dishwasher, refrigerator, heating systems, and electric vehicles, which can serve as flexible consumer loads. People are also motivated to save energy. Danes makeup remarkable share in energy saving by using bicycles that makes more than 20% of all trips [20].

Flexibility in production, conversion, storage and end-use technologies are possible with the support of information and communication technologies (ICTs). ICTs utilizes renewable energy sources as efficiently as possible to make important planning and operational decision. Smart meter data and the IT infrastructure will be immensely useful for an efficient coordination of the capability of dynamic energy demand and helping lower the energy consumption at peak times [8]. This is possible through application of smart energy systems. It not only helps in eliminating the energy losses due to human factors, but also enhances the human decision-making process by providing adequate information about energy consumption frequently. Flexibility in energy usage of customers from their normal consumption pattern in response to change in energy price or system reliability can be achieved with demand response management.

As discussed in the above paragraph, until now only up to two different energy networks are integrated for example P2G: Electricity and gas network integration, P2H and P2C: Electricity and thermal network integration etc. Due to the advancement on real-time monitoring, control and presence of multi energy carriers [21] now integrated operation of all the energy network can be possible provided suitable observability and controllability is applied to the appropriate energy network. The enhanced grid observability required for the integrated energy network is discussed in section 1.3 followed by the discussion on suitable control architecture based on different types of control in section 1.4.

1.3 Enhanced observability for integrated energy systems

Future integrated energy scenarios as discussed in section 1.2 can be implemented and operated in a coordinated manner by the energy utilities and can be optimized if energy network observability and controllability is redefined to incorporate the assets from different energy mix. In the integrated operation and control, that ensures a balance among cost, safety, reliability, overall sustainability and the environmental impact, network observability is a prerequisite to prevent violating energy network limits and conditions. Network observability analysis, Load (Electrical, heating, gas etc.) forecasting, Generation (wind, solar etc.) forecasting, and State estimation are the major components of network observability. In this chapter, ‘state estimation’ refers to the estimated value of energy network parameters close to real time based on minimum real time measurement and some pseudo measurements required for real time operation and control of the energy network. It is explained more

precisely later in section 1.3.3. An enhanced observability architecture for active electricity distribution grids is proposed in [22] and an architectural framework for network observability seen from energy system point of view is discussed later in detail.

The common integration platform proposed here is a generic and scalable module (energy hub) that can sense the energy flow and offers the flexibility in operation [23]. A detailed structure of the energy hub is explained in the proceeding section. Energy consumption (water, electricity, gas, heat) measured by smart meters at each energy hub are collected by a data hub. It will also gather other relevant data like meteorological information, individual network information, transport (electric and gas) schedule and traffic status etc. This information is used for monitoring and control of the energy system as a whole. A generic schematics for energy system observability is presented in Fig. 6. The aim of this structure is to support the controller for the basic control objective of each network to ensure optimum energy flow by guaranteeing the availability of minimum energy supply all the time. Due to this framework, for example the transport system operators can use the required energy from electricity or gas network based on their price. It also facilitates to formulate control and optimized operational schemes for all plants connected to the energy hub. The controller will send control signals to each device within the energy hub via the energy management system (EMS) module at each network so that they can maintain their required delivery in time. More or less prices of almost all other energy (water, heat, gas etc.) except electricity are fixed for a certain period (static). However, the electricity price is varying even within an hour (dynamic) [24]. Therefore, the real time electricity price can be sent to each customer premises via EMS so a more optimized operation can be achieved. For example, customers will turn on the washing machine and charge EV when price is cheap and electricity demand is low. This may cause grid congestions, which has to be properly addressed by the demand response management.

At present each energy network have their own management system with limited observability and controllability without any interlink and interoperability with other management system. These modules should be upgraded with proposed architecture as described in the below sections which are presented as EMS here. Each network operator is in charge of his respective EMS. Coordinated operation of all EMS set up is referred as IEMS in this chapter. The activation of control, scheduler, data processing, energy management for different schemes to intelligently combine different units of several energy sectors are processed individually in their respective system because EMS and observability modules frameworks are different for different systems. Only minimum information will be exchanged among all EMS and from each EMS to respective energy hubs.

1.3.1 Energy system observer

The energy system observer is a module proposed for each network separately. It will analyse and identify what, where and when to measure in the respective networks and systems to know the overall operational scenario. For each network, it will identify the measurement parameter, location and number of meters for the overall network observability. It also ensures the use of minimum data and number of meters / sensors to be considered. Based on the system observer feedback a minimum of real measurements will be collected and pseudo measurement modelling like forecasting will be carried out for the rest of parameters needed to ensure observability of the networks.

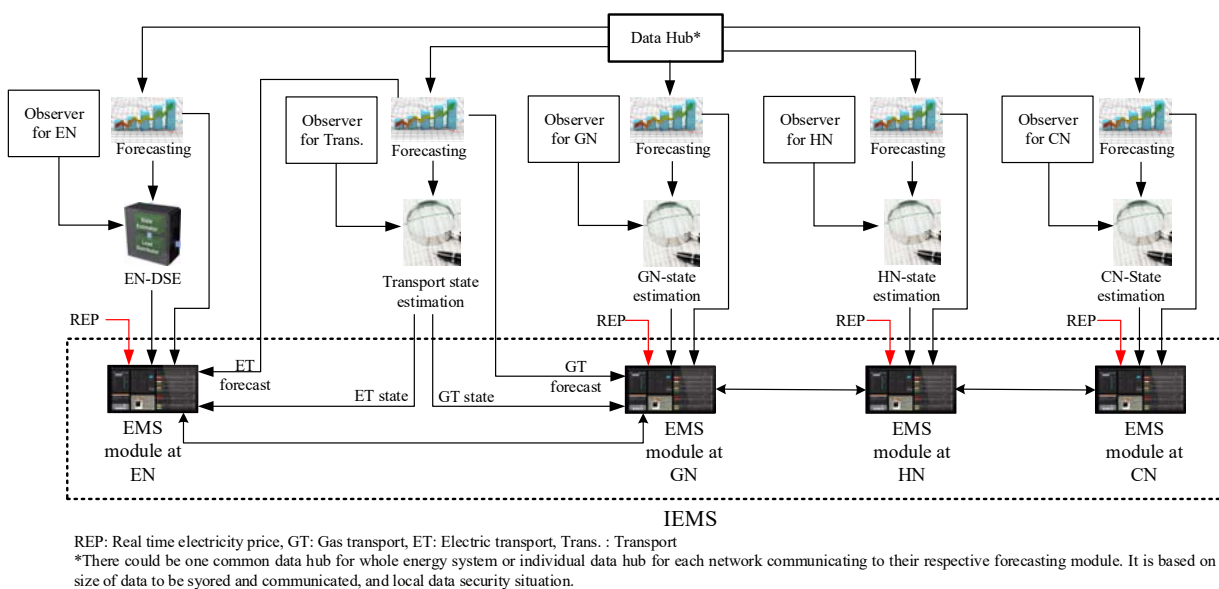

Fig. 6 Generic energy system observability architecture

1.3.2 Forecasting of load and generation for the energy system

The forecasting module is a generic or a high level module. Future load (electric, heating/cooling, gas), transport scenario, BESS – charging status etc. and generation (wind, solar, micro CHP, gas cogeneration, micro hydro, BESS - dispatching etc.) profiles for a given period are prepared using forecasting techniques and historical data. Based on the application of the forecasted profiles and selected forecasting techniques it can be calculated for various precision levels. To use such profiles for generation dispatching short-term forecasting techniques are used with weather forecast, historic load/generation statistics and social & technical events. Short term forecasting techniques having the flexibility to forecast multiple variables can be used for monitoring and coordinated control [25].

Prosumers (or aggregators on behalf of the costumers) need to forecast local consumption and generation to determine active demand and flexible generation capacity at their premises. Then they can prepare their offer and bid in the electricity market. It is essential for the EMS to have short term load and generation profiles in advance (for a day) to monitor and plan their operation for short term situations as well. Generations like hydro, fuel turbines, biogas, geothermal, and BESS status are predicted more accurately than fluctuating renewable generations. Forecasting from renewable generation (wind, solar) depends upon forecasted metrological data and their accuracy. Load data are dependent on historic consumption pattern, weather forecast and social events.

Interlink between each stakeholder and information flow for forecasting and its application is shown in Fig. 7. Historical records of consumption of loads (electrical, heat/cooling, gas), social events (festivals), weather forecast, technical events (maintenance schedule), usage history of transport, EV and BESS etc. will be stored in the data hub. Critical information like individual customer consumption patterns will be decoded (E.g.: lumping of loads to the closest node) to maintain the data security issue. Then it will be transferred to forecasting module. The algorithm will start and be processed here for the required level of accuracy and the forecasted information will be passed to the respective EMS and state observer/estimation modules. From each EMS this information will be forwarded to all control modules. Some of the forecasted information like

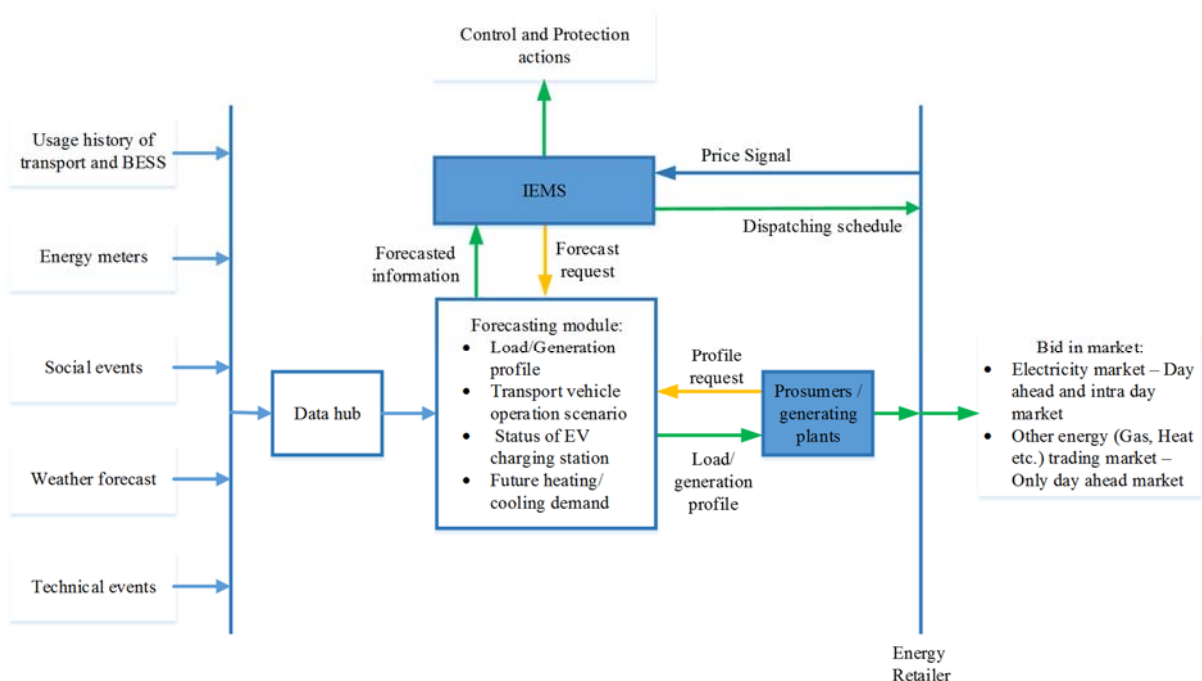

Fig. 7 Architecture for forecasting module for integrated energy system

load/generation profiles can be sent to prosumers and generation plants upon request so that they (for small prosumers via aggregator) can prepare offers and send bids to the market via the energy retailer.

1.3.3 State estimation

For the safe and reliable operation of an energy network close to real-time control and supervision is needed. In the electrical energy system, state estimation refers to the estimation of status of electrical network parameters like node voltage, line power flow and line current flow etc. Whereas the state estimation in the other network refers to the identification of the state of charge of BESS, number and location of transport vehicles, status of electric vehicle (EV) charging station, status of water, gas and heat in their respective networks etc. Monitoring of these network states close to real time is a key challenge. It is essential for network operators to know the state of their network in advance to monitor and plan their operation for short term situations. Each network utilities are the responsible bodies to perform this task in their respective network. Though smart energy meters will be installed in almost every node in future; processing of real time data from the large number of smart meters will be expensive and contain a high volume of data. So, like the SCADA (System control and data acquisition) in electricity transmission systems, the state estimation serves the purpose of knowing the actual condition of the energy distribution systems.

As seen in Fig. 8 network the topology data, system measurement data and forecasted information are the inputs to the state estimation module. If one set of variables in an actual network grid (normally bus voltage in EN) are known, then every other quantity about the actual grid system can be calculated based on them. So, system state determines the operating point of the energy system as a whole. The module will filter the data for any errors and execute the algorithm. Identified network states can be used to take control decision as well as to plan operation in short term situations.

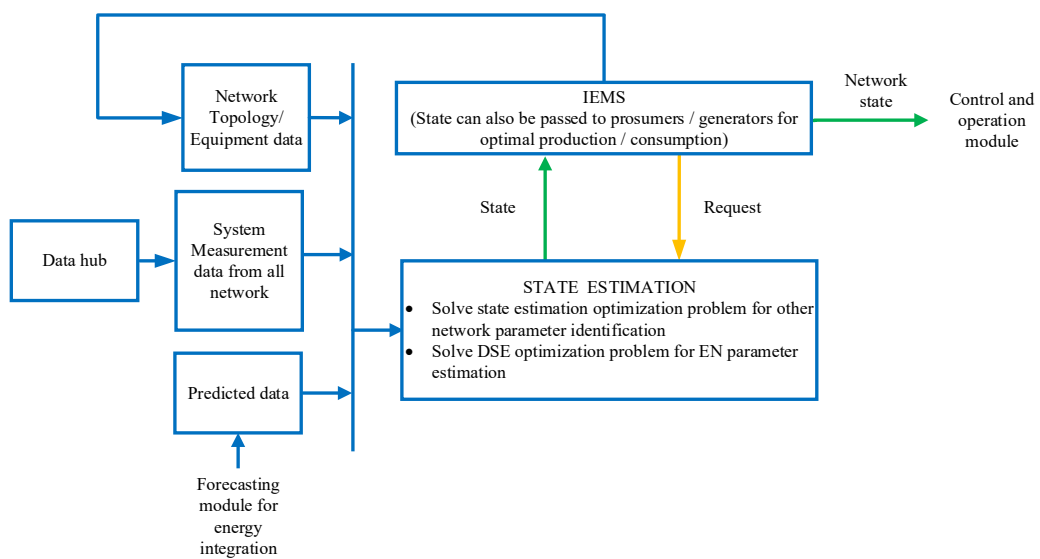

Fig. 8 High-level system architecture for real time monitoring of energy distribution systems

1.3.4 Integrated energy management system (IEMS)

System Operators in IES operate their respective network and records the generation and consumption by metering individual producers and consumers. The proposed IEMS is intended for the collective operation of different energy systems to coordinate all responsible distribution companies to ensure the delivery of their respective energy components to the end customer. The IEMS can be responsible for providing adequate grid capacity to bring the demanded energy to the final customers on the distribution levels for maintaining a certain energy quality. This has to be coordinated with energy market. Besides a stable local supply and generation control, the main challenge for the IEMS is to prevent bottlenecks in the energy distribution infrastructure. Such bottlenecks may be caused by the changing demand from end consumers or excessive power production from dispersed generation. Traditionally, congestion problems are overcome by physically expanding the energy network capacity.

IEMS is a platform, that can perform integrated analysis of energy efficiency, demand response and distributed generation (DG). As a result, each utility operator can take intelligent decisions. It can provide demand side management, real time monitoring & control and augments more renewables in the system. Due to IEMS, real time data (if required) will also be available in the system. The network model will be updated continuously and the system observer and state estimation as well as energy flow will be evaluated for each updated network. A more generic IEMS platform is required for the future grid. Elements of advanced observability and controllability of the active energy distribution network discussed in sections 1.3 and 1.4 respectively will have to be integrated at respective EMS under the respective IEMS platform. IEMS should ensure the combined operation of these modules in such way, that there should be minimum information exchange between different EMS to respect their individual data privacy.

1.4 Enhanced control of integrated energy systems

As discussed in the previous sections, the IES will be owned and operated by different entities and there is no central authority as such to manage the energy flow till now. A state of the art review of the IES and the challenges encountered in its integrated operation can be found in [26]. The components of the IES [18] are summarized into four categories in Fig. 9 namely, energy resources, conversion, storage and demand. However, Fig. 9 is not exhaustive and in practice, more components could be listed in each category. The energy obtained from the sources shown in Fig. 9 are not generally dispatchable and the energy demand in the three forms namely electricity, gas, and thermal (heating and cooling) have to be met. The objective of the IES control is to manipulate the energy conversion and storage shown in Fig. 9 to utilize energy from the sources in order to meet the energy

demand at all times [21]. The control algorithm should manage the addition or disconnection of units (say for example a CHP plant or wind power generator) from the energy conversion process and uncertainty in the energy production from renewable sources based on the weather conditions. The energy flow has to be managed such that the hosting capacity of the system assets are met and at the same time, total cost of operation of the IES is optimized. The above challenges can be tackled by having a proper control mechanism in place, which utilizes the information from observable blocks as discussed in the previous section. The dynamics of the different energy systems are quite different, which poses an additional challenge on the control. The costs of energy conversion and its storage are different for each form of energy, which leads to an economic optimization problem to be solved by the control algorithm to find the set points for the individual energy systems.

1.4.1 Design of Control Architecture

In view of the control challenges discussed above, the design methodology for the control of the IES has to support a modular control architecture. Concepts of distributed control methods and its application to electric power systems can be found in [27] and the references therein.

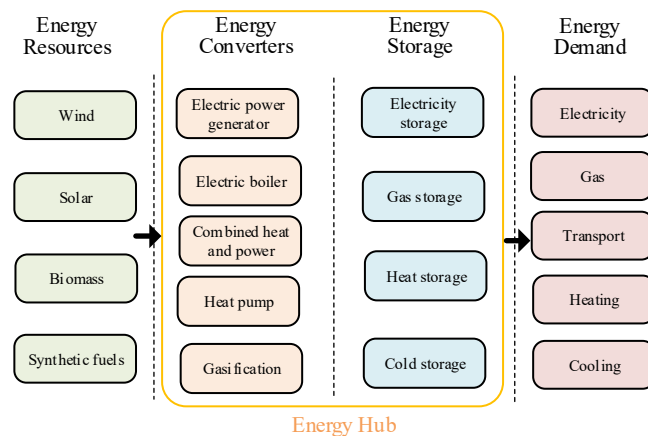

Fig. 9 Components of the integrated energy system

The two important characteristics required in the control of IES are flexibility and scalability [28], [23]. In literature, three types of control methods namely centralized, decentralized and distributed control methods are presented to control large scale systems such as IES. The layout of these control methods is shown in Fig. 10. The centralized control method requires a top authority to monitor and control the entire energy system. The scalability and flexibility of a centralized control architecture is limited in practice. The centralized control method is less reliable than other methods because failure of the controller or outage of communication channels will lead to unpredictable conditions. Decentralized control methods enables independent operation of each energy system without any communication among the systems. But the flexibility and coordination of multiple energy systems

are lost though this control method is cheaper to build and operate. Instead distributed control methods enables us to control individual energy systems by their respective controllers but in coordination with a central controller. The communication of information among the system controllers will be helpful to solve the problems locally without the intervention of the central controller. In the distributed control method, different entities can control their energy assets according to their business, performance, cost and reliability objectives, while taking into account the interdependencies among the other energy systems.

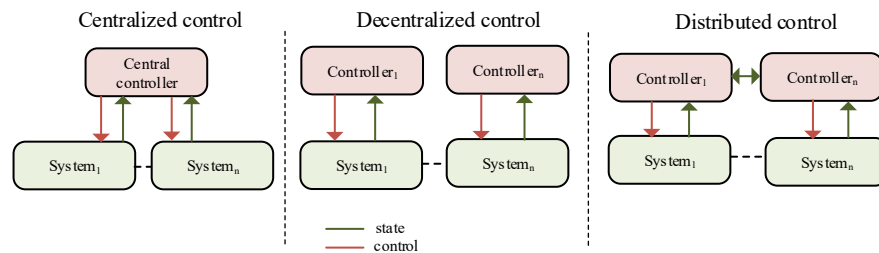

Fig. 10 Layout of centralized, decentralized and distributed control methods

Let us consider a distributed control architecture with the following properties:

- The control algorithm is based on a model based predictive control utilizing the forecasts of energy flows in the different energy networks.
- The control algorithm facilitates plug-and-play of units at the system level.

The coordinated operation of EMS allows individual monitoring of the state of each energy system, utilizes the forecasted information and compute the optimum energy flow among the different energy systems. The objective is to maintain a system level energy balance (between demand and production) and minimize the operating cost of the integrated energy system by utilizing the flexibility and storage at each energy system. In particular, this method is suitable for cases where the different systems are managed by different operators. The energy hubs are owned and controlled by different energy actors, commercial and residential customers retain control of their own assets and are willing to participate in the provision of ancillary services. The schematic of such an energy hub is shown in Fig. 11. The advantage of distributed control is that the individual optimization problems retain control of their assets and pursue their specific operational objectives. The optimization variables are exchanged for iterations with the central controller until the solution of the global optimization problem is reached. Each distributed controller dispatches the set points of the controllable energy resources after the optimization algorithm has converged.

1.4.2 Model of the Energy Systems

The energy systems are modelled based on the following assumptions.

- The dynamics of each energy system are ignored and it is assumed that they are in steady state and transients free.
- The losses occurring in the transmission lines of the energy networks can be linear approximated as their accuracy is not important compared to the conversion efficiencies among different energy systems.
- Energy storages are modelled as linear time-invariant systems ignoring the nonlinearities and internal losses.

The heating and cooling networks shown in Fig. 6 and Fig. 13 are combined as a thermal network in the following discussion. Let us define the following vectors: power sources $P_r = [P_{er} P_{gr} P_{tr}]^T$, power demands $P_d = [P_{ed} P_{gd} P_{td}]^T$, power input and output of energy conversion devices as $P_u = [P_{eu} P_{gu} P_{tu}]^T$ and $P_y = [P_{ey} P_{gy} P_{ty}]^T$ respectively, power input to the energy storage systems $P_s = [P_{es} P_{gs} P_{ts}]^T$. The index e, g and t in the above defined vectors represent the electrical, gas and thermal networks respectively. From Fig. 11(b), the input power is splitted into two parts based on the relation $P_r = P_u + P_{r1}$ using α as the splitting factor, where P_{r1} is the power from the sources fed directly to the load. The power demand is supplied from the output of energy conversion devices and the storage $P_d = P_{dy} + P_{dl}$ where, P_{dy} is the fraction of power output of energy conversion devices based on the factor β and P_{dl} is the net power output from energy storages based on the factor γ . The splitting factors (α , β , γ) are dimensionless numbers, which can be calculated from the optimization variables as discussed in the next section. In certain cases P_r and P_d could be negative, for example if a prosumer in the electrical network produces more electricity than his consumption and exports power to the electricity network. The power conversion happens at the energy hubs from one form of energy to another based on the relation $P_y = C_m \cdot P_u$, where C_m is the power conversion matrix [21] provided in (1.1).

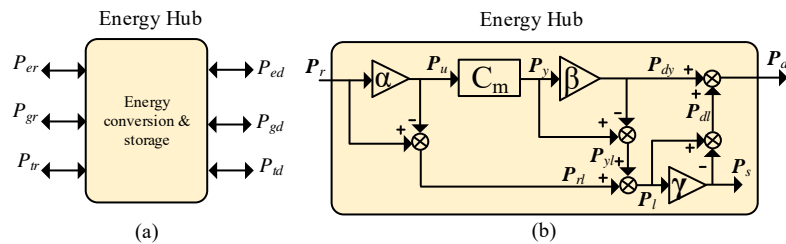

Fig. 11 (a) Schematic of an energy hub, (b) Power flow diagram in an energy hub

$$\begin{bmatrix} P_{ey} \\ P_{gy} \\ P_{ty} \end{bmatrix} = \begin{bmatrix} c_{ee} & c_{eg} & c_{et} \\ c_{ge} & c_{gg} & c_{gt} \\ c_{te} & c_{tg} & c_{tt} \end{bmatrix} \begin{bmatrix} P_{eu} \\ P_{gu} \\ P_{tu} \end{bmatrix} \quad (1.1)$$

The elements of the matrix C_m are either positive or zero. The elements of the above matrix provides the coupling among different energy systems, for example, c_{et} provides the efficiency of an electric boiler which converts the input electrical power to thermal energy. The net input power to the energy systems can be calculated from $P_s = \gamma(P_{rl} + P_{yl})$, where P_{yl} is the fraction of power output from energy conversion device which is supplied to the load. The energy storage system can be modeled as a linear time invariant system to find its dynamics.

1.4.3 Distributed Control Algorithm

In the energy system model described in the previous section, the control algorithm has to determine the input power to be drawn by the energy hub (P_r^*), power setpoints to the energy conversion devices (P_u^*) and power setpoints to the storage systems (P_s^*). In addition the power demand to be served from the output of energy conversion devices (P_{dy}^*) should also be computed. The above setpoints are calculated such that the power input to the energy hub and power stored/supplied in the energy storages are effectively utilized to meet the power demand at the output of the energy hub. The energy conversion matrix C_m can be assumed to be constant for a given configuration of the energy system. The splitting factors (α , β and γ) can be derived from the above power setpoints. These are calculated variables which are dependent on actual conditions such as state of charge, level of energy in the storages, level of charge for EVs etc. The above described control problem will be challenging for a large number of energy hubs with many energy conversion devices and energy storages. The flowchart shown in Fig. 12 can be used by each EMS to find power setpoints of the controllable assets (P_r^* , P_u^* , P_s^* , and P_{dy}^*) of each energy hub as follows.

At the start of each hour, each EMS solves its own optimization problem to find how much energy is required from other EMS. The required power values are sent to other EMS for acceptance. Upon receiving the power requests from other EMS, each EMS checks if it is possible to meet those power demand in addition to meeting its own power demand and network constraints. Each EMS sends back the information of how much the requested power demand can be met. Using this information, the optimization problem is then solved again to find the new power requests from other EMS. The above iteration is done until all the EMS reach an agreement on the power dispatch from respective networks. The below described algorithm can be implemented using a distributed control algorithm using decomposition techniques such as alternating-direction method of multipliers (ADMM) [29], [30].

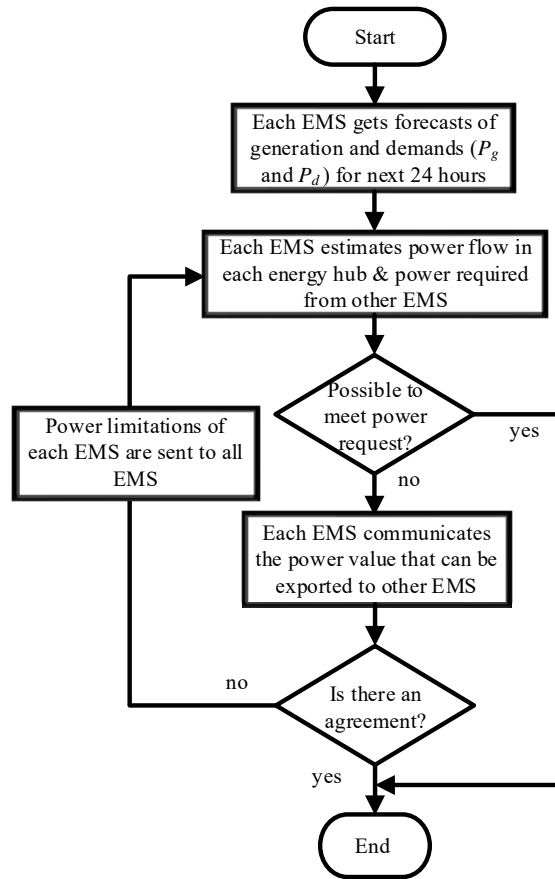

Fig. 12 Flowchart of control algorithm

1.5 Integrated energy system architecture for enhanced observability and controllability

A generic energy system network interconnection diagram to provide electricity, heat, gas, water and transport facilities to the end users is shown in Fig. 13. Physical interconnections should be modelled mathematically and designed appropriately. For the integrated operation of this multiple energy networks a control setup is required. Here, only interconnection of different energy system is shown. As discussed in earlier sections, there is a need of adding control architectural framework in order to have a coordinated operation for this set up.

Based on the design, modelling and discussion presented in the above sections a high level architecture for energy system integration for smart distribution is developed for the integrated operation of system as shown in Fig. 14. The concept of an energy hub is applied to optimally utilize the resources by switching the energy sources and demand based on the control set points received from respective EMS. The generic overview of observability modules, their interconnections with

different energy hubs and EMS, and basic signal flow is also shown. Therefore, to implement, the concept shown in figure 14 should be applied to the network shown in figure 13.

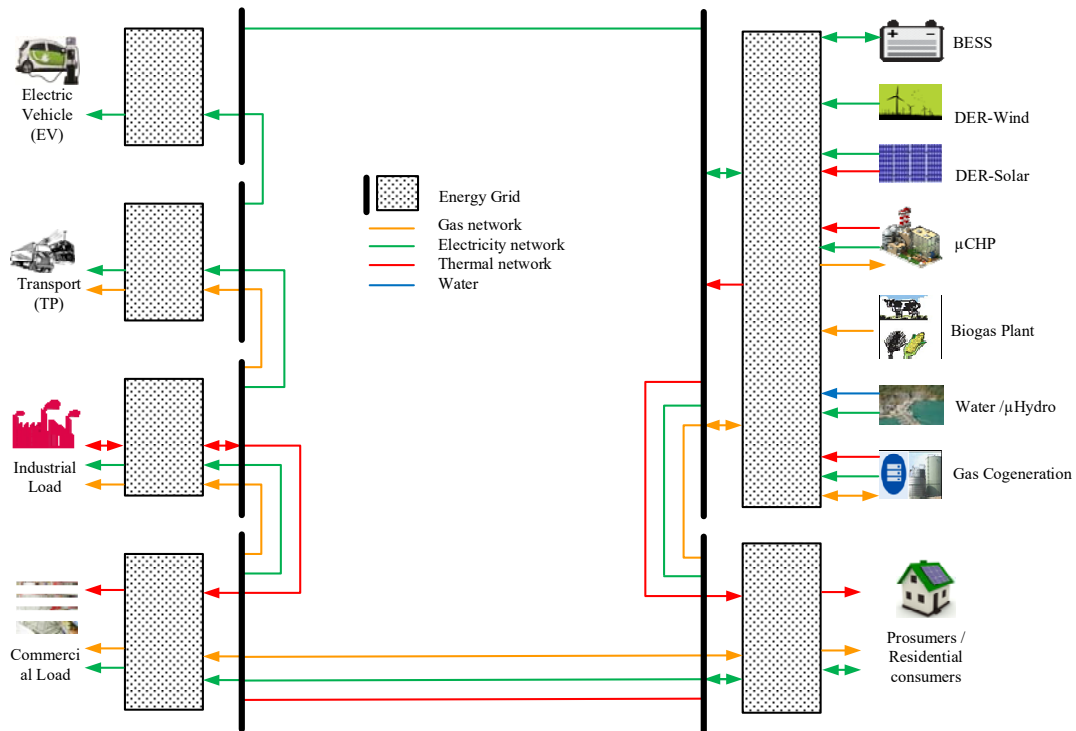

Fig. 13 Energy system network interconnections

For the effective implementation of this architecture, coordination of each EMS with their respective markets (gas market, electricity market etc.) is essential, because limited market coordination may lead to serious risks for flexibility. Recent blackouts in Texas in February 2011 due to insufficient stocks of natural gas in local storage and in southern Germany in February 2012 [31] due to lack of interdependence considerations of the gas/electricity system are some of the examples which encourages coordinated operation with markets. However, different energy market are often operated in isolation on different time frames but still coordinated operation is possible. Operators may do this by trading in a variety of markets via respective EMS.

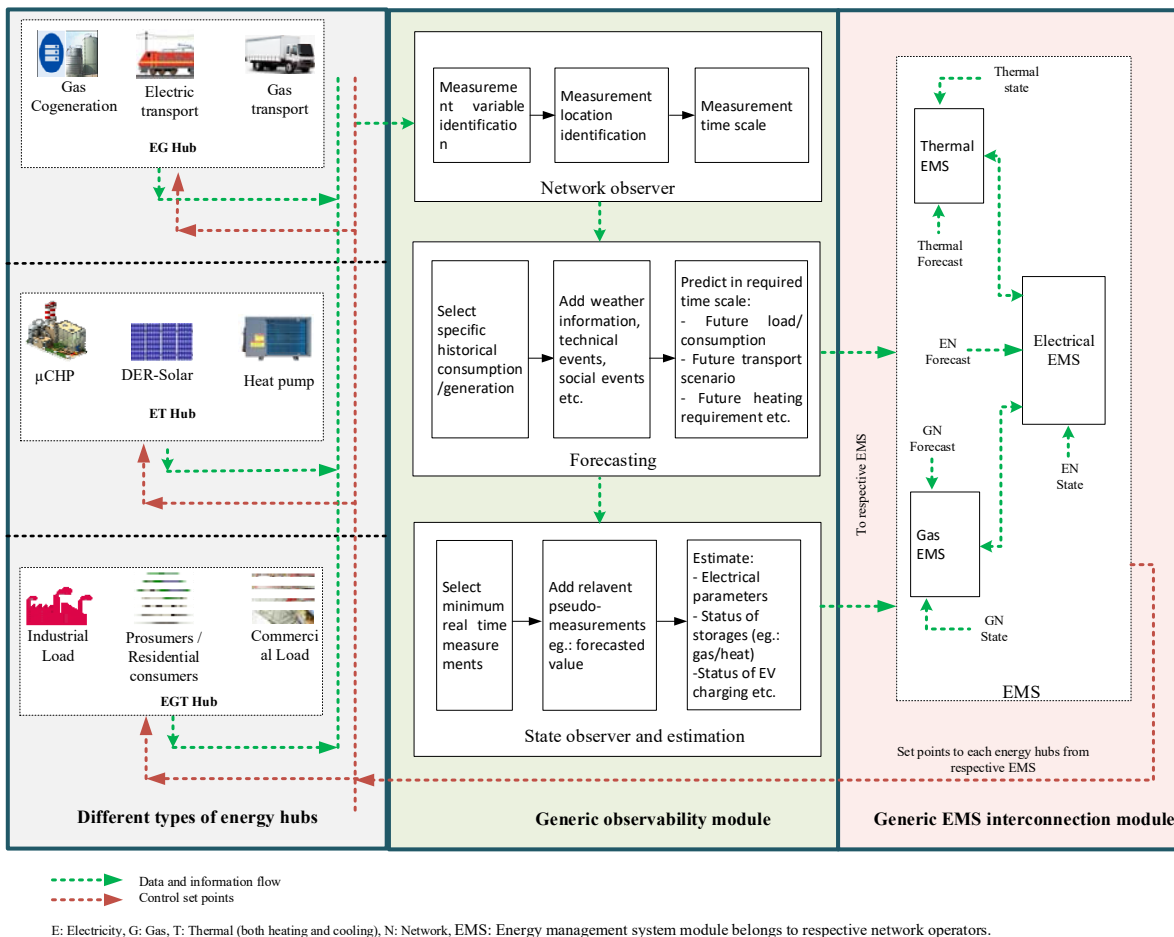

Fig. 14 High level architecture for energy system integration for smart distribution

1.6 Summary of the chapter

In this chapter, a high level system architecture for the intelligent energy system has been formulated taking into account all the major system components and associated actors. Various practical scenarios are highlighted for the enhanced observability and controllability of the integrated energy system network for active distribution. The interactions between the actors are illustrated and the basic integrated operation platform have been identified for detailed analysis. The above exercise will serve as inputs for the intelligent observability and controllability system design in active energy distribution network.

References

- [1] M. O'Malley, B. Kroposki, B. Hannegan, H. Madsen, M. Andersson, W. D'haeseleer, M. F. McGranaghan, C. Dent, G. Strbac, S. Baskaran, and M. Rinker, "Energy Systems Integration. Defining and Describing the Value Proposition," Golden, CO (United States), Jun. 2016.
- [2] C. Le Quéré and G. P. et. al. Peters, "Global carbon budget 2013," *Earth System Science Data*, 17-Jun-2014. [Online]. Available: <http://cdiac.ess-dive.lbl.gov/GCP/carbonbudget/2013/>. [Accessed: 19-Jul-2018].

- [3] “International Energy Outlook 2016-Executive Summary - Energy Information Administration.” [Online]. Available: https://www.eia.gov/outlooks/ieo/exec_summ.php. [Accessed: 17-Jul-2018].
- [4] D. Connolly, H. Lund, and B. V Mathiesen, “Smart Energy Europe: The technical and economic impact of one potential 100% renewable energy scenario for the European Union,” 2016.
- [5] IRENA, “Renewable Energy Prospects for the European Union,” 2018.
- [6] “Final energy consumption by sector and fuel — European Environment Agency.” [Online]. Available: <https://www.eea.europa.eu/data-and-maps/indicators/final-energy-consumption-by-sector-9/assessment-1>. [Accessed: 17-Jul-2018].
- [7] “Energy consumption in households - Statistics Explained.” [Online]. Available: http://ec.europa.eu/eurostat/statistics-explained/index.php/Energy_consumption_in_households. [Accessed: 17-Jul-2018].
- [8] “Vison for Smart Energy in Denmark: Resaerch, Development and Demonstration,” *Smart Energy Networks*, 2015.
- [9] J. Mortensen et. al., “The Smart Energy System: Asset mapping of Danish competencies across the value chain,” Coopenhagen, 2014.
- [10] M. Bailera, P. Lisbona, L. M. Romeo, and S. Espatolero, “Power to Gas projects review: Lab, pilot and demo plants for storing renewable energy and CO₂,” *Renew. Sustain. Energy Rev.*, vol. 69, pp. 292–312, Mar. 2017.
- [11] Vølund et.al., “DISTRICT ENERGY Energy Efficiency for Urban Areas,” 2016.
- [12] S. Werner, “International review of district heating and cooling,” *Energy*, vol. 137, pp. 617–631, 2017.
- [13] B. Rezaie, M. A. Rosen, B. Rezaie, and M. A. Rosen, “District heating and cooling: Review of technology and potential enhancements,” *Appl. Energy*, vol. 93, no. C, pp. 2–10, 2012.
- [14] C. Guille and G. Gross, “A conceptual framework for the vehicle-to-grid (V2G) implementation,” *Energy Policy*, vol. 37, no. 11, pp. 4379–4390, Nov. 2009.
- [15] V. Knap, R. Sinha, M. Swierczynski, D.-I. Stroe, and S. Chaudhary, “Grid inertial response with Lithium-ion battery energy storage systems,” in *2014 IEEE 23rd International Symposium on Industrial Electronics (ISIE)*, 2014, pp. 1817–1822.
- [16] R. Sinha, B. Bak-Jensen, and J. R. Pillai, “Impact Assessment of Electric Boilers in Low Voltage Distribution Network,” in *Proceedings of IEEE PESGM 2018*, 2018.
- [17] R. Sinha, B. Bak-Jensen, J. R. Pillai, and B. Møller-Jensen, “Unleashing Flexibility from Electric Boilers and Heat Pumps in Danish Residential Distribution Network,” in *Proceeding of CIGRE Session 2018*, 2018.
- [18] J. Mortensen, J. Flackeberg, A. Goul, and M. Johansen, “The Smart Energy System,” 2015.
- [19] H. Larsen, S. Hvidtfeldt, and L. Petersen, “Risø energy report 10 : Energy for smart cities in an urbanised world,” 2018.
- [20] Ministry of Transport, *The Danish Transport System*. 2012.
- [21] M. Geidl, G. Andersson, M. Geidl, and G. Andersson, “Optimal Power Flow of Multiple

Energy Carriers,” *IEEE Trans. Power Syst.*, vol. 22, no. 1, pp. 145–155, 2007.

- [22] B. R. Pokhrel, N. Karthikeyan, B. Bak-Jensen, and J. R. Pillai, “Intelligent architecture for enhanced observability for active distribution system,” in *2017 IEEE PES Innovative Smart Grid Technologies Conference Europe (ISGT-Europe)*, 2017, pp. 1–6.
- [23] E. Dall’Anese, P. Mancarella, and A. Monti, “Unlocking Flexibility: Integrated Optimization and Control of Multienergy Systems,” *IEEE Power Energy Mag.*, vol. 15, no. 1, pp. 43–52, Jan. 2017.
- [24] M. Muratori and G. Rizzoni, “Residential Demand Response: Dynamic Energy Management and Time-Varying Electricity Pricing,” *IEEE Trans. Power Syst.*, vol. 31, no. 2, pp. 1108–1117, Mar. 2016.
- [25] N. Karthikeyan, B. R. Pokhrel, J. R. Pillai, B. Bak-jensen, A. Jensen, T. Helth, J. Andreasen, and K. H. B. Frederiksen, “Coordinated Control with Improved Observability for Network Congestion Management in Medium-Voltage Distribution Grid,” in *Proceedings of CIGRE Session*, 2018.
- [26] H. Lund, P. A. Østergaard, D. Connolly, and B. V. Mathiesen, “Smart energy and smart energy systems,” *Energy*, vol. 137, pp. 556–565, 2017.
- [27] M. Et.al., “A Survey of Distributed Optimization and Control Algorithms for Electric Power Systems,” *IEEE Trans. Smart Grid*, vol. 8, no. 6, pp. 2941–2962, Nov. 2017.
- [28] J. Bendtsen, K. Trangbaek, and J. Stoustrup, “Hierarchical model predictive control for resource distribution,” *49th IEEE Conf. Decis. Control*, pp. 2468–2473, 2010.
- [29] S. Boyd, N. Parikh, E. Chu, B. Peleato, and J. Eckstein, “Distributed Optimization and Statistical Learning via the Alternating Direction Method of Multipliers,” *Found. trends Mach. Learn.*, vol. 3, no. 1, pp. 1–122, 2011.
- [30] A. J. Conejo, E. Castillo, R. Minguez, and R. Garcia-Bertrand, *Decomposition Techniques in Mathematical Programming*, vol. 53. 2006.
- [31] S. Heinen, C. Hewicker, N. Jenkins, J. McCalley, M. O’Malley, S. Pasini, and S. Simoncini, “Unleashing the Flexibility of Gas: Innovating Gas Systems to Meet the Electricity System’s Flexibility Requirements,” *IEEE Power Energy Mag.*, vol. 15, no. 1, pp. 16–24, Jan. 2017.

ISSN (online): 2446-1636
ISBN (online): 978-87-7210-464-5

AALBORG UNIVERSITY PRESS