



Aalborg Universitet

AALBORG UNIVERSITY  
DENMARK

## Fractional-Order Control Techniques for Renewable Energy and Energy-Storage-Integrated Power Systems

*A Review*

Alilou, Masoud; Azami, Hatef; Oshnoei, Arman; Mohammadi-ivatloo, Behnam; Teodorescu, Remus

*Published in:*  
Fractal and Fractional

*DOI (link to publication from Publisher):*  
[10.3390/fractalfract7050391](https://doi.org/10.3390/fractalfract7050391)

*Creative Commons License*  
CC BY 4.0

*Publication date:*  
2023

*Document Version*  
Publisher's PDF, also known as Version of record

[Link to publication from Aalborg University](#)

*Citation for published version (APA):*

Alilou, M., Azami, H., Oshnoei, A., Mohammadi-ivatloo, B., & Teodorescu, R. (2023). Fractional-Order Control Techniques for Renewable Energy and Energy-Storage-Integrated Power Systems: A Review. *Fractal and Fractional*, 7(5), Article 391. <https://doi.org/10.3390/fractalfract7050391>

### General rights

Copyright and moral rights for the publications made accessible in the public portal are retained by the authors and/or other copyright owners and it is a condition of accessing publications that users recognise and abide by the legal requirements associated with these rights.

- Users may download and print one copy of any publication from the public portal for the purpose of private study or research.
- You may not further distribute the material or use it for any profit-making activity or commercial gain
- You may freely distribute the URL identifying the publication in the public portal -

### Take down policy

If you believe that this document breaches copyright please contact us at [vbn@aub.aau.dk](mailto:vbn@aub.aau.dk) providing details, and we will remove access to the work immediately and investigate your claim.



Review

# Fractional-Order Control Techniques for Renewable Energy and Energy-Storage-Integrated Power Systems: A Review

Masoud Alilou <sup>1</sup>, Hafez Azami <sup>1</sup>, Arman Oshnoei <sup>2</sup>, Behnam Mohammadi-Ivatloo <sup>1,3,\*</sup> and Remus Teodorescu <sup>2</sup>

<sup>1</sup> Faculty of Electrical and Computer Engineering, University of Tabriz, Tabriz 51666-16471, Iran; masoud.alilou@yahoo.com (M.A.); hatef.azami1992@gmail.com (H.A.)

<sup>2</sup> Department of Energy, Aalborg University, 9220 Aalborg, Denmark; aros@energy.aau.dk (A.O.); ret@energy.aau.dk (R.T.)

<sup>3</sup> Department of Electrical Engineering, School of Energy Systems, LUT University, 53850 Lappeenranta, Finland

\* Correspondence: mohammadi@ieee.org

**Abstract:** The worldwide energy revolution has accelerated the utilization of demand-side manageable energy systems such as wind turbines, photovoltaic panels, electric vehicles, and energy storage systems in order to deal with the growing energy crisis and greenhouse emissions. The control system of renewable energy units and energy storage systems has a high effect on their performance and absolutely on the efficiency of the total power network. Classical controllers are based on integer-order differentiation and integration, while the fractional-order controller has tremendous potential to change the order for better modeling and controlling the system. This paper presents a comprehensive review of the energy system of renewable energy units and energy storage devices. Various papers are evaluated, and their methods and results are presented. Moreover, the mathematical fundamentals of the fractional-order method are mentioned, and the various studies are categorized based on different parameters. Various definitions for fractional-order calculus are also explained using their mathematical formula. Different studies and numerical evaluations present appropriate efficiency and accuracy of the fractional-order techniques for estimating, controlling, and improving the performance of energy systems in various operational conditions so that the average error of the fractional-order methods is considerably lower than other ones.

**Keywords:** control methods; energy systems; renewable energy sources; energy storage systems; fractional-order system



**Citation:** Alilou, M.; Azami, H.; Oshnoei, A.; Mohammadi-Ivatloo, B.; Teodorescu, R. Fractional-Order Control Techniques for Renewable Energy and Energy-Storage-Integrated Power Systems: A Review. *Fractal Fract.* **2023**, *7*, 391. <https://doi.org/10.3390/fractalfract7050391>

Academic Editor: Norbert Herencsar

Received: 27 March 2023

Revised: 5 May 2023

Accepted: 7 May 2023

Published: 9 May 2023



**Copyright:** © 2023 by the authors. Licensee MDPI, Basel, Switzerland. This article is an open access article distributed under the terms and conditions of the Creative Commons Attribution (CC BY) license (<https://creativecommons.org/licenses/by/4.0/>).

## 1. Introduction

Population growth, climate change, and increasing electricity demand have driven governments to utilize novel energy management systems such as microgrids (MGs) and smart grids (SGs) instead of traditional power networks [1]. MGs support a flexible and efficient power network by enabling the integration of renewable energy sources (RESs) instead of conventional power plants [2,3]. Moreover, the management of green-energy-supporting technologies such as electric vehicles (EVs) and energy storage systems (ESSs) is more straightforward in small SGs [4,5]. The use of local energy units reduces energy losses in transmission and distribution systems and increases the efficiency and quality of the electricity system. Although renewable sources have lower carbon losses and their energy is available in most parts of the earth, their energy is stochastic and variable during the day and year [6,7]. Electrical storage systems are the solution for stabilizing the produced energy from renewable sources. Electric vehicles, the main system of which is a storage system, are other practical technologies for reducing air pollution and increasing social welfare [8]. In recent years, considerable development of renewable resources and energy

storage systems has been achieved due to the promotion of technologies of MGs, SGs, and also EVs.

Modeling, estimating, and controlling the utilized devices such as renewable energy sources and energy storage systems in microgrids are important and complex. Fractional-order methods are a practical way to enhance energy system performance [9,10]. The FO calculus can be used in integer-order and non-integer-order models [11], and the results of the previous studies have proved that fractional-order techniques are very suitable and flexible ways to characterize the properties in various energy processes [12]. So far, researchers and operators have modeled many practical systems in energy fields such as wind turbines [13], hydro-turbine governing systems [14], chaotic systems [15], energy supply–demand systems [16], permanent magnet synchronous generator systems [17], and microgrids [18] by using fractional-order equations. The FO methods also have proper performance in the estimation of parameters of energy systems [19], especially in energy storage systems, the characteristics of which such as the state of charge [20], state of energy [21], state of health [22], and state of temperature [23] are particularly important to estimate for maintaining the safe and efficient operation of storage systems. Controlling the energy system's process, which causes the system's performance to remain unchanged, is another practical application of fractional-order methods [24,25]. The FO techniques are utilized to control various performance parameters of energy systems, such as voltage [26], current [27], power [28], temperature [29], and cost [30]. Engineers use fractional-based controllers to control the practical energy systems of different technologies such as wind turbines [31], photovoltaic panels [32], electric vehicles [33], and storage systems [34].

In recent decades, the tendency and motivation to utilize low-carbon and renewable power resources have increased considerably due to the rareness of fossil fuels and increased environmental problems. According to statistical data on world energy in 2022, more than one-third of the consumed electricity was approximately generated by low-carbon units including hydropower, nuclear, solar, and wind generations [35,36]. Renewable resources are expected to play a larger role in electricity generation in the coming years, facilitated by the use of microgrids (MGs), smart grids (SGs), and smart homes (SHs) [37]. It should be considered that due to the stochastic performance of renewable resources, their control and management systems have a high impact on their performance and the efficiency of the total power network. Renewable energy resources exhibit significant fluctuations in power generation due to the unpredictable nature of their primary energy source. Their stochastic behavior affects the power quality, frequency, and voltage of the power network [38]. The produced stochastic power of RESs and the necessity of utilization of ESSs in the power system introduce new controlling and management challenges. The utilization of the appropriate control technique has a high effect on the optimal performance of the renewable units and the power network [39]. In other words, the high penetration rate of green technologies presents critical problems for power systems. Control programs are an important way to resolve this problem in which frequency fluctuation and other dangerous issues are observable. Control methods such as fractional-order proportional integral derivative (FOPID) [40,41], fractional-order cascade controller [42], proportional integral (PI) [43], proportional derivative (PD) [44], proportional integral derivative (PID) [45], fuzzy methods [46,47], model predictive control (MPC) [48,49], tilted integral derivative (TID) [50], and a hybrid method of TID and FOPID [51] have been utilized in different studies for improving the efficiency of renewable energy systems. Moreover, these control methods have been implemented for improving the inertia of the power system when various low and high disturbances occur in the devices and systems. Fractional-order (FO) control methods are also used for power converters in renewable energy systems. This flexible control and power converter technique decreases the overshoot level and settling time and increases the rising time. Fractional-order controllers have better dynamics, steady-state error, and stability than traditional controllers such as PI, PD, and PID. Moreover, the efficiency of the fractional-order controller, which can be defined as the

ratio of the controlled output parameter to the input parameter, is higher than that of the other ones [52].

ESSs are employed to enhance the stability of the overall power system by bridging the gap between energy generation and consumption. Moreover, they are used in EVs to provide the required power for the vehicle. The energy storage systems technologies can be divided into four groups: electrical ESS, electrochemical ESS, electromechanical ESS, and thermal storage system [53,54]. Lithium-ion batteries (LIBs) and supercapacitors are among the most commonly utilized ESSs in MGs and EVs. The long lifetime, low self-discharge rate, and high energy and power density are the most highlighted advantages of LIBs. On the other hand, shortcut problems and heat-runaway are one of their disadvantages. To increase their performance and prevent problems, reliable situation estimation is so essential. Supercapacitors or ultra-capacitors are powerful energy storage devices with more abilities than batteries and capacitors. They can be charged more than capacitors and discharge more power than batteries [55,56]. The control and management systems of energy storage devices are developed to control and monitor the different parameters such as the state of charge (SOC), state of power (SOP), and state of health (SOH) in order to ensure the safety and reliability of the storage system [57]. The battery's SOC presents the battery's available stored energy, while the SOP shows the rate of the battery working in extreme conditions [58,59]. The SOH of the storage system indicates its degradation and remaining capacity. In other words, this index compares the remaining charge of the storage system with its rated value [60]. The stability and robustness of the estimation value of each of these parameters are required for appropriately modeling the storage system [61]. The accurate estimation of the ESS's situation is crucial for its proper management. Although different methods such as artificial neural networks (ANNs) [62], the support vector machine [63], the learning machine [64], fuzzy logic [65], the open circuit voltage method [66], and ampere-hour integration [67] have been used for predicting the ESSs, three techniques including the electrochemical model [68], integer-order model [69], and fractional order [70] are more commonly utilized methods. The integer-order model, called the equivalent circuit model, considers resistance capacitance systems [69]. The electrochemical model presents differential algebraic formulas about the intern electrochemical reactions of the storage device [68]. The FO model, which is more complete and effective than these two methods, considers the electrochemical characteristics without considering the equivalent circuit model. This method considers the fractional impedances, including the constant phase element (CPE) and Warburg element [70]. The FO model has more stability than traditional methods and finds the proper results in a lower time. Therefore, it can be applied to online and real applications.

Figure 1 demonstrates a comprehensive structure of fractional-order methods in systems of renewable energy systems and energy storage systems. As can be shown in this figure, fractional-order methods have been utilized in renewable energy systems of WTs, PVs, geothermal systems, and some hybrid systems. In these systems, different fractional-based systems such as FOPID, FOPD, FO-TID, and FOI-TD have been investigated. In energy storage systems, the majority of fractional-order systems have been applied on LIBs, LMBs, SMESSs, and supercapacitors. The application of fractional-based systems in ESSs can be divided into three main categories including modeling, estimating, and controlling. Based on the formulation, four definitions including GLD, RLD, CD, and OSD are most utilized in fractional-order systems. Some assistive techniques are used in the fractional-order method to improve its performance. In the following, the details of different applications, definitions, objectives, and assistive techniques of fractional-order methods are presented.

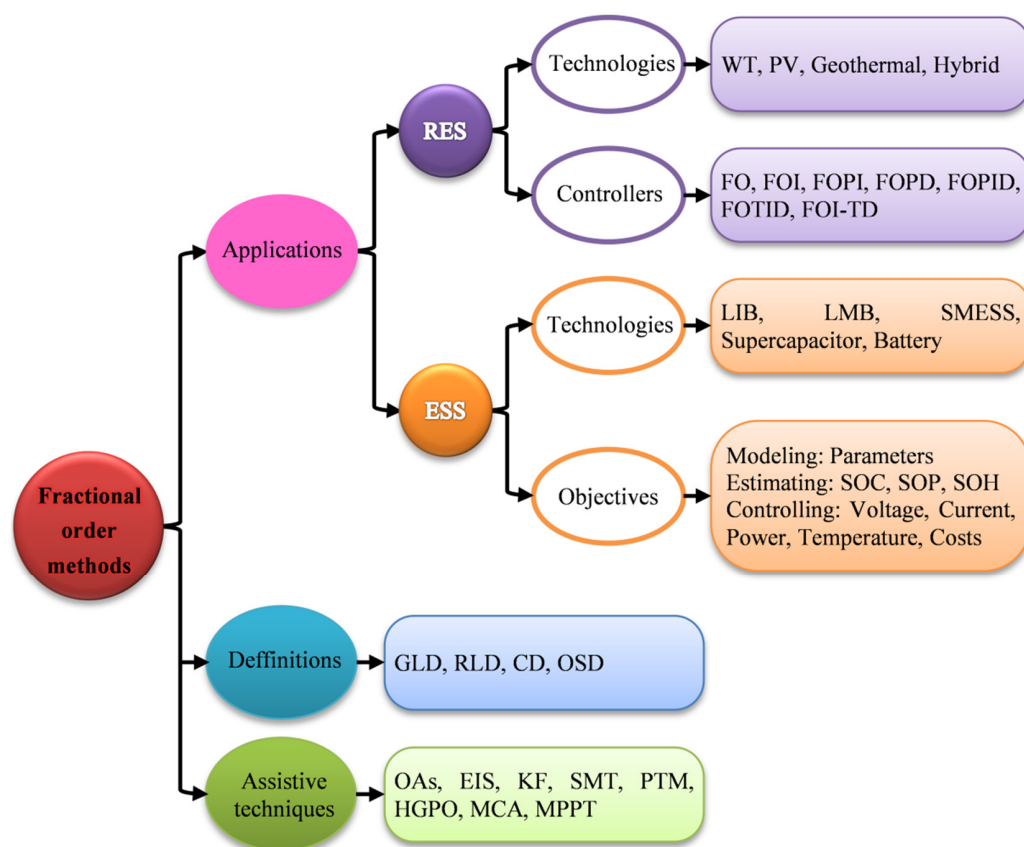

**Figure 1.** Comprehensive structure of FO methods in energy systems of RESs and ESSs.

### 1.1. Motivations

Although in recent years, some authors considered fractional-order techniques for modeling, estimating, and controlling the energy systems of RESs and ESSs and modifying their performance, there was no overall research on applications of FO methods on the energy systems of these devices. For this reason, it motivated us to prepare an overview of previous studies on fractional-order methods and the energy systems of RESs and ESSs. Moreover, we wanted to present a framework of important formulations and definitions of FO techniques that can be applied to practical and experimental energy systems for researchers and engineers. On the other hand, RESs and ESSs appropriately complement each other in the power network so that RESs inject renewable and eco-friendly energy into ESSs while ESSs increase the stability and quality of the produced energy of RESs. It was another reason to prepare a review paper about applications of FO techniques in both RESs and ESSs so that readers can easily see the advantages and disadvantages of FO-based estimating, modeling, and controlling methods of RESs and ESSs in a comprehensive article. In other words, we present important details of the latest articles about applications of fractional-order methods in RESs and ESSs, such as objectives, optimization methods, electrical circuit models, identification methods, remarkable numerical results, advantages, and disadvantages, in this review paper in order to comprehensively evaluate the performance of FO methods in energy systems of renewable units and storage devices. Thus, the main motivations of this review paper are as follows:

1. Providing a detailed explanation of fractional-order control techniques and their applications in renewable energy and energy-storage-integrated power systems.
2. Summarizing the current research findings on the use of fractional-order control techniques in these systems, including their advantages and limitations.
3. Comparing and evaluating different fractional-order control techniques used in renewable energy and energy-storage-integrated power systems based on their performance and applicability.



4. Identifying challenges and opportunities for future research in this field and suggesting possible directions for further investigation.

### 1.2. Methodology

To extract appropriate and adequate resources for evaluating the applications of FO methods in RESs and ESSs, published papers in the last decade that have considered FO techniques for estimating, modeling, and controlling the energy systems of RESs and ESSs were gathered from international scientific databases, such as IEEE and ScienceDirect. Some important and practical keywords, such as fractional-order controllers, estimation methods, modeling techniques, renewable sources, energy storage systems, photovoltaic panels, wind turbines, electrochemical impedance spectroscopy, lithium-ion battery, parameter identification, and state of charge were considered for selecting the proper and related papers. After reviewing these articles, the papers with high relevance to the applications of FO methods in RESs and ESSs were divided into two main categories, including renewable energy systems and energy storage systems, for more detailed evaluations. The explanations of the proposed method, the application of the fractional-order technique in the energy system, the utilized equations, objectives, constraints, assistive techniques, numerical results, and the comparison data with other methods are the extracted details from the reviewed articles. They are explained and categorized in the following sections. Moreover, the formulations and methods of some papers are considered for simulation and evaluation of the FO methods, and simulation results are presented and explained using figures and tables.

Therefore, in this review paper, after presenting the main formulations of FO methods in the energy systems, previous studies about FO methods that have been utilized in the energy systems of RESs and ESSs are considered for reviewing FO controllers and systems. These studies are divided into two sections, including (a) fractional-order techniques and renewable energy systems and (b) fractional-order techniques and energy storage systems. The papers of each section are evaluated deeply based on the methods, objectives, advantages, and disadvantages. Moreover, their details, such as the models, type of controllers, optimization methods, electrical circuits, identification methods, and objectives, are also categorized and summarized for easy access to an overview of applications of FO methods in the energy systems of RESs and ESSs. After pondering different studies, some suggestions for future research on FO methods are presented. Table 1 presents a summary of the remaining sections in this paper, with the key objectives of each section.

**Table 1.** Summary of the sections in this paper.

Sections	Objectives
2. Fractional-order systems	Mathematical formulation of FO systems, Definitions of FO operators, FO controller, FO-based converters and inverters
3. Fractional-order techniques and renewable energy sources	Applications of FO methods in RESs, description of different methods, Evaluation of numerical results, Discussion about the effect of FO methods on the energy system of RESs
4. Fractional-order techniques and energy storage systems	Applications of FO methods in ESSs, explanation of various techniques, Evaluation of numerical results, Discussion about the advantages and disadvantages of FO methods in the energy system of ESSs
5. Future perspectives	Future perspective on FO methods, Presenting some suggestions for future works on fractional-order systems
6. Conclusion	Conclusion of the literature review and summary of advantages and disadvantages of FO methods

## 2. Fractional-Order Systems

In this section, an overall description of FO techniques, which are used in energy systems for controlling, is explained. Fractional-order techniques are applied in dynamic systems to model their operation by a fractional differential equation considering a non-integer derivative. To describe the objects of the considered system as fractal properties, integrals and derivatives of fractional orders are utilized [71,72]. In recent years, the growth of engineering systems, technologies, and science has led to the implementation of FO models in many dynamic systems such as electrochemistry systems [73], physics systems [74], viscoelasticity systems [75], biological systems [76], and chaotic systems [77] for different purposes such as controlling [78], observing [79], estimating [80], and stabilizing [81].

The FO operator is mathematically defined in Equation (1). This operator describes the dynamic processes of the system with infinite dimensions.

$${}_a D_t^\beta = \begin{cases} \frac{d^\beta}{dt^\beta} & \beta > 0 \\ 1 & \beta = 0 \\ \int_a^t (d\tau)^\beta & \beta < 0 \end{cases} \quad (1)$$

Here,  $\beta$  shows the order of the fractional operator, while  $a$  and  $t$  are the bounds of the operation. The value of the order of the fractional operator is variable in the real number domain ( $\beta = 1, 2, 3, \dots$ ).

### 2.1. Fractional-Order Definitions

Most definitions of the fractional integrals and derivatives, which facilitate numerical evaluations and analysis, are the Grünwald–Letnikov definition (GLD), the Riemann–Liouville definition (RLD), and the Caputo definition (CD) [82]. The mathematical descriptions of the most used definitions are presented in the following.

Grünwald–Letnikov definition: The GLD as the most utilized method presents a unique form of fractional calculus. Mathematically, this definition is mentioned in Equation (2) [83].

$${}_a D_t^\beta f(t) = \lim_{h \rightarrow 0} \frac{1}{h^\beta} \sum_{j=0}^{\infty} (-1)^j \binom{\beta}{j} f(t - jh) \quad (2)$$

In this equation, the symbol  $h$  is the sampling interval, and  $\binom{\beta}{j}$  is the binomial coefficients, which can be calculated by using Equation (3).

$$\binom{\beta}{j} = \begin{cases} \frac{\beta!}{j!(\beta-j)!} = \frac{\Gamma(\beta+1)}{\Gamma(k+1)\Gamma(\beta-j+1)} & j > 0 \\ 1 & j = 0 \end{cases} \quad (3)$$

Here,  $\Gamma(k)$  is the gamma function. Equation (4) shows this function.

$$\Gamma(k) = \int_0^{\infty} e^{-x} x^{k-1} dx \quad (4)$$

To calculate the coefficient  $(-1)^j \binom{\beta}{j}$ , a recursive method is utilized to simplify the complex process. This approach is shown in Equation (5).

$$\begin{cases} (-1)^j \binom{\beta}{j} = 1 & j = 0 \\ (-1)^j \binom{\beta}{j} = \left(1 - \frac{\beta+1}{j}\right) [(-1)^{j-1} \binom{\beta}{j-1}] & j > 0 \end{cases} \quad (5)$$

Riemann–Liouville definition: The RLD, which is named after Bernhard Riemann and Joseph Liouville, is another method for presenting the possibility of fractional calculus. This definition is shown mathematically in Equation (6) [84].

$${}_a D_t^\beta f(t) = \frac{1}{\Gamma(N - \beta)} \left( \frac{d}{dt} \right)^\beta \int_\beta^t \frac{f(\tau)}{(t - \tau)^{\beta - N + 1}} d\tau \quad (6)$$

This equation considers  $(N - 1 \leq \beta \leq N)$ . Here,  $N$  is an integer parameter.

Caputo definition: This definition is almost similar to the RLD, but the derivative element is not in the CD. Equation (7) presents the mathematical form of this definition considering the condition  $(N - 1 \leq \beta \leq N)$  [85].

$${}_a D_t^\beta f(t) = \frac{1}{\Gamma(N - \beta)} \int_\beta^t \frac{f(\tau)}{(t - \tau)^{\beta - N + 1}} d\tau \quad (7)$$

Oldham and Spanier definition (OSD): Oldham and Spanier introduced a definition in 1974 for presenting fractional calculus. This mathematical definition is shown in Equation (8).

$$\frac{d^q(\beta x)}{dx^q} = \beta^q \frac{d^q(\beta x)}{d(\beta x)^q} \quad (8)$$

where  $\beta$  function is defined as bellow:

$$\beta(m, n) = \int_0^1 (1 - x)^m x^{n-1} dx \quad m, n \in \mathbb{R} \quad (9)$$

Other definitions of fractional-order calculus can be studied in [86].

## 2.2. Fractional-Order Controller

The controllers have been improved in both industry and academic systems during recent years, and they have become more advanced and complex. The FOPID controllers have received great attention in previous years. However, simple tuning rules and no effectiveness still exist for FOPID controllers such as those specified for the integer PID controllers [87]. The PID controllers are mostly utilized in industrial applications due to their functional simplicity. On the other hand, the parameters of PID controllers are often adjusted using tests, experience, or error methods. Although this adjusting process can be applied easily in academic systems, it is definitely difficult to use to calculate the controller's gain in an industrial system because most industrial systems have some difficulties, such as uncertainties, nonlinearities, and structural complexity [88].

The variant of the fractional order including PD, PID, FOPID, and tilted integral derivative (TID) is presented explicitly in [89]. This paper defines the most usable commande robuste d'ordre non-entier approximation besides the FOPID controller by using Equation (10) [89].

$$S^a = C \prod_{i=1}^n \frac{1 + \left( \frac{s}{\omega_{z,i}} \right)}{1 + \left( \frac{s}{\omega_{p,i}} \right)} \quad (10)$$

The PID controller is the most popular and applicable shape of the controller, but FOPID is proposed according to the domain of variations. The FOPID has more stability than the PID controller. Moreover, the FO-based controller is more practical in complex problems with various parameters [90]. In Figure 2, the structure of the PID controller is demonstrated. According to this figure, the transfer function of fractional-order PID is presented in Equation (11) [90].

$$C(s) = K_p + K_d S^\beta + \frac{K_I}{S^\alpha} \quad (11)$$



By particular values of  $\alpha$  and  $\beta$ , conventional controllers are reachable. If  $\alpha = 0$  and  $\beta = 0$ , the values can be adjusted on the proportional controller. If  $\alpha = 0$  and  $\beta = 1$ , the PD controller is implemented although, in the PI controller, the value of these parameters are  $\alpha = 1$  and  $\beta = 0$ . Finally, if  $\alpha \in \mathbb{R}$  and  $\beta \in \mathbb{R}$ , the FOPID controller can be reached with a flexible character [91]. Therefore, the FOPID controller has more flexibility. Moreover, the integral of time error is optimized by manipulating controller parameters and intercepting fuzzy logic. In [92], a novel fractional-order controller with two free degree orders is introduced by utilizing a combination of the genetic algorithm (GA) and the artificial bee colony (ABC) algorithm. The tilted integral derivative is constructed by replacing the proportional section of PID with  $\frac{1}{S^n}$ . TID is powerful enough to reduce or reject disturbance and noise [93].

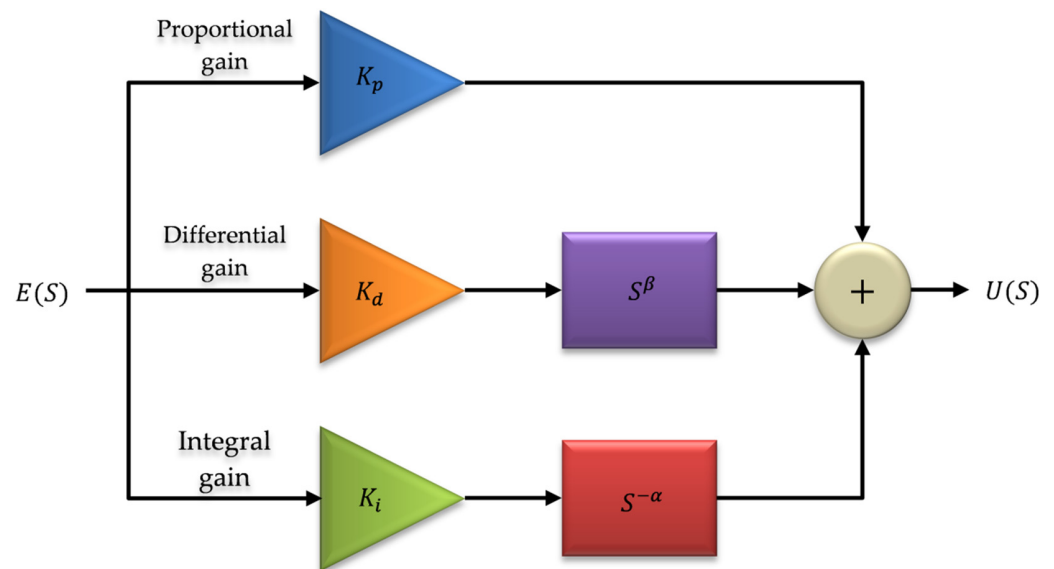

**Figure 2.** Structure of fractional-order PID controller.

### 2.3. Fractional Order in the Converters and Inverters

In the last decade, researchers have published papers about the application of FOPID and its variants in converters and inverters. As noticed, power electronics is an inevitable part of the power system and is used in a wide range of power systems such as renewable energy, high voltage DC, the drive of motors, etc.

#### 2.3.1. DC-DC Converters

The author of [94] concluded positive results from the effects of FOPID and conventional controllers in improving buck–boost converter transient efficiency. In that paper, the results represented rise time, steady-state situation, and overshoot improvement in the FOPID case study. In [95], the authors investigated the impacts of FOPID in the DC-DC converter. In that study, by using biquadratic approximation, it was concluded that non-integer controllers are flexible and offer faster responses and more stable situations than other controllers.

The authors of [96] presented a novel cascade controller for buck–boost DC-DC converters. The cascade controller contains two loops while the outer loop has a FOPID controller with a voltage-controlling role. In that paper, the inner loop operates using feedback from the outer loop. The ant lion optimization was used for adjusting FOPID parameters. This optimization algorithm has significant advantages compared to other algorithms such as PSO. The results demonstrate that the proposed approach could strive for a high-rate variation of dynamic performance. In [97], an FO-based controller was investigated to increase the stability and decrease the effects of harmonics. In that paper, a FOPID-based buck converter on RLD is modeled. The ultimate figure of the continu-

ous conduction mode in the steady-state situation shows that the parameters of the FO controller are reachable, stable, and robust.

### 2.3.2. AC-AC Inverters

The authors of [98] added a FOPID controller to an asymmetrical cascaded H-bridge multi-level inverter and compared it with conventional controllers. The results show an output voltage of the inverter with a considerable reduction in harmonic distortion. In [99], a multi-functional inverter was proposed for regulating the voltage and frequency of a photovoltaic energy storage system. In that paper, a shunt active power filter is utilized to mitigate harmonic content. Moreover, a virtual synchronous machine is considered to present the efficiency of the voltage–frequency regulation. This inverter has proper performance in the energy system of the photovoltaic panel and energy storage system on the AC power network. The authors of [100] presented a new approach for dealing with harmonic distortion that is delivered from the main grid. In this research, a FOPID controller is simulated in the LCL voltage-based inverter circuit, and it could decrease the disruptive effects of harmonics.

## 3. Fractional-Order Technique and Renewable Energy Sources

In this section, several papers that follow different objects are reviewed. In these papers, FOPID and conventional controllers are utilized to improve steady-state performance. This section focuses on FO controllers used for renewable energy systems.

Table 2 is mentioned to point the readers to an overview of papers that studied fractional-order techniques in renewable energy systems. This table summarizes the application of fractional-order methods in renewable energy systems. The types of the used controller, function, algorithm, and type of distributed generation unit of each paper are available in this table. Table 2 shows that most authors have used the FOPID controller for renewable energy systems. The TID controller is another practical method. The metaheuristic algorithms are utilized in most papers for optimizing the controller parameters. On the other hand, the MPPT is the most iterated function due to the role of the power amount without distortion. The major objective of the papers is to minimize the nonlinearity and uncertainty of the system, which causes unstable situations in the steady-state condition.

In the papers associated with fractional-order methods and renewable energy sources, FOPID controller, photovoltaic panel, and wind turbine are the most utilized keywords. In other words, the FO method has been utilized to control the most common types of renewable energy resources, mainly WTs and PVs. Different types of controllers, methods, and optimizations are other types of information that can be found in Table 2. For example, all the papers develop their controllers based on the FOPID controller. Based on the method, the MPPT is the most popular method in photovoltaic panels, while the SMES is the most popular approach in wind turbines. Moreover, one of the vital parts of implementing the suggested control method is to select an appropriate optimization approach, and the reviewed papers demonstrate that metaheuristic algorithms have extensive stocks in the papers.

In the first reviewed paper on fractional-order application in the RESs, the authors proposed a specific algorithm to reach maximum power [101]. In that study, due to uncertain irradiation, the maximum power point tracking (MPPT) approach was implemented in the photovoltaic panels (PVs) by combining step size variables. According to Figure 3, for eliminating the disturbance factor of MPPT, the novel FOPID controller was attached by an incremental conductance algorithm. The results illustrate enhanced steady-state performance [101]. In [63], focusing on MPPT in PV panels, a new novel approach is presented by combining incremental conductance and FOPID. According to the obtained results, the loss of output voltage is reduced considerably. In [64], a study to reduce perturbation in the output voltage of PV panels was conducted. In this research, MPPT through the perturb and observe (PO) technique under uncertain atmospheric situations was investigated. Reshaped output power by adding FOPID, which is tuned by the grey wolf optimization (GWO) technique, causes an improved transient factor in the result of

the edited system. In [65], a novel high-energy tracking system from PV panels based on the perturb and observe technique was presented. In this paper, several events, such as inverter nonlinearity, the uncertainty of irradiation, and temperature, were adopted in the model. For compensating the PO technique, a FOPID controller is employed, and the optimal tuning of its parameters is obtained using the yin yang pair algorithm [102].

In the other paper, a geothermal power plant, dish Stirling, and high voltage DC system are connected to an uncertain environment. The specific scheme is presented for reducing the effects of harmonic distortion and having a robust system. The mixed FOPI-FOPID controller is replaced in the system and, using the sine cosine algorithm (SCA), the optimal adjustment of the parameters of the controller is conducted. The obtained results show improvements in the transient index such as overshoot and rise time [103]. Another application of the FOPID controller in the hybrid RES with combined energy storage was presented. The goal of the paper was to seek the objective frequency at which the system deviated from the equilibrium point, and after obtaining the result, the approach was validated with the mean square error method [104]. In [105], a fractional-order controller was presented to reduce tension and increase the robustness of the system. In this research, a novel controlling regime based on a fuzzy FOPID controller was proposed for hybrid renewable resources used for power generation and plentiful switching. The combination of the particle swarm optimization and chaotic map is utilized to extract the transient parameters of the controller [105].

**Table 2.** Summarization of applications of the fractional-order method in renewable energy systems.

Ref.	Type of Controller	Remark	Optimization/Analytical Method	Application
[94]	FOPID	Improving buck–boost efficiency with simulink	Analytical frequency domain design method	PV
[95]	FOPID	Tuning attached controller to DC-DC converter with simulink	Analytical frequency domain design method	PV
[97]	FOPID	Buck converter based on RLD	RLD	PV
[98]	FOPID	Asymmetrical cascaded H-bridge multi-level inverter with simulink	Analytical frequency domain design method	PV
[101]	FO controller	MPPT	Inc-Cond algorithm	PV
[102]	FOPID	MPPT	Yin yang pair algorithm	PV and WT
[103]	FOPI- FOPID	Deregulated AGC	Sine cosine algorithm	Geothermal plant
[104]	FOPID	Minimizing mean square error with simulink	Analytical frequency domain design method	RESs
[105]	Fuzzy FOPID	Chaos control	PSO	RESs
[106]	FO controller	Model control and space vector PWM	Analytical frequency domain design method	PV and WT
[107]	Fuzzy FOPID	Tuning WT inverter	TLBO	WT
[108]	FOPID	Pitch angle RBF neural network	Chaotic optimization	WT
[109]	FOPID	Generalized isodamping technique	Gain-scheduling algorithm	Solar system
[110]	FOPID	Yuning attached controller to DC-DC converter	PSO	HES
[111]	FOPI	Enhancing dynamic behavior	Metaheuristic algorithms	PV
[112]	FOPID-TID	load frequency control	Artificial ecosystem-based optimization	RESs
[113]	Fractional based TID	LFC and VIC	HGAPSO	RESs
[114]	FOPD-LFC	ITAE minimizing	SO algorithms	RESs
[115]	FOI-TD	Fitness-dependent optimizer	Hybrid sine cosine algorithm	RESs
[116]	FOPID	LFC and SEES controlling	Manta ray foraging optimization	RESs
[117]	FOPID	MPPT	Inc-Cond algorithm	PV
[118]	FOPID	MPPT	GWO	PV

In [106], research was presented for contrasting unstable situations and ensuring power quality in smart residential hybrid RESs. In this paper, a new FO controller implemented on an inverter's output break is controlled with the pulse-width modulation (PWM) method. A comparison of the proposed controller with the conventional controller shows a reduction in the tension of the output voltage [106]. Another paper about wind turbine (WT) output controllers was proposed in [107]. Fuzzy FOPID is replaced in the DC-AC converter section due to the uncertainty of wind speed and grid-connected wind power plants for reducing the effects of the dynamic situation. Rise time and fall time are improved by the tuning of controllers using the teaching-learning-based optimization (TLBO) algorithm overshoot [107]. In another paper, the pitch angle method was proposed for controlling the rotor speed and power production of the WT [108]. In this research, the FOPID controller is replaced with a radial basis function (RBF) neural network for improving system performance, and the chaotic optimization parameter of FOPID is tuned optimally. The result shows that by attaching the FOPID controller, the system's flexibility and robustness are increased in comparison to conventional controllers [108]. The authors of [109] designed a novel approach to deal with nonlinearity and increase the performance of the energy system. A FOPID controller is designed to cope with the destructive effects of the parameters. A numerical evaluation of the FOPID controller with a combined gain-scheduling algorithm and concentrated solar plant nonlinear model indicates its high performance in comparison with other controllers [109]. In another paper, the FOPID controller was presented due to the nonlinearity of the V-I characteristic of the PV panel [110]. In that paper, the boost DC-DC converter is utilized in the PV panel for regulating the output voltage. Moreover, particle swarm optimization is proposed for modifying the parameters of the FOPID controller [110].

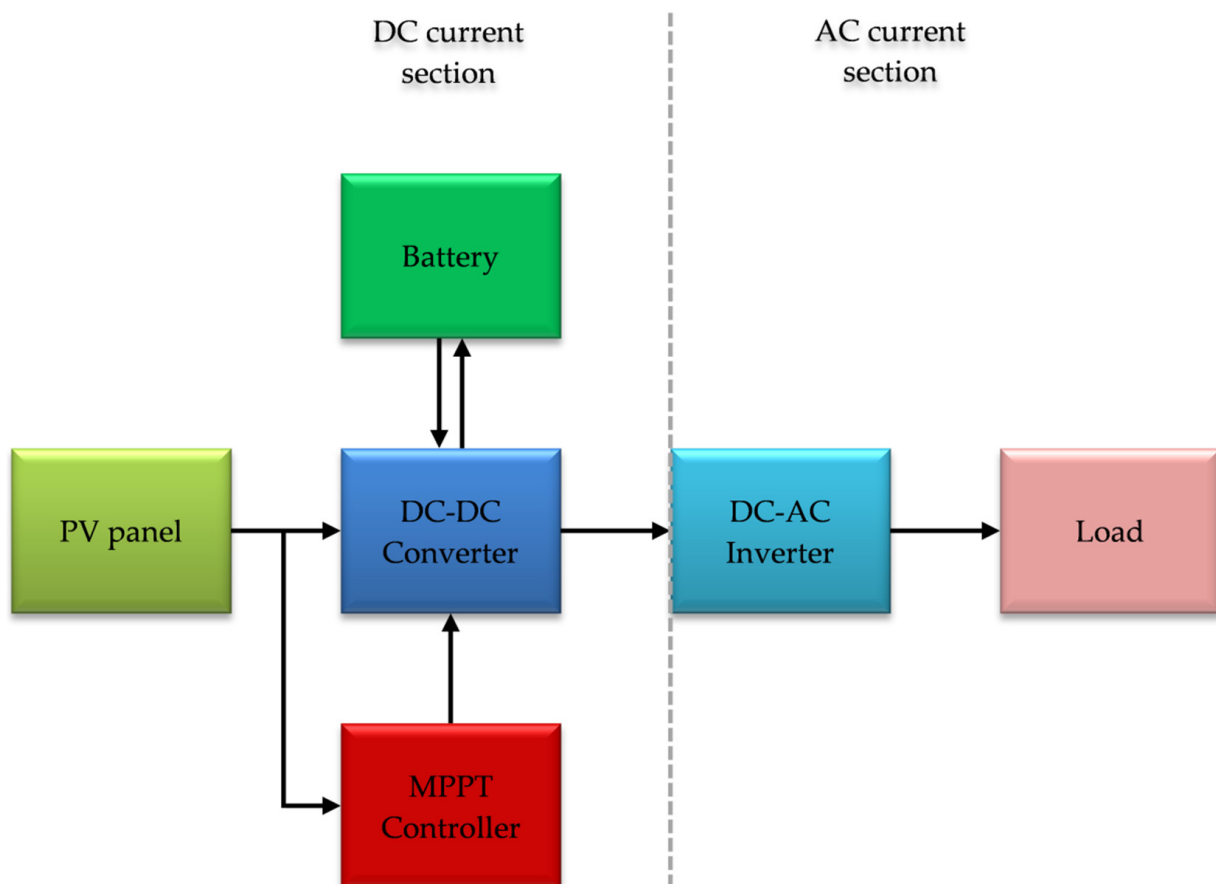

Figure 3. Diagram of the photovoltaic panel power generation.

Two controllers were presented for balancing the dynamic behavior of grid-connected PV panels in [111]. In this paper, metaheuristic algorithms such as cuckoo search (CS), GWO, the whale optimization algorithm (WOA), the mine blast algorithm (MBA), ABC, and the moth swarm algorithm (MSA) are used to optimize FOPI and PID controller parameters to reduce transient factors such as settling time and overshoot [111]. A study for mitigating the effects of renewable units and EVs present in the power system was proposed in [112]. In this paper, a controller consisting of both FOPID and TID controllers is presented to reduce frequency fluctuation and tie-line power deviation. The artificial ecosystem-based optimization (AEO) method for tuning parameters is used. Therefore, it can be said that the existence of different controllers with distinct performances increases the robustness and flexibility of the system [112]. A TID fractional-based controller was proposed for mitigating sensitive load and generation fluctuation. The power generation of RESs is penetrated to the power system due to the lowering of system inertia and unbalancing of the load and frequency. Therefore, load frequency control (LFC) and virtual inertia control (VIC) are proposed for compensating for RESs' penetration problems. Two TID controllers for each segment are placed using hybrid genetic PSO parameters of controllers, which use a case study combining RESs and conventional power production. In comparison to PSO and GA, the proposed algorithm is more effective and robust [113].

In [114], a new FOPD-LFC was proposed for covering the deficit of connecting RESs to the power grid due to power exchange and its violation. This paper aims to minimize the integral time absolute error (ITAE) with skill optimization. The proposed method was evaluated in two case studies, and the results were compared with the results of the jumping spider optimization algorithm and bonobo optimization. The proposed FO-based method has more reliability and stability than other algorithms [114]. A novel approach for controlling the nonlinearity of a system with RESs was proposed in [115]. The considered system has nonlinear loads and variable generation units. Therefore, the FOI-TD controller was designed for reducing the nonlinearity, and a hybrid sine cosine algorithm with a fitness-dependent optimizer was utilized to tune the controller's parameters. The result shows that the proposed algorithm outperforms other algorithms such as the fitness-dependent optimizer and PSO. Additionally, the designed controller reduces the overshoot and rise time [115]. The essential need for controlling the multi-area power system with renewable resources was investigated in [116]. In this paper, a new FOPID for controlling LFC and the superconducting magnetic energy storage system (SMES) is designed. The optimum points of the FOPID parameters are determined using the manta ray foraging optimization (MRFO) algorithm. Robustness and flexibility against nonlinearity is a prominent characteristic of the proposed controller [116].

#### 4. Fractional-Order Technique and Energy Storage Systems

In the last decade, energy storage systems have been widely utilized in MGs and EVs. Online and accurate modeling and estimation are essential to efficiently operate the storage systems and their upper energy system. The main purpose of studies on fractional-order control systems in ESSs is to improve the estimation rate of the SOC, state of energy (SOE), or other essential and uncertain parameters of the battery. In this section, the applications of FO techniques in the energy systems of different energy storage devices are presented and discussed based on various types of research.

Fractional-order method, lithium-ion battery, state of charge, Kalman filter, electrochemical impedance spectroscopy, and parameter identification are the most repeated keywords in the papers on FO methods and ESSs. In Table 3, the details of articles on FO techniques and ESSs are presented. In this table, different parameters of each paper such as ESS models, FO-based structures and technologies, and main objectives are given.

**Table 3.** The details of articles on the fractional-order controller and energy storage systems.

Ref.	ESS Model										FO-Based Structures and Techniques										Main Objectives									
	LIB	Supercapacitor	LMB	SMESS	Battery	EIS	GA	KF	SMT	PSO	HGAPSO	LSA	PTM	HGPO	MCA	ANA	KHO	ACA	ITLO	MGSO	SOC	Temperature	Voltage	SOP	Electrode aging	Control costs	Solid phase diffusion	SOH		
[119]	*					*	*	*													*									
[120]	*	*				*	*	*	*														*	*						
[121]	*					*	*	*		*												*		*						
[122]	*					*	*	*	*													*		*						
[123]	*		*			*	*	*	*													*		*		*				
[124]	*					*	*	*	*		*			*								*		*		*				
[125]	*					*	*	*	*												*		*		*					
[126]	*					*	*	*	*				*								*		*		*					
[127]	*	*				*	*	*	*												*		*		*					
[128]	*	*				*	*	*	*												*		*		*					
[34]	*	*				*	*	*	*												*		*		*					
[129]	*			*		*	*	*	*				*								*		*		*		*			
[130]	*			*		*	*	*	*					*							*		*		*		*			
[131]	*			*		*	*	*	*												*		*		*		*			*
[132]	*			*		*	*	*	*		*				*	*					*		*		*		*			
[133]	*			*		*	*	*	*												*		*		*		*			
[134]	*			*		*	*	*	*												*		*		*		*			
[135]	*			*		*	*	*	*												*		*		*		*			
[136]	*			*		*	*	*	*		*										*		*		*		*			
[137]	*			*		*	*	*	*												*		*		*		*			
[138]	*			*		*	*	*	*												*		*		*		*			
[22]	*			*		*	*	*	*												*		*		*		*			*
[139]	*			*		*	*	*	*												*		*		*		*			*
[140]	*			*		*	*	*	*		*										*		*		*		*			*
[141]	*			*	*	*	*	*	*												*		*		*		*			*
[142]	*			*		*	*	*	*												*		*		*		*			*
[143]	*	*		*		*	*	*	*					*						*		*		*		*				*
[144]	*			*		*	*	*	*							*					*		*		*		*			*
[145]	*			*		*	*	*	*		*										*		*		*		*			*
[146]	*			*		*	*	*	*		*										*		*		*		*			*
[147]	*			*		*	*	*	*												*		*		*		*			*
[148]	*	*		*		*	*	*	*												*		*		*		*			*
[149]	*			*	*	*	*	*	*												*		*		*		*			*
[150]	*			*		*	*	*	*												*		*		*		*			*
[151]	*			*		*	*	*	*											*		*		*		*		*		*

While the LIB has been considered as the energy storage device in most of the studies, such as [119,125,137], in papers [141,149,150], the entire structure of the energy storage system has been studied. The particular type of energy device has not been considered. In [120,148], both lithium-ion and supercapacitor ESSs have been considered. In these articles, the performance of different storage devices and the application of the FO model have been compared and evaluated. The supercapacitor ESS has been investigated in Refs. [34,127,143]. The authors of [123] proposed fractional-order techniques for the LMB. Refs. [129,151] are also about superconducting magnetic energy storage. According to the literature, LIBs are more efficient for practical operation, and therefore, the main focus of most research is on this type of ESS.



In [119], the fractional-order impedance model was investigated to overcome the drawbacks of electrochemical and electrical circuit models. The fractional parameters and electrochemical impedance spectroscopy (EIS) data were utilized in the defined impedance model. The GA was used to identify the order of the fractional elements after achieving the state space equations of the model by the GLD. The performance of the FO model was improved by utilizing the Kalman filter (KF) and short memory techniques. The numerical results presented that the proposed fractional-order model can improve the estimation rate of the SOC of the battery so that its estimation error is around 3%. The application of the FO model in the energy system of LIBs and ultra-capacitors was experimentally evaluated in [120]. The EIS and temperature-compensating fractional models of batteries and capacitors were presented, and the PSO algorithm was considered to identify the online parameters. Based on the numerical results, the presented FO model can obtain a more accurate value of stochastic parameters with less than 4% error. The authors of [121] suggested FO estimation and control algorithms for the electrical storage system. The combination of the particle swarm optimization method and the GA was used to identify the parameters of the fractional model. Its structure was defined by evaluating a series of pulse tests at various levels of the battery's charge. Moreover, online charge estimation was used to increase the convergence speed and obtain more accurate results. In the proposed FO model, the behavior of the battery over different current and voltage rates was also researched. Numerical results, achieved under various load profiles, presented that the proposed FO-based estimation method has more accurate results than KF-based methods by up to 1.2%.

In [122], a fractional-order model was presented to estimate the SOC of batteries, especially lithium-ion types. In the proposed model, the charging and discharging characteristics were described using a circuit model and then the model parameters were identified by the PSO algorithm. The proposed order-dependent model was evaluated utilizing real-time experimental data. The results showed the feasibility and validity of the FO model to observe the more accurate rate of battery charge. The authors of [123] investigated the fractional order model and EIS for liquid metal batteries (LMBs) as one of the practical ESSs in the last few years. The general electrochemical reaction process was considered to define the fractional-order circuit model. Moreover, the impedance spectra were analyzed to extract the parameters of the battery. The results, achieved from simulations and experiments, presented good performance and stability of the FO model for the battery management system. In [124], the relationship between the FO and electrode aging was investigated. The utilized battery for studying was the lithium-ion type. The system of the FO model was identified using the transient discharge dataset of the fully charged situation of the battery. The numerical results, which were achieved by applying the model to the actual data, presented that the FO can properly evaluate the degradation level of electrodes so that there is a steady relationship between the proposed model and the charging/discharging cycle of the battery. On the other hand, the battery life is terminated when the FO model tends to be stable.

The short- and long-time evaluation of the dynamic of ESSs was presented in [125] considering frequency parameters. In this study, the FO model was defined using modified electrochemical impedance spectroscopy. The modified version of the impedance model appropriately selected the internal dynamics in both short and long periods. Moreover, it could capture the low-frequency dynamics of the battery. Numerical results showed the high performance and proper adaptability of the proposed FO model to evaluate the dynamics of the battery in different operating conditions so that the maximum error was below 0.86%. The authors of [126] studied the application of the FO model to show the effect of thermal and electrolyte variations on LIBs. The polarization in electrolytes was utilized to modify the proposed FO model. In the proposed model, the heat absorption/generation of the battery cell was also described using the particle thermal model. The numerical evaluations presented high stability of the modified fractional-order model in various ranges of current, voltage, and temperature. In [127], the FO model was presented to

explain the frequency-dependent behavior of electrical storage devices in energy systems. In this research, both the transient and steady modes of the storage system were considered to evaluate the electrical system of the fractional-order capacitance and inductance. The fractional-order coils and supercapacitors were utilized to verify the proposed FO model. The results expressed the proper performance of the proposed model to present the level of stored energy in commercial electrical storage devices. An FO model, which was modified using the Kalman filter, was presented in [128] to estimate the SOC of batteries. The LIBs were studied in that paper. In that paper, the FO model describes the physical behavior of the battery. The GA was utilized to identify the parameters of the model. The KF was also used to modify the proposed model in order to increase the stability of the estimation and better track the noise variance. The experimental data presented that the proposed FO-based model performs better and more accurately than the traditional KF-based models.

The authors of [34] developed an FO control method for the supercapacitor type of ESSs. In the defined model, the inherent physical characteristics of the storage system and the transient responses were considered and analyzed to obtain global control stability. Moreover, the sliding-mode control was also applied to the FO model to improve the robustness of the closed-loop system. The proposed control method was evaluated under different energy situations and the presence of various energy sources in the distribution system. The results presented more stability and feasibility of the FO-based model than the other control methods. Ref. [129] suggested a nonlinear control method utilizing FO control for analyzing the ESS. The ESS was a combination of battery and superconducting magnetic storage. The proposed FO control model has the ability to compensate for the nonlinearities and model the uncertainties through online estimation. Moreover, it improves the control performance of the ESS while only the voltage and current of the storage are measured instead of accurate modeling of the system. The numerical evaluation of the proposed method showed that the FO control method improves the storage system's performance and reduces the control costs of the system more than other control methods such as sliding-mode control and feedback linearization control. An FO model was proposed in [130] to estimate the electrochemistry dynamics of lithium-ion batteries. The GA was used to identify the parameters of the proposed model. Moreover, the KF was utilized to modify the FO control method in estimating the SOC. The proposed control method was simulated and compared with the Thevenin model. The numerical results showed that the FO control method is more accurate and robust than the other one. The authors of [131] presented a physics-based fractional-order model for simply analyzing the cycle of energy storage devices. This study focused on lithium-ion batteries. The dynamics of medium-high frequency were considered to define the full-cycle model. For this reason, it can be applied to the full-cycle operation of the battery. The proposed physical fractional-order model was evaluated using different loads. The obtained results presented that the defined model has suitable performance for online applications, so it has high stability in extracting the solid phase diffusion. In [132], a new technique based on the FO method was introduced to estimate the SOC of the battery. The proposed model was based on the open circuit voltage. The PSO method was utilized to select the parameters of the FO-equivalent model. To increase the accuracy and convergence rate of the estimation method, a particle filter, which was modified by an adaptive noise updating algorithm, was added to the proposed FO model. The numerical results, achieved by applying the proposed method to static and dynamic conditions, showed the appropriate convergence rate and high stability of the proposed charge estimation method. The state of power of LIBs was investigated in [133]. It is worth mentioning that in the evaluation of the SOP, it is considered that the battery is working with the maximum possible power rate. In this paper, the fractional-order model was suggested to estimate the power level of the battery. In this model, the voltage, current, and SOC of the battery were modeled by FO calculus. The numerical results presented that the proposed estimation model with approximately 1.34% error has high accuracy for calculating the SOP of the battery in different operating conditions. The authors of [134] proposed another FO-based model for estimating the SOC

of lithium-ion storage devices. In the presented method, the FO model was modified using a Kalman filter and EIS in order to reduce the error rate of the electrical equivalent circuit and increase the stability of the model. The parameter of the model was identified by the quantum particle swarm optimization algorithm. Moreover, the Grünwald–Letnikov fractional derivative and time-varying measurement error covariance were added to the model to promote the convergence speed of the estimation method. The simulation results showed a better performance of the FO model compared to other estimation methods to estimate the state of the charge of the battery.

In [135], to find the correct charge level of LIBs, a new fractional-order model was presented. The KF was utilized in this technique to increase the adaptive ability of the estimation method in a complex operating state. The Sigmoid function was added to the model to find the unknown parameters. Moreover, the augmented vector technique was utilized to better describe the nonlinear function of the storage device. Simulation and experimental data presented the high estimation stability of the FO model to estimate the SOC of the battery. Moreover, it has adequate ability in complex environments. A multi-parameter FO model, defined using 25 parameters, was presented for analyzing the battery in [136]. The considered battery type was lithium-ion. The combination of particle swarm optimization and the genetic algorithm was utilized to identify the parameters. Moreover, the proposed multi-domain model was defined using two domains including frequency and time. The frequency domain is based on EIS, and the time domain is based on the terminal voltage of the battery. The proposed FO model is robust and reliable for identifying and analyzing the storage device; this claim was pondered and proved by the numerical evaluations in the MATLAB environment. In [137], a new method for estimating the state of charge of LIBs was proposed. The suggested estimation method was based on the FO and KF. The parameters of the model were identified using the adaptive genetic algorithm. During the test condition, the root mean square error of the estimation method was less than 1%. Moreover, the FO model had more stability and robustness than other KF-based techniques in estimating the SOC of the battery. The authors of [138] proposed a hybrid method for estimating the state of charge and analyzing the ESS. This model combines the FO-equivalent model and the FO adaptive dual Kalman filter. The first part of the model is utilized to achieve the external electrical characteristics of the battery, while the second part of the proposed model estimates the battery's charge level. The evaluation of the proposed method in different experimental conditions presented more convergence, lower error, and higher stability of the proposed FO technique than other estimation techniques. In [22], an FO model was established to accurately estimate the state of charge and state of health of ESSs. In this second-order model, the adaptive genetic algorithm is utilized to identify the model parameters. Then, the multi-innovations unscented Kalman filter is applied to estimate the charge and health level of the battery. The performance of the estimation technique was pondered by evaluating the experimental results achieved from different cycles and operating conditions. By utilizing the proposed method, the estimation error of both SOC and SOH was lower than other methods, so its root mean square error was less than 1.2% and 0.007% in predicting the charge and health level of the battery, respectively. Thus, the proposed FO model had adequate accuracy. Another fractional-order model for estimating the SOC of the battery was introduced in [139]. The LIBs were studied in this paper. In the proposed FO model, various temperatures and operating conditions were modeled. The model parameters were optimized by using a Krill Herd optimizer in order to obtain an appropriate model. The validation of the proposed technique was evaluated using different operating conditions, temperatures, and SOC ranges. The numerical results, which were achieved from various tests such as hybrid pulse power characteristic and dynamic stress tests, presented high accuracy and reliability of the method in different situations. This method also had lower errors than other estimation methods. The authors of [140] proposed a multi-scale algorithm to estimate the accurate SOC of the batteries by focusing on lithium-ion technology. The estimation algorithm is based on the FO model. It was modified using the KF and variable forgetting factor recursive least squares. Indeed,

the KF was used to enhance the estimation accuracy, and the variable forgetting factor algorithm was utilized to predict the internal resistance and capacity of the battery. The ant colony algorithm was utilized to extract the model parameters. The proposed model experimented with a fast variation of the SOC and a slow variation of the internal resistance of the battery. The results proved the strong power of the model in analyzing the energy storage device. The estimation error of the method was approximately 0.52%.

A new dual fractional-order model, which was extended using the KF and resistance–capacitor approximation method, was presented in [141] for simultaneous estimation of the SOC and fractional parameters of the battery. In this technique, the Grünwald–Letnikov definition was utilized to represent the discrete state space. Moreover, both frequency and time domains were investigated in this paper. The method was validated considering different operation levels. According to the simulation results, the proposed FO model with less than 0.28% root mean square error has high accuracy in SOC estimation, and therefore, it can be utilized in real operating conditions. In [142], a fractional-order-equivalent circuit model was suggested to analyze the battery energy system. To synchronously identify the parameters of the model and its order values, the PSO algorithm was utilized. In this study, the capability of the model was evaluated in various FO values, and therefore, the best values were selected. According to the numerical results, the proposed model has suitable performance for identifying the battery data. A robust fractional-order control method was proposed in [143] for controlling the parameters of the supercapacitor ESS. In the first step of the proposed technique, different parameters of the storage system such as uncertainties, disturbances, nonlinearities, and dynamics were predicted by the high-gain perturbation observer. Secondly, the FO controller estimated the online compensation rate. During the observation and control cycle, the interactive teaching and learning optimizer was utilized to achieve the gains of the observer and controller. The numerical results, which were achieved from different cases and control strategies, presented the high effectiveness of the proposed method for practical applications. In [144], an FO model was proposed to evaluate multiple groups of lithium-ion batteries with various states of health. Electrochemical impedance spectroscopy was utilized to extract the structure and parameters of the equivalent circuit model. Then, the P-type iterative learning algorithm was applied to optimize the selected parameters. To increase the reliability of the structure, the model was modified by pretest noise, correlative information criterion, and multiple correlations of parameters. The evaluation of the model considering different batteries with various states of health presented its high quality for estimating the health level and analyzing the situation of the energy storage devices. A fractional-order model was presented to evaluate the LIBs in [145]. The presented model was modified using the Randles model, equivalent circuit model, and free non-integer differentiation orders. Moreover, multi-objective particle swarm optimization was utilized to identify the parameters of the FO model. The efficiency and stability of the suggested method were proved by evaluating the storage system against the traditional resistance capacitor circuit model. The authors of [146] presented an FO model to estimate the charge situation of the battery in a storage management system. The LIB was the considered type of energy device for estimating. In the proposed method, the time and frequency domains were studied using the recursive least squares algorithm and recorded impedance spectroscopy, respectively. Moreover, the modified Kalman filter was used in the proposed method in order to estimate the SOC of the battery. According to the numerical evaluations, the proposed FO technique is more efficient and accurate than other methods such as the classical equivalent electric circuit.

In [147], an FO model was presented to implement the electrochemical impedance spectroscopy in the ESS. The main focus of this study was on LIBs. In the proposed method, the capacitive resistance circuit was utilized to extract the model parameters in both offline and online modes. The numerical evaluations presented high efficiency and stability of the proposed method for closely indicating the SOC, discharge rate, and aging degree of the storage device. A new FO-based technique was investigated in [148] to evaluate the remaining discharge time of the ESS. The LIBs and supercapacitors were studied in this

paper. The combination of chaos theory and the PSO algorithm was utilized to extract the parameters of the model. Moreover, the Markov load trajectory prediction was applied to the method for increasing its accuracy. The reliability and robustness of the FO technique were proved by evaluating the method in a real operating environment. In [149], an FO model was presented to simultaneously evaluate the ESS and the demand response program. The method was investigated in a power network in the presence of thermal power plants, biogas units, wind turbines, and photovoltaic panels. Control of the frequency parameters of the system was the main goal of introducing this FO technique. The quasi-oppositional Harris hawk algorithm was utilized to optimize the considered coefficients. The simulation of the method in real-time conditions showed its appropriate feasibility to control the indices of the system. The authors of [150] presented another FO model for controlling the ESS in a distribution system in the presence of various energy sources such as wind turbines and PVs. In this study, the main goal of the controlling method was to stabilize the bus voltage of the system under different operation conditions. The numerical results presented that the proposed technique has more stability and reliability than other controllers such as sliding-mode control and PI control. The author of [151] proposed a control method based on FO controllers to evaluate and control the ESS in the power network. The considered indices of the system were optimized using metaheuristic algorithms. To achieve reliable and realistic results, the proposed model was modified using the governor dead band, generation rate constraint, and communication time delay. Moreover, the sensitivity analysis was utilized to verify the performance of the method. The numerical results presented that the suggested technique has more accuracy than common controlling methods so that the mean controlling error of the fractional-order method is considerably lower than PID and PI controllers.

The utilized electrical circuit for presenting the ESS is different in various papers. In Figure 4, the considered electrical circuits and their description are presented. In the presented circuits, different parameters such as dynamic characteristics, voltages, currents, temperatures, and storage capacities are considered and modeled using electronic devices such as resistances and capacitors and controlling blocks such as integrals and derivatives.

In the electric circuits of Figure 4,  $R_0$  is the ohmic resistance.  $R_1$  and  $R_2$  show resistors that are modeled in parallel with constant phase elements. The CPE is considered to describe the charge transfer between the electrolyte interface and the double layer of the storage system. The impedance of CPE ( $Z_{CPE}$ ) can be mathematically calculated by using Equation (12).

$$Z_{CPE}(S) = \frac{1}{C_{CPE}S^\alpha} \quad (12)$$

In Equation (12),  $C_{CPE}$  is an index similar to a capacitor, and  $S$  is the Laplace operator. The parameter  $\alpha$  is the fractional order for describing the dispersion effect. It is a positive number between 0 and 1. It should be considered that the CPE behaves like the ideal capacitor when  $\alpha$  is 1, and it behaves like the resistor when  $\alpha$  is 0. The Warburg element ( $W$ ), which represents the diffusion process in solid phases of the low-frequency band of the storage device, is like a constant phase element.

One of the steps for applying the FO model for controlling, estimating, or evaluating the ESS is the identification of the required parameters of the proposed model. Optimization algorithms and electrochemical tests are the most used methods for identifying the model parameters in different research studies. In Table 4, the utilized methods in various papers for selecting the required parameters of the FO models of ESSs are presented. As can be seen in this table, electrochemical tests are the most utilized method for identifying the parameters. In contrast, the PSO method is the most applied intelligent algorithm to extract the model parameters.



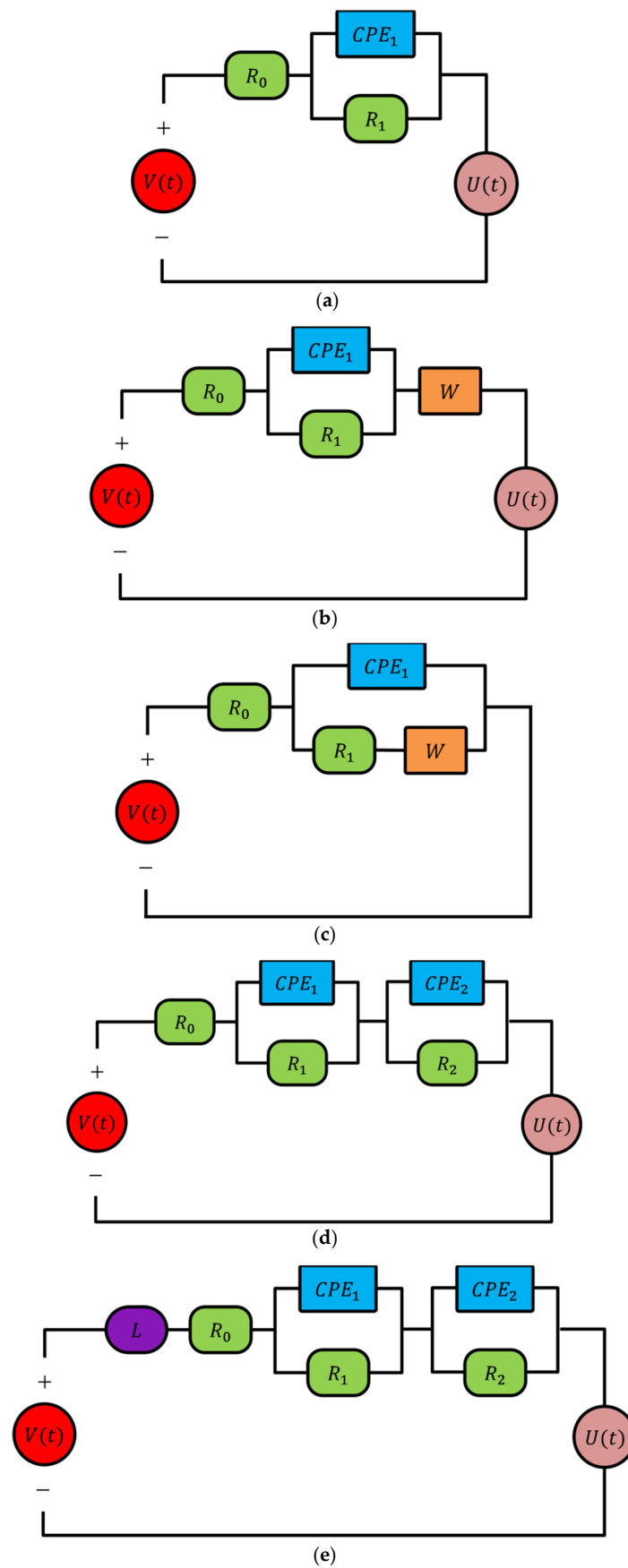
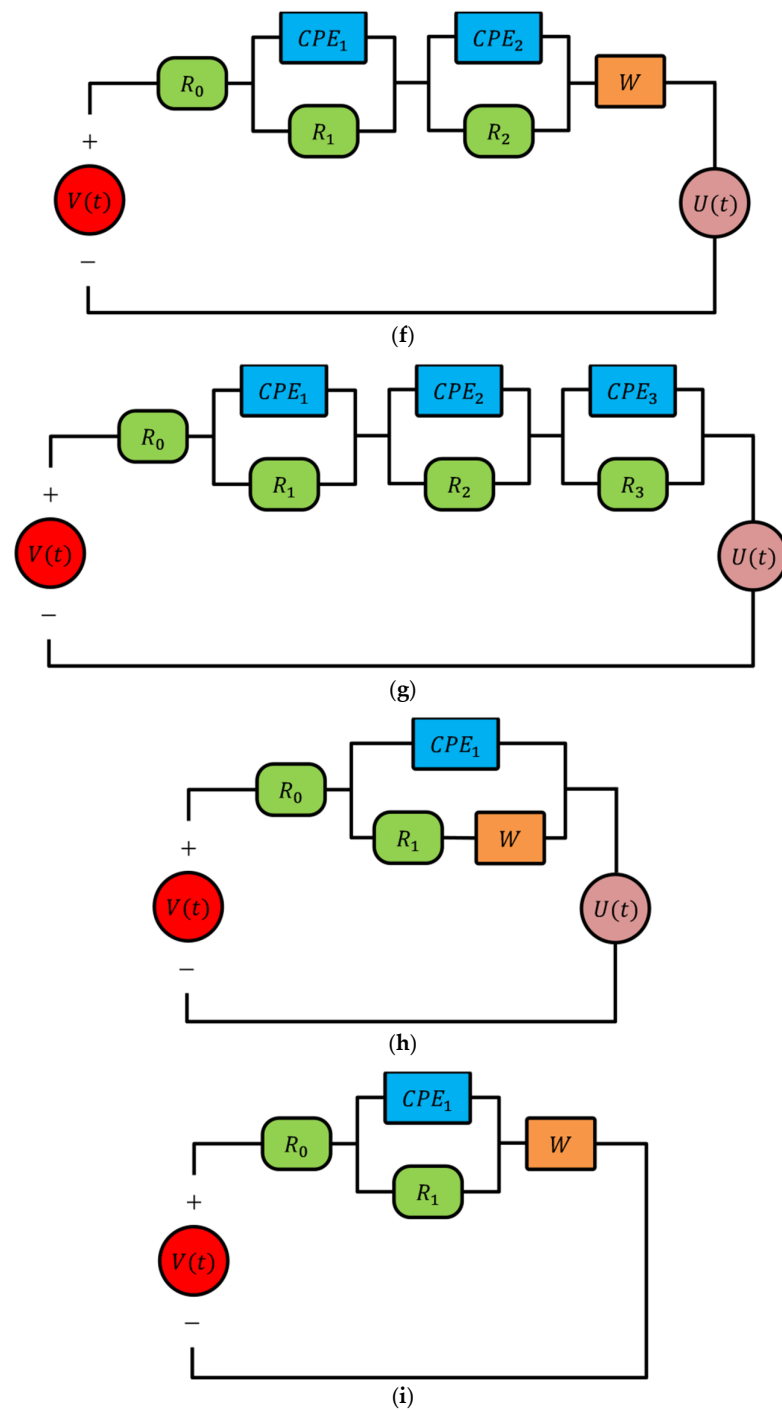

Figure 4. Cont.





**Figure 4.** The equivalent electrical circuits for energy storage systems. (a) Lithium-ion battery [119,122,124,132,134,135,138]; (b) Lithium-ion battery [119,120,144]; (c) Supercapacitor storage [120]; (d) Lithium-ion battery [22,121,128,130,137,140,142,146,148]; (e) Liquid metal battery [123]; (f) Lithium-ion battery [133,136,139]; (g) Lithium-ion battery [141]; (h) Lithium-ion battery [145]; (i) Supercapacitor storage [148].

One of the techniques for the practical implementation of the FO model in storage systems is EIS. It is a powerful method for separating the electrochemical reactions at electrode surfaces [152]. The measured electrochemical impedance spectra are usually divided into three parts based on the frequency. High frequency, middle frequency, and low frequency are the divided parts of the impedance spectra [153]. In Figure 5, the sample electrochemical impedance spectra of the two most utilized types of ESSs, lithium-ion

batteries and liquid metal batteries, are demonstrated [119–123]. In the FO method, the impedance spectra are utilized to model the dynamics between the electrodes of the storage system in different operating situations.

**Table 4.** The identifier of model parameters of the fractional-order technique in energy storage systems.

Identification Method	Refs.
Hybrid of genetic algorithm and particle swarm optimization	[119,136]
Global optimization	[22,120]
Hybrid pulse tests	[121]
Particle swarm optimization	[122,133,134,142,145,148]
Electrochemical impedance spectroscopy	[123,125,141,144,146,147]
Least squares method	[124]
Pseudo-two-dimensional electrochemical method	[126]
Specific current condition test	[128]
Genetic algorithm	[130,137]
Decoupling the dynamics in frequency and spatial domain	[131]
Dynamic stress test	[132,139]
Augmented vector method	[135]
Forgetting factor recursive least squares method	[138]
Ant colony algorithm	[140]

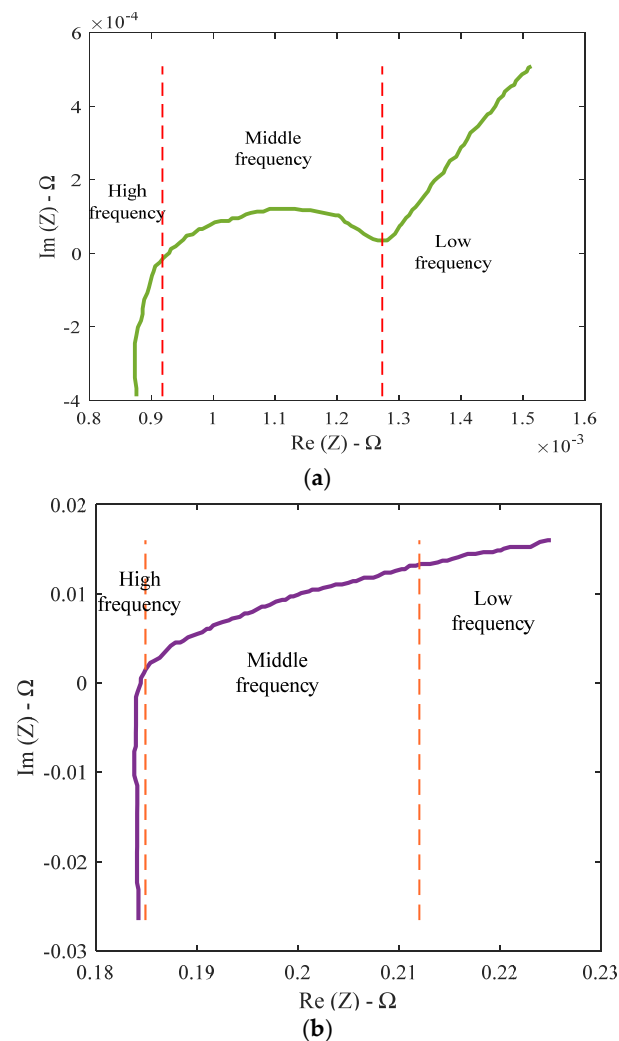

**Figure 5.** The sample electrochemical impedance spectra of energy storage systems. (a) Lithium-ion batteries; (b) Liquid metal batteries.

The estimation of the battery's parameters such as the SOC during real operation of the power network and also EV operation is a major and complex challenge due to the nonlinear properties of the storage systems. The FO technique is useful for analyzing and achieving the proper parameters. The FO models have unique advantages and more accuracy compared with the conventional electrochemical models and equivalent circuit models [120]. The fractional-order technique has been utilized to estimate the state of charge of ESSs used in EVs and MGs. In [122], the estimation power of the FO model was compared with the real-time data and the extended Kalman filter method. Figure 6 shows the SOC of the battery considering different estimation methods and the actual data. According to the results, the maximum estimation error of the FO method is 1.50%, while the maximum estimation error of the extended Kalman filter is 5.11%. Therefore, the fractional-order model reduces the estimation error by up to 71% [122].

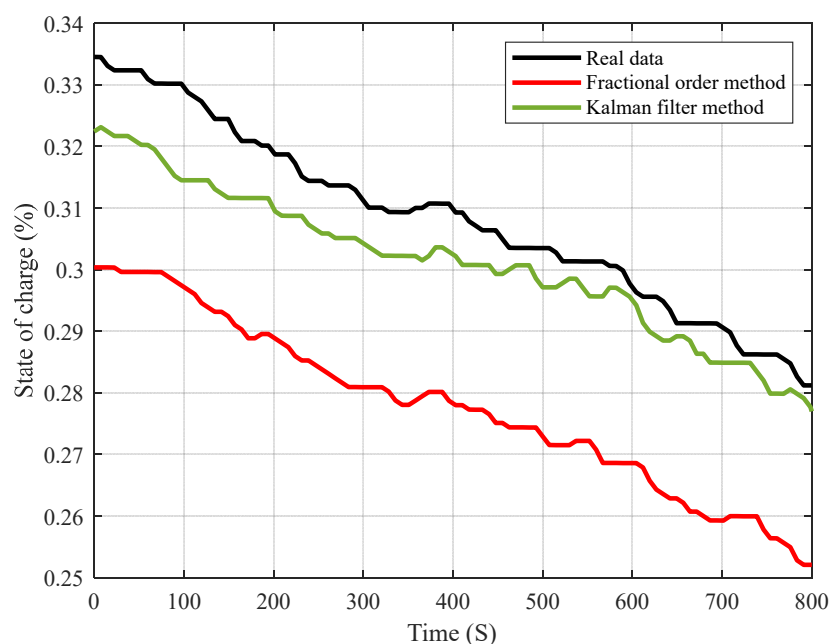

**Figure 6.** The state of charge of the energy storage system considering different methods.

In another study, experimental evaluations proved that the FO method has high stability and proper adaptability so that it appropriately identifies the electrochemical dynamics of the ESS with a 0.86% maximum relative absolute error [125].

The estimation error of the voltage of the ESS during the operation considering two methods is shown in Figure 7. As can be seen in this figure, the voltage estimation error of the FO model is lower than that of the integer-order model. The error rate of the fractional-order method is about 0.13%, while the estimation voltage of the integer-order method has an error of approximately 0.16%. Therefore, the fractional-order technique has more accuracy in estimating the voltage of the energy storage system [128].

The FO method also has more effectiveness and stability in controlling the nonlinear and uncertain parameters of the ESS. According to the numerical evaluations, the error rate of the fractional-order-based technique is 8.79%. At the same time, the feedback linearization control, the proportional integral derivative control, and the sliding-mode control have 31.86%, 14.54%, and 11.31% error rates, respectively. Thus, the FO method has more stability and efficiency than other methods [129].

In another study, the performance of the fractional-order method in estimating the SOC of the ESS was compared with the KF [137]. Experimental results presented that the average error of the Kalman filter is 0.73%, while the average error of the fractional-order model is 0.55%. Therefore, the estimated SOC by the fractional-order method has approximately 25% more accuracy than the result obtained by using the KF [137].

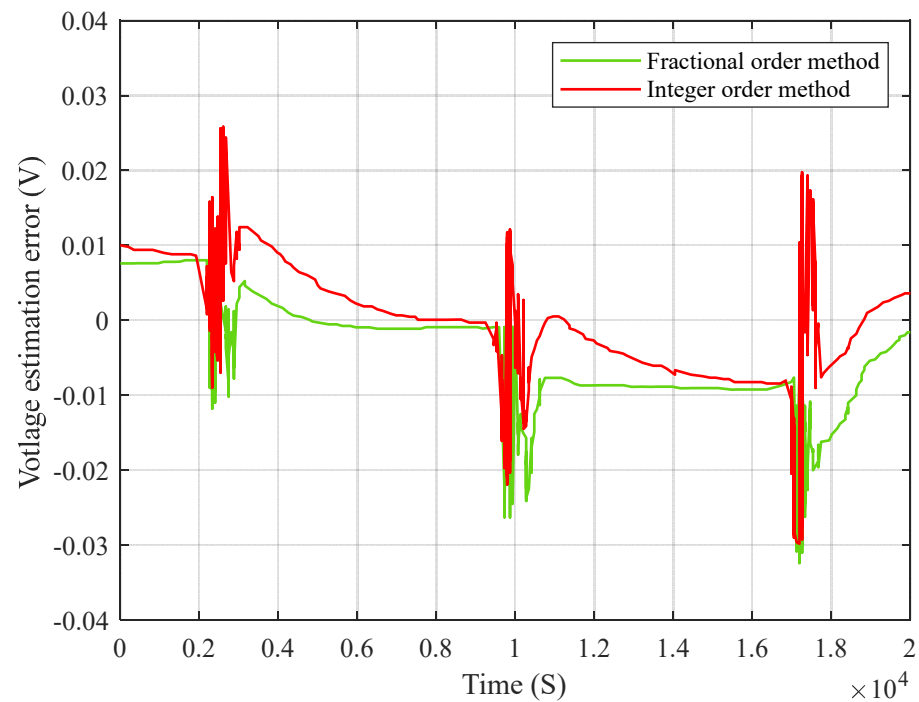

**Figure 7.** The voltage estimation error of energy storage system considering different methods.

The fractional-order methods have more stability than other methods in controlling systems. Table 5 presents the details of the energy system after applying a fault considering FOPID, TID, and PID controllers. In this table, the settling time (ST), the peak time (PT), the magnitude of the peak (MP), the integral of squared error (ISE), and the integral of time-multiplied absolute error (ITMAE) of the energy system after applying a fault to the system are given. As can be shown in this table, the FOPID method is about 31% faster than PID and TID controllers in controlling any disturbance in the system. Moreover, it has 33–50% and 45–57% lower ISE and ITMAE than classical controllers, respectively. The numerical results show that the fractional-order controller has more stability and lower error than other ones [151].

**Table 5.** The details of different controllers.

Control Strategy	Control Parameters				
	ST (s)	PT (s)	MP (Pu)	ISE	ITMAE
PID	25.85	1.76	0.07	0.04	7.67
TID	25.23	1.74	0.06	0.03	6.04
FOPID	17.81	1.74	0.04	0.02	3.31

## 5. Future Perspectives

Fractional-order systems have attracted the attention of many researchers in recent years due to their wide application in various branches of engineering, such as renewable energy systems, energy storage systems, secure communications, nonlinear control, information processing, biological systems, etc. The most important goals and challenges in applications of fractional-order systems that require more extensive investigation are as follows:

1. Utilizing the combination of fractional-order techniques and intelligent estimation methods in order to model uncertain and stochastic dynamics of RESs and ESSs in different operational conditions.

2. Considering fractional-order methods and training algorithms to design self-regulated systems for RESs and ESSs in order to respond to various practical faults in the distribution systems appropriately.

3. Studying fractional-order controllers of energy systems of RESs and ESSs considering the delay of measurement devices, which causes a delay in the output controlling signal, and investigating the effect of this delay on the practical performance of RESs and ESSs.

4. Studying the effects of estimations errors, the uncertainty of the system, and external perturbations on the modeling, controlling, and stability of fractional-order methods in the energy systems of RESs and ESSs.

## 6. Conclusions

A fractional-order system is a dynamical system that is modeled by fractional differential equations and a non-integer derivative. In other words, the fractional-order technique utilizes an impedance model based on the FO theory to identify, estimate, and control the energy system. In this paper, a comprehensive review of the energy system of renewable energy units and energy storage devices was presented. The mathematical fundamentals of the FO method were mentioned, and the various studies were categorized based on different parameters. The FO formulations were presented, and its most utilized definitions were formulated. Additionally, its applications in inverters and converters were investigated. Different studies and numerical evaluations present appropriate efficiency and stability of the FO techniques for estimating, controlling, and improving the performance of energy systems in various operational conditions. According to the different studies, the FO method has appropriate accuracy for estimating uncertain parameters. Its estimation error is considerably lower than that of other classical methods in practical systems. The fractional-order technique has more stability and lower steady-state error than other methods such as integer-order and electrochemical models, so the estimation and control errors of the FO technique are considerably lower than those of other ones. Moreover, it is also faster than other techniques. Therefore, it has appropriate performance in online, real-time, and complex operating conditions. Although fractional-order methods have attracted the attention of many researchers in recent years, modeling the uncertainties and stochastic dynamics of RESs and ESSs, designing self-regulated systems, considering the delay of measurement devices, and evaluating the effects of delays and estimation errors on the output controlling signals of FO-based controllers are the most important challenges in applications of FO systems in RESs and ESSs, which can be considered for more investigations in future projects about fractional-order methods.

**Author Contributions:** Conceptualization, M.A. and H.A.; methodology, M.A.; software, M.A.; validation, M.A. and A.O.; formal analysis, A.O.; investigation, B.M.-I.; resources, M.A. and H.A.; data curation, M.A.; writing—original draft preparation, M.A. and H.A.; writing—review and editing, A.O., B.M.-I. and R.T.; visualization, R.T.; supervision, B.M.-I.; project administration, M.A.; funding acquisition, B.M.-I. All authors have read and agreed to the published version of the manuscript.

**Funding:** This research is supported by the research grant of the University of Tabriz (number S-10).

**Data Availability Statement:** Not applicable.

**Conflicts of Interest:** The authors declare no conflict of interest.

## Nomenclatures and Abbreviations (In Alphabetical Order)

ABC	Artificial bee colony
ACA	Ant colony algorithm
AEO	Artificial ecosystem-based optimization
ANA	Adaptive noise algorithm
ANN	Artificial neural network
BEL	Brain emotional learning
CD	Caputo definition

---

CPE	Constant phase element
CS	Cuckoo search
EIS	Electrochemical impedance spectroscopy
ESS	Energy storage system
EV	Electric vehicle
FO	Fractional order
FOPID	Fractional-order proportional integral derivative
GA	Genetic algorithm
GLD	Grünwald–Letnikov definition
GWO	Grey wolf optimization
HGAPSO	Hybrid of GA and PSO
HGPO	High-gain perturbation observer
ISE	Integral of squared error
ITAE	Integral time absolute error
ITLO	Interactive teaching–learning optimization
ITMAE	Integral of time multiplied absolute error
KF	Kalman filter
KHO	Krill herd optimization
LFC	Load frequency control
LIB	Lithium-ion battery
LMB	Liquid metal battery
LSA	Least square algorithm
MBA	Mine blast algorithm
MCA	Monte Carlo algorithm
MG	Microgrid
MGSO	Modified group search optimization
MP	Magnitude of the peak
MPC	Model predictive control
MPPT	Maximum power point tracking
MRFO	Manta ray foraging optimization
MSA	Moth swarm algorithm
OA	Optimization algorithm
OSD	Oldham and Spanier definition
PD	Proportional derivative
PI	Proportional integral
PID	Proportional integral derivative
PO	Perturb and observe technique
PSO	Particle swarm optimization
PT	peak time
PTM	Particle thermal method
PV	Photovoltaic panel
PWM	Pulse-width modulation
RBF	Radial basis function
RES	Renewable energy source
RLD	Riemann–Liouville definition
SCA	Sine cosine algorithm
SMESS	Superconducting magnetic energy storage system
SMT	Short memory technique
ST	Settling time
SG	Smart grid
SOC	State of charge
SOH	State of health
SOP	State of power
TID	Tilted integral derivative
TLBO	Teaching–learning-based optimization
VIC	Virtual inertia control
WOA	Whale optimization algorithm
WT	Wind turbine



## References

1. Mohamed, M.A. A relaxed consensus plus innovation based effective negotiation approach for energy cooperation between smart grid and microgrid. *Energy* **2022**, *252*, 123996. [[CrossRef](#)]
2. Alilou, M.; Tousi, B.; Shayeghi, H. Multi-objective energy management of smart homes considering uncertainty in wind power forecasting. *Electr. Eng.* **2021**, *103*, 1367–1383. [[CrossRef](#)]
3. Nazari-Heris, M.; Abapour, M.; Mohammadi-Ivatloo, B. An Updated Review and Outlook on Electric Vehicle Aggregators in Electric Energy Networks. *Sustainability* **2022**, *14*, 5747. [[CrossRef](#)]
4. Rezaei, H.; Abdollahi, S.E.; Abdollahi, S.; Filizadeh, S. Energy management strategies of battery-ultracapacitor hybrid storage systems for electric vehicles: Review, challenges, and future trends. *J. Energy Storage* **2022**, *53*, 105045. [[CrossRef](#)]
5. Aliasghari, P.; Mohammadi-Ivatloo, B.; Alipour, M.; Abapour, M.; Zare, K. Optimal scheduling of plug-in electric vehicles and renewable micro-grid in energy and reserve markets considering demand response program. *J. Clean. Prod.* **2018**, *186*, 293–303. [[CrossRef](#)]
6. Erdinç, F.G.; Çiçek, A.; Erdinç, O.; Yumurtacı, R.; Oskouei, M.Z.; Mohammadi-Ivatloo, B. Decision-making framework for power system with RES including responsive demand, ESSs, EV aggregator and dynamic line rating as multiple flexibility resources. *Electr. Power Syst. Res.* **2022**, *204*, 107702. [[CrossRef](#)]
7. Alilou, M.; Gharehpetian, G.B.; Ahmadihangar, R.; Rosin, A.; Anvari-Moghaddam, A. Day-Ahead Scheduling of Electric Vehicles and Electrical Storage Systems in Smart Homes Using a Novel Decision Vector and AHP Method. *Sustainability* **2022**, *14*, 11773. [[CrossRef](#)]
8. Zhang, G.; Ge, Y.; Ye, Z.; Al-Bahrani, M. Multi-objective planning of energy hub on economic aspects and resources with heat and power sources, energizable, electric vehicle and hydrogen storage system due to uncertainties and demand response. *J. Energy Storage* **2023**, *57*, 106160. [[CrossRef](#)]
9. Sun, H.; Zhang, Y.; Baleanu, D.; Chen, W.; Chen, Y. A new collection of real world applications of fractional calculus in science and engineering. *Commun. Nonlinear Sci. Numer. Simul.* **2018**, *64*, 213–231. [[CrossRef](#)]
10. Shah, P.; Agashe, S. Review of fractional PID controller. *Mechatronics* **2016**, *38*, 29–41. [[CrossRef](#)]
11. Hidalgo-Reyes, J.I.; Gómez-Aguilar, J.F.; Escobar-Jiménez, R.F.; Alvarado-Martínez, V.M.; López-López, M.G. Classical and fractional-order modeling of equivalent electrical circuits for supercapacitors and batteries, energy management strategies for hybrid systems and methods for the state of charge estimation: A state of the art review. *Microelectron. J.* **2019**, *85*, 109–128. [[CrossRef](#)]
12. Huang, S.; Zhou, B.; Li, C.; Wu, Q.; Xia, S.; Wang, H.; Yang, H. Fractional-order modeling and sliding mode control of energy-saving and emission-reduction dynamic evolution system. *Int. J. Electr. Power Energy Syst.* **2018**, *100*, 400–410. [[CrossRef](#)]
13. Wang, X.; Wei, X.; Meng, Y. Experiment on Grid-Connection Process of Wind Turbines in Fractional Frequency Wind Power System. *IEEE Trans. Energy Convers.* **2015**, *30*, 22–31. [[CrossRef](#)]
14. Sondhi, S.; Hote, Y. V Fractional order PID controller for perturbed load frequency control using Kharitonov's theorem. *Int. J. Electr. Power Energy Syst.* **2016**, *78*, 884–896. [[CrossRef](#)]
15. Aghababa, M.P.; Haghghi, A.R.; Roohi, M. Stabilisation of unknown fractional-order chaotic systems: An adaptive switching control strategy with application to power systems. *IET Gener. Transm. Distrib.* **2015**, *9*, 1883–1893. [[CrossRef](#)]
16. Aghababa, M.P. Fractional modeling and control of a complex nonlinear energy supply-demand system. *Complexity* **2015**, *20*, 74–86. [[CrossRef](#)]
17. Borah, M.; Roy, B.K. Dynamics of the fractional-order chaotic PMSG, its stabilisation using predictive control and circuit validation. *IET Electr. Power Appl.* **2017**, *11*, 707–716. [[CrossRef](#)]
18. Mohanty, A.; Viswavandya, M.; Mohanty, S. An optimised FOPID controller for dynamic voltage stability and reactive power management in a stand-alone micro grid. *Int. J. Electr. Power Energy Syst.* **2016**, *78*, 524–536. [[CrossRef](#)]
19. Liu, L.; Qian, J.; Hua, L.; Zhang, B. System estimation of the SOFCs using fractional-order social network search algorithm. *Energy* **2022**, *255*, 124516. [[CrossRef](#)]
20. Ye, L.; Peng, D.; Xue, D.; Chen, S.; Shi, A. Co-estimation of lithium-ion battery state-of-charge and state-of-health based on fractional-order model. *J. Energy Storage* **2023**, *65*, 107225. [[CrossRef](#)]
21. Chen, L.; Wang, S.; Jiang, H.; Fernandez, C. A novel combined estimation method for state of energy and predicted maximum available energy based on fractional-order modeling. *J. Energy Storage* **2023**, *62*, 106930. [[CrossRef](#)]
22. Ma, L.; Xu, Y.; Zhang, H.; Yang, F.; Wang, X.; Li, C. Co-estimation of state of charge and state of health for lithium-ion batteries based on fractional-order model with multi-innovations unscented Kalman filter method. *J. Energy Storage* **2022**, *52*, 104904. [[CrossRef](#)]
23. Liu, S.; Sun, H.; Yu, H.; Miao, J.; Zheng, C.; Zhang, X. A framework for battery temperature estimation based on fractional electro-thermal coupling model. *J. Energy Storage* **2023**, *63*, 107042. [[CrossRef](#)]
24. Raheem, A.; Afreen, A.; Khatoun, A. Multi-term time-fractional stochastic system with multiple delays in control. *Chaos Solitons Fractals* **2023**, *167*, 112979. [[CrossRef](#)]
25. Mousavi, Y.; Bevan, G.; Kucukdemiral, I.B.; Fekih, A. Sliding mode control of wind energy conversion systems: Trends and applications. *Renew. Sustain. Energy Rev.* **2022**, *167*, 112734. [[CrossRef](#)]

26. Darvish Falehi, A.; Torkaman, H. Promoted supercapacitor control scheme based on robust fractional-order super-twisting sliding mode control for dynamic voltage restorer to enhance FRT and PQ capabilities of DFIG-based wind turbine. *J. Energy Storage* **2021**, *42*, 102983. [[CrossRef](#)]
27. Girgis, M.E.; Fahmy, R.A.; Badr, R.I. Optimal fractional-order PID control for plasma shape, position, and current in Tokamaks. *Fusion Eng. Des.* **2020**, *150*, 111361. [[CrossRef](#)]
28. Gao, Q.; Cai, J.; Liu, Y.; Chen, Y.; Shi, L.; Xu, W. Power mapping-based stability analysis and order adjustment control for fractional-order multiple delayed systems. *ISA Trans.* **2023**, *Online ahead of print*. [[CrossRef](#)]
29. Lusekelo, E.; Helikumi, M.; Kuznetsov, D.; Mushayabasa, S. Dynamic modelling and optimal control analysis of a fractional order chikungunya disease model with temperature effects. *Results Control Optim.* **2023**, *10*, 100206. [[CrossRef](#)]
30. Barry, L.E.; O'Neill, C.; Butler, C.; Chaudhuri, R.; Heaney, L.G. Cost-Effectiveness of Fractional Exhaled Nitric Oxide Suppression Testing as an Adherence Screening Tool Among Patients With Difficult-to-Control Asthma. *J. Allergy Clin. Immunol. Pract.* **2023**, *Online ahead of print*. [[CrossRef](#)]
31. Huang, S.; Wang, J.; Huang, C.; Zhou, L.; Xiong, L.; Liu, J.; Li, P. A fixed-time fractional-order sliding mode control strategy for power quality enhancement of PMSG wind turbine. *Int. J. Electr. Power Energy Syst.* **2022**, *134*, 107354. [[CrossRef](#)]
32. Hao, J.; Wang, J.; Yu, D.; Zhu, J.; Moattari, M. Fractional-order pathfinder algorithm for optimum design of an HRES based on photovoltaic and proton exchange membrane fuel cell: A case study. *Int. J. Hydrogen Energy*, **2023**; in press. [[CrossRef](#)]
33. Zhang, Q.; Shang, Y.; Li, Y.; Cui, N.; Duan, B.; Zhang, C. A novel fractional variable-order equivalent circuit model and parameter identification of electric vehicle Li-ion batteries. *ISA Trans.* **2020**, *97*, 448–457. [[CrossRef](#)]
34. Yang, B.; Wang, J.; Sang, Y.; Yu, L.; Shu, H.; Li, S.; He, T.; Yang, L.; Zhang, X.; Yu, T. Applications of supercapacitor energy storage systems in microgrid with distributed generators via passive fractional-order sliding-mode control. *Energy* **2019**, *187*, 115905. [[CrossRef](#)]
35. Statistical Review of World Energy. 2022. Available online: [www.bp.com](http://www.bp.com) (accessed on 1 June 2022).
36. François, B.; Puspitarini, H.D.; Volpi, E.; Borga, M. Statistical analysis of electricity supply deficits from renewable energy sources across an Alpine transect. *Renew. Energy* **2022**, *201*, 1200–1212. [[CrossRef](#)]
37. Alilou, M.; Toosi, B.; Shayeghi, H. Multi-objective unit and load commitment in smart homes considering uncertainties. *Int. Trans. Electr. Energy Syst.* **2020**, *30*, e12614. [[CrossRef](#)]
38. Singh, S.; Tayal, V.K.; Singh, H.P.; Yadav, V.K. Fractional Control Design of Renewable Energy Systems. In Proceedings of the ICRITO 2020 8th International Conference on Reliability, Infocom Technologies and Optimization (Trends and Future Directions), Noida, India, 4–5 June 2020; pp. 1246–1251. [[CrossRef](#)]
39. Azami, H.; Alizadeh, B.A.M.; Abapour, M. Optimal Smart Home Scheduling with Considering Hybrid Resource Management. In Proceedings of the 2021 11th Smart Grid Conference (SGC), Tabriz, Iran, 7–9 December 2021. [[CrossRef](#)]
40. Thangam, T.; Muthuvel, M.K. Passive Fractional-order Proportional-Integral-Derivative control design of a Grid-connected Photovoltaic inverter for Maximum Power Point Tracking. *Comput. Electr. Eng.* **2022**, *97*, 107657. [[CrossRef](#)]
41. Oshnoei, S.; Oshnoei, A.; Mosallanejad, A.; Haghjoo, F. Contribution of GCSC to regulate the frequency in multi-area power systems considering time delays: A new control outline based on fractional order controllers. *Int. J. Electr. Power Energy Syst.* **2020**, *123*, 106197. [[CrossRef](#)]
42. Oshnoei, S.; Aghamohammadi, M.; Oshnoei, S.; Oshnoei, A.; Mohammadi-Ivatloo, B. Provision of Frequency Stability of an Islanded Microgrid Using a Novel Virtual Inertia Control and a Fractional Order Cascade Controller. *Energies* **2021**, *14*, 4152. [[CrossRef](#)]
43. Suo, J.; Shi, M.; Li, Y.; Yang, Y. Proportional-integral control for synchronization of complex dynamical networks under dynamic event-triggered mechanism. *J. Frankl. Inst.* **2023**, *360*, 1436–1453. [[CrossRef](#)]
44. Çelik, E.; Öztürk, N. Novel fuzzy 1PD-TI controller for AGC of interconnected electric power systems with renewable power generation and energy storage devices. *Eng. Sci. Technol. Int. J.* **2022**, *35*, 101166. [[CrossRef](#)]
45. Aryan, P.; Raja, G.L. Restructured LFC Scheme with Renewables and EV Penetration using Novel QOEA Optimized Parallel Fuzzy I-PID Controller. *IFAC-Pap.* **2022**, *55*, 460–466. [[CrossRef](#)]
46. Oberlin, P.; Rathinam, S.; Darbha, S. A transformation for a Heterogeneous, Multiple Depot, Multiple Traveling Salesman Problem. In Proceedings of the 2009 American Control Conference, Saint Louis, Mo, USA, 10–12 June 2009; IEEE: New York, NY, USA, 2009; pp. 1292–1297.
47. Oshnoei, A.; Sadeghian, O.; Anvari-Moghaddam, A. Intelligent Power Control of Inverter Air Conditioners in Power Systems: A Brain Emotional Learning-Based Approach. *IEEE Trans. Power Syst.* **2022**, 1–15. [[CrossRef](#)]
48. Yang, S.; Wan, M.P.; Chen, W.; Ng, B.F.; Dubey, S. Model predictive control with adaptive machine-learning-based model for building energy efficiency and comfort optimization. *Appl. Energy* **2020**, *271*, 115147. [[CrossRef](#)]
49. Oshnoei, A.; Kheradmandi, M.; Muyeen, S.M. Robust Control Scheme for Distributed Battery Energy Storage Systems in Load Frequency Control. *IEEE Trans. Power Syst.* **2020**, *35*, 4781–4791. [[CrossRef](#)]
50. Oshnoei, A.; Khezri, R.; Muyeen, S.M.; Oshnoei, S.; Blaabjerg, F. Automatic Generation Control Incorporating Electric Vehicles. *Electr. Power Compon. Syst.* **2019**, *47*, 720–732. [[CrossRef](#)]
51. Oshnoei, S.; Oshnoei, A.; Mosallanejad, A.; Haghjoo, F. Novel load frequency control scheme for an interconnected two-area power system including wind turbine generation and redox flow battery. *Int. J. Electr. Power Energy Syst.* **2021**, *130*, 107033. [[CrossRef](#)]

52. Al-Dhaifallah, M.; Nassef, A.M.; Rezk, H.; Nisar, K.S. Optimal parameter design of fractional order control based INC-MPPT for PV system. *Sol. Energy* **2018**, *159*, 650–664. [[CrossRef](#)]
53. Ahmed, E.M.; Selim, A.; Mohamed, E.A.; Aly, M.; Alnuman, H.; Ramadan, H.A. Modified manta ray foraging optimization algorithm based improved load frequency controller for interconnected microgrids. *IET Renew. Power Gener.* **2022**, *16*, 3587–3613. [[CrossRef](#)]
54. Ahmed, E.M.; Elmelegi, A.; Shawky, A.; Aly, M.; Alhosaini, W.; Mohamed, E.A. Frequency Regulation of Electric Vehicle-Penetrated Power System Using MPA-Tuned New Combined Fractional Order Controllers. *IEEE Access* **2021**, *9*, 107548–107565. [[CrossRef](#)]
55. Song, K.; Hu, D.; Tong, Y.; Yue, X. Remaining life prediction of lithium-ion batteries based on health management: A review. *J. Energy Storage* **2023**, *57*, 106193. [[CrossRef](#)]
56. Bhat, M.Y.; Hashmi, S.A.; Khan, M.; Choi, D.; Qurashi, A. Frontiers and recent developments on supercapacitor's materials, design, and applications: Transport and power system applications. *J. Energy Storage* **2023**, *58*, 106104. [[CrossRef](#)]
57. Elkasem, A.H.A.; Khamies, M.; Hassan, M.H.; Agwa, A.M.; Kamel, S. Optimal Design of TD-TI Controller for LFC Considering Renewables Penetration by an Improved Chaos Game Optimizer. *Fractal Fract.* **2022**, *6*, 220. [[CrossRef](#)]
58. Chen, Y.; Li, R.; Sun, Z.; Zhao, L.; Guo, X. SOC estimation of retired lithium-ion batteries for electric vehicle with improved particle filter by H-infinity filter. *Energy Rep.* **2023**, *9*, 1937–1947. [[CrossRef](#)]
59. Shrivastava, P.; Soon, T.K.; Bin Idris, M.Y.I.; Mekhilef, S.; Adnan, S.B.R.S. Comprehensive co-estimation of lithium-ion battery state of charge, state of energy, state of power, maximum available capacity, and maximum available energy. *J. Energy Storage* **2022**, *56*, 106049. [[CrossRef](#)]
60. Sheng, C.; Fu, J.; Li, D.; Jiang, C.; Guo, Z.; Li, B.; Lei, J.; Zeng, L.; Deng, Z.; Fu, X.; et al. Energy management strategy based on health state for a PEMFC/Lithium-ion batteries hybrid power system. *Energy Convers. Manag.* **2022**, *271*, 116330. [[CrossRef](#)]
61. Chen, L.; Wu, X.; Tenreiro Machado, J.A.; Lopes, A.M.; Li, P.; Dong, X. State-of-Charge Estimation of Lithium-Ion Batteries Based on Fractional-Order Square-Root Unscented Kalman Filter. *Fractal Fract.* **2022**, *6*, 52. [[CrossRef](#)]
62. Chen, J.; Feng, X.; Jiang, L.; Zhu, Q. State of charge estimation of lithium-ion battery using denoising autoencoder and gated recurrent unit recurrent neural network. *Energy* **2021**, *227*, 120451. [[CrossRef](#)]
63. Wang, X.; Sun, Q.; Kou, X.; Ma, W.; Zhang, H.; Liu, R. Noise immune state of charge estimation of li-ion battery via the extreme learning machine with mixture generalized maximum correntropy criterion. *Energy* **2022**, *239*, 122406. [[CrossRef](#)]
64. Li, X.; Wang, Z.; Zhang, L. Co-estimation of capacity and state-of-charge for lithium-ion batteries in electric vehicles. *Energy* **2019**, *174*, 33–44. [[CrossRef](#)]
65. Ma, Y.; Duan, P.; Sun, Y.; Chen, H. Equalization of Lithium-Ion Battery Pack Based on Fuzzy Logic Control in Electric Vehicle. *IEEE Trans. Ind. Electron.* **2018**, *65*, 6762–6771. [[CrossRef](#)]
66. Xing, Y.; He, W.; Pecht, M.; Tsui, K.L. State of charge estimation of lithium-ion batteries using the open-circuit voltage at various ambient temperatures. *Appl. Energy* **2014**, *113*, 106–115. [[CrossRef](#)]
67. Xu, J.; Mi, C.C.; Cao, B.; Deng, J.; Chen, Z.; Li, S. The State of Charge Estimation of Lithium-Ion Batteries Based on a Proportional-Integral Observer. *IEEE Trans. Veh. Technol.* **2014**, *63*, 1614–1621. [[CrossRef](#)]
68. Hubert, A.; Forgez, C.; Yvars, P.-A. Designing the architecture of electrochemical energy storage systems. A model-based system synthesis approach. *J. Energy Storage* **2022**, *54*, 105351. [[CrossRef](#)]
69. Mohammed, A.; Ghaithan, A.M.; Al-Hanbali, A.; Attia, A.M. A multi-objective optimization model based on mixed integer linear programming for sizing a hybrid PV-hydrogen storage system. *Int. J. Hydrogen Energy* **2022**, *48*, 9748–9761. [[CrossRef](#)]
70. Shi, Q.; Guo, Z.; Wang, S.; Yan, S.; Zhou, X.; Li, H.; Wang, K.; Jiang, K. Physics-based fractional-order model and parameters identification of liquid metal battery. *Electrochim. Acta* **2022**, *428*, 140916. [[CrossRef](#)]
71. Bingi, K.; Rajanarayan Prusty, B.; Pal Singh, A. A Review on Fractional-Order Modelling and Control of Robotic Manipulators. *Fractal Fract.* **2023**, *7*, 77. [[CrossRef](#)]
72. Daraz, A.; Malik, S.A.; Basit, A.; Aslam, S.; Zhang, G. Modified FOPID Controller for Frequency Regulation of a Hybrid Interconnected System of Conventional and Renewable Energy Sources. *Fractal Fract.* **2023**, *7*, 89. [[CrossRef](#)]
73. Ali, F.; Iftikhar, M.; Khan, I.; Sheikh, N.A.; Aamina; Nisar, K.S. Time fractional analysis of electro-osmotic flow of Walters's-B fluid with time-dependent temperature and concentration. *Alex. Eng. J.* **2020**, *59*, 25–38. [[CrossRef](#)]
74. Kaleem, M.M.; Usman, M.; Asjad, M.I.; Eldin, S.M. Magnetic Field, Variable Thermal Conductivity, Thermal Radiation, and Viscous Dissipation Effect on Heat and Momentum of Fractional Oldroyd-B Bio Nano-Fluid within a Channel. *Fractal Fract.* **2022**, *6*, 712. [[CrossRef](#)]
75. Eyebe, G.J.; Betchewe, G.; Mohamadou, A.; Kofane, T.C. Nonlinear Vibration of a Nonlocal Nanobeam Resting on Fractional-Order Viscoelastic Pasternak Foundations. *Fractal Fract.* **2018**, *2*, 21. [[CrossRef](#)]
76. Alazman, I.; Alkahtani, B.S.T. Investigation of Novel Piecewise Fractional Mathematical Model for COVID-19. *Fractal Fract.* **2022**, *6*, 661. [[CrossRef](#)]
77. Sajid, M.; Chaudhary, H.; Allahem, A.; Kaushik, S. Chaos Controllability in Fractional-Order Systems via Active Dual Combination&dash;Combination Hybrid Synchronization Strategy. *Fractal Fract.* **2022**, *6*, 717. [[CrossRef](#)]
78. Bertias, P.; Psychalinos, C.; Minaei, S.; Yesil, A.; Elwakil, A.S. Fractional-order inverse filters revisited: Equivalence with fractional-order controllers. *Microelectron. J.* **2023**, *131*, 105646. [[CrossRef](#)]



79. Meng, X.; Jiang, B.; Karimi, H.R.; Gao, C. An event-triggered mechanism to observer-based sliding mode control of fractional-order uncertain switched systems. *ISA Trans.* **2022**, *135*, 115–129. [[CrossRef](#)] [[PubMed](#)]
80. Xu, Y.; Zhang, H.; Zhang, J.; Yang, F.; Tong, L.; Yan, D.; Yang, H.; Wang, Y. State of charge estimation under different temperatures using unscented Kalman filter algorithm based on fractional-order model with multi-innovation. *J. Energy Storage* **2022**, *56*, 106101. [[CrossRef](#)]
81. Jin, X.-C.; Lu, J.-G.; Zhang, Q.-H. Delay-dependent and order-dependent conditions for stability and stabilization of fractional-order memristive neural networks with time-varying delays. *Neurocomputing* **2023**, *522*, 53–63. [[CrossRef](#)]
82. Ortigueira, M.D.; Rodríguez-Germá, L.; Trujillo, J.J. Complex Grünwald–Letnikov, Liouville, Riemann–Liouville, and Caputo derivatives for analytic functions. *Commun. Nonlinear Sci. Numer. Simul.* **2011**, *16*, 4174–4182. [[CrossRef](#)]
83. Scherer, R.; Kalla, S.L.; Tang, Y.; Huang, J. The Grünwald–Letnikov method for fractional differential equations. *Comput. Math. Appl.* **2011**, *62*, 902–917. [[CrossRef](#)]
84. Haq, A.; Sukavanam, N. Existence and partial approximate controllability of nonlinear Riemann–Liouville fractional systems of higher order. *Chaos Solitons Fractals* **2022**, *165*, 112783. [[CrossRef](#)]
85. Turkyilmazoglu, M.; Altanji, M. Fractional models of falling object with linear and quadratic frictional forces considering Caputo derivative. *Chaos Solitons Fractals* **2023**, *166*, 112980. [[CrossRef](#)]
86. Shukla, K.; Sapra, P. Fractional Calculus and Its Applications for Scientific Professionals: A Literature Review. *Int. J. Mod. Math. Sci.* **2019**, *17*, 111–137.
87. Frikh, M.L.; Soltani, F.; Bensiali, N.; Boutasseta, N.; Fergani, N. Fractional order PID controller design for wind turbine systems using analytical and computational tuning approaches. *Comput. Electr. Eng.* **2021**, *95*, 107410. [[CrossRef](#)]
88. Dudhe, S.; Kumar Dheer, D.; Lloyds Raja, G. Modeling and control of suction pressure in portable meconium aspirator system using fractional order IMC-PID controller and RDR techniques. *Mater. Today Proc.* **2023**, *80*, 320–326. [[CrossRef](#)]
89. Xu, D.; Chen, Y.; Systems, I. A comparative introduction of four fractional order controllers. In Proceedings of the 4th World Congress on Intelligent Control and Automation, online, 10–14 June 2002; pp. 3228–3235.
90. Hasan, R.; Masud, M.S.; Haque, N.; Abdussami, M.R. Frequency control of nuclear-renewable hybrid energy systems using optimal PID and FOPID controllers. *Heliyon* **2022**, *8*, e11770. [[CrossRef](#)] [[PubMed](#)]
91. Yumuk, E.; Güzelkaya, M.; Eksin, İ. Analytical fractional PID controller design based on Bode’s ideal transfer function plus time delay. *ISA Trans.* **2019**, *91*, 196–206. [[CrossRef](#)]
92. Kumar, A.; Kumar, V. Hybridized ABC-GA optimized fractional order fuzzy pre-compensated FOPID control design for 2-DOF robot manipulator. *AEU-Int. J. Electron. Commun.* **2017**, *79*, 219–233. [[CrossRef](#)]
93. Dastjerdi, A.A.; Vinagre, B.M.; Chen, Y.Q.; HosseinNia, S.H. Linear fractional order controllers; A survey in the frequency domain. *Annu. Rev. Control* **2019**, *47*, 51–70. [[CrossRef](#)]
94. Vanitha, D.; Rathinakumar, M. Fractional order PID controlled PV buck boost converter with coupled inductor. *Int. J. Power Electron. Drive Syst.* **2017**, *8*, 1401–1407.
95. Soriano-Sánchez, A.G.; Rodríguez-Licea, M.A.; Pérez-Pinal, F.J.; Vázquez-López, J.A. Fractional-order approximation and synthesis of a PID controller for a buck converter. *Energies* **2020**, *13*, 629. [[CrossRef](#)]
96. Mollae, H.; Ghamari, S.M.; Saadat, S.A.; Wheeler, P. A novel adaptive cascade controller design on a buck–boost DC–DC converter with a fractional-order PID voltage controller and a self-tuning regulator adaptive current controller. *IET Power Electron.* **2021**, *14*, 1920–1935. [[CrossRef](#)]
97. Wei, Z.; Zhang, B.; Jiang, Y. Analysis and Modeling of Fractional-Order Buck Converter Based on Riemann-Liouville Derivative. *IEEE Access* **2019**, *7*, 162768–162777. [[CrossRef](#)]
98. Kumar, V.A.; Mouttou, A. Improved performance with fractional order control for asymmetrical cascaded h-bridge multilevel inverter. *Bull. Electr. Eng. Inform.* **2020**, *9*, 1335–1344. [[CrossRef](#)]
99. Silva Júnior, D.C.; Oliveira, J.G.; de Almeida, P.M.; Boström, C. Control of a multi-functional inverter in an AC microgrid–Real-time simulation with control hardware in the loop. *Electr. Power Syst. Res.* **2019**, *172*, 201–212. [[CrossRef](#)]
100. Lai, J.; Yin, X.; Yin, X.; Jiang, L. Fractional order harmonic disturbance observer control for three-phase LCL-type inverter. *Control Eng. Pract.* **2021**, *107*, 104697. [[CrossRef](#)]
101. Arulmurugan, R.; Suthanthiravanitha, N. Improved Fractional Order VSS Inc-Cond MPPT Algorithm for Photovoltaic Scheme. *Int. J. Photoenergy* **2014**, *2014*, 1–10. [[CrossRef](#)]
102. Yang, B.; Yu, T.; Shu, H.; Zhu, D.; Zeng, F.; Sang, Y.; Jiang, L. Perturbation observer based fractional-order PID control of photovoltaics inverters for solar energy harvesting via Yin-Yang-Pair optimization. *Energy Convers. Manag.* **2018**, *171*, 170–187. [[CrossRef](#)]
103. Tasnin, W.; Saikia, L.C.; Raju, M. Deregulated AGC of multi-area system incorporating dish-Stirling solar thermal and geothermal power plants using fractional order cascade controller. *Int. J. Electr. Power Energy Syst.* **2018**, *101*, 60–74. [[CrossRef](#)]
104. Nosrati, K.; Mansouri, H.R.; Saboori, H. Fractional-order PID controller design of frequency deviation in a hybrid renewable energy generation and storage system. *CIREN-Open Access Proc. J.* **2017**, *2017*, 1148–1152. [[CrossRef](#)]
105. Pan, I.; Das, S. Fractional order fuzzy control of hybrid power system with renewable generation using chaotic PSO. *ISA Trans.* **2016**, *62*, 19–29. [[CrossRef](#)]
106. Gül, O.; Tan, N. Application of fractional-order voltage controller in building-integrated photovoltaic and wind turbine system. *Meas. Control* **2019**, *52*, 1145–1158. [[CrossRef](#)]

107. Pathak, D.; Gaur, P. A fractional order fuzzy-proportional-integral-derivative based pitch angle controller for a direct-drive wind energy system. *Comput. Electr. Eng.* **2019**, *78*, 420–436. [[CrossRef](#)]
108. Asgharnia, A.; Jamali, A.; Shahnaazi, R.; Maheri, A. Load mitigation of a class of 5-MW wind turbine with RBF neural network based fractional-order PID controller. *ISA Trans.* **2020**, *96*, 272–286. [[CrossRef](#)] [[PubMed](#)]
109. Beschi, M.; Padula, F.; Visioli, A. Fractional robust PID control of a solar furnace. *Control Eng. Pract.* **2016**, *56*, 190–199. [[CrossRef](#)]
110. Sahin, E. A PSO Optimized Fractional-Order PID Controller for a PV System with DC-DC Boost Converter. In Proceedings of the 2014 16th International Power Electronics and Motion Control Conference and Exposition, Antalya, Turkey, 21–24 September 2014; pp. 477–481.
111. Ramadan, H.S. Optimal fractional order PI control applicability for enhanced dynamic behavior of on-grid solar PV systems. *Int. J. Hydrogen Energy* **2017**, *42*, 4017–4031. [[CrossRef](#)]
112. Ahmed, E.M.; Member, S.; Mohamed, E.A.; Elmelegi, A. Optimum Modified Fractional Order Controller for Future Electric Vehicles and Renewable Energy-Based Interconnected Power Systems. *IEEE Access* **2021**, *9*, 29993–30010. [[CrossRef](#)]
113. Elmelegi, A.; Mohamed, E.A.; Aly, M.; Ahmed, E.M.; Mohamed, A.A.A.; Elbaksawi, O. Optimized Tilt Fractional Order Cooperative Controllers for Preserving Frequency Stability in Renewable Energy-Based Power Systems. *IEEE Access* **2021**, *9*, 8261–8277. [[CrossRef](#)]
114. Fathy, A.; Rezk, H.; Ferahtia, S.; Ghoniem, R.M.; Alkanhel, R.; Ghoniem, M.M. A New Fractional-Order Load Frequency Control for Multi-Renewable Energy Interconnected Plants Using Skill Optimization Algorithm. *Sustainability* **2022**, *14*, 14999. [[CrossRef](#)]
115. Daraz, A.; Malik, S.A.; Azar, A.T.; Aslam, S.; Alkhalifah, T.; Alturise, F. Optimized Fractional Order Integral-Tilt Derivative Controller for Frequency Regulation of Interconnected Diverse Renewable Energy Resources. *IEEE Access* **2022**, *10*, 43514–43527. [[CrossRef](#)]
116. Mohamed, E.A.; Ahmed, E.M.; Elmelegi, A.; Aly, M.; Elbaksawi, O.; Mohamed, A.A.A. An Optimized Hybrid Fractional Order Controller for Frequency Regulation in Multi-Area Power Systems. *IEEE Access* **2020**, *8*, 213899–213915. [[CrossRef](#)]
117. Yu, K.N.; Liao, C.K.; Yau, H.T. A New Fractional-Order Based Intelligent Maximum Power Point Tracking Control Algorithm for Photovoltaic Power Systems. *Int. J. Photoenergy* **2015**, *2015*, 1–8. [[CrossRef](#)]
118. Yang, B.; Yu, T.; Shu, H.; Zhu, D.; An, N.; Sang, Y.; Jiang, L. Energy reshaping based passive fractional-order PID control design and implementation of a grid-connected PV inverter for MPPT using grouped grey wolf optimizer. *Sol. Energy* **2018**, *170*, 31–46. [[CrossRef](#)]
119. Mu, H.; Xiong, R.; Zheng, H.; Chang, Y.; Chen, Z. A novel fractional order model based state-of-charge estimation method for lithium-ion battery. *Appl. Energy* **2017**, *207*, 384–393. [[CrossRef](#)]
120. Wang, Y.; Li, M.; Chen, Z. Experimental study of fractional-order models for lithium-ion battery and ultra-capacitor: Modeling, system identification, and validation. *Appl. Energy* **2020**, *278*, 115736. [[CrossRef](#)]
121. Guo, R.; Shen, W. Online state of charge and state of power co-estimation of lithium-ion batteries based on fractional-order calculus and model predictive control theory. *Appl. Energy* **2022**, *327*, 120009. [[CrossRef](#)]
122. Chen, L.; Guo, W.; Lopes, A.M.; Wu, R.; Li, P.; Yin, L. State-of-charge estimation for lithium-ion batteries based on incommensurate fractional-order observer. *Commun. Nonlinear Sci. Numer. Simul.* **2023**, *118*, 107059. [[CrossRef](#)]
123. Xu, C.; Cheng, S.; Wang, K.; Jiang, K. A Fractional-order Model for Liquid Metal Batteries. *Energy Procedia* **2019**, *158*, 4690–4695. [[CrossRef](#)]
124. Lu, X.; Li, H.; Chen, N. An indicator for the electrode aging of lithium-ion batteries using a fractional variable order model. *Electrochim. Acta* **2019**, *299*, 378–387. [[CrossRef](#)]
125. Ruan, H.; Sun, B.; Jiang, J.; Zhang, W.; He, X.; Su, X.; Bian, J.; Gao, W. A modified-electrochemical impedance spectroscopy-based multi-time-scale fractional-order model for lithium-ion batteries. *Electrochim. Acta* **2021**, *394*, 139066. [[CrossRef](#)]
126. Zhu, G.; Kong, C.; Wang, J.V.; Kang, J.; Yang, G.; Wang, Q. A fractional-order model of lithium-ion battery considering polarization in electrolyte and thermal effect. *Electrochim. Acta* **2023**, *438*, 141461. [[CrossRef](#)]
127. Fouda, M.E.; Elwakil, A.S.; Radwan, A.G.; Allagui, A. Power and energy analysis of fractional-order electrical energy storage devices. *Energy* **2016**, *111*, 785–792. [[CrossRef](#)]
128. Zhu, Q.; Xu, M.; Liu, W.; Zheng, M. A state of charge estimation method for lithium-ion batteries based on fractional order adaptive extended kalman filter. *Energy* **2019**, *187*, 115880. [[CrossRef](#)]
129. Yang, B.; Zhu, T.; Zhang, X.; Wang, J.; Shu, H.; Li, S.; He, T.; Yang, L.; Yu, T. Design and implementation of Battery/SMES hybrid energy storage systems used in electric vehicles: A nonlinear robust fractional-order control approach. *Energy* **2020**, *191*, 116510. [[CrossRef](#)]
130. He, L.; Wang, Y.; Wei, Y.; Wang, M.; Hu, X.; Shi, Q. An adaptive central difference Kalman filter approach for state of charge estimation by fractional order model of lithium-ion battery. *Energy* **2022**, *244*, 122627. [[CrossRef](#)]
131. Guo, D.; Yang, G.; Feng, X.; Han, X.; Lu, L.; Ouyang, M. Physics-based fractional-order model with simplified solid phase diffusion of lithium-ion battery. *J. Energy Storage* **2020**, *30*, 101404. [[CrossRef](#)]
132. Li, S.; Li, Y.; Zhao, D.; Zhang, C. Adaptive state of charge estimation for lithium-ion batteries based on implementable fractional-order technology. *J. Energy Storage* **2020**, *32*, 101838. [[CrossRef](#)]
133. Liu, C.; Hu, M.; Jin, G.; Xu, Y.; Zhai, J. State of power estimation of lithium-ion battery based on fractional-order equivalent circuit model. *J. Energy Storage* **2021**, *41*, 102954. [[CrossRef](#)]

134. Solomon, O.O.; Zheng, W.; Chen, J.; Qiao, Z. State of charge estimation of Lithium-ion battery using an improved fractional-order extended Kalman filter. *J. Energy Storage* **2022**, *49*, 104007. [[CrossRef](#)]
135. Miao, Y.; Gao, Z. Estimation for state of charge of lithium-ion batteries by adaptive fractional-order unscented Kalman filters. *J. Energy Storage* **2022**, *51*, 104396. [[CrossRef](#)]
136. Zhang, L.; Wang, X.; Chen, M.; Yu, F.; Li, M. A fractional-order model of lithium-ion batteries and multi-domain parameter identification method. *J. Energy Storage* **2022**, *50*, 104595. [[CrossRef](#)]
137. Wu, J.; Fang, C.; Jin, Z.; Zhang, L.; Xing, J. A multi-scale fractional-order dual unscented Kalman filter based parameter and state of charge joint estimation method of lithium-ion battery. *J. Energy Storage* **2022**, *50*, 104666. [[CrossRef](#)]
138. Liu, Z.; Chen, S.; Jing, B.; Yang, C.; Ji, J.; Zhao, Z. Fractional variable-order calculus based state of charge estimation of Li-ion battery using dual fractional order Kalman filter. *J. Energy Storage* **2022**, *52*, 104685. [[CrossRef](#)]
139. Abdullaeva, B.; Oplencia, M.J.C.; Borisov, V.; Uktamov, K.F.; Abdelbasset, W.K.; Al-Nussair, A.K.J.; Abdulhasan, M.M.; Thangavelu, L.; Jabbar, A.H. Optimal variable estimation of a Li-ion battery model by fractional calculus and bio-inspired algorithms. *J. Energy Storage* **2022**, *54*, 105323. [[CrossRef](#)]
140. Guo, H.; Han, X.; Yang, R.; Shi, J. State of charge estimation for lithium-ion batteries based on fractional order multiscale algorithm. *J. Energy Storage* **2022**, *55*, 105630. [[CrossRef](#)]
141. Rodríguez-Iturriaga, P.; Alonso-del-Valle, J.; Rodríguez-Bolívar, S.; Anseán, D.; Viera, J.C.; López-Villanueva, J.A. A novel Dual Fractional-Order Extended Kalman Filter for the improved estimation of battery state of charge. *J. Energy Storage* **2022**, *56*, 105810. [[CrossRef](#)]
142. Mao, S.; Yu, Z.; Zhang, Z.; Lv, B.; Sun, Z.; Huai, R.; Chang, L.; Li, H. Parameter identification method for the variable order fractional-order equivalent model of lithium-ion battery. *J. Energy Storage* **2023**, *57*, 106273. [[CrossRef](#)]
143. Yang, B.; Wang, J.; Wang, J.; Shu, H.; Li, D.; Zeng, C.; Chen, Y.; Zhang, X.; Yu, T. Robust fractional-order PID control of supercapacitor energy storage systems for distribution network applications: A perturbation compensation based approach. *J. Clean. Prod.* **2021**, *279*, 123362. [[CrossRef](#)]
144. Yu, M.; Li, Y.; Podlubny, I.; Gong, F.; Sun, Y.; Zhang, Q.; Shang, Y.; Duan, B.; Zhang, C. Fractional-order modeling of lithium-ion batteries using additive noise assisted modeling and correlative information criterion. *J. Adv. Res.* **2020**, *25*, 49–56. [[CrossRef](#)] [[PubMed](#)]
145. Wang, B.; Li, S.E.; Peng, H.; Liu, Z. Fractional-order modeling and parameter identification for lithium-ion batteries. *J. Power Sources* **2015**, *293*, 151–161. [[CrossRef](#)]
146. Mawonou, K.S.R.; Eddahech, A.; Dumur, D.; Beauvois, D.; Godoy, E. Improved state of charge estimation for Li-ion batteries using fractional order extended Kalman filter. *J. Power Sources* **2019**, *435*, 226710. [[CrossRef](#)]
147. Sun, Y.; Li, Y.; Yu, M.; Zhou, Z.; Zhang, Q.; Duan, B.; Shang, Y.; Zhang, C. Variable fractional order-A comprehensive evaluation indicator of lithium-ion batteries. *J. Power Sources* **2020**, *448*, 227411. [[CrossRef](#)]
148. Wang, Y.; Gao, G.; Li, X.; Chen, Z. A fractional-order model-based state estimation approach for lithium-ion battery and ultra-capacitor hybrid power source system considering load trajectory. *J. Power Sources* **2020**, *449*, 227543. [[CrossRef](#)]
149. Saxena, A.; Shankar, R. Improved load frequency control considering dynamic demand regulated power system integrating renewable sources and hybrid energy storage system. *Sustain. Energy Technol. Assess.* **2022**, *52*, 102245. [[CrossRef](#)]
150. Prasad, E.N.V.D.V.; Sahani, M.; Dash, P.K. A new adaptive integral back stepping fractional order sliding mode control approach for PV and wind with battery system based DC microgrid. *Sustain. Energy Technol. Assess.* **2022**, *52*, 102261. [[CrossRef](#)]
151. Morsali, J. Fractional order control strategy for superconducting magnetic energy storage to take part effectually in automatic generation control issue of a realistic restructured power system. *J. Energy Storage* **2022**, *55*, 105764. [[CrossRef](#)]
152. Saha, S.K.; Takano, T.; Fushimi, K.; Sakairi, M.; Saito, R. Passivity of iron surface in curing cement paste environment investigated by electrochemical impedance spectroscopy and surface characterization techniques. *Surf. Interfaces* **2023**, *36*, 102549. [[CrossRef](#)]
153. Wang, L.; Zhao, X.; Deng, Z.; Yang, L. Application of electrochemical impedance spectroscopy in battery management system: State of charge estimation for aging batteries. *J. Energy Storage* **2023**, *57*, 106275. [[CrossRef](#)]

**Disclaimer/Publisher's Note:** The statements, opinions and data contained in all publications are solely those of the individual author(s) and contributor(s) and not of MDPI and/or the editor(s). MDPI and/or the editor(s) disclaim responsibility for any injury to people or property resulting from any ideas, methods, instructions or products referred to in the content.