



AALBORG UNIVERSITY
DENMARK

Aalborg Universitet

Wave Pressures on Seawave Slot-Cone Generator

Vicinanza, Diego; Kofoed, Jens Peter; Frigaard, Peter

Published in:

Proceedings of the 30th Italian Conference on Hydraulic Engineering

Publication date:

2006

Document Version

Early version, also known as pre-print

[Link to publication from Aalborg University](#)

Citation for published version (APA):

Vicinanza, D., Kofoed, J. P., & Frigaard, P. (2006). Wave Pressures on Seawave Slot-Cone Generator. In *Proceedings of the 30th Italian Conference on Hydraulic Engineering: IDRA 2006, Rome, 10-15 September 2006* Universita' degli studi di Roma "La Sapienza" : Universita' degli studi di "Roma tre".

General rights

Copyright and moral rights for the publications made accessible in the public portal are retained by the authors and/or other copyright owners and it is a condition of accessing publications that users recognise and abide by the legal requirements associated with these rights.

- Users may download and print one copy of any publication from the public portal for the purpose of private study or research.
- You may not further distribute the material or use it for any profit-making activity or commercial gain
- You may freely distribute the URL identifying the publication in the public portal -

Take down policy

If you believe that this document breaches copyright please contact us at vbn@aub.aau.dk providing details, and we will remove access to the work immediately and investigate your claim.

WAVE PRESSURES ON SEAWAVE SLOT-CONE GENERATOR

Diego Vicinanza¹, Jens Peter Kofoed¹, Peter Frigaard²

- (1) Dipartimento di Ingegneria Civile, Seconda Università degli studi di Napoli – Aversa (IT)
e-mail: diego.vicinanza@unina2.it
- (2) Department of Civil Engineering, Aalborg University – Aalborg (DK)
e-mails: jpk@civil.aau.dk, i5pf@civil.aau.dk

Keywords: Waves-Structures Interaction, Laboratory models, SSG breakwater, Sloping/Vertical walls, Statistical distribution, Pressures.

ABSTRACT

This paper presents results on loading acting on an innovative caisson breakwater for electricity production. The work reported here contributes to the European Union Sixth Framework programme priority 6.1 (Sustainable Energy System), contract 019831, titled "Full-scale demonstration of robust and high-efficiency wave energy converter" (WAVESSG). Information on wave loading acting on Wave Energy Convert (WEC) Seawave Slot-Cone Generator (SSG) exposed to extreme wave conditions are reported. The SSG concept is based on the known principle of overtopping and storing the wave energy in several reservoirs placed one above the other. Using this method practically all waves, regardless of size and speed are captured for energy production. In the present SSG setup three reservoirs have been used. Comprehensive 2D and 3D hydraulic model tests were carried out at the Department of Civil Engineering, Aalborg University (Denmark) in the 3D deep water wave tank. The model scale used was 1:60 of the SSG prototype at the planned location of a pilot plant at the west coast of the island Kvitsøy near Stavanger, Norway. The results of the tests have been compared with prediction methods. Results here discussed derive from preliminary analysis conducted using only a part of the whole data set. This study is intended to be of direct use for design and stability of the pilot plant under construction at Kvitsøy island funded by the EU 6th framework program (WAVESSG).

1 Introduction

As recently expressed by top European heads of state, the climate change is the largest challenge that we are facing today. Traditional sources of energy such as oil, gas and coal are not renewable over the span of human generations. They also cause pollution by releasing huge quantities of carbon dioxide and other pollutants into the atmosphere. Evidence suggests that these damage the environment in many ways, from acid rain to stoking up global warming. The Kyoto protocol regarding reduction of greenhouse gases and pollutant emissions (to below 1990 levels by 2008/2012) is strictly linked to the development of Renewable Energy Sources (RES).

To meet the greater need to integrate energy and environmental policies, engineers in coming decades will be challenged to economically generate power from renewable energy sources as waves.

Wave energy is a renewable and pollution-free energy source that has the potential world-wide contribution in the electricity market estimated in the order of 2,000 TWh/year, that represent about 10% of the world electricity consumption with an investment cost of EUR 820 billion (Thorpe, 1999).

Today, the largest problem in harvesting wave energy is obtaining reliability of the technology and bringing the cost down.

WAVEenergy AS company (Stavanger, Norway) was founded in April 2004 to develop the Seawave Slot-cone Generator (SSG) concept. The SSG is a wave energy converter based on the wave overtopping principle utilizing a total of three reservoirs placed on top of each other, in which the potential energy of the incoming wave will be stored (Fig. 1). The water captured in the reservoirs will then run through the

multi-stage turbine for electricity production. The use of multiple reservoirs will result in a higher overall efficiency, compared to a single reservoir structure (Kofoed, 2002; Kofoed, 2005; Kofoed & Osaland, 2005).

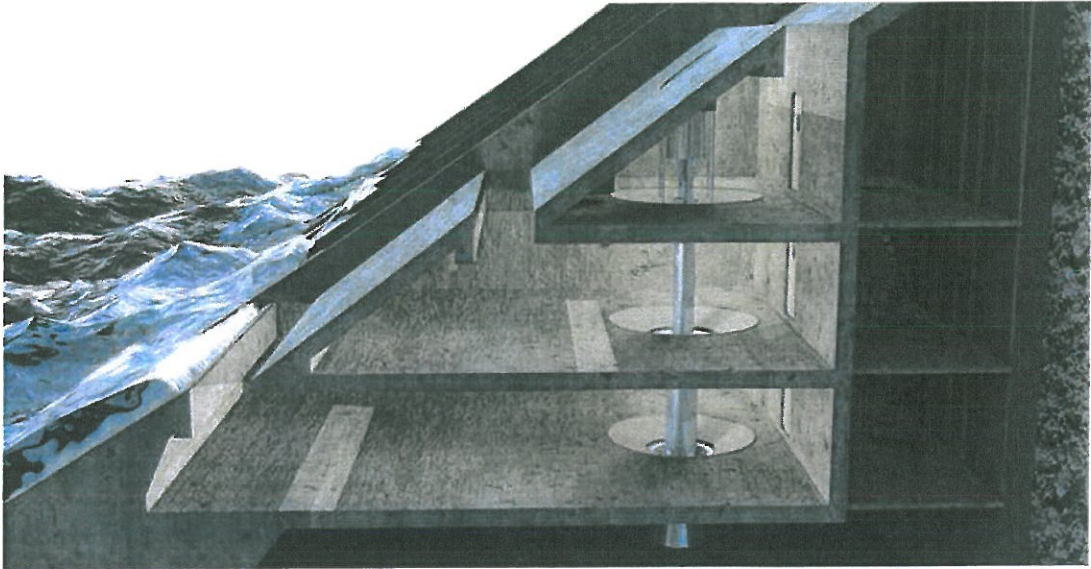

Figure 1. Scheme of Seawave Slot-Cone Generator (SSG).

WAVEnergy AS is currently carrying out a pilot project of the SSG wave converter at the island of Kvitstøy – Norway (Fig. 2), part funded by the European Commission (WAVESSG project). The Kvitstøy municipality has 520 inhabitants and is one of 10,000 islands in Europe where wave energy can quickly be developed into a cost effective energy production alternative to existing diesel generators.

The full-scale technical prototype of the SSG includes three reservoirs for capturing the ocean energy and is constructed as a robust shoreline device (Fig. 3). Preliminary estimate for the first commercial shoreline SSG is that a full scale SSG shoreline plant of 500 m length will be able to produce 10-20 GWh/year for a price of electricity of around 0,12 EUR/kWh in 2008. Such a price is already competitive with generation of electricity on islands by means of diesel-generators and in-line with payment schemes set up for wave energy in Portugal and Scotland. With further technical development and utilization of economies of scale, the forecasted ultimate price will be 0,04-0,06 EUR/kWh.

A key to success for the SSG will be low cost of the structure. The wave forces on the main structure can be estimated using experiences from coastal protection structures, but the differences between the structures are so large that more reliable knowledge on the wave forces is desired.

The purpose of the work described in this paper is to derive information on wave pressures/forces acting on sloping and vertical walls constituting the structure. The aim is to optimize the structural design and geometrical layout of the SSG under extreme wave conditions (Vicinanza *et al.*, 2006). Measurements of wave pressures planned at pilot SSG in Kvitstøy will be useful to estimate model-prototype scaling discrepancies.

2 Wave pressures on caisson breakwaters

2.1 Loading conditions

The forms and magnitudes of wave pressures/forces acting upon caisson breakwaters under random wave conditions are highly variable and they are conveniently divided into “pulsating”, when they are

slowly-varying in time and the pressure spatial gradients are relatively mild, and “impact”, when they are rapidly-varying in time and the pressure spatial gradients are extremely high (Allsop *et al.*, 1996; Vicinanza, 1997b; Calabrese & Vicinanza, 1999).

Quasi-static or pulsating wave pressures change relatively slowly, varying at rates of the same order of magnitude as the wave crest. Two principal quasi-static forces may be considered here. In the first, a wave crest impinges directly against the structure applying a hydro-static pressure difference. The obstruction of the momentum of the wave causes the wave surface to rise up the wall, increasing the pressure difference across the plates. The net force is approximately proportional to the wave height, and can be estimated using relatively simple methods.

Wave impacts occur when the waves break directly on the structure with almost vertical front surface at the moment of impact or as a plunging breaker with small or large cushion of air inducing loads of much greater intensity and shorter duration than the quasi-static loads. The pressure/force history generally exhibit an impulsive zone characterised by high pressures with shorter duration followed by a longer-lasting quasi-static force (Fig. 2).

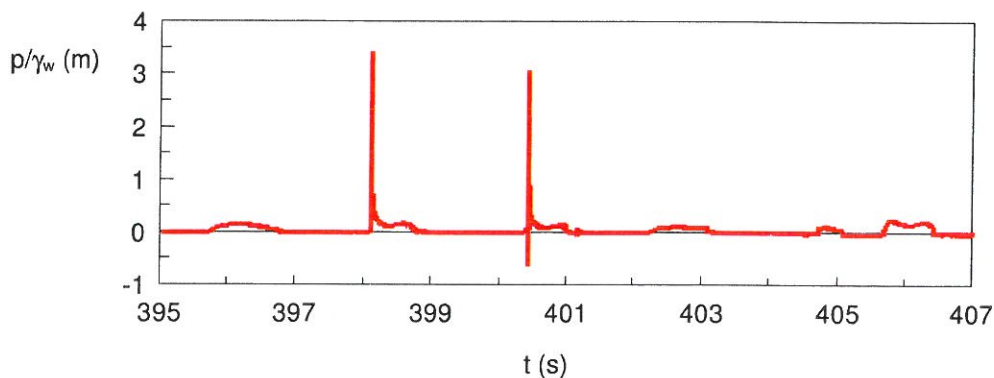

Figure 2. Quasi-static and impact pressure time history (after Vicinanza, 1997a, b).

Previous studies by Vicinanza (1997b, Calabrese & Vicinanza, 1999) have shown that it is possible to distinguish between impact and quasi-standing waves from the probability distributions of wave forces on the structure. In this approach, all forces are ranked and plotted on a Weibull paper. A reduce variate $u = f$ (Fhi) was adopted to build the probability paper related to each distribution examined*. Any significant departure of forces above the Weibull line is taken as indication of wave impacts. The percentage of impacts is given by the probability level, P , at which forces start to depart from the Weibull line. Where they follow the Weibull line, it is deemed that quasi-static conditions had occurred (Fig. 3).

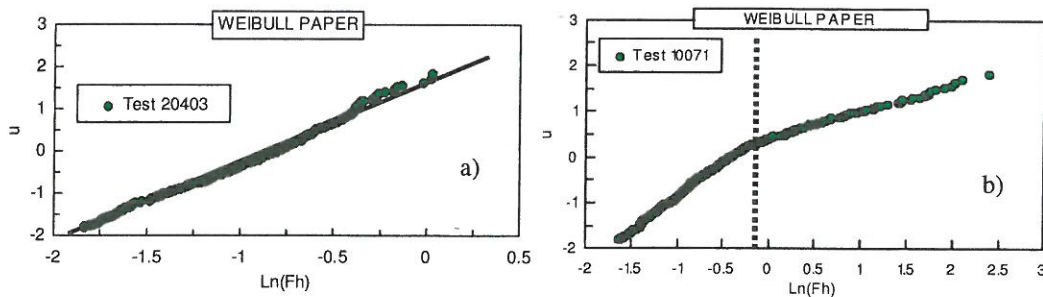

Figure 3. Weibull plot for conditions: a) quasi-static b) impact (after Vicinanza, 1997a, b).

* taking in account that is valid the condition $P(u) = P(Fhi)$.

2.2 Design formulae

Coastal engineering practice by the U.S. Army Corps of Engineers (USACE) and standard engineering for most coastal projects throughout the world have been based, wholly or in part, on the Coastal Engineering Manual (CEM, 2002). The methods described in the following section are not directly applicable to the tested SSG structure because of its new design. Anyway the prediction methods described are the engineering tools that comes closest.

2.2.1 Goda (1974, 1985)

The most widely used prediction method for wave forces on vertical walls was developed by *Goda* (1974, 1985). This method was primarily developed to calculate the horizontal force for concrete caissons on rubble mound foundations, and was calibrated against laboratory tests and back-analysis of historic failures. It assumes that wave pressures on the wall can be represented by a trapezoidal distribution, with the highest value at still water level, regardless of whether waves are breaking or non-breaking. In Europe, Goda's method is cited by British Standard BS6349 Pt 1, and by the Italian Standards (Istruzioni Tecniche per la Progettazione delle Dighe Marittime, 1996), and many national standards.

Goda's method represents wave pressure characteristics by considering two components, the breaking wave (impacts) and the deflected wave (slowly-varying or pulsating pressures), represented in the method by coefficients α_1 , α_2 , and α_3 . The influence of relative depth to wavelength on the slowly-varying component is represented by α_1 ; the effect of impulsive wave breaking due to the relative level of the mound is represented by α_2 ; and α_3 accounts for the relative crest level of the caisson and the relative water depth over the toe mound (Fig. 4).

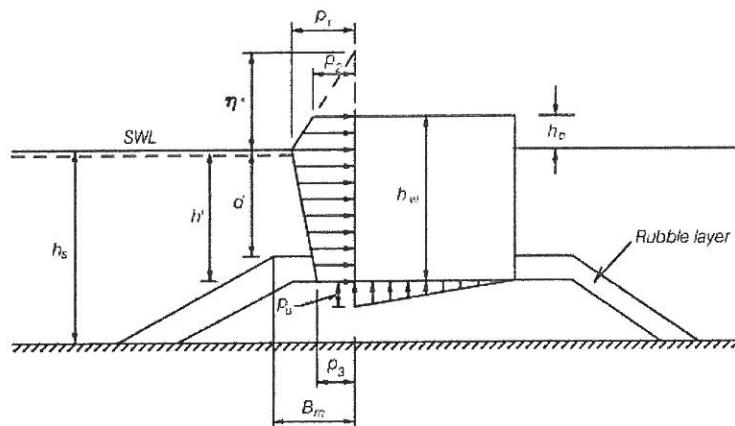

Figure 4. Pressure distribution on vertical walls after *Goda* (1974, 1985).

It is very important to notice that design wave height is defined as the highest wave in the design sea state at the location just in front of the structure. If seaward of a surf zone *Goda* (1985) recommends for practical design a value of $1.8 H_s$ to be used corresponding to the 0.15% exceedence value for Rayleigh distributed wave heights. This corresponds to $H_{1/250}$ (mean of the heights of the waves included in 1/250 of the total number of waves, counted in descending order of height from the highest wave). *Goda's* recommendation includes a safety factor in terms of positive bias. If within the surf zone, the design wave height is taken as the highest of the random breaking waves at a distance $5 H_s$ seaward of the structure.

2.2.2 Takahashi et al. (1994)

Takahashi et al. (1994) is a *Goda* formula modified to include impulsive forces from head-on breaking waves. developed an extension to the *Goda* method to include the effect of breaking wave impacts. This modification was obtained by re-analysing the results of comprehensive model tests of caissons slid-

ing under wave impacts, together with analysis of the breakwater movements at Sakata Port, Japan 1973-74. The modification is applied to the Goda method by changing the formulation for the α_2 coefficient. Takahashi introduces a new coefficient which is the maximum of α_2 or a new impulsive coefficient α_1 , itself given by two coefficients representing the effect of wave height on the mound, and mound shape.

2.2.3 Tanimoto & Kimura (1985)

The most used method for pressure distribution on inclined wall is from *Tanimoto & Kimura (1985)*. The Authors performed model tests and demonstrated that the Goda formula (1975) can be applied by projection of the Goda wave pressures calculated for a vertical wall with the same height (crest level) as illustrated in the Figure 5. The Tanimoto & Kimura formula is valid for $\alpha \geq 70^\circ$ and $l_d < 0.1 L$, where L is the wave length in front of the structure.

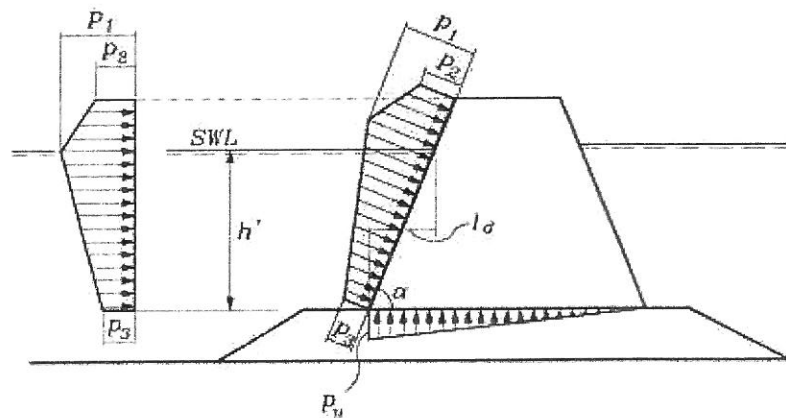

Figure 5. Pressure distribution on inclined wall after *Tanimoto & Kimura (1985)*.

2.2.4 Takahashi & Hosoyamada (1994)

The Authors developed corrections to Goda's p_1 , p_2 , p_3 to account for a structure with a sloped portion beginning just below the waterline (Fig. 6).

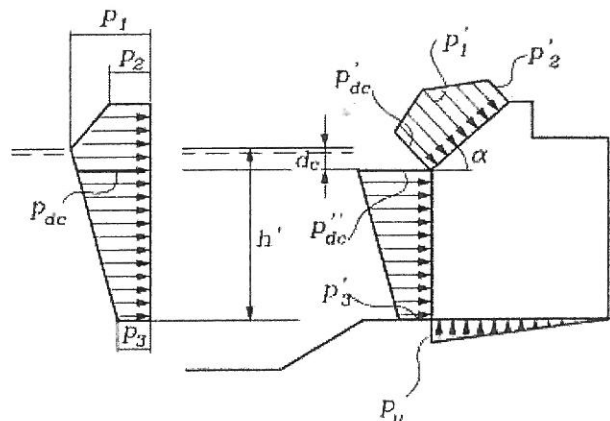

Figure 6. Pressure distribution on sloping top structures after *Takahashi & Hosoyamada (1994)*.

3 Laboratory study

Model tests have been performed in a wave tank at Aalborg University, in 1:60 length scale compared to the prototype. This wave basin is a steel bar reinforced concrete tank with the dimensions 15.7 x 8.5 x 1.5 m. The paddle system is a snake-front piston type with a total of ten actuators, enabling generation of short-crested waves. The waves are absorbed by a rubble beach slope in the back of the basin to minimize reflection (Fig. 7).

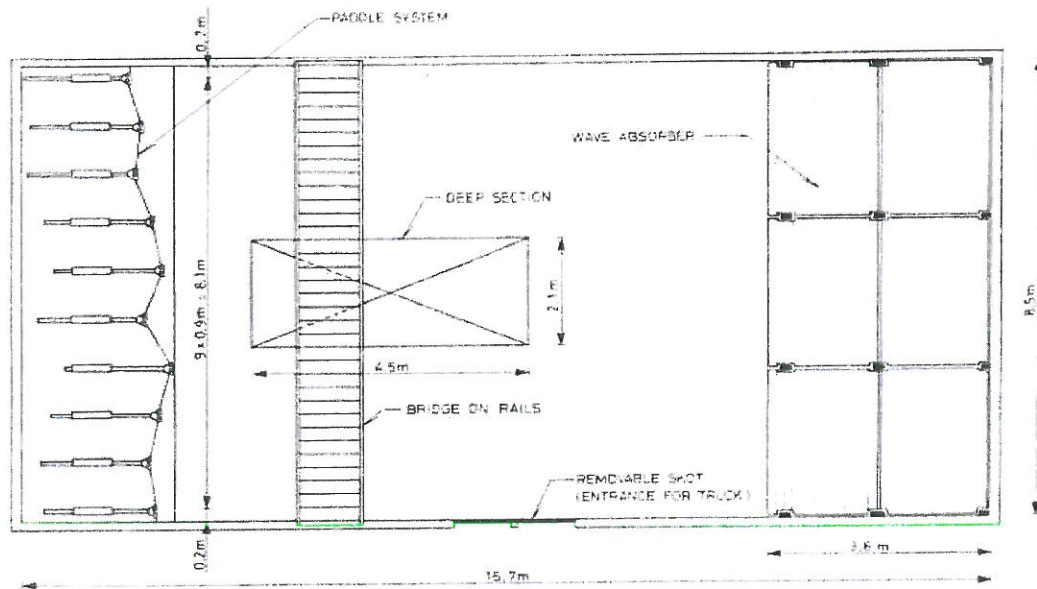

Figure 7. Scheme of the deep 3-D wave basin.

The wave generation software used for controlling the wave paddles is AWASYSS5, developed by the laboratory research staff. The bathymetry in the immediate proximity of the pilot plant has been surveyed and the results have been used as the basis for the laboratory model. The SSG caisson model was built in plexiglass with dimension of 0.471 x 0.179 m. The three front plates were positioned with a slope of $\alpha = 35^\circ$. The model was installed on a 3D concrete model of the cliff located in the middle of the basin at 5 m from the paddles. Seven resistive wave probes were located on a pentangle array placed on the plateau. Fourteen Kulite Semiconductor pressure cells were used to measure the pressure in a total of 25 positions on the structure plates (Fig. 8). Two different transducer configurations were needed because of the very limited space inside the model combined with the physical dimensions of the pressure transducers (Fig. 9).

Table 1 shows the JONSWAP sea states selected for the tests. Each test comprised approximately 1000 waves. Tests were carried out with frontal and oblique waves (45° , denoted "Side" in Tab. 1), with various levels of directional spreading (n). Due to the extension of test setup, the oblique wave attack was realized by turning the complete model in the basin. The experimental procedure has been designed to ensure that data are available to allow a good estimation of the surface loads corresponding to the design 100 years return period wave event at the plateau, given by wave condition $H_s = 12.5$ m and $T_p = 15.2$ s corresponding to test 3 in Table 1. Not only the 100 years return period wave event were simulated in order to allow comparisons between laboratory data and field measured from the pilot plant once built. The wave signals were stored and reused from transducer configuration number one to configuration number two. Each of the 32 tests was thereby performed twice.

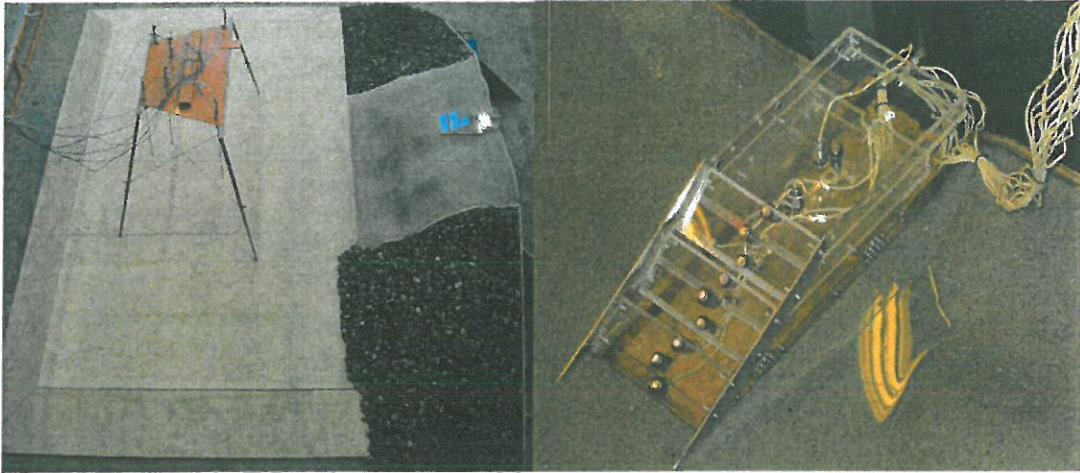

Figure 8. Bathymetry and model set up.

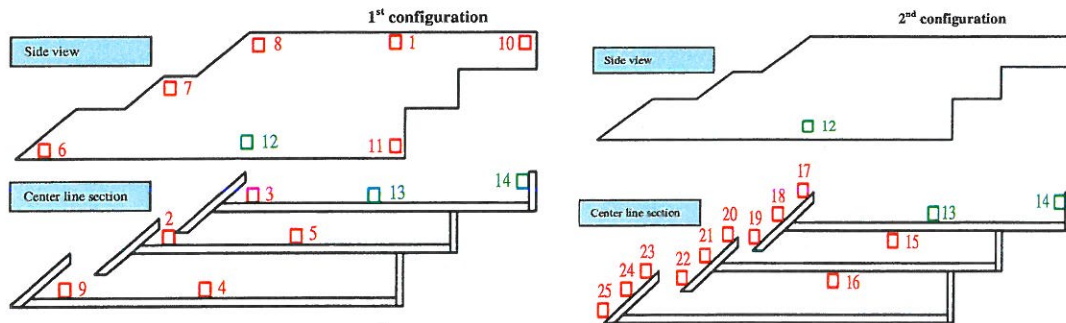

Figure 9. Tests configurations and pressure cells locations.

Test	H_s [m]	T_p [s]	swl [m]	Direction	Wave field	Test	H_s [m]	T_p [s]	swl [m]	Direction	Wave field	n
1	0.125	1.55	0.50	Front	2D	17	0.125	1.55	0.53	Front	3D	4
2	0.167	1.81	0.50	Front	2D	18	0.167	1.81	0.53	Front	3D	4
3	0.208	1.94	0.50	Front	2D	19	0.208	1.94	0.53	Front	3D	4
4	0.250	2.07	0.50	Front	2D	20	0.250	2.07	0.53	Front	3D	4
5	0.042	1.03	0.50	Side	2D	21	0.042	1.03	0.53	Side	3D	4
6	0.083	1.29	0.50	Side	2D	22	0.083	1.29	0.53	Side	3D	4
7	0.125	1.55	0.50	Side	2D	23	0.125	1.55	0.53	Side	3D	4
8	0.167	1.81	0.50	Side	2D	24	0.167	1.81	0.53	Side	3D	4
9	0.125	1.55	0.53	Front	2D	25	0.125	1.55	0.53	Front	3D	10
10	0.167	1.81	0.53	Front	2D	26	0.167	1.81	0.53	Front	3D	10
11	0.208	1.94	0.53	Front	2D	27	0.208	1.94	0.53	Front	3D	10
12	0.250	2.07	0.53	Front	2D	28	0.250	2.07	0.53	Front	3D	10
13	0.042	1.03	0.53	Side	2D	29	0.042	1.03	0.53	Side	3D	10
14	0.083	1.29	0.53	Side	2D	30	0.083	1.29	0.53	Side	3D	10
15	0.125	1.55	0.53	Side	2D	31	0.125	1.55	0.53	Side	3D	10
16	0.167	1.81	0.53	Side	2D	32	0.167	1.81	0.53	Side	3D	10

Table 1. Summary of model wave conditions.

A preliminary visual test analysis (Fig. 10) permitted to identify two different behaviours of waves acting on the structure:

- surging waves, characterized by a rapid rise of the wave along the three sloping front caisson plates – no breaking waves;
- impact of water jet, resulting from massive wave overtopping directly hitting the vertical rear wall in upper reservoir, characterized by evident wave slamming.

Because of this different wave-structure interactions two different pressure sampling rate were set up. Each test was run twice. On the first run pressure data were acquired at a rate of 200 Hz. A second run was carried out at sampling rate of 1200 Hz.

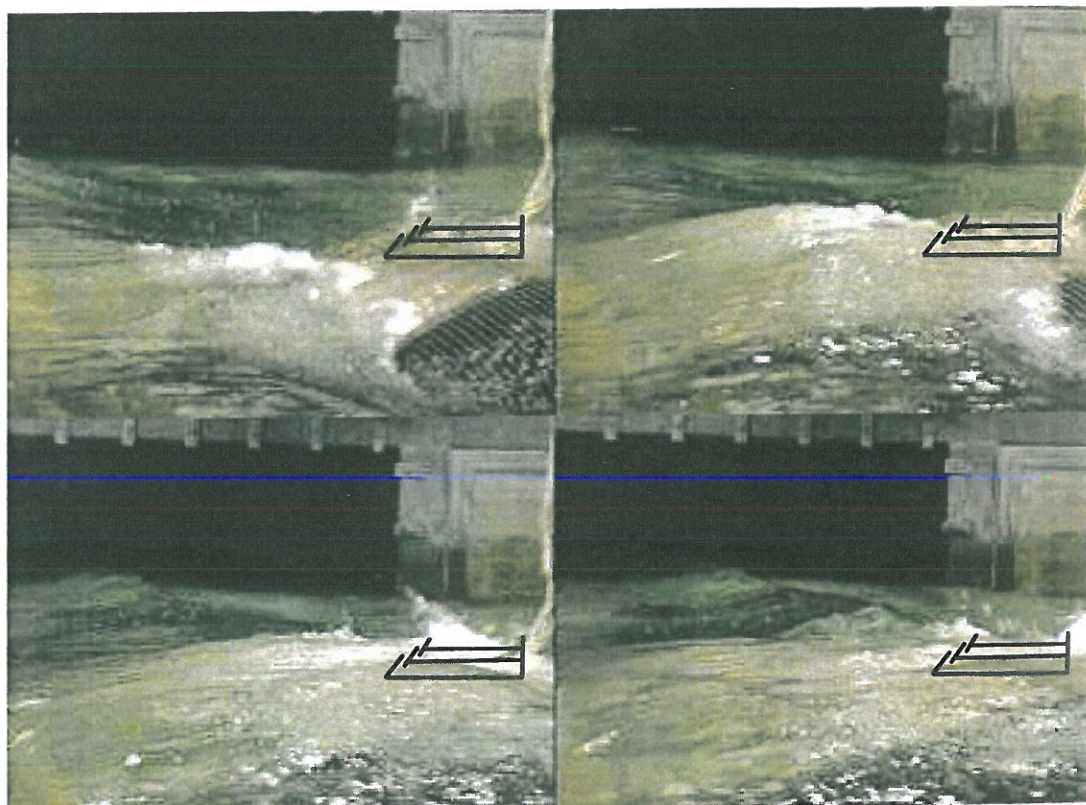

Figure 10. Sequence of video frames from test 4 (time between frames: 0.2 s).

4 Results

Results discussed here derive from preliminary analysis conducted using tests 1, 2, 3, 4 (Tab. 1), expected to represent the most severe wave loading.

4.1 Loading regimes

The first part of the experimental data analysis was finalized to identify the loading regime on different structure locations. In Figure 11 an example of 9 second pressure time history recorded by transducers mounted on the front sloping walls and on the rear wall under the extreme wave attack is shown (Test 4). It should be noted that the generated wave pressures do not vary substantially from one plate to another. Thus, a quasi-static loading time history is recognizable. A completely different behaviour was recog-

nized from time history analysis of the pressure transducer at the rear wall in the upper reservoir. Comparison with front plate transducer signal show evident rapidly-varying in time and high pressure peaks typically described as “impact”. This pressure example exhibits a relative small impact pressure due to the damped breaking waves. To confirm this behaviour, for the same test, a comparison was made between pressure signal acquired at 200 Hz and at 1200 Hz. In Figure 12 is reported as example different time histories for tdx. 21 (front plate) and for tdx. 14 (rear wall). Multiple tests at different rate show from one side the repeatability of the events in time and pressure, but on the other, the extreme impulsive variability of the peaks on the rear wall not recognizable at the slow acquisition rate.

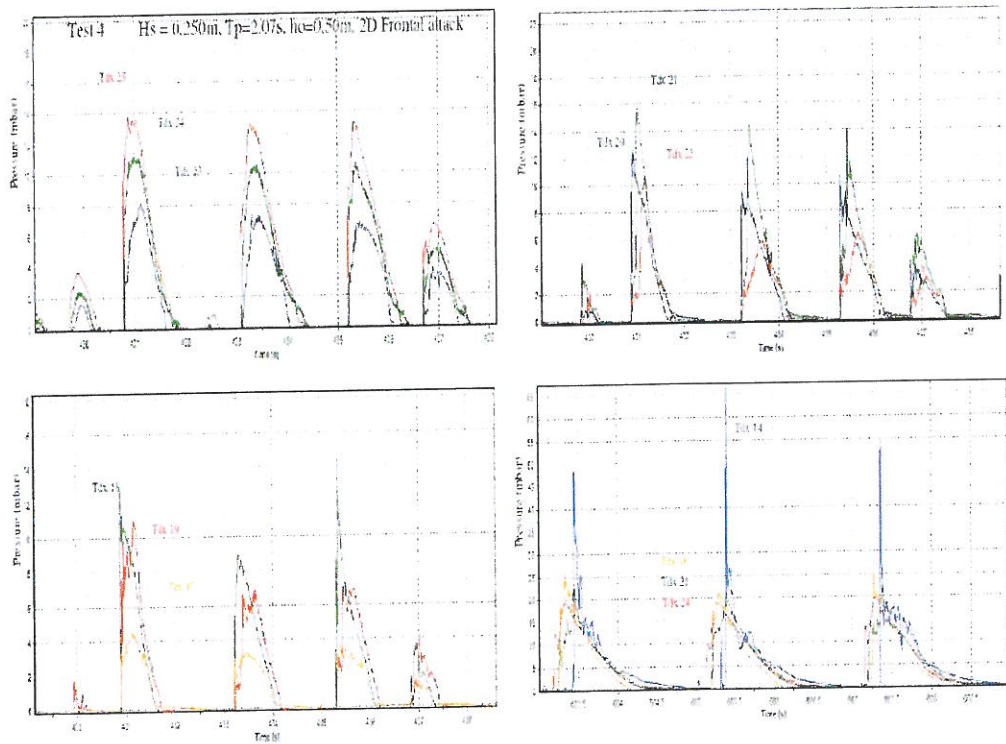

Figure 11. Pressure time history at the transducers on the front plates and on the rear wall.

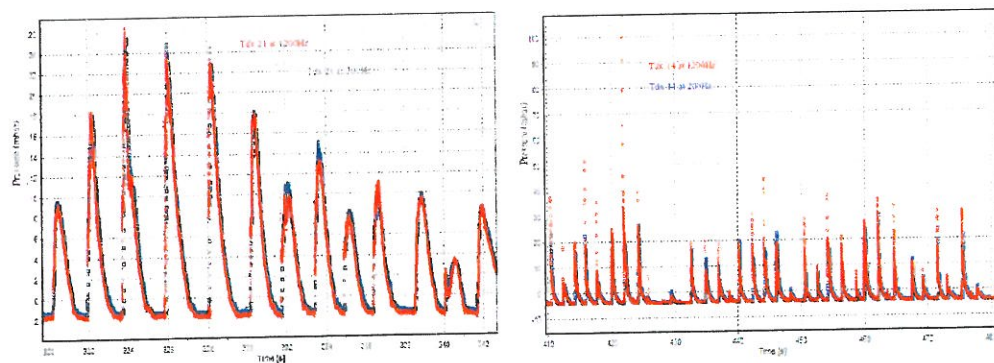

Figure 12. Pressure time history acquired at 200 Hz and at 1200 Hz for tdx. 21 and 14.

The multiple tests at different rate permitted the level of repeatability of the events within the tests to be verified: the mean of the four largest events (pressure 1/250) identified from the pressure measurements for the first run were observed in the second runs as almost the same (pulsating, quasi-static event) as shown in Figures 13 (36.66 mbar against 36.94 mbar). The exceedance level probability plot show the high discrepancy of values for the different acquisition rates for “impact” events. The difference within the tests is illustrated in Figures 14 (57.60 mbar against 97.37 mbar). All the analysis is following use data acquired at 200 Hz with the exception of tdx. 14 where 1200 Hz acquired data are employed.

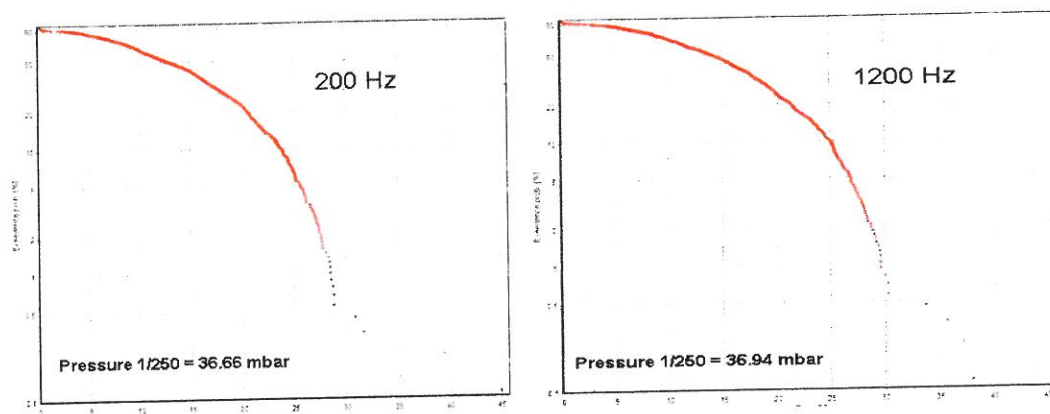

Figure 13. Comparison between transducers on the front plates and on the rear wall.

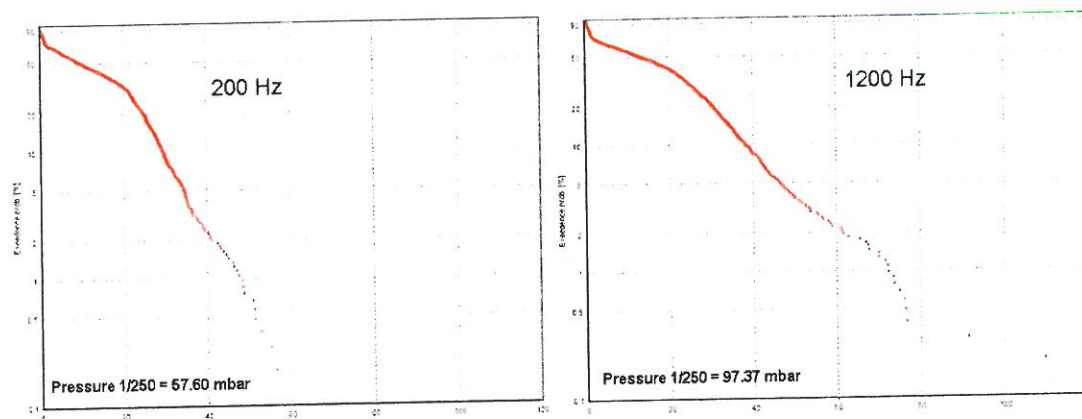

Figure 14. Comparison between transducers on the front plates and on the rear wall.

4.2 Statistical loading distribution

A statistical distribution of the pressures is needed in order to allow for a choice of exceedance or non exceedance values for the relative design loading. The values derived from statistical distribution can be used for all deterministic or probabilistic calculations of structures where loading pulsating or impact waves are considered. The only distribution model that has been derived mathematically on the basis of the physical process governing the wave height is Rayleigh distribution which is a special case of Weibull. In the present analysis a Weibull distribution is proposed. The distribution can be written in its standard form as follows:

$$F = F_x(x) = P(X < x) = 1 - e^{-\left(\frac{x-B}{A}\right)^k} \quad (1)$$

where X is a characteristic wave pressure depending on the extreme data set, x is a realization of X , F is the non-exceedance probability of x (cumulative frequency) and A , B , k are the distribution parameters to be fitted. Partial series data sets composed of the largest pressure values in each individual test exceeding a certain level (threshold, x') have been selected. The pressure threshold is determined based on the Authors engineering experience. All the peaks below this threshold are not considered for the fitting of the distribution. For the following analysis the maximum likelihood method was used to fit the distribution parameters. The Weibull distribution is rewritten to allow an easy pressure extrapolation for a chosen exceedance probability level:

$$x = A \cdot \left(-\ln(1 - F^*)\right)^{\frac{1}{k}} + B \quad (2)$$

$$F^* = 1 - \frac{n}{N} \cdot (1 - F) \quad (3)$$

where F is the non exceedance pressure/force, n is the total number of peaks selected above the threshold and N is the total number of peaks in the selected test. For a more general interpretation all the results in the following section are non-dimensionalised as $p/\rho_w g H_s$. Kolmogorov-Smirnov test was applied to verify the fit goodness of the probability distribution.

The exceedance level probability plot and Weibull plot are also reported for test 14 and 21 (Fig. 15 and 16) to highlight the high diversity of values for the different acquisition rates for "impact" events (rear wall).

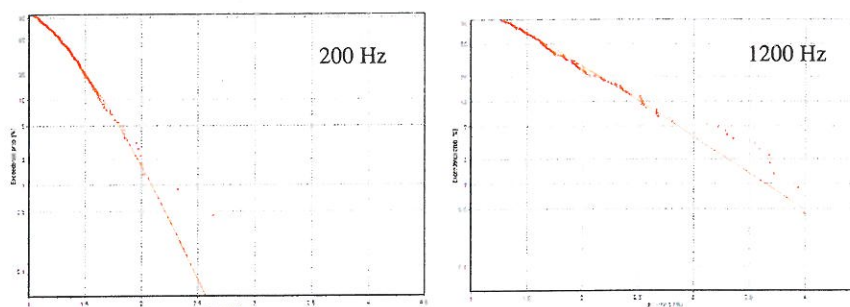

Figure 15. Exceedance probabilities of $p/\rho_w g H_s$ at transducer 14 – test 3.

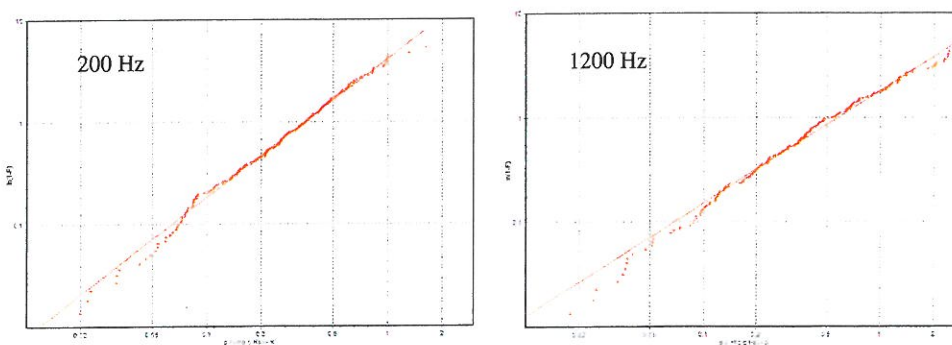

Figure 16. Weibull plot for transducer 14 – test 3 (at 200 Hz and 1200 Hz).

In Table 20 and 21, are reported results for the rear wall at two different acquisition sample rates (200 Hz and 1200 Hz). The effect of spreading is also shown reporting results for tests 19 and 27 (Tables 17, 18, 19).

Plate number 1																		
Acquisition channel number																		
15						14						9						
Transducer positions																		
25						24						23						
Weibull parameters																		
Test	A	B	k	n	N	nN	A	B	k	n	N	nN	A	B	k	n	N	nN
1	0.147	0.720	1.191	235	1191	0.20	0.152	0.614	1.235	237	1159	0.20	0.101	0.412	1.139	237	1191	0.20
2	0.172	0.756	1.138	207	1026	0.20	0.158	0.660	1.150	196	1005	0.20	0.130	0.449	1.115	207	1031	0.20
3	0.200	0.755	1.672	191	979	0.20	0.201	0.626	1.742	191	960	0.20	0.150	0.478	1.295	191	948	0.20
4	0.148	0.755	1.428	184	926	0.20	0.144	0.658	1.542	180	921	0.20	0.099	0.490	1.276	172	870	0.20

Table 2. Summary of Weibull distribution parameters for plate 1.

Plate number 2																		
Acquisition channel number																		
11						13						6						
Transducer positions																		
22						21						20						
Weibull parameters																		
Test	A	B	k	n	N	nN	A	B	k	n	N	nN	A	B	k	n	N	nN
1	0.127	0.498	1.327	234	1164	0.20	0.198	0.755	1.189	247	1260	0.20	0.185	0.482	1.137	263	1308	0.20
2	0.131	0.492	1.161	197	995	0.20	0.240	0.770	1.252	216	1072	0.20	0.208	0.550	1.200	225	1111	0.20
3	0.107	0.482	1.191	178	908	0.20	0.240	0.812	1.476	197	988	0.20	0.236	0.568	1.603	204	1031	0.20
4	0.088	0.455	1.338	170	851	0.20	0.191	0.810	1.488	177	898	0.20	0.205	0.579	1.554	198	985	0.20

Table 3. Summary of Weibull distribution parameters for plate 2.

Plate number 3																		
Acquisition channel number																		
12						3						7						
Transducer positions																		
19						18						17						
Weibull parameters																		
Test	A	B	k	n	N	nN	A	B	k	n	N	nN	A	B	k	n	N	nN
1	0.177	0.401	1.149	247	1227	0.20	0.190	0.441	1.244	281	1399	0.20	0.089	0.146	0.980	255	1271	0.20
2	0.227	0.470	1.074	204	1015	0.20	0.299	0.520	1.124	256	1184	0.20	0.114	0.195	0.903	222	1084	0.20
3	0.306	0.528	1.780	185	917	0.20	0.335	0.524	1.592	224	1095	0.20	0.190	0.238	1.459	209	1022	0.20
4	0.214	0.587	1.592	170	851	0.20	0.276	0.628	1.230	202	1022	0.20	0.179	0.301	1.334	190	953	0.20

Table 4. Summary of Weibull distribution parameters for plate 3.

Plate number 9						
Acquisition channel number						
4						
Transducer positions						
14						
Weibull parameters						
Test	A	B	k	n	N	nN
1	0.71593	0.52451	1.02600	268	1347	0.20
2	0.80314	0.93884	1.46060	238	1215	0.20
3	0.57537	1.26570	1.07390	225	1095	0.20
4	0.52641	1.21950	1.02440	202	1016	0.20

Table 5. Summary of Weibull distribution parameters for plate 9.

4.3 Spatial distribution of wave pressures

The major emphasis in any study on wave loadings is on the overall or average level of pressures, which is needed to determine the overall stability of the structure. Data on local pressures and pressure gradients are also needed in any analysis of conditions leading to local damage. The results summarized in Table 6 appear to indicate that pressures on front plates are quasi static ($p_{1/250} \sim \rho_w g H_{max}$) or pulsating loads generated by non-breaking waves. The wave loading on the rear vertical wall are varying over 2 - 3 $\rho_w g H_{max}$. In this case the wave is collapsing in the upper reservoir in front of the wall. This loading case exhibits a relative small impact pressure due to the damped breaking waves.

Plate	Sampling rate(Hz)	Tdx	1	2	3	4
			$p_{1/250}(\text{kN/m}^2)$	$p_{1/250}(\text{kN/m}^2)$	$p_{1/250}(\text{kN/m}^2)$	$p_{1/250}(\text{kN/m}^2)$
9	1200	14	5.16	5.51	7.84	9.74
3	200	17	0.86	1.37	1.48	2.15
	200	18	1.47	2.60	3.02	4.19
	200	19	1.44	2.30	2.44	2.90
2	200	20	1.49	2.08	2.37	3.03
	200	21	1.87	2.70	2.92	3.67
	200	22	1.12	1.55	1.65	1.89
1	200	23	1.05	1.56	2.31	2.53
	200	24	1.40	2.07	2.28	2.83
	200	25	1.61	2.43	2.49	3.31

Table 6. Summary of model tests pressure 1/250.

The analysis of these pressure measurements made at laboratory scale using fresh water has explicitly assumed a Froude scale conversion to prototype values. In the case of pulsating wave pressures the assumption of Froude scaling is realistic while for wave impact pressure scaling is less simple. It has long been argued in the EU project on caisson breakwaters, PROVERBS (Oumeraci et al., 1999), that wave impact in small scale hydraulic model tests will be greater in magnitude, but shorter in duration than their equivalents at full scale in (invariably aerated) sea water. It is very probable that the higher peak pressures measured in these model tests can be scaled to lower values, but probably each will attend by longer impulse durations. The argument on scaling these peak pressures requires information not presently available on the relationships between the statistics of the pressure time gradients and the magnitude of the pressure impulses. It can be argued that the magnitude of the pressure impulse, given perhaps by $(p \Delta t)$ will not be changed between model and prototype, other than by the normal scaling relationships. Measurements of wave pressures planned at pilot SSG in Kvitsoy will be useful to estimate model-prototype scaling discrepancies. In Table 7 the Froude scaled pressures value for the analyzed tests are reported.

Plate	Tdx	1	2	3	4
		$p_{1/250}(\text{kN/m}^2)$	$p_{1/250}(\text{kN/m}^2)$	$p_{1/250}(\text{kN/m}^2)$	$p_{1/250}(\text{kN/m}^2)$
9	14	309	330	470	584
3	17	51	82	89	129
	18	88	156	181	251
	19	87	138	146	174
2	20	89	125	142	182
	21	112	162	175	220
	22	67	93	99	113
1	23	63	93	139	152
	24	84	124	137	170
	25	97	146	149	199

Table 7. Summary of pressure 1/250 scaled to prototype.

4.4 Comparison with design methods

This methods are not directly applicable to the tested structure but they are the engineering tools that better describe in literature the phenomena. The reason to compare measurements against these prediction methods was to check the order of magnitude of tests results.

Comparison for the extreme wave condition tested (test 4) are reported in Table 8. Tanimoto & Kimura (1985) and Takahashi & Hosoyamada (1994) prediction give the same values and the overall agreement is, despite the violation of the formulas presumptions, quite good. Predicted values are, averaging each plate values, about 10% greater then the measured ones. Pressure gradients are greater in model than predicted by formulas.

Plate	Tdx	Test 4	see Fig. 19 and Fig. 20	Tanimoto and Kimura (1985)	Takahashi and Hosoyamada (1994)
		$p_{1/250}$ (kN/m ²)		$p_{1/250}$ (kN/m ²)	$p_{1/250}$ (kN/m ²)
3	17	129	p_2	175	175
	18	251	p_1	202	202
	19	174	p_3	202	203
2	20	182	p_2	186	186
	21	220	p_1	202	202
	22	113	p_3	200	198
1	23	152	p_2	194	194
	24	170	p_1	202	202
	25	199	p_3	200	195

Table 8. Summary of predicted pressure 1/250.

CONCLUSIONS

A new type of concrete caisson breakwater is employed as wave energy converted based on the known principle of overtopping and storing the wave energy in reservoirs above sea level. SSG has been model tested for the first time at the Aalborg University with the main aim to give advice to the structure designers on wave loading acting on different parts of the structure. Mainly two different behaviours were identified: surging waves on the front sloping plates and damped impact water jet on the vertical rear wall in upper reservoir. The order of magnitude of the extreme peak pressure on the front plates scaled to prototype were 250 kN/m² that are comparable with the one predicted by Tanimoto and Kimura (1985) for inclined impermeable walls. The pressure 1/250 corresponds to non-exceedance levels of about 99.7%. For a more conservative design a different non-exceedance levels could be chosen and the corresponding pressure can be calculated using the Weibull distribution with the appropriate parameters from Tables 3, 4, 5, 6. On the vertical rear wall in the upper reservoir impact pressures (very peaked, short duration) of up to 580 kN/m² were registered. In order to avoid such loading on the structure vertical walls parallel to attack wave crest should be avoided. Anyway the final design of the pilot caisson should include a monitored central vertical area to record pressure impact in order to evaluate scale effects.

Acknowledgements. The work discussed here is part of the European Union Sixth Framework programme priority 6.1 (Sustainable Energy System), contract 019831, titled "Full-scale demonstration of robust and high-efficiency wave energy converter" (WAVESSG). Substantial financial support has been given by the Co-operation Agreement between WAVEenergy AS (Norway) and Department of Civil Engineering - Aalborg University. The first Author gratefully acknowledge the Department of Civil Engineering of Aalborg University and of Second University of Naples for encouraging mobility of researchers.

REFERENCES

- Allsop, N.W.H., D. Vicinanza & J.E. McKenna, (1996), "Wave Forces On Vertical And Composite Breakwaters", Strategic Research Report, Hydraulic Research Wallingford, Sr 443, Wallingford.
- Calabrese, M., Vicinanza, D. (1999), "Prediction of wave impact occurrence on vertical and composite breakwaters", Excerpta of the Italian contributions to the field of hydraulic engineering, Vol.XIII, 25pp., ISSN 0394-526X.
- Coastal Engineering Manual (2002), U.S. Army Corps of Engineers. 2002. Engineer Manual 1110-2-1100, U.S. Army Corps of Engineers, Washington, D.C. (in 6 volumes).
- Goda, Y. (1974). "New Wave Pressure Formulae for Composite Breakwaters," Proceedings of the 14th International Coastal Engineering Conference, Vol 3, pp 1702-1720.
- Goda, Y. (1985), Random Seas and Design of Maritime Structures, University of Tokyo Press, Tokyo, Japan.
- Kofoed, J. P. (2005), "Model testing of the wave energy converter Seawave Slot-Cone Generator", Hydraulics and Coastal Engineering No. 18, ISSN: 1603-9874, Dept. of Civil Eng., Aalborg University.
- Kofoed, J. P. (2006), "Experimental Hydraulic Optimization the Wave Energy Converter Seawave Slot-Cone Generator", Hydraulics and Coastal Engineering No. 26, ISSN: 1603-9874, Dept. of Civil Eng., Aalborg University.
- Kofoed, J. P. (2006), "Vertical Distribution of Wave Overtopping for Design of Multi Level Overtopping Based Wave Energy Converters", 30th International Conference on Coastal Engineering, San Diego.
- Kofoed, J. P. and Osaland E. (2005), "Crest level optimization of the multi level reservoir overtopping based wave energy converter Seawave Slot-cone Generator, 6th European Wave & Tidal Conference, Glasgow.
- Kortenhaus, A., & A. Löffler, (1998), Differences in estimating probability of impacts. Status Report 2nd Overall Project Workshop MAST III (PROVERBS). Naples.
- Kortenhaus, A., and Oumeraci, H. (1998), "Classification of Wave Loading on Monolithic Coastal Structures," Proceedings of the 26th International Coastal Engineering Conference, Vol 1, pp 867-880.
- Larsen, B. J. and Kofoed, J. P. (2005), "Model Test Setup and Program for Experimental Estimation of Surface Loads of the SSG Kvitsøy Pilot Plant from Extreme Wave Conditions", Hydraulics and Coastal Engineering No. 32, ISSN: 1603-9874, Dep. of Civil Eng., Aalborg University.
- Takahashi, S., and Hosoyamada, S. (1994), "Hydrodynamic Characteristics of Sloping Top Caissons," Proceedings of International Conference on Hydro-Technical Engineering for Port and Harbour Construction, Port and Harbour Research Institute, Japan, Vol 1, pp 733-746.
- Takahashi, S., Tanimoto, K., and Shimosako, K. (1994), "A Proposal of Impulsive Pressure Coefficient for Design of Composite Breakwaters," Proceedings of the International Conference on Hydro-Technical Engineering for Port and Harbor Construction, Port and Harbour Research Institute, Yokosuka, Japan, pp 489-504.
- Tanimoto, K., and Kimura, K. (1985), "A Hydraulic Experimental Study on Trapezoidal Caisson Breakwaters," Technical Note No. 528, Port and Harbour Research Institute, Yokosuka, Japan (in Japanese).
- Tanimoto, K., Takahashi, K., and Kitatani, T. (1981), "Experiment Study of Impact Breaking Wave Forces on a Vertical Wall Caisson of Composite Breakwater," Report of Port and Harbour Research Institute, Vol 20, No. 2, pp 3-39 (in Japanese).
- Thorpe, T.W., (1999), "An Overview of Wave Energy Technologies: Status, Performance and Costs", "Wave Power - Moving Towards Commercial Viability", IMECHE Seminar, London, UK.
- Vicinanza, D. (1997a), "Probabilistic analysis of horizontal wave forces on composite and vertical breakwaters", 2nd PROVERBS MAST III technical workshop, Las Palmas.
- Vicinanza, D. (1997b), "Pressioni e forze di impatto di onde frangenti su dighe a paramento verticale e composte", PhD. thesis, University of Naples, Italy.
- Istruzioni Tecniche per la progettazione delle Dighe Marittime, pubblicate dal Consiglio Superiore LLPP e dal CNR - GNDCI (pubbl. n.1450/96).