



Aalborg Universitet

AALBORG UNIVERSITY  
DENMARK

## Day-ahead Energy Management for Hybrid Electric Vessel with Different PEM Fuel Cell Modular Configurations

Xie, Peilin; Asgharian, Hossein; Vasquez, Juan C.; Guerrero, Josep M.; Simon Araya, Samuel; Liso, Vincenzo

*Published in:*  
Energy Reports

*DOI (link to publication from Publisher):*  
[10.1016/j.egy.2022.12.091](https://doi.org/10.1016/j.egy.2022.12.091)

*Creative Commons License*  
CC BY-NC-ND 4.0

*Publication date:*  
2023

*Document Version*  
Publisher's PDF, also known as Version of record

[Link to publication from Aalborg University](#)

*Citation for published version (APA):*

Xie, P., Asgharian, H., Vasquez, J. C., Guerrero, J. M., Simon Araya, S., & Liso, V. (2023). Day-ahead Energy Management for Hybrid Electric Vessel with Different PEM Fuel Cell Modular Configurations. *Energy Reports*, 9(Supplement 3), 99-106. <https://doi.org/10.1016/j.egy.2022.12.091>

### General rights

Copyright and moral rights for the publications made accessible in the public portal are retained by the authors and/or other copyright owners and it is a condition of accessing publications that users recognise and abide by the legal requirements associated with these rights.

- Users may download and print one copy of any publication from the public portal for the purpose of private study or research.
- You may not further distribute the material or use it for any profit-making activity or commercial gain
- You may freely distribute the URL identifying the publication in the public portal -

### Take down policy

If you believe that this document breaches copyright please contact us at [vbn@aub.aau.dk](mailto:vbn@aub.aau.dk) providing details, and we will remove access to the work immediately and investigate your claim.



2022 3rd International Conference on Power, Energy and Electrical Engineering (PEEE 2022)  
18–20 November 2022

# Day-ahead energy management for hybrid electric vessel with different PEM fuel cell modular configurations

Peilin Xie, Hossein Asgharian, Juan C. Vasquez, Josep Guerrero, Samuel Simon Araya, Vincenzo Liso\*

*Energy AAU - Aalborg University, Aalborg, Denmark*

Received 15 December 2022; accepted 27 December 2022  
Available online 3 January 2023

## Abstract

The increasing demand for decarbonization of marine transportation motivates the utilization of low-carbon resources. Among different options, fuel cells are drawing attention. The selection of fuel cell (FC) and the design of energy management strategy would have a great impact on the vessel's operational efficiency, and thereby needs to be considered carefully. The objective of this paper is to develop energy management system (EMS) to reduce the fuel consumption of a hybrid fuel cell/battery ship. To this end, a day-ahead EMS scheme is proposed that takes full use of information including ship cruising routines and the degradation status of the fuel cell modules. The developed EMS is optimization-based and conducted off-line to provide guideline for the next-day power generation plan. In addition, three power allocating strategies across the multiple fuel cell modules are considered and compared (equal, independent, and sequential). A sequential rotation procedure is proposed to reduce the degradation rates of the fuel cell modules. Simulation results show that the proposed EMS can effectively improve the fuel economy of the hybrid ship while enhancing sufficient energy backup throughout the full voyage. In addition, comparisons between different FC configurations implies that the independent distribution has the highest fuel efficiency, and with the proposed rotation procedure, the sequential distribution can effectively improve the fuel efficiency by up to 23.2%.

© 2022 Published by Elsevier Ltd. This is an open access article under the CC BY-NC-ND license (<http://creativecommons.org/licenses/by-nc-nd/4.0/>).

Peer-review under responsibility of the scientific committee of the 3rd International Conference on Power, Energy and Electrical Engineering, PEEE, 2022.

**Keywords:** PEM fuel cells; Modularity; Marine applications; Liquid hydrogen; Energy management system; Optimization

## 1. Introduction

As a critical part of the global economy, shipping is by far the most environmentally friendly mode, accounting for only 11% of the global CO<sub>2</sub> emissions yet undertaking 80% of the world's trade [1]. However, the International Maritime Organization (IMO) has taken further action to pursue the decarbonization of marine transportation. Currently, traditional fossil fuels are still the primary source for more than 95% of ships [2,3]. With advantages in

\* Corresponding author.

*E-mail address:* [vl@energy.aau.dk](mailto:vl@energy.aau.dk) (V. Liso).

<https://doi.org/10.1016/j.egy.2022.12.091>

2352-4847/© 2022 Published by Elsevier Ltd. This is an open access article under the CC BY-NC-ND license (<http://creativecommons.org/licenses/by-nc-nd/4.0/>).

Peer-review under responsibility of the scientific committee of the 3rd International Conference on Power, Energy and Electrical Engineering, PEEE, 2022.

zero pollutant emissions, high efficiency, and low operating temperatures, polymer electrolyte membrane (PEM) fuel cells (FC) are a strong candidate for future maritime applications and has gained wide attention to build zero-emission ships.

Due to the slow dynamic response of fuel cells, an auxiliary power supply, usually a battery, is recommended to cooperate with fuel cell to satisfy the highly dynamic navigation scenarios [4]. To ensure the operational efficiency, economy, and long lifetime of onboard facilities, an EMS is a tool that has been widely studied. Existing EMS research for hybrid fuel cell/battery ships has mainly focused on three areas: optimal facility sizing [5–8], early-stage energy generation planning, and real-time power allocation [9–12]. Due to the direct impacts of the energy generation plans on the decisions of weight, size, and lifetime of the onboard energy facilities, the first two targets are usually coupled and thus forming a joint problem. Solving these problems requires a good pre-knowledge of the historical load profile, but it contributes to reduced occupied space, economic costs, and fuel consumption.

Most of the previous work neglects the configuration and degradation status of the fuel cells and gives energy dispatching plans based on the assumption that the vessel has a particular and unchangeable cruising route and timetable without effectiveness validation when the situation changes. Considering that adjustments in ship sailing patterns and harbor conditions would have directly impacts on the propulsion loads and cold-ironing supplements, and that different FC configurations and degradation levels affect the FC characteristics, customized energy dispatching plans are essential in improving the vessel operational reliability and efficiency.

To address these issues, a hybrid FC/battery passenger vessel with one-day routine is studied. The main target of this paper is to propose a day-ahead EMS to enable more fuel-efficiency operation with considerations of ship’s voyage plan, and FC modular status. The contributions of the paper are summarized as follows:

1. Customize the day-ahead power generation plans based on next-day sailing plans: routine, time schedule, ports cold-ironing information, sailing speed, etc.
2. Customize the day-ahead power generation plans based on FC degradation status.
3. Customize the day-ahead power generation plans for three different FC configurations: independent, equal, and sequential.
4. Reduce the degradation rate of the FC by developing rotational mode.

## 2. Problem description and PEM modeling

### 2.1. Vessel information

The studied vessel is a tour ferry, transferring travelers for one-day tour journal. An example of the daily ship routine and load profile is presented as Fig. 1. Detailed information are related to [11]. The onboard loads contain two parts: propulsion load and service load. The general structure of the electrical power system is as Fig. 2. As seen, fuel cells are the major power supplier, and the battery provides auxiliary support. The ferry is supported by fuel cell and batteries while on sail and has the possibility to get access to cold ironing while arriving at the harbor.

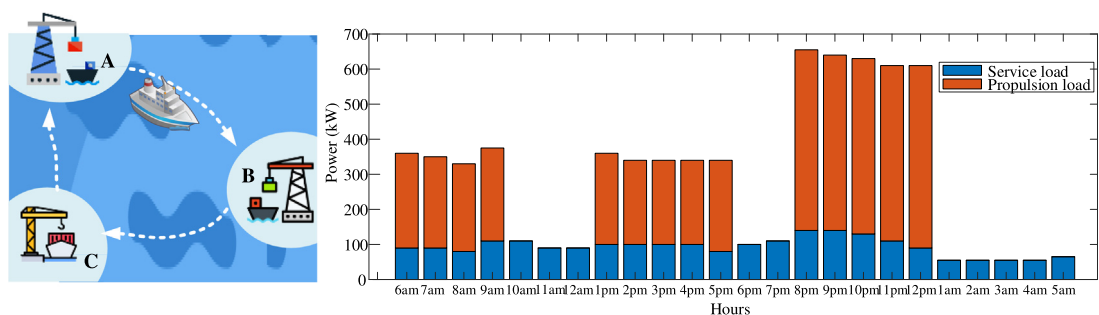

Fig. 1. (a) vessel routine example; (b) onboard loads for one day.

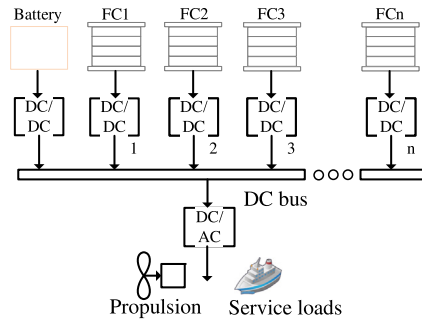

Fig. 2. Ship power train based on a modular FC/ battery hybrid system.

2.2. Fuel cell

In this part, the pressure drop in gas channels of the PEM fuel cell stacks along with the compressor power consumption to compensate for the pressure drop are investigated. Furthermore, the effect of degradation on the performance of the utilized PEM fuel cell is also evaluated.

According to the literature, the pressure drop in the anode side is much lower than the cathode side [13,14]. Furthermore, in the most cases, pressurized hydrogen stored in a tank is used in the anode side. Therefore, compressing H<sub>2</sub> before entering the anode is not always necessary. Hence, in this study the pressure drop in the cathode side is considered and calculated using the following equation:

$$\Delta P = \int_0^L \frac{f\rho}{2d} V^2 dx + \sum_1^i k \frac{\rho}{2} V^2 \tag{1}$$

where the first term on the right side represents the major pressure losses, while the second term represents the minor losses. In this equation  $f$ ,  $\rho$ ,  $L$ ,  $k$ ,  $d$ ,  $i$ , and  $V$  represent friction coefficient, air density, channel length, minor loss coefficient, channel hydraulic diameter, number of swerve corners in gas channels, and the gas flow speed.

To consider the effect of degradation on the performance of the fuel cell stack, the degradation rates given by Chen et al. [15] for different operating condition modes were considered. In this case, the voltage of the fuel cell which is affected by the degradation can be calculated as follows:

$$V = V_0 - (V'_1 \times n_1 + U'_1 \times t_1 + V'_2 \times n_2 + U'_2 \times t_2) \tag{2}$$

where  $V_0$  stands for voltage at the fuel cell initial state, while  $V'_1$ ,  $U'_1$ ,  $V'_2$ , and  $U'_2$  denote voltage degradation rates for start–stop cycles, idling period, load change cycle, and high-power load period, respectively. In Eq. (2),  $n_1$ ,  $t_1$ ,  $n_2$ , and  $t_2$  also represent the number of cycles for start–stop, the period of idling, number of load change cycles, and the period of high-power load, respectively.

To save the computational efforts, FC performance is described in a lookup table based on the up-mentioned mathematic modeling. Fitted curves are also shown in Fig. 3. Results under different degradation status are presented including undegraded (BoL), after 10k hours of operation, after 20k hours of operation, and after 30k hours of operation. As Fig. 3 indicates, the degradation causes reduced efficiency, and the fitted curves present high accuracy.

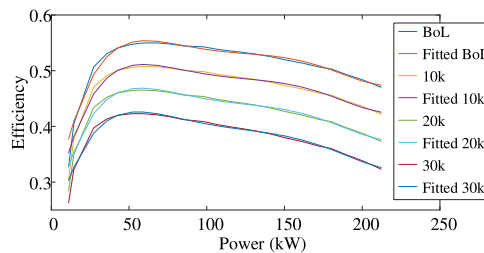

Fig. 3. Fuel cell module efficiency curves under different operational time.

### 3. Energy management system designing

The electrical parameters of each onboard energy equipment is shown in Table 1. A general view of the proposed EMS is illustrated in Fig. 4. The EMS is developed based on optimization algorithm. By gathering the information of day-ahead cruising plans, cold-ironing accessibility, and FC degradation status, the off-line optimization decides the on/off status of FCs and optimizes the power sharing. In addition, the power generation plans are developed for the three different FC configurations individually.

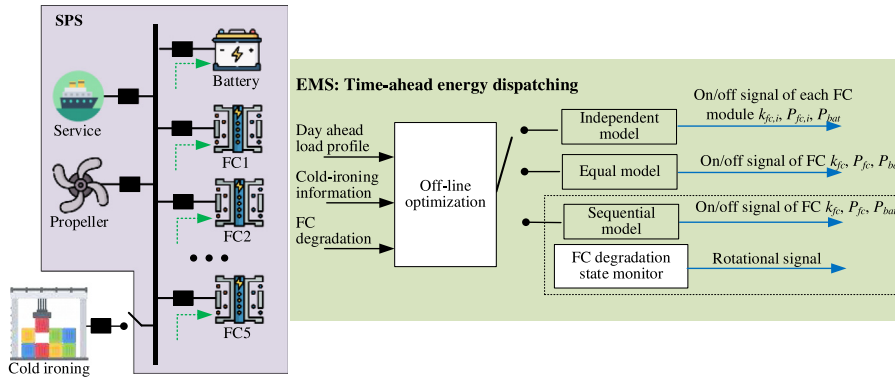

Fig. 4. Overall structure of the proposed EMS.

Table 1. Electrical parameters of each onboard energy equipment.

Equipment	Parameters	Values	Parameters	Values
Fuel cells	Maximum output power $P_{fc(max)}$	200 kW	Quantities $N_{fc}$	5
	Minimum output power $P_{fc(min)}$	15 kW	–	–
Battery	Capacity $Q_b$	25 kWh	Voltage $V_{oc}$	125 V
	SOC range	0.3, 0.95	Initial SOC	0.6
	Maximum discharging power	20 kW	Quantities $N_{bat}$	20
	Maximum charging power	15 kW	–	–

#### 3.1. Optimization problem formulation

The objective of the offline optimization is to minimize the overall fuel consumption during one-day cruise. Thus, the cost function is as follows.

$$\min J = \sum_{t=1}^{24} \sum_{i=1}^{N_{fc}} k_{fc,i,t} * P_{fc,i,t} / \eta_{fc,i,t} \tag{3}$$

where  $N_{fc}$  is the quantities of the FC and is set as 5.  $k_{fc,i,t}$  is the on/off status of  $i$ th fuel cell at time  $t$ .  $P_{fc,i,t}$  is the output power of it, and  $\eta_{fc,i,t}$  is the efficiency. The cost function is subject to the following constraints depending on the cruising conditions: on sail or at port. To ensure that the ship has enough reserving energy, it is set that the SOC of the battery at the 24th hour should be greater than 0.6. Thus, the constraints are expressed as follows:

$$\text{on sail} \left\{ \begin{array}{l} \sum_{i=1}^{N_{fc}} k_{fc,i,t} P_{fc,i,t} + P_{bat,t} = P_{load,t} \\ k_{fc,i,t} \in \{0, 1\} \\ P_{fc,i,t} \in [P_{fc(min)}, P_{fc(max)}] \\ P_{bat,t} \in [P_{bat(min)}, P_{bat(max)}] \\ SOC_{bat,t} \in [SOC_{bat(min)}, SOC_{bat(max)}] \\ P_{cold-ironing,t} = 0 \end{array} \right. \tag{4}$$

$$\text{at port} \left\{ \begin{array}{l} \sum_{i=1}^{N_{fc}} k_{fc,i,t} P_{fc,i,t} + P_{bat,t} + P_{cold-ironing,t} = P_{load,t} \\ k_{fc,i,t} \in \{0, 1\} \\ P_{fc,i,t} \in [P_{fc(min)}, P_{fc(max)}] \\ P_{bat,t} \in [P_{bat(min)}, P_{bat(max)}] \\ SOC_{bat,t} \in [SOC_{bat(min)}, SOC_{bat(max)}] \\ SOC_{bat,24} \geq 0.6 \end{array} \right. \quad (5)$$

where the first equality constraint ensures the power balance. The second binary constraint represents the on/off status of FC. The inequality constraints govern the output power limits of FC, output power limits of battery, and SOC limits respectively. In addition, there are additional constraints for FCs in different configurations. For equal distribution, the power demand is equally allocated to each module, thus the on/off status and reference power of each FC is equal. As shown below,

$$\left\{ \begin{array}{l} k_{fc,i,t} = k_{fc,j,t} \quad \forall i, j \in \mathbb{N}_{fc} \\ P_{fc,i,t} = P_{fc,j,t} \quad \forall i, j \in \mathbb{N}_{fc} \end{array} \right. \quad (6)$$

For independent distribution, the power demand for each FC module is optimized by the EMS. Thus there is no extra constraints. For sequential distribution, the power demand is allocated to one module only if the former one reached to its maximum output power. Thus the additional constrains can be expressed as,

$$k_{fc,i+1,t} = \text{not} (P_{fc,i,t} k_{fc,i,t} - P_{fc(max)}) \quad (7)$$

### 3.2. FC degradation monitor and sequence rotation

As it has been discussed in Section 2, the degradation rate of FC is highly affected by its operational time and the uneven usage of FCs is the main reason for their different degradation rates. The difference in FC degradation levels would be more severe in sequential distribution since the first FC is the most frequently used. To guarantee a similar degradation rate for all FCs, a sequence rotation procedure is developed by monitoring the degradation status of each FC and rearranging the sequence of them. In this way, all FCs would have similar speeds of degradation rate.

## 4. Case study

In this paper, the effectiveness of the proposed EMS is tested under four FC configurations (equal, independent, sequential, and rotational sequential), three different cruises (Cruise 1, Cruise 2, and Cruise 3), and five degradation levels (as in Table 2). The performance of the EMS is evaluated in terms of power sharing performance, SOC status, and fuel consumption. Rule-based method in Ref. [16] is adopted to benchmark the fuel saving capability. The proposed EMS is built in GAMS and solved by BONMINH.

**Table 2.** Case description: different FC degradation status. (BoL: Beginning-of-Life, 10k: after 10k hours usage, 20k: after 10k hours usage, 30k: after 10k hours usage).

	FC1	FC2	FC3	FC4	FC5
Case 1	BoL	BoL	BoL	BoL	BoL
Case 2	10k	BoL	BoL	BoL	BoL
Case 3	20k	10k	BoL	BoL	BoL
Case 4	30k	20k	10k	BoL	BoL
Case 5	30k	20k	10k	10k	BoL

### 4.1. Optimization results under Cruise 1, Cruise 2, and Cruise 3

In Cruise 1, The ferry leaves port A at 6:00 am and arrives at port B at 9:00 am. After 3 h docking, the ferry leaves port B at 13:00 pm and arrives at port C at 17:00 pm. Afterwards, it depatures for port A at 20:00 pm and

arrives at 00:00. During its berth in each port, the vessel gets access to the cold ironing. The load profile is the same as presented in Fig. 1. The power sharing and SOC performance of the system is shown in Fig. 5. And the fuel consumption results are shown in Table 3.

**Table 3.** Fuel consumption performance in Cruise 1 (Most and least efficient configurations are highlighted in green and red).

EMS	FC configurations	Case1	Case 2	Case 3	Case 4	Case 5
Proposed	Equal	3.6312e7	3.6946e7	3.8344e7	4.0671e7	4.1306e7
	Independent	3.6298e7	3.6610e7	3.7354e7	3.8612e7	3.9582e7
	Sequential	4.0072e7	4.2332e7	4.6709e7	5.2307e7	5.2307e7
	Rotational sequential	4.0072e7	4.0072e7	4.0072e7	4.0493e7	4.1788e7
Rule-based	Equal	3.7354e7	3.8015e7	3.9467e7	4.1887e7	4.2547e7
	Sequential	4.0944e7	4.3104e7	4.7302e7	5.3353e7	5.3407e7
	Rotational sequential	4.0944e7	4.0944e7	4.0999e7	4.1713e7	4.3185e7

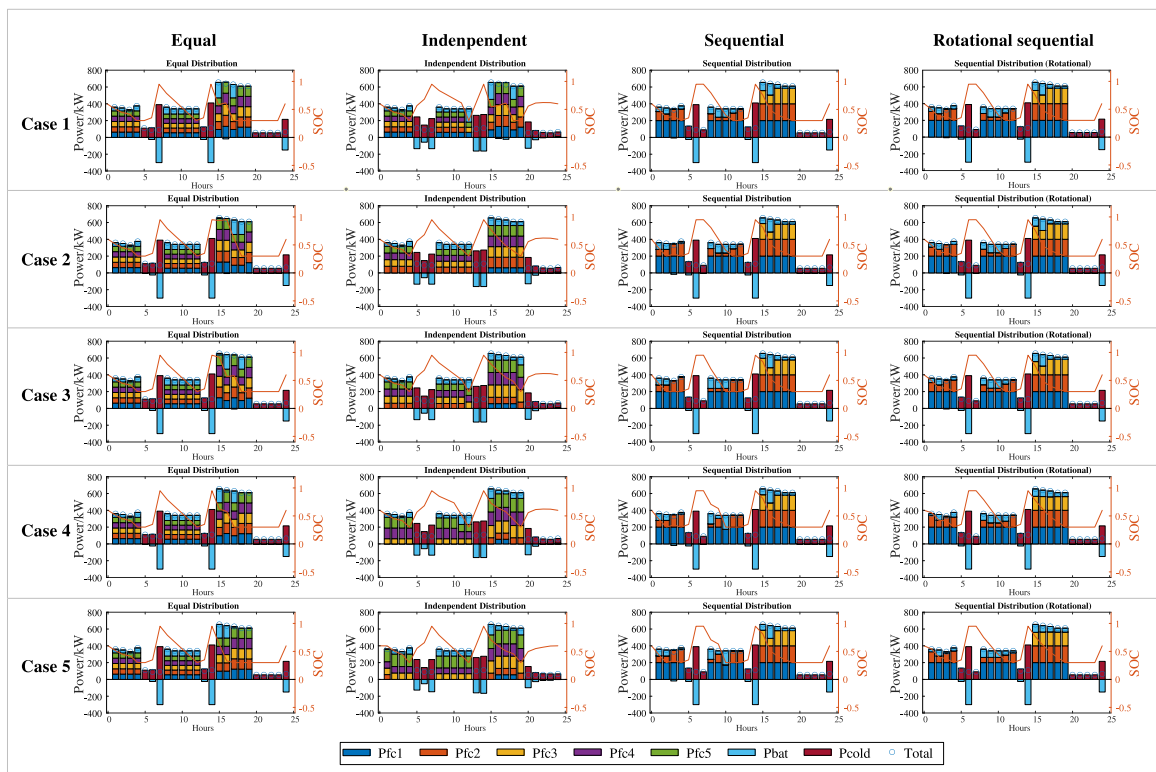

**Fig. 5.** System performance in Cruise 1.

In Cruise 2, the ship follows the same routine, except that it will not get access to the cold ironing in port C due to maintenance from 17.00–20:00. The corresponding fuel consumption results are shown in Table 4.

In cruise 3, the ship travels only between port A and port C, as can be found in Fig. 6. It leaves port A at 9:00 am. After 5 h full speed sailing, it arrives at port C at 13:00 pm and stays for 6 h. It departs at 20:00 pm and arrives back at port A at 00:00. The corresponding fuel consumption results are shown in Table 5.

#### 4.2. Remarks

According to the case study results, following remarks can be drawn:

**Table 4.** Fuel consumption performance in Cruise 2 (Most and least efficient configurations are highlighted in green and red).

EMS	FC configurations	Case1	Case 2	Case 3	Case 4	Case 5
Proposed	Equal	3.9780e7	4.0477e7	4.2009e7	4.4547e7	4.5240e7
	Independent	3.9775e7	4.0092e7	4.0896e7	4.2238e7	4.3290e7
	Sequential	4.4225e7	4.6757e7	5.1564e7	5.8047e7	5.8047e7
	Rotational sequential	4.4225e7	4.4225e7	4.4225e7	4.4598e7	4.6065e7
Rule-based	Equal	4.1778e7	4.2519e7	4.4151e7	4.6874e7	4.7615e7
	Sequential	4.5322e7	4.7609e7	5.2093e7	5.8665e7	5.9750e7
	Rotational sequential	4.5322e7	4.5322e7	4.5406e7	4.6319e7	4.7924e7

**Table 5.** Fuel consumption performance in Cruise 3 (Most and least efficient configurations are highlighted in green and red).

EMS	FC configurations	Case1	Case 2	Case 3	Case 4	Case 5
Proposed	Equal	3.7231e7	3.7911e7	3.9417e7	4.1928e7	4.2607e7
	Independent	3.7231e7	3.7629e7	3.8429e7	4.0038e7	4.1073e7
	Sequential	4.0530e7	4.2132e7	4.6091e7	5.1553e7	5.1553e7
	Rotational sequential	4.0530e7	4.0530e7	4.0530e7	4.1547e7	4.3159e7
Rule-based	Equal	3.9032e7	3.9756e7	4.1357e7	4.4045e7	4.4769e7
	Sequential	4.3071e7	4.4699e7	4.8238e7	5.4258e7	5.4359e7
	Rotational sequential	4.3071e7	4.3071e7	4.3171e7	4.4739e7	4.6219e7

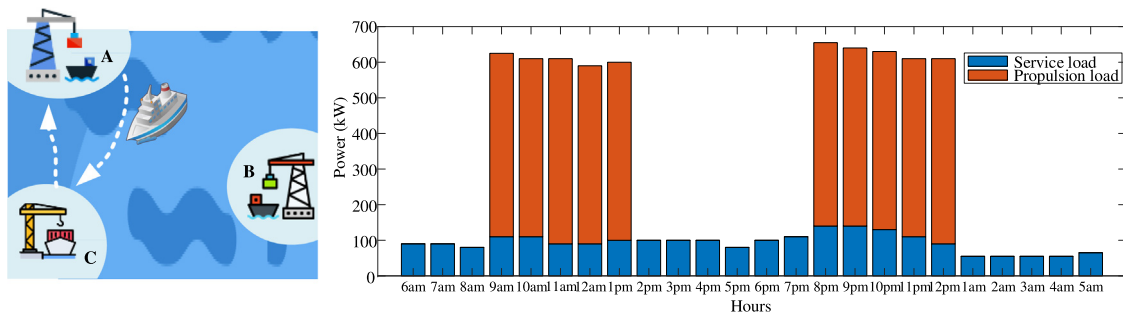

**Fig. 6.** (a) vessel routine: Cruise 3; (b) onboard loads for one day.

- FC supports the major load when the ship is at sea and the batteries provide auxiliaries. When the ship arrives at the ports, the shore-side cold ironing power supports the service load and charge the batteries.
- The more the fuel cell degrades, the more fuel it consumes.
- The battery SOC remains healthy (30%–95%) during the cruising, and at a high level (>60%) at the end of the voyage, thus providing promising energy reservation.
- Among the three FC distributions, the independent distribution consumes the least amount of fuel by distributing power to the less degraded modules. The sequential distribution consumes the most fuel. However, sequential distribution with rotation can improve the fuel economy by up to 23.2%.
- Traditional rule-based method gives only the total power reference for the five FC modules without considering the power distribution way among them, while the proposed optimization-based EMS can optimize the power sharing between multiple FC modules according to their power configurations. Up to 7.13% improvement in fuel savings can be achieved at the same FC distribution by adopting the proposed EMS. And that value raises to 28% when compared to the independent distribution.



## 5. Conclusion

This paper presents an optimization-based energy management system for hybrid FC/battery passenger ships. The proposed EMS has high robustness and remains effective under multiple cases. The effectiveness of the proposed EMS is validated through comparisons with the traditional rule-based method. Comprehensive case studies valid that the proposed EMS can enable more efficient operations by customizing the next-day power generation plans according to the future shipping cruise, shore-side information, FC degradation status, and FCs electrical distributions. Among all FC distribution, the independent distribution achieves the best fuel efficiencies in all cases, and the sequential distribution with the proposed rotation procedure largely improves the fuel efficiency.

However, considering that the onboard load can be highly variable and fluctuating due to changeable sea and sailing conditions, a real-time power management system (PMS) is essential to execute the decision from day-ahead EMS while satisfying instantaneous load demand. In future work, we will develop a two-stage EMS that addresses both issues to ensure high efficiency of the ship under real-time operations.

## Declaration of competing interest

The authors declare that they have no known competing financial interests or personal relationships that could have appeared to influence the work reported in this paper.

## Data availability

No data was used for the research described in the article.

## Acknowledgments

We would like to acknowledge the project LH2Vessel (EUDP, Denmark J.Nr. 64019-0023) and the project VILLUM Investigator, Denmark (Grant 25920) for sponsoring this research.

## References

- [1] Xie P, Guerrero JM, Tan S, Bazmohammadi N, Vasquez JC, Mehrzadi M, et al. Optimization-based power and energy management system in shipboard microgrid: A review. *IEEE Syst J* 2022;16:578–90.
- [2] Xie P, Tan S, Bazmohammadi N, Guerrero JM, Vasquez JC. A real-time power management strategy for hybrid electrical ships under highly fluctuated propulsion loads. *IEEE Syst J* 2022;1–12.
- [3] Xie P, Tan S, Bazmohammadi N, Guerrero JM, Vasquez JC, Alcalá JM, et al. A distributed real-time power management scheme for shipboard zonal multi-microgrid system. *Appl Energy* 2022;317:119072.
- [4] Tan S, Wu Y, Xie P, Guerrero JM, Vasquez JC, Abusorrah A. New challenges in the design of microgrid systems: Communication networks, cyberattacks, and resilience. *IEEE Electr Mag* 2020;8:98–106.
- [5] Chen H, Zhang Z, Guan C, Gao H. Optimization of sizing and frequency control in battery/supercapacitor hybrid energy storage system for fuel cell ship. *Energy* 2020;117285.
- [6] Kistner L, Bensmann A, Hanke-Rauschenbach R. Optimal design of power gradient limited solid oxide fuel cell systems with hybrid storage support for ship applications. *Energy Convers Manage* 2021;243:114396.
- [7] Zhang Z, Guan C, Liu Z. Real-time optimization energy management strategy for fuel cell hybrid ships considering power sources degradation. *IEEE Access* 2020;8:87046–59.
- [8] Letafat A, Rafiei M, Sheikh M, Afshari-Igder M, Banaei M, Boudjadar J, et al. Simultaneous energy management and optimal components sizing of a zero-emission ferry boat. *J Energy Storage* 2020;28:101215.
- [9] Xie P, Tan S, Guerrero JM, Vasquez JC. MPC-informed ECMS based real-time power management strategy for hybrid electric ship. *Energy Rep* 2021;7:126–33.
- [10] Bassam AM, Phillips AB, Turnock SR, Wilson PA. Development of a multi-scheme energy management strategy for a hybrid fuel cell driven passenger ship. *Int J Hydrog Energy* 2017;42:623–35.
- [11] Rafiei M, Boudjadar J, Khooban M-H. Energy management of a zero-emission ferry boat with a fuel-cell-based hybrid energy system: Feasibility assessment. *IEEE Trans Ind Electron* 2021;68:1739–48.
- [12] Gaber M, El-Banna SH, El-Dabah M, Hamad MS. Intelligent energy management system for an all-electric ship based on adaptive neuro-fuzzy inference system. *Energy Rep* 2021;7:7989–98.
- [13] Dutta S, Shimpalee S, Van Zee JW. Numerical prediction of mass-exchange between cathode and anode channels in a PEM fuel cell. *Int J Heat Mass Transf* 2001;44:2029–42.
- [14] Liso V, Nielsen MP, Kær SK, Mortensen HH. Thermal modeling and temperature control of a PEM fuel cell system for forklift applications. *Int J Hydrog Energy* 2014;39:8410–20.
- [15] Chen H, Pei P, Song M. Lifetime prediction and the economic lifetime of proton exchange membrane fuel cells. *Appl Energy* 2015;142:154–63.
- [16] Han J, Charpentier J-F, Tang T. An energy management system of a fuel cell/battery hybrid boat. *Energies* 2014;7:2799–820.