

## Reliability of capacitors for DC-link applications - An overview

Wang, Huai; Blaabjerg, Frede

*Published in:*

2013 IEEE Energy Conversion Congress and Exposition (ECCE 2013)

*DOI (link to publication from Publisher):*

[10.1109/ECCE.2013.6646935](https://doi.org/10.1109/ECCE.2013.6646935)

*Publication date:*

2013

*Document Version*

Early version, also known as pre-print

[Link to publication from Aalborg University](#)

*Citation for published version (APA):*

Wang, H., & Blaabjerg, F. (2013). Reliability of capacitors for DC-link applications - An overview. In *2013 IEEE Energy Conversion Congress and Exposition (ECCE 2013)* (pp. 1866-1873). IEEE Press.  
<https://doi.org/10.1109/ECCE.2013.6646935>

### General rights

Copyright and moral rights for the publications made accessible in the public portal are retained by the authors and/or other copyright owners and it is a condition of accessing publications that users recognise and abide by the legal requirements associated with these rights.

- Users may download and print one copy of any publication from the public portal for the purpose of private study or research.
- You may not further distribute the material or use it for any profit-making activity or commercial gain
- You may freely distribute the URL identifying the publication in the public portal -

### Take down policy

If you believe that this document breaches copyright please contact us at [vbn@aub.aau.dk](mailto:vbn@aub.aau.dk) providing details, and we will remove access to the work immediately and investigate your claim.

© 2013 IEEE. Personal use of this material is permitted. Permission from IEEE must be obtained for all other uses, in any current or future media, including reprinting/republishing this material for advertising or promotional purposes, creating new collective works, for resale or redistribution to servers or lists, or reuse of any copyrighted component of this work in other works.

Digital Object Identifier (DOI): (to be appear)

Proceedings of the IEEE Energy Conversion Congress and Exposition (ECCE 2013), Denver, CO, USA, 14-19 September, 2013.

### **Reliability of Capacitors for DC-Link Applications – An Overview**

Huai Wang  
Frede Blaabjerg

#### **Suggested Citation**

H. Wang and F. Blaabjerg, "Reliability of capacitors for DC-link applications – An overview," *in Proc. IEEE Energy Convers. Congr. and Expo.*, 2013, pp. 1866-1873.

# Reliability of Capacitors for DC-Link Applications – An Overview

Huai Wang, *IEEE Member*, Frede Blaabjerg, *IEEE Fellow*

Center of Reliable Power Electronics (CORPE), Department of Energy Technology  
Aalborg University  
Pontoppidanstraede 101, DK-9220 Aalborg, Denmark  
hwa@et.aau.dk; fbl@et.aau.dk

**Abstract**— DC-link capacitors are an important part in the majority of power electronic converters which contribute to cost, size and failure rate on a considerable scale. From capacitor users' viewpoint, this paper presents a review on the improvement of reliability of DC-link in power electronic converters from two aspects: 1) reliability-oriented DC-link design solutions; 2) conditioning monitoring of DC-link capacitors during operation. Failure mechanisms, failure modes and lifetime models of capacitors suitable for the applications are also discussed as a basis to understand the physics-of-failure. This review serves to provide a clear picture of the state-of-the-art research in this area and to identify the corresponding challenges and future research directions for capacitors and their DC-link applications.

## I. INTRODUCTION

DC-link capacitors are widely used in power converters to balance the instantaneous power difference between the input source and output load, and minimize voltage variation in the DC link. In some applications, they are also used to provide sufficient energy during the hold-up time. Fig. 1 shows the typical configurations of power electronic conversion systems with DC-link capacitors. Such configurations cover a wide range of power electronics applications, such as in wind turbines, photovoltaic systems, motor drives, electric vehicles and lighting systems. With more stringent reliability constraints brought by automotive, aerospace and energy industries, the design of DC links encounters the following challenges: a) capacitors are one kind of the stand-out components in terms of failure rate in field operation of power electronic systems [1]-[2]; b) cost reduction pressure from global competition dictates minimum design margin of capacitors without undue risk; c) capacitors are to be exposed to more harsh environments (e.g. high ambient temperature, high humidity, etc.) in emerging applications and d) constraints on volume and thermal dissipation of capacitors with the trends for high power density power electronic systems [3].

The efforts to overcome the above challenges can be divided into three categories: a) advance the capacitor technology with improved and pre-determined reliability built in, b) optimal DC-link design solutions based on the present

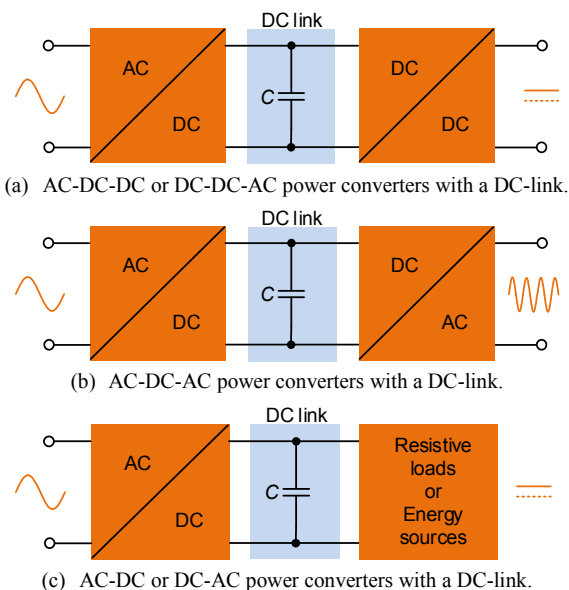

Fig. 1. Typical configurations of power electronic conversion systems with DC-link capacitors.

capacitors to achieve proper robustness margin and cost-effectiveness, and c) implementations of condition monitoring to ensure reliable field operation and preventive maintenance. By taking the advantage of the progress in new dielectric materials and innovative manufacturing process, leading capacitor manufacturers have been continuously releasing new generations of products with improved reliability and cost performance. The proper application of these capacitors for specific DC-link design is equally important as the operating conditions (e.g. temperature, humidity, ripple current, voltage) could significantly influence the reliability of the capacitors. Compared to the first category, the latter two are more relevant from the power electronic designers' perspective, which therefore will be reviewed in this paper. Moreover, the comparison of capacitors suitable for DC-link applications are given. The failure modes, failure mechanisms, corresponding critical stressors and lifetime models of them are also mapped. The challenges and opportunities for future research directions are finally addressed.

## II. CAPACITORS FOR DC-LINK APPLICATIONS

Three types of capacitors are generally available for DC-link applications, which are the Aluminum Electrolytic Capacitors (Al-Caps), Metallized Polypropylene Film Capacitors (MPPF-Caps) and high capacitance Multi-Layer Ceramic Capacitors (MLC-Caps). The DC-link design requires the matching of available capacitor characteristics and parameters to the specific application needs under various environmental, electrical and mechanical stresses.

Fig. 2 shows a lumped model of capacitors.  $C$ ,  $R_s$  and  $L_s$  are the capacitance, Equivalent Series Resistance (ESR), Equivalent Series Inductance (ESL), respectively. The Dissipation Factor (DF) is  $\tan\delta = \omega R_s C$ .  $R_p$  is the insulation resistance.  $R_d$  is the dielectric loss due to dielectric absorption and molecular polarization and  $C_d$  is the inherent dielectric absorption [4]. The widely used simplified capacitor model is composed of  $C$ ,  $R_s$  and  $L_s$ . It should be noted that the values of them vary with temperature, voltage stress, frequency and time (i.e. operating conditions). The absence of the consideration into these variations may lead to improper analysis of the electrical stresses and thermal stresses, therefore, also many times unrealistic lifetime prediction.

The property of dielectric materials is a major factor that limits the performance of capacitors. Fig. 3 presents the relative permittivity (i.e. dielectric constant), continuous operational field strength and energy density limits of  $\text{Al}_2\text{O}_3$ , polypropylene and ceramics, which are the materials used in Al-Caps, MPPF-Caps and MLC-Caps, respectively [5]. It can be noted that  $\text{Al}_2\text{O}_3$  has the highest energy density due to high field strength and high relative permittivity. The theoretical limit is in the range of  $10 \text{ J/cm}^3$  and the commercial available one is about  $2 \text{ J/cm}^3$ . Ceramics could have much higher dielectric constant than  $\text{Al}_2\text{O}_3$  and film, however, it suffers from low field strength, resulting in similar energy density as that of film.

The three type of capacitors therefore exhibit specific advantages and shortcomings. Fig. 4 compares their performance from different aspects in a qualitative way. Al-Caps could achieve the highest energy density and lowest cost per Joule, however, with relatively high ESRs, low ripple current ratings, and wear out issue due to evaporation of electrolyte. MLC-Caps have smaller size, wider frequency range, and higher operating temperatures up to  $200^\circ\text{C}$ . However, they suffer from higher cost and mechanical sensitivity. The recent release of CeraLink series ceramic capacitors [6] is of interest to extend the scope of MLC-Caps for DC-link applications. It is based on a new ceramic materials of antiferroelectric behavior and strong positive bias effect (i.e. capacitance versus voltage stress). MPPF-Caps provide a well-balanced performance for high voltage applications (e.g. above  $500 \text{ V}$ ) in terms of cost and ESR, capacitance, ripple current and reliability. Nevertheless, they have the shortcomings of large volume and moderate upper operating temperature.

The DC-link applications can be classified into high

ripple current ones and low ripple current ones. The ripple current capability of the three types of capacitors is approximately proportional to their capacitance values as shown in Fig. 5.  $C_1$  is defined as the minimum required capacitance value to fulfill the voltage ripple specification. For low ripple current applications, capacitors with a total capacitance no less than  $C_1$  are to be selected by both Al-Caps solution and MPPF-Caps solution. For high ripple current applications, the Al-Caps with capacitance of  $C_1$  could not sustain the high ripple current stress due to low  $\text{A}/\mu\text{F}$ . Therefore, the required capacitance is increased to  $C_2$  by Al-Caps solution while the one by MPPF-Caps solution is  $C_1$ . In terms of ripple current (i.e.  $\$/\text{A}$ ), the cost of MPPF-Caps is about  $1/3$  of that of Al-Caps [7]. It implies the possibility to achieve a lower cost, higher power density DC-link design with MPPF-Caps in high ripple current applications, like the case in electric vehicles [8].

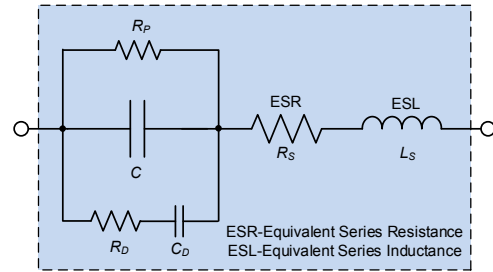

Fig. 2. A simplified lumped model of capacitors.

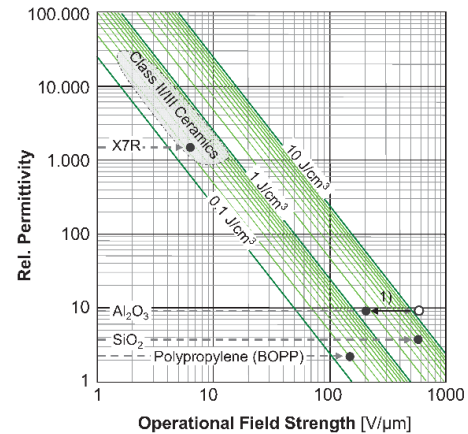

Fig. 3. Energy storage density for various dielectrics (BOPP: Biaxial Oriented Polypropylene, which is the preferred film material for capacitors rated above about  $250 \text{ V}$ ) [5].

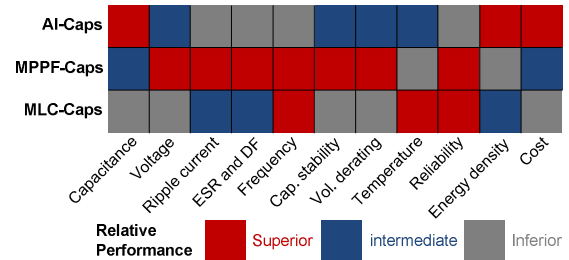

Fig. 4. Performance comparisons of the three main types of capacitors for DC-link applications.

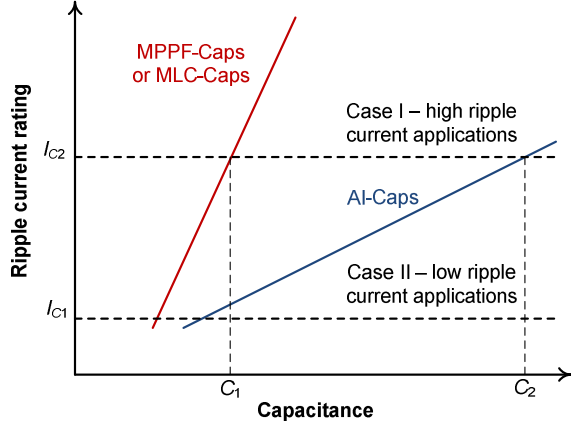

Fig. 5. Capacitance requirement of low ripple current applications and high ripple current applications.

### III. FAILURE AND LIFETIME OF DC-LINK CAPACITORS

#### A. Failure Modes, Failure Mechanisms and Critical Stressors

DC-link capacitors could fail due to intrinsic and extrinsic factors, such as design defect, material wear out, operating temperature, voltage, current, moisture and mechanical stress, and so on. Generally, the failure can be divided into catastrophic failure due to single-event overstress and wear out failure due to the long time degradation of capacitors. The major failure mechanisms have been presented in [9]-[12] for Al-Caps, [13]-[17] for MPPF-Caps and [18]-[20] for MLC-Caps. Based on these prior-art research results, Table I gives a systematical

summary of the failure modes, failure mechanisms and corresponding critical stressors of the three types of capacitors.

Table II shows the comparison of failure and self-healing capability of Al-Caps, MPPF-Caps and MLC-Caps. Electrolyte vaporization is the major wear out mechanism of small size Al-Caps (e.g. snap-in type) due to their relatively high ESR and limited heat dissipation surface. For large size Al-Caps, the wear out lifetime is dominantly determined by the increase of leakage current, which is relevant with the electrochemical reaction of oxide layer [21]. The most important reliability feature of MPPF-Caps is their self-healing capability [15]-[16]. Initial dielectric breakdowns (e.g. due to overvoltage) at local weak points of a MPPF-Cap will be cleared and the capacitor regains its full ability except for a negligible capacitance reduction. With the increase of these isolated weak points, the capacitance of the capacitor is gradually reduced to reach the end-of-life. The film layer in MPPF-Caps are in the order of 10-50 nm which are therefore susceptible to corrosion due to the ingress of atmospheric moisture. In [22], the corrosion mechanism is well studied. Figs. 6(a) and (b) shows the corrosion of the metallized layers of a degraded film capacitor located in the outer turns and inner turns of the capacitor roll, respectively. It reveals that severe corrosion occurs at the outer layers resulting in the separation of metal film from heavy edge and therefore the reduction of capacitance. The corrosion in the inner layers is less advanced as it is less open to the ingress of moisture. Unlike the dielectric materials of Al-Caps and MPPF-Caps,

TABLE I. OVERVIEW OF FAILURE MODES, CRITICAL FAILURE MECHANISMS AND CRITICAL STRESSORS OF THE THREE MAIN TYPES DC-LINK CAPACITORS (WITH EMPHASIS ON THE ONES RELEVANT TO DESIGN AND OPERATION OF POWER CONVERTERS).

Cap. type	Failure modes	Critical failure mechanisms	Critical stressors
Al-Caps	Open circuit	Self-healing dielectric breakdown	$V_C, T_a, i_C$
		Disconnection of terminals	Vibration
	Short circuit	Dielectric breakdown of oxide layer	$V_C, T_a, i_C$
		Electrolyte vaporization	$T_a, i_C$
MPPF-Caps	Open circuit (typical)	Electrochemical reaction (e.g. degradation of oxide layer, anode foil capacitance drop)	$V_C$
		Self-healing dielectric breakdown	$V_C, T_a, dV/dt$
		Connection instability by heat contraction of a dielectric film	$T_a, i_C$
	Short circuit (with resistance)	Reduction in electrode area caused by oxidation of evaporated metal due to moisture absorption	Humidity
Dielectric film breakdown		$V_C, dV/dt$	
MLC-Caps	Short circuit (typical)	Self-healing due to overcurrent	$T_a, i_C$
		Moisture absorption by film	Humidity
	Wear out: electrical parameter drift ( $C, ESR, \tan\delta, I_{LC}, R_p$ )	Dielectric loss	$V_C, T_a, i_C, \text{humidity}$
MLC-Caps	Short circuit (typical)	Dielectric breakdown	$V_C, T_a, i_C$
		Cracking; damage to capacitor body	Vibration
	Wear out: electrical parameter drift ( $C, ESR, \tan\delta, I_{LC}, R_p$ )	Oxide vacancy migration; dielectric puncture; insulation degradation; micro-crack within ceramic	$V_C, T_a, i_C, \text{vibration}$

$V_C$ -capacitor voltage stress,  $i_C$ -capacitor ripple current stress,  $i_{LC}$ -leakage current,  $T_a$ - ambient temperature.

TABLE II. COMPARISONS OF FAILURE AND SELF-HEALING CAPABILITY OF THE THREE TYPES OF CAPACITORS.

	Al-Caps	MPPF-Caps	MLCC-Caps
<b>Dominant failure modes</b>	wear out		
	open circuit	open circuit	short circuit
<b>Dominant failure mechanisms</b>	electrolyte vaporization; electrochemical reaction	moisture corrosion; dielectric loss	insulation degradation; flex cracking
<b>Most critical stressors</b>	$T_a, V_C, i_C$	$T_a, V_C$ , humidity	$T_a, V_C$ , vibration
<b>Self-healing capability</b>	moderate	good	no

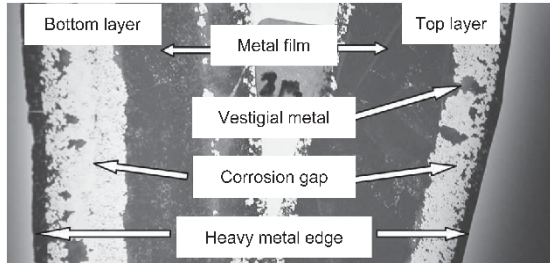

(a) Separation of metal film from heavy edge by corrosion.

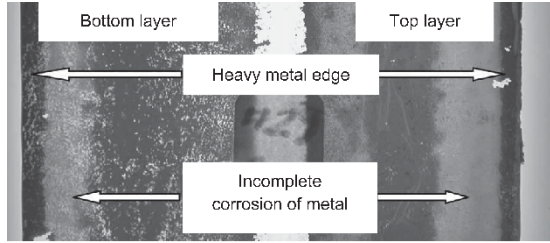

(b) Incomplete edge separation by corrosion.

Fig. 6. Corrosion of the metallized layers of a film capacitor [22].

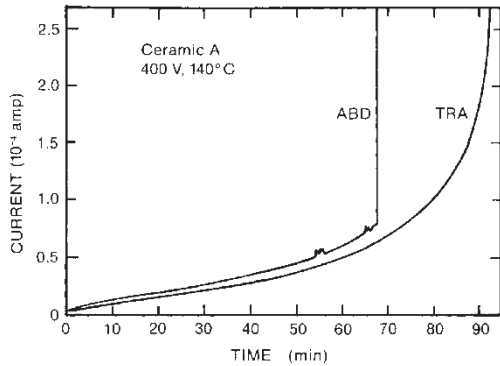

Fig. 7. Leakage current of a barium titanate-based MLC-Cap under high temperature and high voltage stresses (ABD: Avalanche BreakDown, TRA: Thermal RunAway) [18].

the dielectric materials of MLC-Caps are expected to last for thousands of years at use level conditions without showing significant degradation [19]. Therefore, wear out of ceramic capacitors is typically not an issue. However, a MLC-Cap could be degraded much more quickly due to the “amplifying” effect from the large number of dielectric

layers [19]. In [23], it has been shown that a modern MLC-Cap could wear out within 10 years due to increasing miniaturization through the increase of the number of layers. Moreover, the failure of MLC-Caps may induce severe consequences to power converters due to the short circuit failure mode. The dominant failure causes of MLC-Caps are insulation degradation and flex cracking. Insulation degradation due to the decrease of the dielectric layer thickness results in increased leakage currents. Under high voltage and high temperature conditions, Avalanche BreakDown (ABD) and Thermal RunAway (TRA) could occur, respectively. Fig. 7 shows a study in [18] on the leakage current characteristics of a MLC-Cap with ABD and TRA failure. ABD features with an abrupt burst of current leading to an immediate breakdown, while TRA exhibits a more gradual increase of leakage current.

### B. Lifetime Models of DC-Link Capacitors

Lifetime models are important for lifetime prediction, online condition monitoring and benchmark of different capacitor solutions. The most widely used empirical model for capacitors is shown in (1) which describes the influence of temperature and voltage stress.

$$L = L_0 \times \left( \frac{V}{V_0} \right)^{-n} \times \exp \left[ \left( \frac{E_a}{K_B} \right) \left( \frac{1}{T} - \frac{1}{T_0} \right) \right] \quad (1)$$

where  $L$  and  $L_0$  are the lifetime under the use condition and testing condition, respectively.  $V$  and  $V_0$  are the voltage at use condition and test condition, respectively.  $T$  and  $T_0$  are the temperature in Kelvin at use condition and test condition, respectively.  $E_a$  is the activation energy,  $K_B$  is Boltzmann’s constant ( $8.62 \times 10^{-5}$  eV/K), and  $n$  is the voltage stress exponent. Therefore, the values of  $E_a$  and  $n$  are the key parameters to be determined in the above model.

In [24], the  $E_a$  and  $n$  are found to be 1.19 and 2.46, respectively, for high dielectric constant ceramic capacitors. In [23], the ranges of  $E_a$  and  $n$  for MLC-Caps are 1.3 – 1.5 and 1.5 – 7, respectively. The large discrepancies could be attributed to the ceramic materials, dielectric layer thickness, testing conditions, etc. With the trend for smaller size and thinner dielectric layer, the MLC-Caps will be more sensitive to the voltage stress, implying a higher value of  $n$ . Moreover, under different testing voltages, the value of  $n$  might be different as discussed in [25].

For Al-Caps and film capacitors, a simplified model from (1) is popularly applied as follows:

$$L = L_0 \times \left( \frac{V}{V_0} \right)^{-n} \times 2^{\frac{T_0 - T}{10}} \quad (2)$$

The derivation of (2) from (1) is discussed in [26]. The model presented by (2) is corresponding to a specific case of (1) when  $E_a = 0.94$  eV and  $T_0$  and  $T$  are substituted by 398 K. For MPPF-Caps, the exponent  $n$  is from around 7 to 9.4 used by leading capacitor manufacturers [27]. For Al-Caps, the value of  $n$  typically varies from 3 to 5 [28]. However, the

voltage dependency of lifetime for Al-Caps quite depends on the voltage stress level. In [10], instead of a power law relationship, a linear equation is found to be more suitable to describe the impact of voltage stress. To obtain the physical explanations of the lifetime model variants from different capacitor manufacturers, a generic model is derived in [29] as follows:

$$\frac{L}{L_0} = \begin{cases} \left(\frac{V_0}{V}\right) \times \exp\left[\frac{E_a}{K_B} \left(\frac{1}{T} - \frac{1}{T_0}\right)\right] & \text{(low voltage stress)} \\ \left(\frac{V}{V_0}\right)^n \times \exp\left[\frac{E_a}{K_B} \left(\frac{1}{T} - \frac{1}{T_0}\right)\right] & \text{(medium voltage stress)} \\ \exp[a_1(V_0 - V)] \times \exp\left[\frac{E_{a0} - a_0 V}{K_B T} - \frac{E_{a0} - a_0 V_0}{K_B T_0}\right] & \text{(high voltage stress)} \end{cases} \quad (3)$$

where  $a_0$  and  $a_1$  are constants describing the voltage and temperature dependency of  $E_a$ .  $E_{a0}$  is the activation energy under test. It can be noted that the influence of voltage stress is modeled as linear, power law, and exponential equations, respectively for low voltage stress, medium voltage stress and high voltage stress. Another important observation is that the activation energy  $E_a$  is varying with voltage and temperature, especially under high voltage stress conditions.

#### IV. RELIABILITY-ORIENTED DESIGN FOR DC-LINKS

##### A. DC-Link Design Solutions

As the DC-link capacitors contribute to cost, size and failure of power electronic converters on a considerable scale [1], research efforts have been devoted to either optimal design of DC-link capacitor bank [30] or to the reduction of the DC-link requirement [31]. Fig. 8 shows the main types of DC-link design solutions. The most widely applied solution is the one shown in Fig. 8(a) by selecting Al-Caps or MPPF-Caps as discussed in § II. Recently, a hybrid design solution composed of both Al-Caps and MPPF-Caps is proposed in [32] as illustrated in Fig. 8(b). A DC-link with 40 mF Al-Caps bank and a 2 mF MPPF-Cap are selected for a 250 kW inverter, by taking the advantage of their different frequency characteristics. Fig. 9 compares the ripple current stresses in the Al-Caps bank with and without the additional 2 mF film capacitor. By adopting this solution, the reliability of the Al-Caps bank is to be improved due to reduced current stresses. Another research direction is to reduce the energy storage requirement in the DC-link so that Al-Caps could be replaced by MPPF-Caps to achieve higher level of reliability without considerably increase the cost and volume. For example, the concept of Fig. 8(c) is to synchronize the current  $i_{DC1}$  and  $i_{DC2}$  by additional control scheme to reduce the ripple current flowing through the DC-link capacitor [33]. The concept of Figs. 8(d) and (e) is to introduce an additional ripple power port apart from the DC-link [31] and [34]. These two solutions could reduce the overall energy storage requirement of the DC-link as the study cases demonstrated in [31] and [34]. The advantage of the series voltage compensator solution is that the power capacity rating of the compensator is much lower than that of the parallel circuit shown in Fig. 8(d). It is due to very low voltage stresses on the active devices inside the compensator.

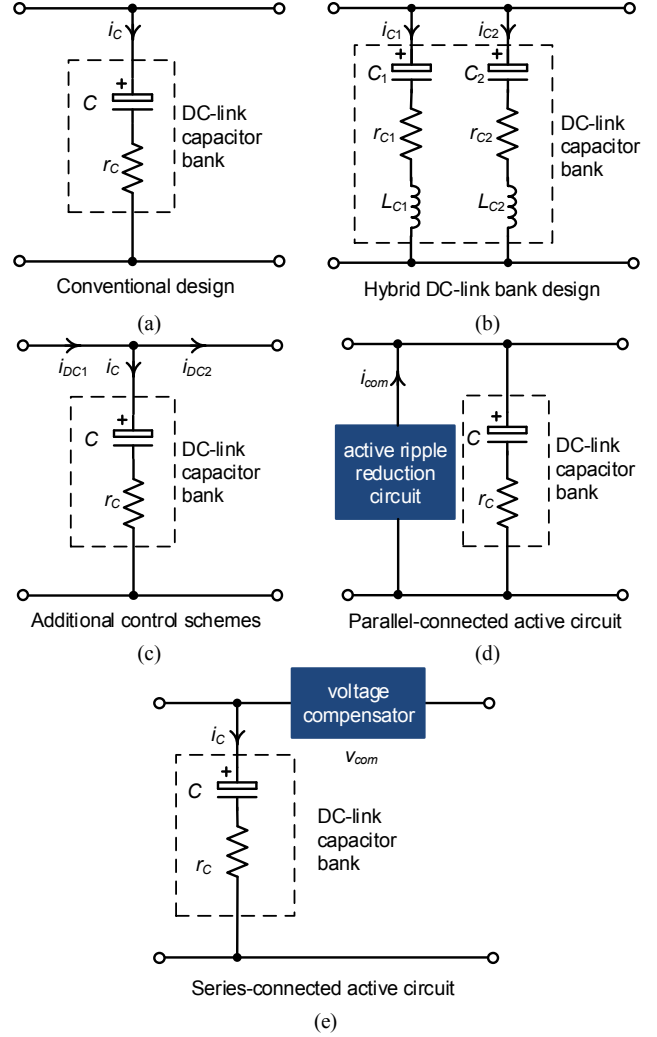

Fig. 8. Main types of solutions for DC-link design.

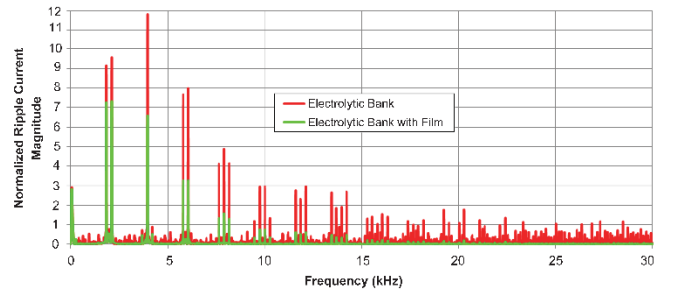
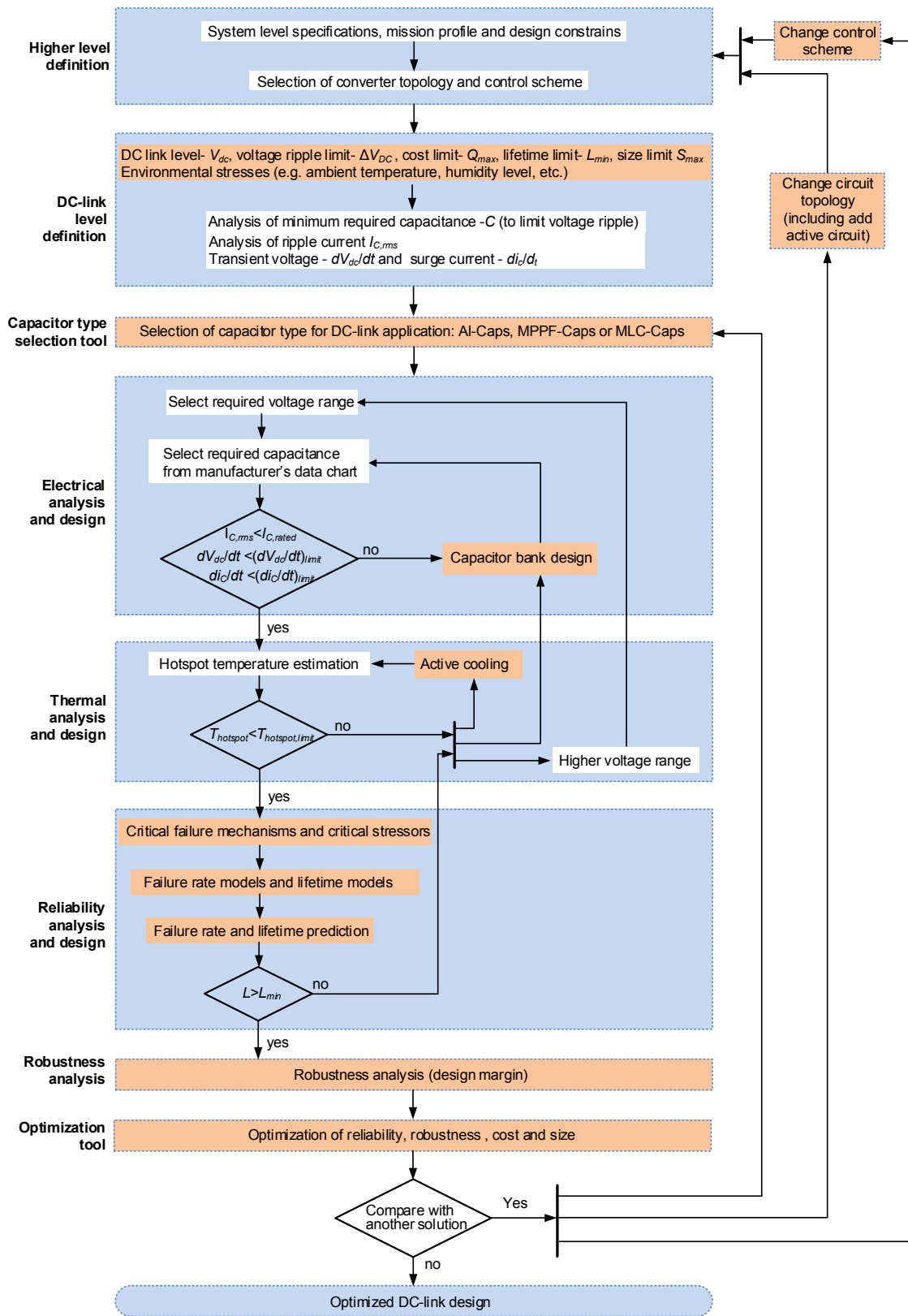

Fig. 9. Ripple current stresses of the 40 mF Al-Caps bank with or without an additional 2 mF film capacitor for a 250 kW inverter application discussed in [32].

##### B. Reliability-Oriented Design Procedure for DC-Link

Besides the possibilities brought by innovative DC-link solutions, a reliability-oriented design procedure could provide further potentials to build the reliability into the DC-link. Fig. 10 presents a reliability-oriented design procedure for DC links. Highlighted areas indicate where further research efforts are expected.



Highlighted area: Future research needs

Fig. 10. Reliability-oriented design procedure for capacitors in DC links.

## V. CONDITION MONITORING OF DC-LINK CAPACITORS

Besides the lifetime prediction and reliability-oriented design, condition monitoring is another important action to improve the reliability of DC-link capacitors for critical applications. Of course condition monitoring may entail important investments in terms of devices, sensors and control scheme. All of them shall be evaluated in terms of cost related to the specific application. Table III shows the typical end-of-life criteria and degradation precursors for Al-Caps, MPPF-Caps, and MLC-Caps.

Impressive research work have been done on the condition monitoring of Al-Caps [35]-[39]. Fig. 11 shows the impedance characteristics of capacitors. In the low frequency range ( $\omega < \omega_1$ ), the impedance is approximated to  $\omega C$ . In the medium frequency range ( $\omega_1 < \omega < \omega_2$ ), the impedance is dominated by the ESR. Therefore, by extracting the voltage and/or current information in the respective frequency ranges, the capacitance and ESR can be estimated.

There are two main principles for ESR estimation: a)  $ESR = V_C / I_C$  where  $V_C$  and  $I_C$  are the Root-Mean-Square (RMS) values of the capacitor voltage and capacitor current in the ohmic region (i.e.  $\omega_1 < \omega < \omega_2$ , typically 5 – 10 kHz) [35]-[37]. The case temperature of the capacitor is usually measured to compensate the temperature dependence of ESR. This method requires two band-pass filters, which should have sufficient bandwidth to extract the frequency components of interest. At the same time, the frequency components below  $\omega_1$  shall be rejected sufficiently. b)  $ESR = P_C / I_C^2$  where  $P_C$  is the average power dissipated in the capacitor and  $I_C$  is the RMS current of the capacitor [38]-[39]. This method does not require specific band-pass filters. The introduction of the sensor in the capacitor current path is not desirable due to its stray inductance.

TABLE III. TYPICAL END-OF-LIFE CRITERIA AND CONDITION MONITORING PARAMETERS

	Al-Caps	MPPF-Caps	MLC-Caps
<b>Failure criteria</b>	C: 20% reduction ESR: 2 times	C: 5% reduction DF: 3 times	C: 10% reduction $R_p < 10^7 \Omega$ DF: 2 times
<b>Degradation precursors</b>	C or ESR, or both	C	C, $R_p$

DF - Dissipation Factor;  $R_p$  - insulation resistance.

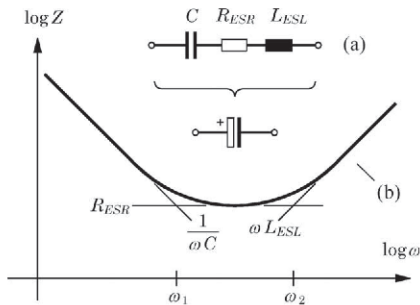

Fig. 11. Impedance characteristics of capacitors [38].

The main applied principle to estimate the capacitance of both Al-Caps and MPPF-Caps is  $C = (\int i_C dt) / \Delta v_C$ , where  $i_C$  is the capacitor current and the  $\Delta v_C$  is the capacitor voltage ripple. In [40], the continuous condition monitoring of MPPF-Caps for an aerospace drive application is presented. To avoid the use of current transducer in series with the DC-link capacitor, the DC-link current  $i_C$  is calculated by the difference between the input current of the motor drive and the input current of the inverter. The measurement system should have a wide bandwidth to capture all of the harmonics of the DC-link voltage ripple (triangular) and have a fast sampling rate.

In [42], an off-line prognostics method for MLC-Caps is presented in which the insulation resistance and capacitance are measured. The methodology is based on the parameter residual generated by the difference between the measured capacitance and its estimation. The method may be difficult to be implemented for online condition monitoring.

## CONCLUSIONS

This paper gives an overview on the reliability aspects of three types of capacitors for DC-link applications in power electronics. Failure modes, failure mechanisms and lifetime models of the capacitors are briefly discussed. Reliability-oriented design approach and condition monitoring methods for DC-link capacitors are presented. Based on this literature review, the following challenges and suggested research directions are addressed:

*Challenges* – a) uncertainties in the mission profile of specific applications, which may lead to unrealistic component level stress analysis; b) variations of the constant parameters in lifetime models (e.g. activation energy, voltage acceleration factor) with external stresses, which require resource-consuming accelerated lifetime testing to investigate them and may not be economic viable to some extent; c) well established lifetime models take into account the stressors of voltage, ripple current and temperature only.

*Suggested Research directions* – a) real time capacitor electrical models that takes into account the operating points (e.g. voltage, ripple current, ambient temperature, frequency, time, etc.) which will contribute to more accurate stress analysis of DC-link capacitors; b) investigation into the coupling effect among various stressors on the lifetime of capacitors; c) the reliability of different DC-link solutions shall be strictly examined as new circuits or software algorithms are introduced which could be the new sources of failure; d) new non-invasive condition monitoring methods with less realization effort and higher estimation accuracy.

## REFERENCES

- [1] H. Wang, M. Liserre, and F. Blaabjerg, "Toward reliable power electronics - challenges, design tools and opportunities," *IEEE Industrial Electronics Magazine*, vol. 7, no. 2, pp. 17-26, Jun. 2013.
- [2] S. Yang, A. T. Bryant, P. A. Mawby, D. Xiang, L. Ran, and P. Tavner, "An industry-based survey of reliability in power electronic converters," *IEEE Trans. Industry Application*, vol. 47, no. 3, pp. 1441- 1451, May/Jun., 2011.

- [3] J. W. Kolar, U. Drofenik, J. Biela, M. L. Heldwein, H. Ertle, T. Friedli, and S. D. Round, "PWM converter power density barriers," in *Proc. Power Conversion Conference*, pp. 9-29, 2007.
- [4] B. W. Williams, *Principles and elements of power electronics: devices, drivers, applications, and passive components*, ch. 26, 2006
- [5] M. Marz, A. Schletz, B. Eckardt, S. Egelkraut, and H. Rauh, "Power electronics system integration for electric and hybrid vehicles," in *Proc. International Conference on Integrated Power Electronics Systems (CIPS)*, 2010.
- [6] G. Kuegerl, "Technologies & products press conference - CeraLink™ - new dimensions in capacitor technology," Presentation in Nov. 2012. Online: [http://www.epcos.com/web/generator/Web/Sections/Home/TPC/TPC\\_2012/PDF/Presentation\\_Kuegerl.pdf,property=Data\\_en.pdf/Presentation\\_Kuegerl.pdf](http://www.epcos.com/web/generator/Web/Sections/Home/TPC/TPC_2012/PDF/Presentation_Kuegerl.pdf,property=Data_en.pdf/Presentation_Kuegerl.pdf).
- [7] L. L. Macomber, "Aluminum electrolytic capacitors in power electronics," *Cornell Dubilier special session presentation at the IEEE Applied Power Electronics Conference and Exposition*, 2011.
- [8] H. Wen, W. Xiao, and P. Armstrong, "Analysis and evaluation of DC-link capacitors for high-power-density electric vehicle drive systems," *IEEE Trans. Vehicular Technology*, vol. 61, no. 7, pp. 2950-2964, Sep. 2012.
- [9] R. S. Alwitt and R. G. Hills, "The chemistry of failure of aluminum electrolytic capacitors," *IEEE Trans. Parts Materials and Packaging*, vol. PMP-I, no. 2, pp. 28-34, Sep. 1965.
- [10] Cornell Dubilier, *Application guide, aluminum electrolytic capacitors*. Online: <http://www.cde.com/catalogs/AEappGUIDE.pdf>
- [11] EPCOS, Aluminum electrolytic capacitors, general technical information, Nov. 2012. Online: [http://www.epcos.com/web/generator/Web/Sections/ProductCatalog/Capacitors/AluminumElectrolytic/PDF/PDF\\_GeneralTechnicalInformation,property=Data\\_en.pdf](http://www.epcos.com/web/generator/Web/Sections/ProductCatalog/Capacitors/AluminumElectrolytic/PDF/PDF_GeneralTechnicalInformation,property=Data_en.pdf)
- [12] Nippon Chemi-con, Aluminum capacitors catalogue - Technical note on judicious use of aluminum electrolytic capacitors, 2013. Online: <http://www.chemi-con.com/2013AluminumElectrolyticCatalog.pdf>
- [13] A. Ritter, "Capacitor reliability issues and needs," *Presentation at the Sandia National Laboratories Utility-Scale Grid-Tied PV Inverter Reliability Technical Workshop*, Jan. 2011.
- [14] Q. Sun, Y. Tang, J. Feng, and T. Jin, "Reliability assessment of metallized film capacitors using reduced degradation test sample," *Journal of Quality and Engineering International*, vol. 29, no. 2, pp. 259-265, Mar. 2013.
- [15] Kemet Technical Note, Power electronics film capacitors. Online: [http://www.kemet.com/kemet/web/homepage/kehome.nsf/weben/ADFCC3E8AD80F8B85257713006A103F/\\$file/F9000\\_Film\\_Power.pdf](http://www.kemet.com/kemet/web/homepage/kehome.nsf/weben/ADFCC3E8AD80F8B85257713006A103F/$file/F9000_Film_Power.pdf)
- [16] EPCOS, Film capacitors - general technical information, May 2009. Online: [http://www.epcos.com/web/generator/Web/Sections/ProductCatalog/Capacitors/FilmCapacitors/PDF/PDF\\_GeneralTechnicalInformation,property=Data\\_en.pdf/PDF\\_GeneralTechnicalInformation.pdf](http://www.epcos.com/web/generator/Web/Sections/ProductCatalog/Capacitors/FilmCapacitors/PDF/PDF_GeneralTechnicalInformation,property=Data_en.pdf/PDF_GeneralTechnicalInformation.pdf)
- [17] Electronicon, Capacitors for power electronics - application notes-selection guide, Mar. 2013. Online: [http://www.electronicon.com/fileadmin/inhalte/pdfs/downloadbereich/Katalog/neue\\_Katalog\\_2011/application\\_notes.pdf](http://www.electronicon.com/fileadmin/inhalte/pdfs/downloadbereich/Katalog/neue_Katalog_2011/application_notes.pdf)
- [18] B. S. Rawal and N. H. Chan, "Conduction and failure mechanisms in Barium Titanate based ceramics under highly accelerated conditions," *AVX coporation Technical Information*, 1984.
- [19] D. Liu and M. J. Sampson, "Some aspects of the failure mechanisms in BaTiO<sub>3</sub> - Based multilayer ceramic capacitors," in *Proc. CARTS International*, 2012, pp. 59-71.
- [20] M. J. Cozzolino, "Electrical shorting in multilayer ceramic capacitors," in *Proc. CARTS International*, 2004, pp. 57-68.
- [21] J. L. Stevens, J. S. Shaffer, and J. T. Vandenharn, "The service life of large aluminum electrolytic capacitors: effects of construction and application," *IEEE Trans. Industry Application*, vol. 38, no. 5, pp. 1441-1446, Sep./Oct. 2002.
- [22] R. W. Brown, "Linking corrosion and catastrophic failure in low-power metallized polypropylene capacitors," *IEEE Trans. Device Material Reliability*, vol. 6, no. 2, pp. 326-333, Jun. 2006.
- [23] C. Hillman, "Uprating of ceramic capacitors," *DfR Solution white paper*.
- [24] W. J. Minford, "Accelerated life testing and reliability of high K multilayer ceramic capacitors," *IEEE Trans. Components, Hybrids, and Manufacturing Technology*, vol. CHMT-5, no. 3, pp. 297-300, Sep. 1982.
- [25] N. Kubodera, T. Oguni, M. Matsuda, H. Wada, N. Inoue, and T. Nakamura, "Study of the long term reliability for MLCCs," in *Proc. CARTS International*, 2012, pp. 1-9.
- [26] S. G. Parler, "Deriving life multipliers for electrolytic capacitors," *IEEE Power Electronics Society Newsletter*, vol. 16, no. 1, pp. 11-12, Feb. 2004.
- [27] Emerson Network Power, "Capacitors age and capacitors have an end of life," *White paper*.
- [28] A. Albertsen, "Electrolytic capacitor lifetime estimation," Jianghai Capacitor technical note. Online: [http://jianghaiamerica.com/uploads/technology/JIANGHAI\\_Elcap\\_Lifetime\\_-\\_Estimation\\_AAL.pdf](http://jianghaiamerica.com/uploads/technology/JIANGHAI_Elcap_Lifetime_-_Estimation_AAL.pdf)
- [29] H. Wang, K. Ma, and F. Blaabjerg, "Design for Reliability of Power Electronic Systems," in *Proc. of IEEE Industrial Electronics Society Annual Conference*, pp. 33-44, 2012.
- [30] P. Pelletier, J. M. Guichon, J. L. Schanen, and D. Frey, "Optimization of a DC capacitor tank," *IEEE Trans. Industry Application*, vol. 45, no. 2, pp. 880-886, Mar./Apr., 2009.
- [31] H. Wang, H. S. H. Chung, and W. Liu, "Use of a series voltage compensator for reduction of the dc-link capacitance in a capacitor-supported system," *IEEE Trans. Power Electronics* (in press), 2014.
- [32] M. A. Brubaker, D. El Hage, T. A. Hosking, H. C. Kirbie, and E. D. Sawyer, "Increasing the Life of Electrolytic Capacitor Banks Using Integrated High Performance Film Capacitors," *PCIM 2013 Europe*.
- [33] I. S. Freitas, C. B. Jacobina, and E. C. Santos, "Single-phase to single-phase full-bridge converter operating with reduced AC power in the DC-link capacitor," *IEEE Trans. Power Electronics*, vol. 25, no. 2, pp. 272-279, Feb., 2010.
- [34] R. X. Wang, F. Wang, D. Boroyevich, R. Burgos, R. X. Lai, P. Q. Ning, and K. Rajashekara, "A high power density single-phase PWM rectifier with active ripple energy storage," *IEEE Trans. Power Electronics*, vol. 26, no. 5, pp. 1430-1443, May 2011.
- [35] K. Harada, A. Katsuki, and M. Fujiwara, "Use of ESR for deterioration diagnosis of electrolytic capacitor," *IEEE Trans. Power Electron.*, vol. 8, no. 4, pp. 355-361, Oct. 1993.
- [36] K. P. Venet, F. Perisse, M. H. El-Husseini, and G. Rojat, "Realization of a smart electrolytic capacitor circuit," *IEEE Industry Application Magazine*, vol. 8, no. 1, pp. 16-20, 2002.
- [37] A. M. Imam, T. G. Habetler, R. G. Harley, and D. Divan, "Failure prediction of electrolytic capacitors using dsp methods," in *Proc. IEEE Appl. Power Electron. Conf.*, pp. 965-970, 2005.
- [38] M. A. Vogelsberger, T. Wiesinger, and H. Ertl, "Life-cycle monitoring and voltage-managing unit for DC-Link electrolytic capacitors in PWM converters," *IEEE Trans. Power Electronics*, vol. 26, no.2, pp. 493-503, Feb. 2011.
- [39] E. Aeloiza, J. H. Kim, P. Enjeti, and P. Ruminot, "A real time method to estimate electrolytic capacitor condition in PWM adjustable speed drives and uninterruptible power supplies," in *Proc. IEEE Power Electron. Specialists Conf.*, pp. 2867-2872, 2005.
- [40] A. Wechsler, B. C. Mecrow, D. J. Atkinson, J. W. Bennett, and M. Benarous, "Condition monitoring of DC-link capacitors in aerospace drives," *IEEE Trans. Industry Applications*, vol. 48, no.6, pp. 1866-1874, Nov./Dec. 2012.
- [41] J. Sun, S. Cheng, and M. Pecht, "Prognostics of multilayer ceramic capacitors via the parameter residuals," *IEEE Trans. Device and Materials Reliability*, vol. 12, no. 1, pp. 49-57, Mar. 2012.