



Aalborg Universitet

AALBORG UNIVERSITY  
DENMARK

## Educational Value and Lessons Learnt from the AAU-Cubesat Project

Alminde, Lars; Bisgaard, Morten; Vinther, D.; Viscor, T.; Østergaard, Kasper Zinck

*Publication date:*  
2003

*Document Version*  
Publisher's PDF, also known as Version of record

[Link to publication from Aalborg University](#)

*Citation for published version (APA):*  
Alminde, L., Bisgaard, M., Vinther, D., Viscor, T., & Østergaard, K. Z. (2003). *Educational Value and Lessons Learnt from the AAU-Cubesat Project*. <Forlag uden navn>.

### General rights

Copyright and moral rights for the publications made accessible in the public portal are retained by the authors and/or other copyright owners and it is a condition of accessing publications that users recognise and abide by the legal requirements associated with these rights.

- ? Users may download and print one copy of any publication from the public portal for the purpose of private study or research.
- ? You may not further distribute the material or use it for any profit-making activity or commercial gain
- ? You may freely distribute the URL identifying the publication in the public portal ?

### Take down policy

If you believe that this document breaches copyright please contact us at [vbn@aub.aau.dk](mailto:vbn@aub.aau.dk) providing details, and we will remove access to the work immediately and investigate your claim.

# EDUCATIONAL VALUE AND LESSONS LEARNED FROM THE AAU-CUBESAT PROJECT

Lars Alminde\*, Morten Bisgaard, Dennis Vinther, Tor Viscor and Kasper Østergard  
Department of Control Engineering at Aalborg University Denmark.  
{lalm00,mbis00,drvi00,tvis00,kzoe00}@control.auc.dk

**Abstract.** In September 2001 Aalborg university started the AAU-cubesat project that reached its climax when the student built satellite was launched into space on the 30th of June 2003 on top of a former Russian ICBM.

AAU-cubesat was among the first five satellites to be launched that are built within the cubesat concept that prescribes a satellite with dimensions 10x10x10cm and mass one kilogram. These constraints clearly limit the possibilities for the satellite in terms of possible scientific missions, but on the other hand: by building satellites of this size a technology push is created that in the future will help to reduce the size of both scientific and commercial satellites and thus help to drive down the launch cost.

This paper will describe the overall architecture of the AAU-cubesat in order to show what a pico-satellite can be and demonstrate all the fields of engineering which must come together to build a student satellite like the AAU-cubesat.

Results from the operation phase will be stated, and recommendations on further work on pico-satellite designs will be given. In addition as the project has been carried through by students then the educational value of the project will be addressed as well.

## 1 Introduction

In the summer of 2001 it was decided to initiate the AAU-Cubesat project at Aalborg University in Denmark. This project was made possible due to the cubesat concept, which has been developed at Stanford University and California polytechnic institute led by professor Bob Twiggs [3]. This concept allows a satellite of dimensions 10x10x10cm and mass 1kg to be launched into low Earth Orbit at a total launch cost of about \$40,000.

The motivation was to let engineering students from various departments cooperate in the completion of a very large project and thereby give them a unique chance to participate in a project that not only needs good engineering skills, but also the skills to solve problems that are inter-disciplinary in nature.

In the initial period of the project it was decided by the students that the scientific mission of the project should be Earth Observation and many ideas were studied, but they were all

found to be technically challenging to implement on a platform as small as the cubesat. After many meetings it was finally decided to fly a camera without a specific scientific purpose for it, but rather use the satellite as a technology evaluation mission preparing the ground for future scientific missions using the cubesat concept.

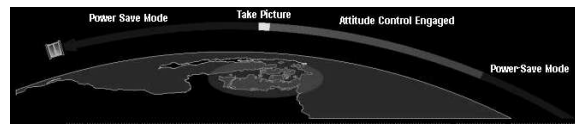

Figure 1. Illustration of the mission concept

Following the definition of the mission the project success criteria were defined in an incremental manner:

1. Education of engineers, practical experience with designing space system
2. Acquire a signal from the satellite
3. Acquire comprehensive housekeeping data for system evaluation
4. Use the camera for public outreach mission and performance evaluation.

Using this definition the project was defined such that it would still be a partly success even though no signal was ever received from the satellite. A conceptual illustration of the nominal mission scenario is depicted in figure 1. When considering the project it is important to remember that it was constrained by:

- Very short project, <2 years from idea to launch
- Very limited budget
- Limited mass and power
- Build by students with no prior experience with spacecraft design

The satellite was completed in April 2003 and was transported to Canada, together with three students, to undergo environmental qualification tests together with the other satellites to be deployed from the same deployment mechanism.

From Canada it was transported to Plesetsk in Russia, where it was functionally tested and the batteries were conditioned before the launch on the 30th of June 2003.

The following sections will at first describe the satellite and all its subsystems, where after launch an operational results are presented. Thereafter the educational benefits are described and finally conclusion and recommendations for future projects are given.

## 2 Satellite Description

The following paragraphs will describe the various mechanical, electrical and software subsystems of the satellite, hereby providing an overview of the architecture of a pico-satellite. As already described the satellite has dimensions 10x10x10cm and mass 1 kg.

In general for the electrical subsystems industrial graded components were used of the shelf. Some of the more critical components CPU's and MCU's have been tested following exposure to one year equivalent radiation dose. The satellite includes of 5 electrical subsystems, these are:

- PSU: Power Supply Unit
- OBC: On Board Computer
- ADCS: Attitude Determination and Control System
- COM: Communication system
- CAM: Camera - the payload

In addition to these electrical subsystems the satellite consists of the structural subsystem, OBC software system and a ground segment has also been developed for the project. The following paragraphs will describe each part in a little more detail. For more information on the technological part of the project consult the project home-page [1].

### 2.1 Power Supply Unit

The main purpose of the PSU is to take power from the solar cells on the sides of the satellite and store it in the batteries as well as deliver it to the other subsystems of the satellite on a 5V power-bus and protect these users from latch-ups caused by radiation. The PSU consists of solar panels, electronics and batteries.

The solar cells are triple junction GaAs cells from EMCORE with a efficiency of 28% (beginning of life) and a maximum power point of at about 4.2 V. To acquire the maximum power input the electronics controlling the PSU must actively perform Maximum Power Point Tracking (MPPT) to control the solar-panel voltages and currents for a maximal power output. This is done using a small micro-controller.

A conservative estimate of average input power of is about 1.4 W. This powerestimate input constitutes one of the major constraints in the design and has been the driving force behind many design decisions.

The acquired energy is either consumed by the other subsystems or stored in the battery pack. The batteries are 4 Lithium-Ion polymer cells with a capacity of 940mAh each, giving a total

capacity of almost 4Ah. The batteries are connected 2 and 2 in series and each string has got a protection circuit (UCC3911) to ensure that the batteries does no become over or under charged. A picture of a single battery is provided on figure 2.



**Figure 2.** The Li-Ion polymer batterytype used on the cubesat

For the step up in voltage from the solar cells to the batteries a standard boost-converter is used and it is controlled by the MCU which runs maximum power point tracking (MPPT) on it. For the step down from the batteries to the power bus a buck converter from Maxim (MAX1744) is used. The duty-cycle of the boost-converter is controlled by the micro-controller, which performs the power tracking using a perturbation and evaluation algorithm.

In addition to the main task of energy conversion and storage the PSU collects various housekeeping data and transmits them to the OBC over an I2C-bus that connects the different subsystems. Finally the PSU is responsible for securing the other subsystems against latch-up events. If a latch-up is detected the corresponding sub-system is shut down and then automatically powered up 5 minutes later, except for ACS and CAM which must explicitly be turned on from a ground command.

### 2.2 On Board Computer

The On-Board Computer (OBC) is the brain of the satellite and it features a Siemens C161 micro controller which combines low power consumption with great performance. It operates at 10MHz and has got 4 Mb of RAM of which the picture will take about 2Mb. Further the OBC has 512kB of PROM which will hold the initial software and further it has 256kB of flash ROM which will be used to upload new software to the satellite after launch. The hardware interfaces are: the power line and boot-selector from the PSU, I2C connections from PSU and ACS, a combined DMA and I2C interface to the camera and a parallel interface to the COM-unit.

The OBC is the master of the I2C-bus on the satellite and the PSU, ACS and CAM subsystems are slaves on the bus, which

only responds to requests from the OBC. The I2C-bus is used for two primary purposes; primarily it is used to acquire house-keeping information from the various subsystems and secondly it is used to send commands to the subsystems.

The OBC has the option of booting either on a PROM with the original software the satellite was launched with or on FLASH-ROM with contains new software uploaded to the satellite from the ground station. This boot selection is controlled by the PSU by a special algorithm which continuously tries to boot the OBC from either PROM or flash until it has been successfully booted.

The command interface to the camera is the I2C-bus, but when the picture is taken it is moved directly into the RAM of the OBC by a DMA interface. During this time the C161 MCU of the OBC is disabled from the databus and executes camera control code from an internal RAM-space of 2kb.

The RS-232 UART interface of the OBC is used as an alternative communication entry to the OBC for on ground check out operations and debugging. The RS-232 lines are routed to the external data connector of the satellites, such that debugging can be carried out while the satellite is mounted on the upper stage of the rocket.

### 2.3 Attitude Determination and Control System

In order to be able to take pictures of specific locations on the Earth the AAU-cubesat features an ACDS system. To control the satellites attitude in orbit three coils are used, which are mounted on three of the satellites sides perpendicular on each other. These will generate magnetic fields, which interact with the Earth's magnetic field, and hereby change the attitude of the satellite.

To determine the satellites attitude two types of sensors are used. A three axis magnetometer, build up with components from HONEYWELL, to provide information on the direction of the magnetic field of the Earth, and sun sensors.

The sensor inputs are fed to an extended kalman filter with additional input from an orbit propagation model (SGV4) is able to determine the state vector of the satellite in quaternion form. The satellite has two controller modes: B-dot and inertial.

The B-dot controller is used when the system boots. At this point the satellite does not have any orbital parameters it can use for attitude determination. The B-dot controller then simply works by reducing the kinetic energy of the satellite by providing negative feedback from the derivative of the measured magnetic field. This means that the satellite will align itself with the local magnetic field and thus rotate  $4 \cdot \pi$  around the axis lying in direction of the velocity vector.

When ground contact has been made and orbital parameters uploaded to the satellite the Kalmanfilter begins to converge on the correct attitude and the inertial (wrt. to the sun) control mode can be employed. This controller is a constant gain controller for the linear time varying plantmodel.

On figure 3 the ACS operational principle can be seen. Ini-

tially it starts the B-dot controller and when the angular velocities are below a certain threshold or on a timeout the ACDS systems goes to the IDLE state. From the idle state ground commands can command the ACDS to either go to B-dot mode or one of two inertial modes with the only difference being if the reference vector is specified for camera operations or power saving (three panels towards the sun).

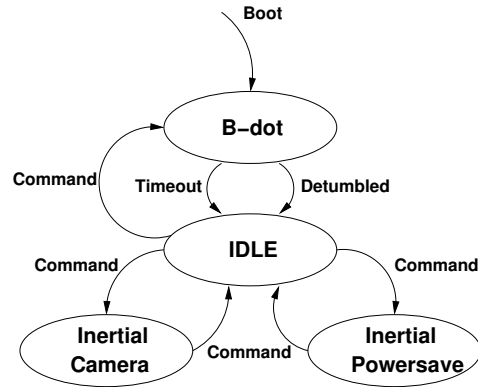

Figure 3. Operation modes of the ACS system

Included in the ACDS software are various algorithms to detect sensor fault or degradations. Due to the redundant attitude determination is robust against any single sensor fault.

The ACDS system has its own dedicated PIC-controller that performs most of the work autonomously. However, due the rather complex algorithms involved, the OBC performs some of the algorithms for the ADCS system, specifically the Extended Kalman filter. The two systems communicate using the I2C-bus.

### 2.4 Communication System

The communication systems is controlled from the OBC and it consists of a MX909 packet modem and a SX-450 telemetry radio. In addition the AX25 protocol for amateur packet radio is implemented on the OBC.

The radio transmits at a power of 0.5 W and the modem outputs a GMSK modulated signal with a data-rate of 9600 Baud. The radio output is transmitted using two dipole antennas and the frequency used is 437.450 MHz. This frequency has been obtained through the Amateur satellite association AMSAT. The worst case link margin has been calculated to 10.7dB. The antennas (a crossed di-pole) are folded during launch and then deployed using a simple burn-resistor when seperated from the launcher.

Given the bandwidth provided by the COM system it was expected that it would be possible to acquire a new picture taken by the camera every second day, while still leaving bandwidth to acquire housekeeping information and command the satellite.

The radio design was conceived very late in the process due to an initial subcontractors<sup>1</sup> failure to deliver a usable product. This means that the subsystem has not been tested as extensively as it ought to.

## 2.5 Camera

The camera is based around a Kodac CMOS image sensor that provides a resolution of 1280x1024 pixels in 24bit colors. The lens systems for the camera has been customly built for this project and it will provide an on ground resolution of approximately 150x120 meter from a 900 km orbit. An exploded view of the lens and camera system can be seen on figure 4.

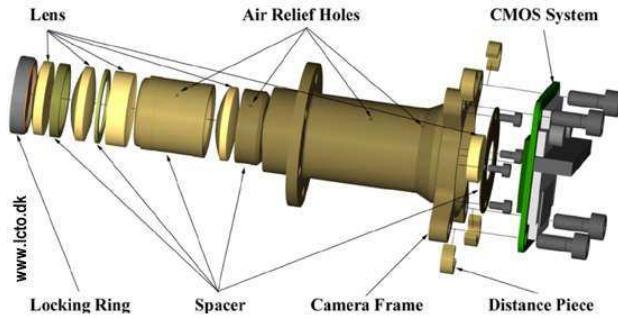

Figure 4. Exploded view of the camera subsystem

The camera is only turned on while taking the picture. Pictures are always taken in full resolution, but it is possible to downlink a thumbnail version of the picture before beginning to download the complete picture. It is possible to configure various camera parameters in orbit, e.g. integration time and color gains.

## 2.6 Software

On the OBC the software controlling the satellite is executed. It has the following main functionality:

- Transmits beacon signals with an interval depending on power status
- Controls the actions of the satellite based on a flightplan uploaded from the ground station
- Reacts to subsystem alarms, e.g. low power signaled from the PSU
- Collects and store housekeeping information from all subsystems
- Calculates the attitude of the satellite with regards to the sun based on sensor data from the ACS subsystem
- Manages communication with the ground station using the AX25 protocol
- Logs everything that goes on on the satellite to a central satellite log

<sup>1</sup> Initial it was decided to purchase the radio from an external supplier

The software is developed using the Keil  $\mu$ -vision IDE and it runs on top of the Keil RTX-166 real-time kernel. The functionality is implemented in a number of independent tasks that communicates using mailboxes, see figure 5.

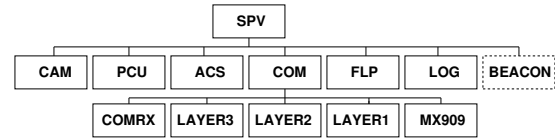

Figure 5. Task hierarchy in the OBC software

As can be seen from the figure a number of the abbreviations are recognizable, since each electrical subsystem (other than the OBC itself) has a software task dedicated to interface and control that particular subsystem. The supervisor task (SPV) is the main task that oversees satellite activities and distributes commands, e.g. by initiating collection of housekeeping data.

The FLP-task maintains a flightplan uploaded from the groundstation containing both single commands, e.g. take a picture and periodic commands as for example collect housekeeping information.

The LOG-task receives log entries from the other tasks and the debugging and fault control functions. The log is stored in a linked list and when requested from ground it is assembled in a continous file and downlinked.

The BEACON-task is responsible for transmitting a housekeeping beacon, containin temperature, battery voltage, internal time and number of software errors, every two minutes in normal power mode and every 2 minutes and 50 seconds in low power mode. The beacon is not transmitting while the data link connection is open.

As can be seen the COM-task has a lot of sub-tasks, which are due to the relative complexity of the nearly full implemented AX25 protocol, and to some extend also the RTX-166's inability to let tasks block on multiple mailboxes.

While the software does not explicitly manage to detect and correct the effects of single-event-upsets (SEU) it is designed such that any SEU's cannot block normal operation infinitely. Either the OBC software or the PSU (Through a watchdog mechanism) will detect that something is wrong and reboot the OBC. New software can be uploaded to the OBC FLASH-rom if required.

## 2.7 Mechanical Structure

The structural system consists of a frame cut from one piece of aluminum and side panels made in carbonfibres to conserve mass. Also in order to conserve mass the electro-magnetic coils are implemented as part of the structure.

The internal structural composition is such that the camera lens-systems is mounted on the middle of one side of the satellite with the lens occupying the center of the satellite. On the

remaining five sides print boards are positioned. An exploded view of the satellite main structures can be seen on figure 6

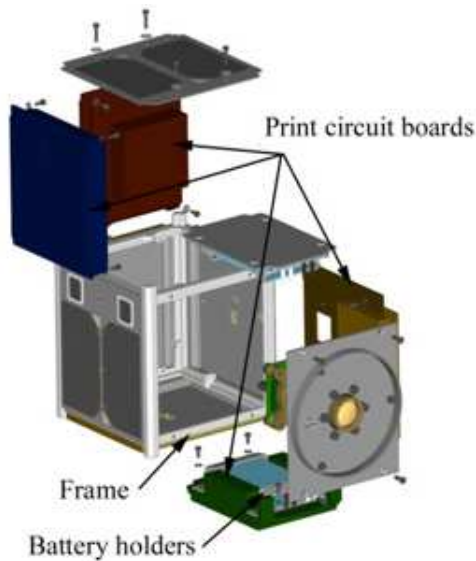

**Figure 6.** The satellite structure, exploded view

High requirements have been set regarding the structure of the satellite and its integrity, as it has to withstand high temperature variations, vibrations and shocks, radiation, and the vacuum in space.

Simplified thermal characteristic simulations have been carried out for the mechanical structure including the print circuit boards in order to evaluate what the temperatures will be within the structure where the electronics are placed. These simulations have indicated temperatures between 0 to 40° C. Depending on solar influx (eclipse time).

## 2.8 Ground Segment

The ground segment that has been developed for the project consists of a tracking antenna, an off-the-shelf amateur radio, a modem similar to that on the satellite and a PC. The software on the PC is capable of controlling the satellite autonomously, i.e. acquire signal, download housekeeping data and upload new flightplans, or it can be operated by an operator. All downloaded data are stored in a central database.

## 3 Launch and Operation Results

The satellite was launched on the 30th of June 2003 from the Plesetsk Cosmodrome in northern Russia. The launch vehicle was the Rockot operated by Eurockot. The launch was shared with 6 other satellites: The MOST satellites from the Canadian Space Agency, The MIMOSA from the Czech Republic, Quakesat from the Quakefinder company and the cubesats: DTUsat (Danish Technical University), CanX-1 (university of

Toronto), Cute-1 (Tokyo Institute of Technology) and XI-IV (university of Tokyo). The satellites were launched into a near sun-synchronous orbit (inclination 98.73°), the orbit is near circular with mean altitude above the geoid of 820km.

In the first days following launch it took a lot of coordinated effort of all the involved operation teams, together with the NORAD tracking radars, to locate and identify all the satellites separated from the launch vehicle.

For the first 24 hours no distinct signal was heard from AAU-cubesat, but hereafter the operation team was able to detect the beacon signal with increasing confidence. After about 4 days it was clear that the satellite had been successfully located, but the transmitted signal strength was far below expected. Therefore the groundstation was relocated 200 km to make use of an 8m dish antenna.

When the new groundstation was finally fitted for operations in the correct frequency (1 month after launch) signal was received with enough strength to decode some of them, but at this point the beacon intervals and the decoded signals started to indicate massive loss of battery capacity leading to frequent returns to the contingency charge mode of operation, which does not supply power to the OBC.

Unfortunately the degraded battery condition made it impossible to establish a real datalink connection and download extensive house keeping data, but simple two-way communication was established (pinging) demonstrating that the complete datapath from groundstation to OBC and back was functional.

In addition to battery voltages, temperatures of the OBC processor were received and decoded with the advanced beacon signal. These indicated a temperature of an average of 28°C consistent with the values predicted with the thermal model (orbit entirely in sun).

On figure 7 an example of a received signal is plotted. Specifically it is a basic beacon, which is a special beacon signal transmitted prior to OBC boot, when leaving the battery contingency charge mode. The signal contains an identifier and battery voltage as a simple morse signal.

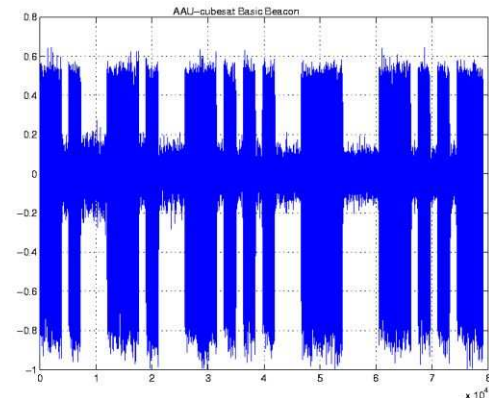

**Figure 7.** The basic beacon signal as received on the 20th of August

### 3.1 Failure Analysis

From the operational phase two problems were identified:

1. Transmitted signal is far weaker than expected
2. Battery has lost almost all its capacity

The first point has not been investigated intensively. As previously mentioned the communication system was a "last minute design", due to the failure of the contracted company to deliver. The design was done by students with no prior experience with radio communication.

During development it was found that the batteries lost capacity when exposed to vacuum, because the internal layers making up the battery got separated. This was solved by mounting the batteries such that pressure is applied to the battery. Then during a week long test the batteries showed no non-nominally loss of capacity. However after a month in space the batteries had again lost substantially capacity. Further long term vacuum testing on ground remains to be performed in order to evaluate the exact reason for failure.

### 4 Educational Value

The project has from its start been controlled by the students involved in the project. Each student has been part of a group of about 5 students that have had the responsibility for one single subsystem of the satellite. This approach has not only given the students a profound insight into the specific subsystem that he/she has been working on, but due to the highly integrated architecture of a pico-satellite it has also been necessary for each student to have a good overview of the other satellite subsystems in order to be successful. To be a part of a project like this is very motivating and the problems to be solved on a pico-satellite are very technically challenging.

The project has therefore provided the student with a very beneficial educational opportunity that has both focused on a single technical design while also teaching the student to coordinate work within a group and coordinate work between groups working on different parts of the satellite. In addition it is something one can be proud to be a part of.

The project included engineering students from the following departments of the natural science faculty at the university:

- Mechanical engineering
- Control engineering
- Electrical engineering
- Power systems
- Computer science

The period following launch also showed itself to be very educating for the students participating in the operation of the satellite. The challenge of locating the satellite, understand the problems and try and recover the mission was a good and educating exercise for all involved.

The project has also received a lot of attention from the media and younger (prospective) students at the university. And it

is clear that a lot of students are interested in continuing building student satellites. To that end a new satellite is currently in its definition phase and development will start in January. For further information on the educational benefits from the project see [2].

### 5 Conclusion and Recommendations

Concluding from the flight results from AAU-cubesat it can be said that the platform is not yet mature enough to be reliable used for scientific experiments, but it must be seen as a first step within pico-satellite design. Out of the 5 Cubesats launched together on the Rockot two failed to make any contact with their groundstation, one (AAU-cubesat) did make contact, but operations are severely limited. Finally both Japanese satellites are operating nominally.

For the future design of student built pico-satellites a few important recommendations can be made:

- The launch should not be fixed when the project is initiated; it is better to have the satellite standing on a shelf for half a year than launching a half finished satellite. It is difficult to predict the development time of the satellite, specially when the work is performed by students with little experience
- Keep the designs simple; design conservatively and make sure to consider how the satellite operates under the presence of faults and make sure to implement simple and robust initial operating modes. More advanced operation should then be enabled incrementally when ground contact has been established.
- When selecting parts for use on the satellite with regard to the space environment there exists two options; one can by components that are guaranteed to withstand the environment or one can by commercial parts and test them vigorously. The latter option is cheaper and more educating and therefore the most suitable for this type of satellite.

In conclusion the AAU-project has achieved two major results: Primarily a large group of students will leave the university with a great deal of "Hands-on experience" within satellite design and experience with working with a large project that requires cooperation between everybody that are involved. Secondly, while post-launch operations have not yet fulfilled all mission objectives, it has provided enough feedback to provide a sound starting point for the next nano-satellite project at Aalborg university, which will utilize all the experience gained from the AAU-cubesat project.

### REFERENCES

- [1] AAU-CUBESAT, *AAU-cubesat homepage*, Aalborg University, 2003. [www.cubesat.auc.dk](http://www.cubesat.auc.dk).
- [2] Lars Alminde, *Educational Benefits from the AAU-cubesat Student Satellite Project*, AAIA/IAC, 2003. IAC 2003 conference paper: IAC 03-01-P.1-08.
- [3] Bob Twiggs and Jordi Puig-Suari, *CUBESAT Design Specifications Document*, Stanford University and California Polytechnical Institute, 2003. Can be downloaded from [www.cubesat.org](http://www.cubesat.org).