



## Secondary Voltage Control for Harmonics Suppression in Islanded Microgrids

Wang, Xiongfei; Guerrero, Josep M. ; Blaabjerg, Frede; Chen, Zhe

*Published in:*

Proceedings of the IEEE Power and Energy Society General Meeting 2011

*DOI (link to publication from Publisher):*

[10.1109/PES.2011.6039871](https://doi.org/10.1109/PES.2011.6039871)

*Publication date:*

2011

*Document Version*

Early version, also known as pre-print

[Link to publication from Aalborg University](#)

*Citation for published version (APA):*

Wang, X., Guerrero, J. M., Blaabjerg, F., & Chen, Z. (2011). Secondary Voltage Control for Harmonics Suppression in Islanded Microgrids. In *Proceedings of the IEEE Power and Energy Society General Meeting 2011* (pp. 1-8). IEEE Press. <https://doi.org/10.1109/PES.2011.6039871>

### General rights

Copyright and moral rights for the publications made accessible in the public portal are retained by the authors and/or other copyright owners and it is a condition of accessing publications that users recognise and abide by the legal requirements associated with these rights.

- Users may download and print one copy of any publication from the public portal for the purpose of private study or research.
- You may not further distribute the material or use it for any profit-making activity or commercial gain
- You may freely distribute the URL identifying the publication in the public portal -

### Take down policy

If you believe that this document breaches copyright please contact us at [vbn@aub.aau.dk](mailto:vbn@aub.aau.dk) providing details, and we will remove access to the work immediately and investigate your claim.

# Secondary Voltage Control for Harmonics Suppression in Islanded Microgrids

Xiongfei Wang, Josep M. Guerrero, *Senior Member, IEEE*, Frede Blaabjerg, *Fellow, IEEE*, and Zhe Chen, *Senior Member, IEEE*

**Abstract**—This paper proposes a secondary voltage waveform control approach to suppress harmonics in islanded microgrids. Compared with the secondary control for traditional large power systems, the proposed control scheme can regulate the voltage waveform instead of voltage magnitude of sensitive buses in islanded microgrids. In addition to the centralized controller for fundamental frequency voltage component, a selective harmonic compensator is implemented in the secondary voltage control system. With the help of Park transformation, the cyclic references generated by the selective harmonic compensator passed through a low-bandwidth communication system to each primary control system for distributed generation units. Thus, combined with the high-bandwidth local voltage controllers in the primary control systems, harmonic voltage distortions in islanded microgrids are redistributed and reduced. Simulations are performed to validate the effectiveness of the proposed control approach.

**Index Terms**—Microgrid, hierarchical control, secondary voltage control, harmonic voltage distortion

## I. INTRODUCTION

THE electrical grid is moving towards a more decentralized and intelligent network, driven by the growing environmental concerns and the energy security, along with the fast technology progress in distributed generation (DG). Instead of traditional centralized electrical power production, the new electrical grid, also named as smart grid, will be more consumer-interactive and flexible. This radical transformation of electrical grid imposes severe challenges on the architecture of power systems. Therefore an urgent need exists to develop new conceptual models to undertake the increasingly complex operations [1].

The microgrid paradigm, among other envisaged models, is emerging as an attractive solution for the architectures of future grids. Microgrids, interconnecting several customers to multiple DG and energy storage units, can form intentional and non-intentional energetic islands in distribution networks, thus offering high efficient and security of

electricity services [2]. However, due to the proliferation of nonlinear loads, voltage distortions and the harmonic propagation along a distribution feeder have become serious problem in distribution networks. Furthermore, during the intentional and non-intentional islanding operations, the microgrid becomes much weaker and more sensitive to harmonic disturbances. Hence, the reduction of harmonic voltage distortions is important for stable operation of microgrids.

Generally, the inverter-interfaced DG unit can provide ancillary services on the improvement of voltage quality in distribution networks [3]. They may operate as shunt active filters to supply a certain amount of harmonic currents to the nonlinear loads. Moreover, to suppress harmonic propagation, shunt active filters based on the harmonic voltage detection method has been proposed [4]. It allows the shunt active filter to behave as a resistor at the harmonic frequencies, thus damping out harmonic propagation. Recently, this approach was implemented in the control system of inverter-interfaced DG units in islanded microgrids [5]. Nevertheless, the performance of this scheme was deteriorated in the case of long distribution feeders [6]. A further problem was that the accuracy of harmonic current sharing is reduced when DG units are distributed with different line impedances. Several other control techniques have been presented for harmonic current sharing in islanded microgrids, but all of them are achieved at the cost of harmonic voltage distortions [7].

This paper explores the function of secondary control of microgrids, and proposes a secondary voltage waveform control approach to reduce the harmonic voltage distortion in islanded microgrids. In addition to the centralized controller for the magnitude of the fundamental voltage component [8], a selective harmonic compensator is introduced for the harmonic voltages in the proposed secondary voltage control system. This harmonic compensator selectively reduces the harmonic voltage distortions at the sensitive buses of an islanded microgrid, by adjusting the references of local voltage controllers for DG units. A high control bandwidth is therefore necessary for the local voltage controllers to follow those feedforward cyclic reference signals from the secondary control system. Moreover, the low-bandwidth communication imposes constraints on high frequency feedforward reference signals to DG units, which

---

This work was supported in part by the China Scholarship Council.

X. Wang, F. Blaabjerg, and Z. Chen are with the Department of Energy Technology, Aalborg University, DK-9220 Aalborg East, Denmark (xwa@et.aau.dk; fbl@et.aau.dk; zch@et.aau.dk).

J. M. Guerrero is with the Department of Automatic Control Systems and Computer Engineering, Technical University of Catalonia, 08036 Barcelona, Spain (e-mail: josep.m.guerrero@upc.edu).

consequently degrading dynamic performances of the secondary control system. To tackle with this problem, the proposed secondary voltage control is implemented in multiple rotating reference frames. With the help of Park transformation, those feedforward cyclic reference signals are demodulated as dc signals before passing through the communication system, and then modulated back to ac signals in each local voltage controller for DG units. Theoretical analysis and simulation results are presented to confirm the validity of this control technique.

## II. PROPOSED SECONDARY VOLTAGE CONTROL

A hierarchical control structure is becoming a standard approach for microgrid management system [8]-[10]. Similar to traditional large power systems, the hierarchical control of microgrids is organized with three levels, namely the primary, secondary and tertiary control. Fig. 1 illustrates a general structure for the hierarchical control of microgrids.

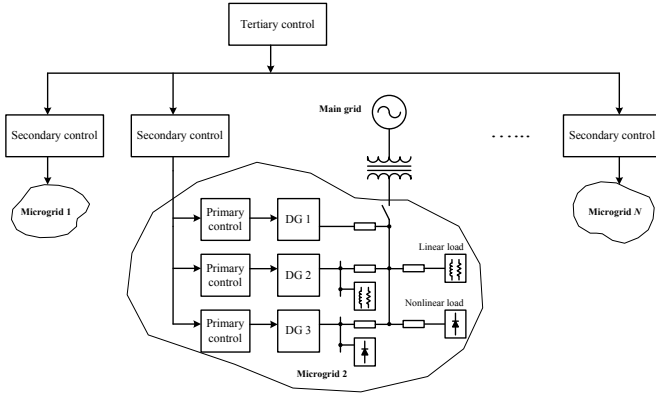

Fig. 1. The general structure for the hierarchical control of microgrids.

The primary control is implemented in the local controllers of DG units, which is responsible for the short-term active and reactive power balances. The other two levels of controls are performed by a centralized controller. The secondary control restores system frequency deviations, regulates voltage profile of sensitive buses, and resynchronizes with the main grid. The tertiary control is conceived to perform the long-term energy management tasks. The control bandwidth is gradually decreased from the primary level to tertiary level.

The secondary control plays an important role in preserving stable operations of islanded microgrids. While the secondary frequency control has been well developed [8], potential functions and operation mechanism of the secondary voltage control are still under discussions [9], [10]. Moreover, the voltage control loops of power electronic inverters have much higher bandwidth than synchronous generators, which brings new possibilities to the secondary voltage control strategies.

Instead of regulating voltage magnitude, a secondary voltage waveform control approach is proposed for reducing harmonic voltage distortions at the sensitive buses of islanded microgrids. Fig. 2 depicts the diagram of the proposed secondary voltage control scheme, where a selective harmonic voltage compensator is introduced in contrast to conventional secondary voltage magnitude controls. The second order generalized integrators (SOGI) and a frequency-locked loop (FLL) are utilized to extract harmonic voltages of interest at sensitive buses [11]. Then, the extracted harmonic voltages are compared with the harmonic voltage limits recommended by IEEE Std. 519-1992 [12]. A deadband is utilized to detect when the harmonic voltages exceed the predetermined limits.

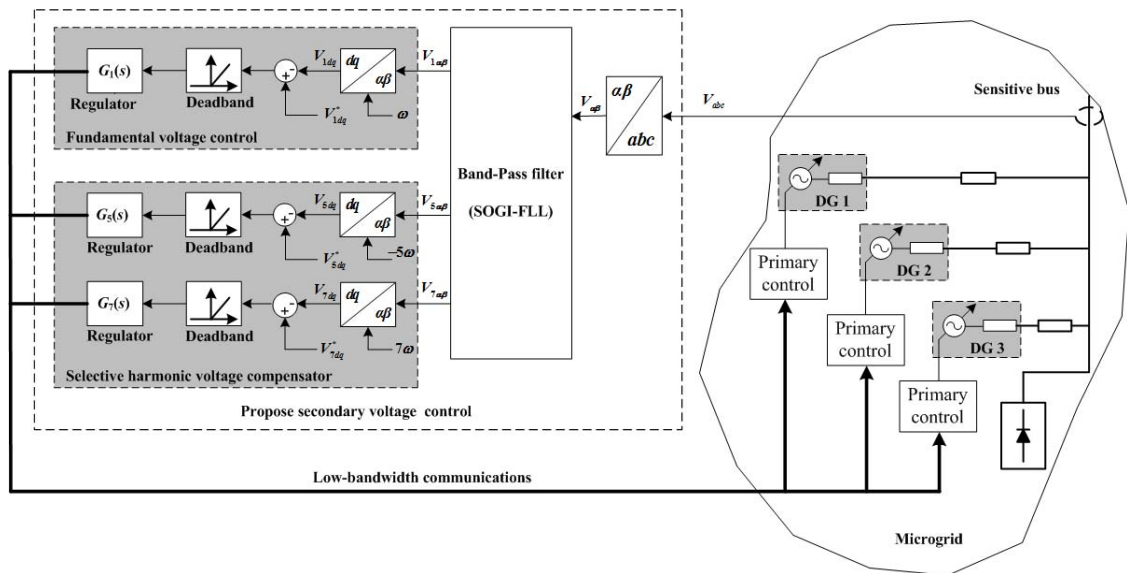

Fig. 2. The proposed secondary voltage control approach for harmonics suppression in an islanded microgrid.

Furthermore, since the outputs of the selective harmonic voltage compensator are cyclic signals with different harmonic frequencies, the use of low-bandwidth communication system tend to degrade the dynamic performance of secondary control system [13]. To overcome the constraint of communication bandwidth the selective harmonic compensator is implemented in the multiple rotating reference frames. The harmonic voltages of interest are demodulated by Park transformation as dc signals before passing through the communication system. Those dc signals are modulated back to cyclic signals in the primary control system.

In addition, to reject the disturbances caused by the local nonlinear loads of DG units, and to follow the cyclic command signals generated by the secondary voltage control, a high control bandwidth is necessary for the local voltage controllers of DG units. Fig. 3 shows in detail the diagram of a primary control system for DG unit  $N$ . Proportional plus multiple resonant integrators are adopted in the voltage controller. A virtual impedance loop is implemented for the fundamental frequency current component to alleviate the line impedance effects [7]. The participation factor  $H_N$  determines the contribution of DG unit  $N$  for reducing harmonic voltages of sensitive buses. The choice of  $H_N$  is an optimization problem under several constraints, such as the capacity of DG unit  $N$ , transmission losses and the harmonic voltage limits at the output voltage of DG unit  $N$ .

It is worth to mention that this intermediate harmonic voltage control, performed by the local voltage controllers of

DG units, provides a redistribution rather than elimination of harmonic voltage distortions in an islanded microgrid. Hence, a complete analysis on the harmonic voltage redistribution and reduction is needed for effective harmonics suppression in an islanded microgrid.

### III. HARMONIC VOLTAGE DISTORTIONS REDUCTION AND REDISTRIBUTION

The harmonic voltages in distribution systems are normally caused either by the background distortions coupled from the upstream grids or by the voltage drops resulted from the harmonic currents of nonlinear loads. Nevertheless, during islanded operation of microgrids, the harmonic voltages are mainly present due to the presence of nonlinear loads. As a consequence, the line impedance of distribution feeder and the input impedance of the nonlinear load have significant impact on the harmonic voltage distortions, and the common load bus is generally chosen as the sensitive bus of islanded microgrids.

Fig. 4 depicts a simplified one-line diagram of an islanded microgrid. Two inverter-interfaced DG units are connected in parallel through a common load bus. A three-phase diode rectifier load is considered as the nonlinear load, which mainly results in a negative fifth and positive seventh harmonic voltage.

Since the focus here is on discussing the secondary voltage control strategies, the influences of intermittent prime energy sources will not be involved and the sufficient dc-link of DG inverters are assumed for the sake of simplicity. Fig. 5 shows

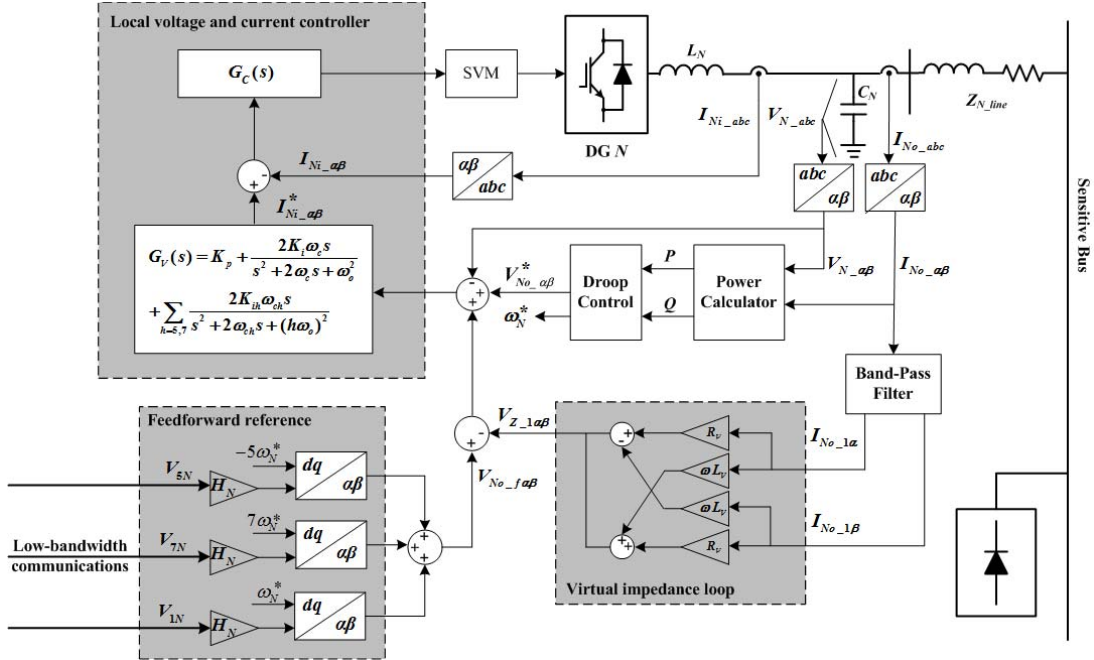

Fig. 3. The primary control system for DG unit  $N$ .

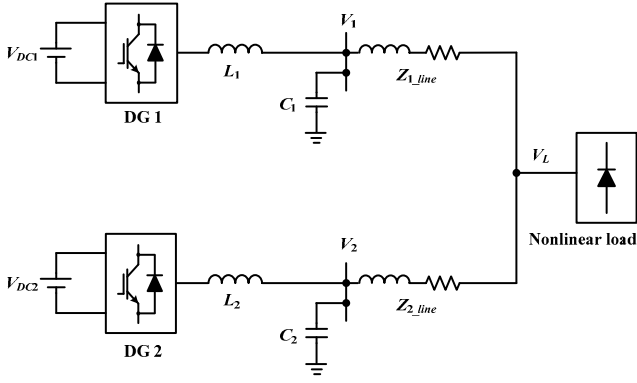

Fig. 4. A simplified one-line diagram of an islanded microgrid.

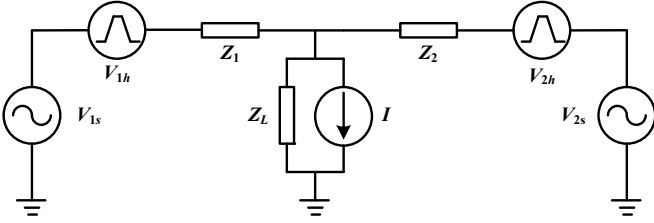

Fig. 5. Equivalent circuit of an islanded microgrid.

a per-phase equivalent circuit of the microgrid based on the proposed secondary voltage control scheme, as shown in Fig. 5. A Norton equivalent model is derived for the three-phase diode rectifier load. The influences of the line impedances of distribution feeders and the input impedances of the nonlinear loads are analyzed in detail as follows.

#### A. Redistribution of Harmonic Voltage Distortions

Fig. 6 shows simplified equivalent circuits of the microgrid at the  $n$ th-order harmonic frequency. Two operating scenarios of the microgrid are analyzed and compared. The necessity of harmonic voltage redistribution rather than elimination is presented.

In the first case where the proposed secondary voltage control is absent, the harmonic voltages of interest at the outputs of DG units are eliminated by high-bandwidth local voltage controllers. Hence, the output of DG units can be seen as short-circuited at the  $n$ th-order harmonic frequency, as shown in Fig. 6. The  $n$ th-order harmonic voltage at the common load bus  $\dot{V}_{Lnh}$  is given by

$$\dot{V}_{Lnh} = \frac{-\dot{I}_{nh}}{Y_{1nh} + Y_{2nh} + Y_{Lnh}} \quad (1)$$

$$\dot{I}_{nh} = \dot{I}_{1nh} + \dot{I}_{2nh} + \dot{I}_{Lnh} \quad (2)$$

where  $\dot{I}_{1nh}$  and  $\dot{I}_{2nh}$  are the  $n$ th-order harmonic currents drawn by the DG unit 1 and DG unit 2, respectively. The  $\dot{I}_{Lnh}$  represents the equivalent  $n$ th-order harmonic current source

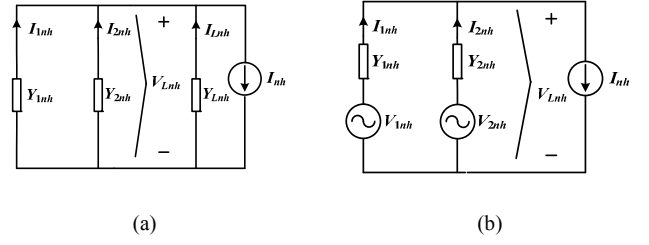

Fig. 6. The simplified equivalent circuits of the microgrid at the  $n$ th-order harmonic frequency. (a) Before applying the proposed method. (b) After applying the proposed method.

of the nonlinear load.  $Y_{Lnh}$  is the equivalent input admittance of the nonlinear load at the  $n$ th-order harmonic frequency, which draws current  $\dot{I}_{Lnh}$ .  $Y_{1nh}$  and  $Y_{2nh}$  are the line admittances of distribution feeders at the  $n$ th-order harmonic frequency.

On the other hand, when the voltage harmonic elimination is adopted in the proposed secondary voltage control method, the harmonic voltage distortions at the common load bus will be eliminated. Consequently, the current drawn by the input admittance  $Y_{Lnh}$  is zero, and the rectifier load will be equivalent as a harmonic current source, as shown in Fig. 6.

$$\dot{V}_{Lnh} = 0 \quad (3)$$

$$\dot{I}_{nh} = \dot{V}_{1nh} Y_{1nh} + \dot{V}_{2nh} Y_{2nh} \quad (4)$$

where  $\dot{V}_{1nh}$  and  $\dot{V}_{2nh}$  are the controlled  $n$ th-order harmonic voltages at the outputs of DG unit 1 and DG unit 2, respectively. Since the relationship between the voltages  $\dot{V}_{1nh}$  and  $\dot{V}_{2nh}$  can be expressed as

$$\dot{V}_{1nh} = \frac{H_1}{H_2} \dot{V}_{2nh} \quad (5)$$

where the  $H_1$  and  $H_2$  are the participation factors of DG unit 1 and DG unit 2, respectively. Then, the  $n$ th-order harmonic voltages at the outputs of DG units can be given by

$$\dot{V}_{1nh} = \frac{\dot{I}_{nh}}{Y_{1nh} + \frac{H_2}{H_1} Y_{2nh}} \quad (6)$$

$$\dot{V}_{2nh} = \frac{\dot{I}_{nh}}{\frac{H_1}{H_2} Y_{1nh} + Y_{2nh}} \quad (7)$$

Compared with equation (1), it can be seen that the harmonic voltage distortions at the outputs of DG units are inevitably increased even though the harmonic voltages of interest at the common load bus is eliminated. This phenomenon is also termed as ‘whack-a-mole’ effect in [4]. Moreover, in the case

that different controlled  $n$ th-order harmonic voltages are applied for both two DG units, one of them will have more severe voltage distortions at its output. Hence, the selective harmonic elimination scheme takes no effect on the harmonics suppression of islanded microgrids. The comparator with deadband and an offset in the harmonic voltage references are necessary in the proposed secondary voltage waveform control.

### B. Influences of Distribution Feeders and Input Impedances of Nonlinear Loads

Fig. 7 shows a more simplified equivalent circuit of the islanded microgrid. A Thevenin equivalent model is derived for the parallel-connected DG units. The admittance  $Y_{Snh}$  is the short-circuit admittance at the common load bus at the  $n$ th-order harmonic frequency, which is given by

$$Y_{Snh} = Y_{1nh} + Y_{2nh} \quad (8)$$

The voltage  $\dot{V}_{Snh}$  is the equivalent voltage source, which is expressed as

$$\dot{V}_{Snh} = \frac{\dot{V}_{1nh}Y_{1nh} + \dot{V}_{2nh}Y_{2nh}}{Y_{1nh} + Y_{2nh}} \quad (9)$$

The participation factors for both DG units are assumed equal to the  $H_s$  for simplicity. Then, the voltage  $\dot{V}_{Snh}$  can also be given by

$$\dot{V}_{Snh} = \dot{V}_{1nh} = \dot{V}_{2nh} = GH_s \dot{V}_{Lnh} \quad (10)$$

where  $G$  is the gain of the  $n$ th-order harmonic voltage control loop in the secondary controller.

The voltage  $\dot{V}_{Lnh}$  can be calculated from the Fig. 7, which is expressed as

$$\dot{V}_{Lnh} = \frac{-\dot{I}_{nh}}{(1 - GH_s)Y_{Snh} + Y_{Lnh}} \quad (11)$$

Hence, to effectively reduce the harmonic voltage distortions in the microgrid, the following equations

$$|GH_s| \leq 1 \quad (12)$$

$$|1 - GH_s| > 1 \quad (13)$$

should be satisfied.

Taking into account the relationships between the magnitude of the short-circuit admittance  $Y_{Snh}$  and the magnitude of the input admittance  $Y_{Lnh}$ , two different cases are discussed. Firstly, in the case of

$$|Y_{Snh}| \gg |Y_{Lnh}| \quad (14)$$

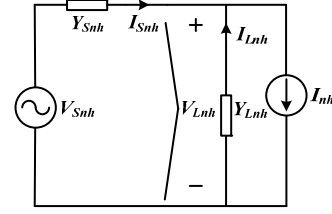

Fig. 7. Simplified equivalent circuit of the islanded microgrid.

the nonlinear load can be equivalent as a harmonic current source. Equation (14) can be rewritten as

$$\dot{V}_{Lnh} = \frac{-\dot{I}}{(1 - GH_s)Y_{Snh}} \quad (15)$$

The magnitude of  $n$ th-order harmonic voltage at the common load bus can be reduced as long as the operating conditions (12) and (13) are satisfied. On the other hand, in the case of

$$|Y_{Snh}| \ll |Y_{Lnh}| \quad (16)$$

the nonlinear load can be equivalent as a harmonic voltage source. The reduction of the  $n$ th-order harmonic voltage requires that

$$|1 - GH_s| \gg 1 \quad (17)$$

whereas the following equation can be derived based on the operating condition (12) and (13)

$$1 < |1 - GH_s| < 2 \quad (18)$$

Hence, theoretically the proposed method cannot suppress the harmonic voltage distortions in this situation. However, this case is not common in low-voltage microgrids due to the low X/R impedance ratio of distribution feeders. Furthermore, the equation (18) also gives the maximum reduction for the  $n$ th-order harmonic voltage which is less than one half of the uncompensated voltage.

## IV. SIMULATION RESULTS

To validate the effectiveness of the proposed secondary voltage control approach, simulations for the islanded microgrid shown in Fig. 4 are performed in MATLAB. A sample and hold block with 40 ms latency is utilized to emulate the low-bandwidth communication system. The main parameters for the DG inverters and distribution feeders are listed in Table I.

The harmonic analysis of three-phase diode rectifier loads has been well done in [14], [15]. The influences of the ac-inductance and the dc-inductance on the harmonic currents of

TABLE I  
MAIN PARAMETERS OF DG INVERTERS AND DISTRIBUTION FEEDERS

Equipments	Parameters	
DG inverters	Nominal frequency	50 Hz
	Nominal voltage	380 V
	Nominal power	50 kVA
	Filter inductance ( $L_1, L_2$ )	800 $\mu$ H
	Filter capacitance ( $C_1, C_2$ )	30 $\mu$ F
	DC voltage ( $V_{DC1}, V_{DC2}$ )	700 V
Distribution feeders	Symmetrical Case	$0.4 + j0.062 \Omega$
		$0.4 + j0.062 \Omega$
	Nonsymmetrical Case	$0.3 + j0.047 \Omega$
		$0.6 + j0.098 \Omega$
Three-phase diode rectifier	AC-inductance	40 $\mu$ H
	DC capacitance	2200 $\mu$ F
	DC resistance	6 $\Omega$

three-phase diode rectifiers were presented. To introduce a load current with a high harmonic content, the dc-inductance is discarded and only a small ac-inductance is used. Since the fundamental nominal input power of the rectifier is 100 kVA, the per-unit value of ac-inductance can be derived as 0.87% [14]. The harmonic spectrum for the ac current of rectifier is shown in Fig. 8.

Two different operating scenarios are tested regarding the distribution of DG units in the microgrid, namely symmetrical and nonsymmetrical situations. In the symmetrical situation the DG units are placed symmetrically and have the same line impedances, whereas in the nonsymmetrical situation the DG units have different line impedances.

#### A. Symmetrical Placement of DG Units

Fig. 9 shows the harmonic voltage spectrums in the case of symmetrical distribution of DG units. As shown in Fig. 9 a, before applying the proposed method, the fifth harmonic voltage magnitude at the common load bus exceeds 3% which is the individual voltage distortion limit [12], whereas the low-frequency harmonic voltage distortions at the outputs of DG units are almost zero due to the high-bandwidth local voltage controllers. After applying the proposed method, it is interesting to note that if only the fifth harmonic voltage is of concern, the magnitude of the seventh harmonic voltage will

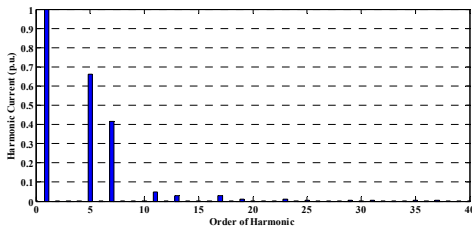
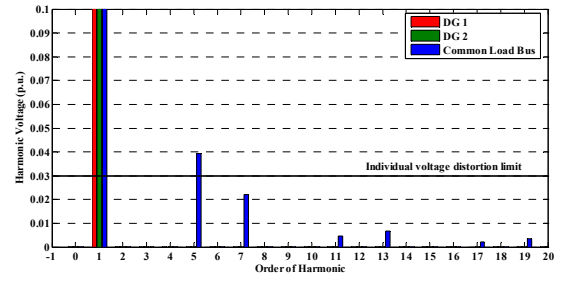
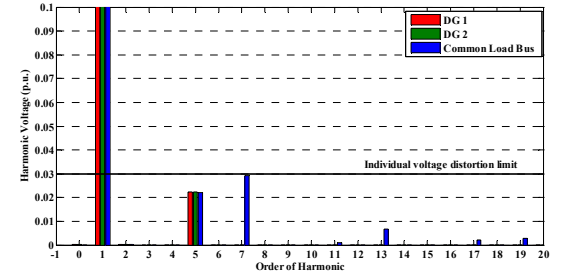

Fig. 8. The harmonic current spectrum for the three-phase diode rectifier.



(a)



(b)

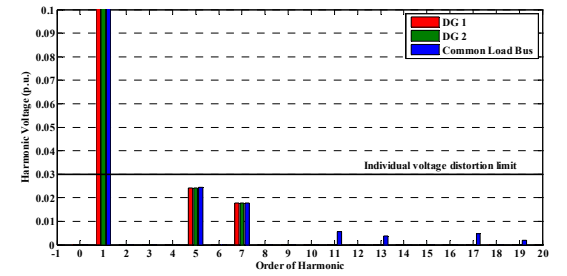

(c)

Fig. 9. The harmonic voltage spectrums in the symmetrical case. (a) Before applying the proposed method. (b) After applying the proposed method but only fifth harmonic voltage is concerned. (c) Both the fifth and seventh harmonic voltages are concerned.

increase despite the fifth harmonic voltage is decreased, as shown in Fig. 9 b. On the other hand, when both the fifth and seventh harmonic voltages are of concern, they are equally redistributed and reduced below 3%, as shown in Fig. 9 c.

Fig. 10 shows the simulation waveforms when the proposed method is applied at the instant of 1 s. The output voltages of DG units become distorted at the instant of 1 s, as shown in Fig. 10 a. This is due to the redistribution of harmonic voltage distortions. The magnitude of load current is increased at the instant of 1 s, as shown in Fig. 10 b. This is a result from the reduction of harmonic voltage distortions at the common load bus. Fig. 11 shows the magnitude changes of the fifth and seventh harmonic voltages of the common load bus, which have a good match with the Fig. 9 b and c. Hence, it is shown that the proposed method achieves a redistribution of harmonic voltages in the islanded microgrid. Also the harmonic voltages at the sensitive bus are reduced to be below the allowable limit, 3%.

### B. Nonsymmetrical Placements of DG Units

Fig. 12 shows the simulation waveforms when the proposed method is applied at the instant of 1 s. It can be seen that the difference between the voltage magnitudes of two DG units is reduced by using the virtual impedance loop for the fundamental current components. The magnitude changes of the fifth and seventh harmonic voltages at the common load bus are shown in Fig. 13. Fig. 14 shows the harmonic spectrums in the nonsymmetrical case. The voltage THD results for both symmetrical and nonsymmetrical cases are listed in Table II.

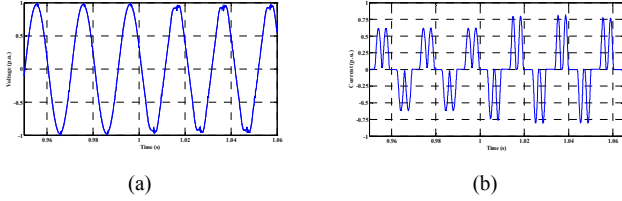

Fig. 10. The simulation waveforms for the symmetrical case when the proposed method is applying at the instant of 1 s. (a) Output voltages of DG units. (b) The harmonic current of three-phase diode rectifier

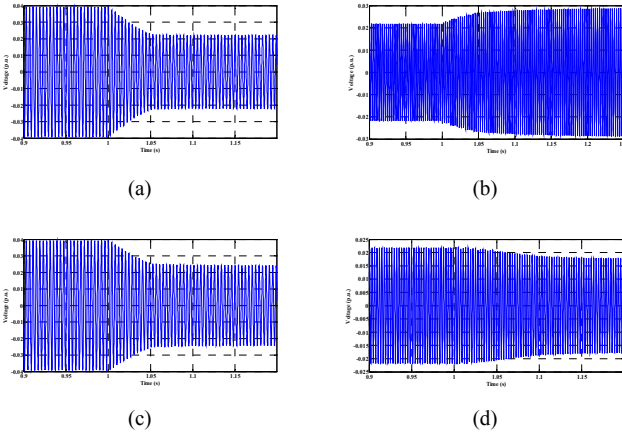

Fig. 11. The magnitude changes of the fifth and seventh harmonic voltages of the common load bus in the symmetrical case. (a) The fifth harmonic voltage when only the fifth harmonic voltage is of concern. (b) The seventh harmonic voltage when only the fifth harmonic voltage is of concern. (c) The fifth harmonic voltage when both the fifth and seventh are of concern. (d) The seventh harmonic voltage when both the fifth and seventh are of concern.

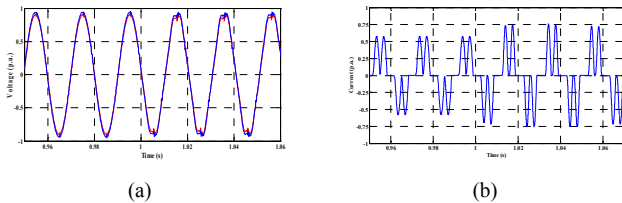

Fig. 12. The simulation waveforms of the unsymmetrical case when the proposed method is applying at the instant of 1 s. (a) Output voltages of DG units. (b) The harmonic current of three-phase diode rectifier.

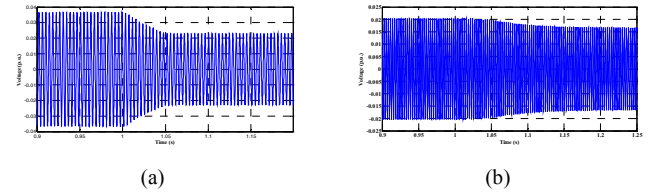

Fig. 13. The magnitude changes of the fifth and seventh harmonic voltages of the common load bus in the unsymmetrical case. (a) The fifth harmonic voltage. (b) The seventh harmonic voltage.

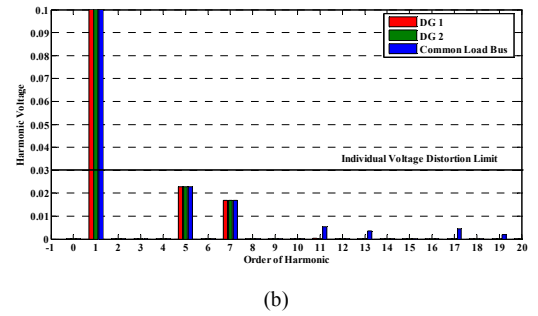
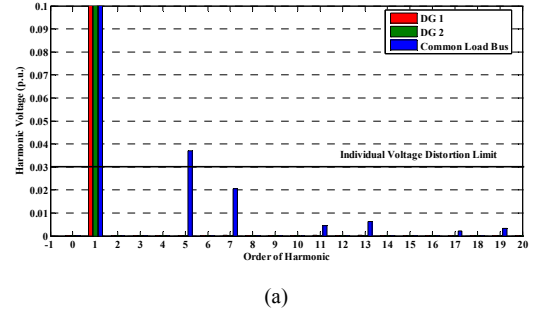

Fig. 14. The harmonic voltage spectrums in the unsymmetrical case. (a) Before applying the proposed method. (b) After applying the proposed method.

TABLE II  
VOLTAGE THD FOR DIFFERENT OPERATING SCENARIOS

Total harmonic distortions (THD) of voltage				
Operating Scenarios		DG 1 ( $V_1$ )	DG 2 ( $V_2$ )	Common load bus ( $V_L$ )
Symmetrical	Before	0.87 %	0.97 %	5.15 %
	After	3.24 %	3.28 %	3.71 %
Nonsymmetrical	Before	0.94 %	0.87 %	5.15 %
	After	3.32 %	3.41 %	3.71 %

It can be observed from the Table II that the voltage THD for the common load bus exceeds the allowable limit, 5%, before applying the proposed method. Despite that the voltage THD at the outputs of DG units are increased after applying the secondary control, the harmonic voltage distortions at the sensitive bus of the microgrid is effectively

reduced. There is a tradeoff between the voltage THDs of the DG terminals and the sensitive bus. This is due to the fact that the harmonic currents drawn by the nonlinear loads cannot be eliminated in the microgrid without using any additional active filters.

Moreover, it is important to note that the fifth and seventh harmonic voltages are redistributed equally after applying the proposed method even in the nonsymmetrical situation. This is due to the fact that this secondary voltage control provides a direct regulation on the output harmonic voltages of DG units. Hence, in contrast to the resistive shunt active filter based method [4], the proposed method can achieve effective harmonic suppression in islanded microgrids no matter whether DG units are placed symmetrically or not.

## V. CONCLUSIONS

In this paper, a secondary voltage control approach for harmonics suppression in islanded microgrids has been presented. This method is essentially a harmonic voltage redistribution process in an islanded system. The proposed scheme provides a direct way to regulate the harmonic voltages at the outputs of DG units, consequently mitigating the adverse effects of line impedances in the case of nonsymmetrical distribution of DG units. Moreover, with the help of Park transformation, the constraint of low-bandwidth communication system is overcome. The harmonic analysis and simulations based on a simple two-inverter based microgrid have been done. Finally, the results show that the proposed method is an effective add-on solution of the secondary control system for islanded microgrids.

## VI. REFERENCES

- [1] European Commission – New ERA for electricity in Europe. Distributed Generation: Key Issues, Challenges and Proposed Solutions, EUR 20901, 2003, ISBN 92-894-6262-0.
- [2] R. Lasseter, “Microgrids”, in *Proc. IEEE PES* 2002, pp. 305-308.
- [3] G. Joos, B. T. Ooi, D. McGillis, F. D. Galiana, and R. Marceau, “The potential of distributed generation to provide ancillary services” in *Proc. IEEE PES* 2000, pp. 1762-1767.
- [4] K. Wada, H. Fujita, and H. Akagi, “Considerations of a shunt active filter based on voltage detection for installation on a long distribution feeder,” *IEEE Trans. Ind. Applicat.*, vol. 38, pp. 1123-1130, Jul./Aug. 2002.
- [5] T. Lee, and P. Cheng, “Design of a new cooperative harmonic filtering strategy for distributed generation interface converters in an islanding network,” *IEEE Trans. Power Electron.*, vol. 22, no. 5, pp. 1919-1927, Sep., 2007.
- [6] M. Saito, T. Takeshita, and N. Matsui, “Modeling and harmonic suppression for power distribution systems”, *IEEE Trans. Ind. Electron.*, vol. 50, no. 6, pp. 1148-1158, Dec. 2003.
- [7] J. He and Y. Li, “Analysis and design of interfacing inverter output virtual impedance in a low voltage microgrid,” in *Proc. IEEE ECCE* 2010, pp. 2857-2864.
- [8] J. M. Guerrero, J. C. Vasquez and R. Teodorescu, “Hierarchical control of droop-controlled DC and AC microgrids—a general approach towards standardization,” in *Proc. IEEE IECON* 2009, pp. 4341-4346.
- [9] A. Mehrizi-Sani and R. Iravani, “Potential-function based control of a microgrid in islanded and grid-connected modes,” *IEEE Trans. Power Sys.* vol. 25, no. 4, pp. 1883-1891, Nov. 2010.
- [10] A. Mehrizi-Sani and R. Iravani, “Secondary control of microgrids: application of potential functions,” in *Proc. CIGRE* 2010, pp. 1-8.

- [11] P. Rodriguez, J. Pou, J. Bergas, J. Candela, R. Burgos, and D. Boroyevich, “Decoupled double synchronous reference frame PLL for power converters control,” *IEEE Trans. Power Electron.* vol. 22, no. 2, pp. 584-592, Mar. 2007.
- [12] *IEEE Recommended Practice and Requirements for Harmonic Control in Electric Power Systems*, IEEE Standard 519-1992, 1992.
- [13] M. Marwali, J. Jung, and A. Keyhani, “Control of distributed generation systems—Part II: Load sharing control,” *IEEE Trans. Power Electron.*, vol. 19, no. 6, pp.1551-1561, Nov. 2004.
- [14] S. Hansen, P. Nielsen, and F. Blaabjerg, “Harmonic cancellation by mixing nonlinear single-phase and three-phase loads,” *IEEE Trans. Ind. Applicat.*, vol. 36, pp. 152-159, Jan./Feb. 2000.
- [15] S. Hansen, L. Asiminoaei, and F. Blaabjerg, “Simple and advanced methods for calculating six-pulse diode rectifier line-side harmonics,” in *Proc. IEEE IAS* 2003, pp. 2056-2062.