



Mobile Internet Benchmarking

Skouby, Knud Erik; Tadayoni, Reza; Jost, Hugo

Publication date:
2008

Document Version
Publisher's PDF, also known as Version of record

[Link to publication from Aalborg University](#)

Citation for published version (APA):
Skouby, K. E., Tadayoni, R., & Jost, H. (2008). *Mobile Internet Benchmarking*. Center for Kommunikation, Medier og Informationsteknologi, Aalborg Universitet. <http://www.cmi.aau.dk/news/3831410>

General rights

Copyright and moral rights for the publications made accessible in the public portal are retained by the authors and/or other copyright owners and it is a condition of accessing publications that users recognise and abide by the legal requirements associated with these rights.

- Users may download and print one copy of any publication from the public portal for the purpose of private study or research.
- You may not further distribute the material or use it for any profit-making activity or commercial gain
- You may freely distribute the URL identifying the publication in the public portal -

Take down policy

If you believe that this document breaches copyright please contact us at vbn@aub.aau.dk providing details, and we will remove access to the work immediately and investigate your claim.

Managerial report Mobile Internet Benchmarking

Date: 12 September 2008

Authors: Knud Erik Skouby & Reza Tadayoni / CMI
Hugo Jost / Ascom

Contents

1. Introduction.....	3
2. Executive summary and conclusions.....	3
2.1. Definitions.....	3
2.2. Conclusions.....	4
2.3. Summary with respect to each parameter.....	4
2.4. Scope and limitations.....	7
3. Ranking of the measurement results.....	7
3.1 Ranking method.....	7
3.2 Overall Ranking.....	8
3.3 Ranking per module.....	10
4. Measurement specification.....	13
4.1 Technical Part.....	13
4.1.2 Networks under test.....	13
4.2 Route selection (Module 1 - 3).....	13
4.3 Selection of indoor locations (Module 4).....	14
4.4 Test times.....	15
Annex 1.....	16
A.1.1 Ranking method.....	16
Annex 2.....	17
A.2.1 Measurement equipment.....	17
A.2.2 Test configuration.....	17
A.2.3 Selected cities.....	18
Annex 3 Key Performance Indicators.....	19
A.3.1 IP access report.....	19
A.3.2 FTP report.....	21
A.3.3 HTTP report.....	24
A.3.4 E-mail report's (POP3 / SMTP).....	25
A.3.5 Task density.....	25

1. Introduction

On the initiative of the operator '3', center for Communication, Media and Information technologies (CMI) has performed an independent test of the coverage and capacity in 'mobile broadband' in Denmark. In cooperation with Ascom AG CMI has designed the test and Ascom has done the measurement. Four networks have been included: Sonofon, TDC, Telia and 3; a number of measurements have been in each network to test coverage and different aspects of capacity. This managerial summary provides the results of QVoice measurement data, recorded in Denmark and executed by Ascom from 5th August 2008 to 28th August 2008.

2. Executive summary and conclusions

2.1. Definitions

In each of the four networks measurements are made including the following:

- **Remote access procedure (RAS):** Measures how long it takes from opening the browser (integrated in the measurement system) till the data transmission begins. The RAS access success rate is also measured.
- **File Transfer (FTP):**
 - Up-load of 1000 kB data files from the measurement system to a server.
 - Down-load of 3000 kB data files from a server to the measurement system.

 - The following parameters are measured:
 - Average throughput per data file transfer => higher throughput results in shorter down-load / up-load time.
 - Data transfer success rate = percentage of successfully started and completed data transfers.
- **Web-page down-load (HTTP)** Down-load of the ETSI standard Webpage "Copernicus" (about 300 kB) from a server to the measurement system.
 - The following parameters are measured:
 - Average throughput per down-load => higher throughput results in shorter down-load time.
 - HTTP down-load success rate = percentage of successfully started and completed HTTP down-loads.

E-mail up-load (E-mail SMTP): Up-load of E-mails with attachment (1000 kB attachment) and without attachment from the measurement system to a server.

- We measure the following parameters:
 - Average throughput per up-load => higher throughput results in shorter down-load time.
 - E-mail up-load success rate = percentage of successfully started and completed e-mail up-loads

- **E-mail down-load (E-mail POP3)** Down-load of E-mails with attachment (1000 kB attachment) and without attachment from a server to the measurement system.
he service/
 - The following parameters are measured:
 - Average throughput per down-load => higher throughput results in shorter down-load time.
 - E-mail down-load success rate = percentage of successfully started and completed e-mail down-loads
- **Round trip delay (Round trip delay):** Measures how long it takes to send a PING-message from the measurement system to a server and back to the measurement system.

2.2. Conclusions

In the measurements outlined above we have included key technical parameters and applications to be able to benchmark the different networks' performance against each other. As summarized in section 2.3 and detailed in section 3 below, the overall test winner of this benchmarking exercise is **3** followed by TDC as number 2 based on ranking of each parameter measured.

The ranking can further be substantiated by the following composite parameters that emphasize the user experience. From the users' point of view the most important parameters are: Coverage – the access conditions; throughput – how fast do you experience the service once access is established; and the task success rate - the probability that a measurement task was successfully started and completely finished. The two first mentioned parameters are, however, seen as most important.

It requires comparable task densities for the task success rate to be counted as a an equally important benchmarking parameter.

- With respect to the coverage (including both WCDMA – 3G - and HSPDA – 'advanced 3G') **3** is best followed by TDC and much better than the other networks. Especially Telia shows a very bad WCDMA coverage and HSDPA usage. There are, however, different aspects of coverage. One aspect is the user experience of coverage being a combination of network signals, accessibility and availability – this is measured as 'task density' – here **3** is best with TDC second. The other aspect is the pure 'network signal coverage' here TDC is best followed by **3**. The user experience – the task density - is here seen as most relevant.
- Throughput in the **3** network is clearly higher than the other networks.
- With respect to the Task success rate TDC performs best; **3** is ranked as number 2.

2.3. Summary with respect to each parameter

Key Performance Indicator

RAS access

Drive Test:

Sonofon is best followed by 3 and TDC with nearly the same RAS success rate. Telia is clearly worst. In the RAS access time Sonofon and Telia show the shortest access time.

Indoor test:

In the RAS access success rate TDC clearly is best followed by 3. Sonofon and Telia are behind.

In the access time we see the same picture as in the drive test.

Remark:

A low RAS success rate results for the customer in a bad service availability.

A high RAS activation results for the customer in a longer data transmission time, but as long as the access times are in a good range (Within 2-4 seconds) the customer will not notice any differences (data transmission time = RAS access time + data transfer time controlled by throughput).

FTP

Service success rate drive test:

TDC is best followed by 3. Telia is clearly worst with a very bad task success rate.

While all the other networks show a very low dropped rate, Telia shows a very high dropped rate. This may be caused by the low throughput resulting in drops because the timeout values of the measurement are calculated for a minimum throughput of 50 kb.

Service success rate indoor test:

TDC and 3 are equal and best.

Throughput drive test:

3 clearly is best followed by TDC.

Throughput indoor test:

3 clearly is best.

HTTP

In the overall view 3 and TDC are about equal and best while Telia and Sonofon clearly perform worse. While TDC shows lower failed rate than 3, 3 shows higher throughput than TDC.

E - mail SMTP

Service success rate drive test:

3 and TDC are about equal and best.

Service success rate indoor test:

3 is best.

Throughput drive test (with 1000 kB attachment):

3 clearly shows the highest throughput followed by Telia. TDC

and Sonofon are behind.

Throughput indoor test:

3 clearly shows the highest throughput followed by Telia. TDC and Sonofon are behind.

E - mail POP3

Service success rate drive test:

TDC is best followed by 3. Telia shows a really bad success rate.

Service success rate indoor test:

TDC is clearly best followed by 3. Telia and Sonofon are about equal and clearly behind.

Throughput drive test:

3 clearly is best followed by Telia. But Telia only shows around 20% of the number of transmissions of 3 (missing coverage).

Throughput indoor test:

3 is clearly best followed by Telia.

Roaming

TDC never shows roaming.

Except TDC all the networks roamed on the bridge to Malmo to Swedish networks.

3 showed a lot of roamed calls to TDC all over Denmark.

Round trip delay (RTD)

3 and Telia are equal and best with very short RTD.

There is no direct correlation between RTD and throughput. Throughput is much more influenced by radio quality and network capacity than by RTD

Coverage

Concerning coverage (including both WCDMA – 3G - and HSPDA – ‘advanced 3G’) 3 is best followed by TDC and much better than the other networks. Especially Telia shows a very bad WCDMA coverage and HSDPA usage. There are, however, different aspects of coverage. One aspect is the user experience of coverage being a combination of network signals, accessibility and availability – this is measured as ‘task density’ – here 3 is best with TDC second. The other aspect is the pure ‘network signal coverage’ here TDC is best followed by 3. The user experience – the task density - is here seen as most relevant.

Sonofon only shows WCDMA coverage in the cities. But the city coverage of Sonofon is worse than for 3 and TDC.

At the moment Telia only seems to have WCDMA in Copenhagen, Aarhus, Odense, Aalborg, Randers and Naestved. Telia’s interworking between WCDMA and 2G works very badly;

the Telia network seems to be in a transition phase.

2.4. Scope and limitations

Statistical relevance: The number of measurements determines that the statistical relevance per module is medium. The overall statistical relevance for Denmark (sum of all modules) is medium to high.

General: As the measurements were done with modems inside a car (without any additional external antenna) the coverage conditions were very unstable. However, usage of modems inside cars without external antennas reflects real user experience and conditions are equal for all networks.

Inside the car we have to expect an attenuation of 20 - 30 dB. This reduces the covered area of a BTS by a factor of 16 (20 dB attenuation) to 100 (30 dB attenuation). In areas with small cells (cities) and good radio coverage this is not a serious problem. But in areas with big cells and bad radio coverage this attenuation results in bad quality and bad accessibility.

In major parts of the drive test routes this resulted in very bad or impossible data transmission..

3. Ranking of the measurement results

3.1 Ranking method

Because the differences between the networks are sometimes very small, we do the ranking in a „pair-wise competition“ (every operator compared against every other operator). Each won competition results in 2 points for the winner and 0 points for the loser. If we cannot separate the two results (based on the statistical deviation), both networks obtain 1 point.

Due to the statistical deviations of the results we also have to take into account the confidence interval (CI) of the results (see appendix 1 for theoretical argumentation)

The following scoring is done:

Score 3	= sum of scores against (TDC, Telia, Sonofon)
Score TDC	= sum of scores against (3, Telia, Sonofon)
Score Telia	= sum of scores against (TDC, 3, Sonofon)

Score Sonofon	= sum of scores against (TDC, Telia, 3)
----------------------	---

The winner is the network with the highest score.

Attention:
The ranks are displayed as follows: 1+ score => (lowest value = 1, highest value = 7)

3.2 Overall Ranking

Service	KPI group	Denmark Drive				Denmark "indoor"			
		3	TDC	Telia	Sonofon	3	TDC	Telia	Sonofon
sum	RAS access success rate	4	4	1	7	4	6	3	3
sum	RAS access time	1	3	6	6	1	3	6	6
sum	Overall	5	7	7	13	5	9	9	9
FTP UL 1000 KB	Task success rate	6	6	1	3	6	6	2	2
	Throughput	7	3	5	1	7	3	5	1
FTP DL 3000 KB	Task success rate	4	7	1	4	5	7	2	2
	Throughput	7	3	5	1	7	5	3	1
HTTP "Copernicus page"	Task success rate	4	7	1	4	4	7	2	3
	Throughput	7	5	3	1	7	5	2	2
e-mail SMTP no att	Task success rate	6	6	1	3	5	5	4	2
e-mail SMTP att 1000 KB	Task statistic	6	4	5	1	5	5	5	1
	Throughput	7	2	5	2	7	2	5	2
e-mail POP3	Task success rate	5	7	1	3	5	7	2	2
	Throughput att 1000 k	7	3	5	1	6	3	6	1
RTD	round trip delay	6	4	5	1	5	5	5	1
sum	Task success rate	31	37	10	18	30	37	17	12
sum	throughput	41	20	28	7	39	23	26	8
sum	Overall application	72	57	38	25	69	60	43	20
SUM	Overall (RAS + application)	77	64	45	38	74	69	52	29

Remarks indoor DK:

In services 3 clearly is best followed by TDC. 3 always shows the highest throughput. The service success rates are similar for the three of the networks, but 3 is clearly behind.

Remarks drive DK:

In the services 3 is best followed by TDC. While TDC shows a bit the better service success rate 3 always shows the highest throughput. Telia and Sonofon are behind.

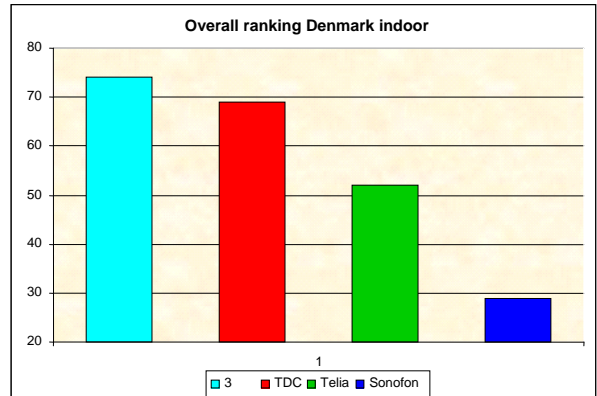
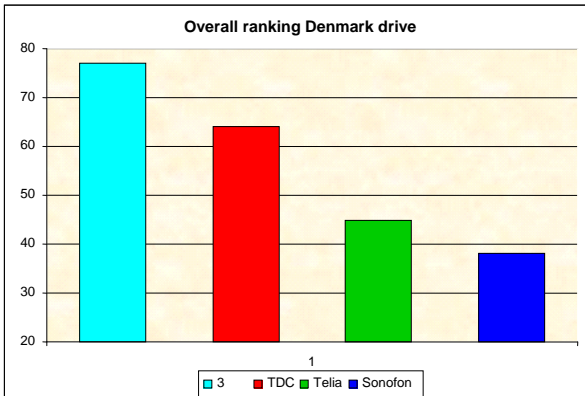
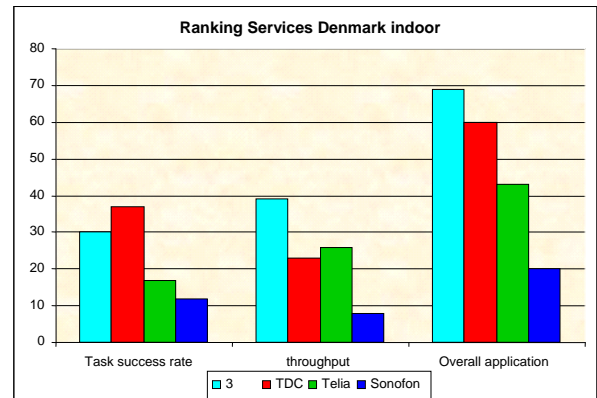
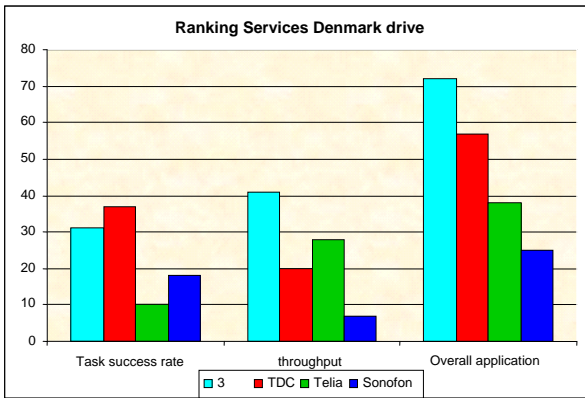
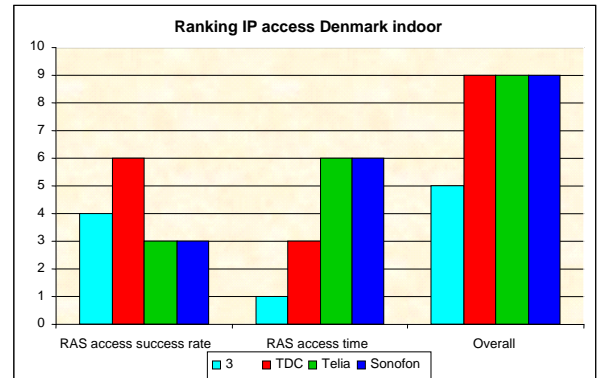
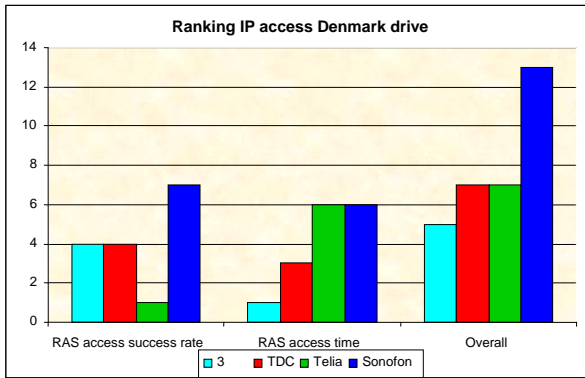

3.3 Ranking per module

Service	KPI group	top roads			
		3	TDC	Telia	Sonofon
sum	RAS access success rate	5	4	1	6
sum	RAS access time	3	1	6	6
sum	Overall	8	5	7	12
FTP UL 1000 KB	Task success rate	7	5	1	3
	Throughput	7	4	4	1
FTP DL 3000 KB	Task success rate	5	5	1	5
	Throughput	7	3	4	2
HTTP "Copernicus page"	Task success rate	5	6	1	4
	Throughput	7	5	2	2
e-mail SMTP no att	Task success rate	5	5	1	5
e-mail SMTP att 1000 KB	Task statistic	6	3	4	3
	Throughput	6	4	4	2
e-mail POP3	Task success rate	6	6	1	3
	Throughput att 1000 k	4	4	4	4
RTD	round trip delay	6	2	6	2
sum	Task success rate	34	30	9	23
sum	throughput	37	22	24	13
sum	Overall application	71	52	33	36
SUM	Overall (RAS + application)	79	57	40	48

Remarks:

In the overall ranking top roads 3 clearly is best. In the service success rate 3 and TDC are equal. But 3 always shows the highest throughput.

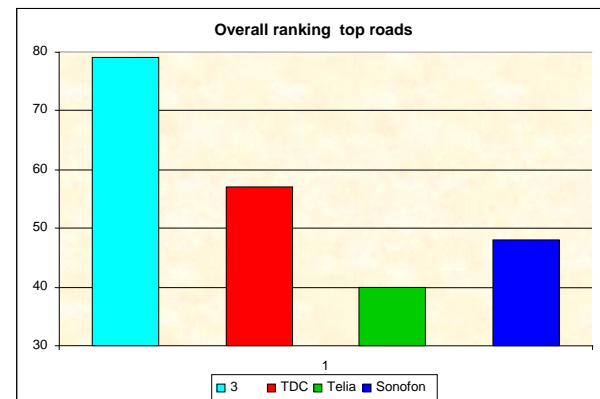
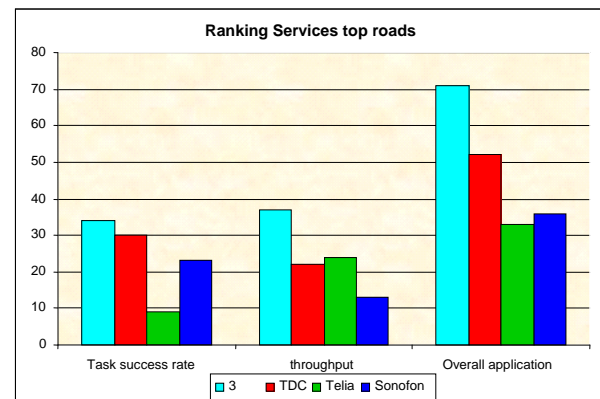
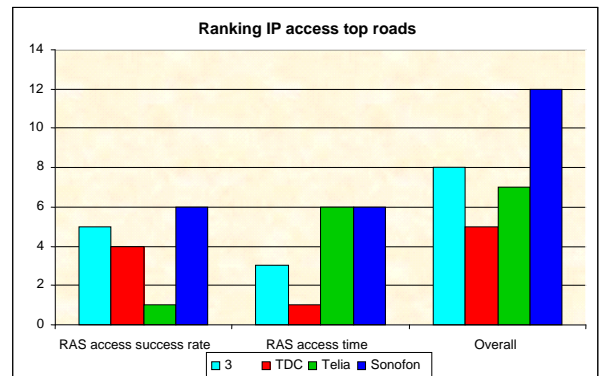

Service	KPI group	small cities			
		3	TDC	Telia	Sonofon
sum	RAS access success rate	3	6	1	6
sum	RAS access time	1	3	6	6
sum	Overall	4	9	7	12
FTP UL 1000 KB	Task success rate	5	7	1	3
	Throughput	7	3	3	3
FTP DL 3000 KB	Task success rate	4	7	1	4
	Throughput	7	4	3	2
HTTP "Copernicus page"	Task success rate	4	7	1	4
	Throughput	7	4	4	1
e-mail SMTP no att	Task success rate	6	5	1	4
	Throughput	7	2	3	4
e-mail SMTP att 1000 KB	Task success rate	5	7	1	3
	Throughput att 1000 k	7	3	5	1
RTD	round trip delay	6	4	4	2
sum	Task success rate	29	38	9	20
sum	throughput	41	20	22	13
sum	Overall application	70	58	31	33
SUM	Overall (RAS + application)	74	67	38	45

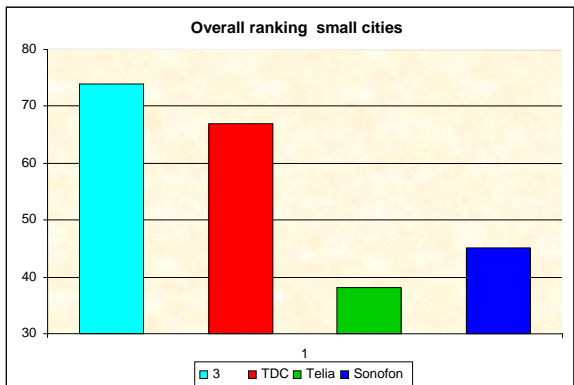
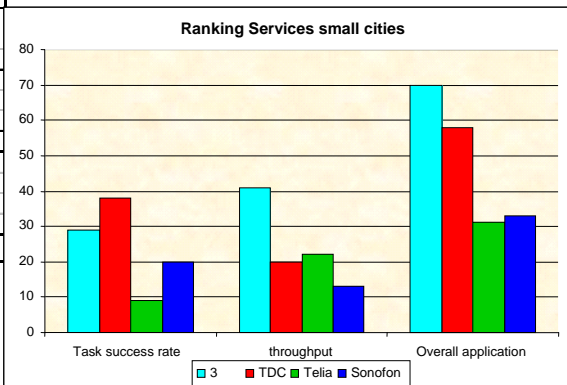
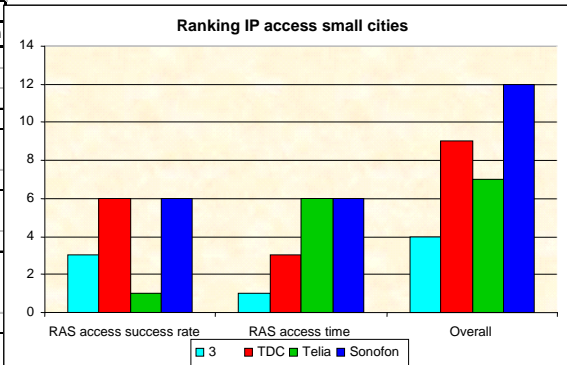

Remarks:

In the overall ranking in small cities 3 is best followed by TDC.

Service	KPI group	big cities			
		3	TDC	Telia	Sonofon
sum	RAS access success rate	6	4	1	5
sum	RAS access time	1	3	5	7
sum	Overall	7	7	6	12
FTP UL 1000 KB	Task success rate	4	6	1	5
	Throughput	7	2	5	2
FTP DL 3000 KB	Task success rate	3	6	1	6
	Throughput	7	3	5	1
HTTP "Copernicus page"	Task success rate	3	6	1	6
	Throughput	7	5	3	1
e-mail SMTP no att	Task success rate	4	5	4	3
e-mail SMTP att 1000 KB	Task statistic	5	4	4	3
	Throughput	7	2	5	2
e-mail POP3	Task success rate	4	7	1	4
	Throughput att 1000 k	7	2	5	2
RTD	round trip delay	6	3	6	1
sum	Task success rate	23	34	12	27
sum	throughput	41	17	29	9
sum	Overall application	64	51	41	36
SUM	Overall (RAS + application)	71	58	47	48

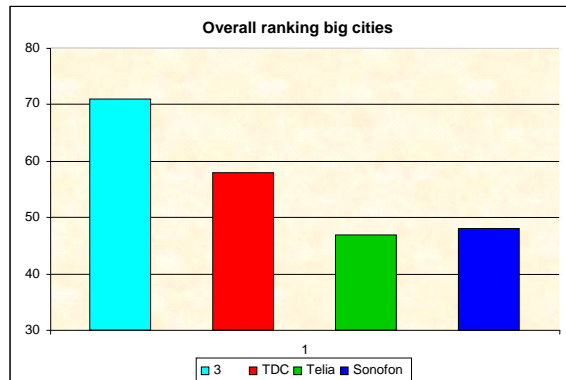
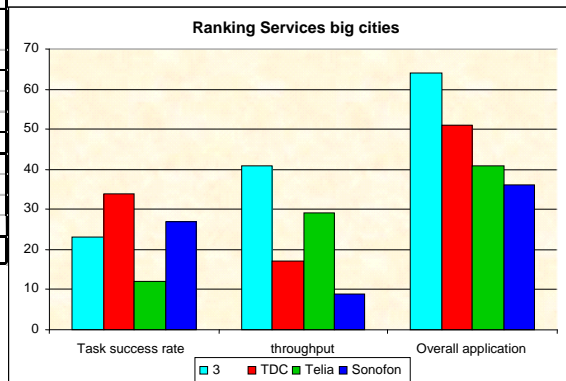
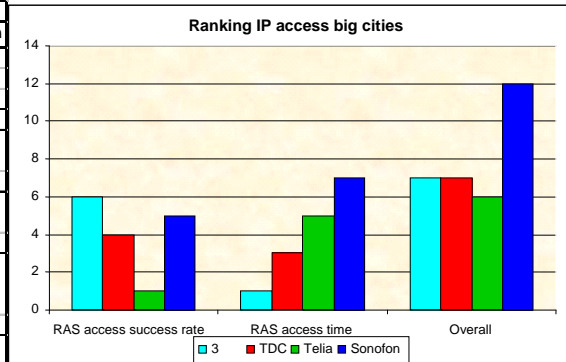

Remarks:

In the overall ranking in big cities 3 clearly is best followed by TDC.

4. Measurement specification

4.1 Technical Part

4.1.2 Networks under test

Area	Network	Network technology
DK	3	WCDMA / 2G
DK	TDC	WCDMA / 2G
DK	Telia	WCDMA / 2G
DK	Sonofon	WCDMA / 2G

4.2 Route selection (Module 1 - 3)

Since the call quality in mobile networks depends heavily on the environment and measurement conditions, three different modules are defined within this project:

M1	Top roads
M2	Small cities
M3	Big cities

To make sure that the results are comparable between the modules, each module has about the same number of measurement hours.

Within the scope of a measurement campaign, it is impossible to provide benchmarks for all roads and cities. Even for a city or town, it is not feasible to measure throughout the whole city area. Therefore, the measurements cover only a subset of roads and selected areas in cities that should be representative for each module.

As explained below, a minimum number of calls is required to achieve a certain confidence level for the investigated KPI's (Key Performance Indicators).

For the design of the measurement routes 30 – 35 measurement hours per module M3 (small cities) and M4 (big cities) have been assumed.

The measurement hours in module 1 (top roads) depend on the route length and the average drive speed.

Calculation of route length is done based on the average speed calculated for similar drive test projects.



Attention:
The bridge to Malmo is included in the drive test.

4.3 Selection of indoor locations (Module 4)

It is necessary to generate enough samples per area to get from a statistical point of view valid and stable results. (Please be aware: to get half the standard deviation we have to multiply the number of samples by 4). Because we expect a higher failure rate in indoor measurements than in drive tests we can reduce the number of measurement hours to get about the same relative standard deviation (call related values). Because we have enough sample related values, we will have only minor differences in the standard deviation of the sample based results.

All the indoor measurements are done in airports, shopping centres and railway central stations.

The measurement will be switched on outside the indoor location to get coverage from all the networks. Then we move into the indoor location and test all the networks.

Measurement areas scattered over the whole Denmark area.

Measurements are concentrated on areas with most inhabitants and calls.

Indoor tests (Module 4) will be handled in the same way as module 1-3.

All the indoor measurements will be done in stationary mode indoor at the location. Indoor in railway stations means 'waiting room'.

4.4 Test times

Because the application of voice services and different data services do not peak at the same time every day, we have done the measurements within the following time windows:

- Tests have been made on working days
 - **Monday – Friday** between 08:00 AM to 08:00 PM
 - **Saturday** between 08:00 AM to 04:00 PM
- We have almost stable load conditions within the entire time window.
- The total productive measurement time per day is about 7 - 7.5 hours randomly distributed within the time window.

Annex 1

A.1.1 Ranking method

Because the differences between the networks sometimes are very small we do the ranking in a „pair-wise competition“ (every operator compared against every other operator). Each won competition results in 2 point for the winner and 0 point for the loser. If we cannot separate the two results (based on the statistical deviation), both networks become 1 point.

Due of the statistical deviations of the results we also have to take into account the confidence interval (CI) of the results.

Values no more separated Two values are clearly separated, if the difference between mean value A and mean value B is

- greater than $[(\frac{1}{2} CI_{(95\% CL)} \text{ of value A}) + (\frac{1}{2} CI_{(95\% CL)} \text{ of value B})]$

Remarks: CI = confidence interval
CL = confidence level

If we take into account the statistical deviations based on the confidence interval for the 50% confidence level then the resulting ranking based on median values is as follows:

Calculation Competition A against B	A score	B score
$[\text{Mean A} + (\frac{1}{2} CI_{(95\% CL)} \text{ of value A})]$ < $[\text{Mean B} - (\frac{1}{2} CI_{(95\% CL)} \text{ of value B})]$ => A < B	0	+2
$[\text{Mean A} - (\frac{1}{2} CI_{(95\% CL)} \text{ of value A})]$ > $[\text{Mean B} + (\frac{1}{2} CI_{(95\% CL)} \text{ of value B})]$ => A > B	+2	0
All other cases => A and B not separated	+1	+1

Annex 2

A.2.1 Measurement equipment

The following modems were used:

3: Huawei E270
TDC mobile: Huawei E220
Telia: Huawei E220
Sonofon: Option 225

Type of equipment: The latest version of Ascom symphony measurement system with 4 data channels

Location: The Measurement system is installed in the Car in the open luggage area of a van. There are no external antennas.

Technology	Description	Operator	Band / Techn.
IP Data (Master)	1 channel Data	3	WCDMA / 2G
IP Data (Master)	1 channel Data	TDC mobil	WCDMA / 2G
IP Data (Master)	1 channel Data	Telia DK	WCDMA / 2G
IP Data (Master)	1 channel Data	Sonofon	WCDMA / 2G

A.2.2 Test configuration

FTP Tests: FTP server located in Germany, Berlin. Connected to the Internet by high speed access.

HTTP downloads: HTTP server located in Germany, Berlin. Connected to the Internet by high speed access.

E-mail SMTP:

- 3:** SMTP server 3 (smtp.3.dk)
- TDC:** SMTP server in Germany, Berlin (TDC SMTP server didn't work together with the measurement system. So we did set-up an own SMTP server for TDC)
- Telia:** SMTP server Telia (smtp.gprs-connect.dk)
- Sonofon:** SMTP server Sonofon (mail.sonofon.dk)

E-mail POP3: POP3 server located in Germany, Berlin. Connected to the Internet by high speed access.

A.2.3 Selected cities

	City/urban area	# Indoor locations	Data test hours	Test location
1	Copenhagen	<ul style="list-style-type: none"> • 1 Airport check in area terminal 3 • 2 Airport check in area terminal 1 • 3 Lyngby Storcenter, Klampenborgvej, Kgs. Lyngby • 4 Ingeniorhøjskolen, Lautrupvang 15, Ballerup 	1.5 1.5 1.5 1.5	M5-COP-1 M5-COP-2 M5-COP-3 M5-COP-4
2	Århus	<ul style="list-style-type: none"> • 1 Railway main station • 2 Vericenter, Frisenborgvej 5, 8240 Risskov 	1.5 1.5	M5-ARH-1 M5-ARH-2
3	Odense	<ul style="list-style-type: none"> • 1 Railway main station • 2 Rosengardscenter, Buchwaldsgade 35, Odense C 	1.5 1.5	M5-ODE-1 M5-ARH-2
4	Aalborg	<ul style="list-style-type: none"> • 1 Airport check in area • 2 Aalborg U.I. 20, Fibigerstaede 11-13, Aalborg 	1.5 1.5	M5-AAL-1 M5-AAL-2
5	Esbjerg	1 Esbjerg station, Jernbanegade 35, Esbjerg	1.5	M5-ESJ-1
6	Randers	1 Randers station, Jernbanegade 29, Randers	1.5	M5-RAN-1
7	Kolding	1 Kolding station, Banegardspladsen 4, Kolding	1.5	M5-KOL-1
8	Horsens	1 Horsens station, Andeas Steenbegs Plads, Horsens	1.5	M5-HOR-1

Annex 3

Key Performance Indicators Definitions and formulas

A.3.1 IP access report

RAS accessibility

Definition :

Trigger point: RAS connect request marker

RAS Attach time

Parameter range: $0 < \text{RAS attach time} < 10'000$ [ms]

Formula:

(successful attachments only)

RAS access time [ms] =

= time (RAS connect success marker) – time (RAS connect request marker)

Min: Shortest attach time

AVG: Average attach time (SUM of all set-up times / #of set-up samples)

MEDIAN: 50 % of the attach times are shorter, 50 % of the attach times are longer than the displayed

parameter.

MAX: Longest attach time

Attach statistic

Parameter range: $0 < \text{RAS access success rate} < 100$ [% RAS attempts]

Formula:

RAS access success rate [%] =

= (successful RAS attachments / all RAS attach samples) x 100

No answer count:

RAS connect procedures where no Accept/Timeout Marker was set following an RAS Connect Request

Timeout = 150 s

General remarks:

Remote access procedure starts with opening the browser resulting in accessing the network (access, authentication, DNS access).

Remote access procedure ends with successful connect to the server.

So RAS handles the whole connecting to the radio network (asking for radio resources) procedure from connecting the IP services on the WCDMA network till connecting with the remote server.

The final transmission time is: RAS + data transmission time (influenced by throughput)

Variation in PDP and RAS times is influenced by a lot of different parameters:

- Type of mobile station (USB dongles)
- Radio quality
- Round Trip delay

- Throughput in Radio network and core network
- Implementation of IP data transfer
- Response time of SGSN and GGSN
- Network load

In reality it's very difficult to find the specific differences between the networks.

But as long as the access times are in a good range (within 2-4 seconds) the customer will not notice any differences.

A.3.2 FTP report

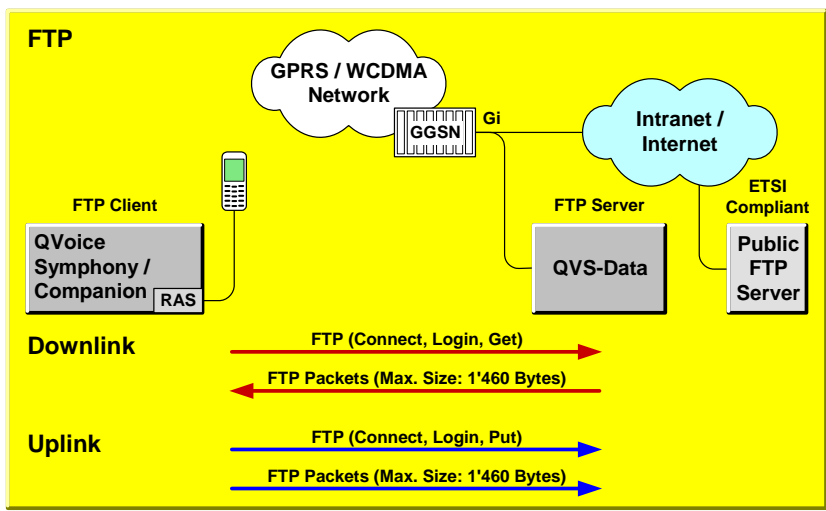

Definition : FTP file transfer upload and download

Trigger point:

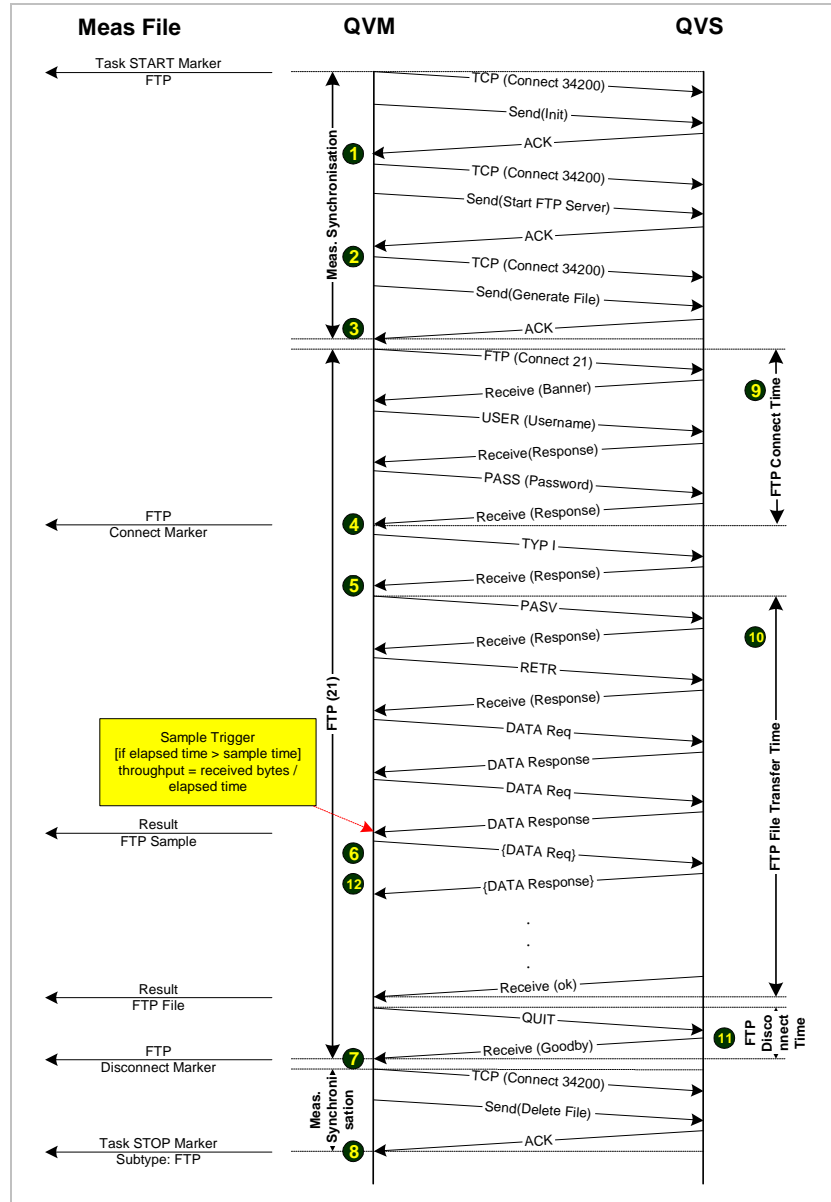

FTP file throughput: Throughput value measured per FTP file
Parameter range: $0 < \text{FTP file throughput} < \text{max. Theoretical throughput.}$

Formula: **File throughput [kbps] = FTP file transfer time / FTP file size**
(successful file transfers only)

Min: Lowest file throughput value
AVG: Average of all file throughput values
MEDIAN: 50 % of the file throughputs values are lower, 50 % of the file throughput values are higher than the displayed parameter.
MAX: Highest file throughput value

Formula: **Sample throughput [kbps] = Sample transfer time / sample size**
(successful file transfers only)

Min: Lowest sample throughput value
AVG: Average of all sample throughput values
MEDIAN: 50 % of the sample throughputs values are lower, 50 % of the file throughput values are higher than the displayed parameter.
MAX: Highest sample throughput value

FTP access statistic
Formula: **FTP failed ratio [%] =**
= (failed FTP attempts attachments / all FTP attempts) x 100

Successful: FTP connect marker received

FTP dropped statistic
Formula: **FTP dropped ratio [%] =**
= (dropped FTP connections / all successfully connected FTP) x 100

Successful: FTP disconnect marker received
Dropped reasons:

- Error GET: FTP GET failed
- Error delete: Deletion of files failed
- Error quite: Unable to disconnect FTP connection

A.3.3 HTTP report

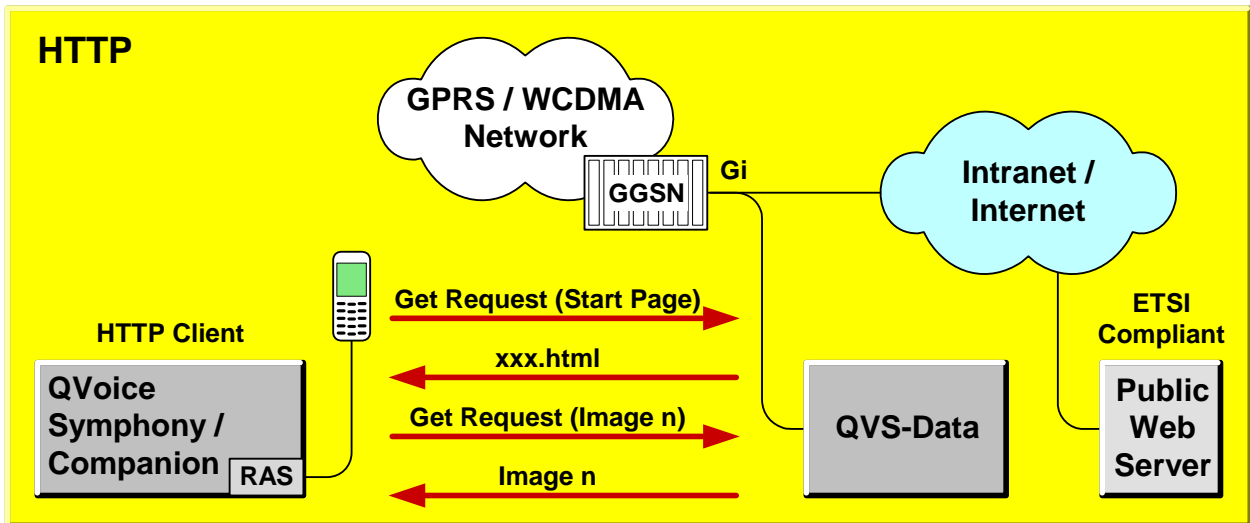

Definition :
Trigger point:

HTTP page download

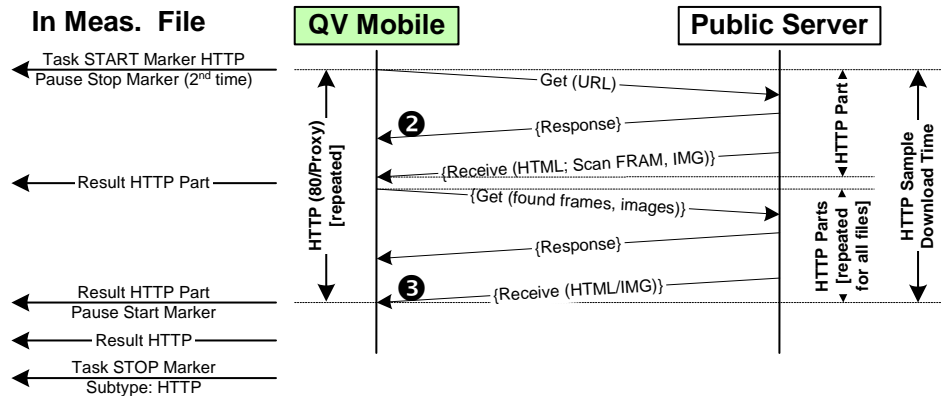

HTTP: Throughput
Parameter range:

Throughput
 0 < throughput < max. throughput

Formula:
 (successful file transfers only)

Throughput [kbps] = Page transfer time / Page file size

Min: Lowest file throughput value
AVG: Average of all file throughput values
MEDIAN: 50 % of the file throughputs values are lower, 50 % of the file throughput values are higher than the displayed parameter.
MAX: Highest file throughput value

HTTP access statistic
Formula:

HTTP failed ratio [%] =
= (failed HTTP attempts attachments / all HTTP attempts) x 100

Successful:

HTTP measurement synchronization successful

A.3.4 E-mail report's (POP3 / SMTP)

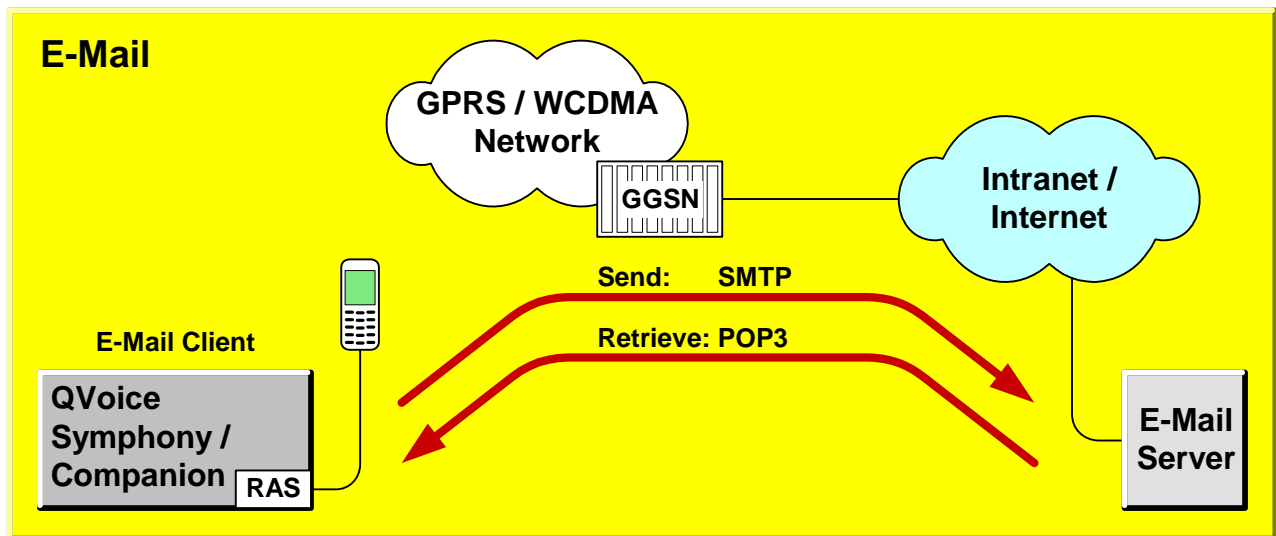

A.3.5 Task density

"Task density" shows, where (and how often) a data transmission task (FTP, HTTP, E-mail) was started.

Because a task only can be started, if the measurement system can access the network it also shows the availability of the network (WCDMA, GPRS).

Definition :
Trigger point:

E-mail POP3 / SMTP

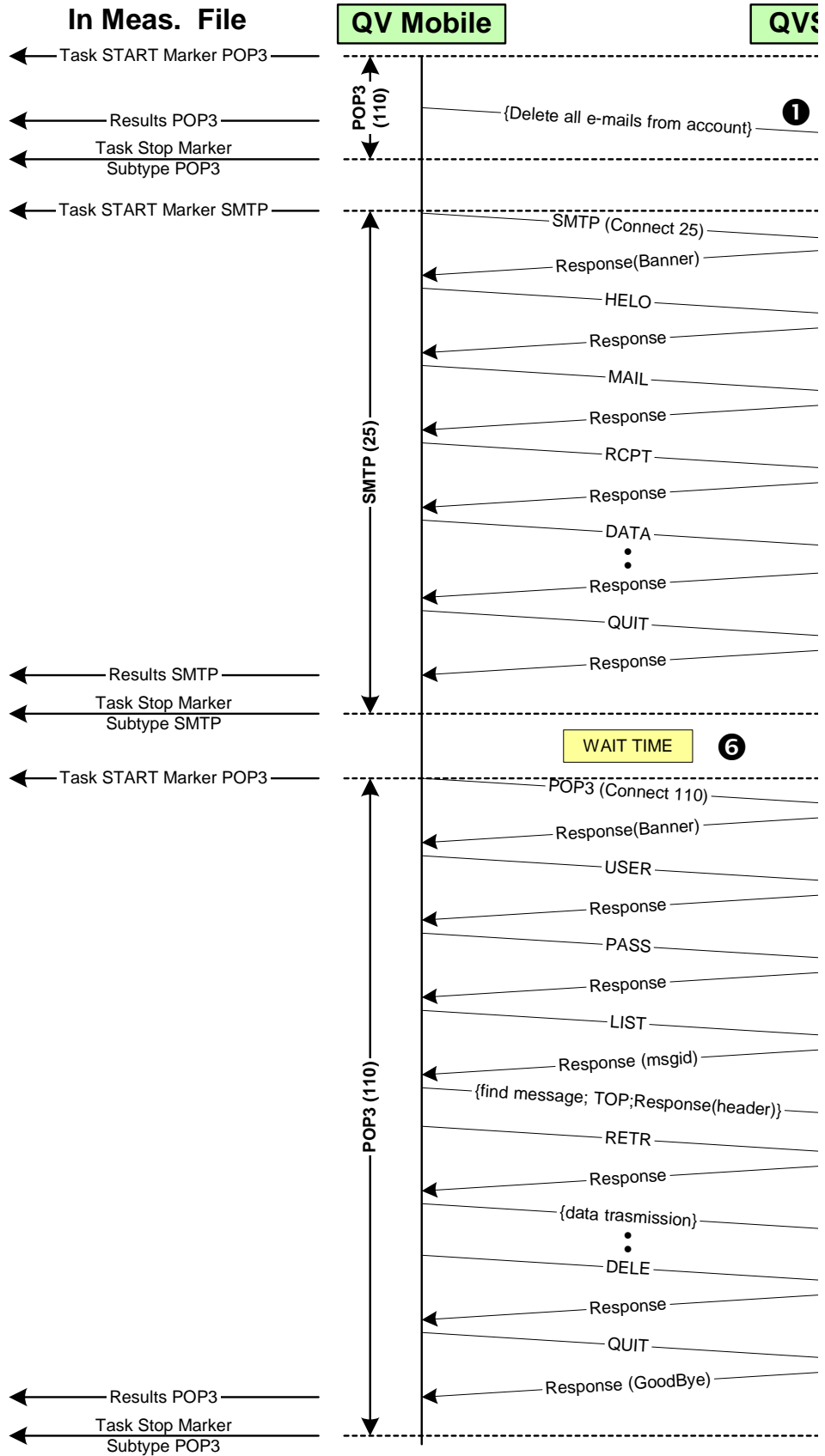

Throughput: Throughput
Parameter range: 0 < throughput < max. throughput

Formula: **Throughput [kbps] = transfer time / file size**
(successful file transfers only)

Min: Lowest file throughput value
AVG: Average of all file throughput values
MEDIAN: 50 % of the file throughputs values are lower, 50 % of the file throughput values are higher than the displayed parameter.
MAX: Highest file throughput value

Access statistic
Formula:

Failed ratio [%] =
= (failed POP3 / SMTP attempts attachments / all POP3 / SMTP attempts) x 100

Successful: POP3 / SMTP measurement synchronization successful