



Aalborg Universitet

AALBORG UNIVERSITY
DENMARK

Distance Protection of Cross-Bonded Transmission Cable-Systems

Bak, Claus Leth; F. Jensen, Christian

Published in:

Proceedings of the 12th IET International Conference on Developments in Power System Protection, DPSP 2014

DOI (link to publication from Publisher):

[10.1049/cp.2014.0001](https://doi.org/10.1049/cp.2014.0001)

Publication date:

2014

Document Version

Accepted author manuscript, peer reviewed version

[Link to publication from Aalborg University](#)

Citation for published version (APA):

Bak, C. L., & F. Jensen, C. (2014). Distance Protection of Cross-Bonded Transmission Cable-Systems. In *Proceedings of the 12th IET International Conference on Developments in Power System Protection, DPSP 2014* Institution of Engineering and Technology. I E T Conference Publication Series <https://doi.org/10.1049/cp.2014.0001>

General rights

Copyright and moral rights for the publications made accessible in the public portal are retained by the authors and/or other copyright owners and it is a condition of accessing publications that users recognise and abide by the legal requirements associated with these rights.

- ? Users may download and print one copy of any publication from the public portal for the purpose of private study or research.
- ? You may not further distribute the material or use it for any profit-making activity or commercial gain
- ? You may freely distribute the URL identifying the publication in the public portal ?

Take down policy

If you believe that this document breaches copyright please contact us at vbn@aub.aau.dk providing details, and we will remove access to the work immediately and investigate your claim.

Distance Protection of Cross-Bonded Transmission Cable-Systems

Claus Leth Bak*, Christian F. Jensen †

*Aalborg University, dept. of Energy Technology, Denmark, clb@et.aau.dk, †Energinet.dk, Denmark, cff@energinet.dk

Keywords: Cross-bonded cable systems, distance protection, impedance discontinuities, grounding resistance.

Abstract

In this paper the problems of protecting a cross-bonded cable system using distance protection are analysed. The combination of the desire to expand the high voltage transmission grid and the public's opinion towards new installations of overhead lines (OHL), more and more transmission cable systems are being laid around the world. Differential protection is often used for the main protection of cables. As a backup protection, distance protection is very often the preferred choice. Therefore, the behaviour of distance protection when applied to cross-bonded cable-systems is very interesting.

The basic assumption of a distance relay is that the measured fault impedance is linearly dependent on the distance to fault. For this to be true, the system must be fully symmetrical and only having single-ended infeed. This is not always the case for OHL-systems and never the case for a cross-bonded cable system. The fault current returning from the fault location to the source on a cross-bonded cable system can flow in all three screens and ground. This makes the system non-symmetrical and the zero-sequence compensation factor (k-factor) will not be able to describe the fault loop consistently for single phase faults any longer as the measured impedance becomes both non-linear and non-continuous with regard to the distance to fault.

1 Introduction

Distance protection relies on the proportionality between impedance measured at line end(s) and the distance to fault. For this concept to work properly, it is necessary that the measured impedance to fault location is a linear quantity, or at least that deviations from linearity are known and can be taken into account when planning the distance protection settings. Such deviations from linearity stem from many real-life applications of distance protection such as e.g. parallel lines, load transfer, impact of fault resistance and intermediate infeeds [1]. These phenomena mainly relates to EHV and UHV power transmission lines, which mainly are constructed as overhead lines. Overhead lines are very different to cable systems with respect to electrical quantities, especially when employing cross-bonding schemes, which are commonly used to lower the screen losses and thereby increasing the ampacity.

By shifting the screen regularly induced screen voltages tends towards outbalancing and thereby losses are greatly reduced. The shifting of the screen has the implication that current from one screen shifts its physical location seen from a conductor point of view, every time it reaches a cross-bonding point. Transmission cable systems are usually laid with some distance between each phase cable in order to provide proper heat dissipation for an increased ampacity.

This renders that one would expect a both non-continuous and non-linear tendency for fault impedance of such a cross-bonded cable system. The purpose of this paper is to investigate, whether conventional distance protection can be applied for such cable systems and to shed light to parameters of importance related to distance protection of cable systems. As almost all EHV and UHV cables are laid as single phase cables (except for submarine transmission cables), the single phase to shield (which is grounded) is the dominant type of fault. Therefore the Single phase-to-sheath-to-ground fault will be analysed using DIGSILENT Power factory simulation software to simulate and calculate impedance values for various cable parameters. The results presented in chapter 2 are originally developed by Christian F. Jensen in his PhD thesis [4].

2 Fault loop impedance on cross-bonded cable systems

In this section, the fault loop impedance of several cross-bonded cable systems is determined based on voltages' and currents' phasors measured at the distance relays position (line end). The purpose is to conclude which parameters are carry significance in relation to the measured fault loop impedance and thus the application of distance protection. The single core-to-sheath fault is most common, and hence, the study is focused on this type of fault.

The fault loop impedance for a single phase fault is determined based on symmetrical components as shown in Equation (1)

$$(1) \quad \underline{Z}_F = \frac{2Z_1 + Z_0}{3} \quad [\Omega]$$

where Z_1 is the positive sequence impedance and Z_0 is the zero sequence impedance of the cable system.

In order to examine the behavior in further detail and relate it to the fault location, a model of a 12 km two major section cable system with minor sections of 2 km is implemented in DIGSILENT Power Factory. The latter makes it possible to

implement full models of cross-bonded cables with use of state-of-the-art cable models and a correct representation of the sheath sequence system. The case study 165 kV single-core cable laid in flat formation and is shown in figure 1.

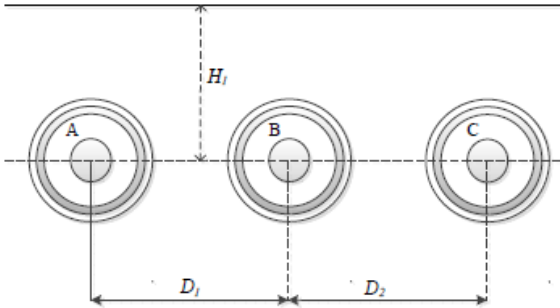

Figure 1: Flat formation 165 kV cable system with $H_f = 1.3$ m and $D_1 = D_2 = 0.4$ m

The DIGSILENT Power factory model is shown here in figure 2:

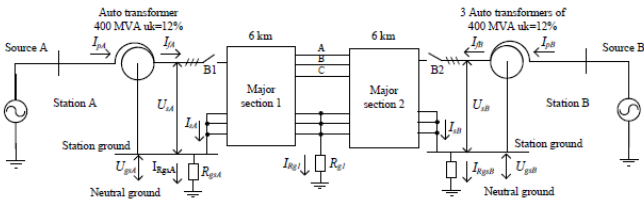

Figure 2: Power factory simulation model.

The cable model takes a physical description of the cable as input. The thickness of each layer and their electrical parameters are given, and the series impedance and shunt admittance matrix are formulated based on these. For each minor section, a distributed line model is used. The crossbonding method used in the model is presented in Figure 3.

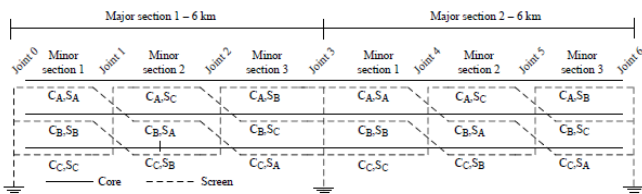

Figure 3: Cable cross-bonding scheme

The breakers B1 and B2 in Figure 2 disconnect the cable system from the respective substations, and, in general, B2 is open, so the cable system is fed only from Substation A. The equivalent resistance between the substation's grounding grid and neutral ground at Substation A and B are modeled as R_{gsA} and R_{gsB} and are set to 0.1, when both B1 and B2 are closed. If B2 is open, R_{gsB} is modeled as a field grounding resistance and together with R_{g1} , it is set to 5 Ω . The cable sheaths are bonded and connected directly at the substation's grounding grid. All impedances between the connection point of the cables and the auto transformer are neglected. At Substation

A, a single 400 MVA auto transformer with a short circuit voltage of 12 % is used, and three 400 MVA auto transformers feeding in on Terminal B with the same short circuit rating are used at Substation B. All transformers are connected to an infinite grid. The influence of the different short circuit power at Substation A and B is only affecting the results for double-sided infeed which is studied later. With these parameters, the positive and zero sequence impedances are determined for the cable as $Z_1 = 0,2132 \angle 82,7^\circ \Omega/\text{km}$ and $Z_0 = 0,1243 \angle 30,70^\circ \Omega/\text{km}$ measured from Substation A. Between core and sheath on the three phases, an ideal fault ($R_f = 0$) is applied one at the time while the fault is moved from Substation A towards Substation B. The magnitude, the angle, the real and imaginary part of the fault loop impedance measured at Substation A are all presented in Figure 4 together with the linear approximation of the fault loop impedance-based on Eq. (1).

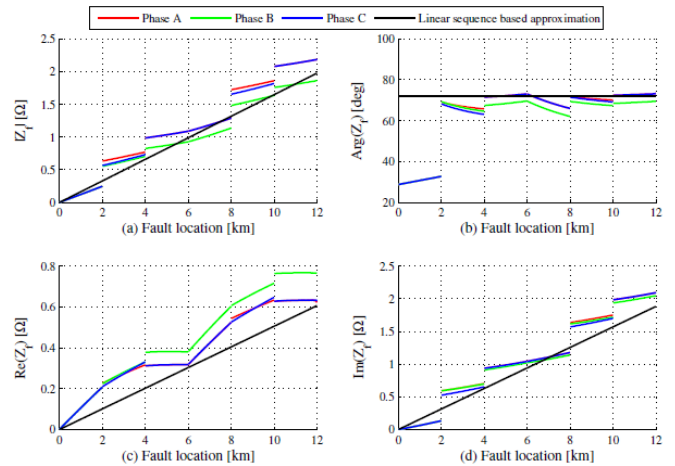

Figure 4: Fault loop impedance for a single core-to-sheath fault on a 12 km cross-bonded 165 kV cable laid in flat formation.

The discontinuities in the fault loop impedance are caused by the sudden change in the return path of the fault current when the fault shifts from one side of a cross-bonding to the next. The quite different flow of return currents for a fault at almost the same location causes a discontinuity in the fault loop impedance at the cross-bondings (2 km, 4 km, 6 km, etc.).

As the fault location is moved to the second minor section, the cable system becomes more inductive because the current loop made by the conductor and combined return path changes physical size because the sheath from another cable must carry the chief part of the return current. In addition, it is observed that the impedance of one phase is different compared to the impedance of the other two phases.

2.1 Double-sided infeed

Figure 5 shows the fault loop impedance if breaker B2 in Figure 2 is closed (double-sided infeed) while a single core to sheath fault is moved from Substation A to B. The fault resistance is set to zero, and there is no connection to ground at the fault location (the outer jacket is undamaged).

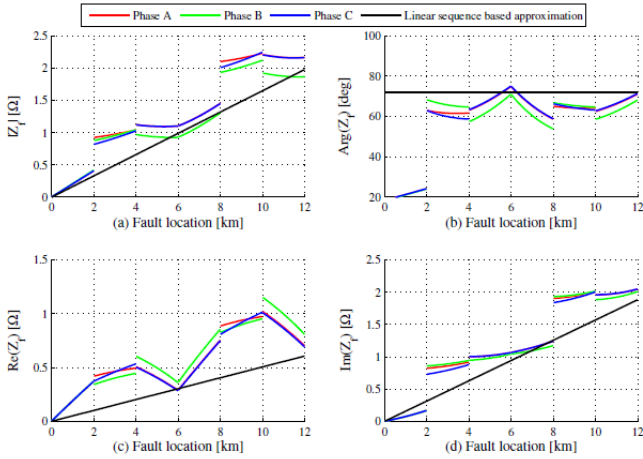

Figure 5: Fault loop impedance for a single core-to-sheath fault on a 12 km cross-bonded 165 kV cable laid in flat formation with double-sided infeed.

On an OHL-system, the fault loop impedance is not affected by double-sided infeed for single phase bolted faults [1]. Comparing Figure 5 (c) and (d) to Figure 4 (c) and (d), reveals that this is not the case for cross-bonded cable systems. The voltage drop in the fault loop is not merely caused by the current measured at the fault locator terminal, but by the current from the far-end source as well. The cable's sheaths carry return current from both sources flowing depending on the relationship between the impedance provided by the return system. The effect on the reactive part of the impedance can be either inductive or capacitive depending on the relation between the currents' angles at both terminals. This effect is similar to the 'Reactance effect' known from OHL distance protection theory and it poses complications for the correct use of distance protection schemes for EHV/UHV transmission cable systems. Detailed system studies using short circuit simulations are necessary in order to reveal over/underreach conditions for worst case situations in order to assure proper selectivity and avoid non-wanted trip conditions. On the other hand this also has to be conducted for OHL schemes, so having the knowledge of the impedance behavior for cross-bonded cable systems and proper models enables the use of distance protection for such transmission lines.

2.2 Long cables

The discrete changes in the fault loop impedance stem from the change in return path for the fault current. The relative change is larger for shorter cables. On longer systems, the influence is to some degree expected to be averaged out. The case study 165 kV cable is used to construct a 5 major sections cable with minor section of 2 km as well, which makes the total cable length 30 km. The fault loop impedance for the three phases is re-calculated for single-sided infeed, and the result is shown in Figure 6.

As anticipated, the relative impedance change is smaller for longer cables. This makes sense because the absolute change is the same for each cross-bonding point and thereby, it will

be less pronounced when compared to a "long" cable with relatively larger total impedance than its shorter counterpart. This enables an "easier" application of distance protection for such longer transmission cable lines.

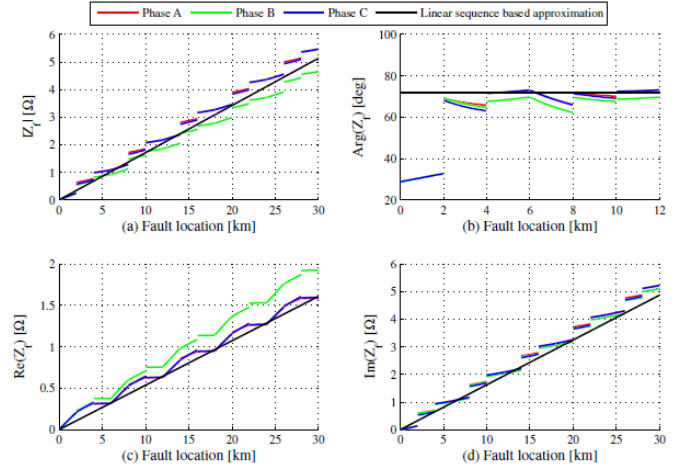

Figure 6: Fault loop impedance for a single core to sheath fault on a 30 km cross-bonded 165 kV cable laid in flat formation.

2.3 Trefoil formation

Due to symmetry, a cable system laid in trefoil will have equal mutual impedances; hence, symmetrical components can without error express the mean value of a cable's impedance. In addition, the cables are laid closer together compared to a system in flat formation. This will reduce the effect of the discrete changes in the impedance. The 165 kV case study system is placed in touching trefoil and the fault loop impedance is calculated per phase. The result is shown in Figure 7. The fault loop impedance between the phases becomes equal due to equal mutual coupling as expected. Since the size of the current loop still changes abruptly when the sheaths are transposed, discontinuities are still observed, a problem unique for cross-bonded cables.

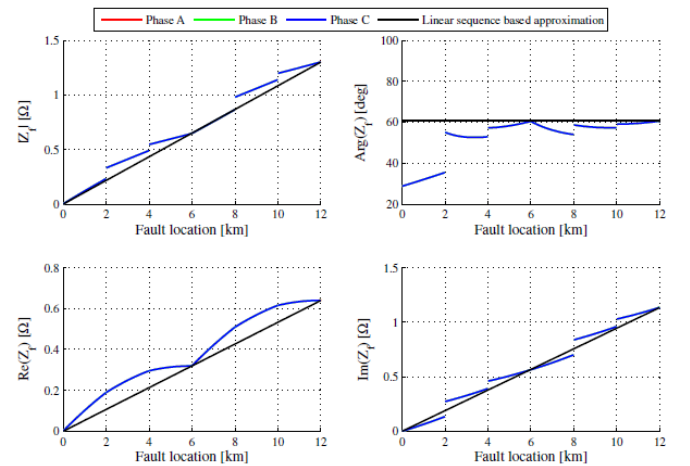

Figure 7: Phase fault loops impedance for a single core-to-sheath fault on a 12 km cross-bonded 165 kV cable laid in touching trefoil.

As with the long cables (sec. 2.2) distance protection can be applied and it would be easier to analyze the settings as the trefoil condition gives rise to smaller impedance steps and symmetry with regards to the impedance of each phase, thereby avoiding evaluating the results per phase.

2.4 Field- and substation grounding resistances and ground resistivity

In Figure 8, the flow of fault and return current in case of a short circuit in the second minor section of the second major section on a cross-bonded cable with single-sided infeed is shown. In addition, the figure shows the additional ground current flowing if the outer jacket is damaged and contact to the surrounding soil is established (green line).

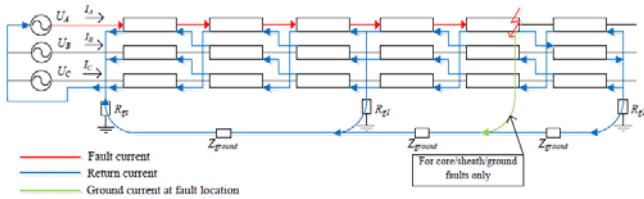

Figure 8: Fault and return current in case of a short circuit in the second minor section of the second major section of a crossbonded cable with single-sided infeed.

Moreover, in Figure 8, the distributed ground impedance is included as Z_{ground} . The ground impedance is dependent on the ground resistivity, something which can change locally and during the year. Moreover, the equivalent grounding resistance at the substation (R_{gs}) and in the field (R_{g1} and R_{g2}) will contribute to the total impedance of the corresponding return path. Therefore, variations in these can also affect the fault loop impedance. According to Cigré, the requirements for the value of grounding resistance are that the resistance should be below 20Ω [2].

The part of the fault current flowing in the ground must return to the source through the grounding resistance locally at the substation. This resistance is kept very low, but because the fault loop impedance of the cable system is also relatively low, it can have some influence, especially for faults close to the substation.

The magnitude of the fault loop impedance measured in the case study 165 kV cable system is plotted in Figure 9 (a) against the fault location and the field grounding resistance varied from 0 to 10Ω (R_{g1} and R_{gsB} in Figure 8). The substation grounding resistance R_{gsA} is set to 0 as a worst case study. The magnitude of the fault loop impedance is plotted against the fault location and the grounding resistance at the substation (R_{gsA} in Figure 8) in Figure 9 (b). The resistance which is not varied is kept constant at 0Ω as a worst case study.

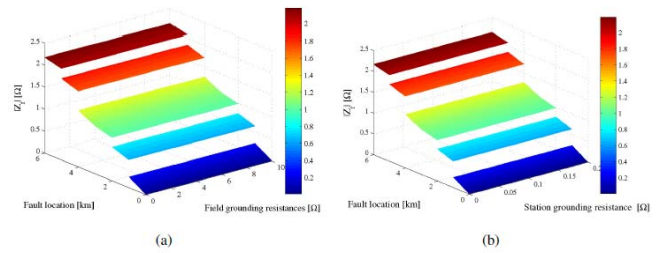

Figure 9: Magnitude of fault loop impedance as function of fault location and (a) field grounding resistance and (b) substation grounding resistance.

In Figure 9 (a) and (b), it is seen that the measured fault loop impedance is almost independent of the substation and field grounding resistances. This is because of the high impedance return path provided by the ground compared to the sheaths. Normally, the sheaths are connected directly at the substation’s grounding grid, and thus, most of the return current is flowing in the cable’s sheaths for realistic fault on cable systems. However, this is under the assumption that no metal is present near the cable system. If a metallic path parallel to the system (other cable systems, water pipes, rail road tracks, etc.) is present, it becomes quite difficult to predict the zero sequence impedance, and the latter becomes location dependent. The study of the grounding resistances show that the fault loop impedance is quite independent of the soil in which the cable system is laid as the large inductance of the ground loop combined with the grounding resistances limits the currents returning in the ground. Several factors determine earth resistivity; soil temperature, water content and type of ground. The water content and the presence of other metallic conductors are two of the main parameters which determine earth resistivity. In urban areas such as Copenhagen, Denmark, the presence of other metallic conductors is high. The fault current must, however, return close to the fault-carrying conductor due to AC-properties and only the very close metallic conductors will influence the fault loop impedance. As ground resistivity decreases, more current returns through the ground and the effect of the ground and the grounding resistances become more important. In Figure 10, we see the magnitude of the fault loop impedance as the ground resistance is varied from 5Ω to 280Ω . The substation and field grounding resistances are set to 0Ω , in order to study the full effect of the ground resistivity.

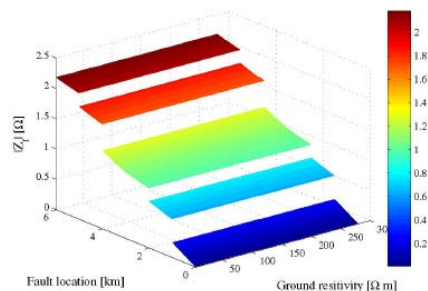

Figure 10: Magnitude of fault loop impedance as function of fault location and ground resistivity.

From Figure 10, it can be concluded that even for a low ground resistivity, a very limited amount of current will return to the source through the ground. In the case presented, the change in impedance between a ground resistivity of 5 and 280 Ω is 2.0 % at the same line. Hence, local variations in the ground resistance are of less importance provided that no parallel metallic parts are present. If so, the system changes dramatically due to the relatively much lower impedance path introduced and thus complicating the protection of cable systems.

2.5 Core to sheath to ground faults

In some cases, the outer jacket of the single core cable can be damaged, furthering the establishment of a connection to neutral ground. A part of the fault current can return to the source from this point through the ground, thus revealing an effect on the fault loop impedance measured at the fault locator terminals. It is quite difficult to model the equivalent resistance to neutral ground at the fault location, since it will depend on the local soil parameters and the extent and type of damage to the outer jacket. Figure 11 presents simulations showing the effect of a direct connection between the sheath and neutral ground ($R_{fg} = 0$) and if an equivalent resistance of 1 represents the connection. For very low values of the equivalent resistance, the connection to ground will have an influence. As the resistance increases, however, only a little current will flow to ground at the fault location and for a grounding resistance of 1, almost no current flows and the fault loop impedance is almost equal to that of a core-to-sheath fault only. In real life, a time varying fault resistance is expected [3].

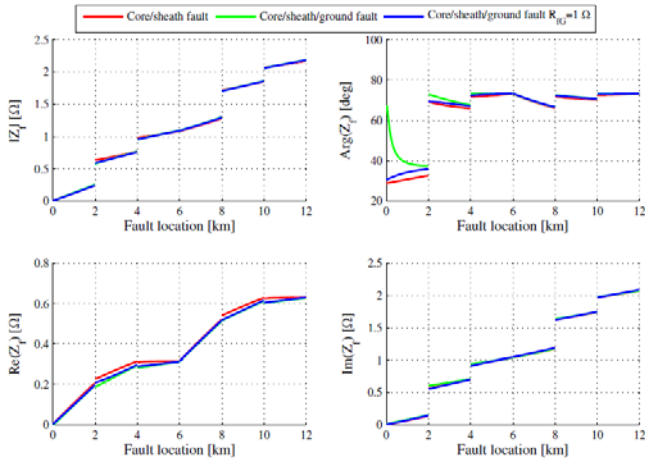

Figure 11: Fault loops impedance for a single core to sheath fault and single core to sheath fault with a connection to neutral ground of 0 and 1 on a 12 km cross-bonded 165 kV cable laid in flat formation.

2.6 Fault resistance between core and sheath

The fault resistance is time varying and can vary from close to zero to some ohms on cable systems [1]. Compared to the impedance of especially short cable systems, this resistance is

significant and can thus have a large relative effect. The imaginary part of the impedance is unaffected by the fault resistance provided that the cable is fed from a single side only – for double-sided infeed, the situation is different. Figure 12 (a) and (b) show the real and imaginary parts of the fault loop impedance because the fault resistance between core and sheath at the fault location varies from 0 to 1 with double-sided infeed.

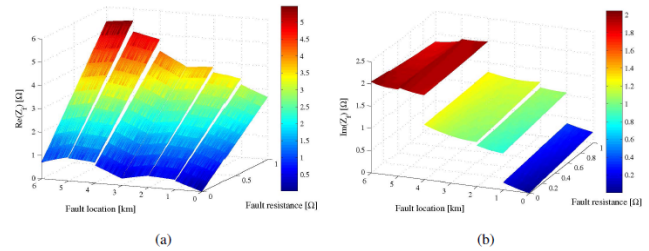

Figure 12: a) Real and (b) imaginary part of the fault loop impedance as function of fault location and fault resistance between core and sheath.

The reactance effect is especially important for cable systems even with small fault resistances as the fault loop impedance per unit length is small compared to OHLs. Hence, for distance protection to be applied for cross-bonded cables, it is necessary to find an efficient way to compensate for the influence.

3 Discussions

The fault loop impedance shows discrete changes at every cross-bonding. This is due to the change in return path for the fault current. Double-sided infeed has an effect on the imaginary part of the fault loop impedance for bolted faults on cross-bonded systems due to the common return path for the two sources provided by the sheath system. On longer cables, the effect of the discrete changes becomes less, relatively seen. For a cable system in trefoil, the fault loop impedance per phase becomes equal, but discrete changes are still observed. The fault loop impedance is not much affected by the equivalent resistance of the grounding rods in the field or by the grounding of the substation due to the large ground impedance. Therefore, if the cable model predicts the fault loop impedance well based on cable parameters, it may be possible to apply distance protection for cross-bonded cables. However, for double-sided infeed, a reactance effect is seen in the measured impedance especially for far-end faults. The effect is dominating and a compensation scheme must be implemented.

The main findings are that distance protection can be applied for most cross-bonded transmission cable systems having a realistic line length, but proper short circuit simulation studies using cable models able to describe a cross-bonded cable systems impedance variations, must be used in the design phase of the protection settings.

Acknowledgements

The authors acknowledge the long, ongoing and always very fruitful cooperation with Danish transmission system operator Energinet.dk

References

- [1] Gerhard Ziegler, Numerical distance protection, third edition, Siemens 2008.
- [2] Cigré Study Committee 21. The Design of Specially Bonded Cable Systems. Electra No. 28, Cigré, 2011.
- [3] B. Koch. Tests on xlpe-insulated cable arcing faults and arc-proofing. Power Delivery, IEEE Transactions on, 3(4):1289–1295, 1988.
- [4] Christian F. Jensen, PhD thesis ” Online Location of Faults on AC Cables in Underground Transmission Systems”, Aalborg University, 2013.