



Aalborg Universitet

AALBORG UNIVERSITY
DENMARK

Modelling and Simulation of VSC-HVDC Connection for Wind Power Plants

Chaudhary, Sanjay Kumar; Teodorescu, Remus; Rodriguez, Pedro; Kjær, P.C.; Christensen, P. W.

Published in:
Proceeding of the 5th Nordic Wind Power Conference

Publication date:
2009

Document Version
Publisher's PDF, also known as Version of record

[Link to publication from Aalborg University](#)

Citation for published version (APA):
Chaudhary, S. K., Teodorescu, R., Rodriguez, P., Kjær, P. C., & Christensen, P. W. (2009). Modelling and Simulation of VSC-HVDC Connection for Wind Power Plants. In Proceeding of the 5th Nordic Wind Power Conference: Power System Integration and Electrical Systems of Wind Turbines and Wind Farms

General rights

Copyright and moral rights for the publications made accessible in the public portal are retained by the authors and/or other copyright owners and it is a condition of accessing publications that users recognise and abide by the legal requirements associated with these rights.

- ? Users may download and print one copy of any publication from the public portal for the purpose of private study or research.
- ? You may not further distribute the material or use it for any profit-making activity or commercial gain
- ? You may freely distribute the URL identifying the publication in the public portal ?

Take down policy

If you believe that this document breaches copyright please contact us at vbn@aub.aau.dk providing details, and we will remove access to the work immediately and investigate your claim.

Modelling and Simulation of VSC-HVDC Connection for Wind Power Plants

S. K. Chaudhary^{#1}, R. Teodorescu^{#2}, P. Rodriguez^{*3}, P. C. Kjær^{^4}, P. W. Christensen^{^5}

[#]*Department of Energy Technology, Aalborg University
Pontoppidanstraede 101, Aalborg 9220, Denmark*

¹skc@iet.aau.dk

²ret@iet.aau.dk

^{*}*Department of Electrical Engineering
Technical University of Catalonia, Spain*

³prodriquez@ee.upc.edu

[^]*Vestas Wind Systems A/S,*

Denmark.

⁴pck@vestas.dk

⁵pewch@vestas.dk

Abstract— This paper describes the modelling and simulation of offshore wind power plants (WPP) connected to the onshore power system grid by VSC based HVDC transmission. Offshore wind power plant is modelled with several wind turbine generators connected to two separate collector buses with their own plant step-up transformers. VSC's are modelled using ideal IGBT switches supplied by the gate pulses from their respective controllers.

A sequence of operation has been simulated from the starting up of the VSC-HVDC transmission, energizing the offshore grid and subsequent synchronization of the individual wind turbines. Simulation of power ramping up and down as well as steady state operation has been demonstrated. As an additional case, the primary reserve control logic has been implemented and simulated in PSCAD model.

I. INTRODUCTION

Wind power plants (WPP) have come a long way from isolated wind turbines to clusters of large wind turbines of a few MW power sizes. Now WPP is regarded as a viable and competitive source of renewable energy. By the end of 2008, total installed capacity of WPP reached above 120.8 GW in the world; out of this nearly 66 GW has been installed in Europe, mostly onshore WPP's[1]. Due to scarcity of onshore sites, developments in offshore technologies and availability of a better aerodynamic profile, the trend in Europe is to develop large offshore WPP. By 2030, Europe expects to have 300GW of wind energy, out of which 120GW is expected from Offshore WPP[2].

A WPP comprises of a large number of wind turbine generators (WTG's) connected together at the collector bus. Each WTG has a wind turbine with drive train assembly for driving the generator. The generator may be directly

connected squirrel cage induction machine running at a fixed speed, or a doubly fed induction generator which can allow 25-30% speed variation or a synchronous machine with full scale converters.

While variable speed induction generators provide a flexible coupling to the grid, synchronous machine has a stiff coupling to the grid as it can run only at synchronous speed. Such a stiff coupling between the generator and the grid is undesirable in wind turbine generator as the transient torques produced in the shaft causes significant mechanical stress on the gears [3]. Full scale converters can decouple the synchronous machine speed from the grid frequency and thus enable flexible operation over a wide range of speed. The present paper assumes synchronous generators with full converters, though it is equally applicable for any other generator using full power rated converters.

VSC-HVDC transmission is a favorable transmission technology in view of its numerous advantages like use of extruded polymer insulated DC submarine cables, fast control of active and reactive power, experience with offshore installations, ability to connect to weak and passive grids etc.[4]. BorWin1 offshore wind-farm in the North Sea will soon be connected to the grid by VSC-HVDC transmission [5].

This paper describes the modelling and simulation of a WPP with a large number of wind turbine generators and connected to the grid by VSC-HVDC transmission. Section II presents the system outline and modelling details. In Section III, simulation of a sequence of operations is described. Section IV presents a method of relaying onshore grid frequency to the offshore grid through VSC-HVDC link. Finally the paper is concluded in section V.

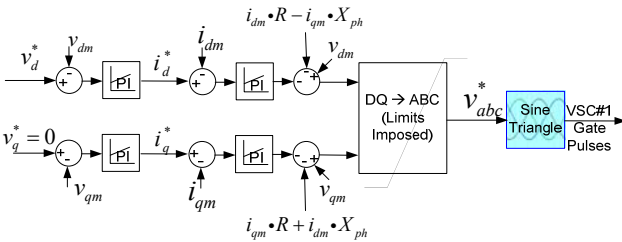
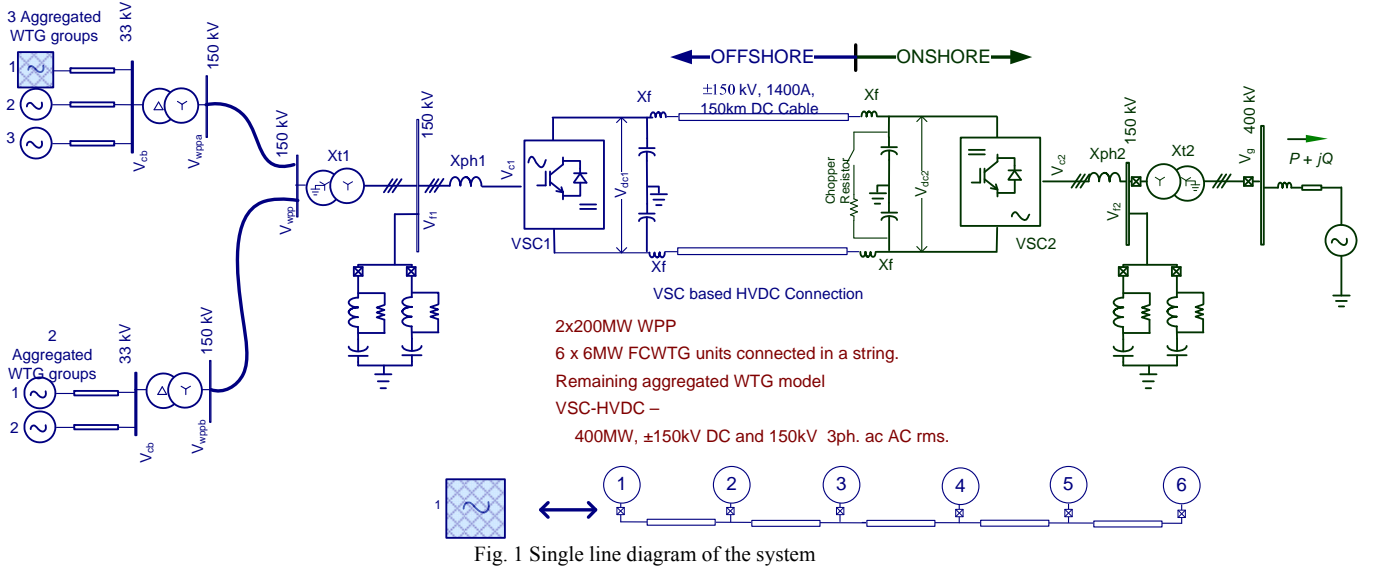

behind impedance is used to represent the onshore grid, while the HVDC has been modelled in detail with switched converters and their controller, converter transformers, phase reactors, filters and DC capacitors, HVDC cable, DC line reactors. The assumed system data is given in the Appendix.

Modelling of the VSC controllers and the WTG is described in the following sub-sections.

A. Offshore VSC Controller

The offshore VSC controller (VSCC1) controls the offshore grid voltage and frequency. The desired voltage reference is set to the d-axis voltage control loop while the q-axis voltage reference is set to 0. The rotating reference frame is selected such that the voltage phasor is aligned with the d-axis. Current references are generated from these AC voltage controllers in the outer loop. The inner loops produce the reference voltages which are augmented by the feed-forward of the voltage at the filter bus and compensation for the drop in the phase reactor [6]. Pulse width modulation (PWM) signals are generated using sine-triangle comparison as shown in Fig. 2.

Fig. 3 Block Diagram of Onshore VSC Controller

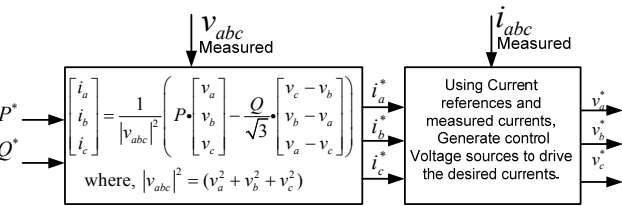

B. Onshore VSC Controller

The onshore VSC controller (VSCC2) regulates the HVDC voltage and the reactive power (or terminal voltage) exchanged with the onshore grid as shown in Fig 3. The HVDC voltage regulation loop sets the d-axis current reference while the reactive power is controlled by setting the q-axis current reference. These are controlled by the inner current loop controls as described in the previous section [6].

The reactive power control loop may be switched in the voltage (at PCC) control mode. Then the sensitivity of the PCC voltage with respect to the reactive power injection is used to determine the q-axis current reference.

Fig. 4 Determination Voltage Source model for WTG with FSC

I. SYSTEM DESCRIPTION AND MODELING

Fig 1 shows a single line diagram of the system being studied. A simple Thevenin's equivalent voltage source

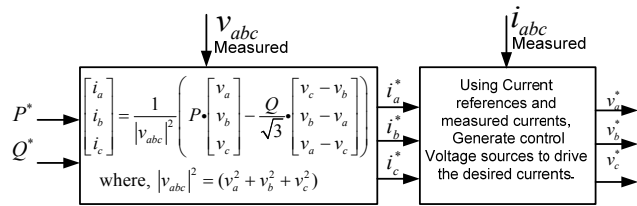

C. WTG with FSC model

Every WTG is assumed to be equipped with its own FSC. In this simulation study the WTG with its FSC is modeled as a current controlled voltage source. As shown in Fig. 4, positive sequence component of the terminal voltage is estimated and then for a specified active and reactive power output, the phase currents to be injected into the offshore grid are computed. Second order generalized integrator (SOGI) based controllers then set the voltage source references to achieve the current injections.

In this study the 400MW WPP is divided into two groups of 200MW each. In one group, a string of 6x6MW WTG is modeled and the remaining units of 164MW are lumped together into two equivalent units. In the other group, 2x100MW lumped models have been used.

D. Frequency dependent power controller

Like conventional power plants WPP are expected to cater to the primary and secondary frequency control. Though this is subjected to the wind availability, WPP can be estimated to hold certain reserve capacity by not operating on the maximum power curve. The curve itself may be a function of estimated wind speed, so that the amount of spinning reserve is predictable. Since VSC-HVDC decouples the offshore grid frequency from the onshore grid frequency, there has to be some mechanism to relay the onshore frequency variations. VSC.HVDC controllers controlling the HVDC voltage and offshore grid frequency can be used for the purpose.[7].

II. SIMULATION OF OPERATIONAL MODES

A sequence of processes has to be followed so as to energize the VSC-HVDC link, and the offshore grid and synchronizing the WTG before power generation can be ramped up.

The operation range can be divided into the following sequence of operations –

- i. Charging the DC capacitors and energizing VSC-HVDC
- ii. Energizing the Offshore grid
- iii. Synchronization of offshore WTG and power control
- iv. Steady state operation at maximum P and Q output.

Fig. 5 shows the power and VSC-HVDC voltage waveforms during the whole sequence of operations.

E. Charging of VSC-HVDC

In the beginning, the VSC-HVDC as well as the offshore WPP grid is not energized. When the circuit breaker is closed to connect the converter to the grid through the converter transformer, the anti-parallel diodes in VSC2 does the rectifying action and a large inrush current flows in to charge the HVDC capacitors and the HVDC line to the DC voltage level of uncontrolled rectifiers, given by,

$$V_{dc0} = \frac{3\sqrt{3}}{\pi} V_m \quad (1)$$

However, since the offshore VSC is blocked, the diode rectifier action of the onshore VSC sees a capacitive impedance of the cable and the DC capacitors. Hence the DC capacitors and the cables get charged to the peak line to ground voltage levels, i.e. $\pm 122.5\text{kV}$ (i.e. 1pu) or 245kV pole-pole voltage. In Fig. 6, the voltage has risen to 255kV by the rectifier and boosting actions of the diodes and phase reactors.

The initial magnitude of inrush current is limited by the impedance of the grid, converter transformers and the phase reactors. In this simulation, pre-insertion resistors of $1\text{k}\Omega$ have been used for a period of 70ms.

After 200 ms, VSC2 controller is de-blocked and gate pulses are applied to the IGBT's. The HVDC capacitors and the lines then get charged to the operating voltage of the VSC-HVDC in a controlled manner. The power required for the charging and energization is drawn from the grid.

F. Energizing the Offshore grid

After the VSC-HVDC line voltage is stabilized, then the offshore VSC (VSC1) is de-blocked. Its controller ramps up the reference voltage and the offshore voltage builds up gradually. After nominal voltage level is attained in the offshore-grid, the WTG cables are connected to the collector bus one-by-one to avoid oscillations. At this point of time the WPP is fully energized, and the WTG's are ready for synchronization.

Initial charging of the VSC-HVDC and energizing of the offshore grid is shown in Fig. 6

G. Synchronization of offshore WTG and power control

The WTG's are running at rated voltage but with no load generation. The PLL in the FSC-inverter detects the magnitude and phase of the WPP grid voltage. The FSC-inverter output voltage is matched with the grid voltage at no load and then it is ready for synchronization. The breaker is closed. After that the power can be ramped up or down as per the requirement. Both active and reactive power command can be given to the FSC. While the active power comes from the WTG, VSC is capable of generating or absorbing reactive power as long as its maximum current rating is not exceeded.

H. Steady State operation

Fig 7 and 8 show the current and voltage waveforms when the WTGs are operating in steady state at no generation and at maximum power generation respectively. In Fig 7, the WPP currents are lagging the WPP voltage by approximately 90° implying that the WPP has capacitive var generation which flows towards the offshore VSC. The capacitive var generation can be attributed to the cable capacitances and the L-C-L filters. The no load ac current waveform of the onshore VSC shows the flow of 0-sequence component.

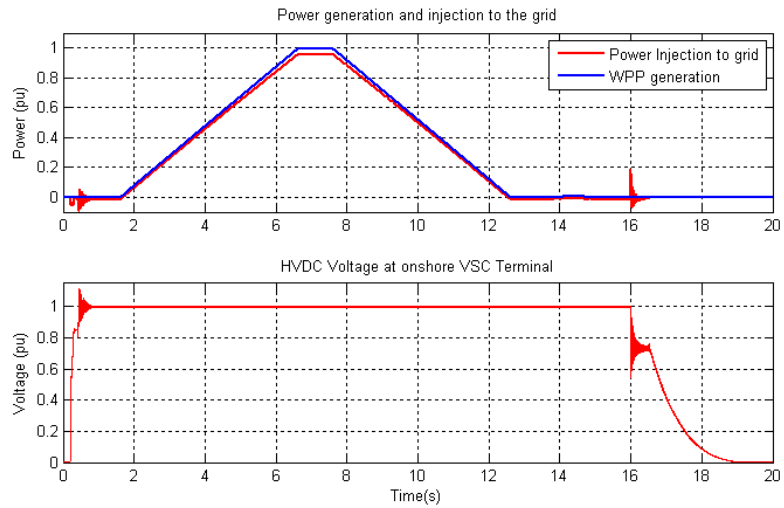

Fig. 5 WPP Power generation and injection into the onshore grid

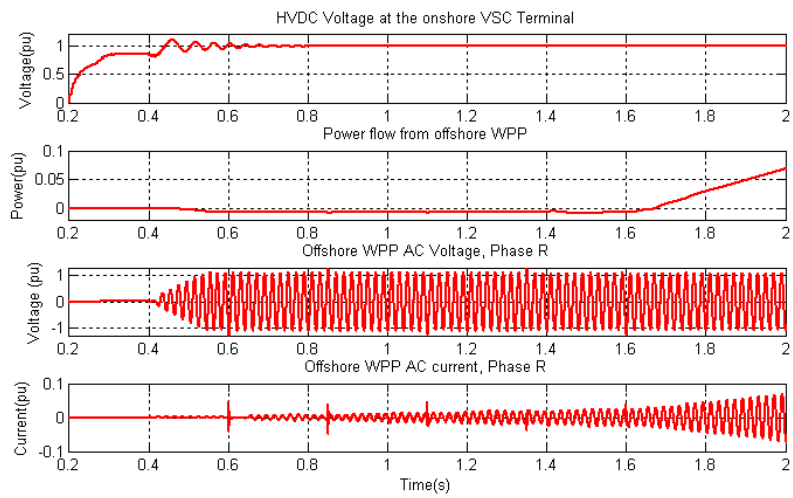

Fig. 6 Charging VSC-HVDC and energizing the offshore grid

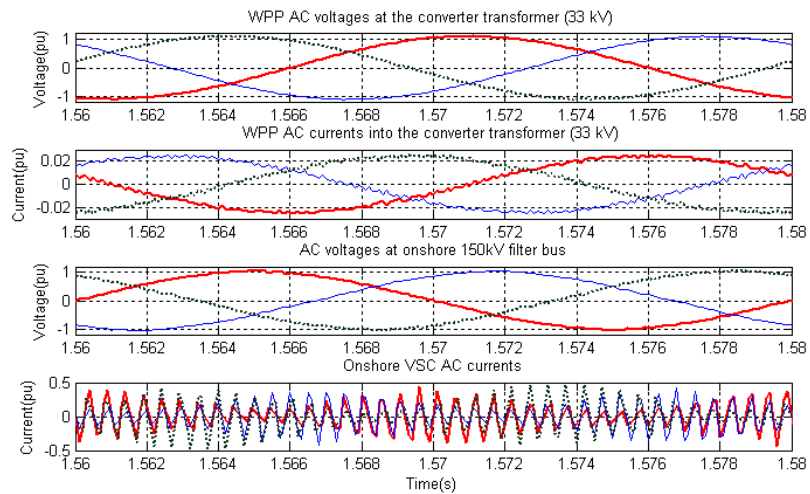

Fig. 7 Steady state operation at no load

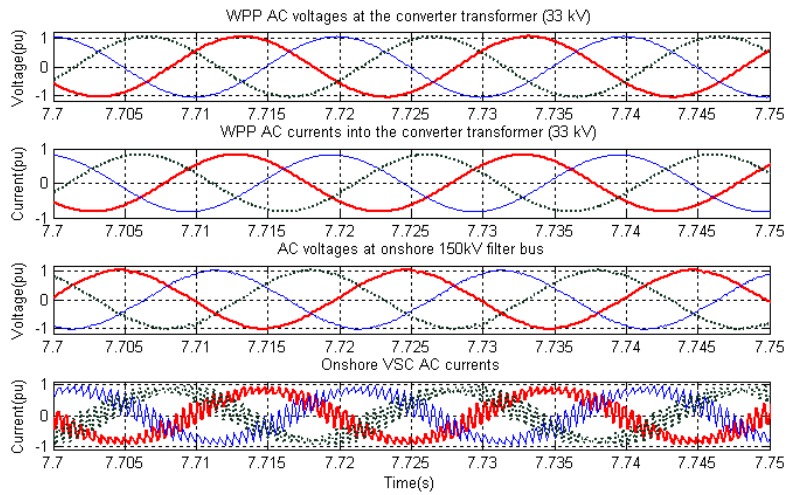

Fig. 8 Steady State operation at full 400MW WPP generation

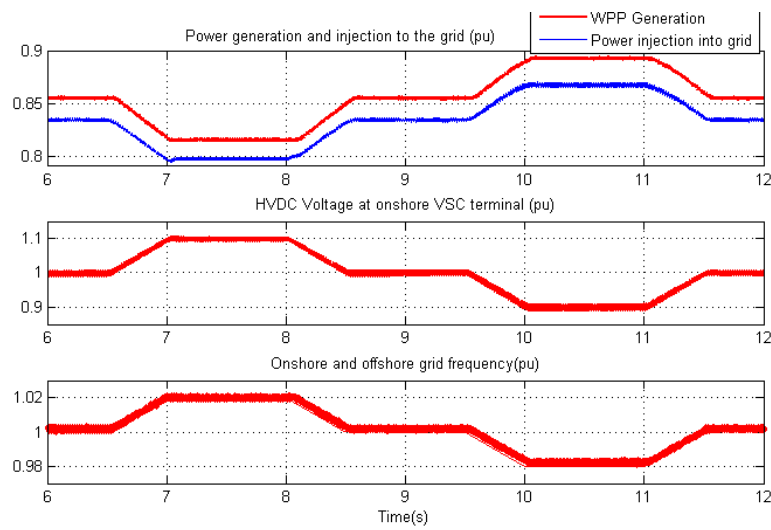

Fig. 9 WPP response to onshore grid frequency variation

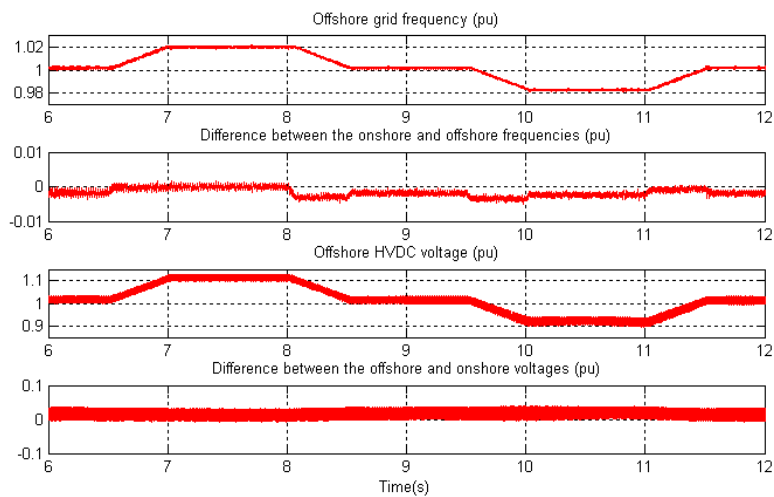

Fig. 10 Difference in voltages and frequencies measured onshore and offshore

In Fig 8, the onshore VSC AC currents have a fundamental component with superimposed switching ripples. The onshore current waveform shows the current entering the onshore VSC. Hence it appears to be in phase opposition implying that the power is flowing out of the VSC towards the grid.

III. PRIMARY RESERVE CONTROL AND FREQUENCY SUPPORT

Large WPP's are expected to participate in the frequency support activities through primary reserve control. A case has been simulated for this. In the simulation, the onshore grid frequency is first raised to 51 Hz and then decreased to 49 Hz and the response of the wind power plant is observed.

In this study, the HVDC voltage is used to relay the onshore grid frequency to the offshore [7]. Once the grid frequency state is known to the offshore WPP, the FCWTG can be controlled to provide the primary frequency response.

The control algorithm can be summarized into the following steps –

- i. Measure onshore grid frequency deviation from and modify HVDC reference voltage for the onshore VSC converter as follows,

$$V_{HVDC_ref}^{mod} = V_{HVDC_ref} \cdot \left[1 + \left(\frac{f_m - f_n}{f_n} \right) \cdot S_{fv} \right] \quad (2)$$

where, f_m and f_n are the measured and nominal frequencies respectively. S_{fv} is the frequency to voltage sensitivity setting of the onshore VSC controller.

In the present simulation, $S_{fv} = 5$ has been used to achieve 5% change in HVDC voltage reference per unit percentage change in onshore grid frequency. V_{HVDC_ref} is the original HVDC reference voltage at onshore terminal. Deadbands may be included if required.

- ii. y

$$\Delta V_{pu_HVDC_off} = \frac{V_{m_HVDC_off} - V_{cable} - V_{HVDC_ref}}{V_{cable} + V_{HVDC_ref}} \quad (3)$$

- iii. Modify the offshore grid frequency in proportion to the pu deviation in offshore HVDC voltage.

$$f_{off_ref} = f_{off_n} \cdot \left(1 + \Delta V_{pu_HVDC_off} \cdot S_{vf} \right) \quad (4)$$

where, S_{vf} is the voltage to frequency sensitivity setting of the offshore VSC controller.

If S_{vf} is set as the reciprocal of S_{fv} , then the onshore grid frequency can be emulated in the offshore grid.

- iv. The WTG controllers can then be controlled to provide frequency support to the grid in response to the frequency observed at their terminals. In the simulation, a WPP generation increases by 2.5% per unit percentage (i.e. 0.5 Hz) change in frequency.

Fig 9 shows the voltage, frequency and power curves for this simulation. At the instant of 7 sec, the onshore grid frequency is raised by 2% to 51 Hz. Correspondingly, the HVDC voltage rises to 1.1 pu (330kV) and the power generation falls to 326MW from the previous value of 342MW. When the onshore grid frequency is decreased to 49Hz (i.e. 0.98pu), the HVDC voltage falls to 276kV and the offshore generation increases to 357MW. Fig 10 shows the small difference between the onshore and offshore frequencies.

IV. DISCUSSION

A model of WPP with VSC-HVDC connection to the onshore grid has been developed and the different operating conditions have been simulated. Operational sequence of starting up the VSC-HVDC, and energizing the offshore grid, sequential synchronization and connection of a number of aggregated WTG followed by power generation ramping up to full power level and then ramping down to 0 generation levels have been demonstrated. The simulation gives an overview of the overall system and its operation.

If the HVDC voltage is permitted to vary, then VSC-HVDC can efficiently relay the onshore grid frequency to the offshore grid. In simulation study it was found that the frequency information was relayed within a period of 10 ms.

ACKNOWLEDGMENT

This research is a part of Vestas Power Program at Department of Energy Technology and Department of Energy Technology, Aalborg University. It is jointly supported by Vestas Wind Systems A/S and Aalborg University.

APPENDIX

TABLE 1 LIST OF PARAMETERS USED IN SIMULATION

Onshore Grid		
1 Base MVA	500	MVA
2 Base voltage (rms, line-line)	400	kV
3 Short Circuit Capacity	25	pu
4 Grid Impedance Angle	80	degree
Converter Transformers (Onshore)		
1 Size	500	MVA
2 Voltage Ratio (for onshore)	400/150	kV/kV
3 Voltage Ratio (for offshore)	150/33	kV/kV
4 Leakage Reactance	0.12	pu
5 Cu-loss	0.01	pu
6 Fe-loss	0.01	pu
Phase reactors		
1 Inductance	0.105	pu
2 resistance	2.E-04	pu
HVDC System		
1 Pole to pole DC voltage	300	kV DC
2 Power rating	400	MW
HVDC Cable		
1 Cable length	200	km
2 resistance	2.797	Ω
3 Inductance	22.31	mH
4 Shunt Capacitance (at ends)	28.15	μ F
DC capacitors (at VSC terminal)	35.5	μ F

REFERENCES

- [1] *Global wind report 2008*, Global Wind Energy Council (GWEC), Available: http://www.gwec.net/fileadmin/documents/Publications/Report_2008/Global_Wind_2008_Report.pdf
- [2] S. K. Chaudhary, R. Teodorescu and P. Rodriguez, "Wind Farm Grid Integration Using VSC Based HVDC Transmission - An Overview," *Energy 2030 Conference, 2008. ENERGY 2008. IEEE*, pp. 1-7, 2008.

- [3] J. Machowski, J. W. Bialek and J. R. Bumby, *Power System Dynamics : Stability and Control*, 2nd ed. Chichester, U.K.: Wiley, 2008, pp. 629.
- [4] K. Eriksson, C. Liljegren and K. Sobrink, "HVDC light experiences applicable for power transmission from offshore wind power parks," in *42nd AIAA Aerospace Sciences Meeting and Exhibit, Reno, Nevada*, 2004,
- [5] Grid connection of offshore wind farms - NordE.ON 1, Available at <http://Www.abb.com/hvdc>.
- [6] L. Xu, B. W. Williams and L. Yao, "Multi-terminal DC transmission systems for connecting large offshore wind farms," *Power and Energy Society General Meeting - Conversion and Delivery of Electrical Energy in the 21st Century, 2008 IEEE*, pp. 1-7, 2008.
- [7] S. Jensen and F. W. Fuchs. Load-frequency control of synchronous areas using a wind farm connected via HVDC-VSC. Presented at Presented at 2nd EPE Wind Energy Seminar, KTH, Stockholm, Sweden, 23-24 April 2009.