



Aalborg Universitet

AALBORG UNIVERSITY
DENMARK

Modelling and Simulation of VSC-HVDC Connection for Offshore Wind Power Plants

Chaudhary, Sanjay Kumar; Teodorescu, Remus; Rodriguez, Pedro; Kjær, Philip Carne; Christensen, P. W.

Published in:

Proceedings of the Danish PhD Seminar on Detailed Modelling and Validation of Electrical Components and Systems 2010

Publication date:
2010

Document Version
Publisher's PDF, also known as Version of record

[Link to publication from Aalborg University](#)

Citation for published version (APA):

Chaudhary, S. K., Teodorescu, R., Rodriguez, P., Kjær, P. C., & Christensen, P. W. (2010). Modelling and Simulation of VSC-HVDC Connection for Offshore Wind Power Plants. In *Proceedings of the Danish PhD Seminar on Detailed Modelling and Validation of Electrical Components and Systems 2010* (pp. 53-57). Energinet.dk.

General rights

Copyright and moral rights for the publications made accessible in the public portal are retained by the authors and/or other copyright owners and it is a condition of accessing publications that users recognise and abide by the legal requirements associated with these rights.

- ? Users may download and print one copy of any publication from the public portal for the purpose of private study or research.
- ? You may not further distribute the material or use it for any profit-making activity or commercial gain
- ? You may freely distribute the URL identifying the publication in the public portal ?

Take down policy

If you believe that this document breaches copyright please contact us at vbn@aub.aau.dk providing details, and we will remove access to the work immediately and investigate your claim.

Modelling and Simulation of VSC-HVDC Connection for Offshore Wind Power Plants

S. K. Chaudhary, R. Teodorescu, P. Rodriguez, P. C. Kjaer and P. W. Christensen

Abstract — Several large offshore wind power plants (WPP) are planned in the seas around Europe. VSC-HVDC is a suitable means of integrating such large and distant offshore WPP which need long submarine cable transmission to the onshore grid. Recent trend is to use large wind turbine generators with full scale converters to achieve an optimal operation over a wide speed range. The offshore grid then becomes very much different from the conventional power system grid, in the sense that it is connected to power electronic converters only. A model of the wind power plant with VSC-HVDC connection is developed in PSCAD for time-domain dynamic simulation. This paper presents the modelling and simulation of such a system. A single line to ground fault has been simulated and fault currents for the grounded and ungrounded offshore grid system is obtained through simulation and then compared.

Index Terms—Wind power plant, wind turbine generator, modelling, VSC-HVDC, full scale converters and Faults

I. INTRODUCTION

EMPHASIS on clean and green renewable energy sources amid rising environmental concerns has led to the rapid development of wind turbine generator (WTG) technology and large wind power plants (WPP). Recently the focus has shifted to the huge potential of offshore wind energy. A total of 1471 MW of offshore wind power generation, all in European seas, has been installed by the end of 2008, with 357 MW of offshore WPP was installed in the year 2008 [1]. As per the reference scenario of EWEA, by 2030, the offshore WPP is expected to contribute 120 GW out of 300 GW of installed wind power generation [2].

High voltage ac transmission is not suitable for long distance cable transmission [3]. VSC-HVDC provides feasible transmission link for connecting distant offshore WPP using polymer insulated submarine cables. Apart from that it has several technical advantages like fast, independent and reversible control of active flow and reactive power generation

This work was supported in part by Vestas Wind Systems A/S under the Vestas Power Program.

S. K. Chaudhary and R. Teodorescu are with the Department of Energy Technology, Aalborg University Denmark (e-mails: skc@iet.aau.dk and ret@iet.aau.dk).

P. Rodriguez is with the Technical University of Catalonia, Spain. He is a visiting professor at Aalborg University, Denmark (e-mail: pro@iet.aau.dk).

P.C. Kjaer and P. W. Christensen are with the Vestas Wind Energy Systems A/S, Denmark (e-mails: pck@vestas.com and pewch@vestas.com).

Paper submitted to the PhD Seminar on Detailed Modelling and Validation of Electrical Components and Systems 2010 in Fredericia, Denmark, February 8th, 2010

at both ends. Its controllability facilitates the WPP developers to meet the grid code requirements with regard to fault ride through, reactive power control and voltage support [4].

The WPP is assumed to be comprising of wind turbine generators (WTG) equipped with full scale converters (FSC) [5]. The full scale converter decouples the machine frequency from the offshore grid frequency thereby enabling the variable speed operation in the whole speed range of operation.

This paper describes the layout and modelling of wind turbine with full-scale converters and the offshore grid for a large WPP with VSC-HVDC connection to the onshore grid and simulation studies for different types of faults in the offshore grid. Section II describes the WPP layout and the overall system model. Section III presents the modelling details of the wind turbines, VSC-HVDC and the overall system. Simulation results of faults in the offshore grid and their impact upon the system is presented in IV. Finally it is concluded in section V.

II. SYSTEM DIAGRAM AND MODEL DEVELOPMENT

Fig 1 shows the system being studied. A simple Thevenin's equivalent is used to represent the onshore grid, while the VSC-HVDC has been modelled in detail with switched converters and their controller, converter transformers, phase reactors, filters and DC capacitors, HVDC cable, DC line reactors. Offshore converter transformer is connected to the two 150 kV offshore buses through a pair 150 kV cables. Each of the 150 kV bus is then connected to 2 33 kV bus through a 3 winding (150/33/33 kV) transformer [6]. The 33 kV bus serves as the collector bus where the cables connecting the wind turbines are terminated. In the present model, 100 MW aggregated models of the wind turbine generators have been considered. Therefore, only one cable is shown connected to a single wind turbine generator.

In the present system model, the individual wind turbine generators have not been modelled; instead single aggregated WTG models have been connected through the scaled LCL filter and the scaled transformer to the 33 kV collector bus through cables.

When identical components are present on the offshore and onshore, suffixes '1' and '2' are used respectively to indicate offshore and onshore components.

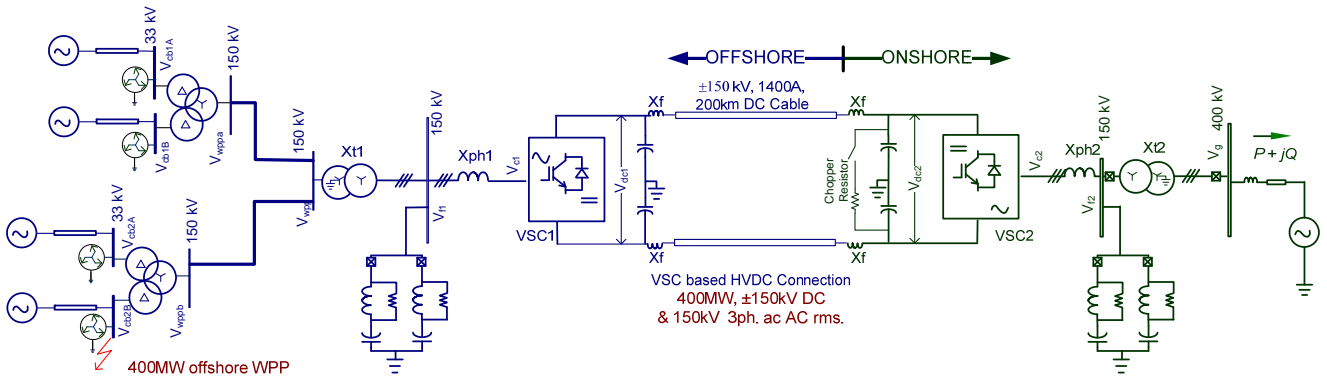

Fig. 1 Block diagram of the system layout

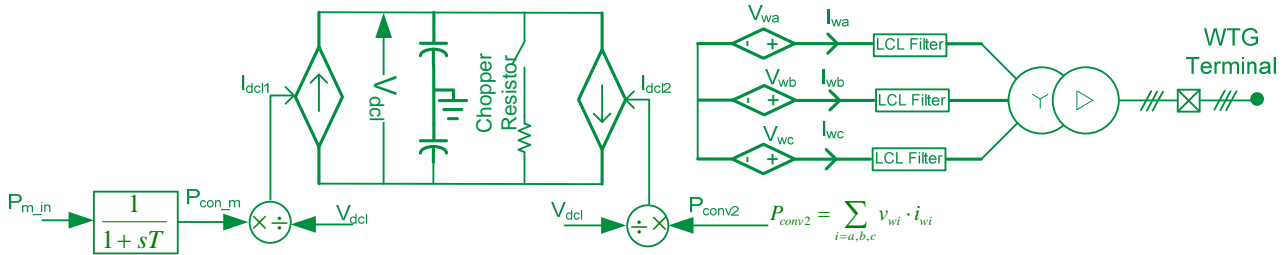

Fig. 2 Simplified model of a wind turbine generator with full scale converter (WTG-FSC)

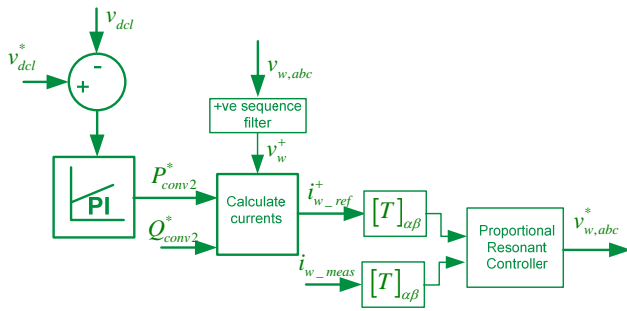

Fig. 3 Reference voltage generation for the grid side converter in the WTG-FSC

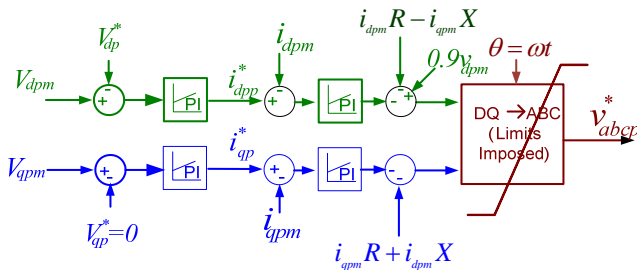

Fig. 4 Offshore VSC controller (positive sequence)

A. WTG with FSC model

Every WTG is assumed to be equipped with its own FSC. In this simulation study the wind model, aerodynamics, gear system, the synchronous generator and the generator side converter is collectively modelled as a first order transfer function with a 20ms time constant. Mechanical power is input as a reference input power and then after the transfer function it appears as an equivalent dc current source

connected to the dc link of the full scale converter as shown in Fig. 2

DC link capacitors and the chopper resistors are included in the WTG-FSC model. Average value model is used for the grid side converter on the basis of ideal controller behaviour and no power loss in the converter. Such a model neglects the converter time delay as and the losses, which may be of the order of 1-2%. However these simplifications are acceptable when the overall power system behaviour is of interest.

The role of the grid side converter in the WTG-FSC is to maintain the DC-link voltage and supply/absorb reactive power if ordered. From the deviations in the DC-link voltage, the amount of power (P_{conv2}^*) to be evacuated is determined. Then the converter controller estimates the required positive sequence current flow to the grid, which is later converted to the desired voltage levels using the proportional resonant controllers in the stationary reference frame (Fig. 3). The reactive power output of the converter can be specified externally, as it is independent of the active power balance requirements. In the present simulation, the reactive power reference to WTG-FSC is set to 0. The WTG FSC is interfaced to the 33kV cables in the collector grid through LCL filters and a step-up transformer.

B. Off-shore VSC and its controller

The offshore VSC controller (VSCC1) maintains the offshore grid voltage and frequency. Voltage control is achieved by applying the desired reference voltage along the d-axis while setting the q-axis voltage to 0. Synchronously rotating reference frame is selected such that the voltage phasor is aligned with the d-axis. Current references are generated from these AC voltage controllers in the outer loop. The inner loops produce the reference voltages which are

augmented by the feed-forward of the voltage at the filter bus and compensation for the drop in the phase reactor [7]. Pulse width modulation (PWM) signals are generated using sine-triangle comparison as shown in Fig. 4.

C. Onshore VSC Controller

The onshore VSC controller (VSCC2) regulates the HVDC voltage and the reactive power (or AC terminal voltage) exchanged with the onshore grid as shown in Fig 5. The HVDC voltage regulation loop sets the d-axis current reference while the reactive power is controlled by setting the q-axis current reference. These are controlled by the inner current loop controls as described in the previous section [7].

The reactive power control loop may be switched in the voltage (at PCC) control mode. Then the sensitivity of the PCC voltage with respect to the reactive power injection is used to determine the q-axis current reference.

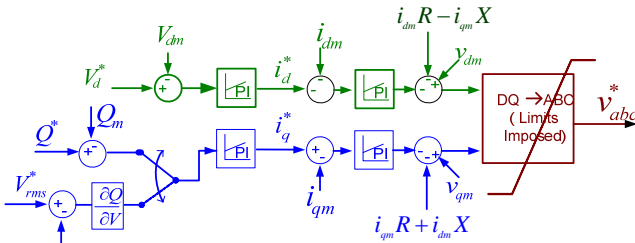
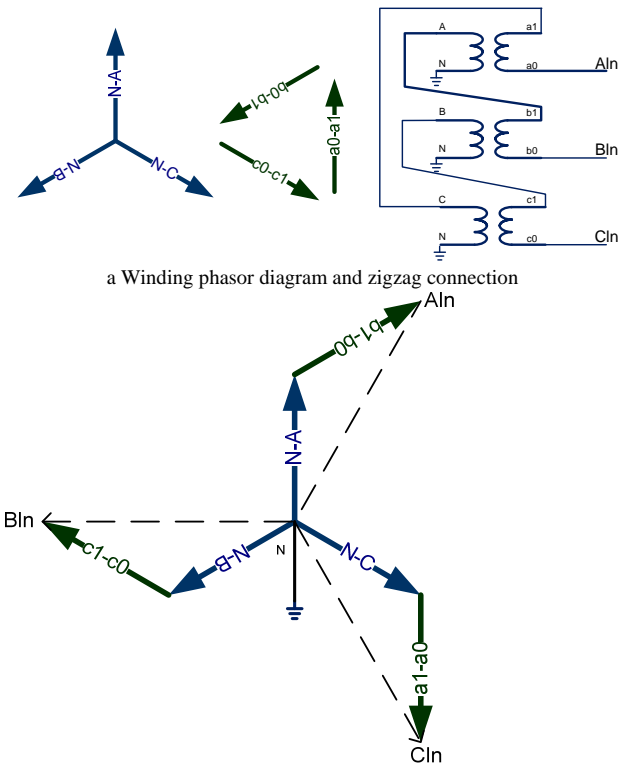

Fig. 5 Onshore VSC controller



b Resultant terminal voltage phasors

Fig. 6 Phasor Diagram and winding connection of a zigzag grounding transformer

D. Grounding Transformer

Four zigzag transformers, as shown in Fig. 6, are used to ground the 33kV collector busses in the offshore WPP buses. The primary windings are connected in star and the secondary windings are connected in the auto-transformer connection, with the phase connections as shown in the phasor diagram. The resultant configuration provides 0-impedance path for the 0-sequence components while it offers high impedance to the positive and negative sequence components of the voltage.

An ungrounded system is simulated by disconnecting this transformer.

III. SIMULATION OF THE WPP, VSC-HVDC SYSTEM

In the beginning the whole of the WPP, VSC-HVDC system is assumed de-energized and in steady state at ground potential. As soon as the onshore grid side breaker is connected and the VSC-HVDC gets charged to approximately 150kV by the rectifier action of the anti-parallel diodes in the converter. Then the onshore grid side VSC is de-blocked and the gate pulses are applied. The VSC-HVDC thus, gets charged to the operating voltage of ± 150 kV. Following this the offshore VSC is de-blocked and the offshore grid gets energized.

Regarding the connection of the wind turbine generators, they may have the dc-link in the full scale converters energized by their auxiliaries or it may be energized from the offshore grid. In the present simulation, it is assumed that the WTG-FSC dc links are energized by the WTG auxiliary supply. Hence, the WTG-FSC are ready for synchronization and connection to the offshore grid. After that the WTG generation can be allowed by setting the input mechanical power references. Then the power is ramped up to the maximum power levels. Though, the WTG-FSC system can generate reactive power as well, the reactive power reference for the WTG-FSC is set to 0. Fig 7 presents power flow vs. time curve for this sequence of operation. Due to the cables in the collector system and the 150kV connectors, the WPP supplies reactive power (Mvar) to the VSC-HVDC at low active power generation, even though WTG's are not generating any var. As the generation increases, the var consumption within the offshore grid increases. In this case, VSC-HVDC is controlled such that it does not inject any var to the onshore grid.

Afterwards an asymmetrical fault in the offshore grid is simulated for a period of 150ms for the two cases with grounded collector bus system and the ungrounded collector system. The fault currents in these two cases are then compared. A single line to ground fault between phase A and the ground has been simulated on a 33kV collector bus, with a fault impedance of 0.0025 Ω .

A. Single Line to ground (L-G) fault in an ungrounded system

In an ungrounded system, the faulted phase A voltage goes to zero, while the other phases observe over-voltage as shown in Fig. 8. There is no fault current due to lack of grounding. Current and voltage waveforms as well as the power flows do not get affected as shown in Fig. 9.

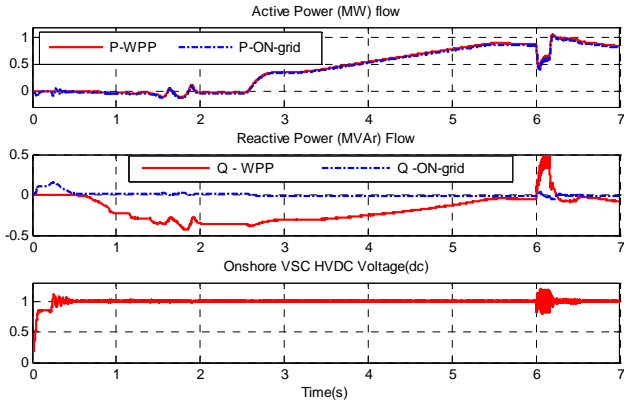

Fig. 7 (i) Active power flow from WPP to VSC-HVDC (P-WPP) and from VSC-HVDC to the onshore grid (P-ON-grid) (ii) Reactive power flow to the offshore grid (Q-WPP) and to the onshore grid (Q-ON-grid) (iii) VSC-HVDC operating voltage in p.u.

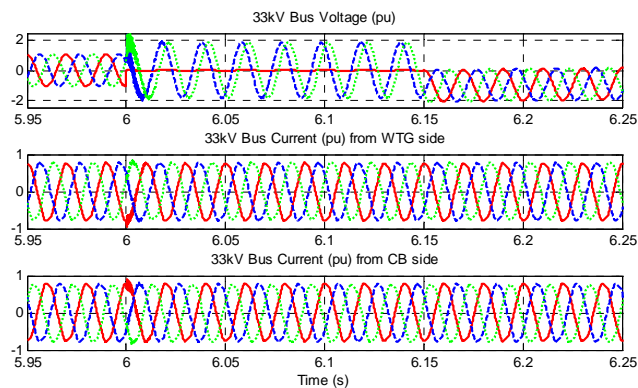

Fig. 8 Voltage at the 33kV faulted bus, and currents observed on the both sides of the L-G fault in an ungrounded offshore grid

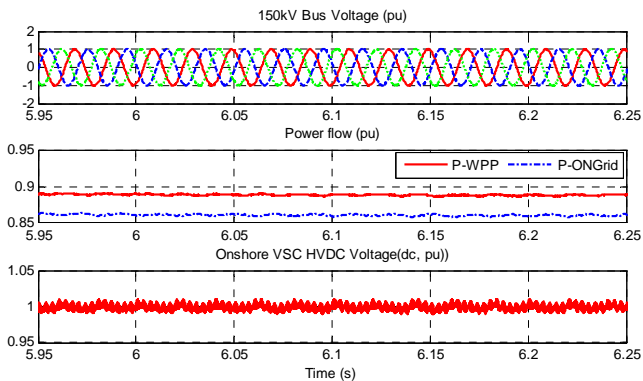

Fig. 9 150kV bus voltage waveform, HVDC power flows and the HVDC voltage during the L-G fault in the ungrounded system.

B. Single Line to ground (L-G) fault in a grounded system

Zigzag connected grounding transformers are connected to the 33kV collector buses to provide the path for the grounding current and thus grounding the offshore grid. By virtue of the transformer connection, the currents in all the three phases are equal and in the same phase. Thus a low impedance path is provided for the 0-sequence currents.

Fig 10 shows the voltage and current waveforms in the 33kV grid at the point of the fault. Power flow oscillations and consequently 100Hz oscillations appear in the HVDC DC

voltage as shown in Fig 11. When the voltage waveforms are decomposed into sequence components, the presence of negative sequence voltage is observed in the voltage waveforms (Fig. 11).

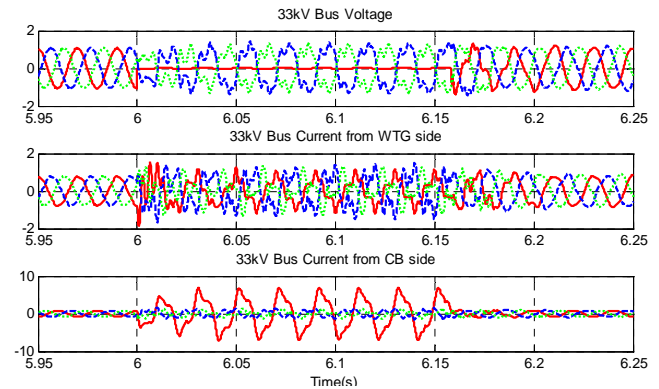

Fig. 10 Voltage at the 33kV faulted bus, and currents observed on the both sides of the L-G fault in a grounded offshore grid

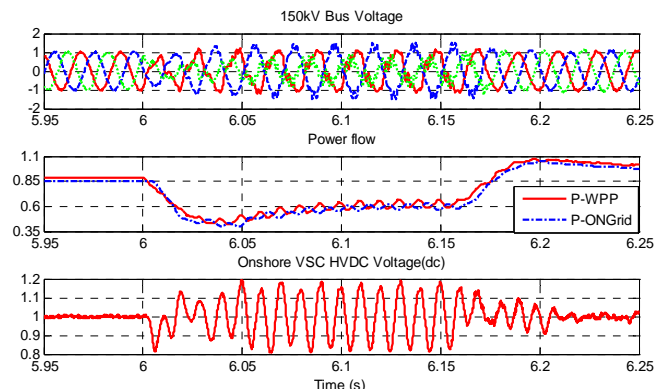

Fig. 11 150kV bus voltage waveform, HVDC power flows and the HVDC voltage during the L-G fault in the ungrounded system.

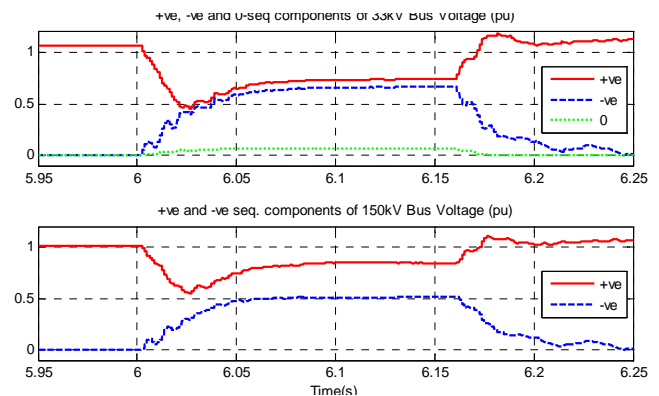

Fig. 12 Sequence components of the voltages in the 33kV and 150 kV grid during the L-G fault.

The response of the two circuits, the healthy one which does not have any fault on the collector bus and the faulted one with a single line to ground fault close to the collector bus is compared in Fig 13. Power flow from the healthy circuit is higher than the other. The fault is drawing the reactive of the order of over 2pu from the collector bus. Curves of grounding transformer neutral currents indicate that all the fault current flows through the grounding transformer in the faulted circuit

(Fig 10 and Fig 13).

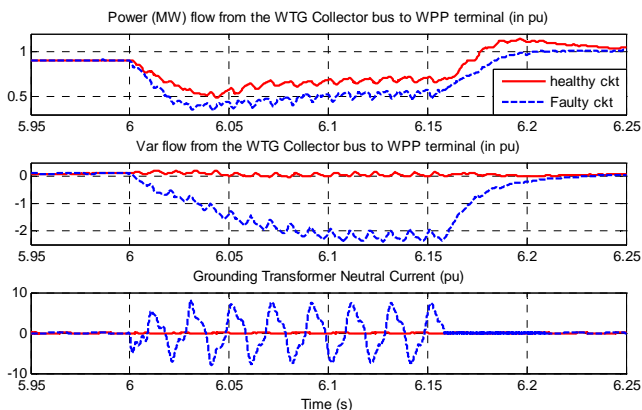

Fig. 13 Active and reactive power flows from the WTG's with healthy collector bus and the WTG with a fault on the collector bus.

IV. DISCUSSION

The simulation results show that the simulation model is robust enough to investigate the normal operating modes as well as faults in the offshore grid. Onshore grid has not been modelled in detail, but if need be the model can be plugged into a more detailed grid model and the impact of grid disturbances can be studied.

Simulation of the asymmetrical faults demonstrates the importance of system grounding in the offshore grid network. Even though an ungrounded system presents an advantage as a single line-to-ground fault does not necessitate the service interruption, the situation is dangerous as the healthy phases can attain unsafe voltage levels. Persistent higher voltage stress may lead to a second fault which has to be isolated.

Simulation of the grounded system gives an idea of the fault current levels in the offshore grid and this information will be useful in the design of the protection system for the offshore grid.

REFERENCES

- [1] "Seas of Change: Offshore Wind Energy," The European Wind Energy Association (EWEA), 2009.
- [2] "Pure power wind energy scenarios upto 2030," The European Wind Energy Association (EWEA), Available: http://www.ewea.org/fileadmin/ewea_documents/documents/00_POLICY_document/PP.pdf
- [3] T. Ackermann, *Wind Power in Power Systems; Wind Power in Power Systems.*, John Wiley, 2005.
- [4] S. K. Chaudhary, R. Teodorescu and P. Rodriguez, "Wind Farm Grid Integration Using VSC Based HVDC Transmission - An Overview," *Energy 2030 Conference, 2008. ENERGY 2008. IEEE*, pp. 1-7, 2008.
- [5] J. Conroy and R. Watson, "Aggregate modelling of wind farms containing full-converter wind turbine generators with permanent magnet synchronous machines: transient stability

studies," *Renewable Power Generation, IET*, vol. 3, pp. 39-52, 2009.

[6] R. van de Sandt, J. Lowen, J. Paetzold and I. Erlich, "Neutral earthing in off-shore wind farm grids," *PowerTech, 2009 IEEE Bucharest*, pp. 1-8, 2009.

[7] L. Xu, B. W. Williams and L. Yao, "Multi-terminal DC transmission systems for connecting large offshore wind farms," *Power and Energy Society General Meeting - Conversion and Delivery of Electrical Energy in the 21st Century, 2008 IEEE*, pp. 1-7, 2008.